

TS3USB221E High-Speed USB 2.0 (480Mbps) 1:2 Multiplexer – Demultiplexer Switch With Single Enable and IEC Level 3 ESD Protection

1 Features

- V_{CC} operation of 2.3V to 3.6V
- Switch I/Os accept signals up to 5.5V
- 1.8V compatible control-pin inputs
- Low-power mode when \overline{OE} is disabled (1 μ A)
- $r_{ON} = 6\Omega$ maximum
- $\Delta r_{ON} = 0.2\Omega$ typical
- $C_{IO(ON)} = 7\text{pf}$ maximum
- Low power consumption (30 μ A maximum)
- ESD performance tested:
 - 7000V human body model per JEDEC JS-001
 - 1000V charged-device model per JEDEC JS-002
- ESD performance I/O port to GND:
 - 12kV human body model (JEDEC JS-001)
 - $\pm 7\text{kV}$ contact discharge (IEC 61000-4-2)
- High bandwidth (1GHz typical)

2 Applications

- Routes signals for USB 1.0, 1.1, and 2.0
- Mobile phones
- Digital cameras
- Notebooks
- USB I/O expansion
- MHL 1.0

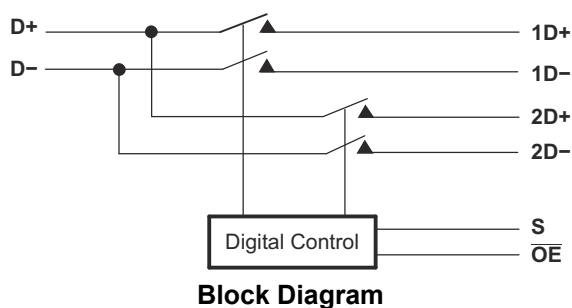

3 Description

The TS3USB221E is a high-bandwidth switch specially designed for the switching of high-speed USB 2.0 signals in handset and consumer applications, such as cell phones, digital cameras, and notebooks with hubs or controllers with limited USB I/Os. The wide bandwidth (1GHz) of this switch allows signals to pass with minimum edge and phase distortion. The device multiplexes differential outputs from a USB host device to one of two corresponding outputs. The switch is bidirectional and offers little or no attenuation of the high-speed signals at the outputs. The TS3USB221E is designed for low bit-to-bit skew and high channel-to-channel noise isolation, and is compatible with various standards, such as high-speed USB 2.0 (480Mbps).

The TS3USB221E integrates ESD protection cells on all pins, is available in a SON package (3mm \times 3mm) as well as in a tiny μ QFN package (2mm \times 1.5mm) and is characterized over the free-air temperature range from -40°C to 85°C .

Package Information

PART NUMBER	PACKAGE ⁽¹⁾	PACKAGE SIZE ⁽²⁾
TS3USB221E	DRC (VSON, 10)	3mm \times 3mm
	RSE (UQFN, 10)	2mm \times 1.5mm

- (1) For all available packages, see the orderable addendum at the end of the data sheet.
- (2) The package size (length \times width) is a nominal value and includes pins, where applicable.

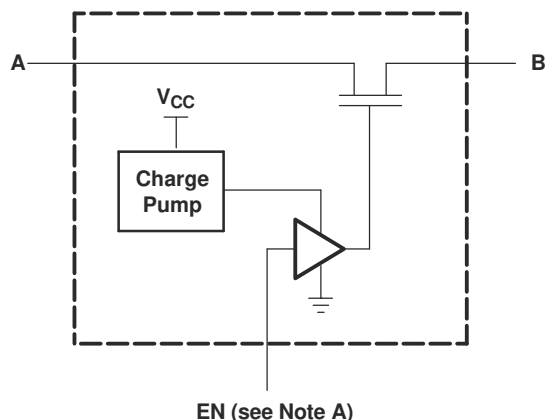

- A. EN is the internal enable signal applied to the switch.

Simplified Schematic, Each FET Switch (SW)



Table of Contents

1 Features	1	6.2 Functional Block Diagram.....	12
2 Applications	1	6.3 Feature Description.....	12
3 Description	1	6.4 Device Functional Modes.....	12
4 Pin Configuration and Functions	3	7 Application and Implementation	13
5 Specifications	4	7.1 Application Information.....	13
5.1 Absolute Maximum Ratings.....	4	7.2 Typical Application.....	13
5.2 ESD Ratings.....	4	7.3 Power Supply Recommendations.....	14
5.3 Recommended Operating Conditions.....	4	7.4 Layout.....	14
5.4 Thermal Information.....	5	8 Device and Documentation Support	16
5.5 Electrical Characteristics.....	5	8.1 Documentation Support.....	16
5.6 Dynamic Electrical Characteristics, $V_{CC} = 3.3\text{ V}$ $\pm 10\%$	6	8.2 Receiving Notification of Documentation Updates....	16
5.7 Dynamic Electrical Characteristics, $V_{CC} = 2.5\text{ V}$ $\pm 10\%$	6	8.3 Support Resources.....	16
5.8 Switching Characteristics, $V_{CC} = 3.3\text{ V} \pm 10\%$	6	8.4 Trademarks.....	16
5.9 Switching Characteristics, $V_{CC} = 2.5\text{ V} \pm 10\%$	6	8.5 Electrostatic Discharge Caution.....	16
5.10 Typical Characteristics.....	7	8.6 Glossary.....	16
6 Detailed Description	12	9 Revision History	16
6.1 Overview.....	12	10 Mechanical, Packaging, and Orderable Information	17

4 Pin Configuration and Functions

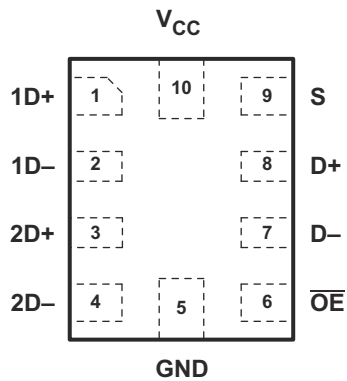

Figure 4-1. RSE Package, 10-Pin UQFN (Top View)

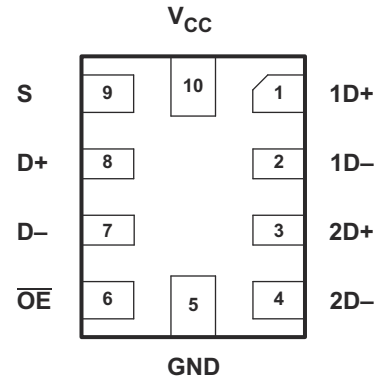

Figure 4-2. RSE Package, 10-Pin UQFN (Bottom View)

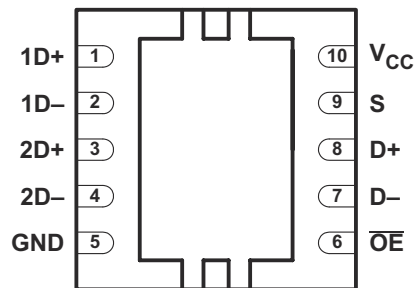

Figure 4-3. DRC Package, 10-Pin VSON (Top View)

Table 4-1. Pin Functions

PIN		TYPE ⁽¹⁾	DESCRIPTION
NAME	NO.		
1D+	1	I/O	USB port 1
1D-	2	I/O	
2D+	3	I/O	
2D-	4	I/O	
GND	5	—	Ground
$\overline{\text{OE}}$	6	I	Bus-switch enable
D-	7	I/O	Common USB port
D+	8	I/O	
S	9	I	Select input
V _{CC}	10	—	Supply voltage

(1) I = input, O = output

5 Specifications

5.1 Absolute Maximum Ratings

over operating free-air temperature range (unless otherwise noted)⁽¹⁾

		MIN	MAX	UNIT
V _{CC}	Supply voltage	-0.5	4.6	V
V _{IN}	Control input voltage ^{(2) (3) (4)}	-0.5	7	V
V _{I/O}	Switch I/O voltage ^{(2) (3) (4)}	-0.5	7	V
I _{IK}	Control input clamp current	V _{IN} < 0	-50	mA
I _{I/OK}	I/O port clamp current	V _{I/O} < 0	-50	mA
I _{I/O}	ON-state switch current ⁽⁵⁾		±120	mA
	Continuous current through V _{CC} or GND		±100	mA
θ _{JA}	Package thermal impedance ⁽⁶⁾	DRC package	48.7	°C/W
		RSE package	243	
T _{stg}	Storage temperature	-65	150	°C

- (1) Stresses beyond those listed under *Absolute Maximum Ratings* may cause permanent damage to the device. These are stress ratings only, and functional operation of the device at these or any other conditions beyond those indicated under *Recommended Operating Conditions* is not implied. Exposure to absolute-maximum-rated conditions for extended periods may affect device reliability.
- (2) All voltages are with respect to ground, unless otherwise specified.
- (3) The input and output voltage ratings may be exceeded if the input and output clamp-current ratings are observed.
- (4) V_I and V_O are used to denote specific conditions for V_{I/O}.
- (5) I_I and I_O are used to denote specific conditions for I_{I/O}.
- (6) The package thermal impedance is calculated in accordance with JESD 51-7.

5.2 ESD Ratings

		VALUE	UNIT
V _(ESD)	Electrostatic discharge	Human-body model (HBM), per ANSI/ESDA/JEDEC JS-001 ⁽¹⁾	I/O pins to GND ±12000
			Pins GND, \overline{OE} , S and V _{CC} ±7000
		Contact discharge (IEC 61000-4-2)	I/O pins to GND ±7000
		Charged-device model (CDM), per JEDEC specification JESD-002 ⁽²⁾	±1000

- (1) JEDEC document JEP155 states that 500-V HBM allows safe manufacturing with a standard ESD control process.
- (2) JEDEC document JEP157 states that 250-V CDM allows safe manufacturing with a standard ESD control process.

5.3 Recommended Operating Conditions

See ⁽¹⁾.

		MIN	MAX	UNIT
V _{CC}	Supply voltage	2.3	3.6	V
V _{IH}	High-level control input voltages	V _{CC} = 2.3 V to 2.7 V	0.46 × V _{CC}	V
		V _{CC} = 2.7 V to 3.6 V	0.46 × V _{CC}	
V _{IL}	Low-level control input voltage	V _{CC} = 2.3 V to 2.7 V	0.25 × V _{CC}	V
		V _{CC} = 2.7 V to 3.6 V	0.25 × V _{CC}	
V _{I/O}	Data input/output voltage ⁽²⁾	0	5.5	V
T _A	Operating free-air temperature	-40	85	°C

- (1) All unused control inputs of the device must be held at V_{CC} or GND to ensure proper device operation. Refer to the [Implications of Slow or Floating CMOS Inputs](#) application note.
- (2) The I/O pins are 5.5V tolerant and functional for the entire range. However, for V_{I/O} > 3.6V, channel R_{ON} will be high. Use 3.3V power supply for best results.

5.4 Thermal Information

THERMAL METRIC ⁽¹⁾		TS3USB221E		UNIT
		DRC (VSON)	RSE (UQFN)	
		10 PINS	10 PINS	
R _{θJA}	Junction-to-ambient thermal resistance	57.7	204.8	°C/W
R _{θJC(top)}	Junction-to-case (top) thermal resistance	87.7	118.1	
R _{θJB}	Junction-to-board thermal resistance	32.6	121.5	
ψ _{JT}	Junction-to-top characterization parameter	8.2	13.9	
ψ _{JB}	Junction-to-board characterization parameter	32.8	121.2	
R _{θJC(bot)}	Junction-to-case (bottom) thermal resistance	18.5	N/A	

(1) For more information about traditional and new thermal metrics, see the [IC Package Thermal Metrics](#) application note.

5.5 Electrical Characteristics

over operating free-air temperature range (unless otherwise noted)⁽¹⁾

PARAMETER	TEST CONDITIONS		MIN	TYP ⁽²⁾	MAX	UNIT	
V _{IK}	V _{CC} = 3.6 V, 2.7 V,	I _I = -18 mA	-1.8			V	
I _{IN}	Control inputs	V _{CC} = 3.6 V, 2.7 V, 0 V, V _{IN} = 0 V to 3.6 V			±1	μA	
I _{OZ} ⁽³⁾	V _{CC} = 3.6 V, 2.7 V, V _O = 0 V to 5.25 V, V _I = 0 V,	V _{IN} = V _{CC} or GND, Switch OFF			±1	μA	
I _{OFF}	V _{CC} = 0 V	V _{I/O} = 0 V to 5.25 V			±2	μA	
		V _{I/O} = 0 V to 3.6 V			±2		
		V _{I/O} = 0 V to 2.7 V			±1		
I _{CC}	V _{CC} = 3.6 V, 2.7 V, V _{IN} = V _{CC} or GND,	I _{I/O} = 0 V, Switch ON or OFF			30	μA	
I _{CC} (low power mode)	V _{CC} = 3.6 V, 2.7 V, V _{IN} = V _{CC} or GND	Switch disabled (OE in high state)			1	μA	
I _{CC} ⁽⁴⁾	Control inputs	One input at 1.8 V, Other inputs at V _{CC} or GND	V _{CC} = 3.6 V		20	μA	
			V _{CC} = 2.7 V		0.5		
C _{in}	Control inputs	V _{CC} = 3.3 V, 2.5 V, V _{IN} = 3.3 V or 0 V		1.5	2.5	pF	
C _{io(OFF)}		V _{CC} = 3.3 V, 2.5 V, V _{I/O} = 3.3 V or 0 V, Switch OFF		3.5	5	pF	
C _{io(ON)}		V _{CC} = 3.3 V, 2.5 V, V _{I/O} = 3.3 V or 0 V, Switch ON		6	7.5	pF	
r _{ON} ⁽⁵⁾		V _{CC} = 3 V, 2.3 V	V _I = 0 V, I _O = 30 mA		3	6	Ω
			V _I = 2.4 V, I _O = -15 mA		3.4	6	
Δr _{ON}		V _{CC} = 3 V, 2.3 V	V _I = 0 V, I _O = 30 mA		0.2		Ω
			V _I = 1.7, I _O = -15 mA		0.2		
r _{ON(flat)}		V _{CC} = 3 V, 2.3 V	V _I = 0 V, I _O = 30 mA		1		Ω
			V _I = 1.7, I _O = -15 mA		1		

(1) V_{IN} and I_{IN} refer to control inputs. V_I, V_O, I_I, and I_O refer to data pins.

(2) All typical values are at V_{CC} = 3.3 V (unless otherwise noted), T_A = 25°C.

(3) For I/O ports, the parameter I_{OZ} includes the input leakage current.

(4) This is the increase in supply current for each input that is at the specified TTL voltage level, rather than V_{CC} or GND.

(5) Measured by the voltage drop between the A and B terminals at the indicated current through the switch. ON-state resistance is determined by the lower of the voltages of the two (A or B) terminals.

5.6 Dynamic Electrical Characteristics, $V_{CC} = 3.3\text{ V} \pm 10\%$

 over operating range, $T_A = -40^\circ\text{C}$ to 85°C , $V_{CC} = 3.3\text{ V} \pm 10\%$, $GND = 0\text{ V}$

PARAMETER		TEST CONDITIONS	TYP ⁽¹⁾	UNIT
X_{TALK}	Crosstalk	$R_L = 50$, $f = 250\text{ MHz}$	-40	dB
O_{IRR}	OFF isolation	$R_L = 50$, $f = 250\text{ MHz}$	-40	dB
BW	Bandwidth (-3 dB)	$R_L = 50$	1	GHz

- (1) For Maximum or Minimum conditions, use the appropriate value specified under [Electrical Characteristics](#) for the applicable device type.

5.7 Dynamic Electrical Characteristics, $V_{CC} = 2.5\text{ V} \pm 10\%$

 over operating range, $T_A = -40^\circ\text{C}$ to 85°C , $V_{CC} = 2.5\text{ V} \pm 10\%$, $GND = 0\text{ V}$

PARAMETER		TEST CONDITIONS	TYP ⁽¹⁾	UNIT
X_{TALK}	Crosstalk	$R_L = 50$, $f = 250\text{ MHz}$	-39	dB
O_{IRR}	OFF isolation	$R_L = 50$, $f = 250\text{ MHz}$	-40	dB
BW	Bandwidth (3 dB)	$R_L = 50$	1	GHz

- (1) For Maximum or Minimum conditions, use the appropriate value specified under [Electrical Characteristics](#) for the applicable device type.

5.8 Switching Characteristics, $V_{CC} = 3.3\text{ V} \pm 10\%$

 over operating range, $T_A = -40^\circ\text{C}$ to 85°C , $V_{CC} = 3.3\text{ V} \pm 10\%$, $GND = 0\text{ V}$

PARAMETER		MIN	TYP ⁽¹⁾	MAX	UNIT
t_{pd}	Propagation delay ^{(2) (3)}		0.25		ns
t_{ON}	Line enable time	S to D, nD		30	ns
		\overline{OE} to D, nD		17	
t_{OFF}	Line disable time	S to D, nD		12	ns
		\overline{OE} to D, nD		10	
$t_{SK(O)}$	Output skew between center port to any other port ⁽²⁾		0.1	0.2	ns
$t_{SK(P)}$	Skew between opposite transitions of the same output ($t_{PHL} - t_{PLH}$) ⁽²⁾		0.1	0.2	ns

- (1) For Maximum or Minimum conditions, use the appropriate value specified under [Electrical Characteristics](#) for the applicable device type.
- (2) Specified by design
- (3) The bus switch contributes no propagation delay other than the RC delay of the on resistance of the switch and the load capacitance. The time constant for the switch alone is of the order of 0.25 ns for 10-pF load. Because this time constant is much smaller than the rise/fall times of typical driving signals, it adds very little propagation delay to the system. Propagation delay of the bus switch, when used in a system, is determined by the driving circuit on the driving side of the switch and its interactions with the load on the driven side.

5.9 Switching Characteristics, $V_{CC} = 2.5\text{ V} \pm 10\%$

 over operating range, $T_A = -40^\circ\text{C}$ to 85°C , $V_{CC} = 2.5\text{ V} \pm 10\%$, $GND = 0\text{ V}$

PARAMETER		MIN	TYP ⁽¹⁾	MAX	UNIT
t_{pd}	Propagation delay ^{(2) (3)}		0.25		ns
t_{ON}	Line enable time	S to D, nD		50	ns
		\overline{OE} to D, nD		32	
t_{OFF}	Line disable time	S to D, nD		23	ns
		\overline{OE} to D, nD		12	
$t_{SK(O)}$	Output skew between center port to any other port ⁽²⁾		0.1	0.2	ns
$t_{SK(P)}$	Skew between opposite transitions of the same output ($t_{PHL} - t_{PLH}$) ⁽²⁾		0.1	0.2	ns

- (1) For Maximum or Minimum conditions, use the appropriate value specified under [Electrical Characteristics](#) for the applicable device type.
- (2) Specified by design

- (3) The bus switch contributes no propagation delay other than the RC delay of the on resistance of the switch and the load capacitance. The time constant for the switch alone is of the order of 0.25 ns for 10-pF load. This time constant is much smaller than the rise/fall times of typical driving signals, therefore the time adds very little propagation delay to the system. Propagation delay of the bus switch, when used in a system, is determined by the driving circuit on the driving side of the switch and its interactions with the load on the driven side.

5.10 Typical Characteristics

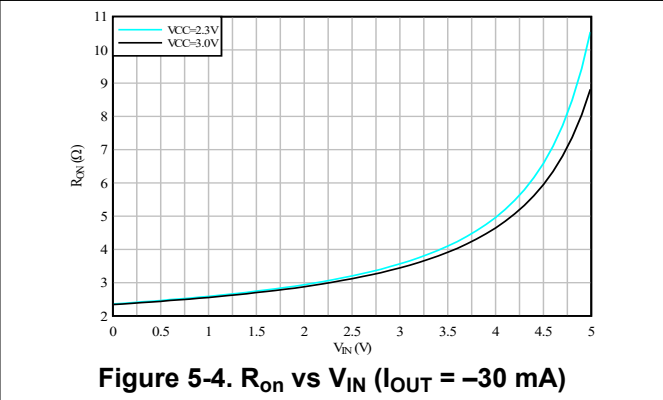
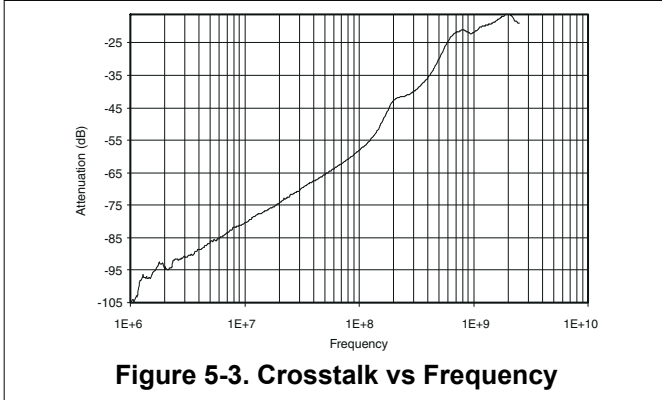
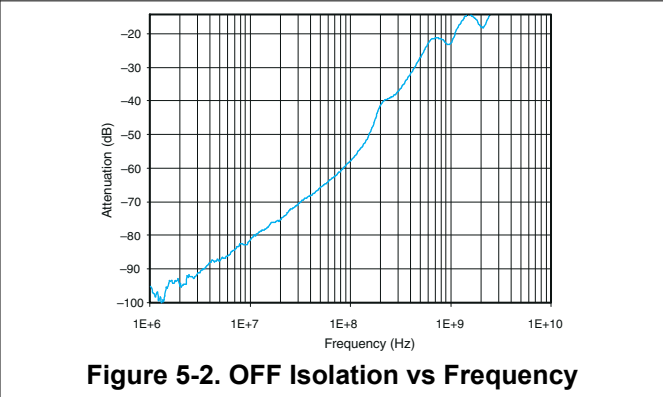
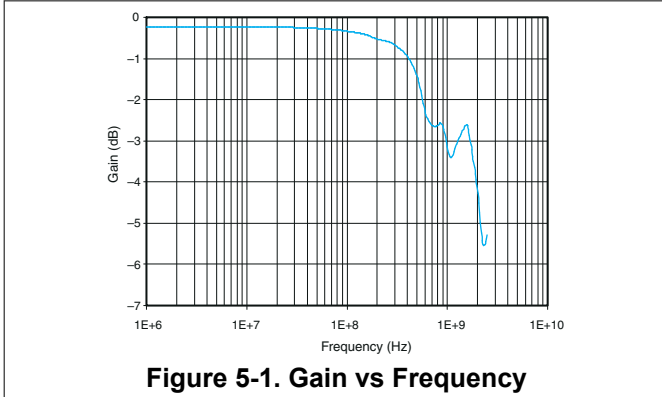

Parameter Measurement Information

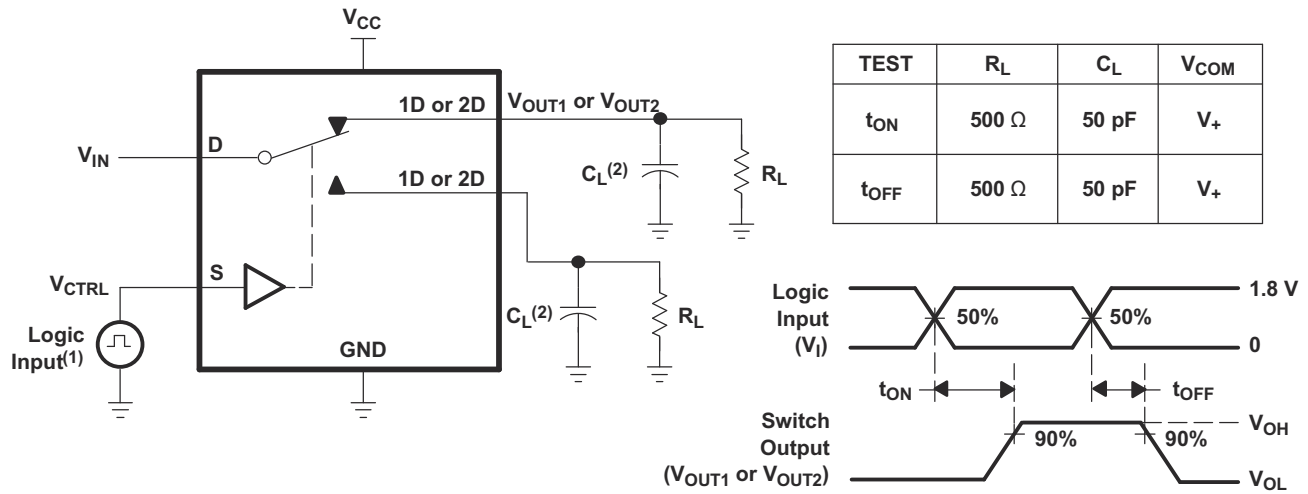

- (1) All input pulses are supplied by generators having the following characteristics: PRR ≤ 10 MHz, Z_O = 50Ω, t_r < 5 ns, t_f < 5 ns.
- (2) C_L includes probe and jig capacitance.

Figure 6-1. Turnon (T_{ON}) and Turnoff Time (T_{OFF})

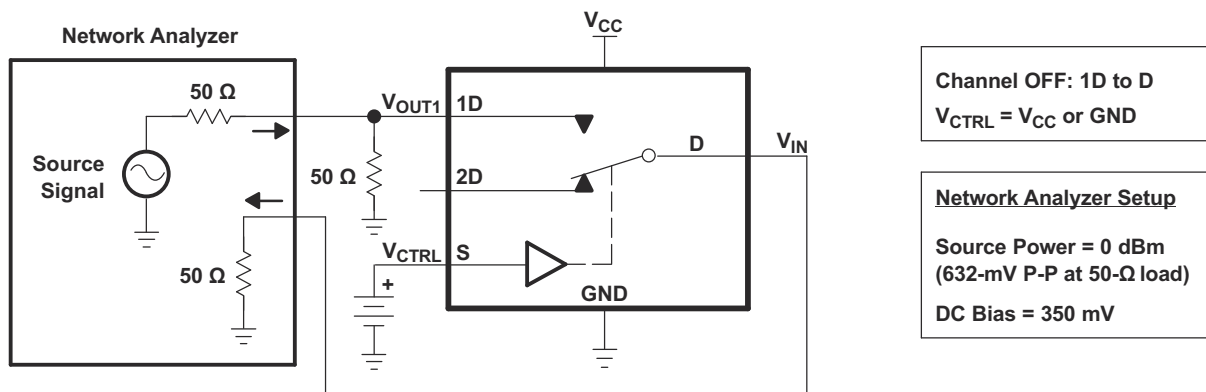

Figure 6-2. OFF Isolation (O_{ISO})

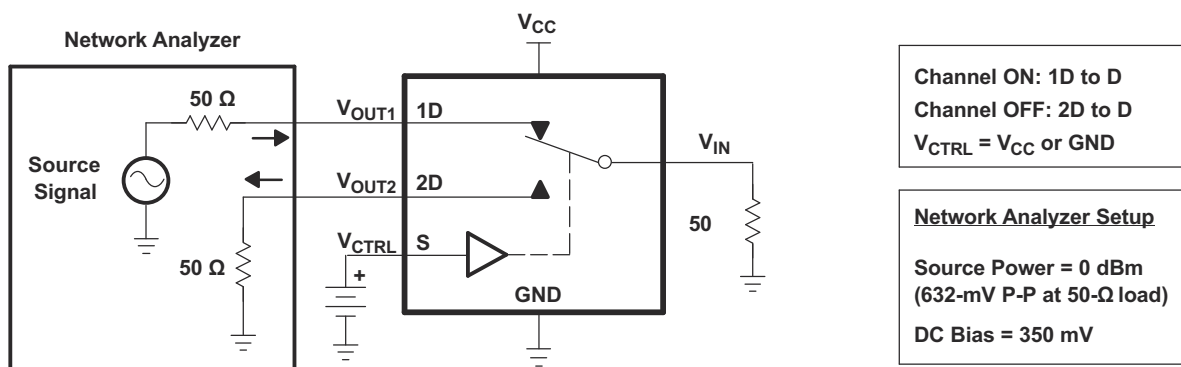

Figure 6-3. Crosstalk (X_{TALK})

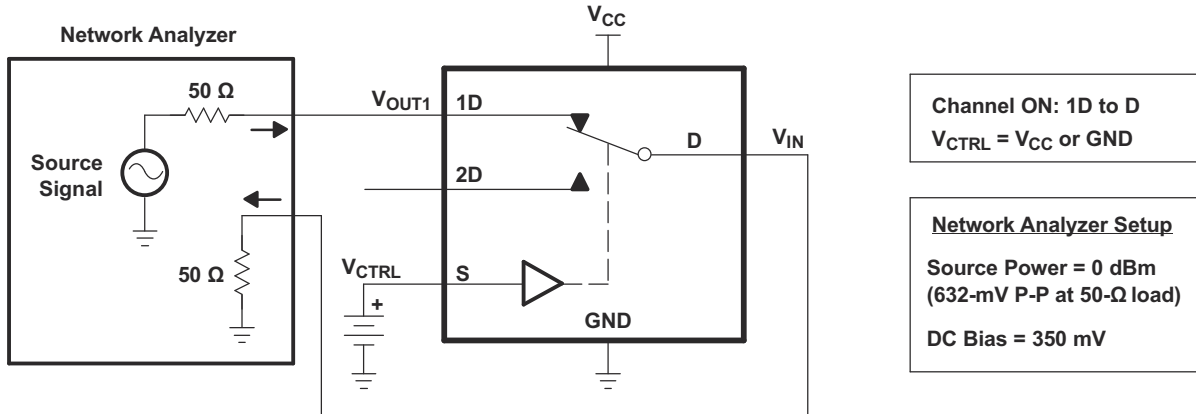

Figure 6-4. Bandwidth (BW)

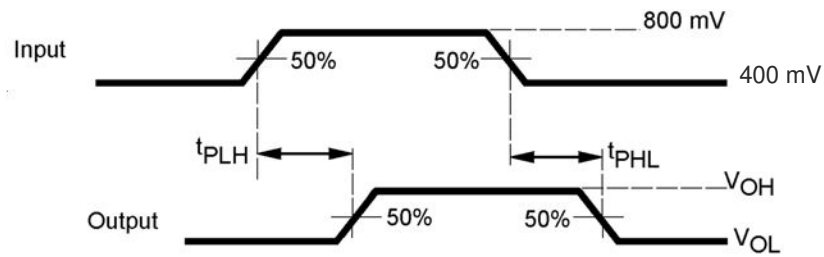

Figure 6-5. Propagation Delay

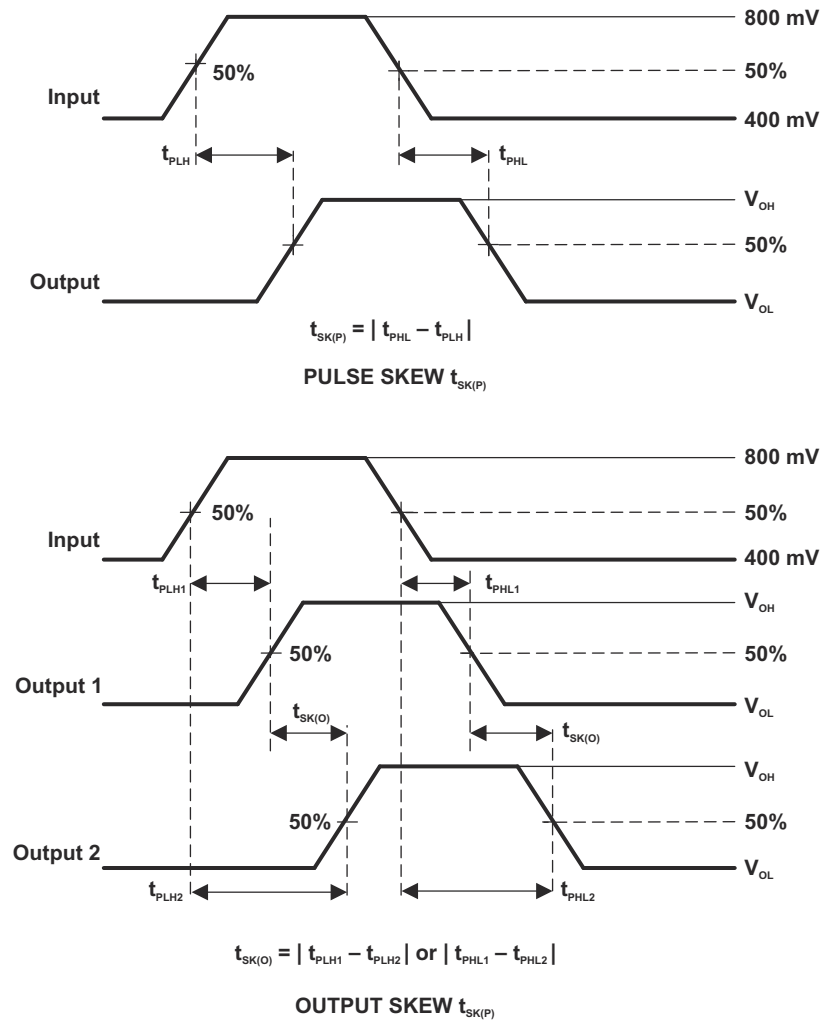

Figure 6-6. Skew Test

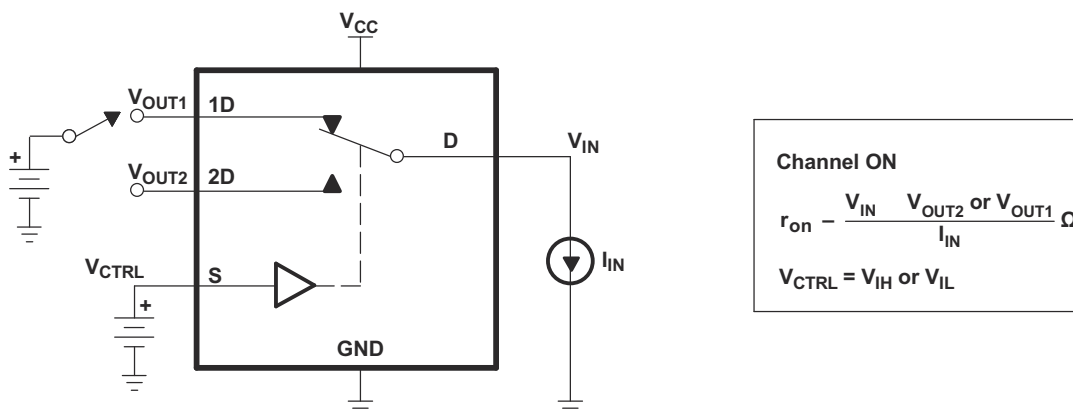
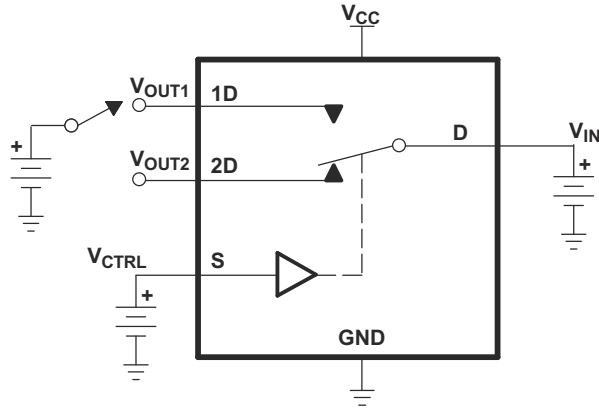
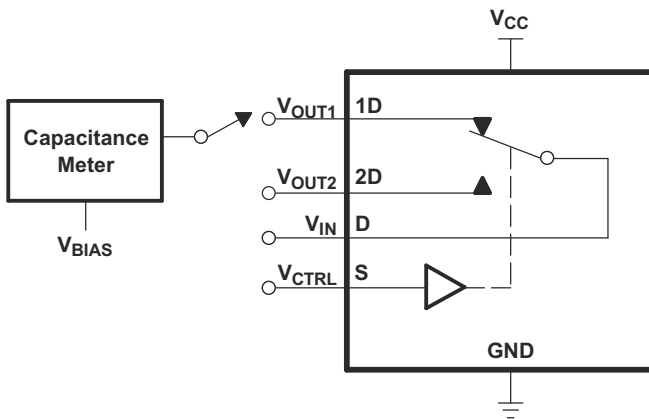

Figure 6-7. ON-State Resistance (R_{on})



OFF-State Leakage Current
 Channel OFF
 $V_{CTRL} = V_{IH}$ or V_{IL}

Figure 6-8. OFF-State Leakage Current



$V_{BIAS} = V_{CC}$ or GND
 $V_{CTRL} = V_{CC}$ or GND
 Capacitance is measured at 1D,
 2D, D, and S inputs during ON
 and OFF conditions.

Figure 6-9. Capacitance

6 Detailed Description

6.1 Overview

The TS3USB221E device is a 2-channel SPDT switch specially designed for the switching of high-speed USB 2.0 signals in handset and consumer applications, such as cell phones, digital cameras, and notebooks with hubs or controllers with limited USB I/Os. The wide bandwidth (1 GHz) of this switch allows signals to pass with minimum edge and phase distortion. The device multiplexes differential outputs from a USB host device to one of two corresponding outputs. The switch is bidirectional and offers little or no attenuation of the high-speed signals at the outputs. The device also has a low power mode that reduces the power consumption to 1 μ A for portable applications with a battery or limited power budget.

The device is designed for low bit-to-bit skew and high channel-to-channel noise isolation, and is compatible with various standards, such as high-speed USB 2.0 (480 Mbps).

The TS3USB221E device integrates ESD protection cells on all pins, is available in a SON package (3mm \times 3mm) as well as in a tiny μ QFN package (2mm \times 1.5mm) and is characterized over the free-air temperature range from -40°C to 85°C .

6.2 Functional Block Diagram

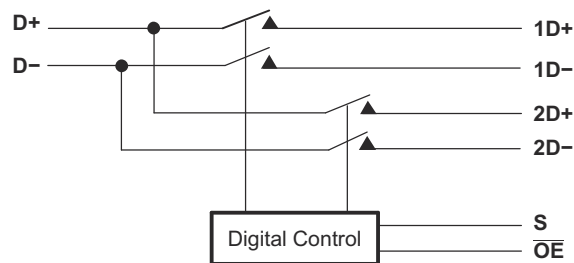

6.3 Feature Description

6.3.1 Low Power Mode

The TS3USB221E has a low power mode that reduces the power consumption to 1 μ A when the device is not in use. To put the device in low power mode and disable the switch, the bus-switch enable pin $\overline{\text{OE}}$ must be supplied with a logic high signal.

6.4 Device Functional Modes

Table 6-1. Truth Table

S	$\overline{\text{OE}}$	FUNCTION
X	H	Disconnect
L	L	D = 1D
H	L	D = 2D

7 Application and Implementation

Note

Information in the following applications sections is not part of the TI component specification, and TI does not warrant its accuracy or completeness. TI's customers are responsible for determining suitability of components for their purposes, as well as validating and testing their design implementation to confirm system functionality.

7.1 Application Information

There are many USB applications in which the USB hubs or controllers have a limited number of USB I/Os. The TS3USB221E can effectively expand the limited USB I/Os by switching between multiple USB buses to interface them to a single USB hub or controller. The TS3USB221E can also be used to connect a single controller to two USB connectors.

7.2 Typical Application

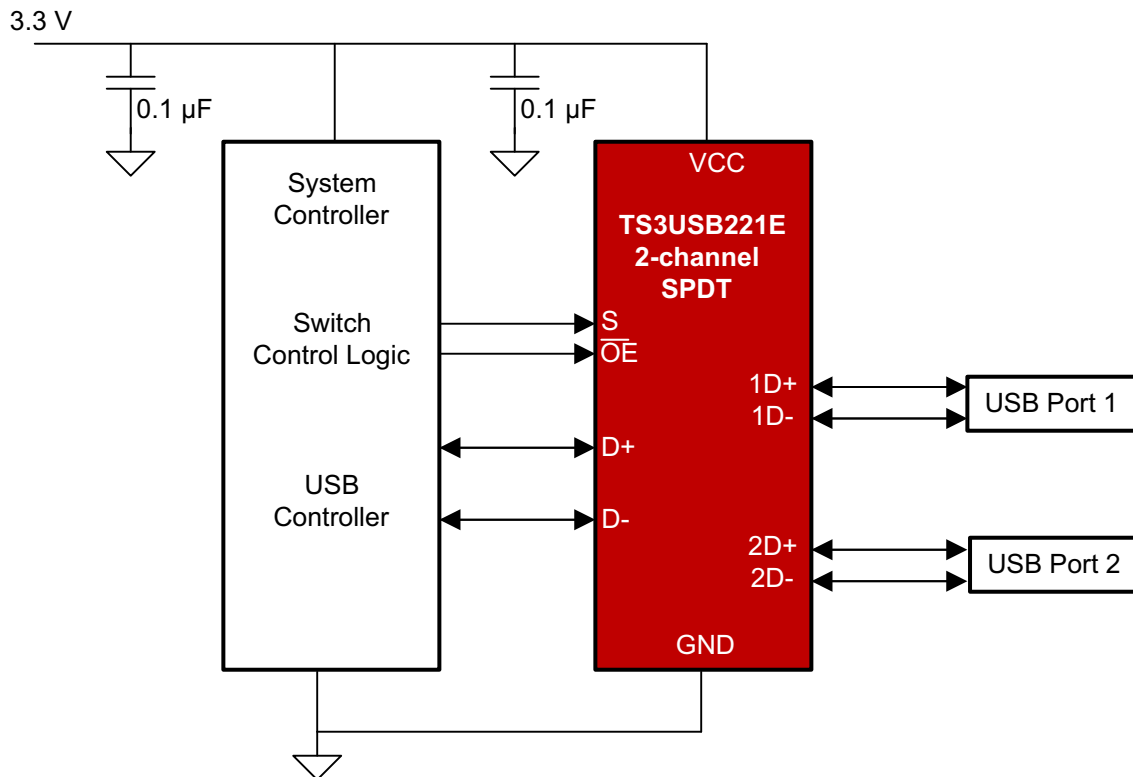

Figure 7-1. Simplified Schematic

7.2.1 Design Requirements

Follow the design requirements of the USB 1.0, 1.1, and 2.0 standards.

TI recommends that the digital control pins S and \overline{OE} be pulled up to V_{CC} or down to GND to avoid undesired switch positions that could result from the floating pin.

7.2.2 Detailed Design Procedure

The TS3USB221E can be properly operated without any external components. However, TI recommends to connect any unused pins to ground through a 50- Ω resistor to prevent signal reflections back into the device.

7.2.3 Application Curves

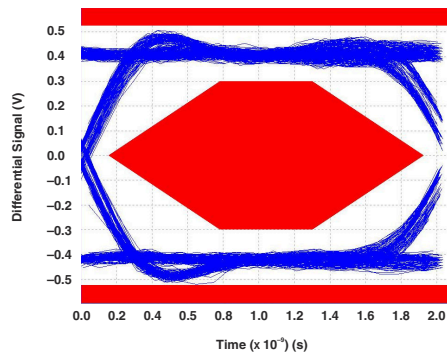

Figure 7-2. Eye Pattern: 480-Mbps USB Signal With No Switch (Through Path)

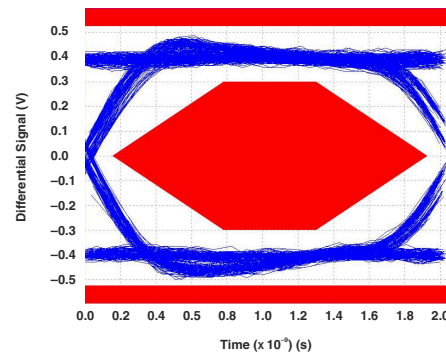

Figure 7-3. Eye Pattern: 480-Mbps USB Signal With Switch 1D Path

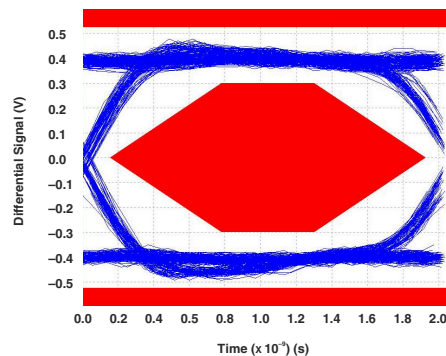

Figure 7-4. Eye Pattern: 480-Mbps USB Signal With Switch 2D Path

7.3 Power Supply Recommendations

Make sure that the power to the device supplied through the V_{CC} pin follows the USB 1.0, 1.1, and 2.0 standards. TI recommends placing a bypass capacitor as close as possible to the supply pin V_{CC} to help smooth out lower frequency noise to provide better load regulation across the frequency spectrum.

7.4 Layout

7.4.1 Layout Guidelines

Place supply bypass capacitors as close to V_{CC} pin as possible and avoid placing the bypass caps near the D+/D– traces.

The high speed D+/D– traces should always be matched lengths and must be no more than 4 inches; otherwise, the eye diagram performance can be degraded. A high-speed USB connection is made through a shielded, twisted pair cable with a differential characteristic impedance. In layout, the impedance of D+ and D– traces should match the cable characteristic differential impedance for optimal performance.

Route the high-speed USB signals using a minimum of vias and corners to reduce signal reflections and impedance changes. When a via must be used, increase the clearance size around the via to minimize the capacitance. Each via introduces discontinuities in the transmission line of the signal and increases the chance of picking up interference from the other layers of the board. Be careful when designing test points on twisted pair lines; through-hole pins are not recommended.

When it becomes necessary to turn 90°, use two 45° turns or an arc instead of making a single 90° turn. This reduces reflections on the signal traces by minimizing impedance discontinuities.

Do not route USB traces under or near crystals, oscillators, clock signal generators, switching regulators, mounting holes, magnetic devices or ICs that use or duplicate clock signals.

Avoid stubs on the high-speed USB signals because they cause signal reflections. If a stub is unavoidable, then the stub should be less than 200 mm.

Route all high-speed USB signal traces over continuous planes (V_{CC} or GND), with no interruptions.

Avoid crossing over anti-etch, commonly found with plane splits.

Due to high frequencies associated with the USB, a printed circuit board with at least four layers is recommended; two signal layers separated by a ground and power layer as shown in Figure 7-5.

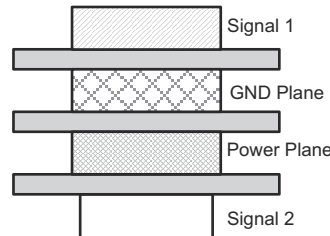

Figure 7-5. Four-Layer Board Stack-Up

The majority of signal traces should run on a single layer, preferably Signal 1. Immediately next to this layer should be the GND plane, which is solid with no cuts. Avoid running signal traces across a split in the ground or power plane. When running across split planes is unavoidable, sufficient decoupling must be used. Minimizing the number of signal vias reduces EMI by reducing inductance at high frequencies. For more information on layout guidelines, see [High Speed Layout Guidelines](#) and [USB 2.0 Board Design and Layout Guidelines](#).

7.4.2 Layout Example

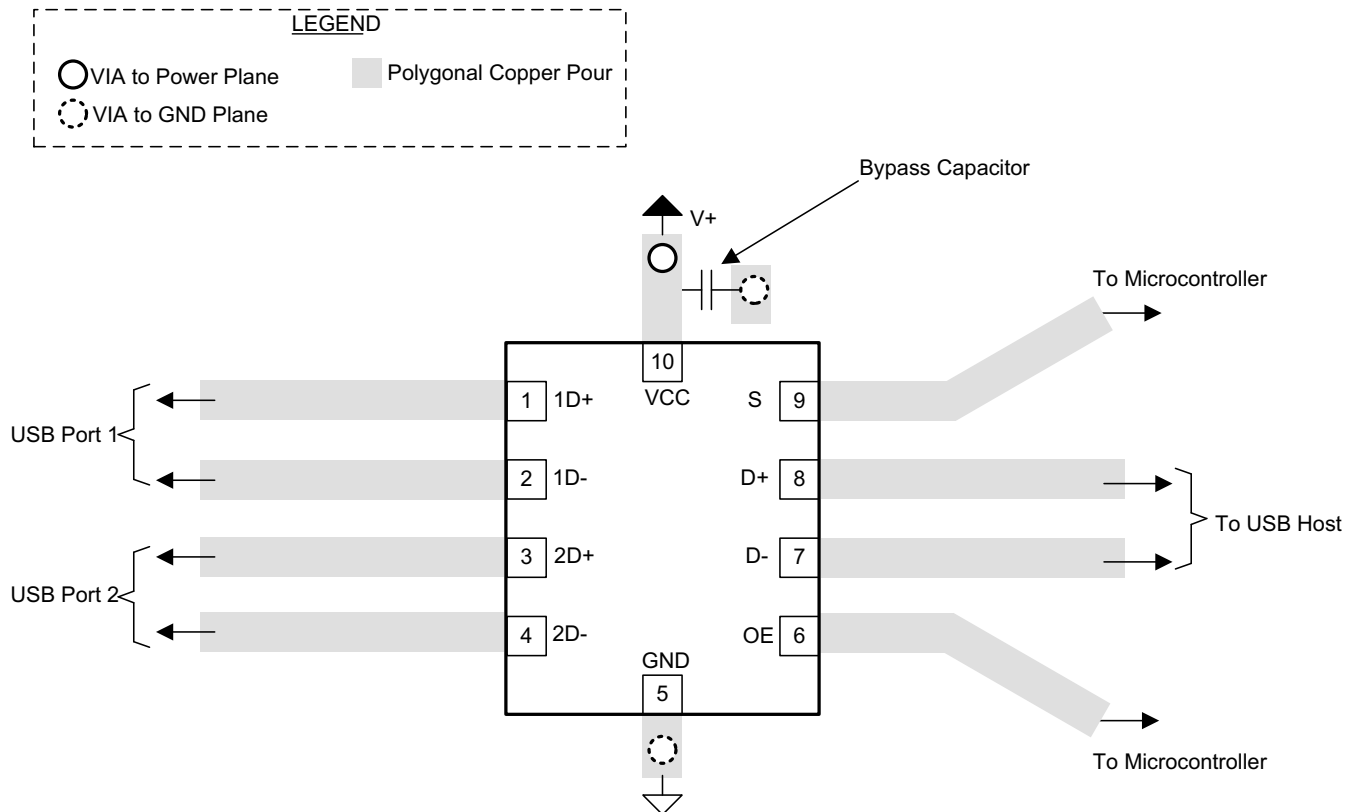

Figure 7-6. Package Layout Diagram

8 Device and Documentation Support

8.1 Documentation Support

8.1.1 Related Documentation

For related documentation, see the following:

- Texas Instruments, [Implications of Slow or Floating CMOS Inputs application note](#)
- Texas Instruments, [High Speed Layout Guidelines](#)
- Texas Instruments, [USB 2.0 Board Design and Layout Guidelines](#)

8.2 Receiving Notification of Documentation Updates

To receive notification of documentation updates, navigate to the device product folder on [ti.com](#). Click on *Notifications* to register and receive a weekly digest of any product information that has changed. For change details, review the revision history included in any revised document.

8.3 Support Resources

TI E2E™ [support forums](#) are an engineer's go-to source for fast, verified answers and design help — straight from the experts. Search existing answers or ask your own question to get the quick design help you need.

Linked content is provided "AS IS" by the respective contributors. They do not constitute TI specifications and do not necessarily reflect TI's views; see TI's [Terms of Use](#).

8.4 Trademarks

TI E2E™ is a trademark of Texas Instruments.

All trademarks are the property of their respective owners.

8.5 Electrostatic Discharge Caution



This integrated circuit can be damaged by ESD. Texas Instruments recommends that all integrated circuits be handled with appropriate precautions. Failure to observe proper handling and installation procedures can cause damage.

ESD damage can range from subtle performance degradation to complete device failure. Precision integrated circuits may be more susceptible to damage because very small parametric changes could cause the device not to meet its published specifications.

8.6 Glossary

[TI Glossary](#) This glossary lists and explains terms, acronyms, and definitions.

9 Revision History

NOTE: Page numbers for previous revisions may differ from page numbers in the current version.

Changes from Revision D (September 2019) to Revision E (July 2024)	Page
• Updated the numbering format for tables, figures, and cross-references throughout the document.....	1
• Changed ESD HBM performance testing standard from: JESD 22 to: JEDEC JS-001.....	4
• Changed ESD CDM performance testing standard from: JESD22-C101 to: JEDEC JS-002.....	4
• Added tablenote to the Data input/output voltage parameter.....	4
• Changed RSE (UQFN) junction-to-ambient thermal resistance value from: 169.8°C/W to: 204.8°C/W.....	5
• Changed RSE (UQFN) junction-to-case (top) thermal resistance value from: 84.7°C/W to: 118.1°C/W.....	5
• Changed RSE (UQFN) junction-to-board thermal resistance value from: 94.9°C/W to: 121.5°C/W.....	5
• Changed RSE (UQFN) junction-to-top characterization parameter value from: 5.7°C/W to: 13.9°C/W.....	5
• Changed RSE (UQFN) junction-to-board characterization parameter value from: 94.9°C/W to: 121.2°C/W.....	5
• Changed the V_{IK} value in the <i>Electrical Characteristics</i> table from: –1.8V maximum to: –1.8V minimum.....	5
• Changed the graphs in the <i>Typical Characteristics</i> section.....	7

Changes from Revision C (April 2015) to Revision D (September 2019)	Page
• Changed V _{CC} Operation FROM 2.5 V to 3.3 V TO 2.3 V to 3.6 V.....	1

Changes from Revision B (July 2012) to Revision C (April 2015)	Page
• Added <i>Pin Configuration and Functions</i> section, <i>ESD Ratings</i> table, <i>Thermal Information</i> table, <i>Feature Description</i> section, <i>Device Functional Modes, Application and Implementation</i> section, <i>Power Supply Recommendations</i> section, <i>Layout</i> section, <i>Device and Documentation Support</i> section, and <i>Mechanical, Packaging, and Orderable Information</i> section	1
• Removed <i>Ordering Information</i> table.....	1

Changes from Revision A (February 2010) to Revision B (July 2012)	Page
• Updated TOP-SIDE MARKING for RSE package in <i>Ordering Information</i> table.....	1

10 Mechanical, Packaging, and Orderable Information

The following pages include mechanical, packaging, and orderable information. This information is the most current data available for the designated devices. This data is subject to change without notice and revision of this document. For browser-based versions of this data sheet, refer to the left-hand navigation.

PACKAGING INFORMATION

Orderable part number	Status (1)	Material type (2)	Package Pins	Package qty Carrier	RoHS (3)	Lead finish/ Ball material (4)	MSL rating/ Peak reflow (5)	Op temp (°C)	Part marking (6)
TS3USB221EDRCR	Active	Production	VSON (DRC) 10	3000 LARGE T&R	Yes	NIPDAU	Level-2-260C-1 YEAR	-40 to 85	ZVM
TS3USB221EDRCR.A	Active	Production	VSON (DRC) 10	3000 LARGE T&R	Yes	NIPDAU	Level-2-260C-1 YEAR	-40 to 85	ZVM
TS3USB221EDRCR.B	Active	Production	VSON (DRC) 10	3000 LARGE T&R	Yes	NIPDAU	Level-2-260C-1 YEAR	-40 to 85	ZVM
TS3USB221EDRCRG4	Active	Production	VSON (DRC) 10	3000 LARGE T&R	Yes	NIPDAU	Level-2-260C-1 YEAR	-40 to 85	ZVM
TS3USB221EDRCRG4.A	Active	Production	VSON (DRC) 10	3000 LARGE T&R	Yes	NIPDAU	Level-2-260C-1 YEAR	-40 to 85	ZVM
TS3USB221EDRCRG4.B	Active	Production	VSON (DRC) 10	3000 LARGE T&R	Yes	NIPDAU	Level-2-260C-1 YEAR	-40 to 85	ZVM
TS3USB221ERSER	Active	Production	UQFN (RSE) 10	3000 LARGE T&R	Yes	NIPDAU NIPDAUAG	Level-1-260C-UNLIM	-40 to 85	(LGH, LGO, LGR, LG V)
TS3USB221ERSER.A	Active	Production	UQFN (RSE) 10	3000 LARGE T&R	Yes	NIPDAU	Level-1-260C-UNLIM	-40 to 85	(LGH, LGO, LGR, LG V)
TS3USB221ERSER.B	Active	Production	UQFN (RSE) 10	3000 LARGE T&R	Yes	NIPDAU	Level-1-260C-UNLIM	-40 to 85	(LGH, LGO, LGR, LG V)
TS3USB221ERSERG4	Active	Production	UQFN (RSE) 10	3000 LARGE T&R	Yes	NIPDAU	Level-1-260C-UNLIM	-40 to 85	LGH
TS3USB221ERSERG4.A	Active	Production	UQFN (RSE) 10	3000 LARGE T&R	Yes	NIPDAU	Level-1-260C-UNLIM	-40 to 85	LGH
TS3USB221ERSERG4.B	Active	Production	UQFN (RSE) 10	3000 LARGE T&R	Yes	NIPDAU	Level-1-260C-UNLIM	-40 to 85	LGH

(1) **Status:** For more details on status, see our [product life cycle](#).

(2) **Material type:** When designated, preproduction parts are prototypes/experimental devices, and are not yet approved or released for full production. Testing and final process, including without limitation quality assurance, reliability performance testing, and/or process qualification, may not yet be complete, and this item is subject to further changes or possible discontinuation. If available for ordering, purchases will be subject to an additional waiver at checkout, and are intended for early internal evaluation purposes only. These items are sold without warranties of any kind.

(3) **RoHS values:** Yes, No, RoHS Exempt. See the [TI RoHS Statement](#) for additional information and value definition.

(4) **Lead finish/Ball material:** Parts may have multiple material finish options. Finish options are separated by a vertical ruled line. Lead finish/Ball material values may wrap to two lines if the finish value exceeds the maximum column width.

(5) **MSL rating/Peak reflow:** The moisture sensitivity level ratings and peak solder (reflow) temperatures. In the event that a part has multiple moisture sensitivity ratings, only the lowest level per JEDEC standards is shown. Refer to the shipping label for the actual reflow temperature that will be used to mount the part to the printed circuit board.

(6) **Part marking:** There may be an additional marking, which relates to the logo, the lot trace code information, or the environmental category of the part.

Multiple part markings will be inside parentheses. Only one part marking contained in parentheses and separated by a "-" will appear on a part. If a line is indented then it is a continuation of the previous line and the two combined represent the entire part marking for that device.

Important Information and Disclaimer: The information provided on this page represents TI's knowledge and belief as of the date that it is provided. TI bases its knowledge and belief on information provided by third parties, and makes no representation or warranty as to the accuracy of such information. Efforts are underway to better integrate information from third parties. TI has taken and continues to take reasonable steps to provide representative and accurate information but may not have conducted destructive testing or chemical analysis on incoming materials and chemicals. TI and TI suppliers consider certain information to be proprietary, and thus CAS numbers and other limited information may not be available for release.

In no event shall TI's liability arising out of such information exceed the total purchase price of the TI part(s) at issue in this document sold by TI to Customer on an annual basis.

TAPE AND REEL INFORMATION

QUADRANT ASSIGNMENTS FOR PIN 1 ORIENTATION IN TAPE

*All dimensions are nominal

Device	Package Type	Package Drawing	Pins	SPQ	Reel Diameter (mm)	Reel Width W1 (mm)	A0 (mm)	B0 (mm)	K0 (mm)	P1 (mm)	W (mm)	Pin1 Quadrant
TS3USB221EDRCR	VSON	DRC	10	3000	330.0	12.4	3.3	3.3	1.1	8.0	12.0	Q2
TS3USB221EDRCRG4	VSON	DRC	10	3000	330.0	12.4	3.3	3.3	1.1	8.0	12.0	Q2
TS3USB221ERSER	UQFN	RSE	10	3000	180.0	8.4	1.68	2.13	0.76	4.0	8.0	Q1
TS3USB221ERSERG4	UQFN	RSE	10	3000	180.0	8.4	1.68	2.13	0.76	4.0	8.0	Q1

TAPE AND REEL BOX DIMENSIONS

*All dimensions are nominal

Device	Package Type	Package Drawing	Pins	SPQ	Length (mm)	Width (mm)	Height (mm)
TS3USB221EDRCR	VSON	DRC	10	3000	353.0	353.0	32.0
TS3USB221EDRCRG4	VSON	DRC	10	3000	353.0	353.0	32.0
TS3USB221ERSER	UQFN	RSE	10	3000	210.0	185.0	35.0
TS3USB221ERSERG4	UQFN	RSE	10	3000	210.0	185.0	35.0

EXAMPLE BOARD LAYOUT

RSE0010A

UQFN - 0.6 mm max height

PLASTIC QUAD FLATPACK - NO LEAD

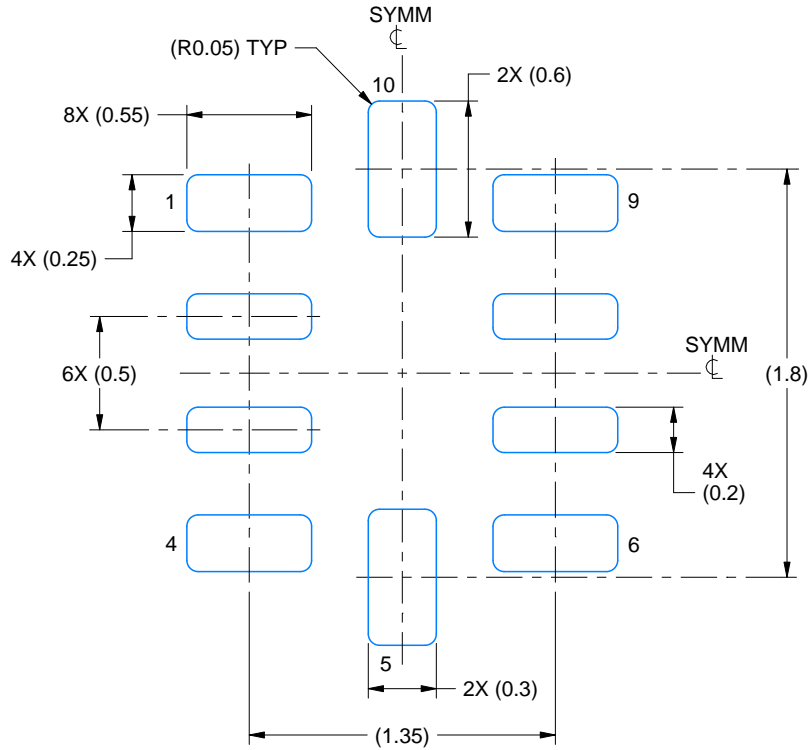

LAND PATTERN EXAMPLE
EXPOSED METAL SHOWN
SCALE:30X

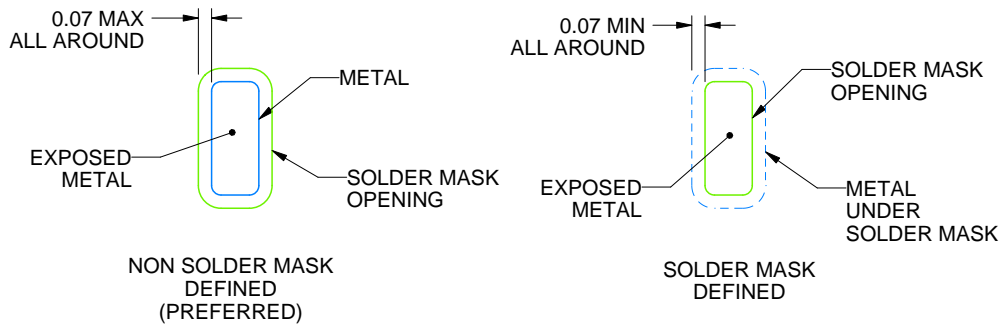

SOLDER MASK DETAILS
NOT TO SCALE

4220307/A 03/2020

NOTES: (continued)

3. For more information, see Texas Instruments literature number SLUA271 (www.ti.com/lit/slua271).

GENERIC PACKAGE VIEW

DRC 10

VSON - 1 mm max height

3 x 3, 0.5 mm pitch

PLASTIC SMALL OUTLINE - NO LEAD

This image is a representation of the package family, actual package may vary.
Refer to the product data sheet for package details.

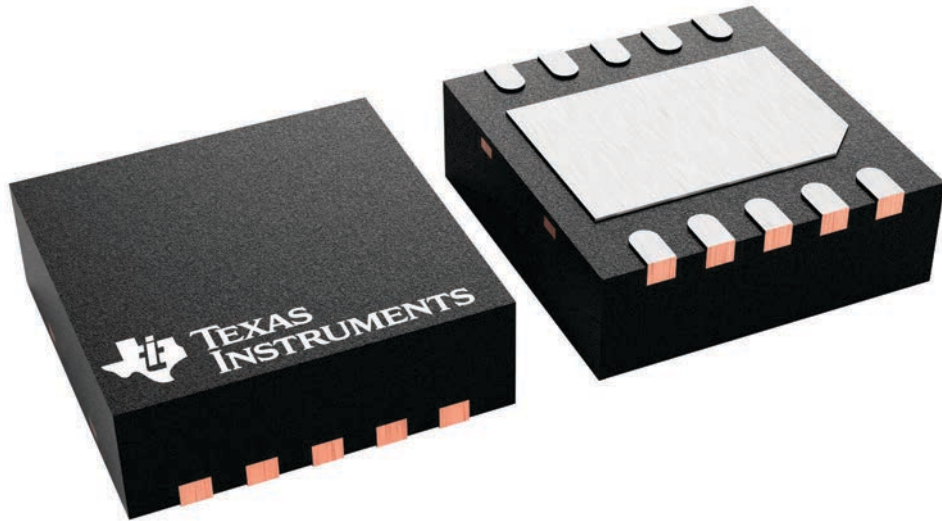

4226193/A

EXAMPLE STENCIL DESIGN

DRC0010J

VSON - 1 mm max height

PLASTIC SMALL OUTLINE - NO LEAD

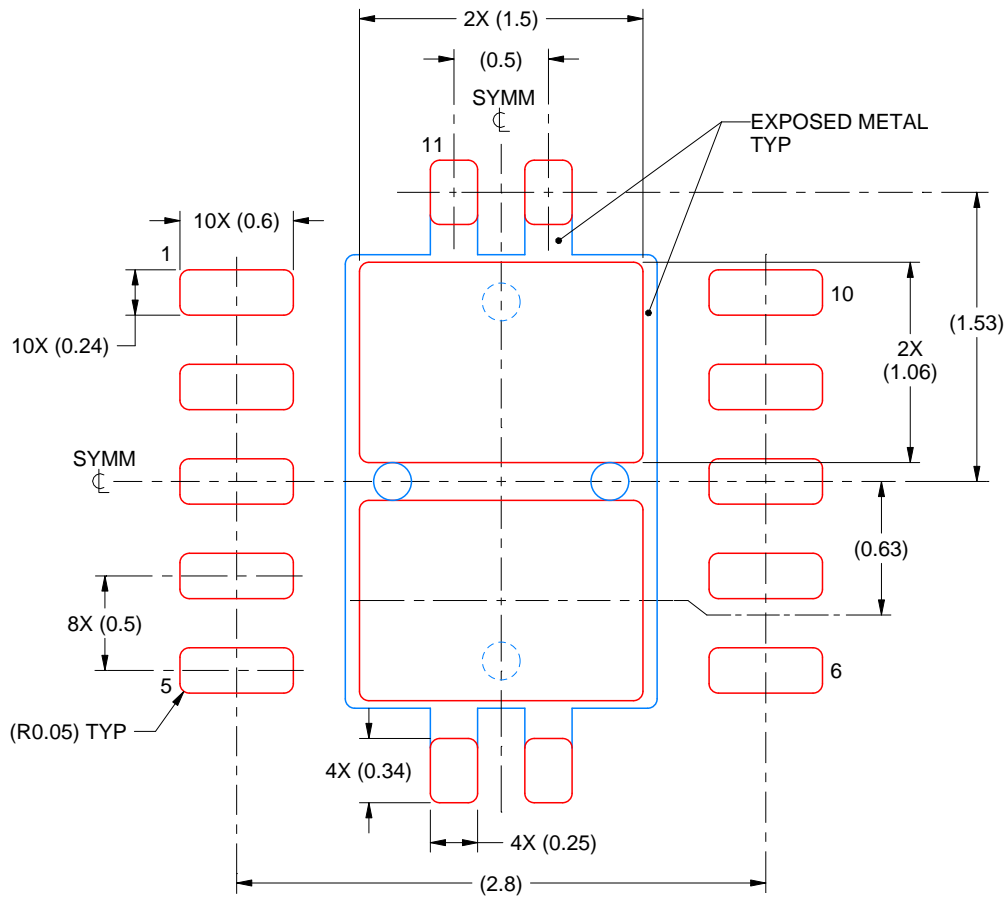

SOLDER PASTE EXAMPLE
BASED ON 0.125 mm THICK STENCIL

EXPOSED PAD 11:
80% PRINTED SOLDER COVERAGE BY AREA
SCALE:25X

4218878/B 07/2018

NOTES: (continued)

6. Laser cutting apertures with trapezoidal walls and rounded corners may offer better paste release. IPC-7525 may have alternate design recommendations.

IMPORTANT NOTICE AND DISCLAIMER

TI PROVIDES TECHNICAL AND RELIABILITY DATA (INCLUDING DATASHEETS), DESIGN RESOURCES (INCLUDING REFERENCE DESIGNS), APPLICATION OR OTHER DESIGN ADVICE, WEB TOOLS, SAFETY INFORMATION, AND OTHER RESOURCES "AS IS" AND WITH ALL FAULTS, AND DISCLAIMS ALL WARRANTIES, EXPRESS AND IMPLIED, INCLUDING WITHOUT LIMITATION ANY IMPLIED WARRANTIES OF MERCHANTABILITY, FITNESS FOR A PARTICULAR PURPOSE OR NON-INFRINGEMENT OF THIRD PARTY INTELLECTUAL PROPERTY RIGHTS.

These resources are intended for skilled developers designing with TI products. You are solely responsible for (1) selecting the appropriate TI products for your application, (2) designing, validating and testing your application, and (3) ensuring your application meets applicable standards, and any other safety, security, regulatory or other requirements.

These resources are subject to change without notice. TI grants you permission to use these resources only for development of an application that uses the TI products described in the resource. Other reproduction and display of these resources is prohibited. No license is granted to any other TI intellectual property right or to any third party intellectual property right. TI disclaims responsibility for, and you fully indemnify TI and its representatives against any claims, damages, costs, losses, and liabilities arising out of your use of these resources.

TI's products are provided subject to [TI's Terms of Sale](#), [TI's General Quality Guidelines](#), or other applicable terms available either on ti.com or provided in conjunction with such TI products. TI's provision of these resources does not expand or otherwise alter TI's applicable warranties or warranty disclaimers for TI products. Unless TI explicitly designates a product as custom or customer-specified, TI products are standard, catalog, general purpose devices.

TI objects to and rejects any additional or different terms you may propose.

Copyright © 2026, Texas Instruments Incorporated

Last updated 10/2025