

TPS795 Ultra-Low-Noise, High-PSRR, Fast, RF, 500mA, Low-Dropout Linear Regulator

1 Features

- 500mA low-dropout regulator with enable
- Available in fixed and adjustable versions
- High PSRR (50dB at 10kHz)
- Low noise
 - 33 μ V_{RMS} (legacy chip)
 - 78 μ V_{RMS} (new chip)
- Stable with a 1 μ F ceramic capacitor
- Excellent load and line transient response
- Low dropout voltage: 110mV (typ)
- 6-pin SOT-223 and 3mm \times 3mm VSON packages
- For a more updated portfolio device, see the [TPS7A90](#)

2 Applications

- [TV applications](#)
- [Building automation](#)
- [Connected peripherals and printers](#)
- [Home theater and entertainment applications](#)

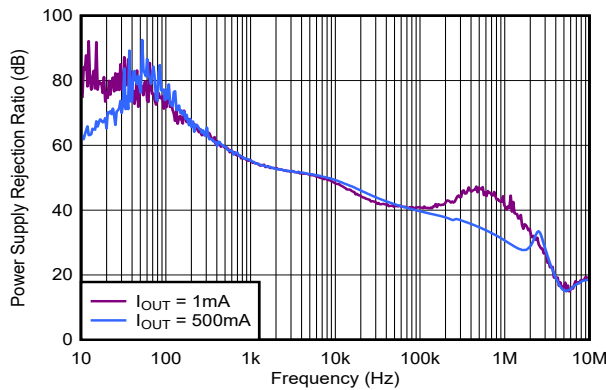

TPS795 Ripple Rejection vs Frequency

3 Description

The TPS795 low-dropout (LDO), low-power linear voltage regulator features high power-supply rejection ratio (PSRR), ultra-low noise, fast start-up, and excellent line and load transient responses in 6-pin SOT-223 and 3mm \times 3mm VSON packages. The TPS795 is stable with a small 1 μ F ceramic capacitor on the output. The TPS795 offers low dropout voltages (for example, 110mV at 500mA). Applications with analog components that are noise-sensitive, such as portable RF electronics, benefit from the high-PSRR and low-noise features, as well as from the fast response time.

Package Information

PART NUMBER	PACKAGE ⁽¹⁾	PACKAGE SIZE ⁽²⁾
TPS795	DCQ (SOT-223, 6)	6.5mm \times 7.06mm
	DRB (VSON, 8)	3mm \times 3mm

- (1) For more information, see the [Mechanical, Packaging, and Orderable Information](#).
- (2) The package size (length \times width) is a nominal value and includes pins, where applicable.

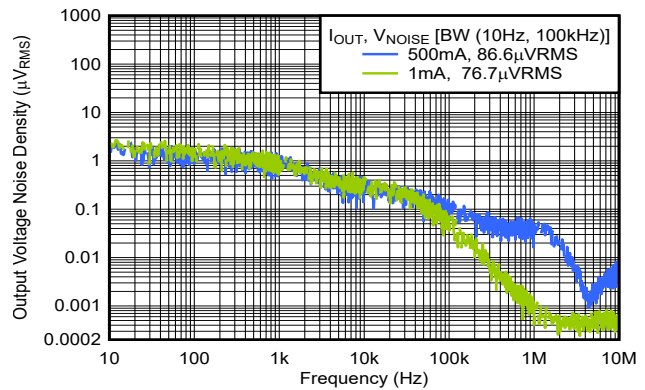

TPS795 Output Voltage Noise



Table of Contents

1 Features	1	7.1 Application Information.....	19
2 Applications	1	7.2 Typical Application.....	19
3 Description	1	7.3 Best Design Practices.....	22
4 Pin Configuration and Functions	3	7.4 Power Supply Recommendations.....	23
5 Specifications	4	7.5 Layout.....	23
5.1 Absolute Maximum Ratings.....	4	8 Device and Documentation Support	29
5.2 ESD Ratings.....	4	8.1 Device Support.....	29
5.3 Recommended Operating Conditions.....	5	8.2 Documentation Support.....	29
5.4 Thermal Information.....	5	8.3 Receiving Notification of Documentation Updates....	29
5.5 Electrical Characteristics.....	6	8.4 Support Resources.....	29
5.6 Typical Characteristics.....	7	8.5 Trademarks.....	30
6 Detailed Description	14	8.6 Electrostatic Discharge Caution.....	30
6.1 Overview.....	14	8.7 Glossary.....	30
6.2 Functional Block Diagrams.....	14	9 Revision History	30
6.3 Feature Description.....	15	10 Mechanical, Packaging, and Orderable Information	30
6.4 Device Functional Modes.....	18		
7 Application and Implementation	19		

4 Pin Configuration and Functions

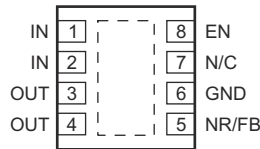

Figure 4-1. DRB Package, 8-Pin VSON (Top View, Legacy Chip)

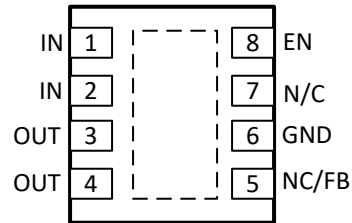

Figure 4-2. DRB Package, 8-Pin VSON (Top View, New Chip)

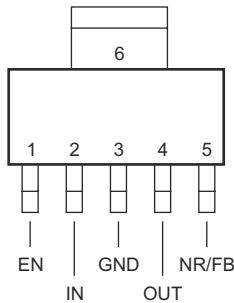

Figure 4-3. DCQ Package, 6-Pin SOT-223 (Top View, Legacy Chip)

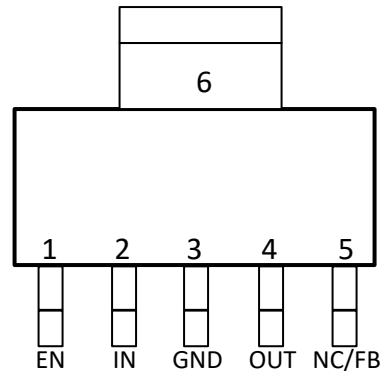

Figure 4-4. DCQ Package, 6-Pin SOT-223 (Top View, New Chip)

Table 4-1. Pin Functions

NAME	PIN		TYPE ⁽¹⁾	DESCRIPTION
	VSON	SOT-223		
EN	8	1	Input	Driving the enable pin (EN) high turns on the regulator. Driving this pin low puts the regulator into shutdown mode. EN can be connected to IN if not used.
FB	5	5	Input	Feedback input voltage for the adjustable device.
GND	6	3, 6	—	Regulator ground
IN	1, 2	2	Input	Input to the device.
N/C	5, 7	5	—	No internal connection
NR	5	5	—	Legacy chip: Noise-reduction pin for fixed versions only. Connecting an external capacitor to this pin bypasses noise generated by the internal band gap, which improves power-supply rejection and reduces output noise. (Not available on adjustable versions.) For lower noise performance device, consider the TPS7A90 .
OUT	3, 4	4	Output	Regulator output
Thermal Pad	Pad	—	—	Connect the thermal pad to a large-area ground plane. The thermal pad is internally connected to GND.

(1) I=Input; O=Output

5 Specifications

5.1 Absolute Maximum Ratings

over operating free-air temperature range (unless otherwise noted)⁽¹⁾

		MIN	MAX	UNIT
Voltage	Supply, V _{IN} (New chip)	-0.3	6.5	V
	Supply, V _{IN} (Legacy chip)	-0.3	6	
	Enable, V _{EN}	-0.3	V _{IN} + 0.3	
	Output, V _{OUT}	-0.3	6	
Current	Output, I _{OUT}	Internally limited		
Temperature	Operating junction, T _J	-40	150	°C
	Storage, T _{stg}	-65	150	

- (1) Operation outside the Absolute Maximum Ratings may cause permanent device damage. Absolute Maximum Ratings do not imply functional operation of the device at these or any other conditions beyond those listed under Recommended Operating Conditions. If used outside the Recommended Operating Conditions but within the Absolute Maximum Ratings, the device may not be fully functional, and this may affect device reliability, functionality, performance, and shorten the device lifetime

5.2 ESD Ratings

			VALUE	UNIT
V _(ESD)	Electrostatic discharge	Human body model (HBM), per ANSI/ESDA/JEDEC JS-001, all pins ⁽¹⁾	±2000	V
V _(ESD)	Electrostatic discharge	Charged device model (CDM), per JEDEC specification JESD22C101, V all pins ⁽²⁾	±500	V

- (1) JEDEC document JEP155 states that 500V HBM allows safe manufacturing with a standard ESD control process.
 (2) JEDEC document JEP157 states that 250V CDM allows safe manufacturing with a standard ESD control process.

5.3 Recommended Operating Conditions

over operating free-air temperature range (unless otherwise noted)

		MIN	NOM	MAX	UNIT
V _{IN}	Input supply voltage (legacy chip)	2.7		5.5	V
	Input supply voltage (new chip)	2.7		6.0	
C _{IN}	Input capacitor	2.2			μF
C _{OUT}	Output capacitor	1 ⁽¹⁾		200	
C _{FF}	Feed-forward capacitor (new chip)	0	10	100	nF
I _{OUT}	Output current	0		500	mA
V _{EN}	Enable voltage (legacy chip)	0		5.5	V
	Enable voltage (new chip)	0		6.0	
F _{EN}	Enable toggle frequency (new chip)			10	kHz
T _J	Junction Temperature	-40		125	°C

(1) The minimum effective capacitance is 0.47 μF.

5.4 Thermal Information

THERMAL METRIC ⁽¹⁾		TPS795		TPS795		UNIT
		DRB (VSON)		DCQ (SOT223-6)		
		8 PINS ⁽²⁾	8 PINS ⁽³⁾	6 PINS ⁽²⁾	6 PINS ⁽³⁾	
R _{θJA}	Junction-to-ambient thermal resistance	46.8	54.7	74.0	71.1	°C/W
R _{θJC(top)}	Junction-to-case (top) thermal resistance	45.1	76.1	44.5	41.6	°C/W
R _{θJB}	Junction-to-board thermal resistance	18.4	30.1	8.6	8.8	°C/W
ψ _{JT}	Junction-to-top characterization parameter	0.7	6.6	3.2	3.5	°C/W
ψ _{JB}	Junction-to-board characterization parameter	18.4	30.2	8.5	8.5	°C/W
R _{θJC(bot)}	Junction-to-case (bottom) thermal resistance	5.3	16.7	N/A	6	°C/W

(1) For more information about traditional and new thermal metrics, see the "[Semiconductor and IC Package Thermal Metrics](#)" application note.

(2) Legacy chip.

(3) New chip.

5.5 Electrical Characteristics

at operating temperature range ($T_J = -40^{\circ}\text{C}$ to $+125^{\circ}\text{C}$), $V_{EN} = V_{IN}$, $V_{IN} = V_{OUT(nom)} + 1\text{V}$ ⁽¹⁾, $I_{OUT} = 1\text{mA}$, and $C_{OUT} = 10\mu\text{F}$ and $C_{NR} = 0.01\mu\text{F}$ (Legacy Chip only), unless otherwise noted. All typical values at $T_J = 25^{\circ}\text{C}$.

PARAMETER		TEST CONDITIONS		MIN	TYP	MAX	UNIT
V_{FB}	Internal reference (TPS79501)			1.2	1.225	1.25	V
V_{OUT}	Output voltage range (TPS79501)			1.225		$5.5V_{DO}$	V
V_{OUT}	Output accuracy	TPS79501 (legacy chip)	$0\mu\text{A} \leq I_{OUT} \leq 500\text{mA}$, $V_{OUT(nom)} + 1\text{V} \leq V_{IN} \leq 5.5\text{V}$ ⁽¹⁾	$0.98V_{OUT(nom)}$		$1.02V_{OUT(nom)}$	%
		TPS79501 (new chip)	$0\mu\text{A} \leq I_{OUT} \leq 500\text{mA}$, $V_{OUT(nom)} + 1\text{V} \leq V_{IN} \leq 5.5\text{V}$ ⁽¹⁾	$0.975V_{OUT(nom)}$		$1.02V_{OUT(nom)}$	
		Fixed $V_{OUT} < 5\text{V}$	$0\mu\text{A} \leq I_{OUT} \leq 500\text{mA}$, $V_{OUT(nom)} + 1\text{V} \leq V_{IN} \leq 5.5\text{V}$ ⁽¹⁾	-2.0		2.0	
$\Delta V_{OUT}/\Delta V_{IN}$	Line regulation	$V_{OUT} + 1\text{V} \leq V_{IN} \leq 5.5\text{V}$			0.05	0.12	%/V
$\Delta V_{OUT}/\Delta I_{OUT}$	Load regulation	$0\mu\text{A} \leq I_{OUT} \leq 500\text{mA}$			3		mV
V_{DO}	Dropout voltage TPS79530	$V_{IN} = V_{OUT} - 0.1\text{V}$	$I_{OUT} = 500\text{mA}$		110	170	mV
	Dropout voltage TPS79533		$I_{OUT} = 500\text{mA}$		105	160	
I_{CL}	Output current limit	$V_{OUT} = 0$ (legacy chip)		2.4	2.8	4.2	A
I_{CL}	Output current limit	$V_{IN} = V_{OUT(nom)} + 1.25\text{V}$ or 2.0V (whichever is greater), $V_{OUT} = 0.9 \times V_{OUT(nom)}$ (new chip only) ⁽²⁾		1.04		1.65	A
I_{SC}	Short-circuit current limit	$V_{OUT} = 0$ (new chip only)			550		mA
I_{GND}	Ground current	$0\mu\text{A} \leq I_{OUT} \leq 500\text{mA}$ (legacy chip)			265	385	μA
I_{GND}	Ground current	$0\mu\text{A} \leq I_{OUT} \leq 500\text{mA}$ (new chip)			500	900	μA
I_{SHDN}	Shutdown current	$V_{EN} = 0\text{V}$, $2.7\text{V} \leq V_{IN} \leq 5.5\text{V}$			0.07	1	μA
I_{FB}	Feedback pin current	$V_{FB} = 1.225\text{V}$				1	μA
PSRR	Power-supply rejection ratio (TPS79530)	$f = 100\text{Hz}$, $I_{OUT} = 10\text{mA}$ (legacy chip)			59		dB
		$f = 100\text{Hz}$, $I_{OUT} = 10\text{mA}$ (new chip)			64		
		$f = 100\text{Hz}$, $I_{OUT} = 500\text{mA}$ (legacy chip)			58		
		$f = 100\text{Hz}$, $I_{OUT} = 500\text{mA}$ (new chip)			76		
		$f = 10\text{kHz}$, $I_{OUT} = 500\text{mA}$ (legacy chip)			50		
		$f = 10\text{kHz}$, $I_{OUT} = 500\text{mA}$ (new chip)			49		
		$f = 100\text{kHz}$, $I_{OUT} = 500\text{mA}$ (legacy chip)			39		
		$f = 100\text{kHz}$, $I_{OUT} = 500\text{mA}$ (new chip)			39		
V_n	Output noise voltage (TPS79530)	$BW = 100\text{Hz}$ to 100kHz , $I_{OUT} = 500\text{mA}$	$C_{NR} = 0.001\mu\text{F}$		46		μV_{RMS}
			$C_{NR} = 0.0047\mu\text{F}$		41		
			$C_{NR} = 0.01\mu\text{F}$		35		
			$C_{NR} = 0.1\mu\text{F}$		33		
		$BW = 10\text{Hz}$ to 100kHz , $I_{OUT} = 500\text{mA}$	New Chip		78		
t_{str}	Time, start-up	$R_L = 6\Omega$, $C_{OUT} = 1\mu\text{F}$	$C_{NR} = 0.001\mu\text{F}$		50		μs
		$R_L = 6\Omega$, $C_{OUT} = 1\mu\text{F}$	$C_{NR} = 0.0047\mu\text{F}$		75		
		$R_L = 6\Omega$, $C_{OUT} = 1\mu\text{F}$	$C_{NR} = 0.01\mu\text{F}$		110		
t_{str}	Time, start-up	$R_L = 6\Omega$, $C_{OUT} = 1\mu\text{F}$	new chip		550		μs
I_{EN}	Enable pin current	$V_{EN} = 0\text{V}$		-1		1	μA
$R_{PULLDOWN}$	Pulldown resistance	$V_{IN} = 3.3\text{V}$ (new chip only)			100		Ω
V_{UVLO}	UVLO threshold	V_{IN} rising (legacy chip)		2.25		2.65	V
		V_{IN} rising (new chip)		1.28		1.62	
$V_{UVLO(HYST)}$	UVLO hysteresis	V_{IN} hysteresis (legacy chip)			100		mV
		V_{IN} hysteresis (new Chip)			130		

5.5 Electrical Characteristics (continued)

at operating temperature range ($T_J = -40^{\circ}\text{C}$ to $+125^{\circ}\text{C}$), $V_{EN} = V_{IN}$, $V_{IN} = V_{OUT(nom)} + 1\text{V}$ ⁽¹⁾, $I_{OUT} = 1\text{mA}$, and $C_{OUT} = 10\mu\text{F}$ and $C_{NR} = 0.01\mu\text{F}$ (Legacy Chip only), unless otherwise noted. All typical values at $T_J = 25^{\circ}\text{C}$.

PARAMETER		TEST CONDITIONS		MIN	TYP	MAX	UNIT
$V_{EN(HI)}$	High-level enable input voltage	$2.7\text{V}^{(1)} \leq V_{IN} \leq 5.5\text{V}$ (legacy chip)		1.7		V_{IN}	V
		$2.7\text{V}^{(1)} \leq V_{IN} \leq 5.5\text{V}$ (new chip)		0.85		V_{IN}	
$V_{EN(LOW)}$	Low-level enable input voltage	$2.7\text{V}^{(1)} \leq V_{IN} \leq 5.5\text{V}$ (legacy chip)				0.7	
		$2.7\text{V}^{(1)} \leq V_{IN} \leq 5.5\text{V}$ (new chip)				0.425	
T_{SD}	Thermal shutdown temperature	Shutdown, temperature increasing	legacy chip		165		$^{\circ}\text{C}$
T_{SD}	Thermal shutdown temperature	Shutdown, temperature increasing	new chip		170		$^{\circ}\text{C}$
T_{SD}	Thermal shutdown temperature	Reset, temperature decreasing	legacy chip		140		$^{\circ}\text{C}$
T_{SD}	Thermal shutdown temperature	Reset, temperature decreasing	new chip		155		$^{\circ}\text{C}$

- (1) Minimum $V_{IN} = V_{OUT} + 1\text{V}$ or 2.7V , whichever is greater.
- (2) $V_{OUT(NOM)} = 5\text{V}$ is tested at $V_{IN(NOM)} = V_{OUT(NOM)} + 1\text{V}$

5.6 Typical Characteristics

at $V_{EN} = V_{IN}$, $V_{IN} = V_{OUT(nom)} + 1\text{V}$, $I_{OUT} = 1\text{mA}$, $C_{OUT} = 10\mu\text{F}$, $C_{NR} = 0.01\mu\text{F}$, $C_{IN} = 2.2\mu\text{F}$, and $T_J = 25^{\circ}\text{C}$ (unless otherwise noted)

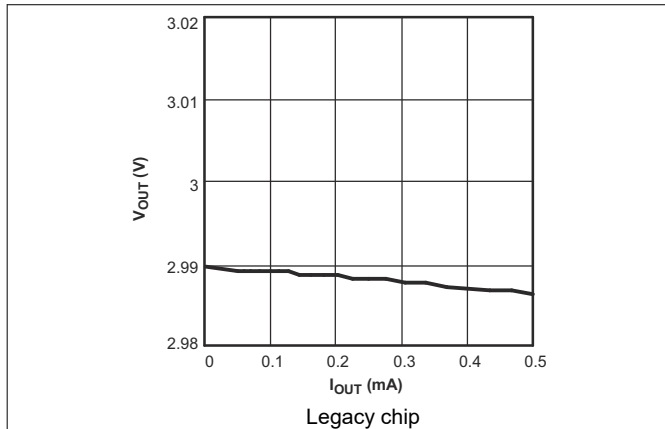

Figure 5-1. TPS795 Output Voltage vs Output Current

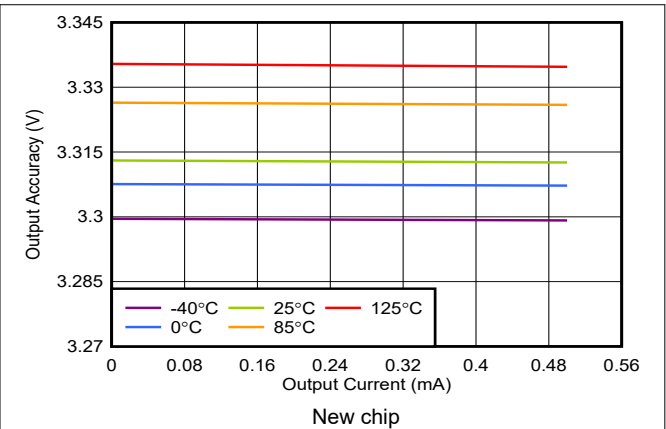

Figure 5-2. TPS795 Output Voltage vs Output Current

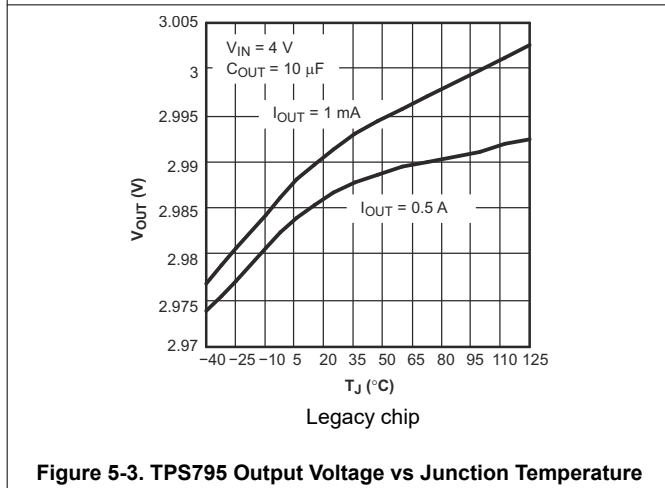

Figure 5-3. TPS795 Output Voltage vs Junction Temperature

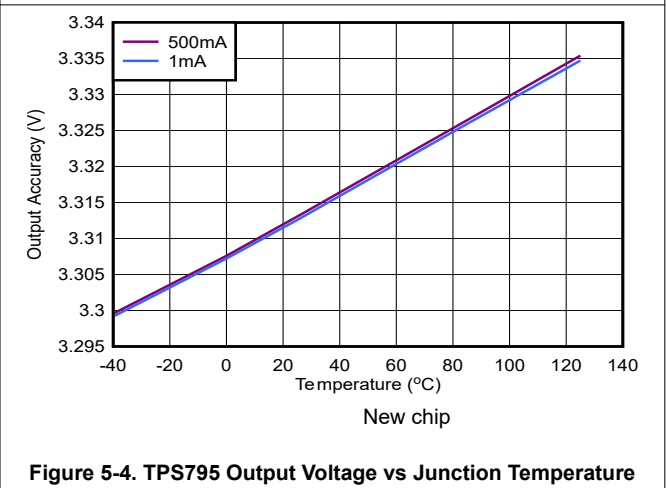

Figure 5-4. TPS795 Output Voltage vs Junction Temperature

5.6 Typical Characteristics (continued)

at $V_{EN} = V_{IN}$, $V_{IN} = V_{OUT(nom)} + 1V$, $I_{OUT} = 1mA$, $C_{OUT} = 10 \mu F$, $C_{NR} = 0.01 \mu F$, $C_{IN} = 2.2 \mu F$, and $T_J = 25^\circ C$ (unless otherwise noted)

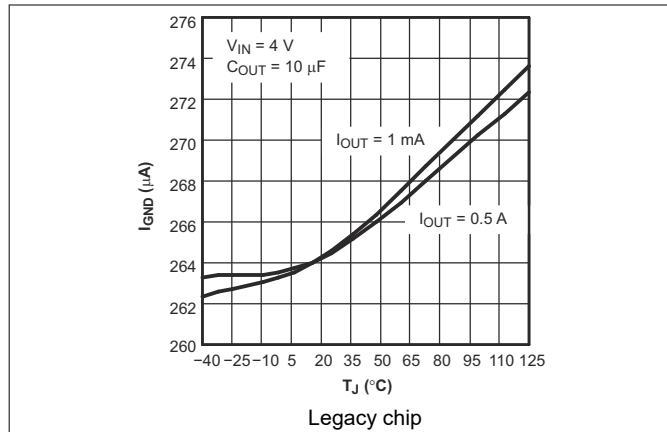

Figure 5-5. TPS795 Ground Current vs Junction Temperature

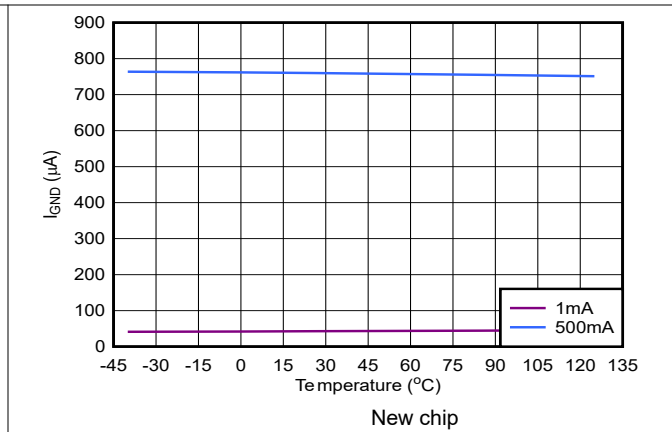

Figure 5-6. TPS795 Ground Current vs Junction Temperature

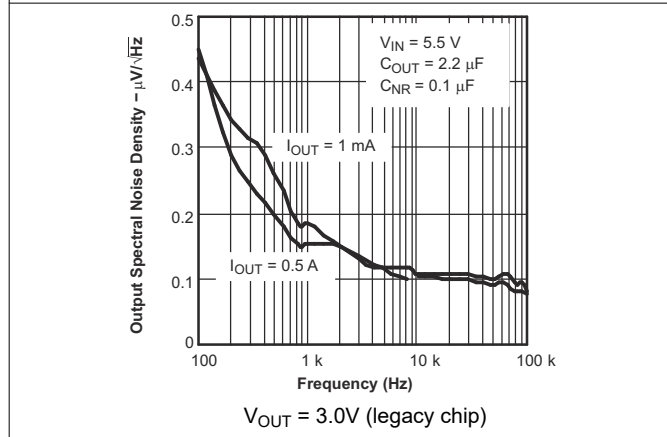

Figure 5-7. TPS795 Output Spectral Noise Density vs Frequency

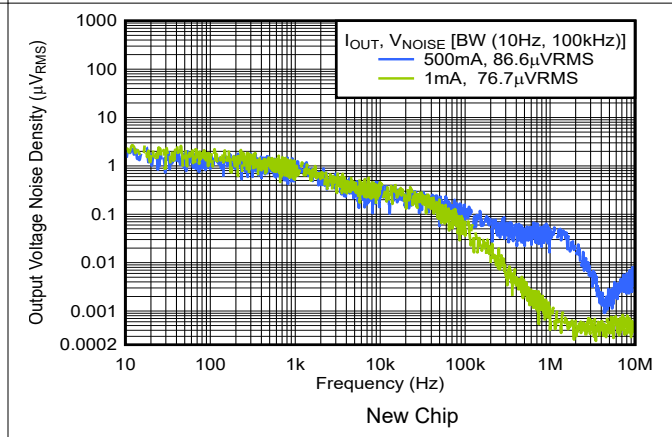

Figure 5-8. TPS795 Output Spectral Noise Density vs Frequency

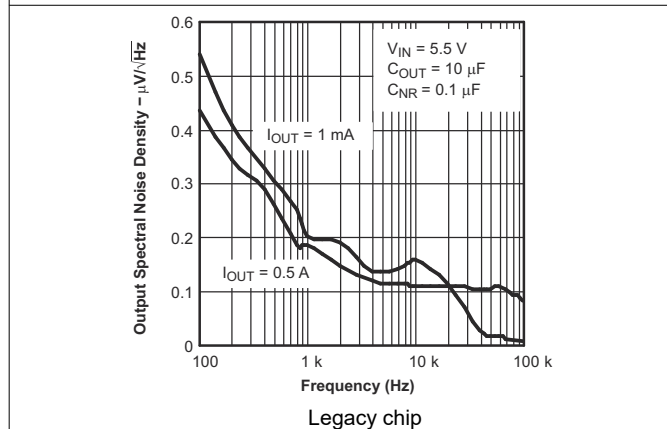

Figure 5-9. TPS79530 Output Spectral Noise Density vs Frequency

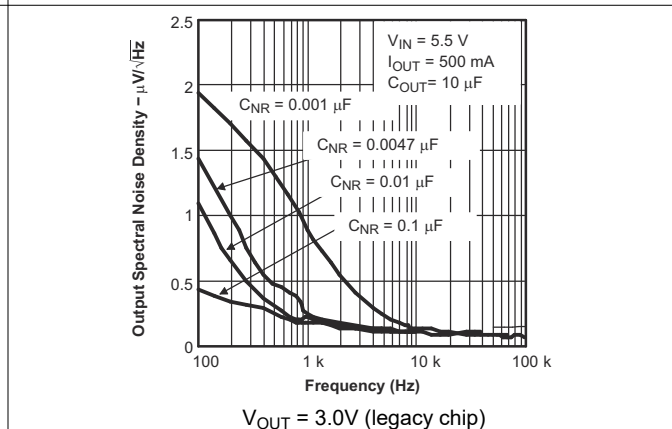

Figure 5-10. TPS795 Output Spectral Noise Density vs Frequency

5.6 Typical Characteristics (continued)

at $V_{EN} = V_{IN}$, $V_{IN} = V_{OUT(nom)} + 1V$, $I_{OUT} = 1mA$, $C_{OUT} = 10 \mu F$, $C_{NR} = 0.01 \mu F$, $C_{IN} = 2.2 \mu F$, and $T_J = 25^\circ C$ (unless otherwise noted)

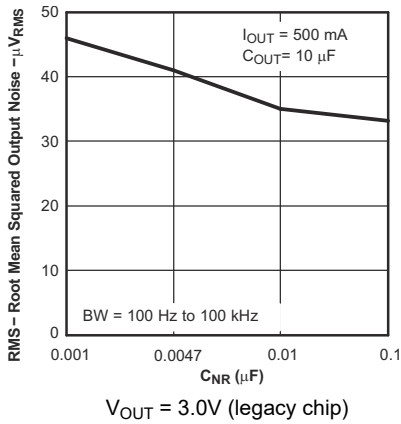

Figure 5-11. TPS795 Root Mean Squared Output Noise vs C_{NR}

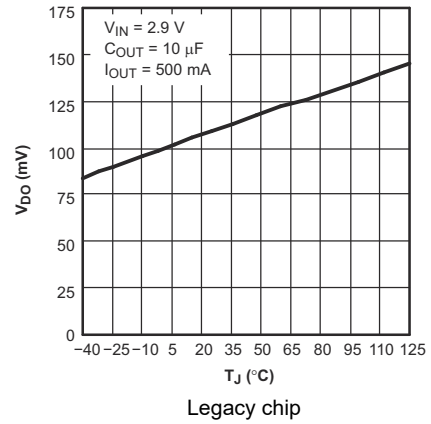

Figure 5-12. TPS795 Dropout Voltage vs Junction Temperature

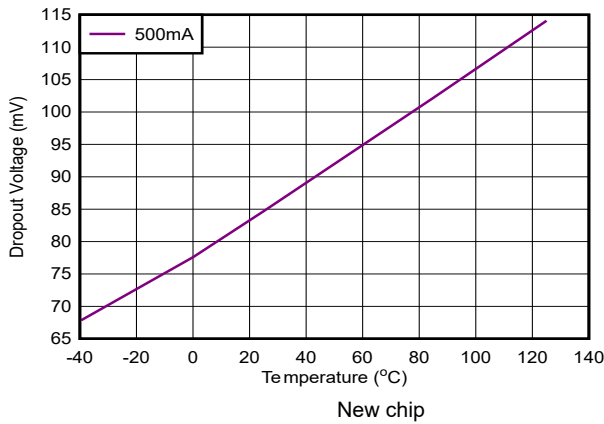

Figure 5-13. TPS795 Dropout Voltage vs Junction Temperature

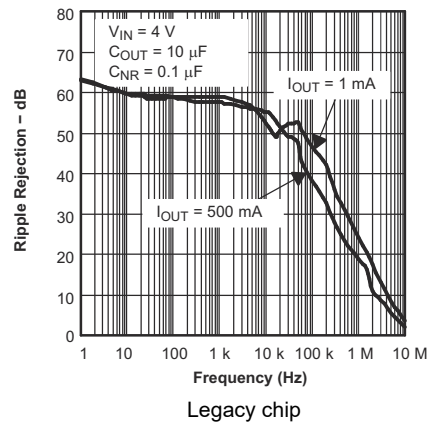

Figure 5-14. TPS795 Ripple Rejection vs Frequency

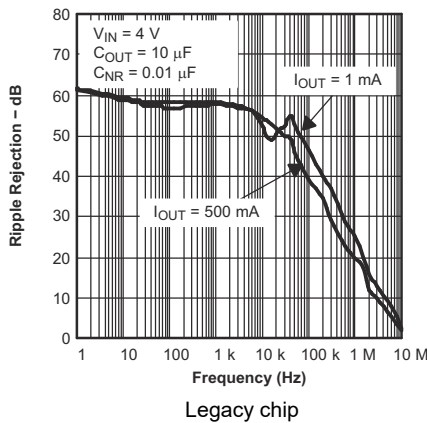

Figure 5-15. TPS795 Ripple Rejection vs Frequency

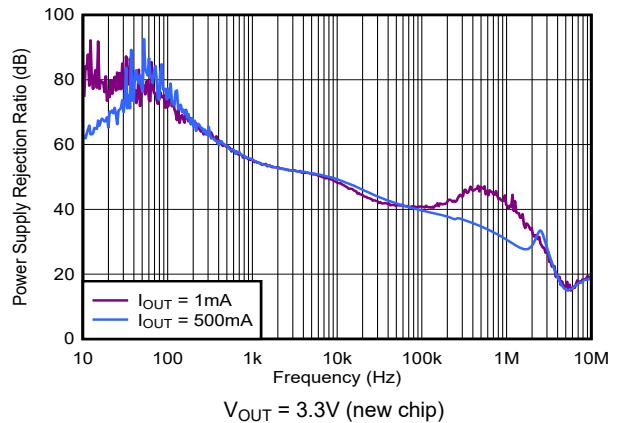

Figure 5-16. TPS795 Ripple Rejection vs Frequency

5.6 Typical Characteristics (continued)

at $V_{EN} = V_{IN}$, $V_{IN} = V_{OUT(nom)} + 1V$, $I_{OUT} = 1mA$, $C_{OUT} = 10 \mu F$, $C_{NR} = 0.01 \mu F$, $C_{IN} = 2.2 \mu F$, and $T_J = 25^\circ C$ (unless otherwise noted)

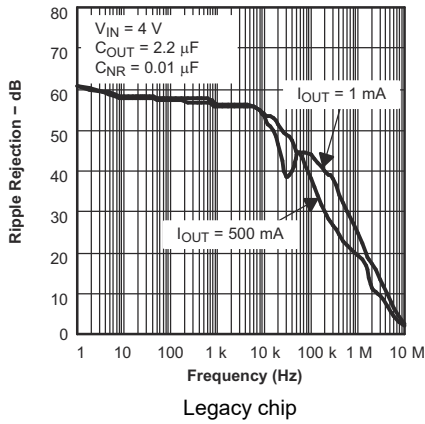

Figure 5-17. TPS795 Ripple Rejection vs Frequency

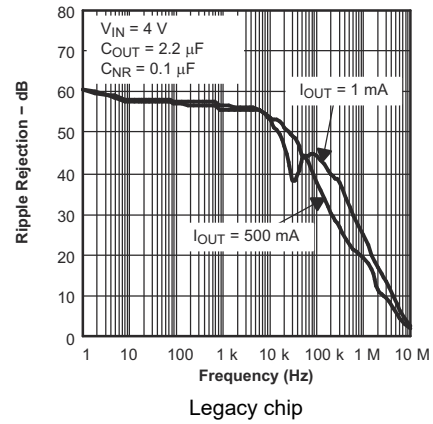

Figure 5-18. TPS795 Ripple Rejection vs Frequency

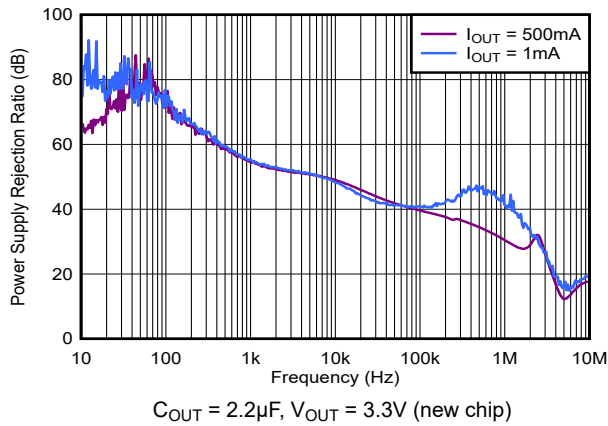

Figure 5-19. TPS795 Ripple Rejection vs Frequency

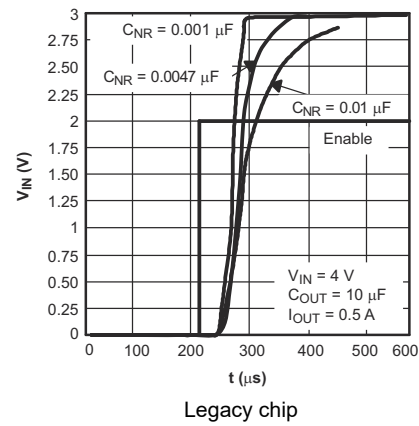

Figure 5-20. TPS795 Start-Up Time

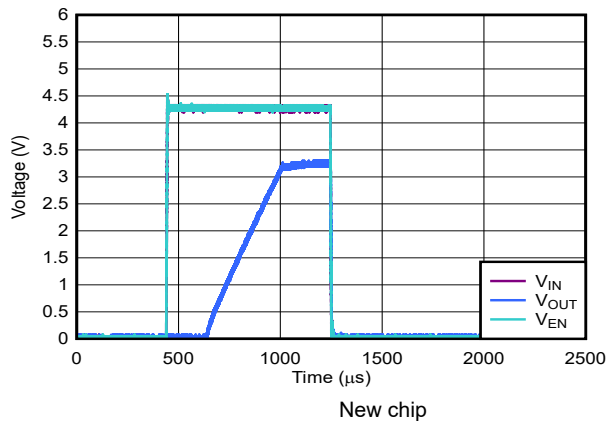

Figure 5-21. TPS795 Start-Up Time

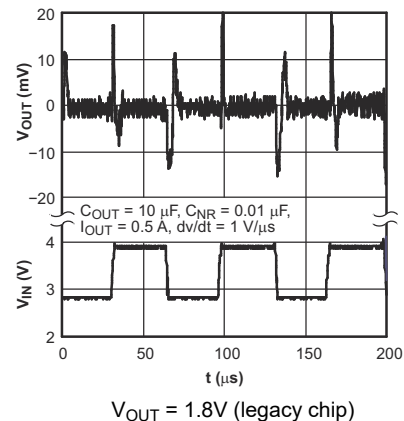

Figure 5-22. TPS795 Line Transient Response

5.6 Typical Characteristics (continued)

at $V_{EN} = V_{IN}$, $V_{IN} = V_{OUT(nom)} + 1V$, $I_{OUT} = 1mA$, $C_{OUT} = 10 \mu F$, $C_{NR} = 0.01 \mu F$, $C_{IN} = 2.2 \mu F$, and $T_J = 25^\circ C$ (unless otherwise noted)

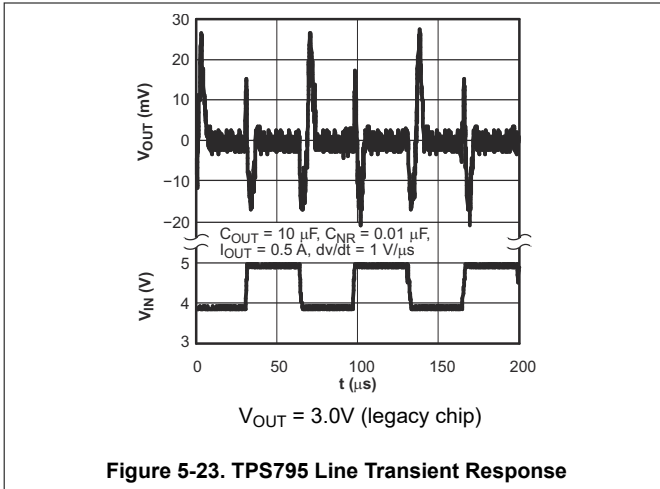

Figure 5-23. TPS795 Line Transient Response

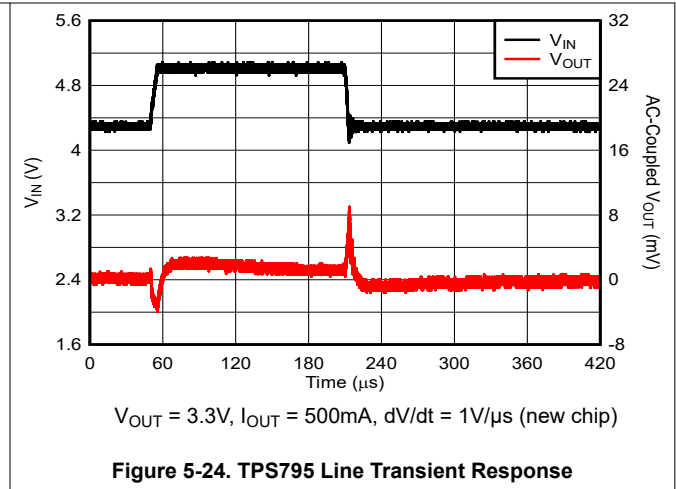

Figure 5-24. TPS795 Line Transient Response

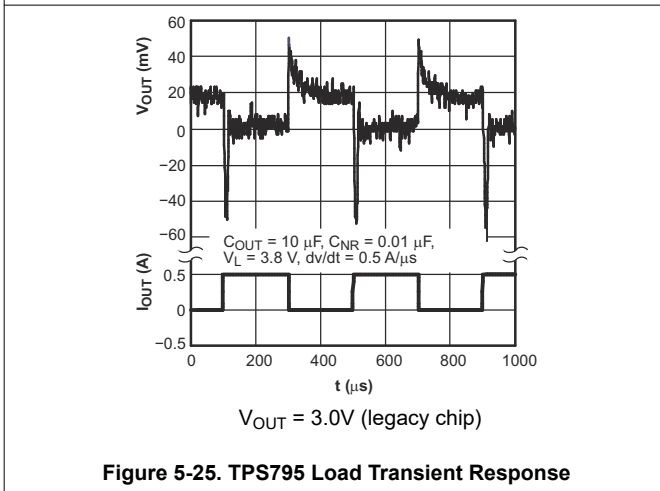

Figure 5-25. TPS795 Load Transient Response

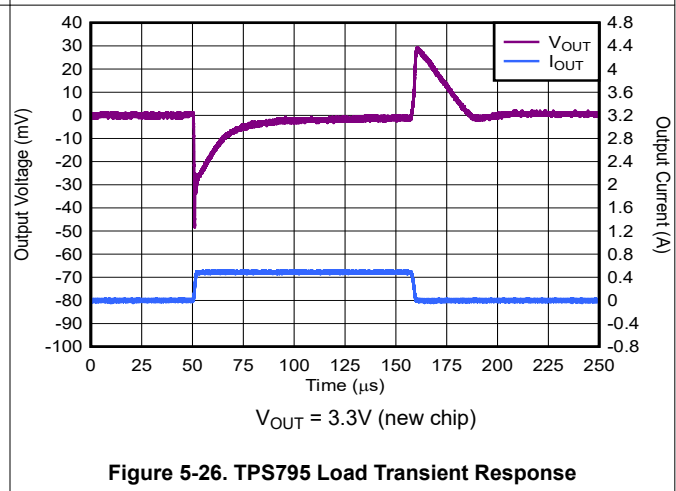

Figure 5-26. TPS795 Load Transient Response

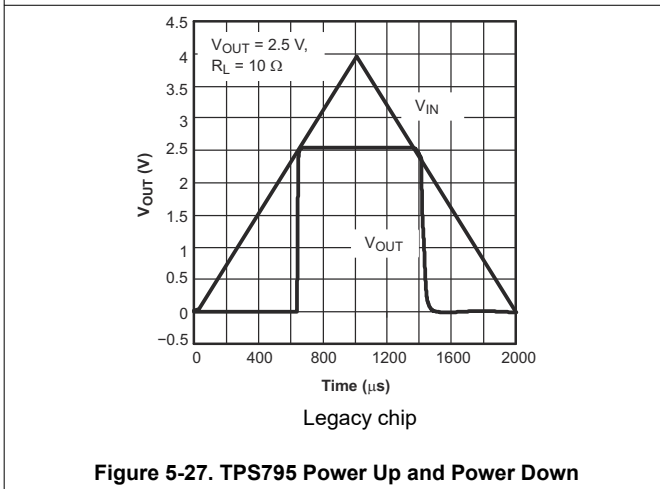

Figure 5-27. TPS795 Power Up and Power Down

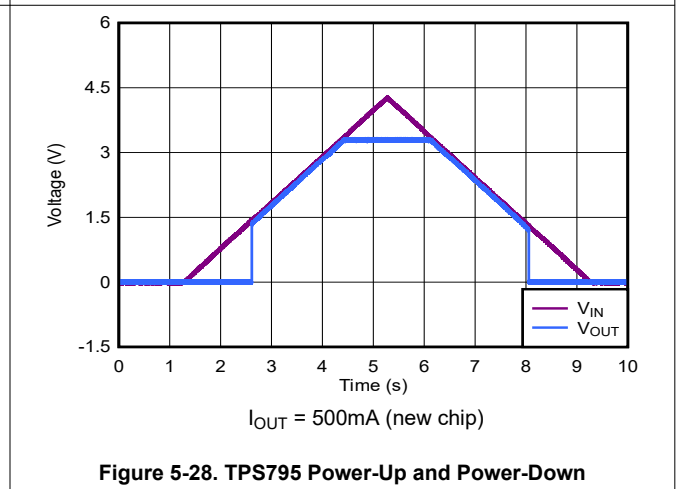

Figure 5-28. TPS795 Power-Up and Power-Down

5.6 Typical Characteristics (continued)

at $V_{EN} = V_{IN}$, $V_{IN} = V_{OUT(nom)} + 1V$, $I_{OUT} = 1mA$, $C_{OUT} = 10 \mu F$, $C_{NR} = 0.01 \mu F$, $C_{IN} = 2.2 \mu F$, and $T_J = 25^\circ C$ (unless otherwise noted)

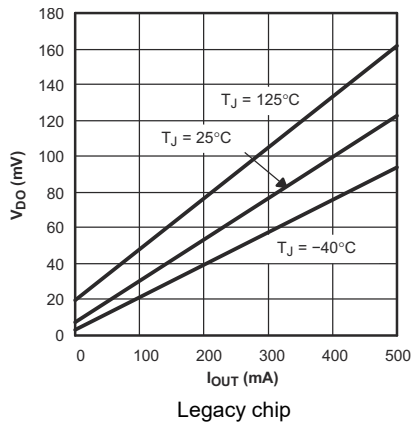

Figure 5-29. TPS795 Dropout Voltage vs Output Current

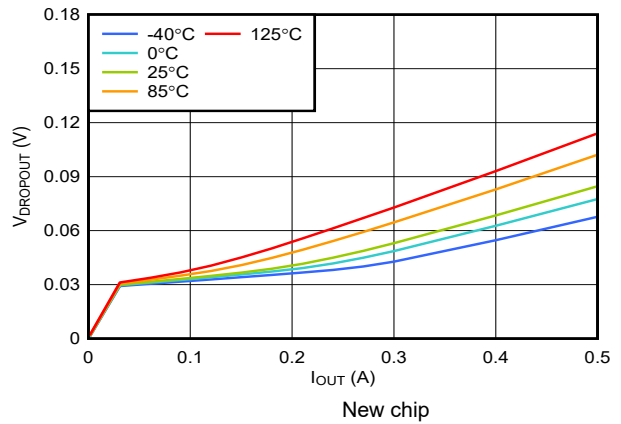

Figure 5-30. TPS795 Dropout Voltage vs Output Current

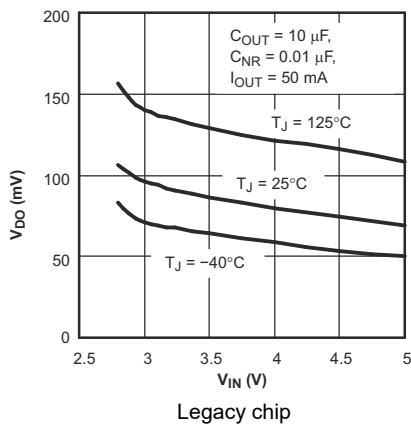

Figure 5-31. TPS795 Dropout Voltage vs Input Voltage

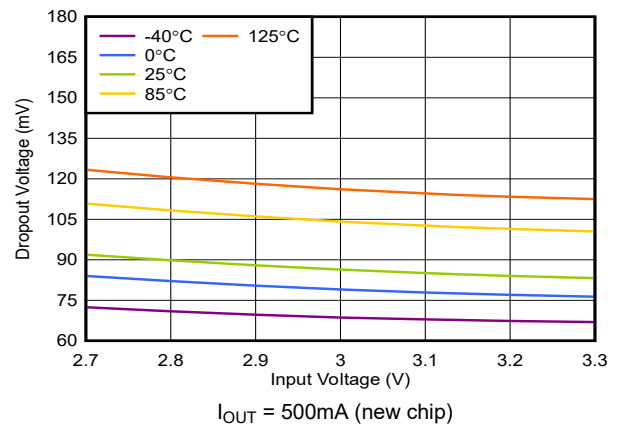

Figure 5-32. TPS795 Dropout Voltage vs Input Voltage

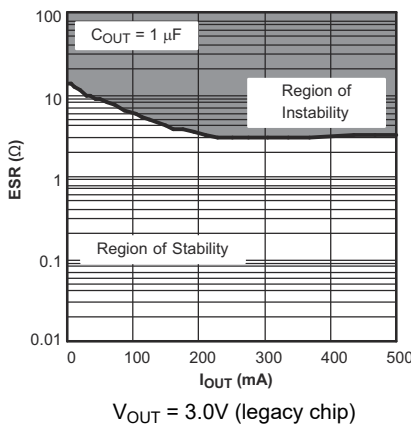

Figure 5-33. TPS795 Typical Regions of Stability Equivalent Series Resistance (ESR) vs Output Current

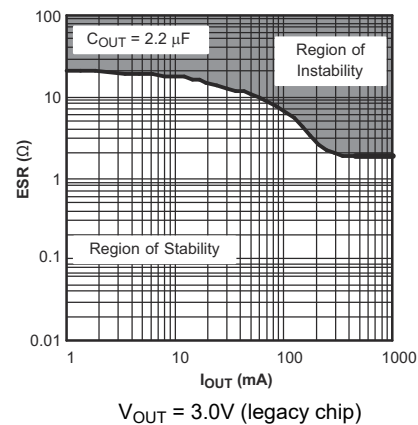

Figure 5-34. TPS795 Typical Regions of Stability Equivalent Series Resistance (ESR) vs Output Current

5.6 Typical Characteristics (continued)

at $V_{EN} = V_{IN}$, $V_{IN} = V_{OUT(nom)} + 1V$, $I_{OUT} = 1mA$, $C_{OUT} = 10 \mu F$, $C_{NR} = 0.01 \mu F$, $C_{IN} = 2.2 \mu F$, and $T_J = 25^\circ C$ (unless otherwise noted)

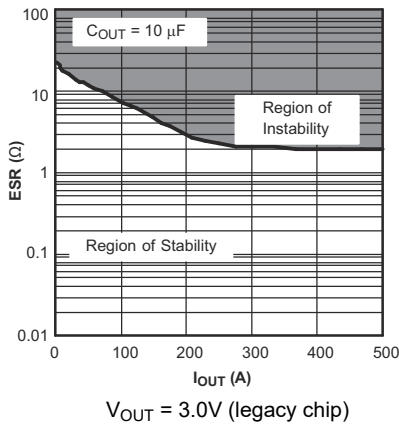

Figure 5-35. TPS795 Typical Regions of Stability Equivalent Series Resistance (ESR) vs Output Current

6 Detailed Description

6.1 Overview

The TPS795 combines the high performance required of many RF and precision analog applications with low current consumption. High PSRR is provided by a high-gain, high-bandwidth error loop with good supply rejection at very low headroom ($V_{IN} - V_{OUT}$). This regulator offers current limit protection, output enable, active discharge, undervoltage lockout (UVLO), and thermal protection.

6.2 Functional Block Diagrams

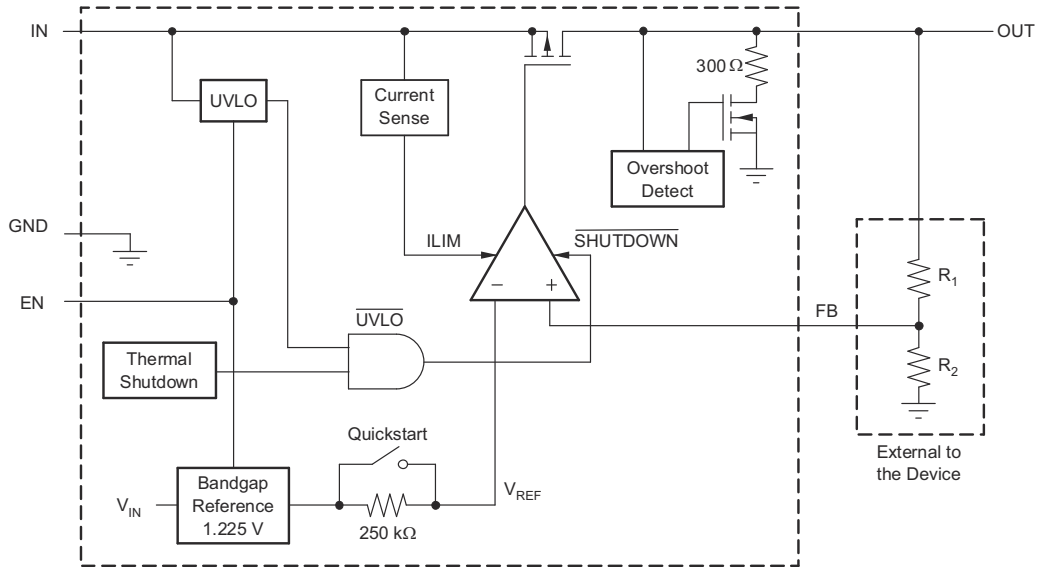

Figure 6-1. Functional Block Diagram (Adjustable Version, Legacy Chip)

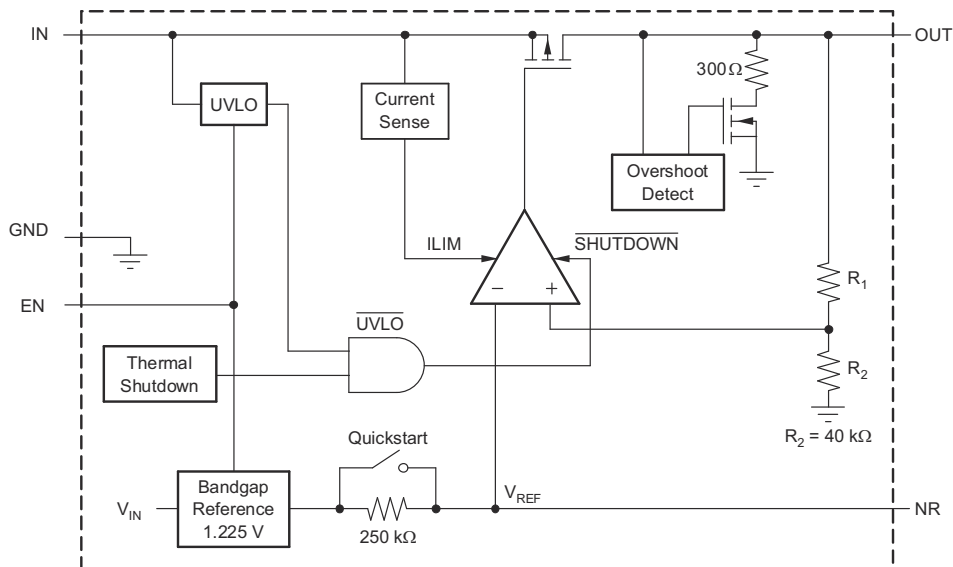

Figure 6-2. Functional Block Diagram (Fixed Versions, Legacy Chip)

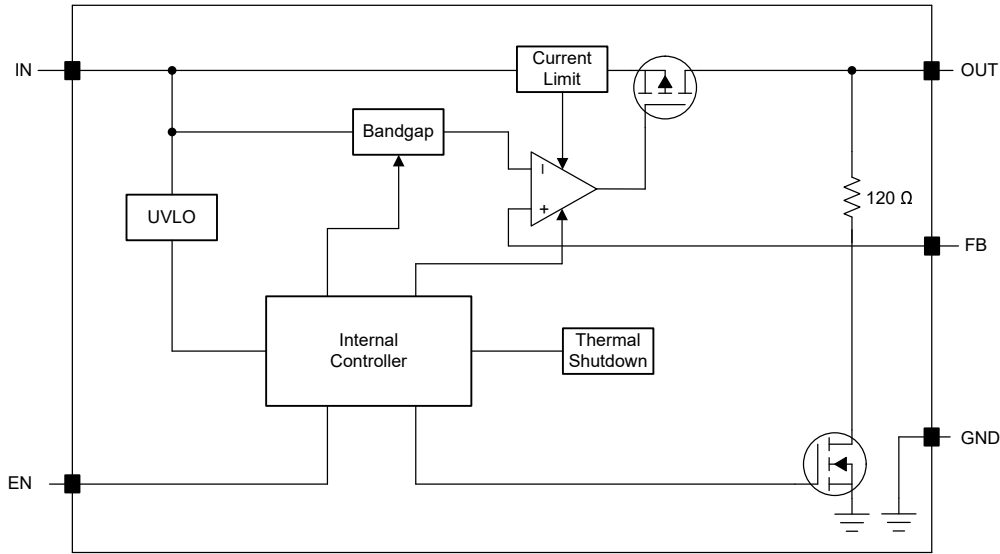

Figure 6-3. Functional Block Diagram (Adjustable Version, New Chip)

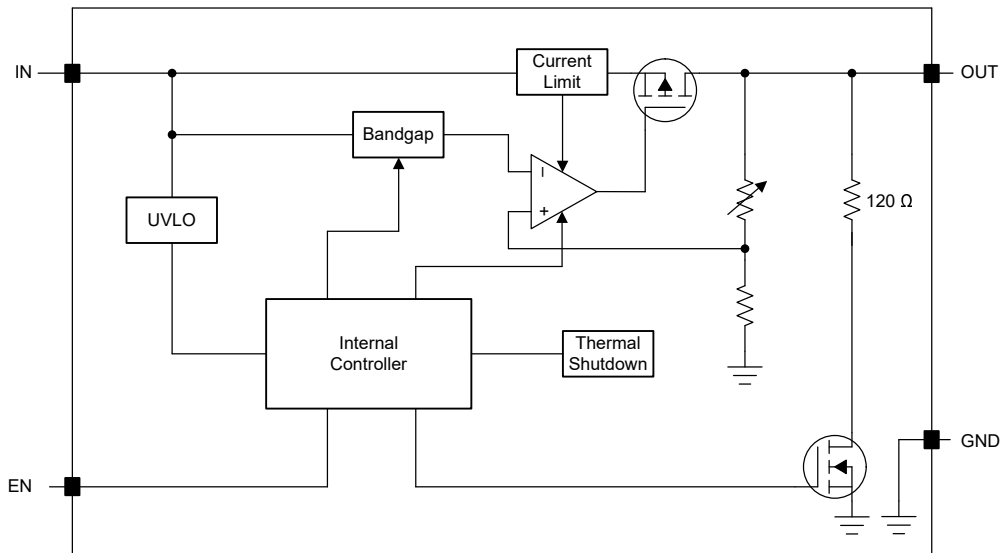

Figure 6-4. Functional Block Diagram (Fixed Versions, New Chip)

6.3 Feature Description

6.3.1 Shutdown

The enable pin (EN) is active high and is compatible with standard and low-voltage TTL-CMOS levels. When shutdown capability is not required, EN can be connected to IN.

6.3.2 Start-Up

The TPS795 uses a start-up circuit to quickly charge the noise reduction capacitor, C_{NR} , if present (see [Section 6.2](#)). This circuit allows for the combination of very low output noise and fast start-up times. The NR pin is high impedance so a low leakage C_{NR} capacitor must be used; most ceramic capacitors are appropriate for this configuration.

For the fastest start-up, apply V_{IN} first, and then drive the enable pin (EN) high. If EN is tied to IN, start-up is somewhat slower. To verify that C_{NR} is fully charged during start-up, use a 0.1 μF or smaller capacitor.

6.3.3 Undervoltage Lockout (UVLO)

The TPS795 uses an undervoltage lockout circuit to keep the output shut off until internal circuitry is operating properly. The UVLO circuit has approximately 100mV of hysteresis to help reject input voltage drops when the regulator first turns on.

6.3.4 Regulator Protection

The TPS795 (legacy chip) PMOS-pass transistor has a built-in back diode that conducts reverse current when the input voltage drops below the output voltage (for example, during power down). Current is conducted from the output to the input and is not internally limited. If extended reverse voltage operation is anticipated, external limiting is sometimes appropriate.

During normal operation, the TPS795 (legacy chip) limits output current to approximately 2.8A. When current limiting engages, the output voltage scales back linearly until the overcurrent condition ends. While current limiting is designed to prevent gross device failure, care must be taken not to exceed the power dissipation ratings of the package

For the new chip, the device has an internal current limit circuit that protects the regulator during transient high-load current faults or shorting events. The current limit is a hybrid brick-wall-foldback scheme. The current limit transitions from a brick-wall scheme to a foldback scheme at the foldback voltage ($V_{FOLDBACK}$). In a high-load current fault with the output voltage above $V_{FOLDBACK}$, the brick-wall scheme limits the output current to the current limit (I_{CL}). When the voltage drops below $V_{FOLDBACK}$, a foldback current limit activates that scales back the current as the output voltage approaches GND. When the output is shorted, the device supplies a typical current called the short-circuit current limit (I_{SC}). I_{CL} and I_{SC} are listed in the *Electrical Characteristics* table.

For this device, $V_{FOLDBACK} = 0.4 \times V_{OUT(NOM)}$.

The output voltage is not regulated when the device is in current limit. When a current limit event occurs, the device begins to heat up because of the increase in power dissipation. When the device is in brick-wall current limit, the pass transistor dissipates power $[(V_{IN} - V_{OUT}) \times I_{CL}]$. When the device output is shorted and the output is below $V_{FOLDBACK}$, the pass transistor dissipates power $[(V_{IN} - V_{OUT}) \times I_{SC}]$. If thermal shutdown is triggered, the device turns off. After the device cools down, the internal thermal shutdown circuit turns the device back on. If the output current fault condition continues, the device cycles between current limit and thermal shutdown. For more information on current limits, see the [Know Your Limits application note](#).

Figure 6-5 shows a diagram of the foldback current limit.

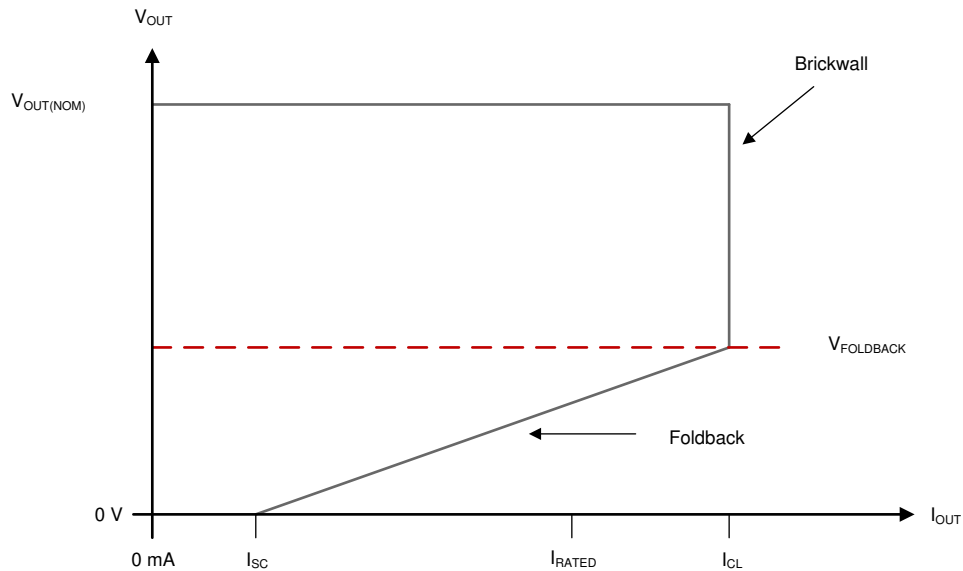

Figure 6-5. Foldback Current Limit

6.3.5 Thermal Shutdown

The device contains a thermal shutdown protection circuit to disable the device when the junction temperature (T_J) of the pass transistor rises to $T_{SD(\text{shutdown})}$ (typical). Thermal shutdown hysteresis verifies that the device resets (turns on) when the temperature falls to $T_{SD(\text{reset})}$ (typical).

The thermal time-constant of the semiconductor die is fairly short, thus the device can cycle on and off when thermal shutdown is reached until power dissipation is reduced. Power dissipation during startup can be high from large $V_{IN} - V_{OUT}$ voltage drops across the device or from high inrush currents charging large output capacitors. Under some conditions, the thermal shutdown protection disables the device before startup completes.

For reliable operation, limit the junction temperature to the maximum listed in the *Recommended Operating Conditions* table. Operation above this maximum temperature causes the device to exceed the operational specifications. Although the internal protection circuitry of the device is designed to protect against thermal overall conditions, this circuitry is not intended to replace proper heat sinking. Continuously running the device into thermal shutdown or above the maximum recommended junction temperature reduces long-term reliability.

6.4 Device Functional Modes

Table 6-1 provides a quick comparison between the normal, dropout, and disabled modes of operation.

Table 6-1. Device Functional Mode Comparison

OPERATING MODE	PARAMETER			
	V_{IN}	EN	I_{OUT}	T_J
Normal	$V_{IN} > V_{OUT(nom)} + V_{DO}$	$V_{EN} > V_{EN(HI)}$	$I_{OUT} < I_{CL}$	$T_J < T_{sd}$
Dropout	$V_{IN} < V_{OUT(nom)} + V_{DO}$	$V_{EN} > V_{EN(HI)}$	$I_{OUT} < I_{CL}$	$T_J < T_{sd}$
Disabled	—	$V_{EN} < V_{EN(LO)}$	—	$T_J > T_{sd}$

6.4.1 Normal Operation

The device regulates to the nominal output voltage under the following conditions:

- The input voltage is greater than the nominal output voltage plus the dropout voltage ($V_{OUT(nom)} + V_{DO}$).
- The enable voltage has previously exceeded the enable rising threshold voltage and not yet decreased below the enable falling threshold.
- The output current is less than the current limit ($I_{OUT} < I_{CL}$).
- The device junction temperature is less than the thermal shutdown temperature ($T_J < T_{sd}$).

6.4.2 Dropout Operation

If the input voltage is lower than the nominal output voltage plus the specified dropout voltage, but all other conditions are met for normal operation, the device operates in dropout mode. In this mode, the output voltage tracks the input voltage. During this mode, the transient performance of the device becomes significantly degraded because the pass transistor is in the linear region and no longer controls the current through the LDO. Line or load transients in dropout can result in large output voltage deviations.

6.4.3 Disabled

The device is disabled under the following conditions:

- The enable voltage is less than the enable falling threshold voltage or has not yet exceeded the enable rising threshold.
- The device junction temperature is greater than the thermal shutdown temperature ($T_J > T_{sd}$).

7 Application and Implementation

Note

Information in the following applications sections is not part of the TI component specification, and TI does not warrant its accuracy or completeness. TI's customers are responsible for determining suitability of components for their purposes, as well as validating and testing their design implementation to confirm system functionality.

7.1 Application Information

The TPS795 LDO is optimized for use in noise-sensitive applications. The device features extremely low dropout voltages, high PSRR, low output noise, low quiescent current, and an enable input to reduce supply currents when the regulator is turned off.

7.2 Typical Application

A typical application circuit is shown in [Figure 7-1](#).

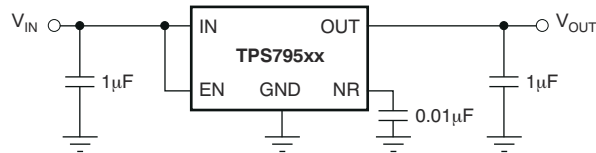

Figure 7-1. Typical Application Circuit

7.2.1 Design Requirements

[Table 7-1](#) lists the design requirements.

Table 7-1. Design Parameters

PARAMETER	DESIGN REQUIREMENT
Input voltage	3.3V
Output voltage	2.5V
Maximum output current	500mA

7.2.2 Detailed Design Procedure

Select the desired device based on the output voltage.

Provide an input supply with adequate headroom to account for dropout and output current to account for the GND pin current, and power the load.

7.2.2.1 Input and Output Capacitor Requirements

The TPS795 (legacy chip) does not require an input capacitor, however, good analog design practice is to place a 0.1µF to 2.2µF capacitor near the input of the regulator to counteract reactive input sources. The TPS795 (new chip) requires an input capacitor of 1µF at the input. A higher-value input capacitor can be necessary if large, fast-rise time load transients are anticipated and the device is located several inches from the power source.

Like most low dropout regulators, the TPS795 requires an output capacitor connected between OUT and GND to stabilize the internal control loop. The minimum recommended capacitor is 1µF. Any 1µF or larger ceramic capacitor is suitable. Dynamic performance of the device is improved by using a higher capacitor than the minimum output capacitor.

7.2.2.2 Load Transient Response

The load-step transient response is the output voltage response by the LDO to a step in load current, whereby output voltage regulation is maintained. There are two key transitions during a load transient response: the

transition from a light to a heavy load and the transition from a heavy to a light load. The regions shown in [Figure 7-2](#) are broken down as follows. Regions A, E, and H are where the output voltage is in steady-state.

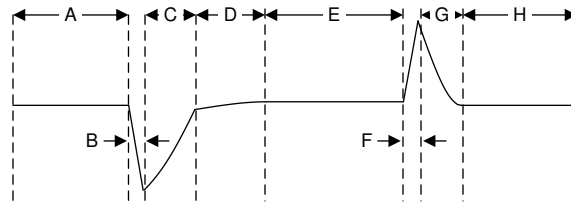

Figure 7-2. Load Transient Waveform

During transitions from a light load to a heavy load, the:

- Initial voltage dip is a result of the depletion of the output capacitor charge and parasitic impedance to the output capacitor (region B)
- Recovery from the dip results from the LDO increasing the sourcing current, and leads to output voltage regulation (region C)
- Initial voltage rise results from the LDO sourcing a large current, and leads to the output capacitor charge to increase (region F)
- Recovery from the rise results from the LDO decreasing the sourcing current in combination with the load discharging the output capacitor (region G)

A larger output capacitance reduces the peaks during a load transient but slows down the response time of the device. A larger DC load also reduces the peaks because the amplitude of the transition is lowered and a higher current discharge path is provided for the output capacitor.

7.2.2.3 Output Noise

The internal voltage reference is a key source of noise in an LDO regulator. The TPS795 (legacy chip) has an NR pin connected to the voltage reference through a 250kΩ internal resistor. The 250kΩ internal resistor, in conjunction with an external bypass capacitor connected to the NR pin, creates a low-pass filter to reduce the voltage reference noise and, therefore, the noise at the regulator output. For the regulator to operate properly, the current flow out of the NR pin must be at a minimum, because any leakage current creates an IR drop across the internal resistor, thus creating an output error. Therefore, the bypass capacitor must have minimal leakage current. The bypass capacitor must be no more than 0.1μF to make sure the capacitor is fully charged during the quick-start time provided by the internal switch given in the [Functional Block Diagrams](#) section.

7.2.2.4 Dropout Voltage

The TPS795 uses a PMOS-pass transistor to achieve a low dropout voltage. When $(V_{IN} - V_{OUT})$ is less than the dropout voltage (V_{DO}), the PMOS-pass transistor is in the linear region of operation and $r_{DS(on)}$ of the PMOS-pass transistor is the input-to-output resistance. Because the PMOS transistor behaves like a resistor in dropout, V_{DO} approximately scales with the output current.

As with any linear regulator, PSRR degrades as $(V_{IN} - V_{OUT})$ approaches dropout. This effect is illustrated in [Figure 5-14](#) through [Figure 5-18](#).

7.2.2.5 Programming the TPS79501 Adjustable LDO Regulator

The output voltage of the TPS79501 adjustable regulator is programmed using an external resistor divider as shown in [Figure 7-3](#).

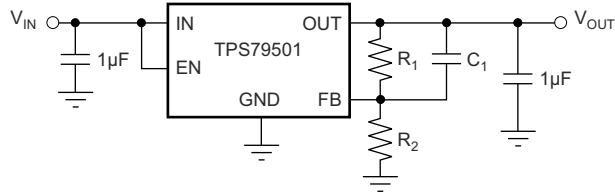

OUTPUT VOLTAGE
PROGRAMMING GUIDE

OUTPUT VOLTAGE	R ₁	R ₂	C ₁
1.8 V	14.0 kΩ	30.1 kΩ	33 pF
3.6 V	57.9 kΩ	30.1 kΩ	15 pF

Figure 7-3. Typical Application, Adjustable Output

The output voltage is calculated using [Equation 1](#).

$$V_{OUT} = V_{REF} \times \left(1 + \frac{R_1}{R_2} \right) \quad (1)$$

where

- $V_{REF} = 1.2246V$ typical (the internal reference voltage)

Resistors R_1 and R_2 must be selected for approximately 40µA divider current. Lower value resistors can be used for improved noise performance, but the device wastes more power. Higher values must be avoided, as leakage current at FB increases the output voltage error.

The recommended design procedure is to select $R_2 = 30.1\text{k}\Omega$ to set the divider current at $40\mu\text{A}$, $C_1 = 15\text{pF}$ for stability, and then calculate R_1 using [Equation 2](#).

$$R_1 = \left(\frac{V_{\text{OUT}}}{V_{\text{REF}}} - 1 \right) \times R_2 \quad (2)$$

To improve the stability of the adjustable version, TI suggests placing a small compensation capacitor between OUT and FB.

The approximate value of this capacitor can be calculated using [Equation 3](#).

$$C_1 = \frac{(3 \times 10^{-7}) \times (R_1 + R_2)}{(R_1 \times R_2)} \quad (3)$$

The suggested value of this capacitor for several resistor ratios is shown in the table within [Figure 7-3](#). If this capacitor is not used (such as in a unity-gain configuration), then the minimum recommended output capacitor is $2.2\mu\text{F}$ instead of $1\mu\text{F}$.

Similarly, for the TPS795 (new chip), to disregard the effect of the FB pin current error term and to achieve best accuracy, select R_2 to be equal to or smaller than $550\text{k}\Omega$ so that the current flowing through R_1 and R_2 is at least five times larger than the I_{FB} current listed in the *Electrical Characteristics* table. Lowering the value of R_2 increases the immunity against noise injection. Increasing the value of R_2 reduces the quiescent current for achieving higher efficiency at low load currents. [Equation 4](#) calculates the setting that provides the maximum feedback divider series resistance.

$$(R_1 + R_2) \leq V_{\text{OUT}} / (I_{\text{FB}} \times 5) \quad (4)$$

7.2.3 Application Curves

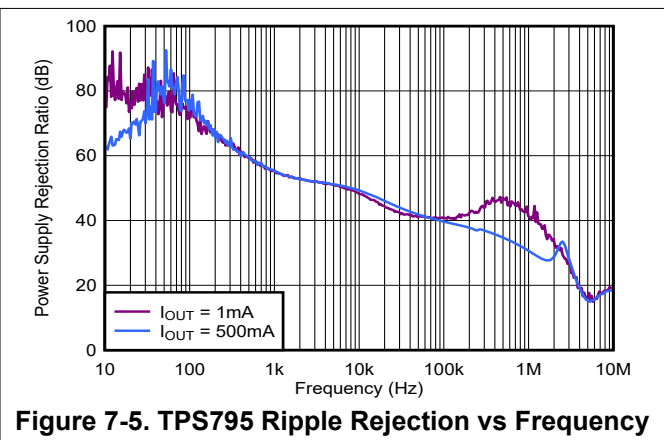
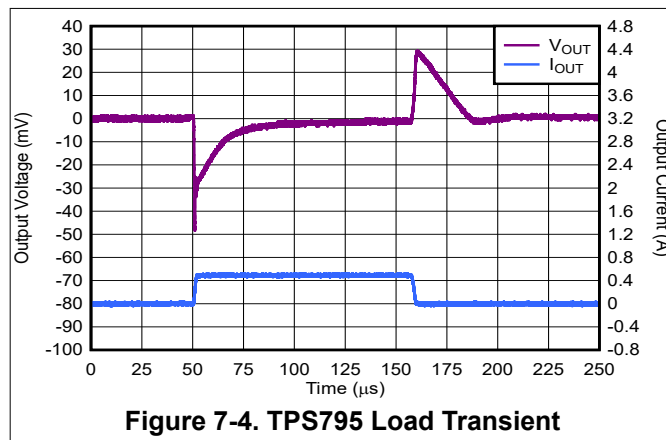

7.3 Best Design Practices

Place at least one $1\text{-}\mu\text{F}$ ceramic capacitor as close as possible to the OUT pin of the regulator.

Do not place the output capacitor more than 10mm away from the regulator.

Connect a $0.1\text{-}\mu\text{F}$ or larger, low equivalent series resistance (ESR) capacitor across the IN pin and GND input of the regulator.

Do not exceed the absolute maximum ratings.

7.4 Power Supply Recommendations

These devices are designed to operate from an input voltage supply range from 2.7V to 5.5V. The input voltage range provides adequate headroom for the device to have a regulated output. This input supply is well-regulated and stable. If the input supply is noisy, additional input capacitors with low ESR can help improve the output noise performance.

7.5 Layout

7.5.1 Layout Guidelines

7.5.1.1 Board Layout Recommendation to Improve PSRR and Noise Performance

To improve ac measurements like PSRR, output noise, and transient response, TI recommends designing the board with separate ground planes for V_{IN} and V_{OUT} , with each ground plane connected only at the ground pin of the device. In addition, the ground connection for the bypass capacitor must connect directly to the ground pin of the device.

7.5.1.2 Regulator Mounting

The tab of the 6-pin SOT-223 package is electrically connected to ground. For best thermal performance, solder the tab of the surface-mount version directly to a circuit-board copper area. Increasing the copper area improves heat dissipation.

Solder pad footprint recommendations for the devices are presented in the [Solder Pad Recommendations for Surface-Mount Devices application note](#), available from the TI website (www.ti.com).

7.5.1.3 Thermal Considerations

Knowing the device power dissipation and proper sizing of the thermal plane that is connected to the tab or pad is critical to avoiding thermal shutdown and providing reliable operation.

Power dissipation of the device depends on input voltage and load conditions and can be calculated using [Equation 5](#):

$$P_D = (V_{IN} - V_{OUT}) \times I_{OUT} \quad (5)$$

Power dissipation can be minimized and greater efficiency can be achieved by using the lowest possible input voltage necessary to achieve the required output voltage regulation.

On the VSON (DRB) package, the primary conduction path for heat is through the exposed pad to the printed-circuit-board (PCB). The pad can be connected to ground or be left floating; however, attach the pad to an appropriate amount of copper PCB area to make sure the device does not overheat. On the SOT-223 (DCQ) package, the primary conduction path for heat is through the tab to the PCB. Connect the tab to ground. The maximum junction-to-ambient thermal resistance depends on the maximum ambient temperature, maximum device junction temperature, and power dissipation of the device and can be calculated using [Equation 6](#):

$$R_{\theta JA} = \frac{(+125^{\circ}\text{C} - T_A)}{P_D} \quad (6)$$

Knowing the maximum $R_{\theta_{JA}}$, the minimum amount of PCB copper area needed for appropriate heatsinking can be estimated using [Figure 7-6](#).

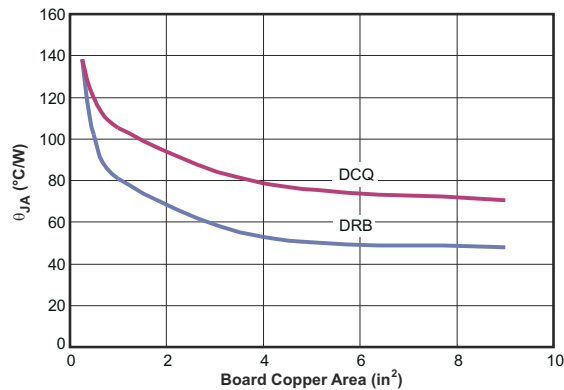

θ_{JA} value at board size of 9 in.² (that is, 3 in. × 3 in.) is a JEDEC standard.

Figure 7-6. θ_{JA} vs Board Size

[Figure 7-6](#) shows the variation of θ_{JA} as a function of ground plane copper area in the board. This figure is intended only as a guideline to demonstrate the effect of heat spreading in the ground plane and is not intended to estimate the thermal performance in real application environments.

Note

When the device is mounted on an application PCB, use Ψ_{JT} and Ψ_{JB} , as explained in [Section 7.5.1.4](#).

7.5.1.4 Estimating Junction Temperature

Using the thermal metrics Ψ_{JT} and Ψ_{JB} , as shown in [Thermal Information](#), the junction temperature can be estimated with corresponding formulas (given in [Equation 7](#)). For backwards compatibility, an older $\theta_{JC, Top}$ parameter is also listed.

$$\Psi_{JT}: T_J = T_T + \Psi_{JT} \cdot P_D$$

$$\Psi_{JB}: T_J = T_B + \Psi_{JB} \cdot P_D \tag{7}$$

where

- P_D is the power dissipation shown by [Equation 6](#)
- T_T is the temperature at the center-top of the device package
- T_B is the PCB temperature measured 1 mm away from the device package *on the PCB surface* (see [Figure 7-8](#))

Note

Both T_T and T_B can be measured on actual application boards using a thermo-gun (an infrared thermometer).

For more information about measuring T_T and T_B , see the [Using New Thermal Metrics application note](#), available for download at www.ti.com.

As shown in Figure 7-7, the new thermal metrics (Ψ_{JT} and Ψ_{JB}) have little dependency on board size. That is, using Ψ_{JT} or Ψ_{JB} with Equation 7 is a good way to estimate T_J by simply measuring T_T or T_B , regardless of the application board size.

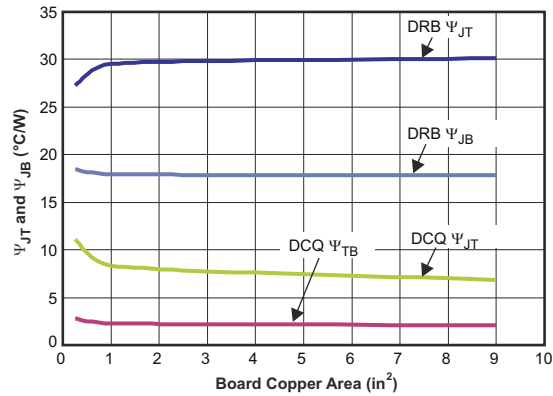

Figure 7-7. Ψ_{JT} and Ψ_{JB} vs Board Size

For a more detailed discussion of why TI does not recommend using $\theta_{JC(top)}$ to determine thermal characteristics, see the *Using New Thermal Metrics* application note, available at www.ti.com.

For further information, see the *IC Package Thermal Metrics* application note, also available on the TI website.

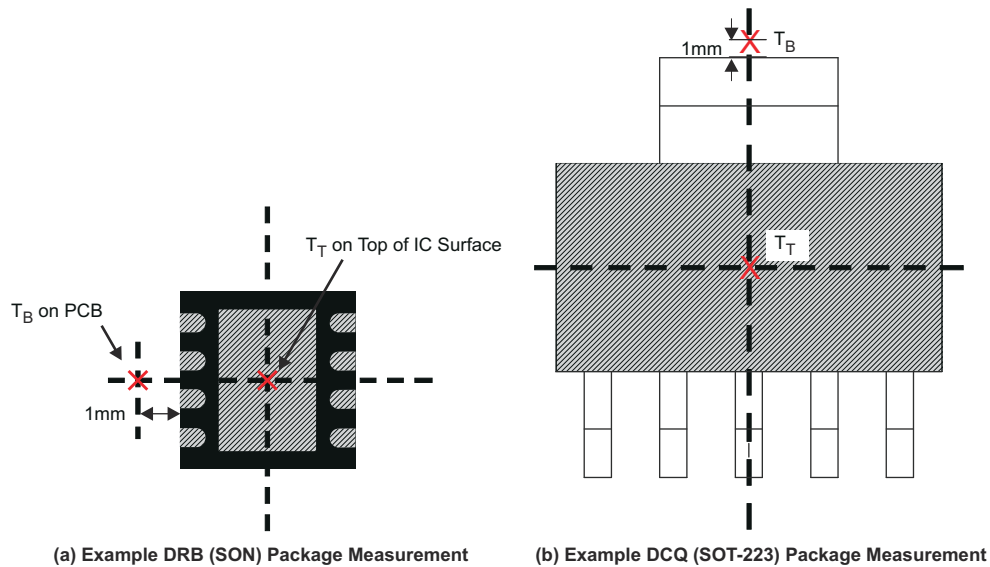

Figure 7-8. Measuring Point for T_T and T_B

7.5.2 Layout Examples

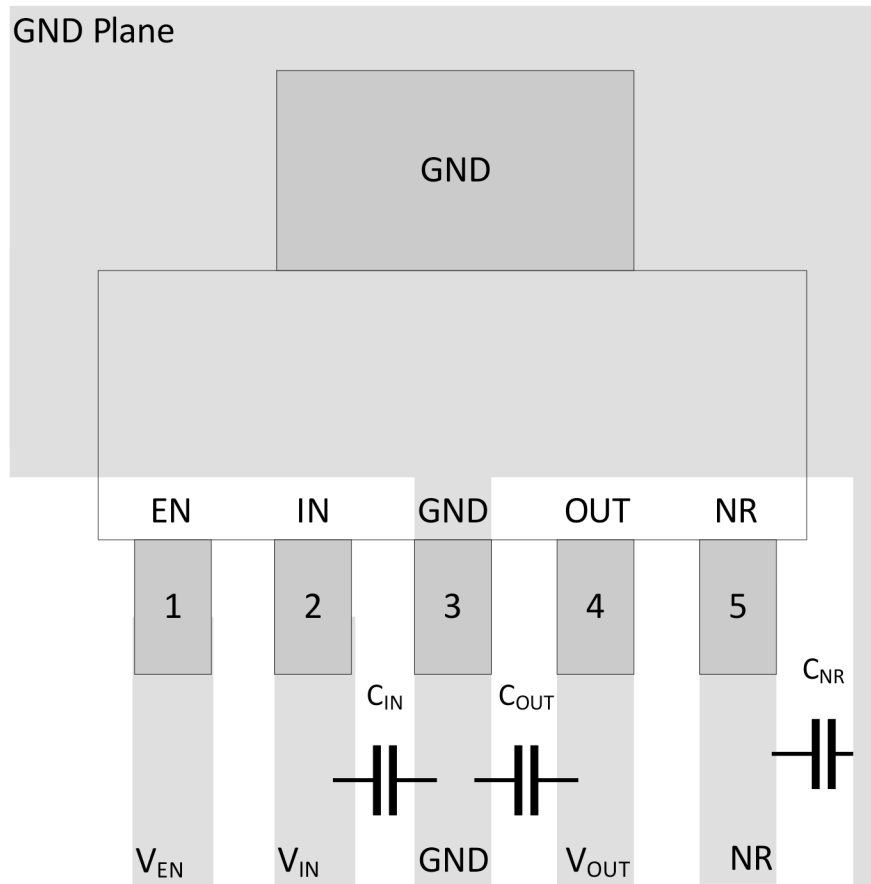

Figure 7-9. TPS795 DCQ Layout Example (Legacy Chip)

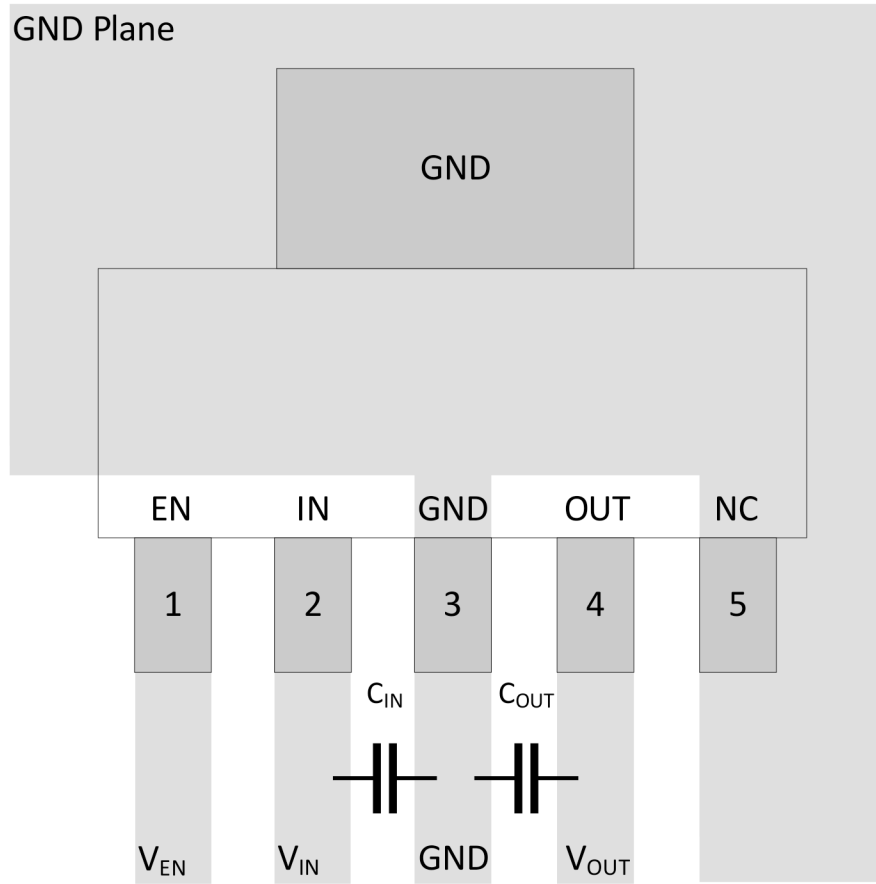

Figure 7-10. TPS795 DCQ Layout Example (New Chip)

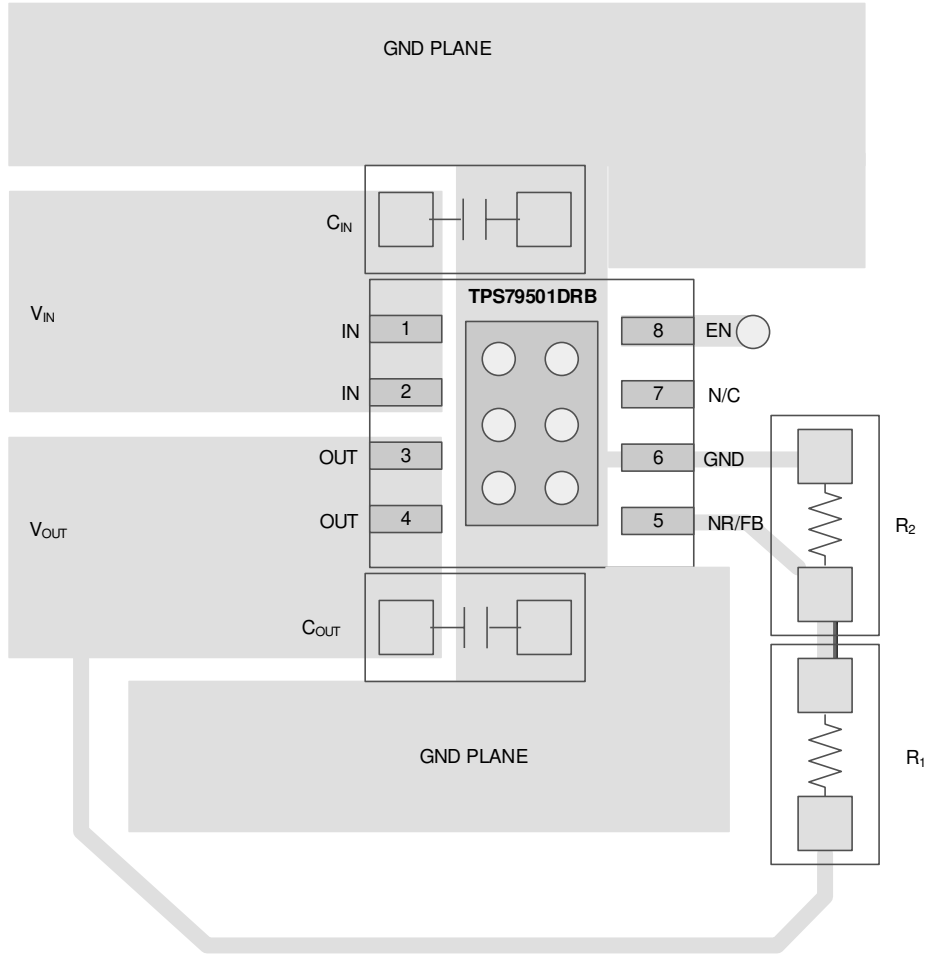

Figure 7-11. TPS795 DRB Layout Example

8 Device and Documentation Support

8.1 Device Support

8.1.1 Development Support

8.1.1.1 Evaluation Modules

An evaluation module (EVM) is available to assist in the initial circuit performance evaluation using the TPS795. The [TPS79501DRBEVM evaluation module](#) related (and [user's guide](#)) can be requested at the TI website through the product folders or purchased [directly from the TI eStore](#).

8.1.1.2 Spice Models

Computer simulation of circuit performance using SPICE is often useful when analyzing the performance of analog circuits and systems. A SPICE model for the TPS795 is available through the product folders under *Tools & Software*.

8.1.2 Device Nomenclature

Table 8-1. Available Options

PRODUCT ⁽¹⁾	DESCRIPTION
TPS795xx(x)yyy zM3	<p>xx(x) is the nominal output voltage (for example, 28 = 2.8V, 285 = 2.85V, 01 = adjustable).</p> <p>yyy is the package designator.</p> <p>z is the package quantity. M3 is a suffix designator for the devices that only use the latest manufacturing flow (CSO:RFB). Devices without this suffix ship with the legacy chip (CSO:DLN) or the new chip (CSO:RFB). The reel packaging label provides CSO information to distinguish which chip is used.</p>

(1) For the most current package and ordering information see the Package Option Addendum at the end of this document, or visit the device product folder at www.ti.com.

8.2 Documentation Support

8.2.1 Related Documentation

- Texas Instruments, [Using New Thermal Metrics application note](#)
- Texas Instruments, [IC Package Thermal Metrics application note](#)
- Texas Instruments, [TPS78601/TPS79501/TPS79601DRB Evaluation Module user's guide](#)
- Texas Instruments, [Using New Thermal Metrics application note](#)

8.3 Receiving Notification of Documentation Updates

To receive notification of documentation updates, navigate to the device product folder on ti.com. Click on *Notifications* to register and receive a weekly digest of any product information that has changed. For change details, review the revision history included in any revised document.

8.4 Support Resources

[TI E2E™ support forums](#) are an engineer's go-to source for fast, verified answers and design help — straight from the experts. Search existing answers or ask your own question to get the quick design help you need.

Linked content is provided "AS IS" by the respective contributors. They do not constitute TI specifications and do not necessarily reflect TI's views; see TI's [Terms of Use](#).

8.5 Trademarks

TI E2E™ is a trademark of Texas Instruments.
All trademarks are the property of their respective owners.

8.6 Electrostatic Discharge Caution



This integrated circuit can be damaged by ESD. Texas Instruments recommends that all integrated circuits be handled with appropriate precautions. Failure to observe proper handling and installation procedures can cause damage.

ESD damage can range from subtle performance degradation to complete device failure. Precision integrated circuits may be more susceptible to damage because very small parametric changes could cause the device not to meet its published specifications.

8.7 Glossary

[TI Glossary](#) This glossary lists and explains terms, acronyms, and definitions.

9 Revision History

NOTE: Page numbers for previous revisions may differ from page numbers in the current version.

Changes from Revision K (June 2025) to Revision L (January 2026)	Page
• added DRB package information for "new chip".....	5

Changes from Revision J (May 2019) to Revision K (June 2025)	Page
• Updated the numbering format for tables, figures, and cross-references throughout the document.....	1
• Added new silicon (M3) devices to document.....	1
• Added nomenclature distinguishing between new chip and legacy chip information throughout document.....	1
• Added portfolio device bullet to <i>Features</i> section.....	1
• Changed <i>Applications</i> section.....	1
• Changed <i>Description</i> section.....	1
• Changed <i>Pin Configuration and Functions</i> section.....	3
• Added new silicon curves to <i>Typical Characteristics</i> section.....	7
• Changed <i>Overview</i> section.....	14
• Added new chip diagrams to <i>Functional Block Diagrams</i> section.....	14
• Changed <i>Application Information</i> section.....	19
• Changed <i>Input and Output Capacitor Requirements</i> section.....	19
• Changed <i>Output Noise</i> section.....	20
• Changed <i>Application Curves</i> section.....	22
• Changed <i>Layout Examples</i> section.....	26
• Added <i>Device Nomenclature</i> section.....	29

10 Mechanical, Packaging, and Orderable Information

The following pages include mechanical, packaging, and orderable information. This information is the most current data available for the designated devices. This data is subject to change without notice and revision of this document. For browser-based versions of this data sheet, refer to the left-hand navigation.

PACKAGING INFORMATION

Orderable part number	Status (1)	Material type (2)	Package Pins	Package qty Carrier	RoHS (3)	Lead finish/ Ball material (4)	MSL rating/ Peak reflow (5)	Op temp (°C)	Part marking (6)
TPS79501DCQ	Active	Production	SOT-223 (DCQ) 6	78 TUBE	Yes	SN	Level-2-260C-1 YEAR	-40 to 125	PS79501
TPS79501DCQ.A	Active	Production	SOT-223 (DCQ) 6	78 TUBE	Yes	SN	Level-2-260C-1 YEAR	-40 to 125	PS79501
TPS79501DCQG4	Active	Production	SOT-223 (DCQ) 6	78 TUBE	Yes	NIPDAU	Level-2-260C-1 YEAR	-40 to 125	PS79501
TPS79501DCQG4.A	Active	Production	SOT-223 (DCQ) 6	78 TUBE	Yes	NIPDAU	Level-2-260C-1 YEAR	-40 to 125	PS79501
TPS79501DCQR	Active	Production	SOT-223 (DCQ) 6	2500 LARGE T&R	Yes	NIPDAU SN	Level-2-260C-1 YEAR	-40 to 125	PS79501
TPS79501DCQR.A	Active	Production	SOT-223 (DCQ) 6	2500 LARGE T&R	Yes	SN	Level-2-260C-1 YEAR	-40 to 125	PS79501
TPS79501DCQRM3	Active	Production	SOT-223 (DCQ) 6	2500 LARGE T&R	Yes	NIPDAU	Level-2-260C-1 YEAR	-40 to 125	PS79501
TPS79501DRBR	Active	Production	SON (DRB) 8	3000 LARGE T&R	Yes	NIPDAU	Level-2-260C-1 YEAR	-40 to 125	BUH
TPS79501DRBR.A	Active	Production	SON (DRB) 8	3000 LARGE T&R	Yes	NIPDAU	Level-2-260C-1 YEAR	-40 to 125	BUH
TPS79501DRBRG4	Active	Production	SON (DRB) 8	3000 LARGE T&R	Yes	NIPDAU	Level-2-260C-1 YEAR	-40 to 125	BUH
TPS79501DRBRG4.A	Active	Production	SON (DRB) 8	3000 LARGE T&R	Yes	NIPDAU	Level-2-260C-1 YEAR	-40 to 125	BUH
TPS79501DRBT	Active	Production	SON (DRB) 8	250 SMALL T&R	Yes	NIPDAU	Level-2-260C-1 YEAR	-40 to 125	BUH
TPS79501DRBT.A	Active	Production	SON (DRB) 8	250 SMALL T&R	Yes	NIPDAU	Level-2-260C-1 YEAR	-40 to 125	BUH
TPS79501DRBTG4	Active	Production	SON (DRB) 8	250 SMALL T&R	Yes	NIPDAU	Level-2-260C-1 YEAR	-40 to 125	BUH
TPS79516DCQ	Obsolete	Production	SOT-223 (DCQ) 6	-	-	Call TI	Call TI	-40 to 125	PS79516
TPS79516DCQR	Active	Production	SOT-223 (DCQ) 6	2500 LARGE T&R	Yes	NIPDAU	Level-2-260C-1 YEAR	-40 to 125	PS79516
TPS79516DCQR.A	Active	Production	SOT-223 (DCQ) 6	2500 LARGE T&R	Yes	NIPDAU	Level-2-260C-1 YEAR	-40 to 125	PS79516
TPS79518DCQ	Obsolete	Production	SOT-223 (DCQ) 6	-	-	Call TI	Call TI	-40 to 125	PS79518
TPS79518DCQR	Active	Production	SOT-223 (DCQ) 6	2500 LARGE T&R	Yes	NIPDAU	Level-2-260C-1 YEAR	-40 to 125	PS79518
TPS79518DCQR.A	Active	Production	SOT-223 (DCQ) 6	2500 LARGE T&R	Yes	NIPDAU	Level-2-260C-1 YEAR	-40 to 125	PS79518
TPS79518DCQRM3	Active	Production	SOT-223 (DCQ) 6	2500 LARGE T&R	Yes	NIPDAU	Level-2-260C-1 YEAR	-40 to 125	PS79518
TPS79525DCQR	Active	Production	SOT-223 (DCQ) 6	2500 LARGE T&R	Yes	NIPDAU	Level-2-260C-1 YEAR	-40 to 125	PS79525
TPS79525DCQR.A	Active	Production	SOT-223 (DCQ) 6	2500 LARGE T&R	Yes	NIPDAU	Level-2-260C-1 YEAR	-40 to 125	PS79525
TPS79525DCQRG4	Active	Production	SOT-223 (DCQ) 6	2500 LARGE T&R	Yes	NIPDAU	Level-2-260C-1 YEAR	-40 to 125	PS79525
TPS79530DCQ	Obsolete	Production	SOT-223 (DCQ) 6	-	-	Call TI	Call TI	-40 to 125	PS79530
TPS79530DCQR	Active	Production	SOT-223 (DCQ) 6	2500 LARGE T&R	Yes	NIPDAU	Level-2-260C-1 YEAR	-40 to 125	PS79530
TPS79530DCQR.A	Active	Production	SOT-223 (DCQ) 6	2500 LARGE T&R	Yes	NIPDAU	Level-2-260C-1 YEAR	-40 to 125	PS79530
TPS79533DCQ	Active	Production	SOT-223 (DCQ) 6	78 TUBE	Yes	SN	Level-2-260C-1 YEAR	-40 to 125	PS79533
TPS79533DCQ.A	Active	Production	SOT-223 (DCQ) 6	78 TUBE	Yes	SN	Level-2-260C-1 YEAR	-40 to 125	PS79533

Orderable part number	Status (1)	Material type (2)	Package Pins	Package qty Carrier	RoHS (3)	Lead finish/ Ball material (4)	MSL rating/ Peak reflow (5)	Op temp (°C)	Part marking (6)
TPS79533DCQG4	Obsolete	Production	SOT-223 (DCQ) 6	-	-	Call TI	Call TI	-40 to 125	PS79533
TPS79533DCQR	Active	Production	SOT-223 (DCQ) 6	2500 LARGE T&R	Yes	NIPDAU SN	Level-2-260C-1 YEAR	-40 to 125	PS79533
TPS79533DCQR.A	Active	Production	SOT-223 (DCQ) 6	2500 LARGE T&R	Yes	SN	Level-2-260C-1 YEAR	-40 to 125	PS79533
TPS79533DCQRG4	Obsolete	Production	SOT-223 (DCQ) 6	-	-	Call TI	Call TI	-40 to 125	PS79533
TPS79533DCQRM3	Active	Production	SOT-223 (DCQ) 6	2500 LARGE T&R	Yes	NIPDAU	Level-2-260C-1 YEAR	-40 to 125	PS79533

(1) **Status:** For more details on status, see our [product life cycle](#).

(2) **Material type:** When designated, preproduction parts are prototypes/experimental devices, and are not yet approved or released for full production. Testing and final process, including without limitation quality assurance, reliability performance testing, and/or process qualification, may not yet be complete, and this item is subject to further changes or possible discontinuation. If available for ordering, purchases will be subject to an additional waiver at checkout, and are intended for early internal evaluation purposes only. These items are sold without warranties of any kind.

(3) **RoHS values:** Yes, No, RoHS Exempt. See the [TI RoHS Statement](#) for additional information and value definition.

(4) **Lead finish/Ball material:** Parts may have multiple material finish options. Finish options are separated by a vertical ruled line. Lead finish/Ball material values may wrap to two lines if the finish value exceeds the maximum column width.

(5) **MSL rating/Peak reflow:** The moisture sensitivity level ratings and peak solder (reflow) temperatures. In the event that a part has multiple moisture sensitivity ratings, only the lowest level per JEDEC standards is shown. Refer to the shipping label for the actual reflow temperature that will be used to mount the part to the printed circuit board.

(6) **Part marking:** There may be an additional marking, which relates to the logo, the lot trace code information, or the environmental category of the part.

Multiple part markings will be inside parentheses. Only one part marking contained in parentheses and separated by a "~" will appear on a part. If a line is indented then it is a continuation of the previous line and the two combined represent the entire part marking for that device.

Important Information and Disclaimer: The information provided on this page represents TI's knowledge and belief as of the date that it is provided. TI bases its knowledge and belief on information provided by third parties, and makes no representation or warranty as to the accuracy of such information. Efforts are underway to better integrate information from third parties. TI has taken and continues to take reasonable steps to provide representative and accurate information but may not have conducted destructive testing or chemical analysis on incoming materials and chemicals. TI and TI suppliers consider certain information to be proprietary, and thus CAS numbers and other limited information may not be available for release.

In no event shall TI's liability arising out of such information exceed the total purchase price of the TI part(s) at issue in this document sold by TI to Customer on an annual basis.

TAPE AND REEL INFORMATION

QUADRANT ASSIGNMENTS FOR PIN 1 ORIENTATION IN TAPE

*All dimensions are nominal

Device	Package Type	Package Drawing	Pins	SPQ	Reel Diameter (mm)	Reel Width W1 (mm)	A0 (mm)	B0 (mm)	K0 (mm)	P1 (mm)	W (mm)	Pin1 Quadrant
TPS79501DCQR	SOT-223	DCQ	6	2500	330.0	12.4	6.85	7.3	1.88	8.0	12.0	Q3
TPS79501DCQRM3	SOT-223	DCQ	6	2500	330.0	12.4	7.05	7.4	1.9	8.0	12.0	Q3
TPS79501DRBR	SON	DRB	8	3000	330.0	12.4	3.3	3.3	1.1	8.0	12.0	Q2
TPS79501DRBRG4	SON	DRB	8	3000	330.0	12.4	3.3	3.3	1.1	8.0	12.0	Q2
TPS79501DRBT	SON	DRB	8	250	180.0	12.4	3.3	3.3	1.1	8.0	12.0	Q2
TPS79516DCQR	SOT-223	DCQ	6	2500	330.0	12.4	7.1	7.45	1.88	8.0	12.0	Q3
TPS79518DCQR	SOT-223	DCQ	6	2500	330.0	12.4	7.05	7.4	1.9	8.0	12.0	Q3
TPS79518DCQRM3	SOT-223	DCQ	6	2500	330.0	12.4	7.05	7.4	1.9	8.0	12.0	Q3
TPS79525DCQR	SOT-223	DCQ	6	2500	330.0	12.4	7.1	7.45	1.88	8.0	12.0	Q3
TPS79530DCQR	SOT-223	DCQ	6	2500	330.0	12.4	7.1	7.45	1.88	8.0	12.0	Q3
TPS79533DCQR	SOT-223	DCQ	6	2500	330.0	12.4	6.85	7.3	1.88	8.0	12.0	Q3
TPS79533DCQRM3	SOT-223	DCQ	6	2500	330.0	12.4	7.05	7.4	1.9	8.0	12.0	Q3

TAPE AND REEL BOX DIMENSIONS

*All dimensions are nominal

Device	Package Type	Package Drawing	Pins	SPQ	Length (mm)	Width (mm)	Height (mm)
TPS79501DCQR	SOT-223	DCQ	6	2500	356.0	356.0	36.0
TPS79501DCQRM3	SOT-223	DCQ	6	2500	366.0	364.0	50.0
TPS79501DRBR	SON	DRB	8	3000	353.0	353.0	32.0
TPS79501DRBRG4	SON	DRB	8	3000	353.0	353.0	32.0
TPS79501DRBT	SON	DRB	8	250	213.0	191.0	35.0
TPS79516DCQR	SOT-223	DCQ	6	2500	346.0	346.0	29.0
TPS79518DCQR	SOT-223	DCQ	6	2500	340.0	340.0	38.0
TPS79518DCQRM3	SOT-223	DCQ	6	2500	340.0	340.0	38.0
TPS79525DCQR	SOT-223	DCQ	6	2500	346.0	346.0	29.0
TPS79530DCQR	SOT-223	DCQ	6	2500	346.0	346.0	29.0
TPS79533DCQR	SOT-223	DCQ	6	2500	356.0	356.0	36.0
TPS79533DCQRM3	SOT-223	DCQ	6	2500	340.0	340.0	38.0

TUBE

*All dimensions are nominal

Device	Package Name	Package Type	Pins	SPQ	L (mm)	W (mm)	T (μm)	B (mm)
TPS79501DCQ	DCQ	SOT-223	6	78	543	8.6	3606.8	2.67
TPS79501DCQ.A	DCQ	SOT-223	6	78	543	8.6	3606.8	2.67
TPS79501DCQG4	DCQ	SOT-223	6	78	532.13	8.63	3.6	3.68
TPS79501DCQG4.A	DCQ	SOT-223	6	78	532.13	8.63	3.6	3.68
TPS79533DCQ	DCQ	SOT-223	6	78	543	8.6	3606.8	2.67
TPS79533DCQ.A	DCQ	SOT-223	6	78	543	8.6	3606.8	2.67

DRB 8

GENERIC PACKAGE VIEW

VSON - 1 mm max height

PLASTIC SMALL OUTLINE - NO LEAD



Images above are just a representation of the package family, actual package may vary.
Refer to the product data sheet for package details.

4203482/L

EXAMPLE BOARD LAYOUT

DRB0008B

VSON - 1 mm max height

PLASTIC SMALL OUTLINE - NO LEAD

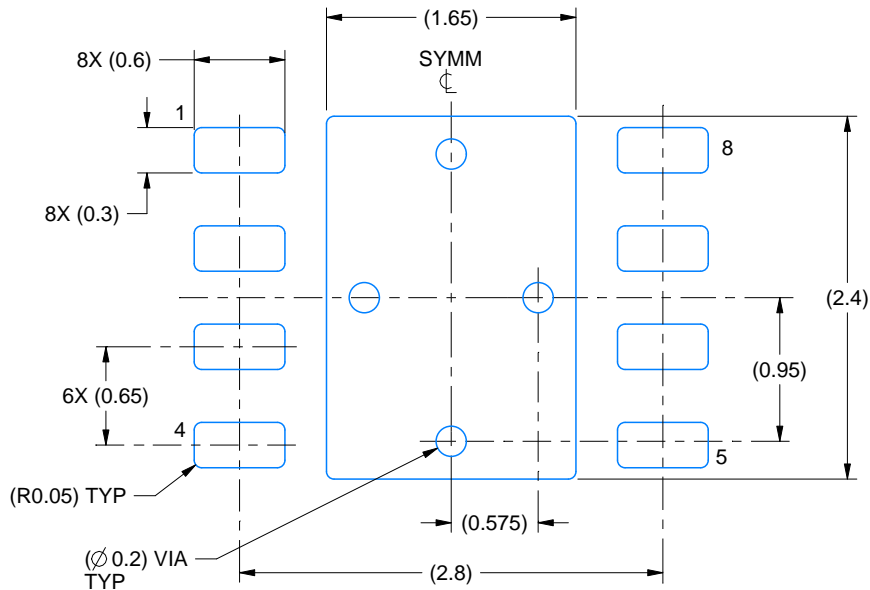

LAND PATTERN EXAMPLE
SCALE:20X

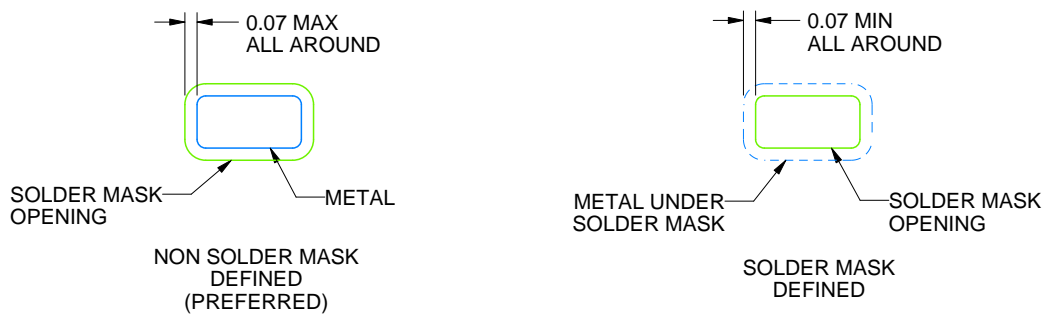

SOLDER MASK DETAILS

4218876/A 12/2017

NOTES: (continued)

4. This package is designed to be soldered to a thermal pad on the board. For more information, see Texas Instruments literature number SLUA271 (www.ti.com/lit/sluea271).
5. Vias are optional depending on application, refer to device data sheet. If any vias are implemented, refer to their locations shown on this view. It is recommended that vias under paste be filled, plugged or tented.

EXAMPLE STENCIL DESIGN

DRB0008B

VSON - 1 mm max height

PLASTIC SMALL OUTLINE - NO LEAD

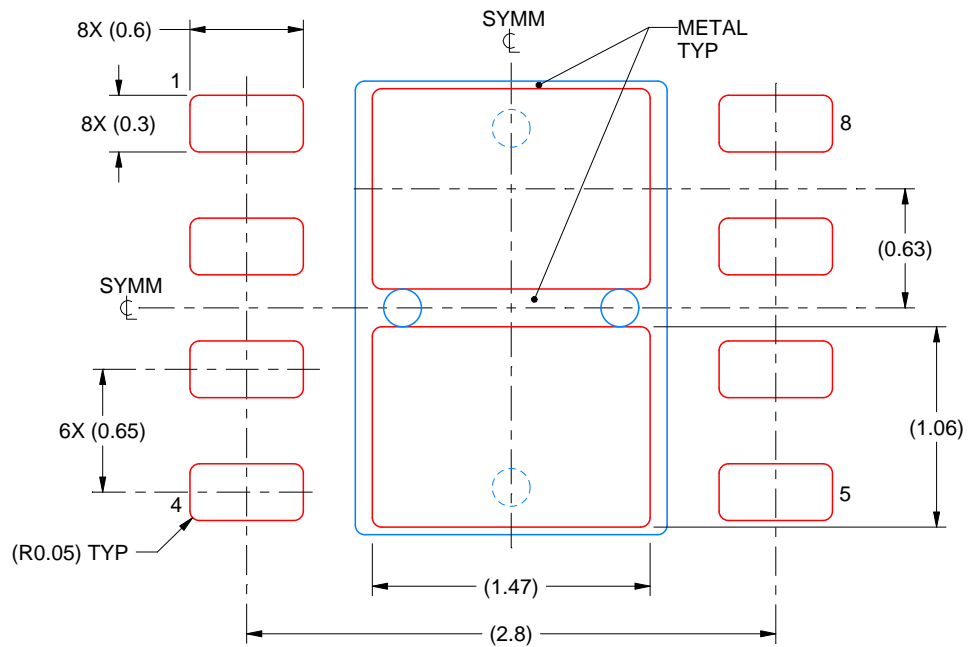

SOLDER PASTE EXAMPLE
BASED ON 0.125 mm THICK STENCIL

EXPOSED PAD
81% PRINTED SOLDER COVERAGE BY AREA
SCALE:25X

4218876/A 12/2017

NOTES: (continued)

6. Laser cutting apertures with trapezoidal walls and rounded corners may offer better paste release. IPC-7525 may have alternate design recommendations.

EXAMPLE BOARD LAYOUT

DCQ0006A

SOT - 1.8 mm max height

PLASTIC SMALL OUTLINE

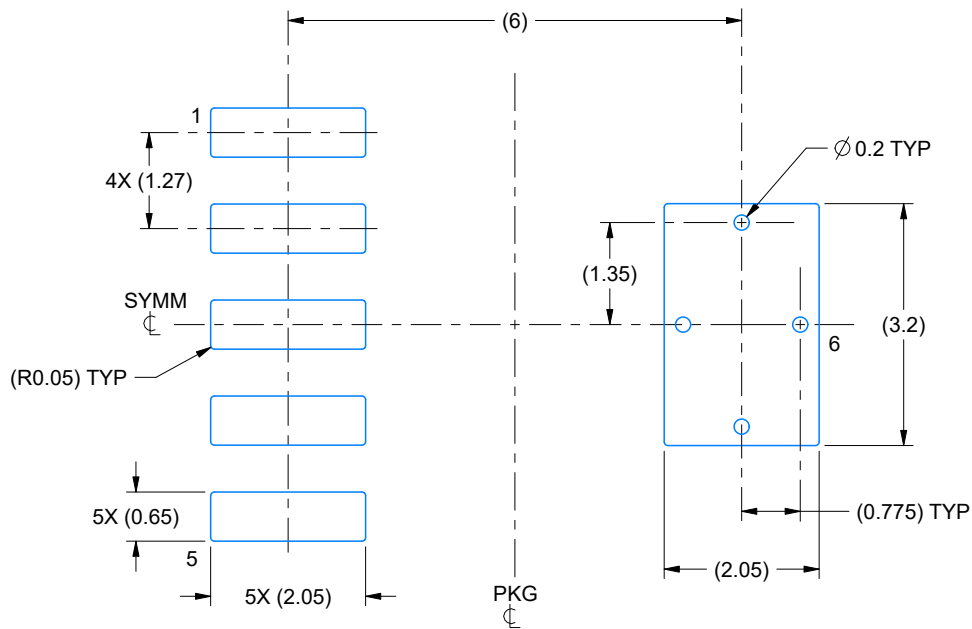

LAND PATTERN EXAMPLE
EXPOSED METAL SHOWN
SCALE: 10X

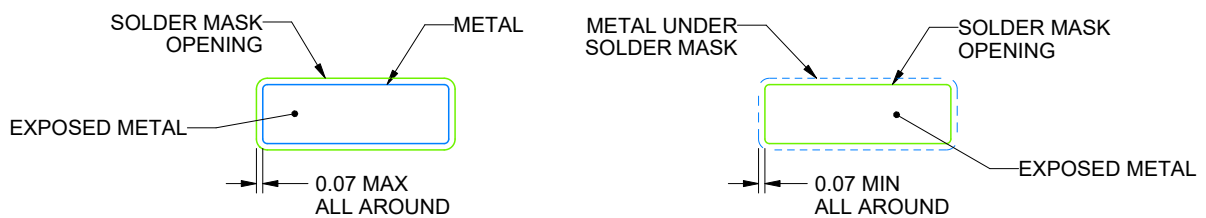

SOLDER MASK DETAILS

4214845/C 11/2021

NOTES: (continued)

4. Publication IPC-7351 may have alternate designs.
5. Solder mask tolerances between and around signal pads can vary based on board fabrication site.
6. Vias are optional depending on application, refer to device data sheet. If any vias are implemented, refer to their locations shown on this view. It is recommended that vias under paste be filled, plugged or tented.

IMPORTANT NOTICE AND DISCLAIMER

TI PROVIDES TECHNICAL AND RELIABILITY DATA (INCLUDING DATASHEETS), DESIGN RESOURCES (INCLUDING REFERENCE DESIGNS), APPLICATION OR OTHER DESIGN ADVICE, WEB TOOLS, SAFETY INFORMATION, AND OTHER RESOURCES "AS IS" AND WITH ALL FAULTS, AND DISCLAIMS ALL WARRANTIES, EXPRESS AND IMPLIED, INCLUDING WITHOUT LIMITATION ANY IMPLIED WARRANTIES OF MERCHANTABILITY, FITNESS FOR A PARTICULAR PURPOSE OR NON-INFRINGEMENT OF THIRD PARTY INTELLECTUAL PROPERTY RIGHTS.

These resources are intended for skilled developers designing with TI products. You are solely responsible for (1) selecting the appropriate TI products for your application, (2) designing, validating and testing your application, and (3) ensuring your application meets applicable standards, and any other safety, security, regulatory or other requirements.

These resources are subject to change without notice. TI grants you permission to use these resources only for development of an application that uses the TI products described in the resource. Other reproduction and display of these resources is prohibited. No license is granted to any other TI intellectual property right or to any third party intellectual property right. TI disclaims responsibility for, and you fully indemnify TI and its representatives against any claims, damages, costs, losses, and liabilities arising out of your use of these resources.

TI's products are provided subject to [TI's Terms of Sale](#), [TI's General Quality Guidelines](#), or other applicable terms available either on [ti.com](#) or provided in conjunction with such TI products. TI's provision of these resources does not expand or otherwise alter TI's applicable warranties or warranty disclaimers for TI products. Unless TI explicitly designates a product as custom or customer-specified, TI products are standard, catalog, general purpose devices.

TI objects to and rejects any additional or different terms you may propose.

Copyright © 2026, Texas Instruments Incorporated

Last updated 10/2025