

# TPS742 1.5A Ultra-LDO With Programmable Soft-Start

## 1 Features

- Input voltage range: 0.8V to 5.5V
- Soft-start (SS) pin provides a linear start-up with ramp time set by external capacitor
- 1% accuracy over line, load, and temperature
- Supports input voltages as low as 0.8V with external bias supply
- Adjustable output (0.8V to 3.6V)
- Ultra-Low Dropout:
  - 60mV (legacy chip) at 1.5A (typical)
  - 55mV (new chip) at 1.5A (typical)
- Stable with any output capacitor  $\geq 2.2\mu\text{F}$  (new chip)
- Stable with any or no output capacitor (legacy chip)
- Excellent transient response
- Open-drain power-good
- Active high enable

## 2 Applications

- [Network attached storage - enterprise](#)
- [Rack servers](#)
- [Network interface cards \(NIC\)](#)
- [Merchant network and server PSU](#)

## 3 Description

The TPS742 series of low-dropout (LDO) linear regulators provide an easy-to-use, robust power-management solution for a wide variety of applications. User-programmable soft-start minimizes stress on the input power source by reducing capacitive inrush current on start-up. The soft-start is monotonic and well suited for powering many different types of processors and ASICs. The enable input and power-good output allow easy sequencing with external regulators. This complete flexibility permits the user to configure a solution that meets the sequencing requirements of FPGAs, DSPs, and other applications with special start-up requirements.

A precision reference and error amplifier deliver 1% accuracy over load, line, temperature, and process. The device is stable with any type of capacitor greater than or equal to  $2.2\mu\text{F}$  (new chip), and is fully specified from  $-40^\circ\text{C}$  to  $125^\circ\text{C}$ .

### Package Information

PART NUMBER	PACKAGE <sup>(1)</sup>	PACKAGE SIZE <sup>(2)</sup>
TPS74201	RGW (VQFN, 20)	5mm × 5mm
	RGR (VQFN, 20)	3.5mm × 3.5mm
	KTW (DDPAK/TO-263, 7)	10.1mm × 15.24mm

- (1) For all available packages, see the [Mechanical, Packaging, and Orderable Information](#).
- (2) The package size (length × width) is a nominal value and includes pins, where applicable.

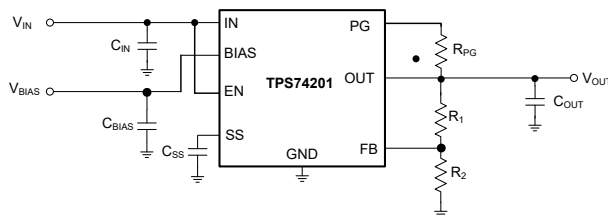

Typical Application Adjustable Output Version

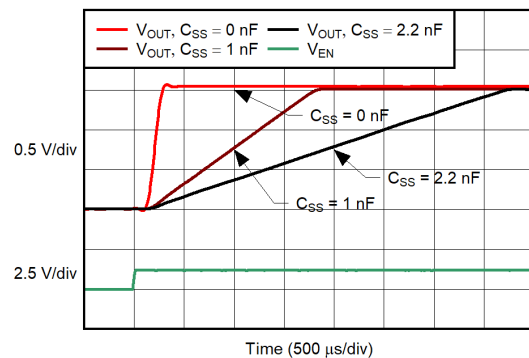

Turn-On Response



## Table of Contents

<b>1 Features</b> .....	<b>1</b>	<b>7 Application and Implementation</b> .....	<b>19</b>
<b>2 Applications</b> .....	<b>1</b>	7.1 Application Information.....	19
<b>3 Description</b> .....	<b>1</b>	7.2 Typical Applications.....	23
<b>4 Pin Configuration and Functions</b> .....	<b>3</b>	7.3 Power Supply Recommendations.....	24
<b>5 Specifications</b> .....	<b>4</b>	7.4 Layout.....	25
5.1 Absolute Maximum Ratings.....	4	<b>8 Device and Documentation Support</b> .....	<b>29</b>
5.2 ESD Ratings.....	4	8.1 Device Support.....	29
5.3 Recommended Operating Conditions.....	4	8.2 Documentation Support.....	29
5.4 Thermal Information.....	5	8.3 Receiving Notification of Documentation Updates....	29
5.5 Electrical Characteristics.....	5	8.4 Support Resources.....	29
5.6 Typical Characteristics.....	8	8.5 Trademarks.....	29
<b>6 Detailed Description</b> .....	<b>15</b>	8.6 Electrostatic Discharge Caution.....	30
6.1 Overview.....	15	8.7 Glossary.....	30
6.2 Functional Block Diagrams.....	15	<b>9 Revision History</b> .....	<b>30</b>
6.3 Feature Description.....	17	<b>10 Mechanical, Packaging, and Orderable Information</b> .....	<b>30</b>
6.4 Device Functional Modes.....	17		

## 4 Pin Configuration and Functions

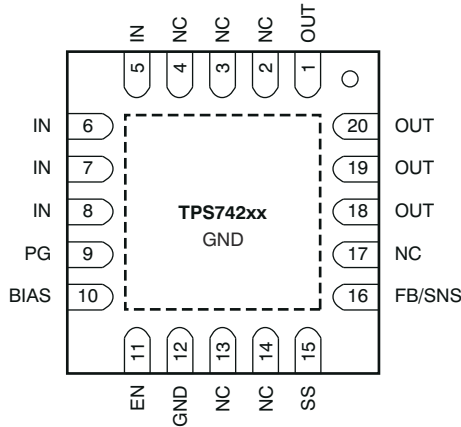

Figure 4-1. RGW and RGR Packages, 20-Pin VQFN With Exposed Thermal Pad (Top View)

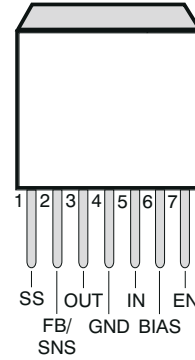

Figure 4-2. KTW Package, 7-Pin DPAK/TO-263 (Top View, Legacy Chip)

Table 4-1. Pin Functions

NAME	PIN		TYPE <sup>(1)</sup>	DESCRIPTION
	KTW <sup>(2)</sup> (DDPAK/ TO-263)	RGW, RGR <sup>(2)</sup> (VQFN)		
BIAS	6	10	I	Bias input voltage for error amplifier, reference, and internal control circuits.
EN	7	11	I	Enable pin. Driving this pin high enables the regulator. Driving this pin low puts the regulator into shutdown mode. This pin must not be left floating.
FB	2	16	I	This pin is the feedback connection to the center tap of an external resistor divider network that sets the output voltage. This pin must not be left floating. (Adjustable version only.)
GND	4	12	—	Ground
IN	5	5,6,7,8	I	Unregulated input to the device.
NC	—	2, 3,4, 13,14,17	O	No connection. This pin can be left floating or connected to GND to allow better thermal contact to the top-side plane.
OUT	3	1, 18, 19, 20	O	Regulated output voltage. No capacitor is required on this pin for stability.
PAD/TAB	—	—	—	Solder to the ground plane for increased thermal performance.
PG	—	9	O	Power-good (PG) is an open-drain, active-high output that indicates the status of $V_{OUT}$ . When $V_{OUT}$ exceeds the PG trip threshold, the PG pin goes into a high-impedance state. When $V_{OUT}$ is below this threshold the pin is driven to a low-impedance state. Connect a pullup resistor from 10kΩ to 1MΩ from this pin to a supply up to 5.5V. The supply can be higher than the input voltage. Alternatively, the PG pin can be left floating if output monitoring is not necessary.
SNS	2	16	I	This pin is the sense connection to the load device. This pin must be connected to $V_{OUT}$ and must not be left floating. (Fixed versions only.)
SS	1	15	—	Soft-start pin. A capacitor connected on this pin to ground sets the start-up time. If this pin is left floating, the regulator output soft-start ramp time is typically 100μs.

(1) I = Input; O = Output;

(2) The RGR and KTW package are only for the legacy device.

## 5 Specifications

### 5.1 Absolute Maximum Ratings

over operating temperature range (unless otherwise noted)<sup>(1)</sup>

		MIN	MAX	UNIT
V <sub>IN</sub> , V <sub>BIAS</sub>	Input voltage	-0.3	6	V
V <sub>EN</sub>	Enable voltage	-0.3	6	V
V <sub>PG</sub>	Power good voltage	-0.3	6	V
I <sub>PG</sub>	PG sink current	0	1.5	mA
V <sub>SS</sub>	Soft-start voltage	-0.3	6	V
V <sub>FB</sub>	Feedback voltage	-0.3	6	V
V <sub>OUT</sub>	Output voltage	-0.3	V <sub>IN</sub> + 0.3	V
I <sub>OUT</sub>	Maximum output current	Internally limited		
	Output short-circuit duration	Indefinite		
P <sub>DISS</sub>	Continuous total power dissipation	See Thermal Information		
T <sub>J</sub>	Junction Temperature (Legacy Chip)	-40	125	°C
	Junction Temperature (New Chip)	-40	150	°C
T <sub>stg</sub>	Storage Temperature	-55	150	

- (1) Operation outside the Absolute Maximum Ratings may cause permanent device damage. Absolute Maximum Ratings do not imply functional operation of the device at these or any other conditions beyond those listed under Recommended Operating Conditions. If used outside the Recommended Operating Conditions but within the Absolute Maximum Ratings, the device may not be fully functional, and this may affect device reliability, functionality, performance, and shorten the device lifetime.

### 5.2 ESD Ratings

		VALUE	UNIT
V <sub>(ESD)</sub>	Electrostatic discharge	Human body model (HBM), per ANSI/ESDA/JEDEC JS-001, all pins <sup>(1)</sup>	±2000
		Charged device model (CDM), per JEDEC specification JESD22-C101, all pins <sup>(2)</sup>	±500

- (1) JEDEC document JEP155 states that 500-V HBM allows safe manufacturing with a standard ESD control process.  
(2) JEDEC document JEP157 states that 250-V CDM allows safe manufacturing with a standard ESD control process.

### 5.3 Recommended Operating Conditions

over operating free-air temperature range (unless otherwise noted)

		MIN	NOM	MAX	UNIT
V <sub>IN</sub>	Input supply voltage	V <sub>OUT</sub> + V <sub>DO</sub> (V <sub>IN</sub> )	V <sub>OUT</sub> + 0.3	5.5	V
V <sub>EN</sub>	Enable supply voltage		V <sub>IN</sub>	5.5	V
V <sub>BIAS</sub> <sup>(1)</sup>	BIAS supply voltage	V <sub>OUT</sub> + V <sub>DO</sub> (V <sub>BIAS</sub> ) <sup>(2)</sup>	V <sub>OUT</sub> + 1.6 <sup>(2)</sup>	5.5	V
V <sub>OUT</sub>	Output voltage	0.8		3.6	V
I <sub>OUT</sub>	Output current	0		1.5	A
C <sub>OUT</sub>	Output capacitor (legacy chip)	0			μF
	Output capacitor (new chip)	2.2			μF
C <sub>IN</sub>	Input capacitor <sup>(3)</sup>	1			μF
C <sub>BIAS</sub>	Bias capacitor	0.1	1		μF
T <sub>J</sub>	Operating junction temperature	-40		125	°C

- (1) BIAS supply is required when V<sub>IN</sub> is below V<sub>OUT</sub> + V<sub>DO</sub> (V<sub>BIAS</sub>).  
(2) V<sub>BIAS</sub> has a minimum voltage of 2.7 V or V<sub>OUT</sub> + V<sub>DO</sub> (V<sub>BIAS</sub>), whichever is higher (new chip).  
(3) If V<sub>IN</sub> and V<sub>BIAS</sub> are connected to the same supply, the recommended minimum capacitor for the supply is 4.7 μF.

## 5.4 Thermal Information

THERMAL METRIC <sup>(1)</sup>		TPS742				UNIT
		RGW (VQFN) (legacy chip)	RGW (VQFN) (new chip)	RGR (VQFN)	KTW (DDPAK/ TO-263)	
		20 PINS	20 PINS	20 PINS	7 PINS	
R <sub>θJA</sub>	Junction-to-ambient thermal resistance	35.4	34.7	44.2	47.2	°C/W
R <sub>θJC(top)</sub>	Junction-to-case (top) thermal resistance	32.4	31	50.3	63.7	°C/W
R <sub>θJB</sub>	Junction-to-board thermal resistance	14.7	13.5	19.6	19.5	°C/W
ψ <sub>JT</sub>	Junction-to-top characterization parameter	0.4	1.4	0.7	4.2	°C/W
ψ <sub>JB</sub>	Junction-to-board characterization parameter	14.8	13.5	17.8	19.4	°C/W
R <sub>θJC(bot)</sub>	Junction-to-case (bottom) thermal resistance	3.9	3.6	4.3	3.3	°C/W

(1) For more information about traditional and new thermal metrics, see the [Semiconductor and IC Package Thermal Metrics](#) application note.

## 5.5 Electrical Characteristics

at V<sub>EN</sub> = 1.1 V, V<sub>IN</sub> = V<sub>OUT</sub> + 0.3 V, C<sub>BIAS</sub> = 0.1 μF, C<sub>IN</sub> = C<sub>OUT</sub> = 10 μF, I<sub>OUT</sub> = 50 mA, V<sub>BIAS</sub> = 5.0 V, and T<sub>J</sub> = –40°C to 125°C, (unless otherwise noted); typical values are at T<sub>J</sub> = 25°C

PARAMETER		TEST CONDITIONS	MIN	TYP	MAX	UNIT	
V <sub>IN</sub>	Input voltage range		V <sub>OUT</sub> + V <sub>DO</sub>		5.5	V	
V <sub>BIAS</sub>	BIAS pin voltage range		2.375		5.25	V	
V <sub>REF</sub>	Internal reference	T <sub>J</sub> = 25°C	0.796	0.8	0.804	V	
V <sub>OUT</sub>	Output voltage	V <sub>IN</sub> = 5V, I <sub>OUT</sub> = 1.5A, V <sub>BIAS</sub> = 5V	V <sub>REF</sub>		3.6	V	
V <sub>OUT</sub>	Accuracy <sup>(1)</sup>	2.375V ≤ V <sub>BIAS</sub> ≤ 5.25V, V <sub>OUT</sub> + 1.62V ≤ V <sub>BIAS</sub> 50mA ≤ I <sub>OUT</sub> ≤ 1.5A	-1	±0.2	1	%	
ΔV <sub>OUT(ΔVIN)</sub>	Line regulation	V <sub>OUT(NOM)</sub> + 0.3V ≤ V <sub>IN</sub> ≤ 5.5V, VQFN		0.0005	0.05	%V	
		V <sub>OUT(NOM)</sub> + 0.3V ≤ V <sub>IN</sub> ≤ 5.5V, DDPAK/TO-263		0.0005	0.06		
ΔV <sub>OUT(ΔIOUT)</sub>	Load regulation	0 mA ≤ I <sub>OUT</sub> ≤ 50mA (Legacy Chip)		0.013		%/mA	
		50 mA ≤ I <sub>OUT</sub> ≤ 1.5 A (Legacy Chip)		0.04		%A	
		50 mA ≤ I <sub>OUT</sub> ≤ 1.5 A (New Chip)		0.09			
V <sub>DO</sub>	V <sub>IN</sub> dropout voltage <sup>(2)</sup>	I <sub>OUT</sub> = 1.5 A, V <sub>BIAS</sub> – V <sub>OUT(NOM)</sub> ≥ 1.62 V, VQFN		55	100	mV	
		I <sub>OUT</sub> = 1.5 A, V <sub>BIAS</sub> – V <sub>OUT(NOM)</sub> ≥ 1.62 V, DDPAK/TO-263 (Legacy chip only)		60	120		
	V <sub>BIAS</sub> dropout voltage <sup>(2)</sup>	I <sub>OUT</sub> = 1.5A, V <sub>IN</sub> = V <sub>BIAS</sub> (Legacy Chip)				1.4	V
		I <sub>OUT</sub> = 1.5A, V <sub>IN</sub> = V <sub>BIAS</sub> (New Chip)				1.43	
I <sub>CL</sub>	Current limit	V <sub>OUT</sub> = 80% × V <sub>OUT(nom)</sub> , (Legacy Chip)	1.8		4	A	
		V <sub>OUT</sub> = 80% × V <sub>OUT(nom)</sub> , (New Chip)	2		5.5		
I <sub>BIAS</sub>	BIAS pin current	I <sub>OUT</sub> = 0mA to 1.5A (Legacy Chip)		2	4	mA	
		I <sub>OUT</sub> = 0mA to 1.5A (New Chip)		1	2		

## 5.5 Electrical Characteristics (continued)

at  $V_{EN} = 1.1\text{ V}$ ,  $V_{IN} = V_{OUT} + 0.3\text{ V}$ ,  $C_{BIAS} = 0.1\text{ }\mu\text{F}$ ,  $C_{IN} = C_{OUT} = 10\text{ }\mu\text{F}$ ,  $I_{OUT} = 50\text{ mA}$ ,  $V_{BIAS} = 5.0\text{ V}$ , and  $T_J = -40^\circ\text{C}$  to  $125^\circ\text{C}$ , (unless otherwise noted); typical values are at  $T_J = 25^\circ\text{C}$

PARAMETER		TEST CONDITIONS	MIN	TYP	MAX	UNIT
$I_{SHDN}$	Shutdown supply current ( $I_{GND}$ )	$V_{EN} \leq 0.4\text{ V}$ (Legacy Chip)		1	100	$\mu\text{A}$
		$V_{EN} \leq 0.4\text{ V}$ , (New Chip)		0.85	2.75	
$I_{FB}$	Feedback pin current <sup>(3)</sup>	$I_{OUT} = 50\text{ mA}$ to $1.5\text{ A}$ (Legacy Chip)	-250	68	250	nA
		$I_{OUT} = 50\text{ mA}$ to $1.5\text{ A}$ (New Chip)	-30	0.15	30	nA
PSRR	Power-supply rejection ( $V_{IN}$ to $V_{OUT}$ )	1 kHz, $I_{OUT} = 1.5\text{ A}$ , $V_{IN} = 1.8\text{ V}$ , $V_{OUT} = 1.5\text{ V}$ (Legacy Chip)		73		dB
		1 kHz, $I_{OUT} = 1.5\text{ A}$ , $V_{IN} = 1.8\text{ V}$ , $V_{OUT} = 1.5\text{ V}$ (New Chip)		60		
		300 kHz, $I_{OUT} = 1.5\text{ A}$ , $V_{IN} = 1.8\text{ V}$ , $V_{OUT} = 1.5\text{ V}$ (Legacy Chip)		42		
		300 kHz, $I_{OUT} = 1.5\text{ A}$ , $V_{IN} = 1.8\text{ V}$ , $V_{OUT} = 1.5\text{ V}$ (New Chip)		30		
	Power-supply rejection ( $V_{BIAS}$ to $V_{OUT}$ )	1kHz, $I_{OUT} = 1.5\text{ A}$ , $V_{IN} = 1.8\text{ V}$ , $V_{OUT} = 1.5\text{ V}$ (Legacy Chip)		62		
		1kHz, $I_{OUT} = 1.5\text{ A}$ , $V_{IN} = 1.8\text{ V}$ , $V_{OUT} = 1.5\text{ V}$ (New Chip)		59		
$V_n$	Output noise voltage	BW = 100Hz to 100kHz, $I_{OUT} = 1.5\text{ A}$ , $C_{SS} = 1\text{ nF}$ (Legacy Chip)		16		$\mu\text{Vrms} \times V_{out}$
		BW = 100 Hz to 100 kHz, $I_{OUT} = 3\text{ A}$ , $C_{SS} = 1\text{ nF}$ (New Chip)		20		
$V_{TRAN}$	% $V_{OUT}$ droop during load transient	$I_{OUT} = 50\text{ mA}$ to $1.5\text{ A}$ at $1\text{ A}/\mu\text{s}$ , $C_{OUT} = \text{none}$ (Legacy Chip)		3.5		% $V_{OUT}$
$V_{TRAN}$	% $V_{OUT}$ droop during load transient	$I_{OUT} = 50\text{ mA}$ to $1.5\text{ A}$ at $1\text{ A}/\mu\text{s}$ , $C_{OUT} = 2.2\text{ }\mu\text{F}$ (New Chip)		1.7		% $V_{OUT}$
$t_{STR}$	Minimum start-up time	$R_{LOAD}$ for $I_{OUT} = 1.5\text{ A}$ , $C_{SS} = \text{open}$ (Legacy Chip)		100		$\mu\text{s}$
		$R_{LOAD}$ for $I_{OUT} = 1.0\text{ A}$ , $C_{SS} = \text{open}$ (New Chip)		250		
$I_{SS}$	Soft-start charging current	$V_{SS} = 0.4\text{ V}$ , $I_{OUT} = 0\text{ mA}$ (Legacy Chip)	0.500	0.730	1	$\mu\text{A}$
		$V_{SS} = 0.4\text{ V}$ , $I_{OUT} = 0\text{ mA}$ (New Chip)	0.300	0.530	0.800	
$V_{EN(hi)}$	Enable input high level		1.1		5.5	V
$V_{EN(lo)}$	Enable input low level		0		0.4	V
$V_{EN(hys)}$	Enable pin hysteresis	(Legacy Chip)		50		mV
		(New Chip)		55		
$V_{EN(dg)}$	Enable pin deglitch time			20		$\mu\text{s}$
$I_{EN}$	Enable pin current	$V_{EN} = 5\text{ V}$ (Legacy Chip)		0.1	1	$\mu\text{A}$
		$V_{EN} = 5\text{ V}$ (New Chip)		0.1	0.25	

## 5.5 Electrical Characteristics (continued)

at  $V_{EN} = 1.1\text{ V}$ ,  $V_{IN} = V_{OUT} + 0.3\text{ V}$ ,  $C_{BIAS} = 0.1\text{ }\mu\text{F}$ ,  $C_{IN} = C_{OUT} = 10\text{ }\mu\text{F}$ ,  $I_{OUT} = 50\text{ mA}$ ,  $V_{BIAS} = 5.0\text{ V}$ , and  $T_J = -40^\circ\text{C}$  to  $125^\circ\text{C}$ , (unless otherwise noted); typical values are at  $T_J = 25^\circ\text{C}$

PARAMETER		TEST CONDITIONS	MIN	TYP	MAX	UNIT
$V_{IT}$	PG trip threshold	$V_{OUT}$ decreasing (Legacy Chip)	86.5	90	93.5	% $V_{OUT}$
		$V_{OUT}$ decreasing (New Chip)	85	90	94	
$V_{HYS}$	PG trip hysteresis	(Legacy Chip)		3		% $V_{OUT}$
		(New Chip)		2.5		
$V_{PG(lo)}$	PG output low voltage	$I_{PG} = 1\text{ mA}$ (sinking), $V_{OUT} < V_{IT}$ (Legacy Chip)			0.3	V
		$I_{PG} = 1\text{ mA}$ (sinking), $V_{OUT} < V_{IT}$ (New Chip)			0.12	
$I_{PG(ikg)}$	PG leakage current	$V_{PG} = 5.25\text{ V}$ , $V_{OUT} > V_{IT}$ (Legacy Chip)		0.03	1	$\mu\text{A}$
		$V_{PG} = 5.25\text{ V}$ , $V_{OUT} > V_{IT}$ (New Chip)		0.001	0.05	
$T_J$	Operating junction temperature		-40		125	$^\circ\text{C}$
$T_{SD}$	Thermal shutdown temperature	Shutdown, temperature increasing (Legacy Chip)		155		$^\circ\text{C}$
		Shutdown, temperature increasing (New Chip)		165		
		Reset, temperature decreasing		140		

- (1) For adjustable devices tested at 0.8V, resistor tolerance is not taken into account.
- (2) Dropout is defined as the voltage from the input to  $V_{OUT}$  when  $V_{OUT}$  is 2% below nominal.
- (3)  $I_{FB}$  current flow is out of the device.

### 5.6 Typical Characteristics

at  $T_J = 25^\circ\text{C}$ ,  $V_{OUT} = 1.5\text{V}$ ,  $V_{IN} = V_{OUT(NOM)} + 0.3\text{V}$ ,  $V_{BIAS} = 3.3\text{V}$  (legacy chip),  $V_{BIAS} = 5.0\text{V}$  (new chip),  $I_{OUT} = 50\text{mA}$ ,  $V_{EN} = V_{IN}$ ,  $C_{IN} = 1\mu\text{F}$ ,  $C_{BIAS} = 4.7\mu\text{F}$ ,  $C_{SS} = 0.01\mu\text{F}$  (legacy chip), and  $C_{OUT} = 10\mu\text{F}$  (unless otherwise noted)

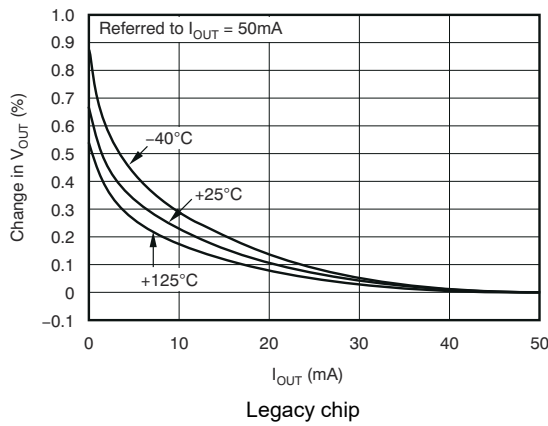

**Figure 5-1. Load Regulation**

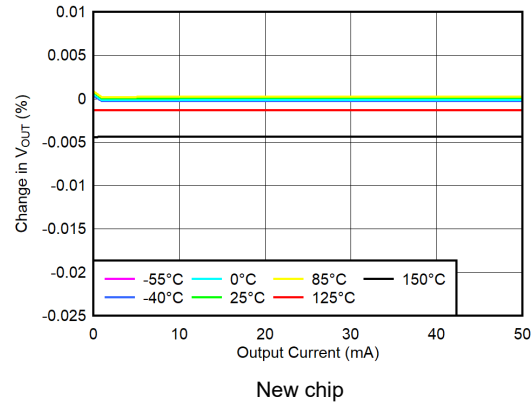

**Figure 5-2. Load Regulation at Light Load**

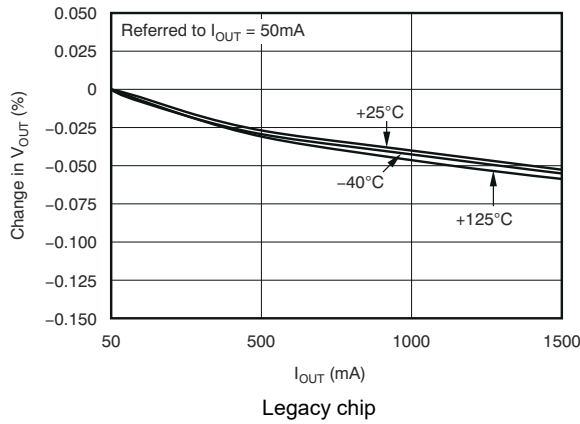

**Figure 5-3. Load Regulation**

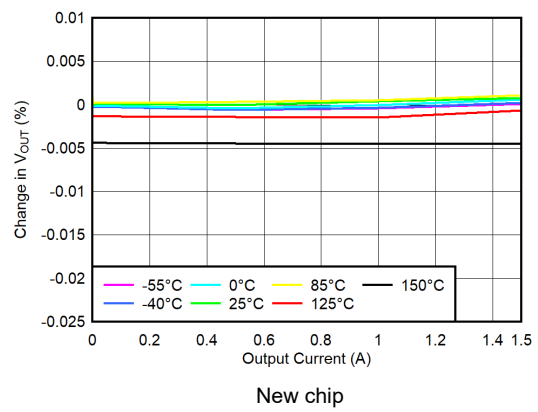

**Figure 5-4. Load Regulation**

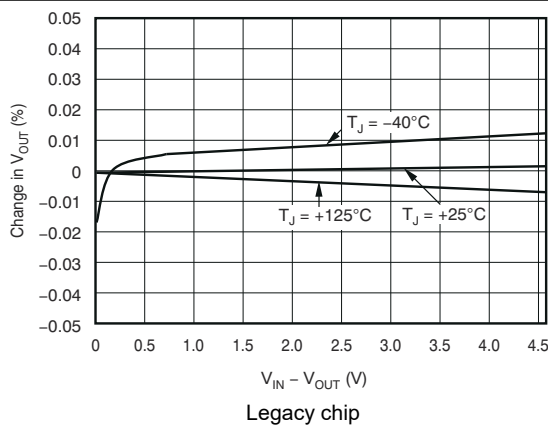

**Figure 5-5. Line Regulation**

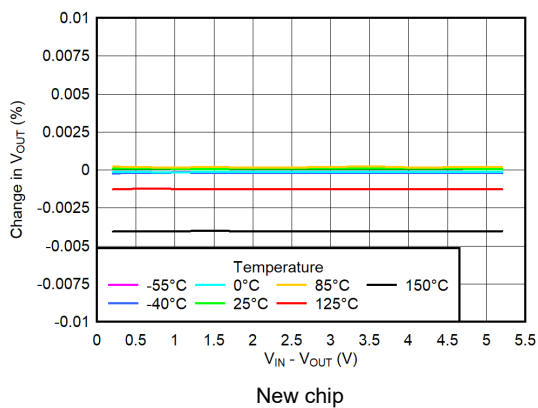

**Figure 5-6. Line Regulation**

### 5.6 Typical Characteristics (continued)

at  $T_J = 25^\circ\text{C}$ ,  $V_{OUT} = 1.5\text{V}$ ,  $V_{IN} = V_{OUT(NOM)} + 0.3\text{V}$ ,  $V_{BIAS} = 3.3\text{V}$  (legacy chip),  $V_{BIAS} = 5.0\text{V}$  (new chip),  $I_{OUT} = 50\text{mA}$ ,  $V_{EN} = V_{IN}$ ,  $C_{IN} = 1\mu\text{F}$ ,  $C_{BIAS} = 4.7\mu\text{F}$ ,  $C_{SS} = 0.01\mu\text{F}$  (legacy chip), and  $C_{OUT} = 10\mu\text{F}$  (unless otherwise noted)

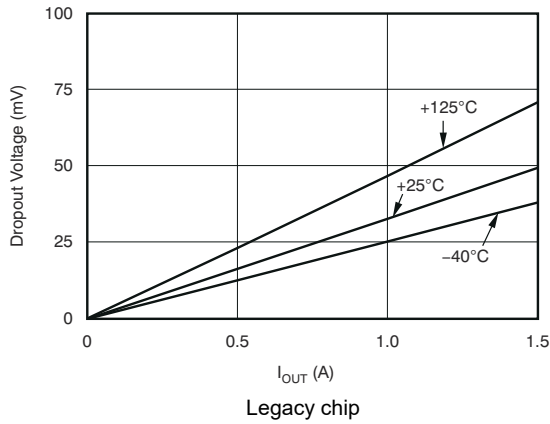

Figure 5-7.  $V_{IN}$  Dropout Voltage vs  $I_{OUT}$  and Temperature ( $T_J$ )

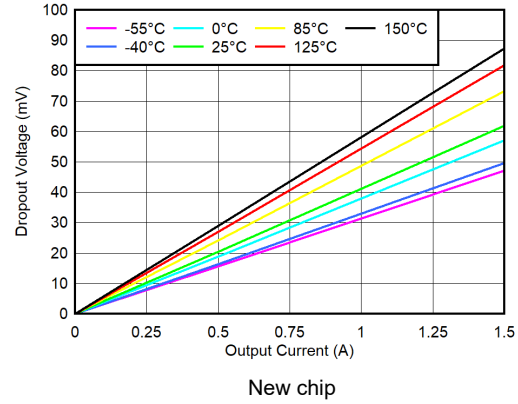

Figure 5-8.  $V_{IN}$  Dropout Voltage vs  $I_{OUT}$  and Temperature ( $T_J$ )

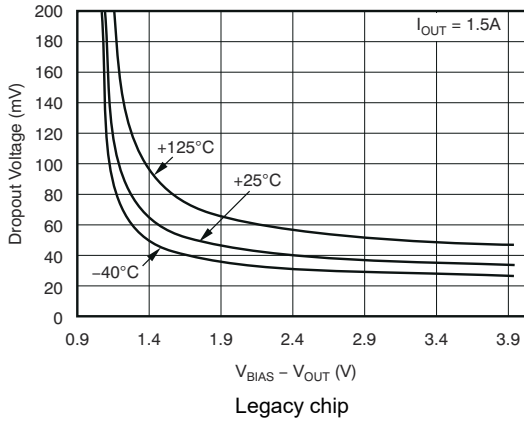

Figure 5-9.  $V_{IN}$  Dropout Voltage vs  $V_{BIAS} - V_{OUT}$  and Temperature ( $T_J$ )

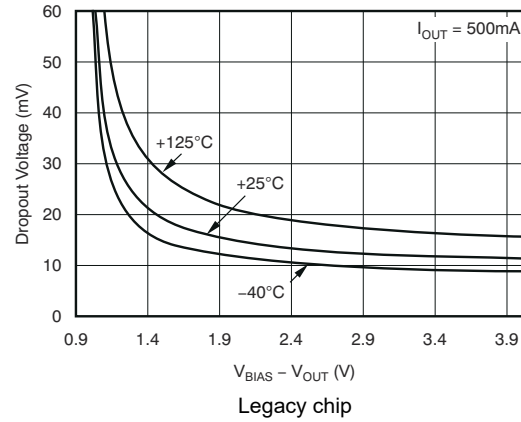

Figure 5-10.  $V_{IN}$  Dropout Voltage vs  $V_{BIAS} - V_{OUT}$  and Temperature ( $T_J$ )

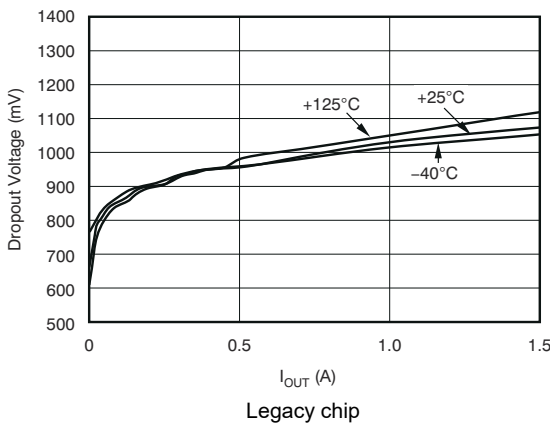

Figure 5-11.  $V_{BIAS}$  Dropout Voltage vs  $I_{OUT}$  and Temperature

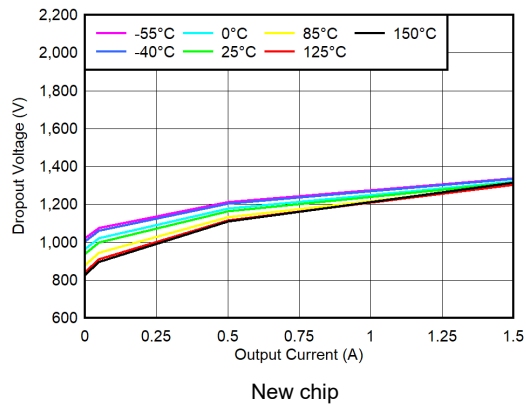

Figure 5-12.  $V_{BIAS}$  Dropout Voltage vs  $I_{OUT}$  and Temperature ( $T_J$ )

### 5.6 Typical Characteristics (continued)

at  $T_J = 25^\circ\text{C}$ ,  $V_{OUT} = 1.5\text{V}$ ,  $V_{IN} = V_{OUT(NOM)} + 0.3\text{V}$ ,  $V_{BIAS} = 3.3\text{V}$  (legacy chip),  $V_{BIAS} = 5.0\text{V}$  (new chip),  $I_{OUT} = 50\text{mA}$ ,  $V_{EN} = V_{IN}$ ,  $C_{IN} = 1\mu\text{F}$ ,  $C_{BIAS} = 4.7\mu\text{F}$ ,  $C_{SS} = 0.01\mu\text{F}$  (legacy chip), and  $C_{OUT} = 10\mu\text{F}$  (unless otherwise noted)

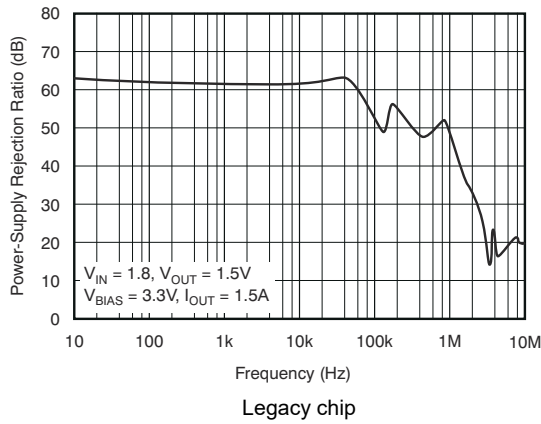

Figure 5-13.  $V_{BIAS}$  PSRR vs Frequency

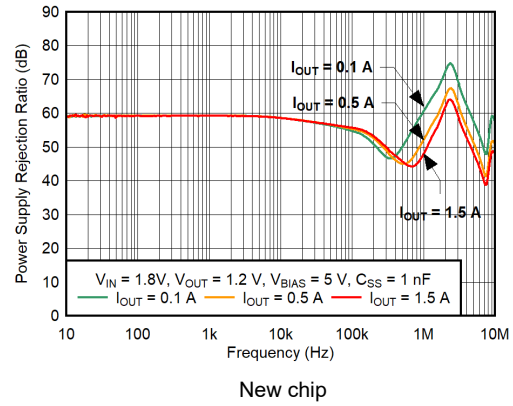

Figure 5-14.  $V_{BIAS}$  PSRR vs Frequency

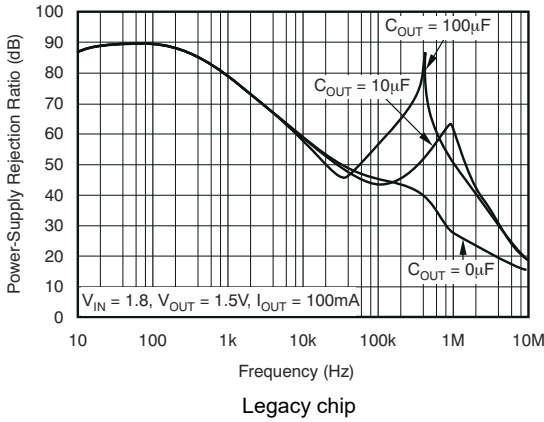

Figure 5-15.  $V_{IN}$  PSRR vs Frequency

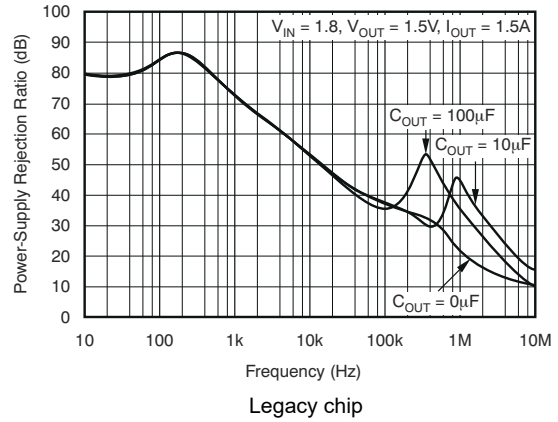

Figure 5-16.  $V_{IN}$  PSRR vs Frequency

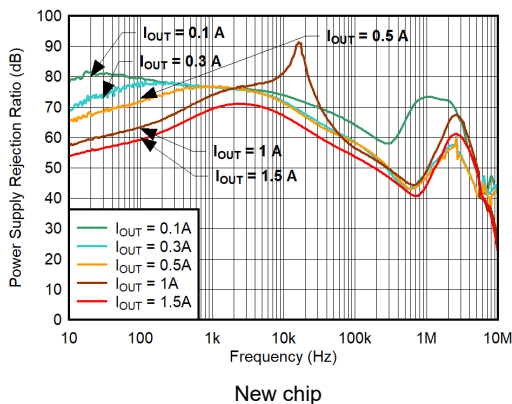

Figure 5-17.  $V_{IN}$  PSRR vs Frequency

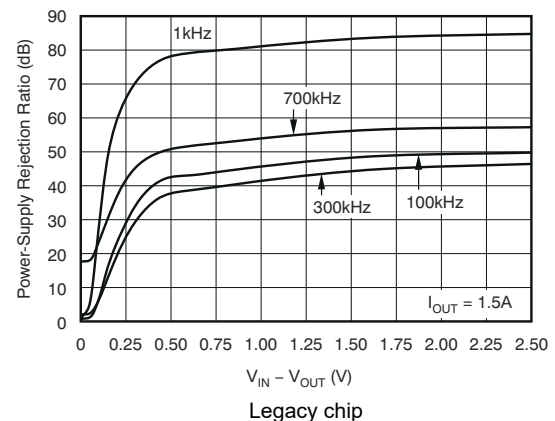
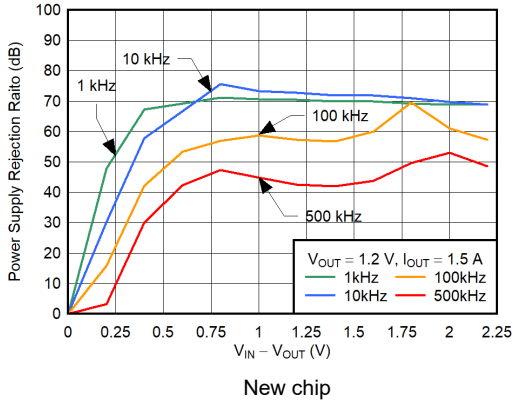

Figure 5-18.  $V_{IN}$  PSRR vs  $V_{IN} - V_{OUT}$

### 5.6 Typical Characteristics (continued)

at  $T_J = 25^\circ\text{C}$ ,  $V_{OUT} = 1.5\text{V}$ ,  $V_{IN} = V_{OUT(NOM)} + 0.3\text{V}$ ,  $V_{BIAS} = 3.3\text{V}$  (legacy chip),  $V_{BIAS} = 5.0\text{V}$  (new chip),  $I_{OUT} = 50\text{mA}$ ,  $V_{EN} = V_{IN}$ ,  $C_{IN} = 1\mu\text{F}$ ,  $C_{BIAS} = 4.7\mu\text{F}$ ,  $C_{SS} = 0.01\mu\text{F}$  (legacy chip), and  $C_{OUT} = 10\mu\text{F}$  (unless otherwise noted)



**Figure 5-19.  $V_{IN}$  PSRR vs  $(V_{IN} - V_{OUT})$**

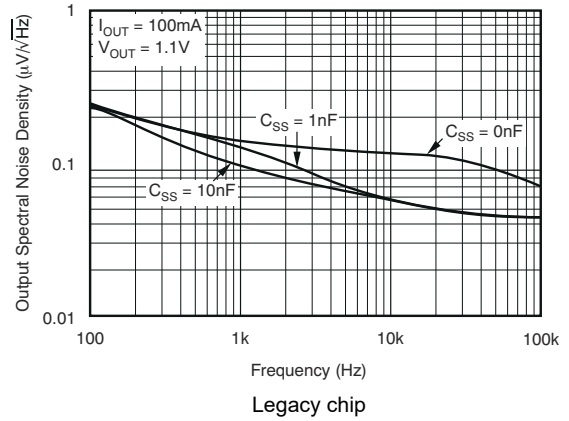

**Figure 5-20. Noise Spectral Density**

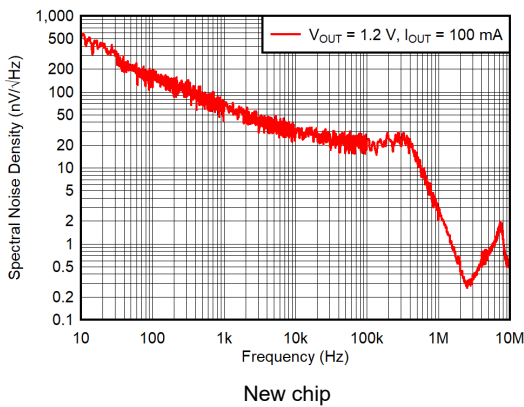

**Figure 5-21. Noise Spectral Density**

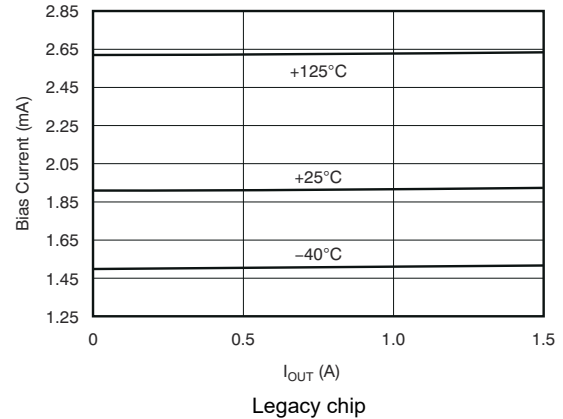

**Figure 5-22.  $I_{BIAS}$  vs  $I_{OUT}$  and Temperature**

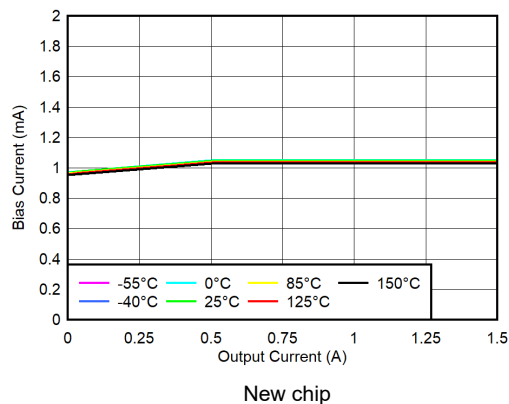

**Figure 5-23. BIAS Pin Current vs Output Current and Temperature ( $T_J$ )**

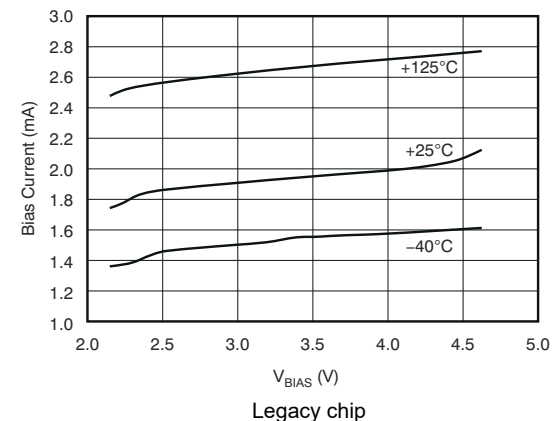

**Figure 5-24.  $I_{BIAS}$  vs  $V_{BIAS}$  and  $V_{OUT}$**

### 5.6 Typical Characteristics (continued)

at  $T_J = 25^\circ\text{C}$ ,  $V_{OUT} = 1.5\text{V}$ ,  $V_{IN} = V_{OUT(NOM)} + 0.3\text{V}$ ,  $V_{BIAS} = 3.3\text{V}$  (legacy chip),  $V_{BIAS} = 5.0\text{V}$  (new chip),  $I_{OUT} = 50\text{mA}$ ,  $V_{EN} = V_{IN}$ ,  $C_{IN} = 1\mu\text{F}$ ,  $C_{BIAS} = 4.7\mu\text{F}$ ,  $C_{SS} = 0.01\mu\text{F}$  (legacy chip), and  $C_{OUT} = 10\mu\text{F}$  (unless otherwise noted)

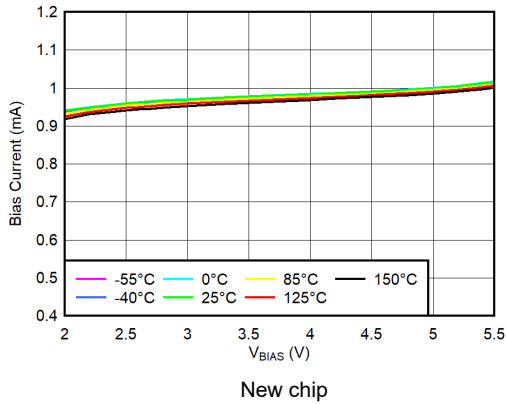

**Figure 5-25. BIAS Pin Current vs  $V_{BIAS}$  and Temperature ( $T_J$ )**

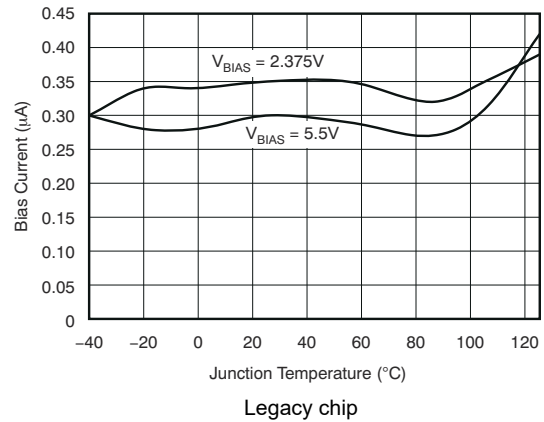

**Figure 5-26.  $I_{BIAS}$  Shutdown vs Temperature**

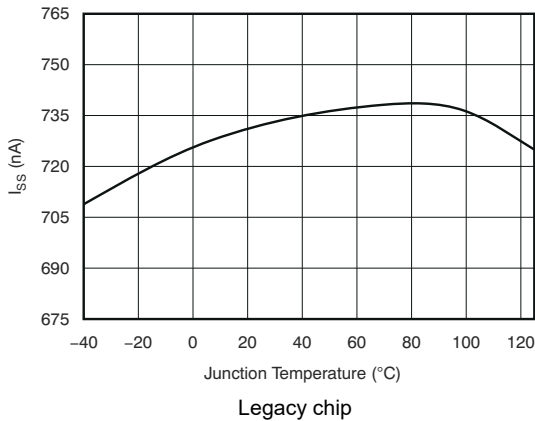

**Figure 5-27. Soft-Start Charging Current ( $I_{SS}$ ) vs Temperature**

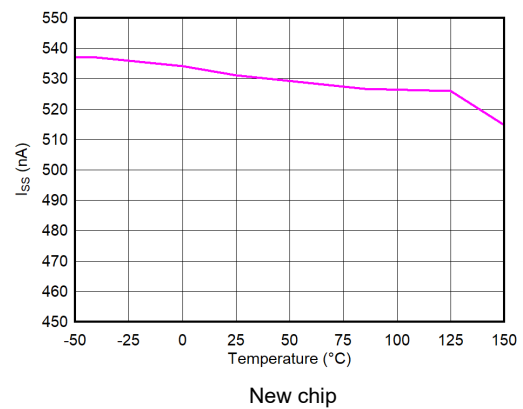

**Figure 5-28. Soft-Start Charging Current ( $I_{SS}$ ) vs Temperature ( $T_J$ )**

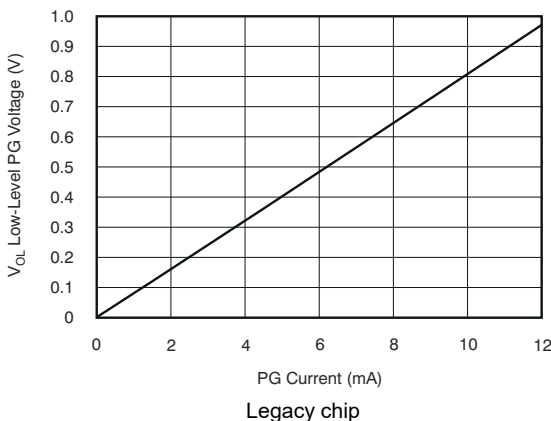

**Figure 5-29. Low-Level PG Voltage vs PG Current**

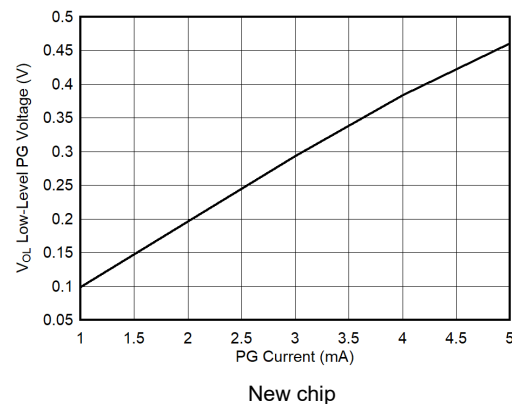

**Figure 5-30. Low-Level PG Voltage vs Current**

### 5.6 Typical Characteristics (continued)

at  $T_J = 25^\circ\text{C}$ ,  $V_{OUT} = 1.5\text{V}$ ,  $V_{IN} = V_{OUT(NOM)} + 0.3\text{V}$ ,  $V_{BIAS} = 3.3\text{V}$  (legacy chip),  $V_{BIAS} = 5.0\text{V}$  (new chip),  $I_{OUT} = 50\text{mA}$ ,  $V_{EN} = V_{IN}$ ,  $C_{IN} = 1\mu\text{F}$ ,  $C_{BIAS} = 4.7\mu\text{F}$ ,  $C_{SS} = 0.01\mu\text{F}$  (legacy chip), and  $C_{OUT} = 10\mu\text{F}$  (unless otherwise noted)

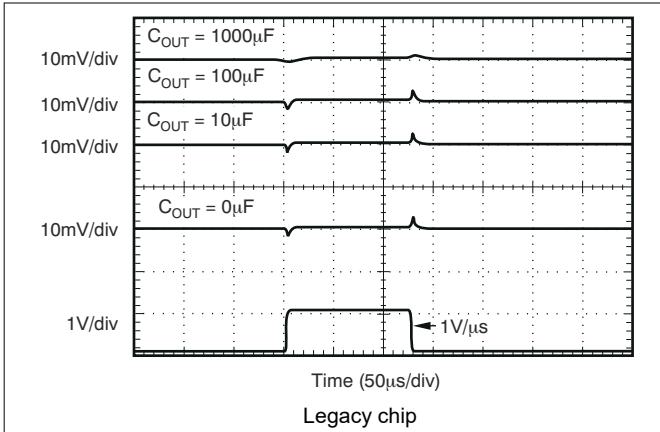

Figure 5-31.  $V_{BIAS}$  Line Transient (1.5A)

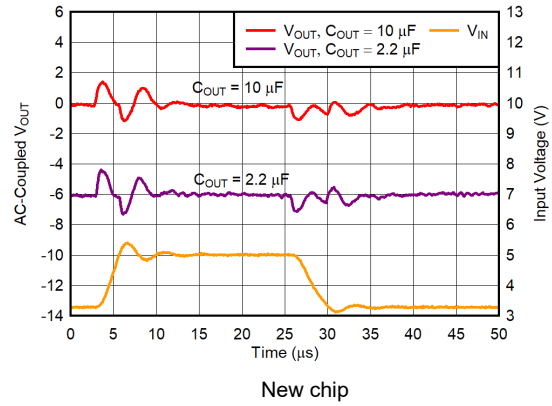

Figure 5-32.  $V_{BIAS}$  Line Transient

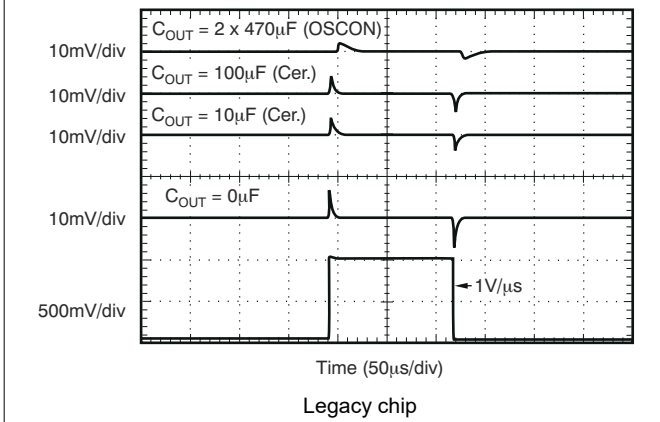

Figure 5-33.  $V_{IN}$  Line Transient

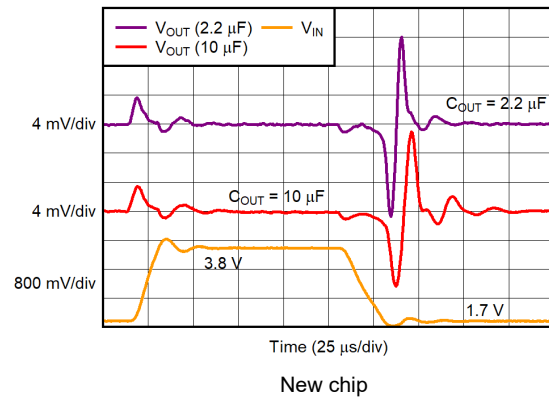

Figure 5-34.  $V_{IN}$  Line Transient

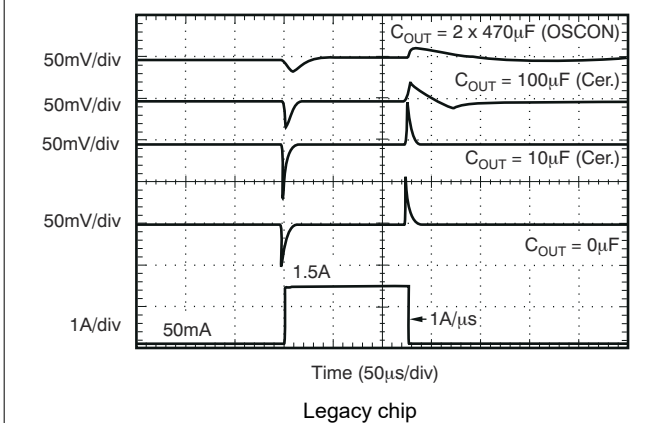

Figure 5-35. Output Load Transient Response

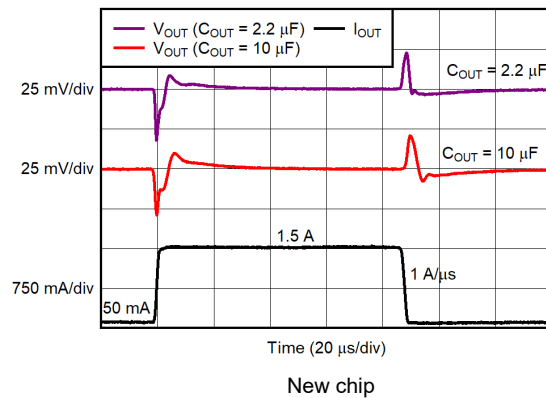

Figure 5-36. Output Load Transient Response

### 5.6 Typical Characteristics (continued)

at  $T_J = 25^\circ\text{C}$ ,  $V_{OUT} = 1.5\text{V}$ ,  $V_{IN} = V_{OUT(NOM)} + 0.3\text{V}$ ,  $V_{BIAS} = 3.3\text{V}$  (legacy chip),  $V_{BIAS} = 5.0\text{V}$  (new chip),  $I_{OUT} = 50\text{mA}$ ,  $V_{EN} = V_{IN}$ ,  $C_{IN} = 1\mu\text{F}$ ,  $C_{BIAS} = 4.7\mu\text{F}$ ,  $C_{SS} = 0.01\mu\text{F}$  (legacy chip), and  $C_{OUT} = 10\mu\text{F}$  (unless otherwise noted)

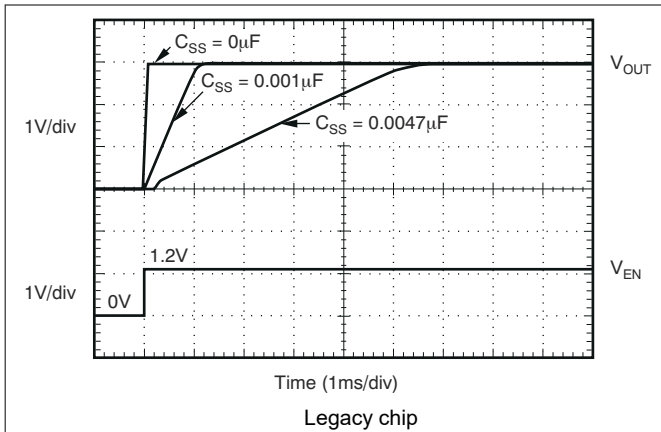

Figure 5-37. Turnon Response

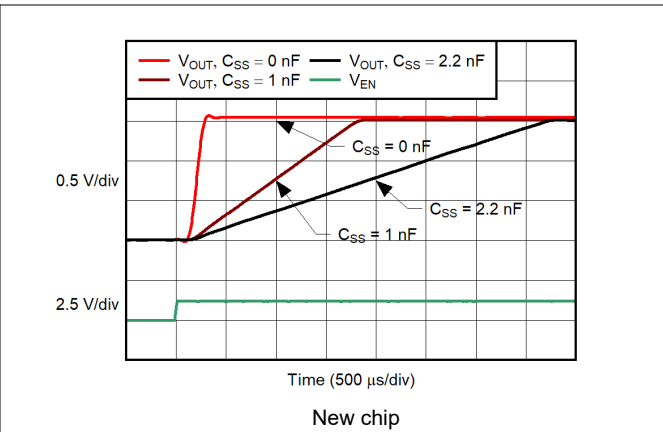

Figure 5-38. Turn-On Response

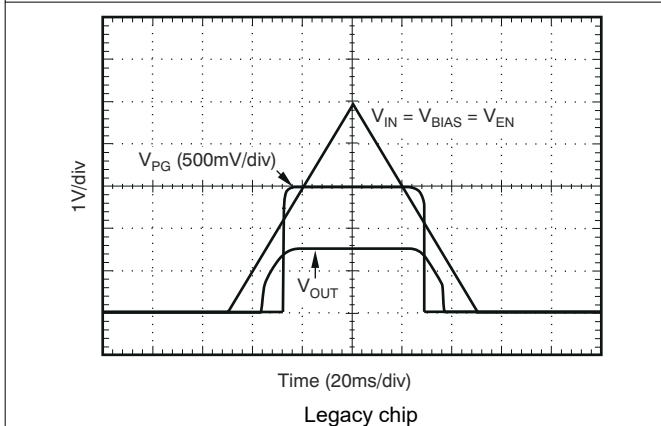

Figure 5-39. Power-Up, Power-Down

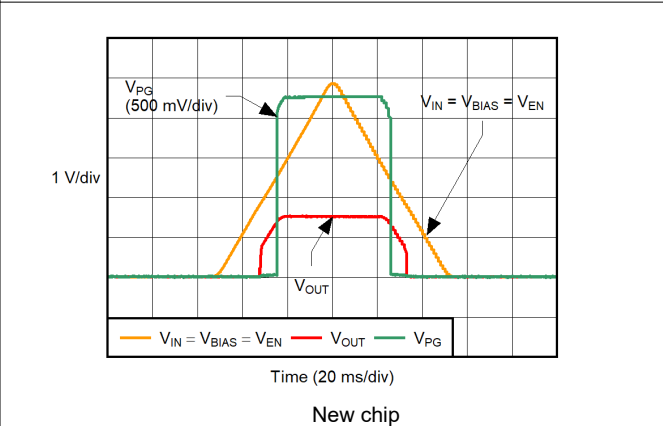

Figure 5-40. Power-Up, Power-Down

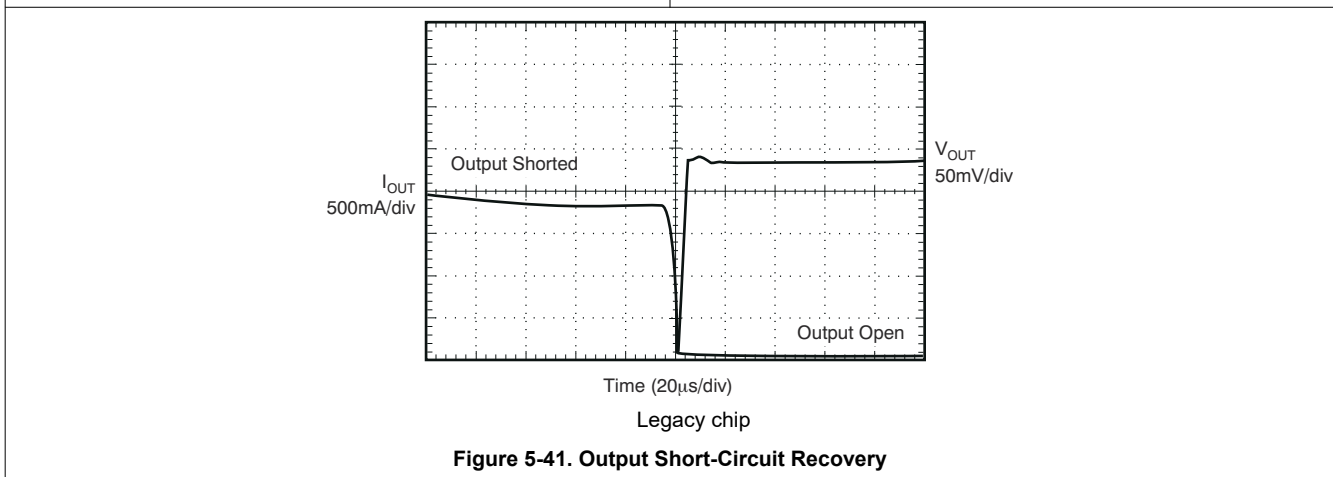

Figure 5-41. Output Short-Circuit Recovery

## 6 Detailed Description

### 6.1 Overview

The TPS742 belongs to a family of generation ultra-low dropout regulators that feature soft-start and tracking capabilities. These regulators use a low current bias input to power all internal control circuitry, allowing the NMOS pass transistor to regulate very low input and output voltages.

The use of an NMOS-pass transistor offers several critical advantages for many applications. Unlike a PMOS topology device, the output capacitor has little effect on loop stability. This architecture allows the TPS742 devices to be stable with any output capacitor  $\geq 2.2\mu\text{F}$ . Transient response is also superior to PMOS topologies, particularly for low  $V_{\text{IN}}$  applications.

The TPS742 devices feature a programmable voltage-controlled soft-start circuit that provides a smooth, monotonic start-up and limits start-up inrush currents that can be caused by large capacitive loads. A power-good (PG) output is available to allow supply monitoring and sequencing of other supplies. An enable (EN) pin with hysteresis and deglitch allows slow-ramping signals to be used for sequencing the device. The low  $V_{\text{IN}}$  and  $V_{\text{OUT}}$  capability allows for inexpensive, easy-to-design, and efficient linear regulation between the multiple supply voltages often present in processor intensive systems.

### 6.2 Functional Block Diagrams

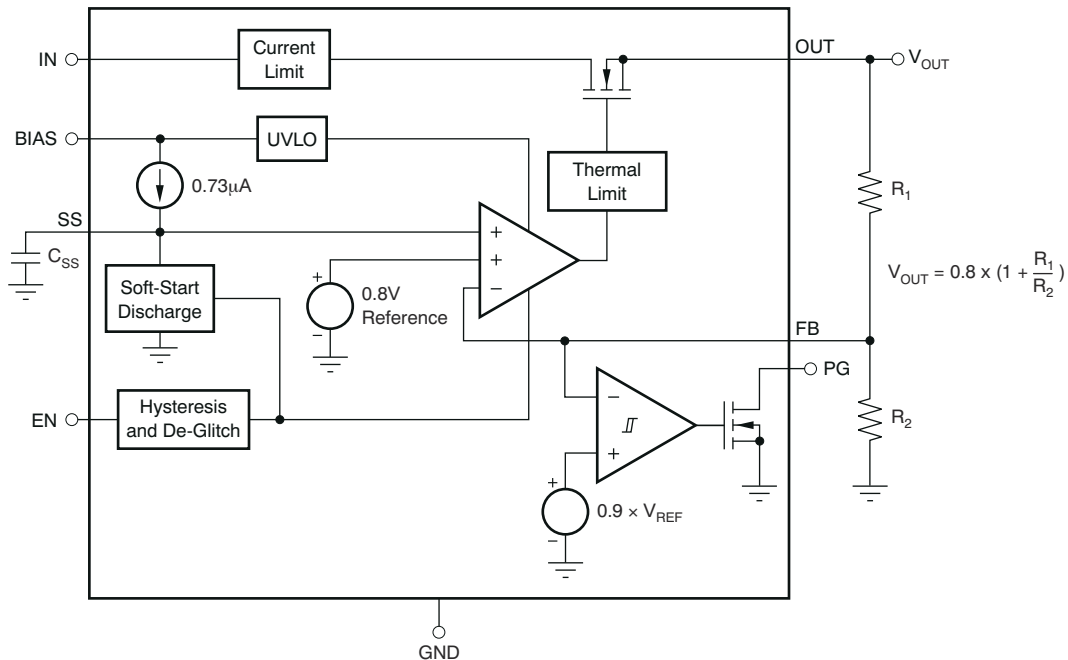

**Figure 6-1. Legacy Chip Functional Block Diagram**

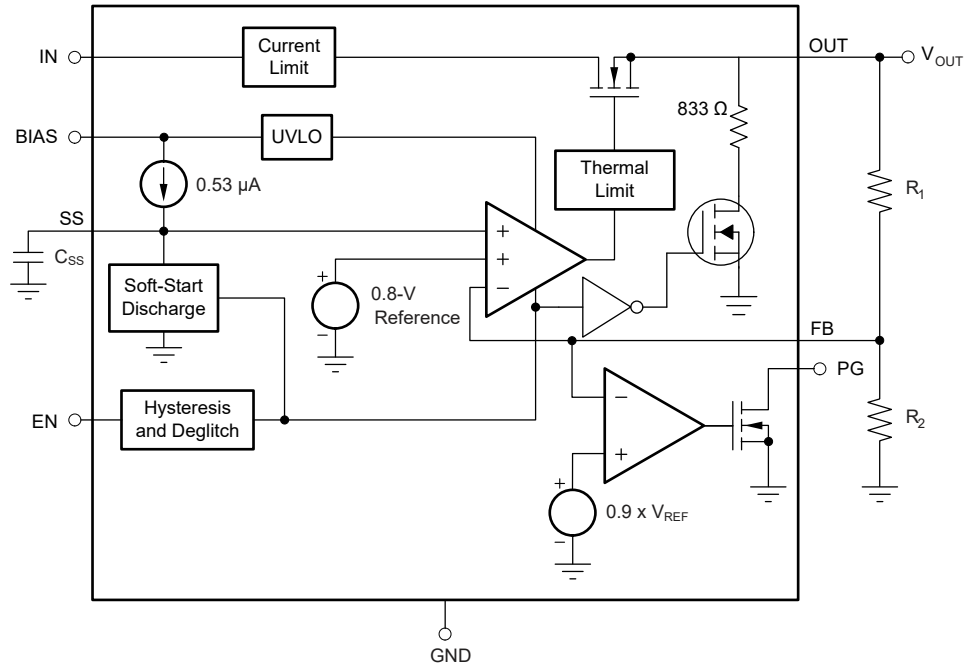

**Figure 6-2. New Chip Functional Block Diagram**

## 6.3 Feature Description

### 6.3.1 Enable and Shutdown

The enable (EN) pin is active high and is compatible with standard digital signaling levels.  $V_{EN}$  less than 0.4 V turns the regulator off and  $V_{EN}$  greater than 1.1 V turns the regulator on. Unlike many regulators, the enable circuitry has hysteresis and deglitching for use with relatively slow-ramping analog signals. This configuration allows the TPS742 devices to be enabled by connecting the output of another supply to the EN pin. The enable circuitry typically has 50 mV of hysteresis and a deglitch circuit to help avoid ON and OFF cycling because of small glitches in the  $V_{EN}$  signal.

The enable threshold is typically 0.8 V and varies with temperature and process variations. Temperature variation is approximately  $-1$  mV/°C; therefore, process variation accounts for most of the variation in the enable threshold. If precise turnon timing is required, then use a fast rise-time signal to enable the TPS742 devices.

If not used, EN can be connected to either IN or BIAS. If EN is connected to IN, then connect EN as closely as possible to the largest capacitance on the input to prevent voltage droops on that line from triggering the enable circuit.

### 6.3.2 Power-Good (VQFN Packages Only)

The power-good (PG) pin is an open-drain output and can be connected to any 5.5 V or lower rail through an external pullup resistor. This pin requires at least 1.1 V on  $V_{BIAS}$  to have a valid output. The PG output is high-impedance when  $V_{OUT}$  is greater than  $V_{IT} + V_{HYS}$ . If  $V_{OUT}$  drops below  $V_{IT}$  or if  $V_{BIAS}$  drops less than 1.9 V, the open-drain output turns on and pulls the PG output low. The PG pin also asserts when the device is disabled. The recommended operating condition of PG pin sink current is up to 1 mA, so the pullup resistor for PG must be in the range of 10 k $\Omega$  to 1 M $\Omega$ . PG is only provided on the VQFN packages. If output voltage monitoring is not needed, then the PG pin can be left floating.

### 6.3.3 Internal Current Limit

The TPS742 family features a factory-trimmed, accurate current limit that is flat over temperature and supply voltage. The current limit allows the device to supply surges of up to 1.8 A and maintain regulation. The current limit responds in about 10  $\mu$ s to reduce the current during a short circuit fault. Recovery from a short circuit condition is well-controlled and results in very little output overshoot when the load is removed. See [Figure 5-41](#) in the [Typical Characteristics](#) section for a graph of  $I_{OUT}$  versus  $V_{OUT}$  performance.

The internal current limit protection circuitry of the TPS742 family of devices is designed to protect against overload conditions. The circuitry is not intended to allow operation above the rated current of the device. Continuously running the TPS742 devices above the rated current degrades device reliability.

## 6.4 Device Functional Modes

### 6.4.1 Normal Operation

The device regulates to the nominal output voltage under the following conditions:

- The input voltage and bias voltage are both at least at the respective minimum specifications.
- The enable voltage has previously exceeded the enable rising threshold voltage and has not decreased below the enable falling threshold.
- The output current is less than the current limit.
- The device junction temperature is less than the maximum specified junction temperature.
- The device is not operating in dropout.

### 6.4.2 Dropout Operation

If the input voltage is lower than the nominal output voltage plus the specified dropout voltage, but all other conditions are met for normal operation, the device operates in dropout mode. In this condition, the output voltage is the same as the input voltage minus the dropout voltage. The transient performance of the device is significantly degraded because the pass transistor is in a triode state and no longer controls the current through the LDO. Line or load transients in dropout can result in large output voltage deviations.

### 6.4.3 Disabled

The device is disabled under the following conditions:

- The input or bias voltages are below the respective minimum specifications.
- The enable voltage is less than the enable falling threshold voltage or has not yet exceeded the enable rising threshold.
- The device junction temperature is greater than the thermal shutdown temperature.

Table 6-1 shows the conditions that lead to the different modes of operation.

**Table 6-1. Device Functional Mode Comparison**

OPERATING MODE	PARAMETER				
	$V_{IN}$	$V_{EN}$	$V_{BIAS}$	$I_{OUT}$	$T_J$
Normal mode	$V_{IN} > V_{OUT(nom)} + V_{DO}(V_{IN})$	$V_{EN} > V_{EN(high)}$	$V_{BIAS} \geq V_{OUT} + 1.4\text{ V}$	$I_{OUT} < I_{CL}$	$T_J < 125^\circ\text{C}$
Dropout mode	$V_{IN} < V_{OUT(nom)} + V_{DO}(V_{IN})$	$V_{EN} > V_{EN(high)}$	$V_{BIAS} < V_{OUT} + 1.4\text{ V}$	—	$T_J < 125^\circ\text{C}$
Disabled mode (any true condition disables the device)	$V_{IN} < V_{IN(min)}$	$V_{EN} < V_{EN(low)}$	$V_{BIAS} < V_{BIAS(min)}$	—	$T_J > 155^\circ\text{C}$

## 7 Application and Implementation

### Note

Information in the following applications sections is not part of the TI component specification, and TI does not warrant its accuracy or completeness. TI's customers are responsible for determining suitability of components for their purposes, as well as validating and testing their design implementation to confirm system functionality.

### 7.1 Application Information

#### 7.1.1 Input, Output, and Bias Capacitor Requirements

The TPS742 family does not require any output capacitor for stability. If an output capacitor is needed, the device is designed to be stable for all available types and values of output capacitance. The device is also stable with multiple capacitors in parallel, which can be of any type or value.

The capacitance required on the IN and BIAS pins is strongly dependent on the input supply source impedance. To counteract any inductance in the input, the minimum recommended capacitor for  $V_{IN}$  and  $V_{BIAS}$  is 1  $\mu$ F. If  $V_{IN}$  and  $V_{BIAS}$  are connected to the same supply, the recommended minimum capacitor for  $V_{BIAS}$  is 4.7  $\mu$ F. Use good quality, low ESR capacitors on the input; ceramic X5R and X7R capacitors are preferred. Place these capacitors as close to the pins as possible for optimum performance.

#### 7.1.2 Transient Response

The TPS742 family of devices were designed to have transient response within 5% for most applications without any output capacitor. In some cases, the transient response can be limited by the transient response of the input supply. This limitation is especially true in applications where the difference between the input and output is less than 300 mV. In this case, adding additional input capacitance improves the transient response much more than just adding additional output capacitance. With a solid input supply, adding additional output capacitance reduces undershoot and overshoot during a transient at the expense of a slightly longer  $V_{OUT}$  recovery time. See [Figure 5-35](#) in the *Typical Characteristics* section. Because the TPS742 devices are stable without an output capacitor, many applications can allow for little or no capacitance at the LDO output. For these applications, local bypass capacitance for the device under power can be sufficient to meet the transient requirements of the application. This design reduces the total solution cost by avoiding the need to use expensive high-value capacitors at the LDO output.

#### 7.1.3 Dropout Voltage

The TPS742 family of devices offers industry-leading dropout performance, making this family well-suited for high-current low  $V_{IN}$ /low  $V_{OUT}$  applications. The extremely low dropout of the TPS742 allows the device to be used in place of a DC/DC converter and still achieve good efficiency. This efficiency allows the user to rethink the power architecture of applications to achieve the smallest, simplest, and lowest cost solution.

There are two different specifications for dropout voltage with the TPS742 devices. The first specification (illustrated in [Figure 7-1](#)) is referred to as  $V_{IN}$  Dropout, and is for users who wish to apply an external bias voltage to achieve low dropout. This specification assumes that  $V_{BIAS}$  is at least 1.62 V above  $V_{OUT}$ , which is the case for  $V_{BIAS}$  when powered by a 3.3-V rail with 5% tolerance and with  $V_{OUT} = 1.5$  V. If  $V_{BIAS}$  is higher than  $3.3$  V  $\times$  0.95 or  $V_{OUT}$  is less than 1.5 V,  $V_{IN}$  dropout is less than specified.

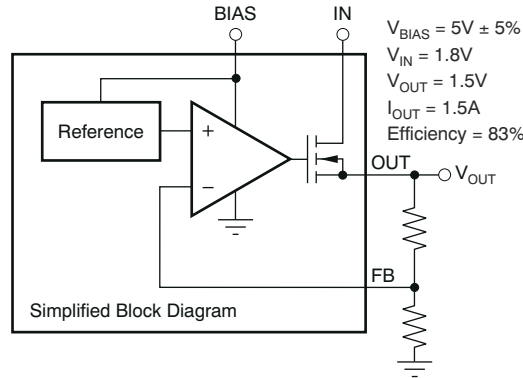

**Figure 7-1. Typical Application of the TPS742 Using an Auxiliary Bias Rail**

The second specification (shown in [Figure 7-2](#)) is referred to as  $V_{BIAS}$  Dropout, and is for users who wish to tie IN and BIAS together. This option allows the device to be used in applications where an auxiliary bias voltage is not available or low dropout is not required. Dropout is limited by BIAS in these applications because  $V_{BIAS}$  provides the gate drive to the pass transistor and therefore must be 1.4 V above  $V_{OUT}$ . Because of this usage, IN and BIAS tied together easily consume huge power. Pay attention not to exceed the power rating of the device package.

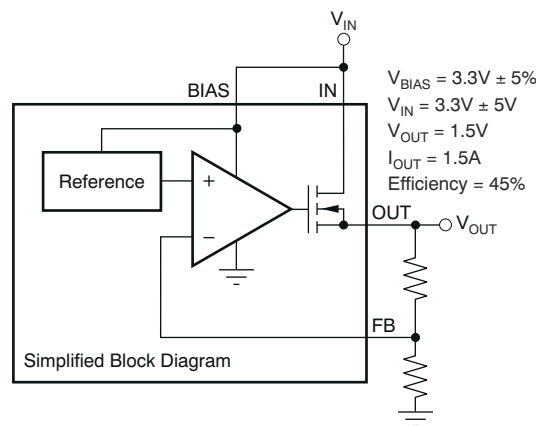

**Figure 7-2. Typical Application of the TPS742 Without an Auxiliary Bias**

### 7.1.4 Output Noise

The TPS742 devices provide low-output noise when a soft-start capacitor is used. When the device reaches the end of the soft-start cycle, the soft-start capacitor serves as a filter for the internal reference. By using a 0.001- $\mu$ F soft-start capacitor, the output noise is reduced by half and is typically 30  $\mu$ V<sub>RMS</sub> for a 1.2-V output (10 Hz to 100 kHz). Because most of the output noise is generated by the internal reference, the noise is a function of the set output voltage. The RMS noise with a 0.001- $\mu$ F soft-start capacitor is given in [Equation 1](#).

$$V_N (\mu V_{RMS}) = 25 \left( \frac{\mu V_{RMS}}{V} \right) \times V_{OUT} (V) \tag{1}$$

The low-output noise of the TPS742 makes the device a good choice for powering transceivers, PLLs, or other noise-sensitive circuitry.

### 7.1.5 Programmable Soft-Start

The TPS742 devices feature a programmable, monotonic, voltage-controlled soft start that is set with an external capacitor ( $C_{SS}$ ). This feature is important for many applications, because power-up initialization problems are eliminated when powering FPGAs, DSPs, or other processors. The controlled voltage ramp of the output also reduces peak inrush current during start-up, minimizing start-up transients to the input power bus.

To achieve a linear and monotonic soft-start, the TPS742 error amplifier tracks the voltage ramp of the external soft-start capacitor until the voltage exceeds the internal reference. The soft-start ramp time depends on the soft-start charging current ( $I_{SS}$ ), soft-start capacitance ( $C_{SS}$ ), and the internal reference voltage ( $V_{REF}$ ), and can be calculated using [Equation 2](#):

$$t_{SS} = \frac{(V_{REF} \times C_{SS})}{I_{SS}} \quad (2)$$

If large output capacitors are used, the device current limit ( $I_{CL}$ ) and the output capacitor can set the start-up time. In this case, the start-up time is given by [Equation 3](#):

$$t_{SSCL} = \frac{(V_{OUT(NOM)} \times C_{OUT})}{I_{CL(MIN)}} \quad (3)$$

$V_{OUT(NOM)}$  is the nominal set output voltage as set by the user,  $C_{OUT}$  is the output capacitance, and  $I_{CL(MIN)}$  is the minimum current limit for the device. In applications where monotonic start-up is required, the soft-start time given by [Equation 2](#) must be set to be greater than [Equation 3](#).

The maximum recommended soft-start capacitor is 0.015 $\mu$ F. Larger soft-start capacitors can be used and do not damage the device; however, the soft-start capacitor discharge circuit is not always able to fully discharge the soft-start capacitor when enabled. Soft-start capacitors larger than 0.015 $\mu$ F can be a problem in applications where the user must rapidly pulse the enable pin and still requires the device to soft-start from ground.  $C_{SS}$  must be low-leakage; X7R, X5R, or C0G dielectric materials are preferred. See [Table 7-1](#) for suggested soft-start capacitor values.

**Table 7-1. Standard Capacitor Values for Programming the Soft-Start Time**

$C_{SS}$	SOFT-START TIME <sup>(1)</sup> (Legacy Chip)	SOFT-START TIME <sup>(2)</sup> (New Chip)
Open	0.1ms	0.25ms
470pF	0.5ms	0.7ms
1000pF	1ms	1.5ms
4700pF	5ms	7ms
0.01 $\mu$ F	10ms	15ms
0.015 $\mu$ F	16ms	22.6ms

(1) See [Equation 4](#).

(2) See [Equation 5](#).

$$t_{SS}(s) = \frac{V_{REF} \times C_{SS}}{I_{SS}} = \frac{0.8V \times C_{SS}(F)}{0.73\mu A} \quad (4)$$

$$t_{SS}(s) = 0.8 \times C_{SS}(F) \div 530nA \quad (5)$$

where:

- $t_{SS}(s)$  = Soft-start time in seconds

### 7.1.6 Sequencing Requirements

The device can have  $V_{IN}$ ,  $V_{BIAS}$ , and  $V_{EN}$  sequenced in any order without causing damage to the device. However, for the soft-start function to work as intended, certain sequencing rules must be applied. Enabling the device after  $V_{IN}$  and  $V_{BIAS}$  are present is preferred, and can be accomplished using a digital output from a processor or supply supervisor. An analog signal from an external RC circuit, as shown in Figure 7-3, can also be used as long as the delay time is long enough for  $V_{IN}$  and  $V_{BIAS}$  to be present.

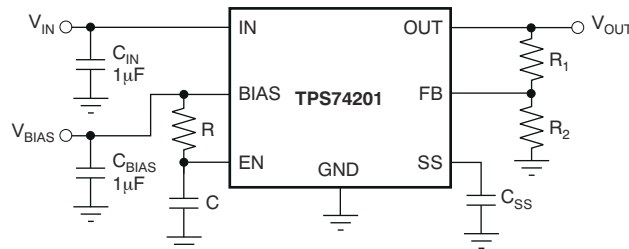

**Figure 7-3. Soft-Start Delay Using an RC Circuit on Enable**

If a signal is not available to enable the device after  $V_{IN}$  and  $V_{BIAS}$ , simply connecting  $EN$  to  $IN$  is acceptable for most applications as long as  $V_{IN}$  is greater than 1.1 V and the ramp rate of  $V_{IN}$  and  $V_{BIAS}$  is faster than the set soft-start ramp rate. If the ramp rate of the input sources is slower than the set soft-start time, the output tracks the slower supply minus the dropout voltage until the set output voltage is reached. If  $EN$  is connected to  $BIAS$ , the device does soft-start as programmed provided that  $V_{IN}$  is present before  $V_{BIAS}$ . If  $V_{BIAS}$  and  $V_{EN}$  are present before  $V_{IN}$  is applied and the set soft-start time has expired then  $V_{OUT}$  tracks  $V_{IN}$ .

#### Note

When  $V_{BIAS}$  and  $V_{EN}$  are present and  $V_{IN}$  is not supplied, this device outputs approximately 50  $\mu A$  of current from  $OUT$ . Although this condition does not cause any damage to the device, the output current can charge up the  $OUT$  node if total resistance between  $OUT$  and  $GND$  (including external feedback resistors) is greater than 10 k $\Omega$ .

## 7.2 Typical Applications

Figure 7-4 is a typical application circuit for the TPS742 adjustable output device.

$R_1$  and  $R_2$  can be calculated for any output voltage using the formula shown in Figure 7-4. See Table 7-2 for sample resistor values of common output voltages. To achieve the maximum accuracy specifications,  $R_2$  must be  $\leq 4.99$  k $\Omega$ .

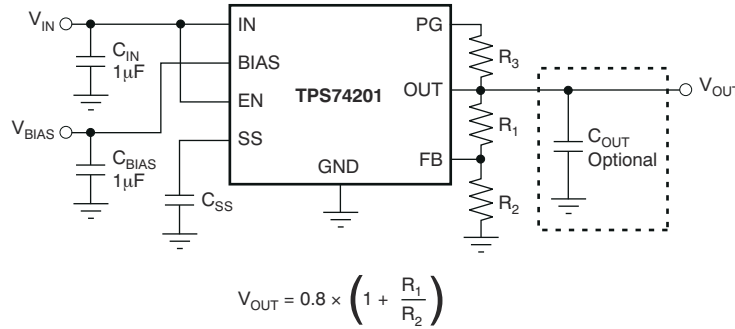

**Figure 7-4. Typical Application Circuit for the TPS742**

**Table 7-2. Standard 1% Resistor Values for Programming the Output Voltage  
(See Equation 6)**

$R_1$ (k $\Omega$ )	$R_2$ (k $\Omega$ )	$V_{OUT}$ (V)
Short	Open	0.8
0.619	4.99	0.9
1.13	4.53	1
1.37	4.42	1.05
1.87	4.99	1.1
2.49	4.99	1.2
4.12	4.75	1.5
3.57	2.87	1.8
3.57	1.69	2.5
3.57	1.15	3.3

$$V_{OUT} = 0.8 \times (1 + R1/R2) \tag{6}$$

### Note

When  $V_{BIAS}$  and  $V_{EN}$  are present and  $V_{IN}$  is not supplied, this device outputs approximately 50  $\mu$ A of current from OUT. Although this condition does not cause any damage to the device, the output current can charge up the OUT node if total resistance between OUT and GND (including external feedback resistors) is greater than 10 k $\Omega$ .

### 7.2.1 Design Requirements

The design goals are  $V_{IN} = 1.8$  V,  $V_{OUT} = 1.5$  V, and  $I_{OUT} = 1$  A (maximum). The design optimizes transient response and meets a 1-ms start-up time with a start-up dominated by the soft-start feature. The input supply comes from a supply on the same circuit board. The available system rails for  $V_{BIAS}$  are 2.7 V, 3.3 V, and 5 V.

The design space consists of  $C_{IN}$ ,  $C_{OUT}$ ,  $C_{BIAS}$ ,  $C_{SS}$ ,  $V_{BIAS}$ ,  $R_1$ ,  $R_2$ , and  $R_3$ , and the circuit is from Figure 7-4.

This example uses a  $V_{IN}$  of 1.8 V, with a  $V_{BIAS}$  of 2.5 V.

### 7.2.2 Detailed Design Procedure

This is assuming the table for the standard capacitor values is put back in as [Table 6-1](#).

Using [Table 7-2](#), R1 is selected to be 4.12 k $\Omega$  for  $V_{OUT} = 1.5\text{ V}$  and R2 is 4.75 k $\Omega$ . Using [Table 6-1](#),  $C_{SS}$  is 1000 pF for a 1-ms typical start-up time. For optimal performance, 5-V rail for a Bias supply is used. And R3 of 100 k $\Omega$  is selected as the PG bus is used by other devices with additional 100-k $\Omega$  pullup resistors.

A  $C_{IN}$  of 10  $\mu\text{F}$  is used for better transient performance on the input supply, a  $C_{BIAS}$  of 1  $\mu\text{F}$  is used to verify that the Bias supply is solid, and a  $C_{OUT}$  of 1  $\mu\text{F}$  is used to provide some local capacitance on the output.

### 7.2.3 Application Curves

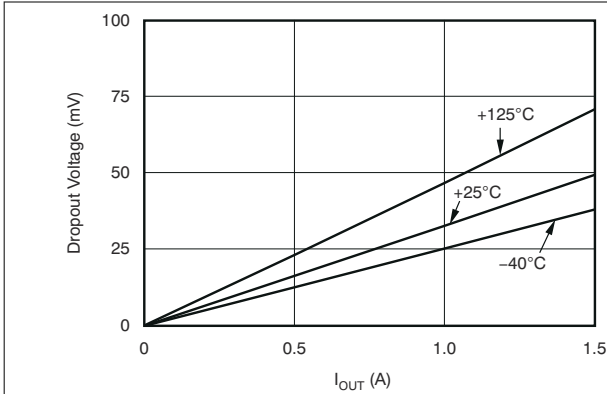

**Figure 7-5.  $V_{IN}$  Dropout Voltage vs  $I_{OUT}$  and Temperature ( $T_J$ )**

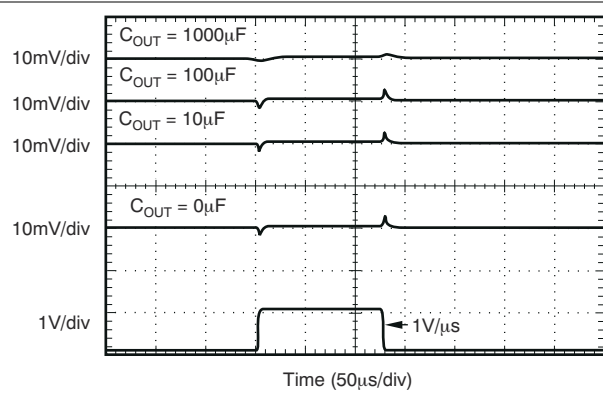

**Figure 7-6.  $V_{BIAS}$  Line Transient (1.5A)**

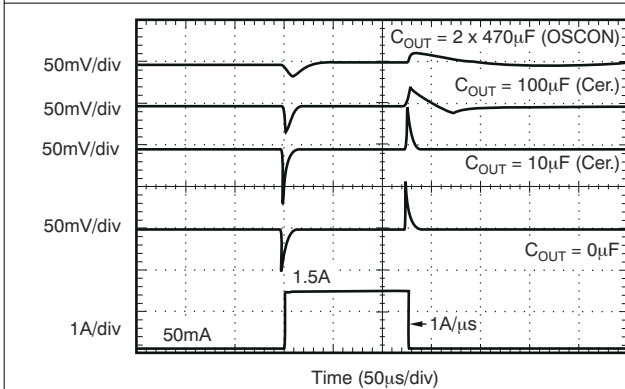

**Figure 7-7. Output Load Transient Response**

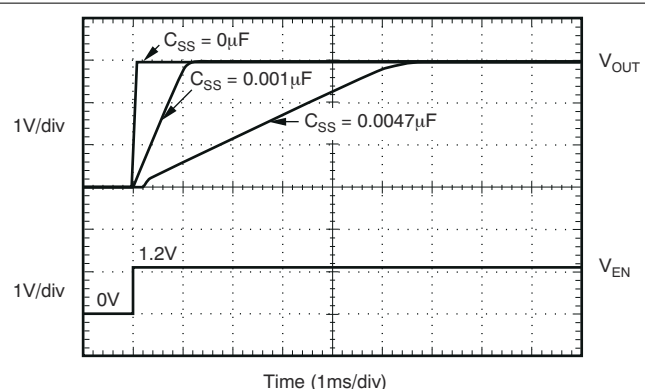

**Figure 7-8. Turnon Response**

## 7.3 Power Supply Recommendations

The TPS742 devices are designed to operate from an input voltage from 1.1V to 5.5V, provided the bias rail is at least 1.4V higher than the input supply. The bias rail and the input supply must both provide adequate headroom and current for the device to operate normally.

Connect a low-output impedance power supply directly to the IN pin of the TPS742 devices. This supply must have at least 1  $\mu\text{F}$  of capacitance near the IN pin for stability. A supply with similar requirements must also be connected directly to the bias rail with a separate 1  $\mu\text{F}$  or larger capacitor.

If the IN pin is tied to the bias pin, a minimum 4.7  $\mu\text{F}$  of capacitance is needed for stability.

To increase the overall PSRR of the solution at higher frequencies, use a pi-filter or ferrite bead before the input capacitor.

## 7.4 Layout

### 7.4.1 Layout Guidelines

An optimal layout can greatly improve transient performance, PSRR, and noise. To minimize the voltage droop on the input of the device during load transients, connect the capacitance on IN and BIAS as close as possible to the device. This capacitance also minimizes the effects of parasitic inductance and resistance of the input source and can therefore improve stability. To achieve optimal transient performance and accuracy, connect the top side of R<sub>1</sub> in [Figure 7-4](#) as close as possible to the load. If BIAS is connected to IN, TI recommends connecting BIAS as close to the sense point of the input supply as possible. This connection minimizes the voltage droop on BIAS during transient conditions and can improve the turnon response.

#### 7.4.1.1 Thermal Protection

Thermal protection disables the output when the junction temperature rises to approximately 160°C, allowing the device to cool. When the junction temperature cools to approximately 140°C, the output circuitry is enabled. Depending on power dissipation, thermal resistance, and ambient temperature the thermal protection circuit can cycle ON and OFF. This cycling limits the dissipation of the regulator, protecting the regulator from damage as a result of overheating.

Activation of the thermal protection circuit indicates excessive power dissipation or inadequate heatsinking. For reliable operation, limit junction temperature to 125°C maximum. To estimate the margin of safety in a complete design (including heatsink), increase the ambient temperature until thermal protection is triggered; use worst-case loads and signal conditions. For good reliability, thermal protection must trigger at least 40°C above the maximum expected ambient condition of the application. This condition produces a worst-case junction temperature of 125°C at the highest expected ambient temperature and worst-case load.

The internal protection circuitry of the TPS742 devices is designed to protect against overload conditions. This circuitry is not intended to replace proper heatsinking. Continuously running the TPS742 devices into thermal shutdown degrades device reliability.

#### 7.4.1.2 Thermal Considerations

Using the thermal metrics  $\Psi_{JT}$  and  $\Psi_{JB}$ , in the [Thermal Information](#) table, the junction temperature can be estimated with corresponding formulas (given in [Equation 7](#)). For backwards compatibility, an older  $\theta_{JC, Top}$  parameter is listed as well.

$$\begin{aligned} \Psi_{JT}: T_J &= T_T + \Psi_{JT} \cdot P_D \\ \Psi_{JB}: T_J &= T_B + \Psi_{JB} \cdot P_D \end{aligned} \tag{7}$$

where

- P<sub>D</sub> is the power dissipation given by  $P_D = (V_{IN} - V_{OUT}) \times I_{OUT}$
- T<sub>T</sub> is the temperature at the center-top of the IC package
- T<sub>B</sub> is the PCB temperature measured 1mm away from the IC package *on the PCB surface* (as [Figure 7-9](#) shows).

---

#### Note

Both T<sub>T</sub> and T<sub>B</sub> can be measured on actual application boards using a thermo-gun (an infrared thermometer).

---

For more information about measuring T<sub>T</sub> and T<sub>B</sub>, see the [Using New Thermal Metrics](#) application note, available for download at [www.ti.com](http://www.ti.com).

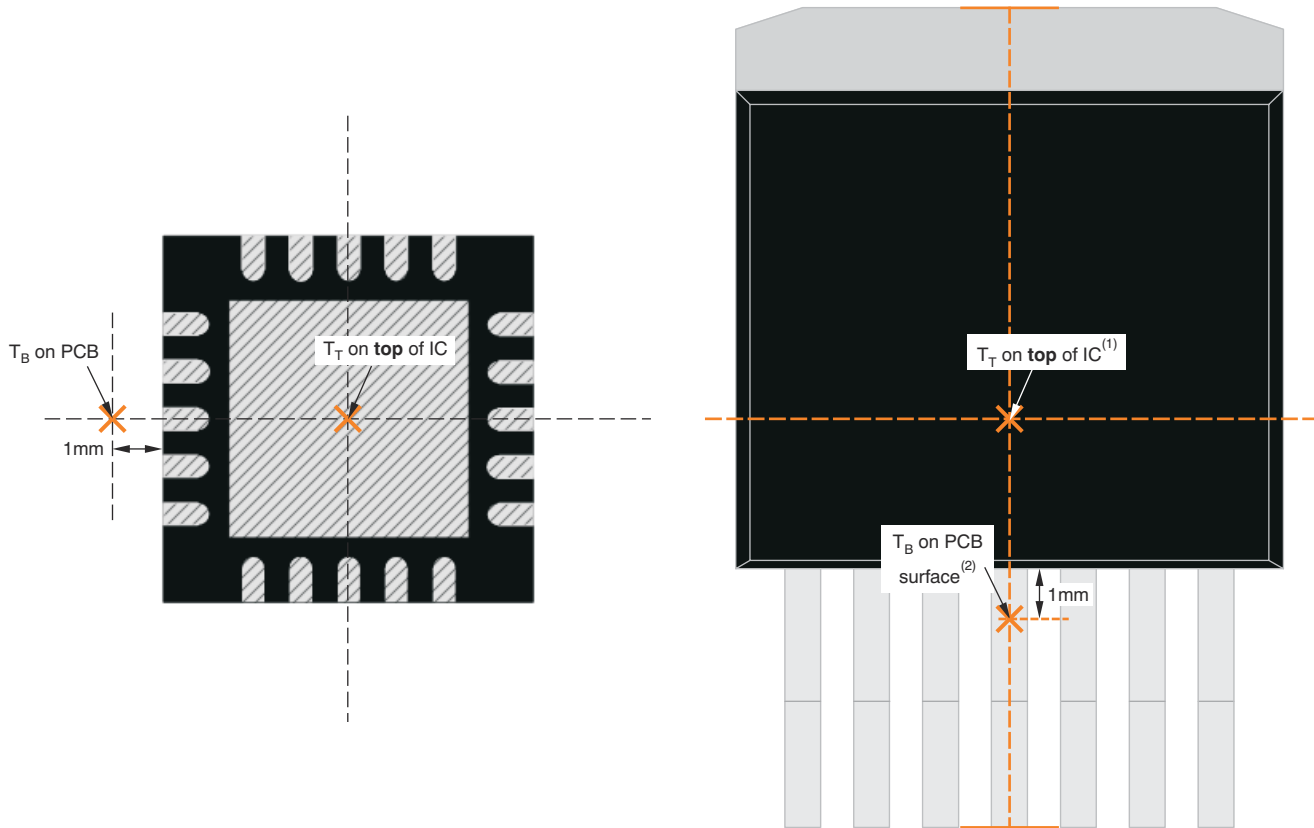

(a) Example RGW (QFN) Package Measurement

(b) Example KTW (DDPAK) Package Measurement

- A.  $T_T$  is measured at the center of both the X- and Y-dimensional axes.
- B.  $T_B$  is measured **below** the package lead **on the PCB surface**.

**Figure 7-9. Measuring Points for  $T_T$  and  $T_B$**

Compared with  $\theta_{JA}$ , the new thermal metrics  $\Psi_{JT}$  and  $\Psi_{JB}$  are less independent of board size, but the metrics do have a small dependency. Figure 7-10 shows characteristic performance of  $\Psi_{JT}$  and  $\Psi_{JB}$  versus board size.

Looking at Figure 7-10, the RGW package thermal performance has negligible dependency on board size. The KTW package, however, does have a measurable dependency on board size. This dependency exists because the package shape is not point-symmetric to an IC center. In the KTW package, for example (see Figure 7-9), silicon is not beneath the measuring point of  $T_T$ , which is the center of the X and Y dimension, so that  $\Psi_{JT}$  has a dependency. Also, because of that non-point-symmetry, device heat distribution on the PCB is not point-symmetric, either, so that  $\Psi_{JB}$  has a dependency.

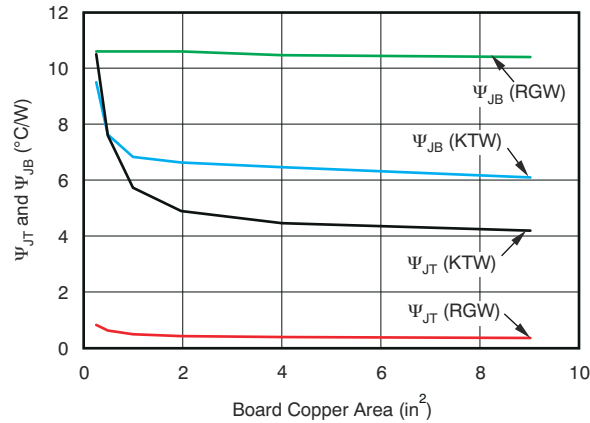

**Figure 7-10.  $\Psi_{JT}$  and  $\Psi_{JB}$  vs Board Size**

For a more detailed discussion of why TI does not recommend using  $\theta_{JC,Top}$  to determine thermal characteristics, refer to the [Using New Thermal Metrics application note](#), available for download at [www.ti.com](http://www.ti.com). Also, refer to the [IC Package Thermal Metrics application note](#) (also available on the TI website) for further information.

**7.4.2 Layout Example**

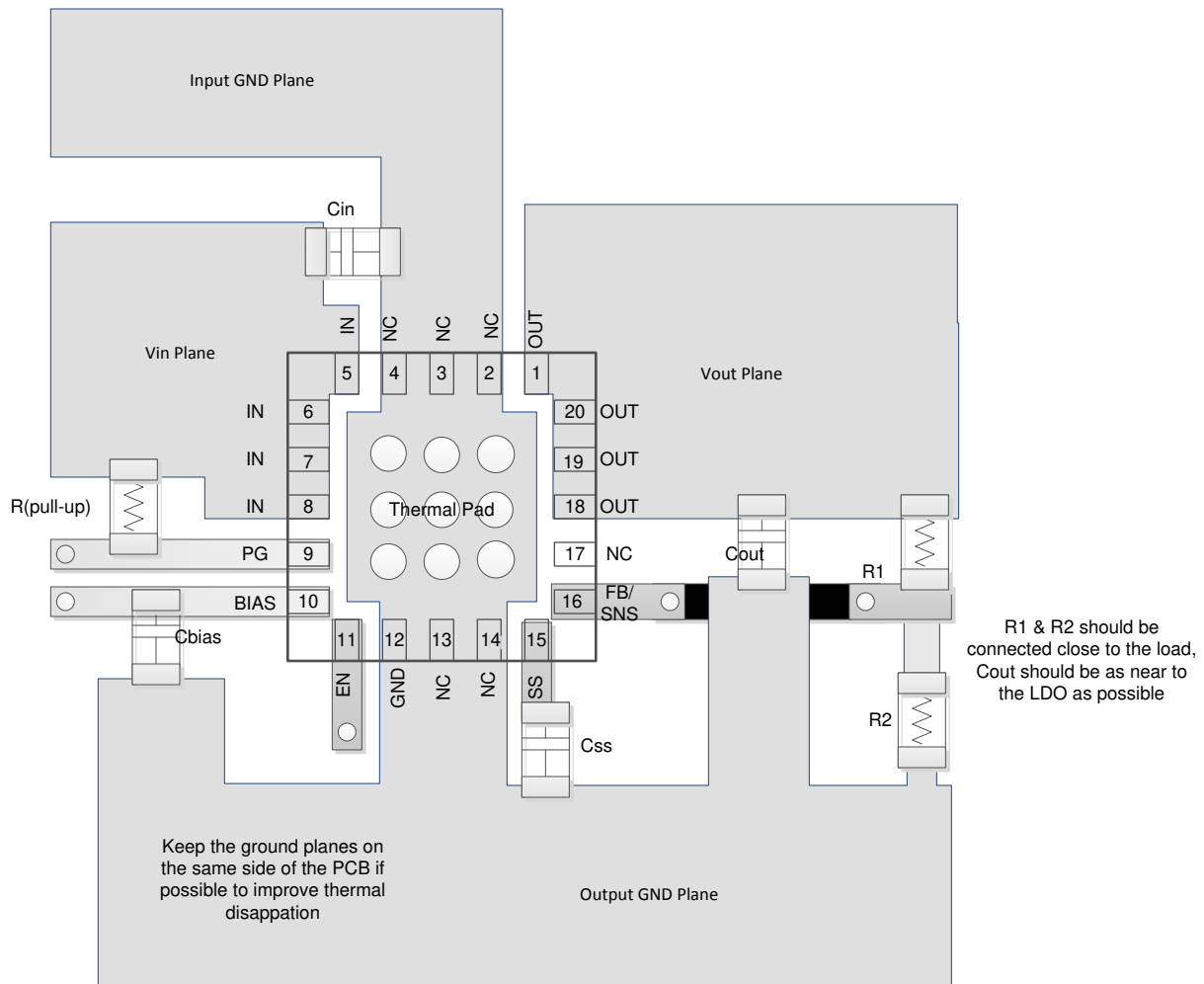

**Figure 7-11. Layout Schematic (VQFN Packages)**

## 8 Device and Documentation Support

### 8.1 Device Support

#### 8.1.1 Development Support

##### 8.1.1.1 Evaluation Modules

An evaluation module (EVM) is available to assist in the initial circuit performance evaluation using the TPS744. The [TPS74201EVM-118 evaluation module](#) (and [related user guide](#)) can be requested at the Texas Instruments website through the product folders or purchased directly from the [TI eStore](#).

##### 8.1.1.2 Spice Models

Computer simulation of circuit performance using SPICE is often useful when analyzing the performance of analog circuits and systems. A SPICE model for the TPS744 is available through the product folders under *Tools & Software*.

### 8.2 Documentation Support

#### 8.2.1 Related Documentation

For related documentation see the following:

- Texas Instruments, [6A Current-Sharing Dual LDO design guide](#)
- Texas Instruments, [Using New Thermal Metrics application note](#)

#### 8.2.2 Device Nomenclature

**Table 8-1. Device Nomenclature**

PRODUCT <sup>(1)</sup>	V <sub>OUT</sub>
TPS74201yyyzM3	<p><b>yyy</b> is the package designator.</p> <p><b>z</b> is the package quantity.</p> <p><b>M3</b> is a suffix designator for devices that only use the latest manufacturing flow (CSO: RFB). Devices without this suffix can ship with the legacy chip (CSO: DLN) or the new chip (CSO: RFB). The reel packaging label provides CSO information to distinguish which chip is being used. Device performance for new and legacy chips is denoted throughout the document.</p>

(1) For the most current package and ordering information see the Package Option Addendum at the end of this document, or visit the device product folder on [www.ti.com](#).

### 8.3 Receiving Notification of Documentation Updates

To receive notification of documentation updates, navigate to the device product folder on [ti.com](#). Click on *Notifications* to register and receive a weekly digest of any product information that has changed. For change details, review the revision history included in any revised document.

### 8.4 Support Resources

[TI E2E™ support forums](#) are an engineer's go-to source for fast, verified answers and design help — straight from the experts. Search existing answers or ask your own question to get the quick design help you need.

Linked content is provided "AS IS" by the respective contributors. They do not constitute TI specifications and do not necessarily reflect TI's views; see TI's [Terms of Use](#).

### 8.5 Trademarks

TI E2E™ is a trademark of Texas Instruments.  
All trademarks are the property of their respective owners.

## 8.6 Electrostatic Discharge Caution



This integrated circuit can be damaged by ESD. Texas Instruments recommends that all integrated circuits be handled with appropriate precautions. Failure to observe proper handling and installation procedures can cause damage.

ESD damage can range from subtle performance degradation to complete device failure. Precision integrated circuits may be more susceptible to damage because very small parametric changes could cause the device not to meet its published specifications.

## 8.7 Glossary

[TI Glossary](#) This glossary lists and explains terms, acronyms, and definitions.

## 9 Revision History

NOTE: Page numbers for previous revisions may differ from page numbers in the current version.

Changes from Revision O (October 2024) to Revision P (February 2025)	Page
• Added curves for the new chip.....	8
• Added new chip information to <i>Standard Capacitor Values for Programming the Soft-Start Time</i> table.....	21

Changes from Revision N (November 2016) to Revision O (October 2024)	Page
• Updated the numbering format for tables, figures, and cross-references throughout the document.....	1
• Changed entire document to align with current family format.....	1
• Added M3 devices to document.....	1
• Added device verbiage throughout document to differentiate legacy silicon and new silicon information.....	1
• Changed <i>Device Information</i> table to <i>Package Information</i> Removed last sentence .....	1

## 10 Mechanical, Packaging, and Orderable Information

The following pages include mechanical, packaging, and orderable information. This information is the most current data available for the designated devices. This data is subject to change without notice and revision of this document. For browser-based versions of this data sheet, refer to the left-hand navigation.

**PACKAGING INFORMATION**

Orderable part number	Status (1)	Material type (2)	Package   Pins	Package qty   Carrier	RoHS (3)	Lead finish/ Ball material (4)	MSL rating/ Peak reflow (5)	Op temp (°C)	Part marking (6)
<a href="#">TPS74201KTWR</a>	Active	Production	DDPAK/TO-263 (KTW)   7	500   LARGE T&R	Yes	SN	Level-3-245C-168 HR	-40 to 125	TPS74201
TPS74201KTWR.A	Active	Production	DDPAK/TO-263 (KTW)   7	500   LARGE T&R	Yes	SN	Level-3-245C-168 HR	-40 to 125	TPS74201
TPS74201KTWRG3	Active	Production	DDPAK/TO-263 (KTW)   7	500   LARGE T&R	Yes	SN	Level-3-245C-168 HR	-40 to 125	TPS74201
<a href="#">TPS74201RGRR</a>	Active	Production	VQFN (RGR)   20	3000   LARGE T&R	Yes	NIPDAU	Level-2-260C-1 YEAR	-40 to 125	12JA
TPS74201RGRR.A	Active	Production	VQFN (RGR)   20	3000   LARGE T&R	Yes	NIPDAU	Level-2-260C-1 YEAR	-40 to 125	12JA
<a href="#">TPS74201RGRT</a>	Obsolete	Production	VQFN (RGR)   20	-	-	Call TI	Call TI	-40 to 125	12JA
<a href="#">TPS74201RGWR</a>	Active	Production	VQFN (RGW)   20	3000   LARGE T&R	Yes	NIPDAU	Level-2-260C-1 YEAR	-40 to 125	TPS 74201
TPS74201RGWR.A	Active	Production	VQFN (RGW)   20	3000   LARGE T&R	Yes	NIPDAU	Level-2-260C-1 YEAR	-40 to 125	TPS 74201
TPS74201RGWRG4	Active	Production	VQFN (RGW)   20	3000   LARGE T&R	Yes	NIPDAU	Level-2-260C-1 YEAR	-40 to 125	TPS 74201
<a href="#">TPS74201RGWRM3</a>	Active	Production	VQFN (RGW)   20	3000   LARGE T&R	Yes	NIPDAU	Level-2-260C-1 YEAR	-40 to 125	TPS 74201
TPS74201RGWRM3.A	Active	Production	VQFN (RGW)   20	3000   LARGE T&R	Yes	NIPDAU	Level-2-260C-1 YEAR	-40 to 125	TPS 74201
<a href="#">TPS74201RGWT</a>	Active	Production	VQFN (RGW)   20	250   SMALL T&R	Yes	NIPDAU	Level-2-260C-1 YEAR	-40 to 125	TPS 74201
TPS74201RGWT.A	Active	Production	VQFN (RGW)   20	250   SMALL T&R	Yes	NIPDAU	Level-2-260C-1 YEAR	-40 to 125	TPS 74201
TPS74201RGWTG4	Active	Production	VQFN (RGW)   20	250   SMALL T&R	Yes	NIPDAU	Level-2-260C-1 YEAR	-40 to 125	TPS 74201

(1) **Status:** For more details on status, see our [product life cycle](#).

(2) **Material type:** When designated, preproduction parts are prototypes/experimental devices, and are not yet approved or released for full production. Testing and final process, including without limitation quality assurance, reliability performance testing, and/or process qualification, may not yet be complete, and this item is subject to further changes or possible discontinuation. If available for ordering, purchases will be subject to an additional waiver at checkout, and are intended for early internal evaluation purposes only. These items are sold without warranties of any kind.

(3) **RoHS values:** Yes, No, RoHS Exempt. See the [TI RoHS Statement](#) for additional information and value definition.

(4) **Lead finish/Ball material:** Parts may have multiple material finish options. Finish options are separated by a vertical ruled line. Lead finish/Ball material values may wrap to two lines if the finish value exceeds the maximum column width.

(5) **MSL rating/Peak reflow:** The moisture sensitivity level ratings and peak solder (reflow) temperatures. In the event that a part has multiple moisture sensitivity ratings, only the lowest level per JEDEC standards is shown. Refer to the shipping label for the actual reflow temperature that will be used to mount the part to the printed circuit board.

(6) **Part marking:** There may be an additional marking, which relates to the logo, the lot trace code information, or the environmental category of the part.

Multiple part markings will be inside parentheses. Only one part marking contained in parentheses and separated by a "~" will appear on a part. If a line is indented then it is a continuation of the previous line and the two combined represent the entire part marking for that device.

**Important Information and Disclaimer:** The information provided on this page represents TI's knowledge and belief as of the date that it is provided. TI bases its knowledge and belief on information provided by third parties, and makes no representation or warranty as to the accuracy of such information. Efforts are underway to better integrate information from third parties. TI has taken and continues to take reasonable steps to provide representative and accurate information but may not have conducted destructive testing or chemical analysis on incoming materials and chemicals. TI and TI suppliers consider certain information to be proprietary, and thus CAS numbers and other limited information may not be available for release.

In no event shall TI's liability arising out of such information exceed the total purchase price of the TI part(s) at issue in this document sold by TI to Customer on an annual basis.

**TAPE AND REEL INFORMATION**

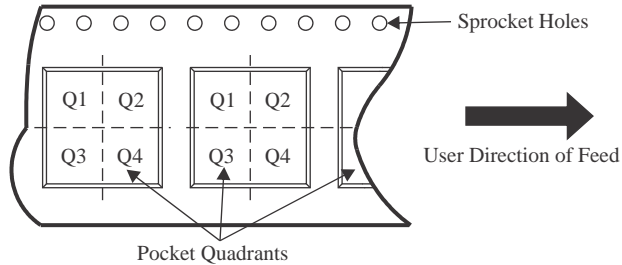
**QUADRANT ASSIGNMENTS FOR PIN 1 ORIENTATION IN TAPE**

\*All dimensions are nominal

Device	Package Type	Package Drawing	Pins	SPQ	Reel Diameter (mm)	Reel Width W1 (mm)	A0 (mm)	B0 (mm)	K0 (mm)	P1 (mm)	W (mm)	Pin1 Quadrant
TPS74201KTWR	DDPAK/TO-263	KTW	7	500	330.0	24.4	10.6	15.8	4.9	16.0	24.0	Q2
TPS74201RGRR	VQFN	RGR	20	3000	330.0	12.4	3.8	3.8	1.1	8.0	12.0	Q1
TPS74201RGWR	VQFN	RGW	20	3000	330.0	12.4	5.3	5.3	1.1	8.0	12.0	Q2
TPS74201RGWRM3	VQFN	RGW	20	3000	330.0	12.4	5.3	5.3	1.1	8.0	12.0	Q2
TPS74201RGWT	VQFN	RGW	20	250	180.0	12.4	5.3	5.3	1.1	8.0	12.0	Q2

**TAPE AND REEL BOX DIMENSIONS**

\*All dimensions are nominal

Device	Package Type	Package Drawing	Pins	SPQ	Length (mm)	Width (mm)	Height (mm)
TPS74201KTWR	DDPAK/TO-263	KTW	7	500	356.0	356.0	45.0
TPS74201RGRR	VQFN	RGR	20	3000	338.0	355.0	35.0
TPS74201RGWR	VQFN	RGW	20	3000	367.0	367.0	35.0
TPS74201RGWRM3	VQFN	RGW	20	3000	367.0	367.0	35.0
TPS74201RGWT	VQFN	RGW	20	250	210.0	185.0	35.0

## GENERIC PACKAGE VIEW

**RGW 20**

**VQFN - 1 mm max height**

5 x 5, 0.65 mm pitch

PLASTIC QUAD FLATPACK - NO LEAD

This image is a representation of the package family, actual package may vary.  
Refer to the product data sheet for package details.

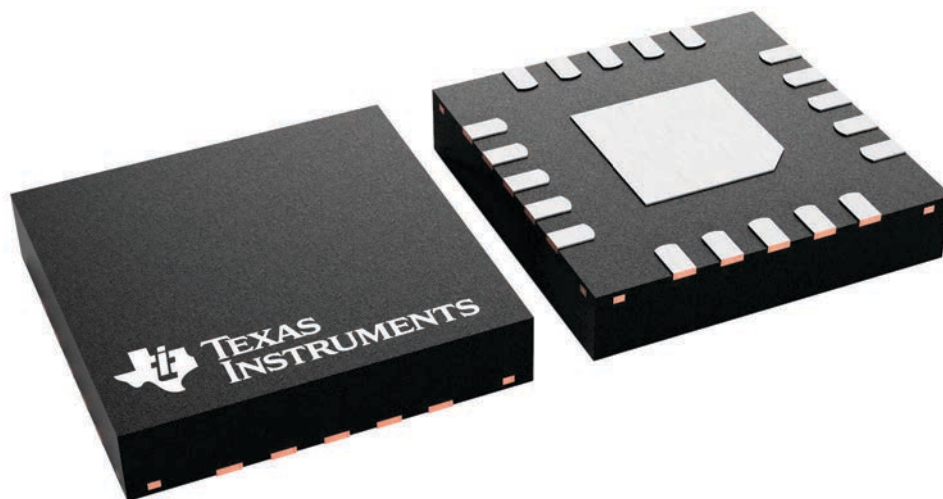

4227157/A



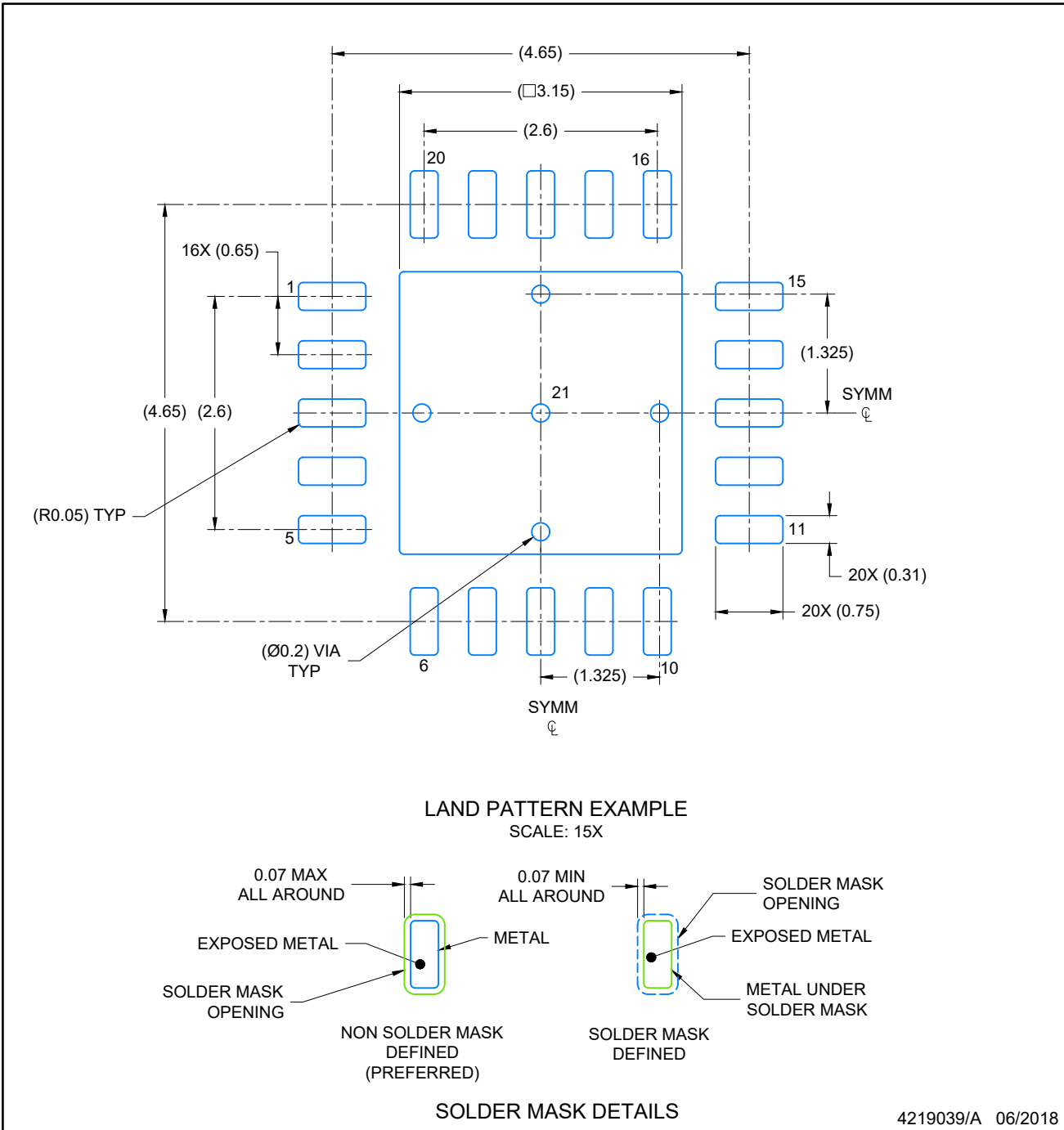

4219039/A 06/2018

NOTES: (continued)

4. This package is designed to be soldered to a thermal pad on the board. For more information, see Texas Instruments literature number SLUA271 ([www.ti.com/lit/sluea271](http://www.ti.com/lit/sluea271)).
5. Vias are optional depending on application, refer to device data sheet. If any vias are implemented, refer to their locations shown on this view. It is recommended that vias under paste be filled, plugged or tented.

# EXAMPLE STENCIL DESIGN

VQFN - 1 mm max height

RGW0020A

PLASTIC QUAD FLATPACK-NO LEAD

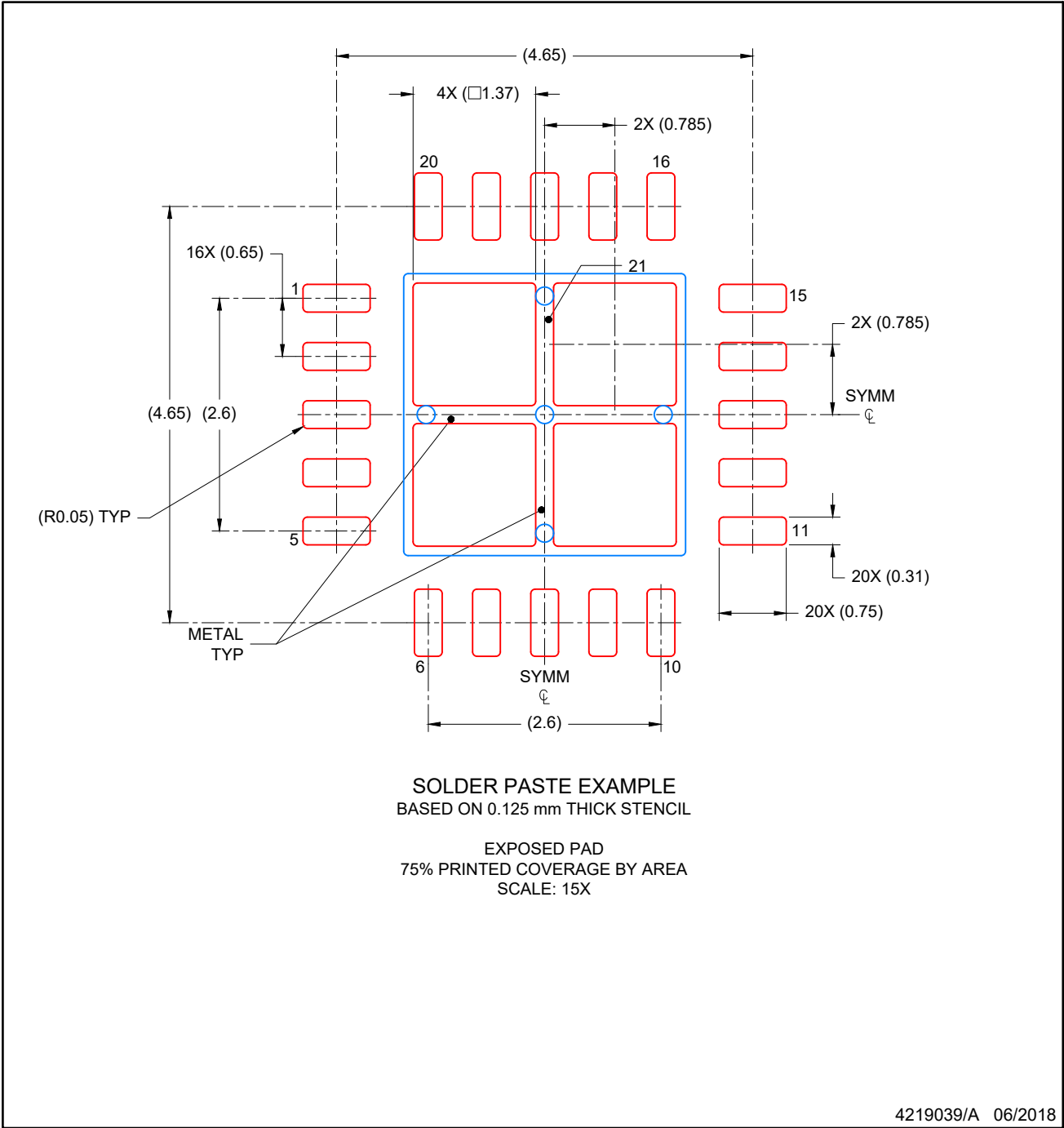

NOTES: (continued)

- 6. Laser cutting apertures with trapezoidal walls and rounded corners may offer better paste release. IPC-7525 may have alternate design recommendations.

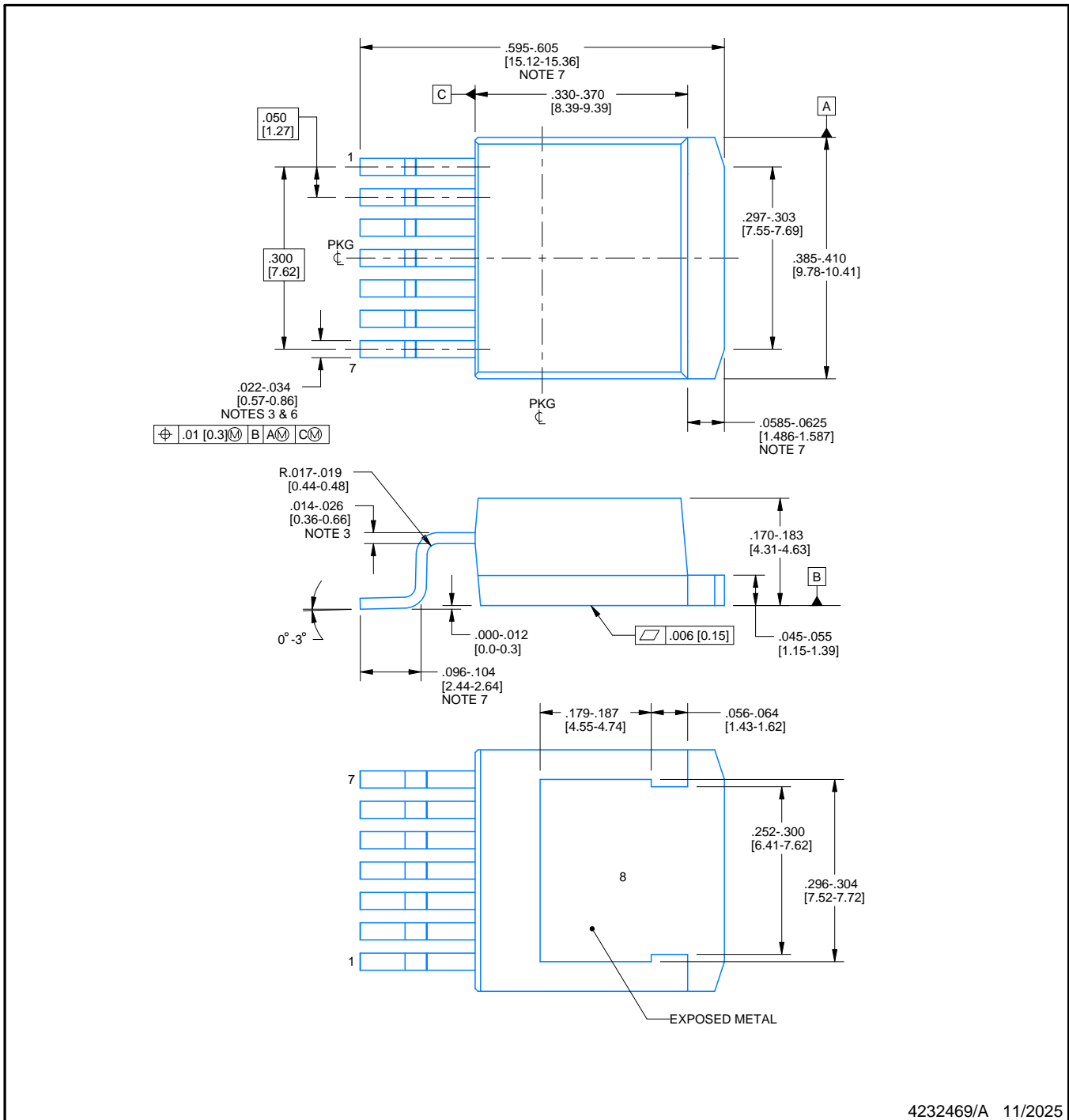
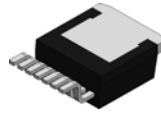

4232469/A 11/2025

NOTES:

1. All linear dimensions are in inches [millimeters]. Any dimensions in parenthesis are for reference only. Dimensioning and tolerancing per ASME Y14.5M.
2. This drawing is subject to change without notice.
3. Lead width and height dimensions apply to the plated lead.
4. Leads are not allowed above the Datum B.
5. Stand-off height is measured from lead tip with reference to Datum B.
6. Lead width dimension does not include dambar protrusion. Allowable dambar protrusion shall not cause the lead width to exceed the maximum dimension by more than 0.003".
7. Falls within JEDEC MO-169 with the exception of the dimensions indicated.

# EXAMPLE BOARD LAYOUT

KTW0007A

TO-263 - 5 mm max height

TRANSISTOR OUTLINE

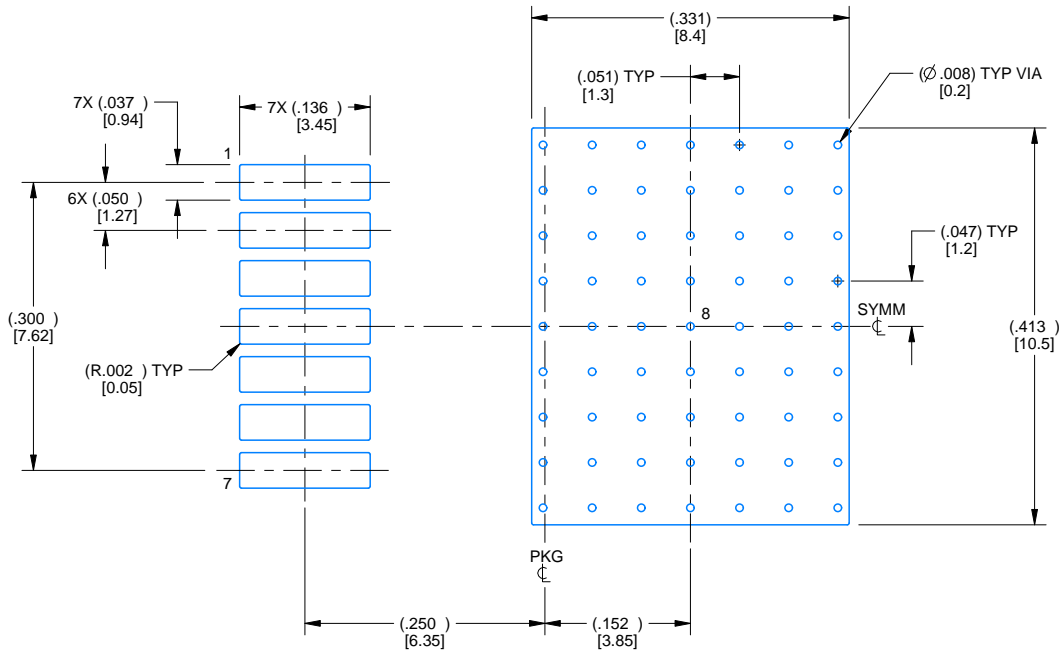

LAND PATTERN EXAMPLE  
EXPOSED METAL SHOWN  
SCALE: 5X

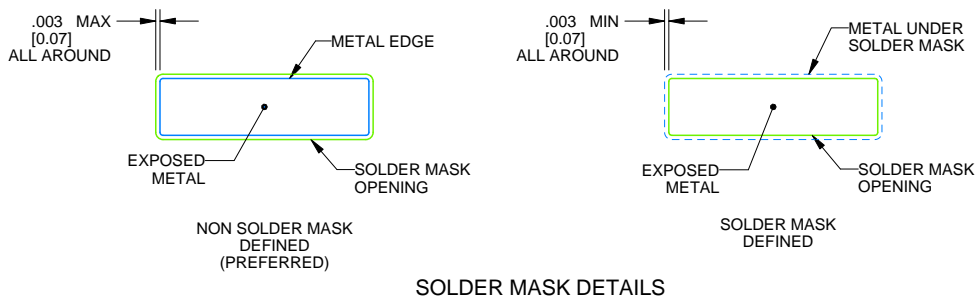

SOLDER MASK DETAILS

4232469/A 11/2025

NOTES: (continued)

8. This package is designed to be soldered to a thermal pad on the board. For more information, see Texas Instruments literature numbers SLMA002([www.ti.com/lit/slm002](http://www.ti.com/lit/slm002)) and SLMA004 ([www.ti.com/lit/slma004](http://www.ti.com/lit/slma004)).
9. Vias are optional depending on application, refer to device data sheet. It is recommended that vias under paste be filled, plugged or tented.

# EXAMPLE STENCIL DESIGN

KTW0007A

TO-263 - 5 mm max height

TRANSISTOR OUTLINE

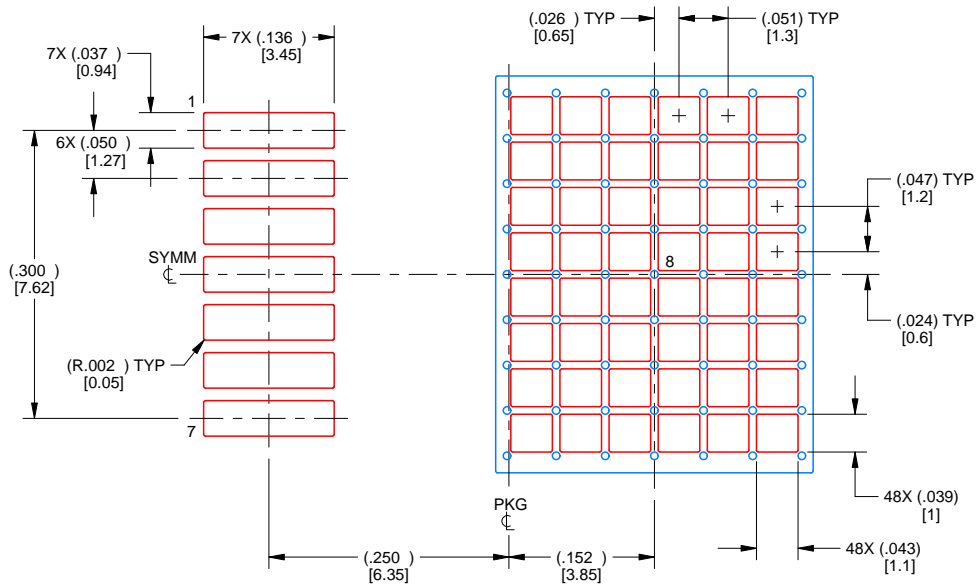

SOLDER PASTE EXAMPLE  
 BASED ON 0.125 mm THICK STENCIL  
 SCALE: 5X

PRINTED SOLDER COVERAGE BY AREA UNDER PACKAGE  
 PAD 8: 60%

4232469/A 11/2025

NOTES: (continued)

10. Laser cutting apertures with trapezoidal walls and rounded corners may offer better paste release. IPC-7525 may have alternate design recommendations.
11. Board assembly site may have different recommendations for stencil design.

## GENERIC PACKAGE VIEW

**RGR 20**

**VQFN - 1 mm max height**

3.5 x 3.5, 0.5 mm pitch

PLASTIC QUAD FLATPACK - NO LEAD

This image is a representation of the package family, actual package may vary.  
Refer to the product data sheet for package details.

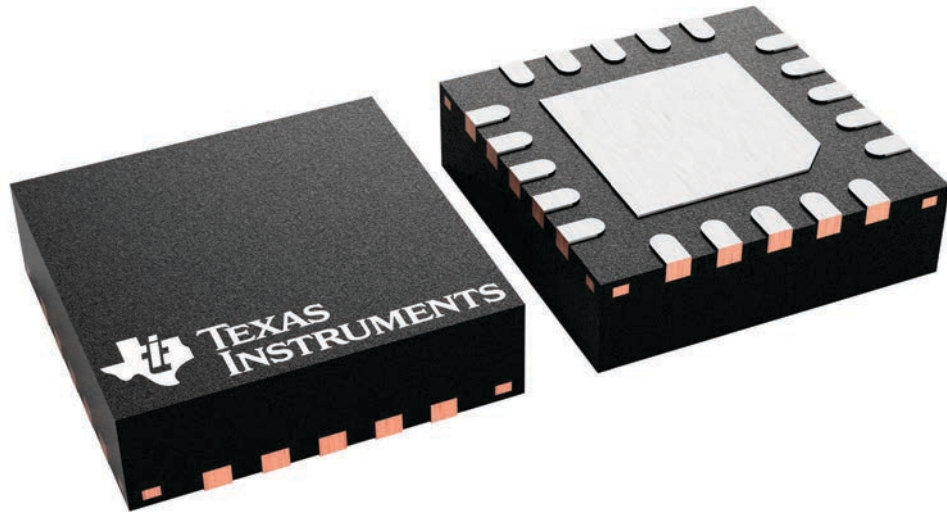

4228482/A



# EXAMPLE BOARD LAYOUT

RGR0020A

VQFN - 1 mm max height

PLASTIC QUAD FLATPACK - NO LEAD

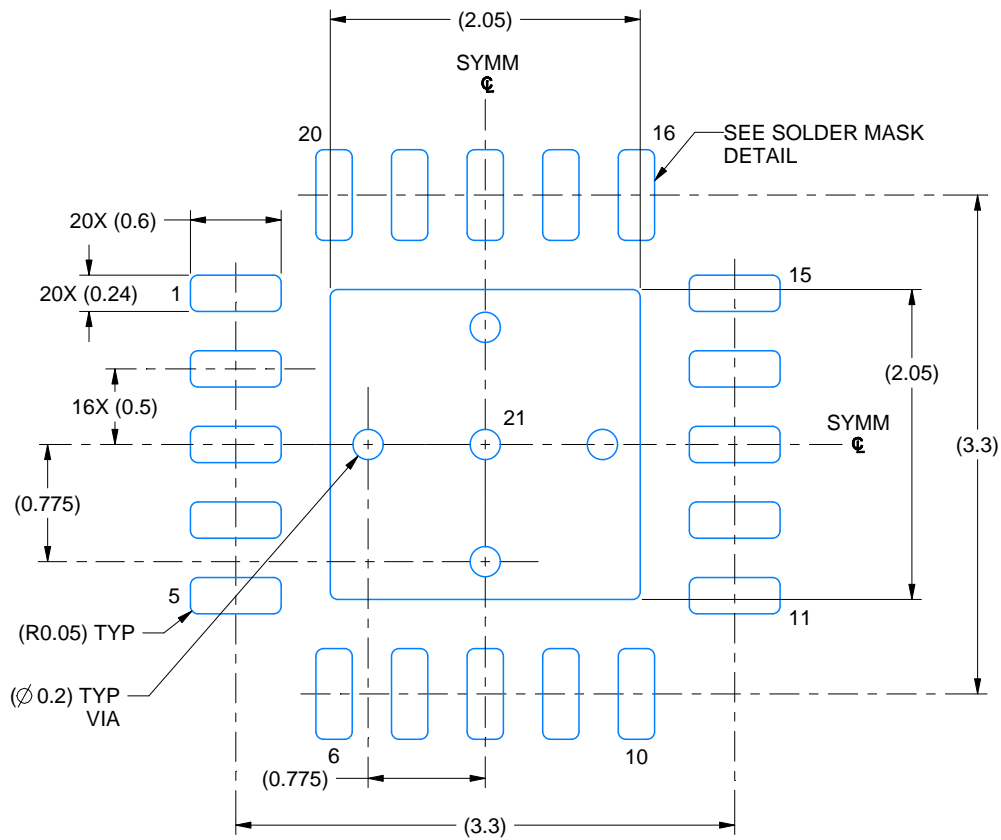

LAND PATTERN EXAMPLE  
EXPOSED METAL SHOWN  
SCALE: 20X

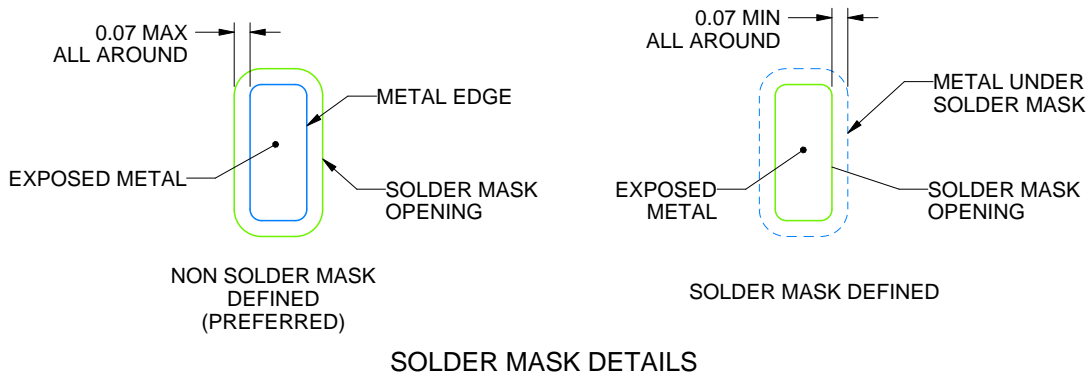

SOLDER MASK DETAILS

4219031/B 04/2022

NOTES: (continued)

4. This package is designed to be soldered to a thermal pad on the board. For more information, see Texas Instruments literature number SLUA271 ([www.ti.com/lit/sluea271](http://www.ti.com/lit/sluea271)).
5. Vias are optional depending on application, refer to device data sheet. If any vias are implemented, refer to their locations shown on this view. It is recommended that vias under paste be filled, plugged or tented.

# EXAMPLE STENCIL DESIGN

RGR0020A

VQFN - 1 mm max height

PLASTIC QUAD FLATPACK - NO LEAD

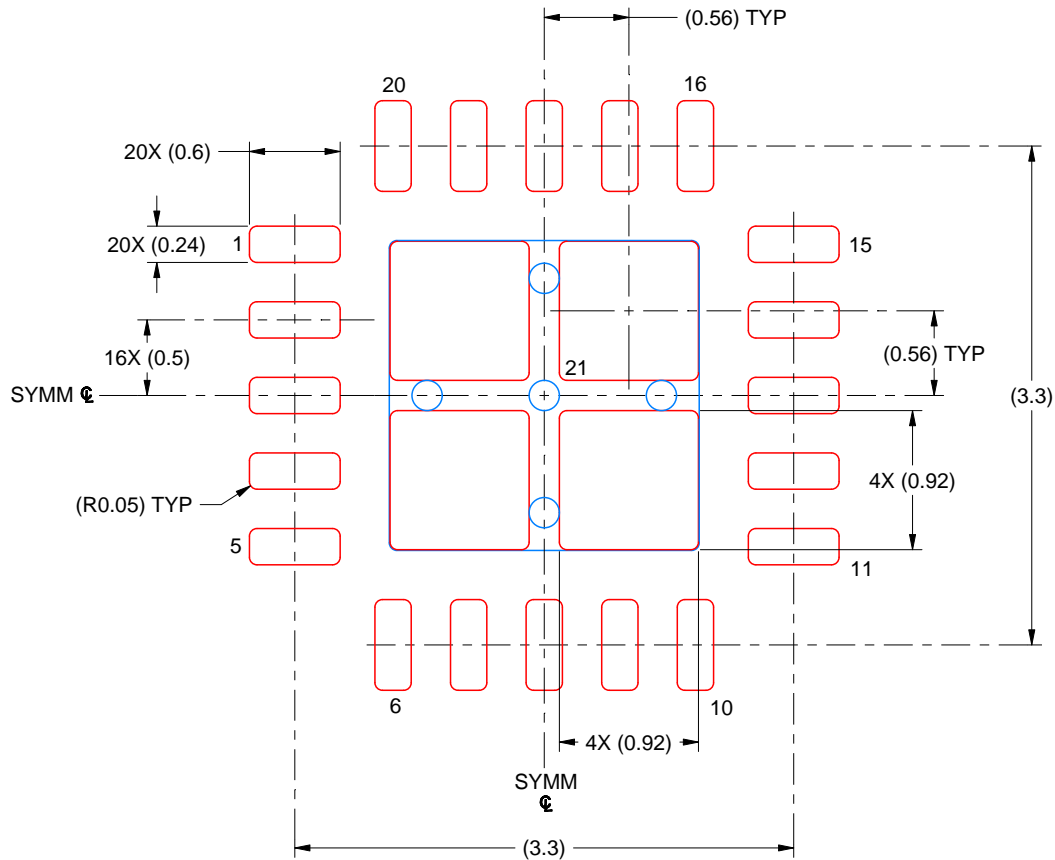

SOLDER PASTE EXAMPLE  
BASED ON 0.125 MM THICK STENCIL  
SCALE: 20X

EXPOSED PAD 21  
81% PRINTED SOLDER COVERAGE BY AREA UNDER PACKAGE

4219031/B 04/2022

NOTES: (continued)

6. Laser cutting apertures with trapezoidal walls and rounded corners may offer better paste release. IPC-7525 may have alternate design recommendations.

## IMPORTANT NOTICE AND DISCLAIMER

TI PROVIDES TECHNICAL AND RELIABILITY DATA (INCLUDING DATASHEETS), DESIGN RESOURCES (INCLUDING REFERENCE DESIGNS), APPLICATION OR OTHER DESIGN ADVICE, WEB TOOLS, SAFETY INFORMATION, AND OTHER RESOURCES "AS IS" AND WITH ALL FAULTS, AND DISCLAIMS ALL WARRANTIES, EXPRESS AND IMPLIED, INCLUDING WITHOUT LIMITATION ANY IMPLIED WARRANTIES OF MERCHANTABILITY, FITNESS FOR A PARTICULAR PURPOSE OR NON-INFRINGEMENT OF THIRD PARTY INTELLECTUAL PROPERTY RIGHTS.

These resources are intended for skilled developers designing with TI products. You are solely responsible for (1) selecting the appropriate TI products for your application, (2) designing, validating and testing your application, and (3) ensuring your application meets applicable standards, and any other safety, security, regulatory or other requirements.

These resources are subject to change without notice. TI grants you permission to use these resources only for development of an application that uses the TI products described in the resource. Other reproduction and display of these resources is prohibited. No license is granted to any other TI intellectual property right or to any third party intellectual property right. TI disclaims responsibility for, and you fully indemnify TI and its representatives against any claims, damages, costs, losses, and liabilities arising out of your use of these resources.

TI's products are provided subject to [TI's Terms of Sale](#), [TI's General Quality Guidelines](#), or other applicable terms available either on [ti.com](http://ti.com) or provided in conjunction with such TI products. TI's provision of these resources does not expand or otherwise alter TI's applicable warranties or warranty disclaimers for TI products. Unless TI explicitly designates a product as custom or customer-specified, TI products are standard, catalog, general purpose devices.

TI objects to and rejects any additional or different terms you may propose.

Copyright © 2026, Texas Instruments Incorporated

Last updated 10/2025