

TPS61169 38V High Current-Boost WLED Driver With PWM Control

1 Features

- 2.7V to 5.5V input voltage
- Integrated 40V, 1.8A MOSFET
- Drives LED string up to 38V
- 1.2A minimum switch current Limit
- 1.2MHz switching frequency
- 204mV reference voltage
- Internal compensation
- PWM brightness control
- Open LED protection
- Undervoltage protection
- Built-in soft-start
- Thermal shutdown
- Up to 90% efficiency

2 Applications

- Smartphone backlighting
- Tablet backlighting
- PDAs, handheld computers, GPS receivers
- Portable media players, portable TVs
- White LED backlighting for small and media form-factor displays
- Handheld data terminals (EPOS)
- Handheld medical equipment
- Thermostat display
- Blood glucose mMeters
- Flashlights
- Refrigerators and ovens

3 Description

With a 40V rated integrated switch FET, the TPS61169 is a boost converter that drives LEDs in series. The boost converter has a 40V, 1.8A internal MOSFET with minimum 1.2A current limit; thus it can drive single or parallel LED strings for small- to large-size panel backlighting. The default white LED current is set with the external sensor resistor, R_{SET} , and the feedback voltage is regulated to 204mV, as shown in the [Simplified Schematic](#). During the operation, the LED current can be controlled by using a pulse width modulation (PWM) signal applied to the CTRL pin, through which the duty cycle determines the feedback reference voltage. The TPS61169 does not burst the LED current; therefore, it does not generate audible noises on the output capacitor. For maximum protection, the device features integrated open LED protection that disables the TPS61169 to prevent the output voltage from exceeding the absolute maximum voltage ratings of the device during open LED conditions.

The TPS61169 is available in a space-saving 5-pin SC70 package.

Device Information⁽¹⁾

PART NUMBER	PACKAGE	BODY SIZE (NOM)
TPS61169	SOT (5)	2.00mm × 1.25mm

(1) For all available packages, see the orderable addendum at the end of the data sheet.

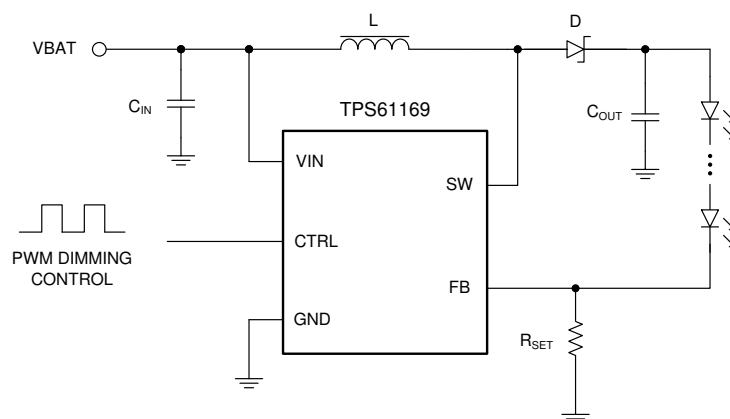

Simplified Schematic



Table of Contents

1 Features	1	7 Application and Implementation	11
2 Applications	1	7.1 Application Information.....	11
3 Description	1	7.2 Typical Application.....	11
4 Pin Configuration and Functions	3	7.3 Application Curves.....	14
5 Specifications	4	7.4 Power Supply Recommendations.....	16
5.1 Absolute Maximum Ratings.....	4	7.5 Layout.....	16
5.2 ESD Ratings.....	4	8 Device and Documentation Support	17
5.3 Recommended Operating Conditions.....	4	8.1 Device Support.....	17
5.4 Thermal Information.....	4	8.2 Receiving Notification of Documentation Updates....	17
5.5 Electrical Characteristics.....	5	8.3 Support Resources.....	17
5.6 Typical Characteristics.....	6	8.4 Trademarks.....	17
6 Detailed Description	7	8.5 Electrostatic Discharge Caution.....	17
6.1 Overview.....	7	8.6 Glossary.....	17
6.2 Functional Block Diagram.....	8	9 Revision History	17
6.3 Feature Description.....	8	10 Mechanical, Packaging, and Orderable Information	17
6.4 Device Functional Modes.....	10		

4 Pin Configuration and Functions

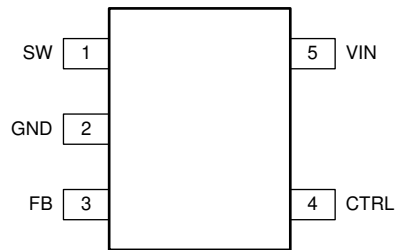

Figure 4-1. DCK Package 5-Pin SC70 (Top View)

Table 4-1. Pin Functions

PIN		I/O	DESCRIPTION
NUMBER	NAME		
1	SW	I	Drain connection of the internal power FET.
2	GND	O	Ground
3	FB	I	Feedback pin for current. Connect the sense resistor from FB to GND.
4	CTRL	I	PWM dimming signal input
5	VIN	I	Supply input pin

5 Specifications

5.1 Absolute Maximum Ratings

over operating free-air temperature range (unless otherwise noted)⁽¹⁾

		MIN	MAX	UNIT
Voltage ⁽²⁾	VIN, CTRL, PWM, FB	-0.3	7	V
	SW	-0.3	40	
P _D	Continuous power dissipation	See Thermal Information Table		
T _J	Operating junction temperature	-40	150	°C
T _{stg}	Storage temperature	-65	150	°C

- (1) Stresses beyond those listed under *Absolute Maximum Ratings* may cause permanent damage to the device. These are stress ratings only, which do not imply functional operation of the device at these or any other conditions beyond those indicated under *Recommended Operating Conditions*. Exposure to absolute-maximum-rated conditions for extended periods may affect device reliability.
- (2) All voltage values are with respect to network ground terminal.

5.2 ESD Ratings

		VALUE	UNIT
V _(ESD)	Electrostatic discharge	Human-body model (HBM), per ANSI/ESDA/JEDEC JS-001 ⁽¹⁾	±2000
		Charged-device model (CDM), per JEDEC specification JESD22-C101 ⁽²⁾	±500

- (1) JEDEC document JEP155 states that 500-V HBM allows safe manufacturing with a standard ESD control process.
- (2) JEDEC document JEP157 states that 250-V CDM allows safe manufacturing with a standard ESD control process.

5.3 Recommended Operating Conditions

		MIN	NOM	MAX	UNIT
V _{IN}	Input voltage	2.7		5.5	V
V _{OUT}	Output voltage	V _{IN}		38	V
L	Inductor	4.7		10	μH
C _I	Input capacitor	1			μF
C _O	Output capacitor	1		10	μF
F _{PWM}	PWM dimming signal frequency	5		100	kHz
D _{PWM}	PWM dimming signal duty cycle	1%		100%	
T _J	Operating junction temperature	-40		125	°C

5.4 Thermal Information

THERMAL METRIC ⁽¹⁾		TPS61169	UNIT
		DCK (SC70)	
		5 PINS	
R _{θJA}	Junction-to-ambient thermal resistance ⁽²⁾	263.8	°C/W
R _{θJC(top)}	Junction-to-case (top) thermal resistance ⁽³⁾	76.1	°C/W
R _{θJB}	Junction-to-board thermal resistance ⁽⁴⁾	51.4	°C/W
ψ _{JT}	Junction-to-top characterization parameter ⁽⁵⁾	1.1	°C/W
ψ _{JB}	Junction-to-board characterization parameter ⁽⁶⁾	50.7	°C/W

- (1) For more information about traditional and new thermal metrics, see the *Semiconductor and IC Package Thermal Metrics* application report, [SPRA953](#).
- (2) The junction-to-ambient thermal resistance under natural convection is obtained in a simulation on a JEDEC-standard, high-K board, as specified in JESD51-7, in an environment described in JESD51-2a.
- (3) The junction-to-case (top) thermal resistance is obtained by simulating a cold plate test on the package top. No specific JEDEC-standard test exists, but a close description can be found in the ANSI SEMI standard G30-88.

- (4) The junction-to-board thermal resistance is obtained by simulating in an environment with a ring cold plate fixture to control the PCB temperature, as described in JESD51-8.
- (5) The junction-to-top characterization parameter, ψ_{JT} , estimates the junction temperature of a device in a real system and is extracted from the simulation data for obtaining $R_{\theta JA}$, using a procedure described in JESD51-2a (sections 6 and 7).
- (6) The junction-to-board characterization parameter, ψ_{JB} , estimates the junction temperature of a device in a real system and is extracted from the simulation data for obtaining $R_{\theta JA}$, using a procedure described in JESD51-2a (sections 6 and 7).

5.5 Electrical Characteristics

Over operating free-air temperature range, $V_{IN} = 3.6V$, $CTRL = V_{IN}$ (unless otherwise specified).

PARAMETER		TEST CONDITIONS	MIN	TYP	MAX	UNIT
POWER SUPPLY						
V_{IN}	Input voltage range		2.7		5.5	V
V_{VIN_UVLO}	Undervoltage lockout threshold	V_{IN} falling V_{IN} rising		2	2.3 2.6	V
V_{VIN_HYS}	V_{IN} UVLO hysteresis			200		mV
I_{Q_VIN}	Operating quiescent current into V_{IN}	Device enable, switching 1.2MHz and no load,		0.3	0.45	mA
I_{SD}	Shutdown current	CTRL = GND		1	2	μ A
CONTROL LOGIC AND TIMING						
V_H	CTRL Logic high voltage		1.2			V
V_L	CTRL Logic Low voltage				0.4	V
R_{PD}	CTRL pin internal pull-down resistor			300		K Ω
t_{SD}	CTRL logic low time to shutdown	CTRL high to low			2.5	ms
VOLTAGE AND CURRENT REGULATION						
V_{REF}	Voltage feedback regulation voltage	Duty = 100%, $T_A \geq 25^\circ C$	188	204	220	mV
I_{FB}	FB pin bias current	$V_{FB} = 204mV$			2.5	μ A
t_{REF}	V_{REF} filter time constant			1		ms
POWER SWITCH						
$R_{DS(ON)}$	N-channel MOSFET on-resistance			0.35	0.7	Ω
I_{LN_NFET}	N-channel leakage current	$V_{SW} = 35V$			1	μ A
SWITCHING FREQUENCY						
f_{SW}	Switching frequency	$V_{IN} = 3V$	0.75	1.2	1.5	MHz
PROTECTION AND SOFT START						
I_{LIM}	Switching MOSFET current limit	$D = D_{MAX}$, $T_A \leq 85^\circ C$	1.2	1.8	2.4	A
I_{LIM_Start}	Switching MOSFET start-up current limit	$T_A \leq 85^\circ C$		0.72		A
t_{Half_LIM}	Time step for half current limit			6.5		ms
V_{OVP_SW}	Output voltage overvoltage threshold		36	37.5	39	V
THERMAL SHUTDOWN						
$T_{shutdown}$	Thermal shutdown threshold			160		$^\circ C$
T_{hys}	Thermal shutdown hysteresis			15		$^\circ C$

5.6 Typical Characteristics

At $T_A = 25^\circ\text{C}$, unless otherwise noted.

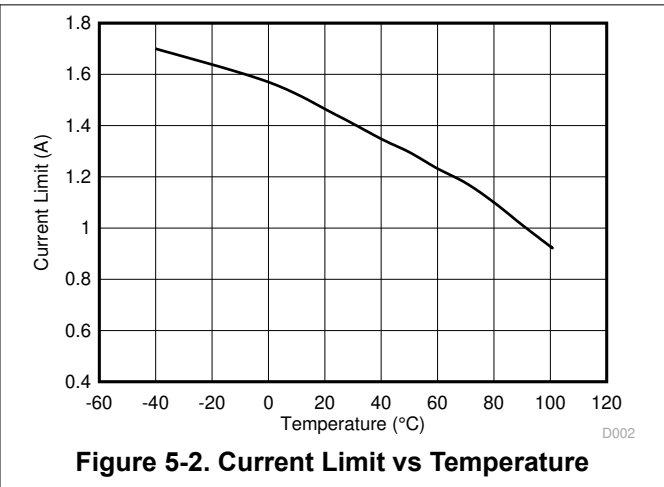
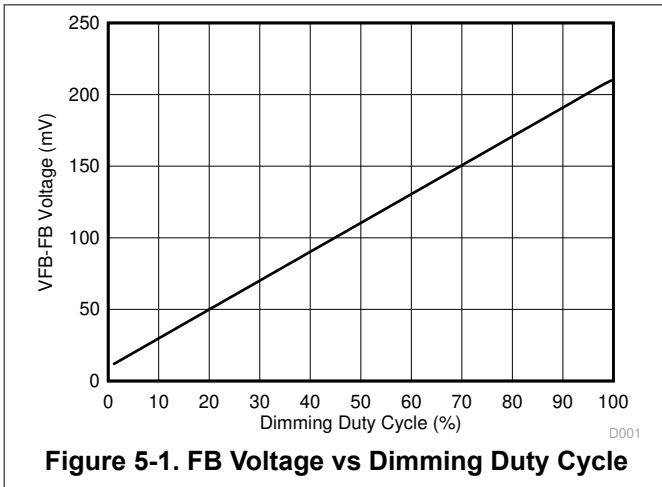

6 Detailed Description

6.1 Overview

The TPS61169 is a high-efficiency, high-output voltage boost converter in small package size. The device integrates 40V/1.8A switch FET and is designed for output voltage up to 39V with a switch peak current limit of 1.2A minimum. Its large driving capability can drive single or parallel LED strings for small to large size panel backlighting.

The TPS61169 operates in a current mode scheme with quasi-constant frequency. It is internally compensated for maximum flexibility and stability. The switching frequency is 1.2MHz, and the minimum input voltage is 2.7V. During the on-time, the current rises into the inductor. When the current reaches a threshold value set by the internal GM amplifier, the power switch MOSFET is turned off. The polarity of the inductor changes and forward biases the schottky diode which lets the current flow towards the output of the boost converter. The off-time is fixed for a certain V_{IN} and V_{OUT} , and therefore maintains the same frequency when varying these parameters.

However, for different output loads, the frequency slightly changes due to the voltage drop across the $R_{DS(ON)}$ of the power switch MOSFET, this has an effect on the voltage across the inductor and thus on t_{ON} (t_{OFF} remains fixed). The fixed off-time maintains a quasi-fixed frequency that provides better stability for the system over a wider range of input and output voltages than conventional boost converters. The TPS61169 topology has also the benefits of providing very good load and line regulations, and excellent line and load transient responses.

The feedback loop regulates the FB pin to a low reference voltage (204mV typical), reducing the power dissipation in the current sense resistor.

6.2 Functional Block Diagram

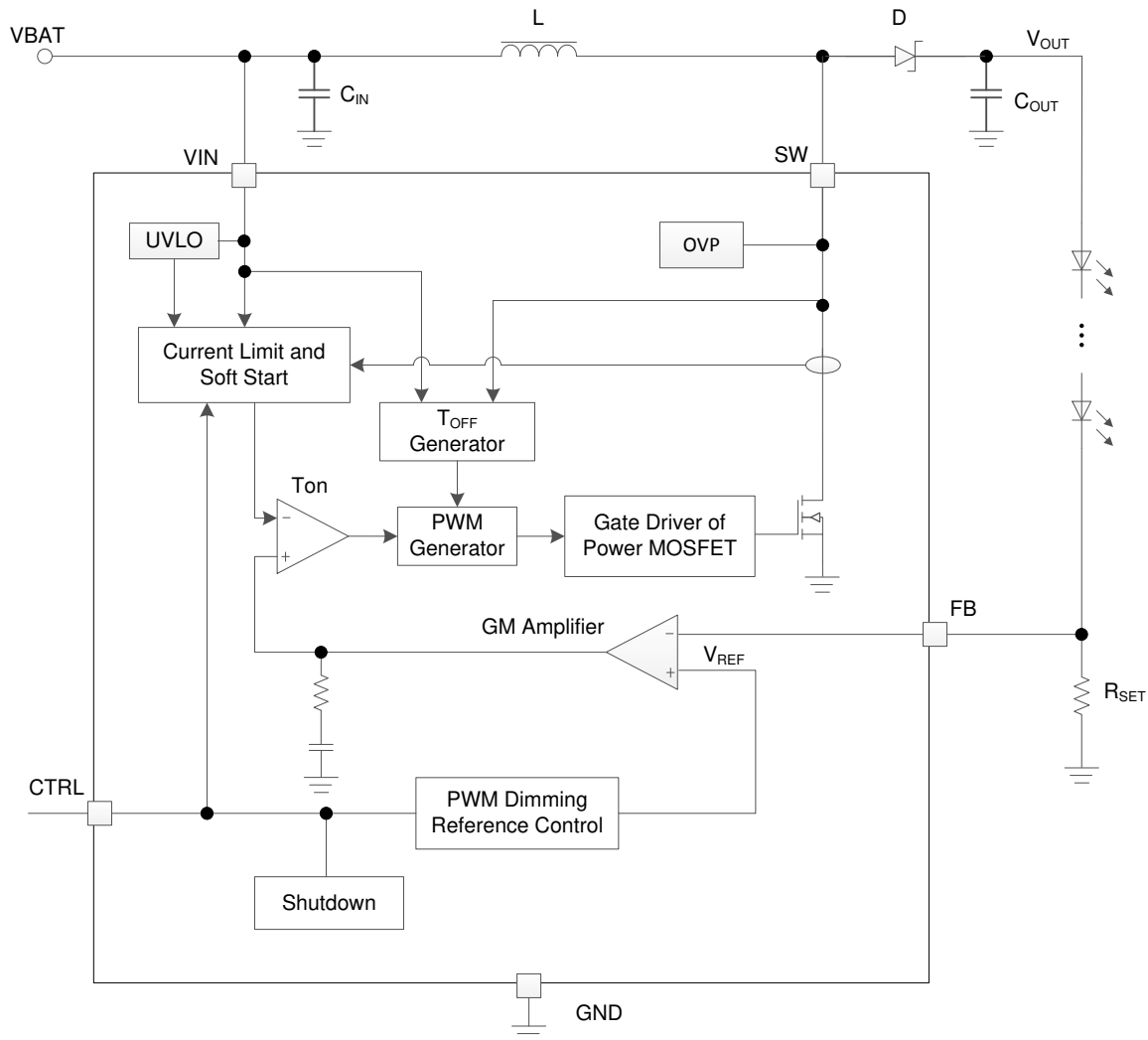

6.3 Feature Description

6.3.1 Soft Start-Up

Soft-start circuitry is integrated into the device to avoid high inrush current spike during start-up. After the device is enabled, the GM amplifier output voltage ramps up very slowly, which ensures that the output voltage rises slowly to reduce the input current. During this period, the switch current limit is set to 0.72A. After around 6.5ms, the switch current limit changes back to I_{LIM} , and the FB pin voltage ramps up to the reference voltage slowly. These features ensure the smooth start-up and minimize the inrush current. See [Figure 7-9](#) for a typical example.

6.3.2 Open LED Protection

Open LED protection circuitry prevents the device from damage as the result of white LED disconnection. The TPS61169 monitors the voltage at the SW pin and FB pin during each switching cycle. The circuitry turns off the switch FET and shuts down the device when both of the following conditions persist for 3 switching cycles: (1) the SW voltage exceeds the VOVP threshold, and (2) the FB voltage is less than 30mV. As the result, the output voltage falls to the level of the input supply. The device remains in shutdown mode until it is enabled by toggling the CTRL pin.

6.3.3 Shutdown

The TPS61169 enters shutdown mode when the CTRL voltage is logic low for more than 2.5ms. During shutdown, the input supply current for the device is less than 2µA (max). Although the internal switch FET does not switch in shutdown, there is still a DC current path between the input and the LEDs through the inductor and Schottky diode. The minimum forward voltage of the LED array must exceed the maximum input voltage to ensure that the LEDs remain off in shutdown.

6.3.4 Current Program

The FB voltage is regulated by a low 204mV reference voltage. The LED current is programmed externally using a current-sense resistor in series with the LED string(s). The value of the R_{SET} is calculated using:

$$I_{LED} = \frac{V_{FB}}{R_{SET}} \quad (1)$$

where

- I_{LED} = total output current of LED string(s)
- V_{FB} = regulated voltage of FB pin
- R_{SET} = current sense resistor

The output current tolerance depends on the FB accuracy and the current sensor resistor accuracy.

6.3.5 LED Brightness Dimming

The TPS61169 receives PWM dimming signal at CTRL pin to control the total output current. When the CTRL pin is constantly high, the FB voltage is regulated to 204mV typically. When the duty cycle of the input PWM signal is low, the regulation voltage at FB pin is reduced, and the total output current is reduced; therefore, it achieves LED brightness dimming. The relationship between the duty cycle and FB regulation voltage is given by:

$$V_{FB} = \text{Duty} \times 204 \text{ mV} \quad (2)$$

where

- Duty = Duty cycle of the PWM signal
- 204mV = internal reference voltage

Thus, the user can easily control the WLED brightness by controlling the duty cycle of the PWM signal.

As shown in [Figure 6-1](#), the device chops up the internal 204mV reference voltage at the duty cycle of the PWM signal. The pulse signal is then filtered by an internal low-pass filter. The output of the filter is connected to the GM amplifier as the reference voltage for the FB pin regulation. Therefore, although a PWM signal is used for brightness dimming, only the WLED DC current is modulated, which is often referred as analog dimming. This eliminates the audible noise which often occurs when the LED current is pulsed in replica of the frequency and duty cycle of PWM control. Unlike other methods which filter the PWM signal for analog dimming, TPS61169 regulation voltage is independent of the PWM logic voltage level which often has large variations.

For optimum performance, use the PWM dimming frequency in the range of 5kHz to 100kHz. If the PWM frequency is lower than 5kHz, it is out of the low pass filter's filter range, the FB regulation voltage ripple becomes large, causing large output ripple and may generate audible noise.

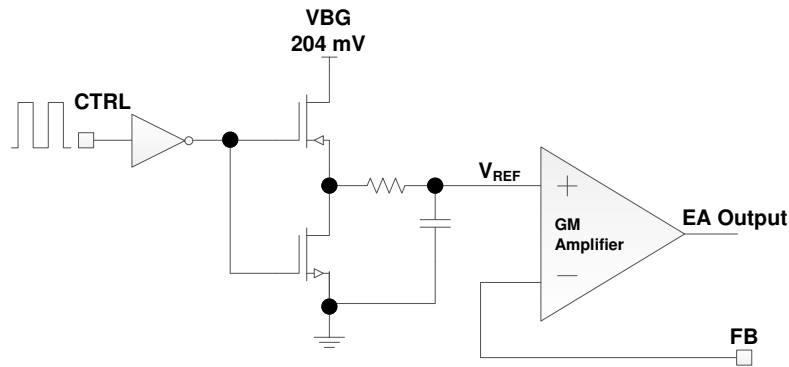

Figure 6-1. Programmable FB Voltage Using PWM Signal

6.3.6 Undervoltage Lockout

An undervoltage lockout prevents operation of the device at input voltages below typical 2V. When the input voltage is below the undervoltage threshold, the device is shut down, and the internal switch FET is turned off. If the input voltage rises by undervoltage lockout hysteresis, the device restarts.

6.3.7 Thermal Foldback and Thermal Shutdown

When TPS61169 drives heavy load for large size panel applications, the power dissipation increases a lot and the device junction temperature may reach a very high value, affecting the device function and reliability. In order to lower the thermal stress, the TPS61169 features a thermal foldback function. When the junction temperature is higher than 100°C, the switch current limit I_{LIM} is reduced automatically as Figure 5-2 shows. This thermal foldback mechanism controls the power dissipation and keeps the junction temperature from rising to a very high value. If the typical junction temperature of 160°C is exceeded, an internal thermal shutdown turns off the device. The device is released from shutdown automatically when the junction temperature decreases by 15°C.

6.4 Device Functional Modes

6.4.1 Operation With CTRL

The enable rising edge threshold voltage is 1.2V. When the CTRL pin is held below that voltage the device is disabled and switching is inhibited. The the device's quiescent current is reduced in this state. When input voltage is above the UVLO threshold, and the CTRL pin voltage is increased above the rising edge threshold, the device becomes active. Switching enables, and the soft-start sequence initiates.

7 Application and Implementation

Note

Information in the following applications sections is not part of the TI component specification, and TI does not warrant its accuracy or completeness. TI's customers are responsible for determining suitability of components for their purposes, as well as validating and testing their design implementation to confirm system functionality.

7.1 Application Information

The TPS61169 device is a step-up DC-DC converter which can drive single or parallel LED strings for small-to large-size panel backlighting. This section includes a design procedure ([Detailed Design Procedure](#)) to select component values for the TPS61169 typical application ([Figure 7-1](#)).

7.2 Typical Application

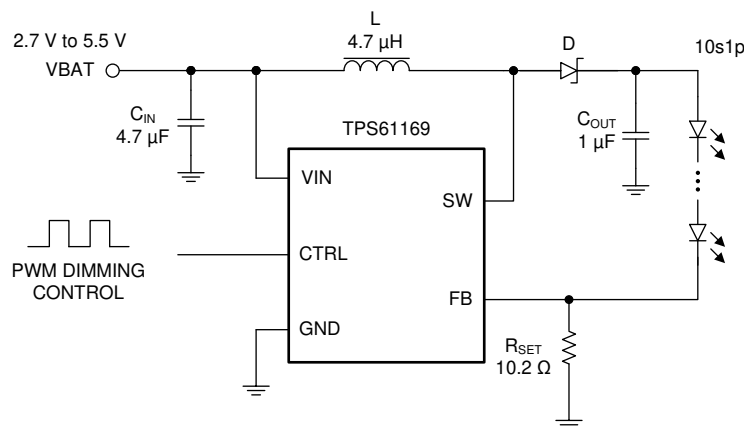

Figure 7-1. TPS61169 2.7V to 5.5V Input, 10 LEDs in Series Output Converter

7.2.1 Design Requirements

For this design example, use the parameters listed in [Table 7-1](#) as the input parameters.

Table 7-1. Design Parameters

DESIGN PARAMETER	EXAMPLE VALUE
Input voltage range	2.7V to 5.5V
Output, LED number in a string	10
Output, LED string number	1
Output, LED current per string	20mA

7.2.2 Detailed Design Procedure

7.2.2.1 Inductor Selection

The selection of the inductor affects power efficiency, steady state operation as well as transient behavior and loop stability. These factors make it the most important component in power regulator design. There are three important inductor specifications, inductor value, DC resistance and saturation current. Considering inductor value alone is not enough. The inductor value determines the inductor ripple current. Choose an inductor that can handle the necessary peak current without saturating. Follow [Equation 3](#) to [Equation 4](#) to calculate the peak current of the inductor. To calculate the current in the worst case, use the minimum input voltage, maximum output voltage and maximum load current of application. In a boost regulator, the input DC current can be calculated as [Equation 3](#).

$$I_{L(DC)} = \frac{V_{OUT} \times I_{OUT}}{V_{IN} \times \eta} \quad (3)$$

where

- V_{OUT} = boost output voltage
- I_{OUT} = boost output current
- V_{IN} = boost input voltage
- η = power conversion efficiency

The inductor current peak to peak ripple can be calculated as [Equation 4](#).

$$\Delta I_{L(P-P)} = \frac{1}{L \times \left(\frac{1}{V_{OUT} - V_{IN}} + \frac{1}{V_{IN}} \right) \times F_S} \quad (4)$$

where

- $\Delta I_{L(P-P)}$ = inductor peak-to-peak ripple
- L = inductor value
- F_S = boost switching frequency
- V_{OUT} = boost output voltage
- V_{IN} = boost input voltage

Therefore, the peak current $I_{L(P)}$ seen by the inductor is calculated with [Equation 5](#).

$$I_{L(P)} = I_{L(DC)} + \frac{\Delta I_{L(P-P)}}{2} \quad (5)$$

Inductor values can have $\pm 20\%$ tolerance with no current bias. When the inductor current approaches saturation level, its inductance can decrease 20% to 35% from the 0A value depending on how the inductor vendor defines saturation current. Using an inductor with a smaller inductance value forces discontinuous PWM when the inductor current ramps down to zero before the end of each switching cycle. This reduces the boost converter's maximum output current, causes large input voltage ripple and reduces efficiency. Large inductance value provides much more output current and higher conversion efficiency. For these reasons, a 4.7 μ H to 10 μ H inductor value range is recommended, and 4.7 μ H inductor is recommended for higher than 5V input voltage by considering inductor peak current and loop stability. [Table 7-2](#) lists the recommended inductor for the TPS61169.

Table 7-2. Recommended Inductors for TPS61169

PART NUMBER	L (μ H)	DCR MAX (m Ω)	SATURATION CURRENT (A)	SIZE (L x W x H mm)	VENDOR
LPS4018-472ML	4.7	125	1.9	4 x 4 x 1.8	Coilcraft
LPS4018-103ML	10	200	1.3	4 x 4 x 1.8	Coilcraft
PCMB051H-4R7M	4.7	85	4	5.4 x 5.2 x 1.8	Cyntec
PCMB051H-100M	10	155	3	5.4 x 5.2 x 1.8	Cyntec

7.2.2.2 Schottky Diode Selection

The TPS61169 demands a low forward voltage, high-speed and low capacitance Schottky diode for optimum efficiency. Ensure that the diode average and peak current rating exceeds the average output current and peak inductor current. In addition, the diode reverse breakdown voltage must exceed the open LED protection voltage. ONSem NSR0240 is recommended for the TPS61169.

7.2.2.3 Output Capacitor Selection

The output capacitor is mainly selected to meet the requirement for the output ripple and loop stability. This ripple voltage is related to capacitor capacitance and its equivalent series resistance (ESR). Assuming a capacitor with zero ESR, the minimum capacitance needed for a given ripple can be calculated with [Equation 6](#):

$$C_{OUT} = \frac{(V_{OUT} - V_{IN}) \times I_{OUT}}{V_{OUT} \times F_S \times V_{ripple}} \quad (6)$$

where

- V_{ripple} = peak-to-peak output ripple

The additional part of the ripple caused by ESR is calculated using: $V_{ripple_ESR} = I_{OUT} \times R_{ESR}$

Due to its low ESR, V_{ripple_ESR} could be neglected for ceramic capacitors, a 1 μ F to 4.7 μ F capacitor is recommended for typical application.

7.2.2.4 LED Current Set Resistor

The LED current set resistor can be calculated by [Equation 1](#).

7.2.2.5 Thermal Considerations

The allowable IC junction temperature must be considered under normal operating conditions. This restriction limits the power dissipation of the TPS61169. The allowable power dissipation for the device can be determined by [Equation 7](#):

$$P_D = \frac{T_J - T_A}{R_{\theta JA}} \quad (7)$$

where

- T_J is allowable junction temperature given in recommended operating conditions
- T_A is the ambient temperature for the application
- $R_{\theta JA}$ is the thermal resistance junction-to-ambient given in Power Dissipation Table

The TPS61169 device also features a thermal foldback function to reduce the thermal stress automatically.

7.3 Application Curves

Typical application condition is as in Figure 7-1, $V_{IN} = 3.6V$, $R_{SET} = 10.2\Omega$, $L = 4.7\mu H$, $C_{OUT} = 1\mu F$, 10 LEDs in series (unless otherwise specified).

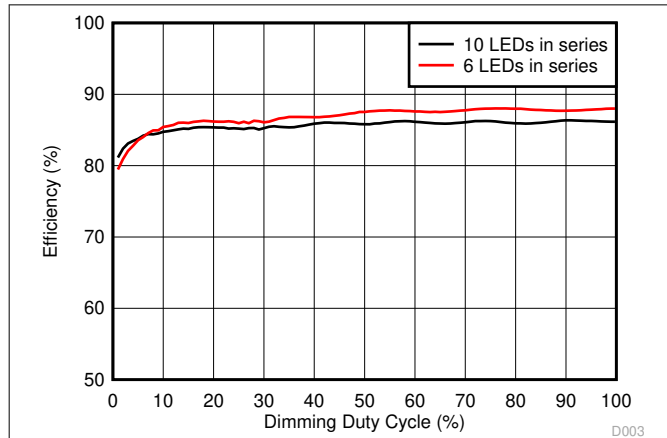

Figure 7-2. Efficiency vs Dimming Duty Cycle

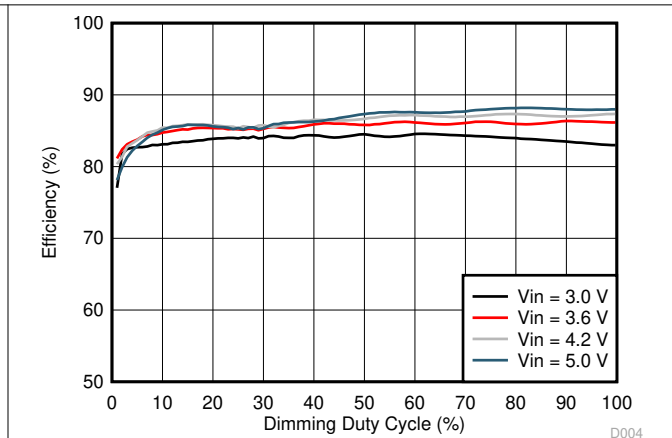

Figure 7-3. Efficiency vs Dimming Duty Cycle

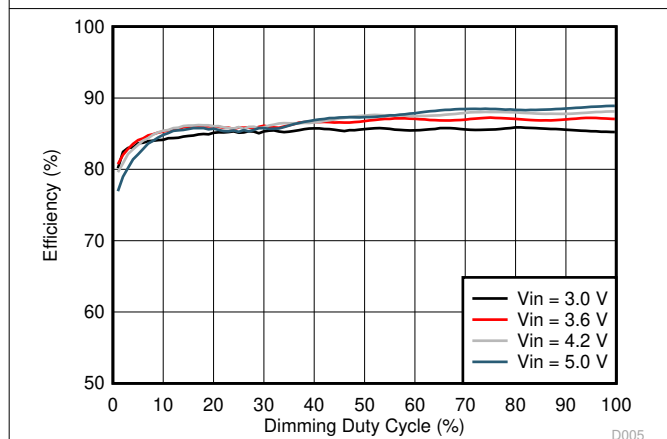

Figure 7-4. Efficiency vs Dimming Duty Cycle

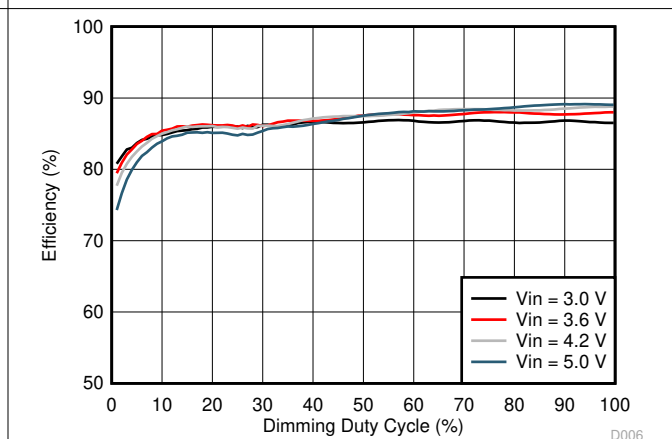

Figure 7-5. Efficiency vs Dimming Duty Cycle

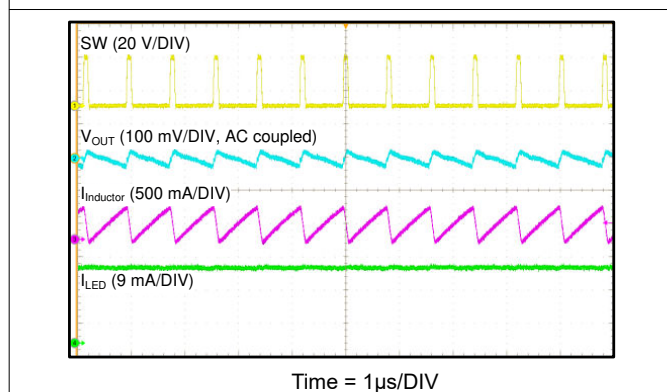

Figure 7-6. Switching-Dimming Duty = 100%

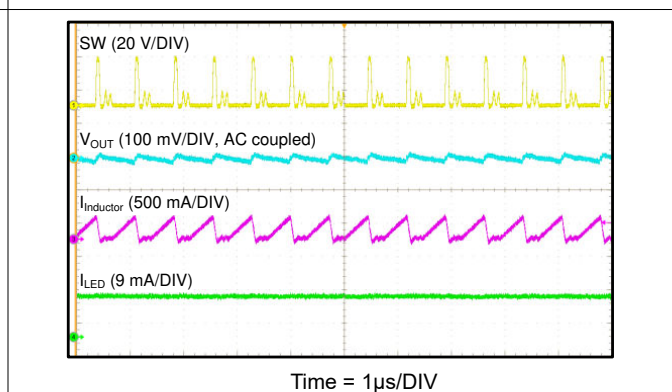
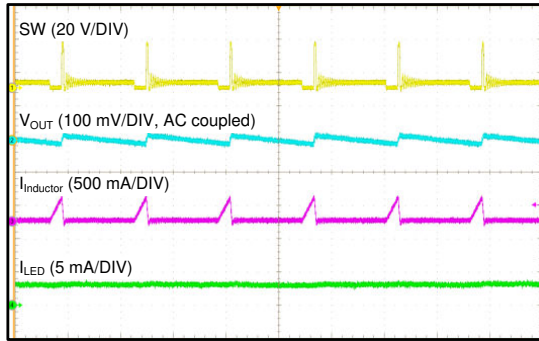
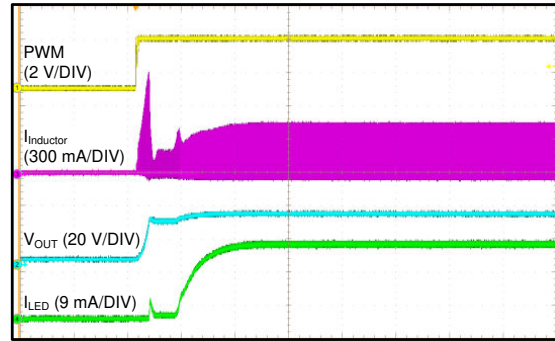

Figure 7-7. Switching-Dimming Duty = 50%



Time = 2μs/DIV

Figure 7-8. Switching-Dimming Duty = 10%



Time = 2ms/DIV

Figure 7-9. Start-Up Dimming Duty = 100%

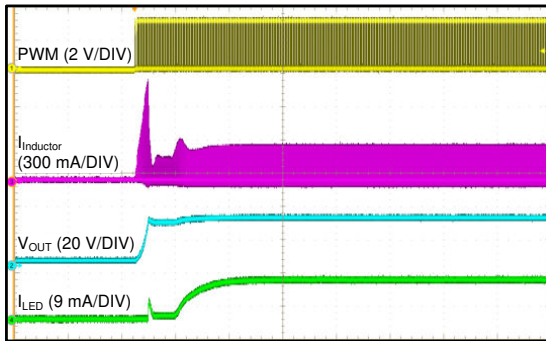

Time = 2ms/DIV

Figure 7-10. Start-Up Dimming Duty = 50%

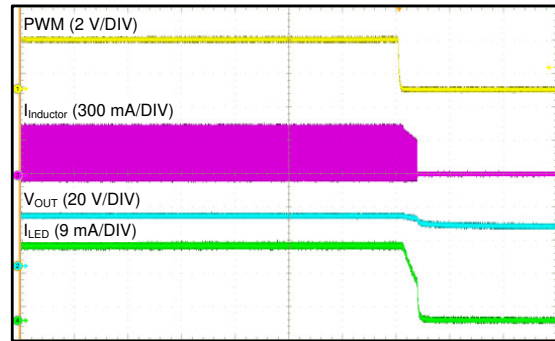

Time = 2ms/DIV

Figure 7-11. Shutdown Dimming Duty = 100%

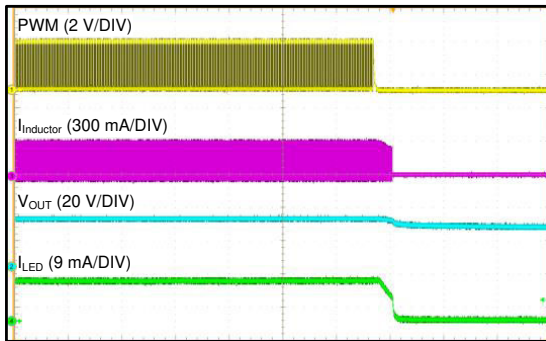

Time = 2ms/DIV
Duty = 50%

Figure 7-12. Shutdown Dimming

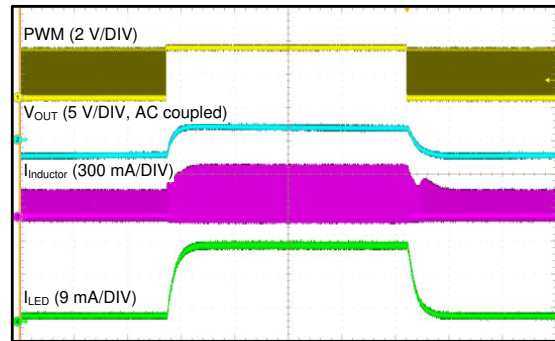

Time = 5ms/DIV
Duty = 1%-100%-1%

Figure 7-13. Dimming Transient-Dimming

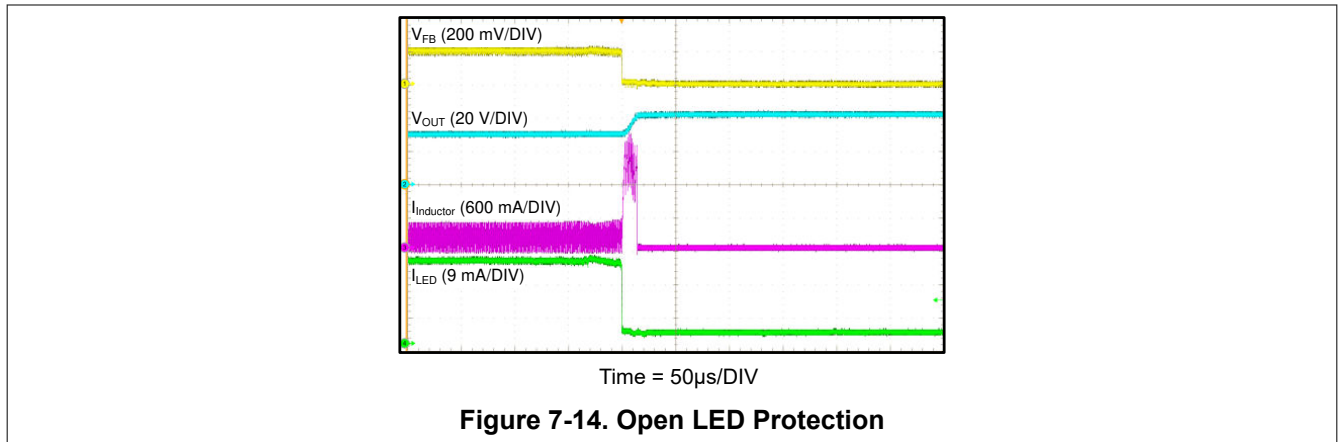

7.4 Power Supply Recommendations

The device is designed to operate from an input voltage supply range between 2.7V and 5.5V. This input supply must be well regulated. If the input supply is located more than a few inches from the TPS61169 device, additional bulk capacitance may be required in addition to the ceramic bypass capacitors.

7.5 Layout

7.5.1 Layout Guidelines

As for all switching power supplies, especially those high frequency and high current ones, layout is an important design step. If layout is not carefully done, the regulator could suffer from instability as well as noise problems. Therefore, use wide and short traces for high current paths. The input capacitor C_{IN} must be close to VIN pin and GND pin in order to reduce the input ripple seen by the device. If possible choose higher capacitance value for it. The SW pin carries high current with fast rising and falling edge; therefore, the connection between the SW pin to the inductor must be kept as short and wide as possible. The output capacitor C_{OUT} must be put close to VOUT pin. It is also beneficial to have the ground of C_{OUT} close to the GND pin because there is large ground return current flowing between them. FB resistor must be put close to FB pin. When laying out signal ground, TI recommends using short traces separated from power ground traces, and connect them together at a single point close to the GND pin.

7.5.2 Layout Example

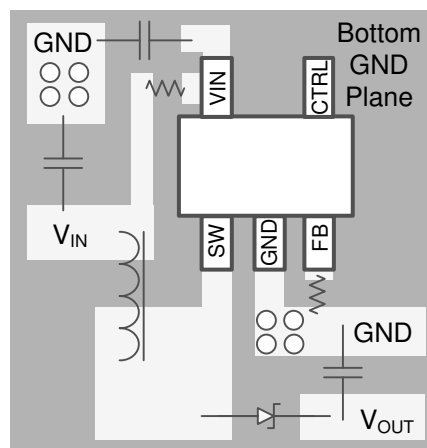

Figure 7-15. TPS61169 Board Layout

8 Device and Documentation Support

8.1 Device Support

8.2 Receiving Notification of Documentation Updates

To receive notification of documentation updates, navigate to the device product folder on ti.com. Click on *Notifications* to register and receive a weekly digest of any product information that has changed. For change details, review the revision history included in any revised document.

8.3 Support Resources

[TI E2E™ support forums](#) are an engineer's go-to source for fast, verified answers and design help — straight from the experts. Search existing answers or ask your own question to get the quick design help you need.

Linked content is provided "AS IS" by the respective contributors. They do not constitute TI specifications and do not necessarily reflect TI's views; see TI's [Terms of Use](#).

8.4 Trademarks

TI E2E™ is a trademark of Texas Instruments.
All trademarks are the property of their respective owners.

8.5 Electrostatic Discharge Caution



This integrated circuit can be damaged by ESD. Texas Instruments recommends that all integrated circuits be handled with appropriate precautions. Failure to observe proper handling and installation procedures can cause damage.

ESD damage can range from subtle performance degradation to complete device failure. Precision integrated circuits may be more susceptible to damage because very small parametric changes could cause the device not to meet its published specifications.

8.6 Glossary

[TI Glossary](#) This glossary lists and explains terms, acronyms, and definitions.

9 Revision History

NOTE: Page numbers for previous revisions may differ from page numbers in the current version.

Changes from Revision A (March 2016) to Revision B (June 2024)	Page
<hr/>	
Changes from Revision * (October 2014) to Revision A (March 2016)	
• Added new items to "Applications" on page 1	1
• Changed <i>Handling Ratings</i> to <i>ESD Ratings</i> table; move storage temperature range from <i>Handling Ratings</i> to <i>Abs Max</i> table	4

10 Mechanical, Packaging, and Orderable Information

The following pages include mechanical, packaging, and orderable information. This information is the most current data available for the designated devices. This data is subject to change without notice and revision of this document. For browser-based versions of this data sheet, refer to the left-hand navigation.

PACKAGING INFORMATION

Orderable part number	Status (1)	Material type (2)	Package Pins	Package qty Carrier	RoHS (3)	Lead finish/ Ball material (4)	MSL rating/ Peak reflow (5)	Op temp (°C)	Part marking (6)
TPS61169DCKR	Active	Production	SC70 (DCK) 5	3000 LARGE T&R	Yes	NIPDAU SN	Level-1-260C-UNLIM	-40 to 85	SZL
TPS61169DCKR.B	Active	Production	SC70 (DCK) 5	3000 LARGE T&R	Yes	SN	Level-1-260C-UNLIM	-40 to 85	SZL
TPS61169DCKRG4.B	Active	Production	SC70 (DCK) 5	3000 LARGE T&R	-	Call TI	Call TI	-40 to 85	

(1) Status: For more details on status, see our [product life cycle](#).

(2) Material type: When designated, preproduction parts are prototypes/experimental devices, and are not yet approved or released for full production. Testing and final process, including without limitation quality assurance, reliability performance testing, and/or process qualification, may not yet be complete, and this item is subject to further changes or possible discontinuation. If available for ordering, purchases will be subject to an additional waiver at checkout, and are intended for early internal evaluation purposes only. These items are sold without warranties of any kind.

(3) RoHS values: Yes, No, RoHS Exempt. See the [TI RoHS Statement](#) for additional information and value definition.

(4) Lead finish/Ball material: Parts may have multiple material finish options. Finish options are separated by a vertical ruled line. Lead finish/Ball material values may wrap to two lines if the finish value exceeds the maximum column width.

(5) MSL rating/Peak reflow: The moisture sensitivity level ratings and peak solder (reflow) temperatures. In the event that a part has multiple moisture sensitivity ratings, only the lowest level per JEDEC standards is shown. Refer to the shipping label for the actual reflow temperature that will be used to mount the part to the printed circuit board.

(6) Part marking: There may be an additional marking, which relates to the logo, the lot trace code information, or the environmental category of the part.

Multiple part markings will be inside parentheses. Only one part marking contained in parentheses and separated by a "-" will appear on a part. If a line is indented then it is a continuation of the previous line and the two combined represent the entire part marking for that device.

Important Information and Disclaimer: The information provided on this page represents TI's knowledge and belief as of the date that it is provided. TI bases its knowledge and belief on information provided by third parties, and makes no representation or warranty as to the accuracy of such information. Efforts are underway to better integrate information from third parties. TI has taken and continues to take reasonable steps to provide representative and accurate information but may not have conducted destructive testing or chemical analysis on incoming materials and chemicals. TI and TI suppliers consider certain information to be proprietary, and thus CAS numbers and other limited information may not be available for release.

In no event shall TI's liability arising out of such information exceed the total purchase price of the TI part(s) at issue in this document sold by TI to Customer on an annual basis.

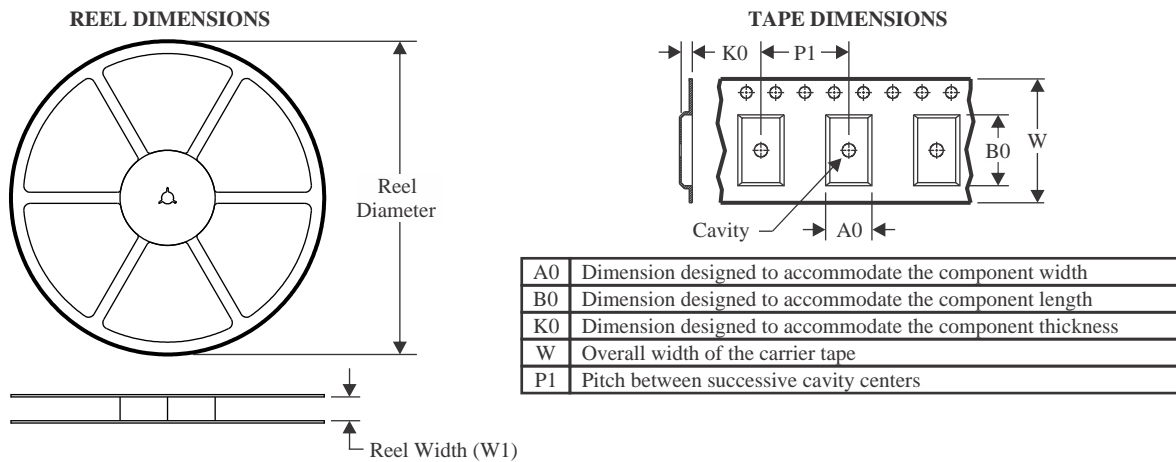
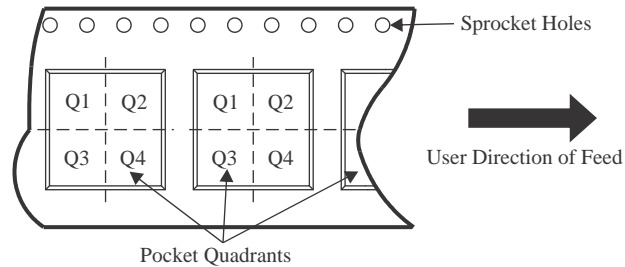
TAPE AND REEL INFORMATION

QUADRANT ASSIGNMENTS FOR PIN 1 ORIENTATION IN TAPE

*All dimensions are nominal

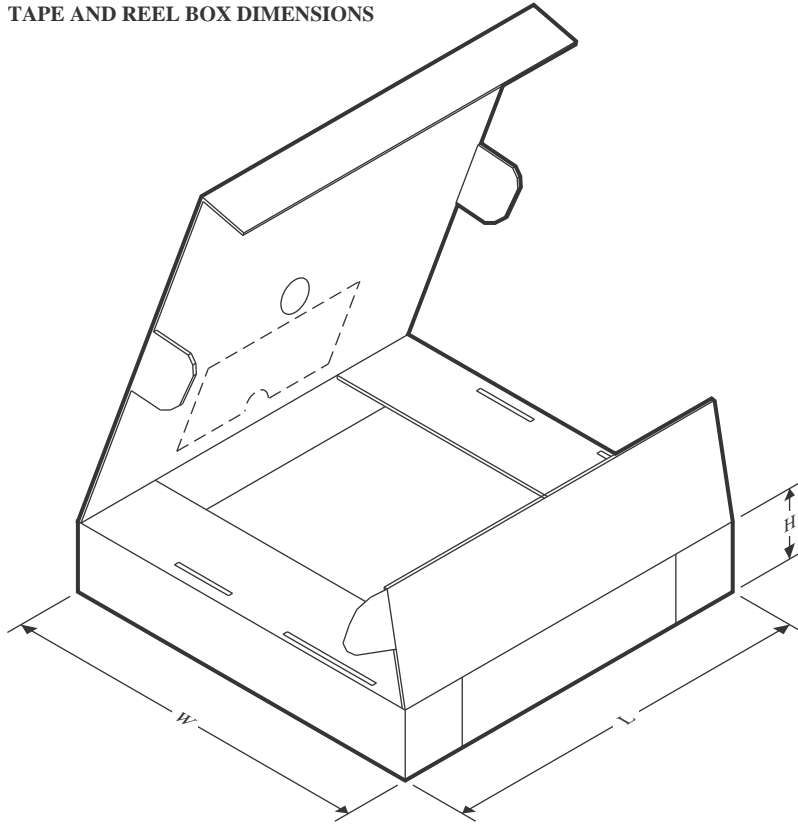
Device	Package Type	Package Drawing	Pins	SPQ	Reel Diameter (mm)	Reel Width W1 (mm)	A0 (mm)	B0 (mm)	K0 (mm)	P1 (mm)	W (mm)	Pin1 Quadrant
TPS61169DCKR	SC70	DCK	5	3000	180.0	8.4	2.3	2.55	1.2	4.0	8.0	Q3
TPS61169DCKR	SC70	DCK	5	3000	178.0	9.0	2.4	2.5	1.2	4.0	8.0	Q3

TAPE AND REEL BOX DIMENSIONS

*All dimensions are nominal

Device	Package Type	Package Drawing	Pins	SPQ	Length (mm)	Width (mm)	Height (mm)
TPS61169DCKR	SC70	DCK	5	3000	210.0	185.0	35.0
TPS61169DCKR	SC70	DCK	5	3000	180.0	180.0	18.0

DCK0005A



PACKAGE OUTLINE

SOT - 1.1 max height

SMALL OUTLINE TRANSISTOR

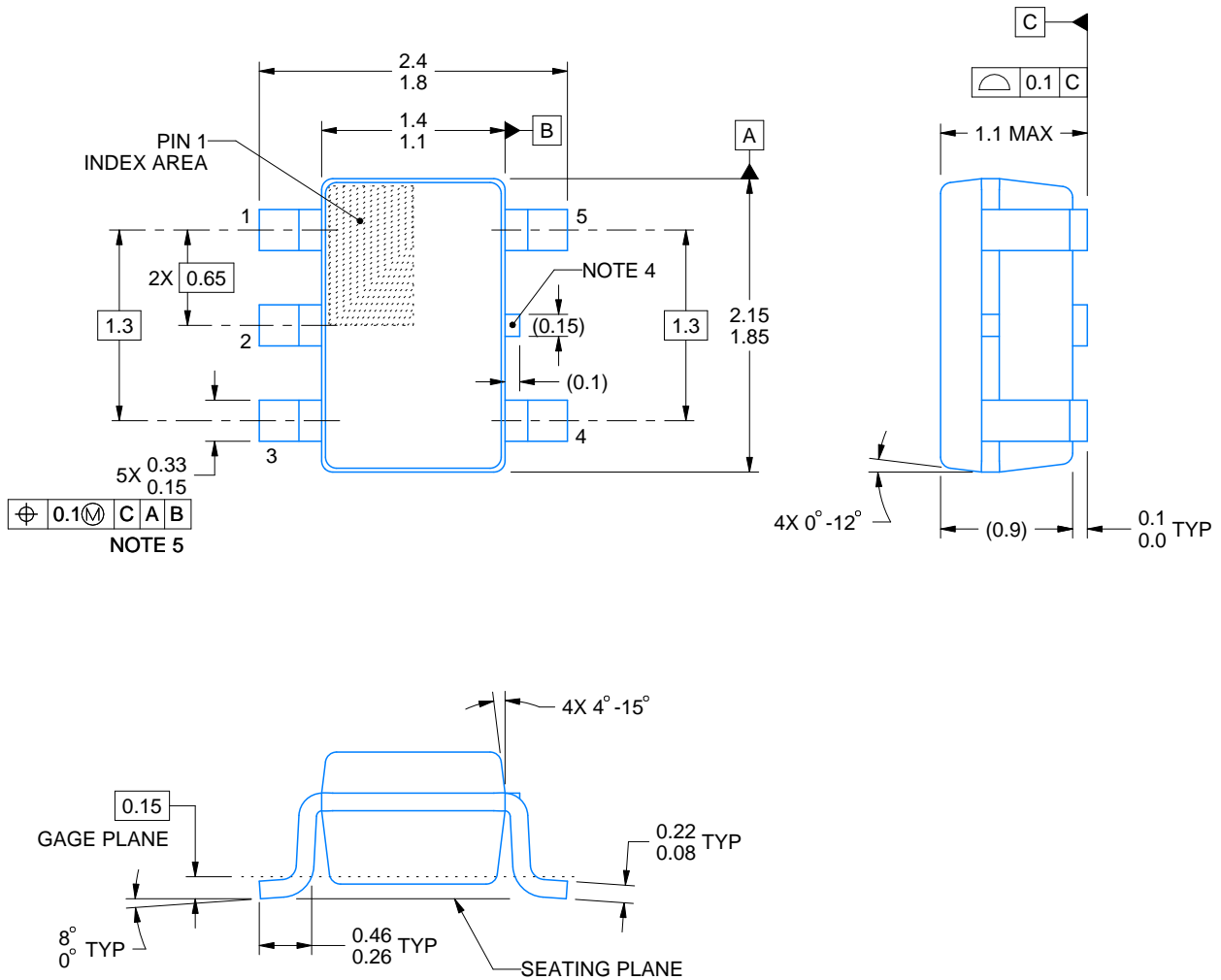

4214834/G 11/2024

NOTES:

1. All linear dimensions are in millimeters. Any dimensions in parenthesis are for reference only. Dimensioning and tolerancing per ASME Y14.5M.
2. This drawing is subject to change without notice.
3. Reference JEDEC MO-203.
4. Support pin may differ or may not be present.
5. Lead width does not comply with JEDEC.
6. Body dimensions do not include mold flash, protrusions, or gate burrs. Mold flash, protrusions, or gate burrs shall not exceed 0.25mm per side

EXAMPLE BOARD LAYOUT

DCK0005A

SOT - 1.1 max height

SMALL OUTLINE TRANSISTOR

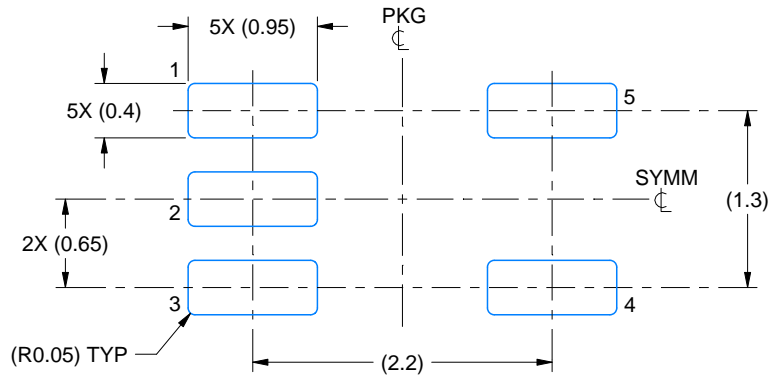

LAND PATTERN EXAMPLE
EXPOSED METAL SHOWN
SCALE:18X

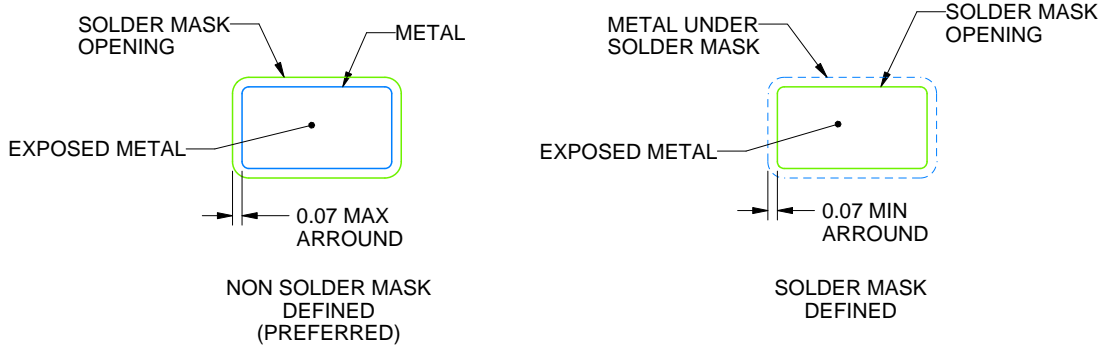

SOLDER MASK DETAILS

4214834/G 11/2024

NOTES: (continued)

- 7. Publication IPC-7351 may have alternate designs.
- 8. Solder mask tolerances between and around signal pads can vary based on board fabrication site.

EXAMPLE STENCIL DESIGN

DCK0005A

SOT - 1.1 max height

SMALL OUTLINE TRANSISTOR

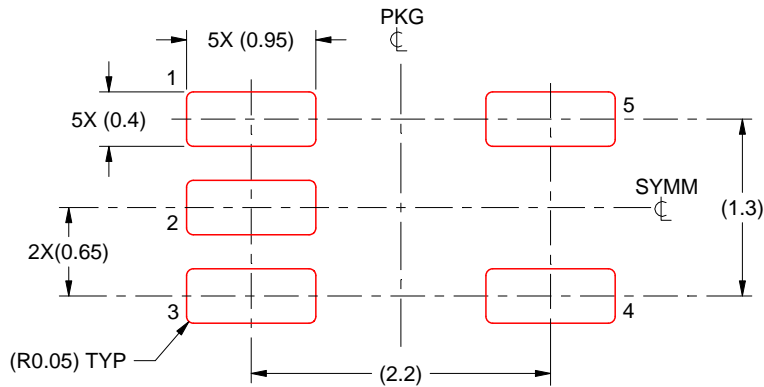

SOLDER PASTE EXAMPLE
BASED ON 0.125 THICK STENCIL
SCALE:18X

4214834/G 11/2024

NOTES: (continued)

9. Laser cutting apertures with trapezoidal walls and rounded corners may offer better paste release. IPC-7525 may have alternate design recommendations.
10. Board assembly site may have different recommendations for stencil design.

IMPORTANT NOTICE AND DISCLAIMER

TI PROVIDES TECHNICAL AND RELIABILITY DATA (INCLUDING DATASHEETS), DESIGN RESOURCES (INCLUDING REFERENCE DESIGNS), APPLICATION OR OTHER DESIGN ADVICE, WEB TOOLS, SAFETY INFORMATION, AND OTHER RESOURCES "AS IS" AND WITH ALL FAULTS, AND DISCLAIMS ALL WARRANTIES, EXPRESS AND IMPLIED, INCLUDING WITHOUT LIMITATION ANY IMPLIED WARRANTIES OF MERCHANTABILITY, FITNESS FOR A PARTICULAR PURPOSE OR NON-INFRINGEMENT OF THIRD PARTY INTELLECTUAL PROPERTY RIGHTS.

These resources are intended for skilled developers designing with TI products. You are solely responsible for (1) selecting the appropriate TI products for your application, (2) designing, validating and testing your application, and (3) ensuring your application meets applicable standards, and any other safety, security, regulatory or other requirements.

These resources are subject to change without notice. TI grants you permission to use these resources only for development of an application that uses the TI products described in the resource. Other reproduction and display of these resources is prohibited. No license is granted to any other TI intellectual property right or to any third party intellectual property right. TI disclaims responsibility for, and you fully indemnify TI and its representatives against any claims, damages, costs, losses, and liabilities arising out of your use of these resources.

TI's products are provided subject to [TI's Terms of Sale](#), [TI's General Quality Guidelines](#), or other applicable terms available either on [ti.com](#) or provided in conjunction with such TI products. TI's provision of these resources does not expand or otherwise alter TI's applicable warranties or warranty disclaimers for TI products. Unless TI explicitly designates a product as custom or customer-specified, TI products are standard, catalog, general purpose devices.

TI objects to and rejects any additional or different terms you may propose.

Copyright © 2026, Texas Instruments Incorporated

Last updated 10/2025