

OPAx187 0.001- $\mu\text{V}/^\circ\text{C}$ Drift, Low Power, Rail-to-Rail Output 36-V Operational Amplifiers Zero-Drift Series

1 Features

- Low offset voltage: 10 μV (maximum)
- Zero drift: 0.001 $\mu\text{V}/^\circ\text{C}$
- Low noise: 15 $\text{nV}/\sqrt{\text{Hz}}$
- PSRR: 160 dB
- CMRR: 140 dB
- AOL: 160 dB
- Quiescent Current: 100 μA
- Wide supply voltage: $\pm 2.25\text{ V}$ to $\pm 18\text{ V}$
- Rail-to-rail output operation
- Input includes negative rail
- Low bias current: 100 pA (typical)
- EMI filtered inputs
- Microsize packages

2 Applications

- [Analog input module](#)
- [Mixed module \(AI, AO, DI, DO\)](#)
- [Flow transmitter](#)
- [Pressure transmitter](#)
- [Test and measurement](#)
- [Semiconductor test](#)
- [Semiconductor manufacturing](#)
- [Process analytics \(pH, gas, concentration, force, and humidity\)](#)

3 Description

The OPAx187 series operational amplifiers use auto-zeroing techniques to simultaneously provide low-offset voltage (1 μV), and near zero drift over time and temperature. These miniature, high-precision, low-quiescent current amplifiers offer high-input impedance and rail-to-rail output swing within 5 mV of the rails into high-impedance loads. The input common-mode range includes the negative rail. Either single or dual supplies can be used in the range of 4.5 V to 36 V ($\pm 2.25\text{ V}$ to $\pm 18\text{ V}$).

The single version OPAx187 device is available in microsize 8-pin VSSOP, 5-pin SOT-23, and 8-pin SOIC packages. The dual version is offered in 8-pin VSSOP and 8-pin SOIC packages. The quad version is offered in 14-pin SOIC, 14-pin TSSOP, and 16-pin WQFN packages. All versions are specified for operation from -40°C to $+125^\circ\text{C}$.

Device Information⁽¹⁾

PART NUMBER	PACKAGE	BODY SIZE (NOM)
OPA187	SOIC (8)	4.90 mm x 3.91 mm
	SOT-23 (5)	2.90 mm x 1.60 mm
	VSSOP (8)	3.00 mm x 3.00 mm
OPA2187	SOIC (8)	4.90 mm x 3.91 mm
	VSSOP (8)	3.00 mm x 3.00 mm
OPA4187	SOIC (14)	8.70 mm x 3.90 mm
	TSSOP (14)	5.00 mm x 4.40 mm
	WQFN (16)	4.00 mm x 4.00 mm

(1) For all available packages, see the package option addendum at the end of the data sheet.

OPAx187 Offers Precision Low-Side Current Measurement Capability

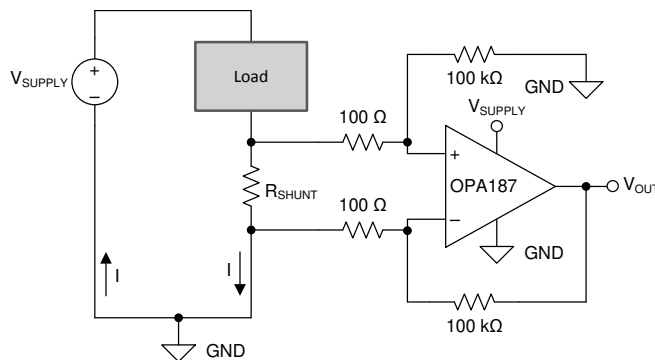

$$G = 1000 \cdot R_{\text{SHUNT}} \cdot I$$



Table of Contents

1 Features	1	7.4 Device Functional Modes.....	21
2 Applications	1	8 Application and Implementation	22
3 Description	1	8.1 Application Information.....	22
4 Revision History	2	8.2 Typical Applications	22
5 Pin Configuration and Functions	4	9 Power Supply Recommendations	26
6 Specifications	6	10 Layout	27
6.1 Absolute Maximum Ratings	6	10.1 Layout Guidelines	27
6.2 ESD Ratings.....	6	10.2 Layout Example	27
6.3 Recommended Operating Conditions.....	6	11 Device and Documentation Support	28
6.4 Thermal Information: OPA187	7	11.1 Device Support	28
6.5 Thermal Information: OPA2187	7	11.2 Documentation Support	28
6.6 Thermal Information: OPA4187	7	11.3 Related Links	29
6.7 Electrical Characteristics: High-Voltage Operation..	8	11.4 Receiving Notification of Documentation Updates	29
6.8 Electrical Characteristics: Low-Voltage Operation...	9	11.5 Support Resources	29
6.9 Typical Characteristics	10	11.6 Trademarks	29
7 Detailed Description	17	11.7 Electrostatic Discharge Caution.....	29
7.1 Overview	17	11.8 Glossary	29
7.2 Functional Block Diagram	17	12 Mechanical, Packaging, and Orderable	29
7.3 Feature Description.....	18	Information	29

4 Revision History

NOTE: Page numbers for previous revisions may differ from page numbers in the current version.

Changes from Revision D (December 2018) to Revision E	Page
• Changed OPA4187 RUM (WQFN) package from preview to production data (active)	1

Changes from Revision C (December 2018) to Revision D	Page
• Changed OPA4187 SOIC and TSSOP packages from product preview to production data	1
• Changed offset drift (high and low supply) max to $\pm 15\text{nV}/^\circ\text{C}$	9

Changes from Revision B (October 2018) to Revision C	Page
• First release of production OPA187 SOIC device	1

Changes from Revision A (July 2017) to Revision B	Page
• Changed OPA187 SOIC status to preview	1
• Changed OPA4187 SOIC, TSSOP and WQFN status to preview	1
• Changed offset drift (high supply) typical from $\pm 5\text{ nV}/^\circ\text{C}$ to $\pm 1\text{ nV}/^\circ\text{C}$ and max from $\pm 50\text{ nV}/^\circ\text{C}$ to $\pm 20\text{ nV}/^\circ\text{C}$	8
• Changed input bias current max (high supply) from $\pm 5\text{ nA}$ to $\pm 7.5\text{ nA}$	8
• Changed input offset current max (high supply) from $\pm 5\text{ nA}$ to $\pm 14.5\text{ nA}$	8
• Changed offset drift (low supply) typical from $\pm 5\text{ nV}/^\circ\text{C}$ to $\pm 1\text{ nV}/^\circ\text{C}$ and max from $\pm 50\text{ nV}/^\circ\text{C}$ to $\pm 20\text{ nV}/^\circ\text{C}$	9
• Changed Offset Voltage Production Distribution figure	11

Changes from Original (December 2016) to Revision A	Page
• Deleted VSON package option from the Description	1
• Deleted VSON package option from the <i>Device Information</i> table	1
• Added WQFN package option to the <i>Device Information</i> table.....	1
• Deleted OPA187 DRG package option from <i>Pin Configuration and Functions</i>	4
• Added WQFN package to <i>Pin Configuration and Functions</i>	5

5 Pin Configuration and Functions

OPA187: DBV Package
5-Pin SOT-23
Top View

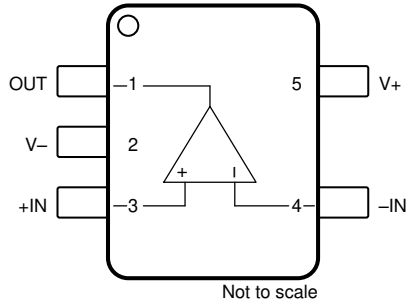

OPA187: D and DGK Packages
8-Pin SOIC and 8-pin VSSOP
Top View

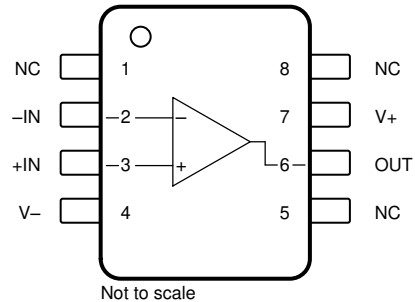

Pin Functions: OPA187

NAME	PIN		I/O	DESCRIPTION
	DBV	D and DGK		
+IN	3	3	I	Non-inverting input
-IN	4	2	I	Inverting input
NC	—	1, 5, 8	—	No connection (can be left floating)
OUT	1	6	O	Output signal
V+	5	7	—	Positive (highest) supply voltage
V-	2	4	—	Negative (lowest) supply voltage

OPA2187: D and DGK Packages
8-Pin SOIC and 8-Pin VSSOP
Top View

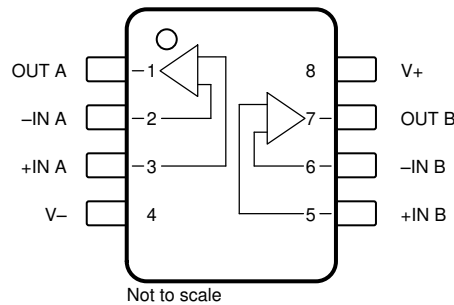

Pin Functions: OPA2187

NAME	PIN		I/O	DESCRIPTION
	D and DGK			
+IN A	3	3	I	Non-inverting input, channel A
-IN A	2	2	I	Inverting input, channel A
+IN B	5	5	I	Non-inverting input, channel B
-IN B	6	6	I	Inverting input, channel B
OUT A	1	1	O	Output, channel A
OUT B	7	7	O	Output, channel B
V+	8	8	—	Positive (highest) supply voltage
V-	4	4	—	Negative (lowest) supply voltage

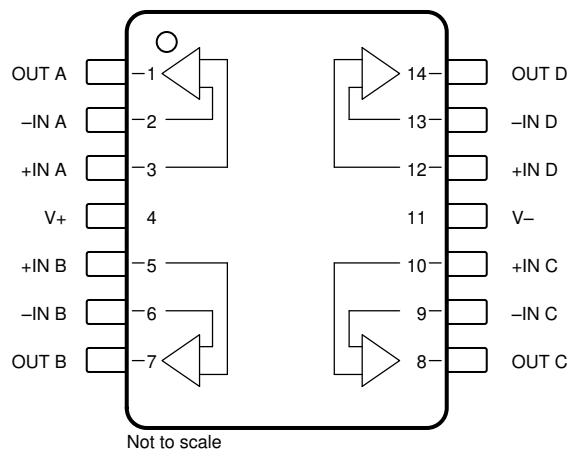
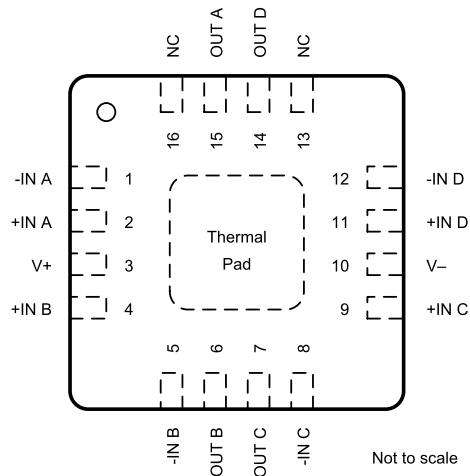
**OPA4187: D and PW Packages
14-pin SOIC and 14-Pin TSSOP
Top View**

**OPA4187: RUM Package
16-pin WQFN
Top View**

Pin Functions: OPA4187

NAME	PIN		I/O	DESCRIPTION
	D and PW	RUM		
+IN A	3	2	I	Non-inverting input, channel A
-IN A	2	1	I	Inverting input, channel A
+IN B	5	4	I	Non-inverting input, channel B
-IN B	6	5	I	Inverting input, channel B
+IN C	10	9	I	Non-inverting input, channel C
-IN C	9	8	I	Inverting input, channel C
+IN D	12	11	I	Non-inverting input, channel D
-IN D	13	12	I	Inverting input, channel D
OUT A	1	15	O	Output, channel A
OUT B	7	6	O	Output, channel B
OUT C	8	7	O	Output, channel C
OUT D	14	14	O	Output, channel D
V+	4	3	—	Positive (highest) supply voltage
V-	11	10	—	Negative (lowest) supply voltage
NC	—	13, 16	—	No internal connection (can be left floating)

6 Specifications

6.1 Absolute Maximum Ratings

over operating free-air temperature range (unless otherwise noted)⁽¹⁾

		MIN	MAX	UNIT
Voltage	Supply, $V_S = (V^+) - (V^-)$		40	
	Signal input pin ⁽²⁾	$(V^-) - 0.5$	$(V^+) + 0.5$	V
	Signal output pin ⁽³⁾	$(V^-) - 0.5$	$(V^+) + 0.5$	
Current	Signal input pin ⁽²⁾	-10	10	mA
	Signal output pin ⁽³⁾	-55	55	mA
	Output short-circuit ⁽⁴⁾	Continuous	Continuous	
Temperature	Operating range, T_A	-55	150	
	Junction, T_J		150	°C
	Storage, T_{sig}	-65	150	

- (1) Stresses beyond those listed under *Absolute Maximum Ratings* may cause permanent damage to the device. These are stress ratings only, which do not imply functional operation of the device at these or any other conditions beyond those indicated under *Recommended Operating Conditions*. Exposure to absolute-maximum-rated conditions for extended periods may affect device reliability.
- (2) Input terminals are diode-clamped to the power-supply rails. Input signals that can swing more than 0.5 V beyond the supply rails should be current limited to ± 10 mA or less.
- (3) Output terminals are diode-clamped to the power-supply rails. Output signals that can swing more than 0.5 V beyond the supply rails should be current limited to ± 55 mA or less.
- (4) Short-circuit to ground, one amplifier per package.

6.2 ESD Ratings

			VALUE	UNIT
$V_{(ESD)}$	Electrostatic discharge	Human-body model (HBM), per ANSI/ESDA/JEDEC JS-001 ⁽¹⁾	± 4000	V
		Charged-device model (CDM), per JEDEC specification JESD22-C101 ⁽²⁾	± 1500	

- (1) JEDEC document JEP155 states that 500-V HBM allows safe manufacturing with a standard ESD control process.
- (2) JEDEC document JEP157 states that 250-V CDM allows safe manufacturing with a standard ESD control process.

6.3 Recommended Operating Conditions

over operating free-air temperature range (unless otherwise noted)

		MIN	NOM	MAX	UNIT
$(V^+) - (V^-)$	Supply voltage	4.5 (± 2.25)		36 (± 18)	V
T_A	Operating temperature	-40		150	°C

6.4 Thermal Information: OPA187

THERMAL METRIC ⁽¹⁾		OPA187			UNIT
		5 PINS		8 PINS	
		DBV (SOT-23)	DGK (VSSOP)	D (SOIC)	
$R_{\theta JA}$	Junction-to-ambient thermal resistance	273.8	159	100.1	°C/W
$R_{\theta JC(top)}$	Junction-to-case (top) thermal resistance	126.8	37	42.4	°C/W
$R_{\theta JB}$	Junction-to-board thermal resistance	85.9	49	41.0	°C/W
Ψ_{JT}	Junction-to-top characterization parameter	10.9	1.2	4.8	°C/W
Ψ_{JB}	Junction-to-board characterization parameter	84.9	77.1	40.3	°C/W
$R_{\theta JC(bot)}$	Junction-to-case (bottom) thermal resistance	n/a	n/a	n/a	°C/W

- (1) For more information about traditional and new thermal metrics, see the [Semiconductor and IC Package Thermal Metrics](#) application report.

6.5 Thermal Information: OPA2187

THERMAL METRIC ⁽¹⁾		OPA2187		UNIT
		8 PINS		
		DGK (VSSOP)	D (SOIC)	
$R_{\theta JA}$	Junction-to-ambient thermal resistance	159	100.1	°C/W
$R_{\theta JC(top)}$	Junction-to-case (top) thermal resistance	37	42.4	°C/W
$R_{\theta JB}$	Junction-to-board thermal resistance	49	41.0	°C/W
Ψ_{JT}	Junction-to-top characterization parameter	1.2	4.8	°C/W
Ψ_{JB}	Junction-to-board characterization parameter	77.1	40.3	°C/W
$R_{\theta JC(bot)}$	Junction-to-case (bottom) thermal resistance	n/a	n/a	°C/W

- (1) For more information about traditional and new thermal metrics, see the [Semiconductor and IC Package Thermal Metrics](#) application report.

6.6 Thermal Information: OPA4187

THERMAL METRIC ⁽¹⁾		OPA4187			UNIT
		14 PINS		16 PINS	
		PW (TSSOP)	D (SOIC)	RUM (WQFN)	
$R_{\theta JA}$	Junction-to-ambient thermal resistance	107.8	83.8	35.3	°C/W
$R_{\theta JC(top)}$	Junction-to-case (top) thermal resistance	29.6	70.7	32.7	°C/W
$R_{\theta JB}$	Junction-to-board thermal resistance	52.6	59.5	12.9	°C/W
Ψ_{JT}	Junction-to-top characterization parameter	1.5	11.6	0.3	°C/W
Ψ_{JB}	Junction-to-board characterization parameter	51.6	37.7	12.9	°C/W
$R_{\theta JC(bot)}$	Junction-to-case (bottom) thermal resistance	n/a	n/a	3.3	°C/W

- (1) For more information about traditional and new thermal metrics, see the [Semiconductor and IC Package Thermal Metrics](#) application report.

6.7 Electrical Characteristics: High-Voltage Operation

at $T_A = +25^\circ\text{C}$, $V_S = \pm 4\text{ V}$ to $\pm 18\text{ V}$ ($V_S = +8\text{ V}$ to $+36\text{ V}$), $R_L = 10\text{ k}\Omega$ connected to $V_S / 2^{(1)}$, and $V_{CM} = V_{OUT} = V_S / 2^{(1)}$ (unless otherwise noted)

PARAMETER		CONDITIONS	MIN	TYP	MAX	UNIT
OFFSET VOLTAGE						
V_{OS}	Input offset voltage			± 1	± 10	μV
		$T_A = -40^\circ\text{C}$ to $+125^\circ\text{C}$		± 0.001	± 0.015	$\mu\text{V}/^\circ\text{C}$
PSRR	Power-supply rejection ratio	$V_S = 4.5\text{ V}$ to 36 V , $T_A = -40^\circ\text{C}$ to $+125^\circ\text{C}$		± 0.01	± 1	$\mu\text{V}/\text{V}$
INPUT BIAS CURRENT						
I_B	Input bias current	$V_{CM} = V_S / 2$		± 100	± 350	pA
		$T_A = -40^\circ\text{C}$ to $+125^\circ\text{C}$			± 7.5	nA
I_{OS}	Input offset current			± 100	± 500	pA
		$T_A = -40^\circ\text{C}$ to $+125^\circ\text{C}$			± 14.5	nA
NOISE						
e_n	Input voltage noise	$f = 0.1\text{ Hz}$ to 10 Hz		0.4		μV_{PP}
		$f = 0.1\text{ Hz}$ to 10 Hz		60		nV_{rms}
	Input voltage noise density	$f = 1\text{ kHz}$		20		$\text{nV}/\sqrt{\text{Hz}}$
i_n	Input current noise density	$f = 1\text{ kHz}$		160		$\text{fA}/\sqrt{\text{Hz}}$
INPUT VOLTAGE RANGE						
V_{CM}	Common-mode voltage range		$(V-) - 0.1$		$(V+) - 2$	V
CMRR	Common-mode rejection ratio	$(V-) - 0.1\text{ V} < V_{CM} < (V+) - 2\text{ V}$, $V_S = \pm 18\text{ V}$	126	140		dB
		$(V-) < V_{CM} < (V+) - 2\text{ V}$, $V_S = \pm 18\text{ V}$, $T_A = -40^\circ\text{C}$ to $+125^\circ\text{C}$	130	145		dB
INPUT IMPEDANCE						
Z_{ID}	Differential			$100 \parallel 6$		$\text{M}\Omega \parallel \text{pF}$
Z_{IC}	Common-mode			$6 \parallel 4.2$		$10^{12}\ \Omega \parallel \text{pF}$
OPEN-LOOP GAIN						
A_{OL}	Open-loop voltage gain	$T_A = -40^\circ\text{C}$ to $+125^\circ\text{C}$, $V_S = \pm 4\text{ V}$ to $\pm 18\text{ V}$, $(V-) + 0.3\text{ V} < V_O < (V+) - 0.3\text{ V}$, $R_L = 10\text{ k}\Omega$	132	160		dB
FREQUENCY RESPONSE						
GBW	Gain-bandwidth product			550		kHz
SR	Slew rate	$V_O = 10\text{-V}$ step, $G = +1$		0.2		$\text{V}/\mu\text{s}$
t_S	Settling time	0.1%	$V_S = \pm 18\text{ V}$, $G = 1$, 10-V step	46		μs
		0.01%	$V_S = \pm 18\text{ V}$, $G = 1$, 10-V step	48		μs
t_{OR}	Overload recovery time	$V_{IN} \times G = V_S$		8		μs
THD+N	Total harmonic distortion + noise	1 kHz, $G = +1$, $V_{OUT} = 3.5\text{ V}_{RMS}$, No Load		0.035%		
OUTPUT						
	Voltage output swing from rail	$V_S = \pm 4\text{ V}$ to $\pm 18\text{ V}$, No Load		5	15	mV
		$V_S = \pm 4\text{ V}$ to $\pm 18\text{ V}$, $R_L = 10\text{ k}\Omega$		75	100	
		$V_S = \pm 4\text{ V}$ to $\pm 18\text{ V}$, $R_L = 10\text{ k}\Omega$, $T_A = -40^\circ\text{C}$ to $+125^\circ\text{C}$		100	125	
I_{SC}	Short-circuit current	$V_S = \pm 18\text{ V}$, Sinking		-30		mA
		$V_S = \pm 18\text{ V}$, Sourcing		+30		mA
R_O	Open-loop output resistance	$f = 550\text{ kHz}$, $I_O = 0$, See Figure 21		1.4		$\text{k}\Omega$
C_{LOAD}	Capacitive load drive			See Typical Characteristics		
POWER SUPPLY						
I_Q	Quiescent current (per amplifier)	$V_S = \pm 4\text{ V}$ to $V_S = \pm 18\text{ V}$		100	145	μA
		$I_O = 0\text{ mA}$, $T_A = -40^\circ\text{C}$ to $+125^\circ\text{C}$				150

(1) $V_S / 2 = \text{midsupply}$.

6.8 Electrical Characteristics: Low-Voltage Operation

at $T_A = +25^\circ\text{C}$, $V_S = \pm 2.25\text{ V}$ to $< \pm 4\text{ V}$ ($V_S = +4.5\text{ V}$ to $< +8\text{ V}$), $R_L = 10\text{ k}\Omega$ connected to $V_S / 2^{(1)}$, and $V_{CM} = V_{OUT} = V_S / 2^{(1)}$ (unless otherwise noted)

PARAMETER		CONDITIONS	MIN	TYP	MAX	UNIT
OFFSET VOLTAGE						
V_{OS}	Input offset voltage			± 1	± 15	μV
		$T_A = -40^\circ\text{C}$ to $+125^\circ\text{C}$		± 0.001	± 0.015	$\mu\text{V}/^\circ\text{C}$
PSRR	Power-supply rejection ratio	$V_S = 4.5\text{ V}$ to 36 V , $T_A = -40^\circ\text{C}$ to $+125^\circ\text{C}$		± 0.01	± 1	$\mu\text{V}/\text{V}$
INPUT BIAS CURRENT						
I_B	Input bias current	$V_{CM} = V_S / 2$		± 100	± 350	pA
		$T_A = -40^\circ\text{C}$ to $+125^\circ\text{C}$			± 5	nA
I_{OS}	Input offset current			± 100	± 500	pA
		$T_A = -40^\circ\text{C}$ to $+125^\circ\text{C}$			± 5	nA
NOISE						
e_n	Input voltage noise	$f = 0.1\text{ Hz}$ to 10 Hz		0.4		μV_{PP}
		$f = 0.1\text{ Hz}$ to 10 Hz		60		nV_{RMS}
	Input voltage noise density	$f = 1\text{ kHz}$		20		$\text{nV}/\sqrt{\text{Hz}}$
i_n	Input current noise density	$f = 1\text{ kHz}$		160		$\text{fA}/\sqrt{\text{Hz}}$
INPUT VOLTAGE RANGE						
V_{CM}	Common-mode voltage range		$(V-) - 0.1$		$(V+) - 2$	V
CMRR	Common-mode rejection ratio	$(V-) - 0.1\text{ V} < V_{CM} < (V+) - 2\text{ V}$, $V_S = \pm 2.25\text{ V}$	114	130		dB
		$(V-) < V_{CM} < (V+) - 2\text{ V}$, $V_S = \pm 2.25\text{ V}$, $T_A = -40^\circ\text{C}$ to $+125^\circ\text{C}$	120	137		dB
INPUT IMPEDANCE						
Z_{ID}	Differential			$100 \parallel 6$		$\text{M}\Omega \parallel \text{pF}$
Z_{IC}	Common-mode			$6 \parallel 4.2$		$10^{12}\ \Omega \parallel \text{pF}$
OPEN-LOOP GAIN						
A_{OL}	Open-loop voltage gain	$T_A = -40^\circ\text{C}$ to $+125^\circ\text{C}$, $V_S = \pm 2.25\text{ V}$ to $\pm 4\text{ V}$, $(V-) + 0.3\text{ V} < V_O < (V+) - 0.3\text{ V}$, $R_L = 10\text{ k}\Omega$	120	140		dB
FREQUENCY RESPONSE						
GBW	Gain-bandwidth product			550		kHz
SR	Slew rate	$V_O = 1\text{-V}$ step, $G = +1$		0.2		$\text{V}/\mu\text{s}$
t_{OR}	Overload recovery time	$V_{IN} \times G = V_S$		8		μs
THD+N	Total harmonic distortion + noise	1 kHz, $G = +1$, $V_{OUT} = 1\text{ V}_{RMS}$, No Load		0.05%		
OUTPUT						
	Voltage output swing from rail	$V_S = \pm 2.25\text{ V}$ to $\pm 4\text{ V}$, No Load		5	15	mV
		$V_S = \pm 2.25\text{ V}$ to $\pm 4\text{ V}$, $R_L = 10\text{ k}\Omega$		15	25	
		$V_S = \pm 2.25\text{ V}$ to $\pm 4\text{ V}$, $R_L = 10\text{ k}\Omega$, $T_A = -40^\circ\text{C}$ to $+125^\circ\text{C}$		15	30	
I_{SC}	Short-circuit current	$V_S = \pm 2.25$, Sinking		-20		mA
		$V_S = \pm 2.25$, Sourcing		+20		mA
R_O	Open-loop output resistance	$f = 550\text{ kHz}$, $I_O = 0$, See Figure 21		1.4		$\text{k}\Omega$
C_{LOAD}	Capacitive load drive			See Typical Characteristics		
POWER SUPPLY						
I_Q	Quiescent current (per amplifier)	$V_S = \pm 2.25\text{ V}$ to $V_S = \pm 4\text{ V}$		100	145	μA
		$I_O = 0\text{ mA}$, $T_A = -40^\circ\text{C}$ to $+125^\circ\text{C}$				150

(1) $V_S / 2 = \text{midsupply}$.

6.9 Typical Characteristics

Table 1. Typical Characteristic Graphs

DESCRIPTION	FIGURE
Offset Voltage Production Distribution	Figure 1
Offset Voltage Drift Distribution	Figure 2
Offset Voltage vs Temperature	Figure 3
Offset Voltage vs Common-Mode Voltage	Figure 4
Offset Voltage vs Power Supply	Figure 5
Open-Loop Gain and Phase vs Frequency	Figure 6
Closed-Loop Gain vs Frequency	Figure 7
I_B vs Common-Mode Voltage	Figure 8
Input Bias Current vs Temperature	Figure 9
Output Voltage Swing vs Output Current	Figure 10
CMRR and PSRR vs Frequency (Referred-to-Input)	Figure 11
CMRR vs Temperature	Figure 12
PSRR vs Temperature	Figure 13
0.1-Hz to 10-Hz Noise	Figure 14
Input Voltage Noise Spectral Density vs Frequency	Figure 15
THD+N Ratio vs Frequency	Figure 16
THD+N vs Output Amplitude	Figure 17
Quiescent Current vs Supply Voltage	Figure 18
Quiescent Current vs Temperature	Figure 19
Open-Loop Gain vs Temperature	Figure 20
Open-Loop Output Impedance vs Frequency	Figure 21
Small-Signal Overshoot vs Capacitive Load ($G = 1$) (10-mV Output Step)	Figure 22
No Phase Reversal	Figure 23
Positive Overload Recovery	Figure 24
Negative Overload Recovery	Figure 25
Small-Signal Step Response (10 mV)	Figure 26, Figure 27
Large-Signal Step Response	Figure 28, Figure 29
Large-Signal Settling Time (10-V Positive Step)	Figure 30
Large-Signal Settling Time (10-V Negative Step)	Figure 31
Short-Circuit Current vs Temperature	Figure 32
Maximum Output Voltage vs Frequency	Figure 33
Crosstalk vs Frequency	Figure 34
EMIRR IN+ vs Frequency	Figure 35

at $V_S = \pm 18\text{ V}$, $V_{CM} = V_S / 2$, $R_{LOAD} = 10\text{ k}\Omega$ connected to $V_S / 2$, and $C_L = 100\text{ pF}$ (unless otherwise noted)

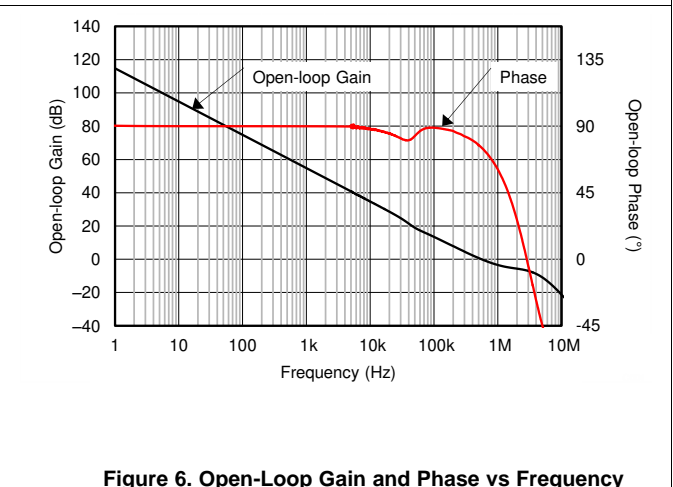
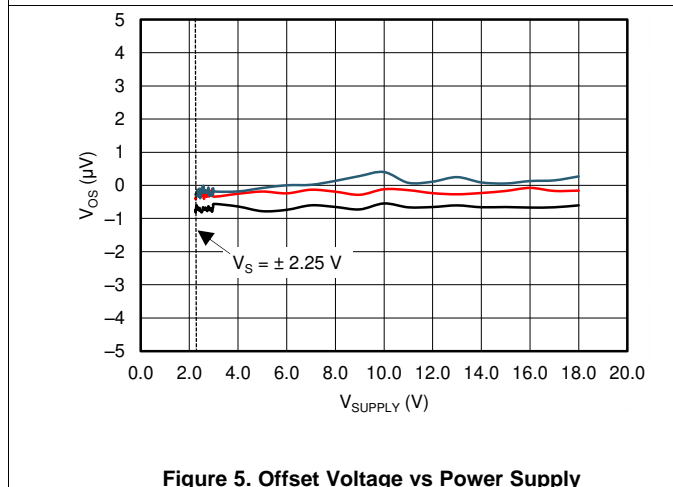
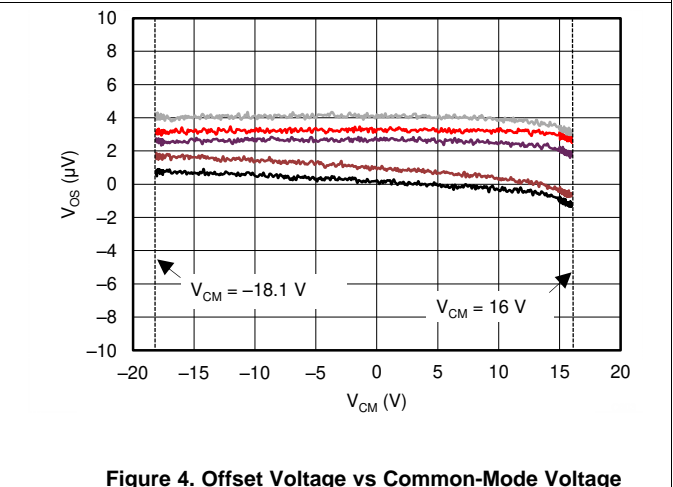
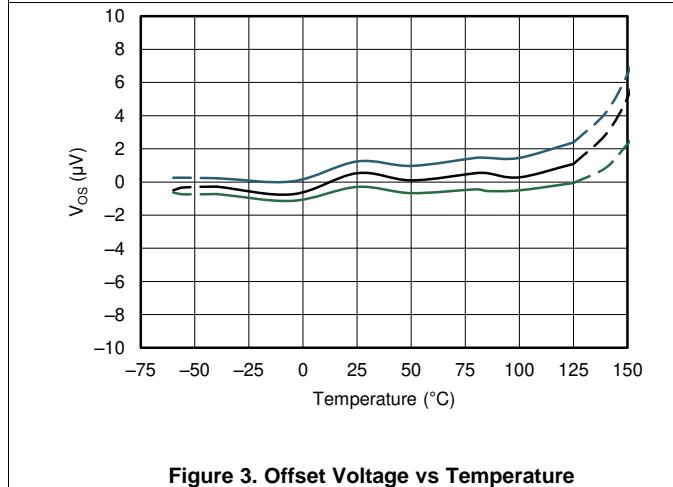
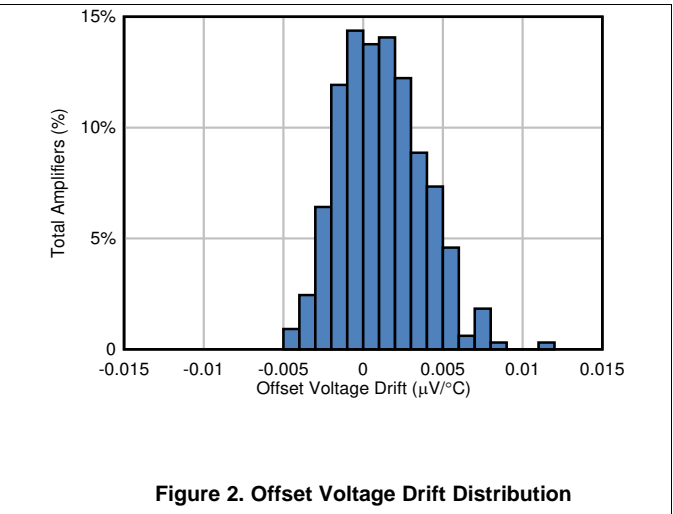
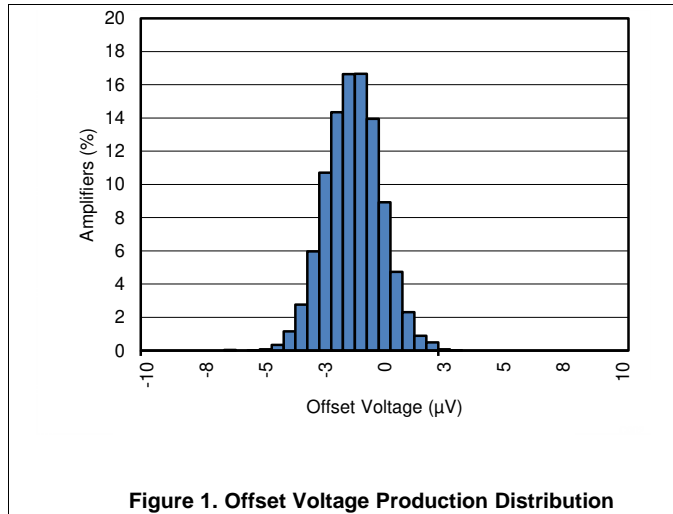

at $V_S = \pm 18\text{ V}$, $V_{CM} = V_S / 2$, $R_{LOAD} = 10\text{ k}\Omega$ connected to $V_S / 2$, and $C_L = 100\text{ pF}$ (unless otherwise noted)

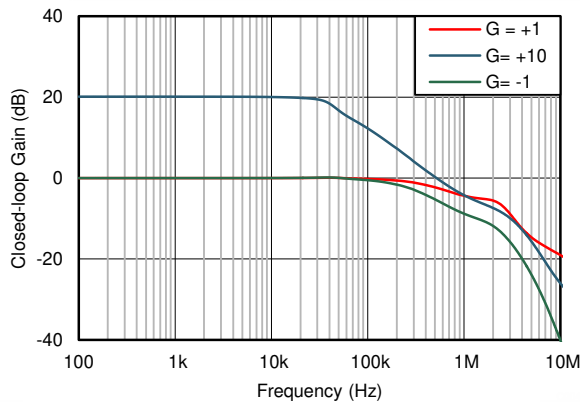

Figure 7. Closed-Loop Gain vs Frequency

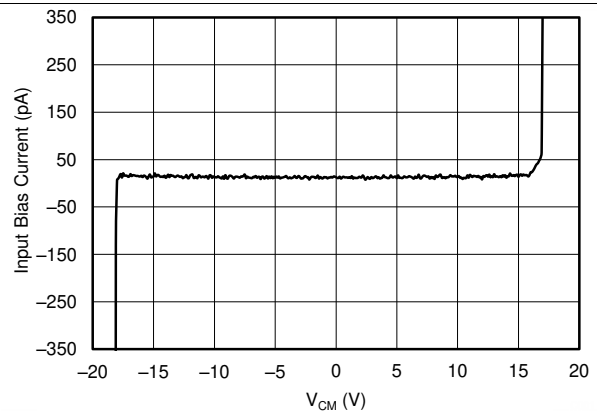

Figure 8. I_B vs Common-Mode Voltage

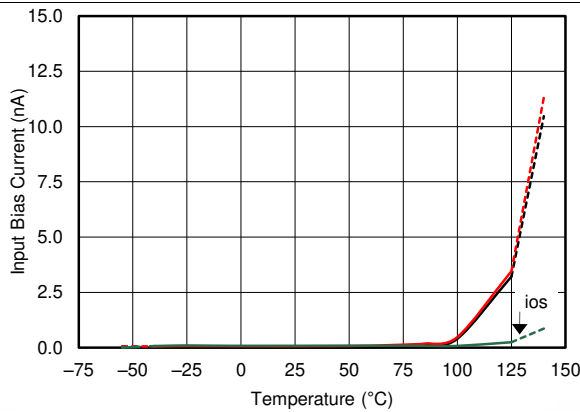

Figure 9. Input Bias Current vs Temperature

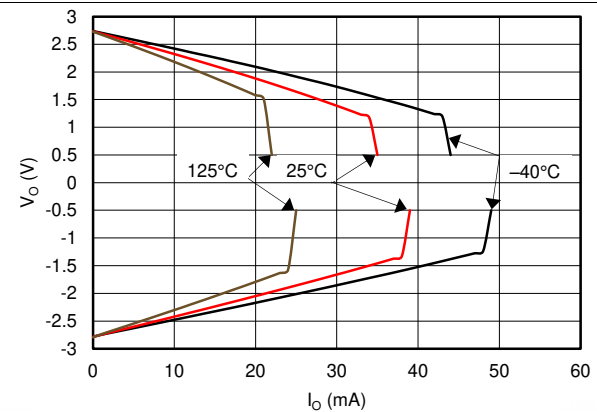

Figure 10. Output Voltage Swing vs Output Current

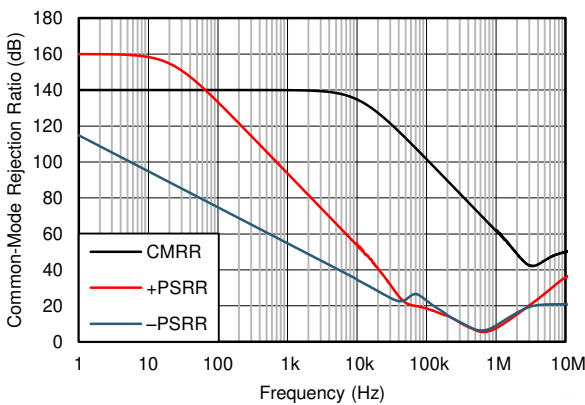

Figure 11. CMRR and PSRR vs Frequency (Referred-to-Input)

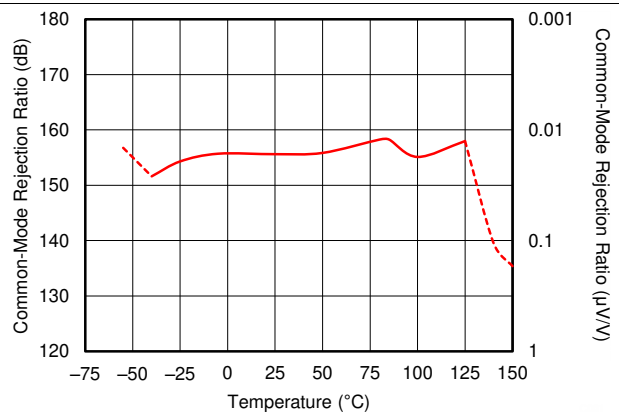
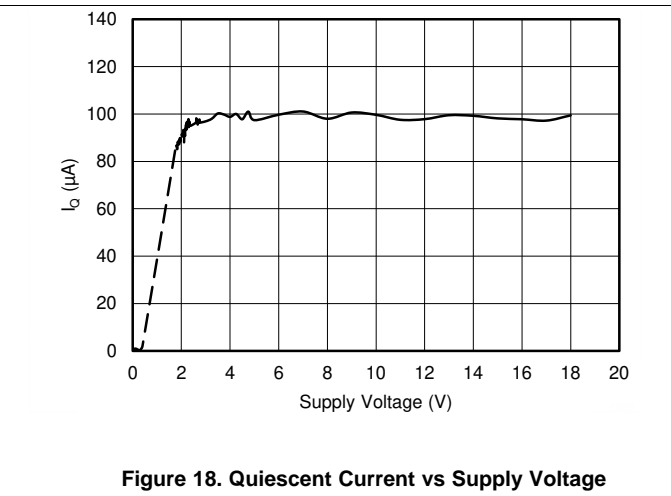
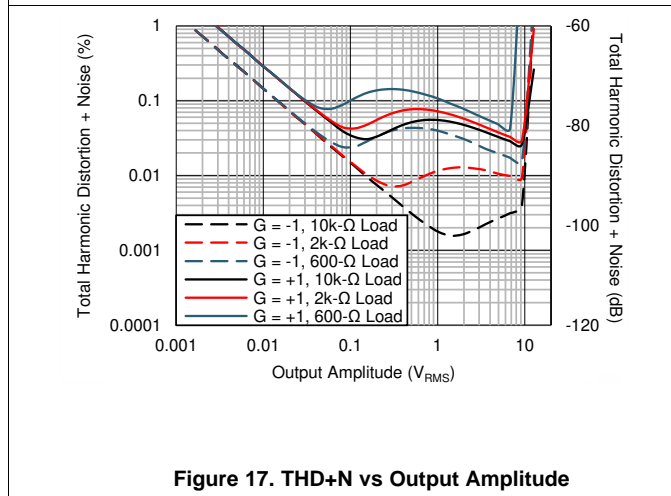
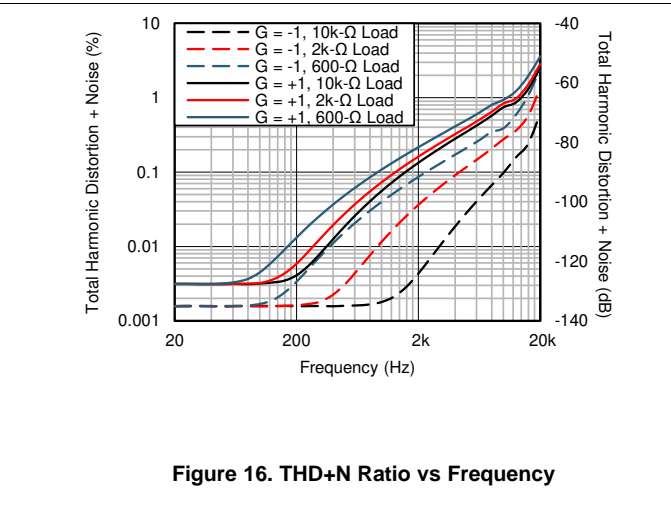
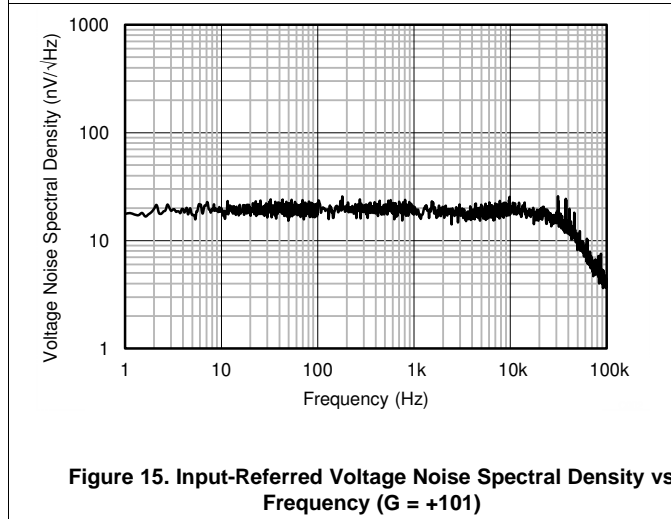
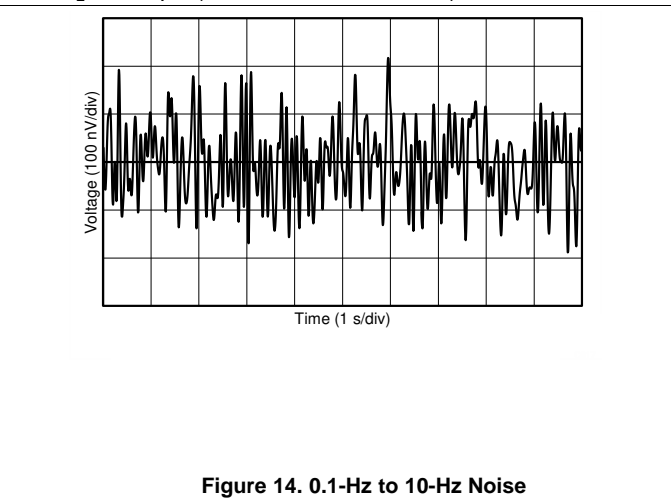
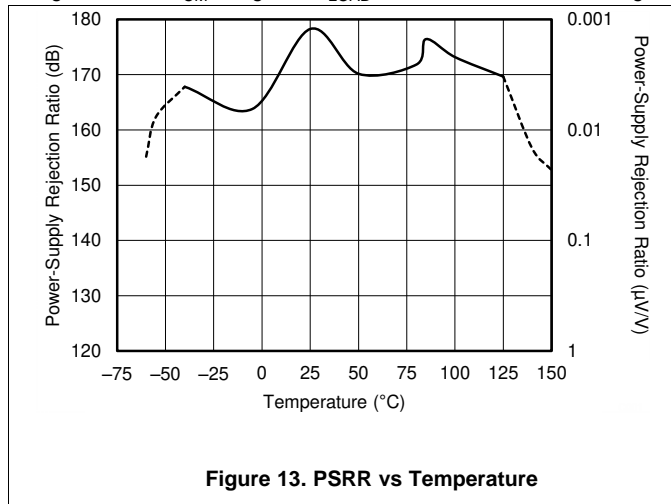

Figure 12. CMRR vs Temperature

at $V_S = \pm 18\text{ V}$, $V_{CM} = V_S / 2$, $R_{LOAD} = 10\text{ k}\Omega$ connected to $V_S / 2$, and $C_L = 100\text{ pF}$ (unless otherwise noted)



at $V_S = \pm 18\text{ V}$, $V_{CM} = V_S / 2$, $R_{LOAD} = 10\text{ k}\Omega$ connected to $V_S / 2$, and $C_L = 100\text{ pF}$ (unless otherwise noted)

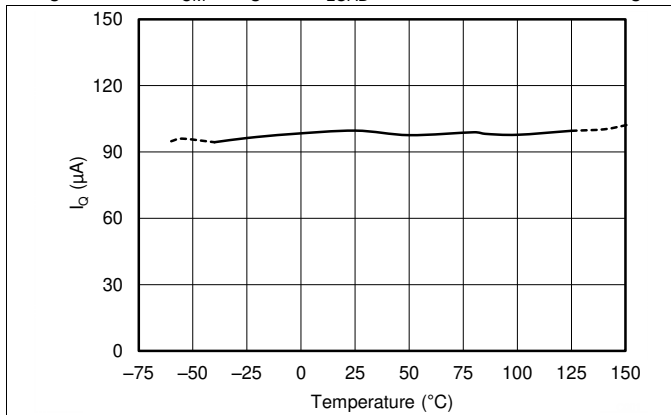

Figure 19. Quiescent Current vs Temperature

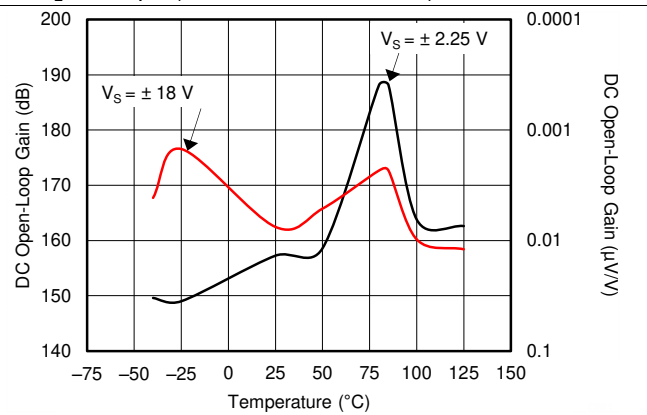

Figure 20. Open-Loop Gain vs Temperature

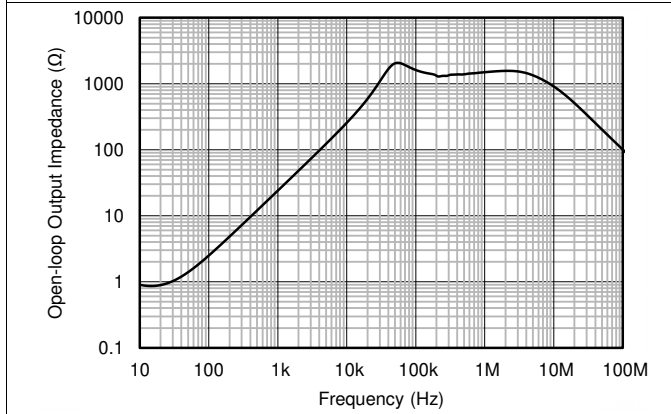

Figure 21. Open-Loop Output Impedance vs Frequency

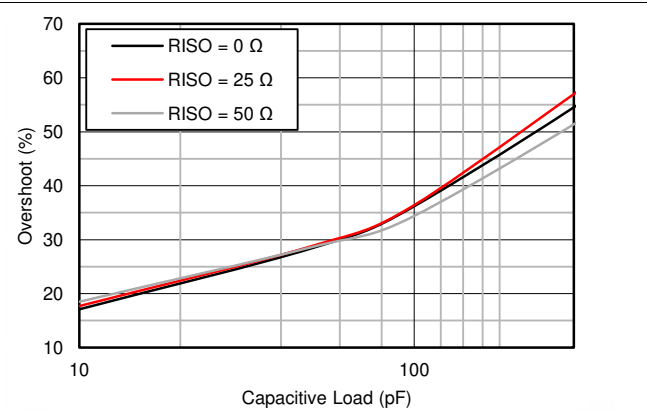

Figure 22. Small-Signal Overshoot vs Capacitive Load ($G = +1$) (10-mV Output Step)

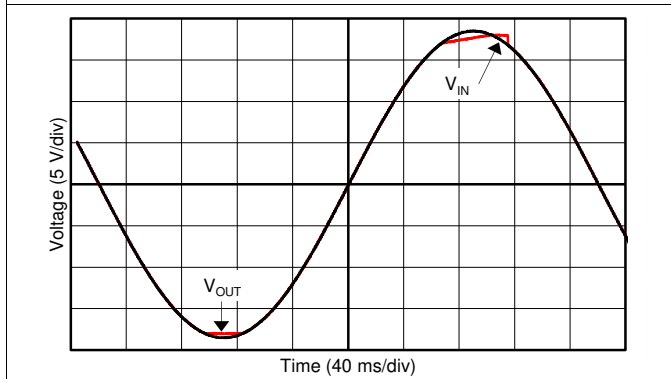

Figure 23. No Phase Reversal

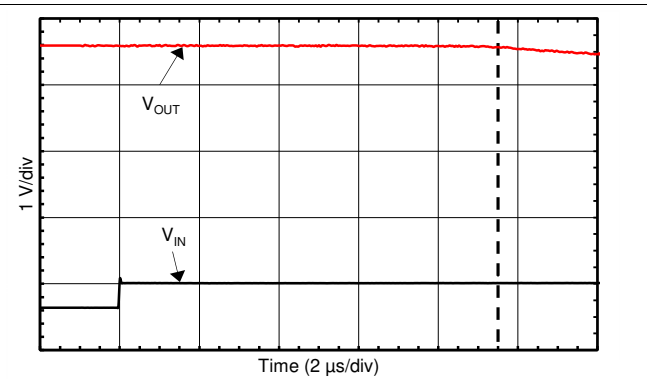
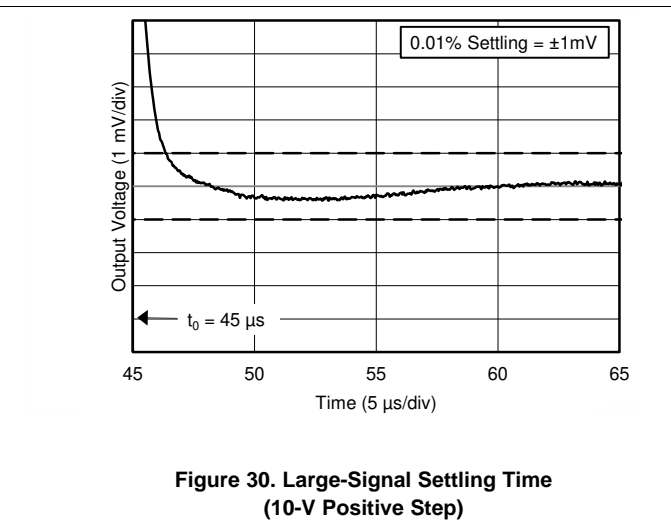
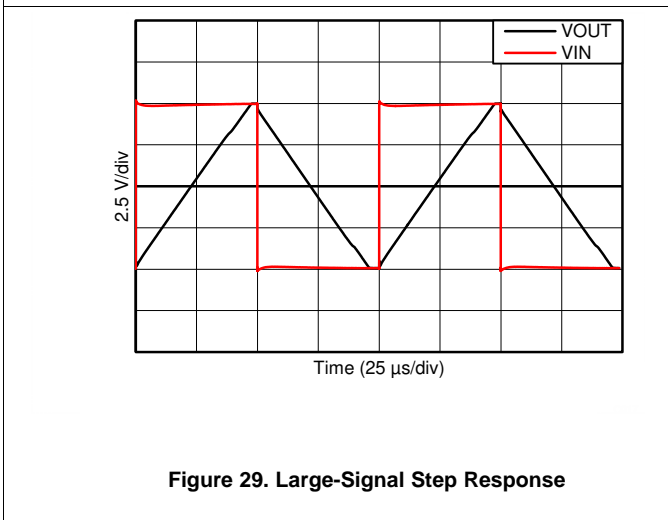
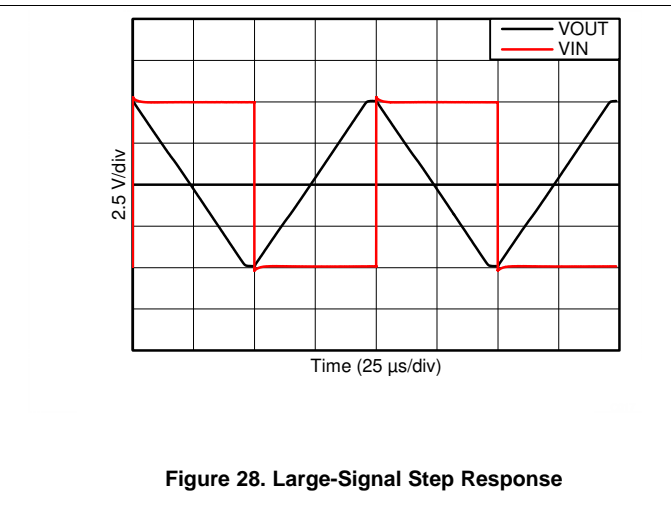
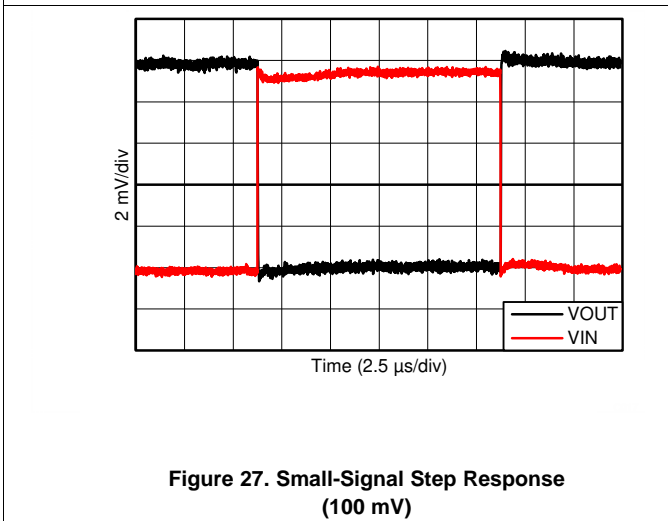
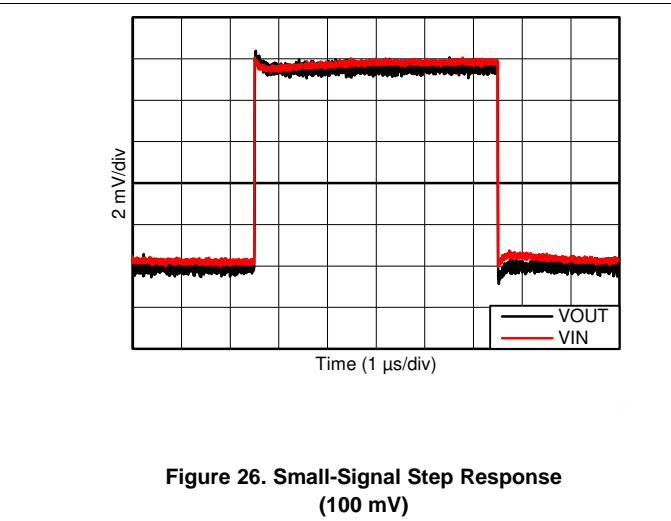
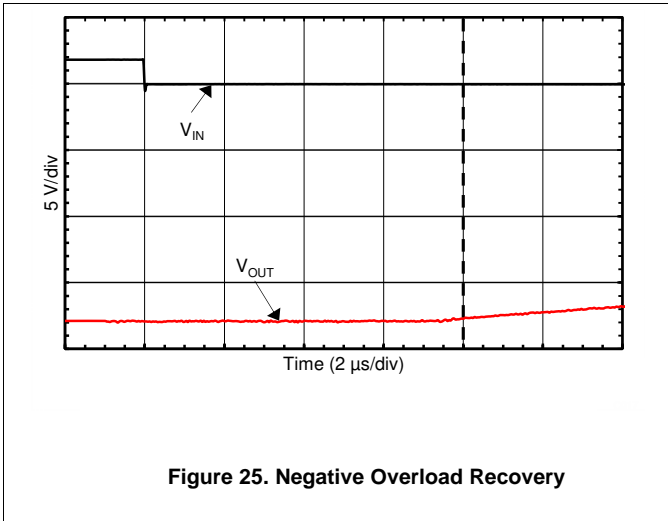

Figure 24. Positive Overload Recovery

at $V_S = \pm 18\text{ V}$, $V_{CM} = V_S / 2$, $R_{LOAD} = 10\text{ k}\Omega$ connected to $V_S / 2$, and $C_L = 100\text{ pF}$ (unless otherwise noted)



at $V_S = \pm 18\text{ V}$, $V_{CM} = V_S / 2$, $R_{LOAD} = 10\text{ k}\Omega$ connected to $V_S / 2$, and $C_L = 100\text{ pF}$ (unless otherwise noted)

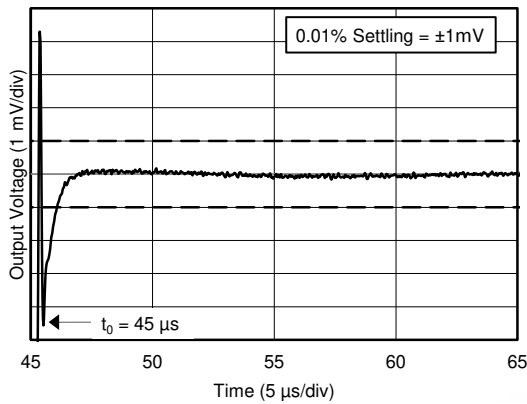

Figure 31. Large-Signal Settling Time (10-V Negative Step)

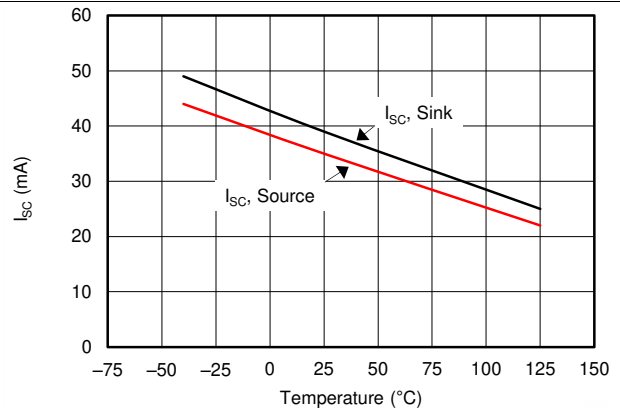

Figure 32. Short-Circuit Current vs Temperature

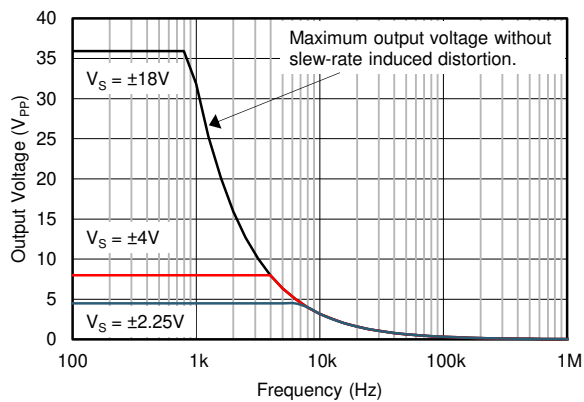

Figure 33. Maximum Output Voltage vs Frequency

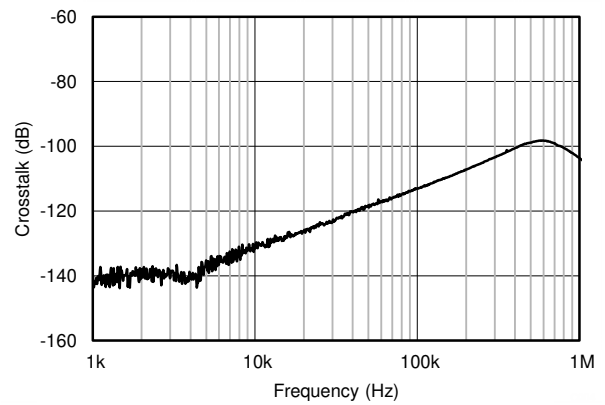

Figure 34. Crosstalk vs Frequency

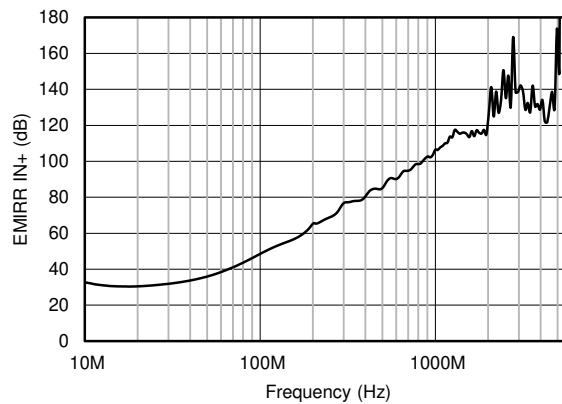

Figure 35. EMIRR IN+ vs Frequency

7 Detailed Description

7.1 Overview

The OPA187, OPA2187, and OPA4187 (OPAx187) operational amplifiers combine precision offset and drift with excellent overall performance, making these devices an excellent choice for many precision applications. The precision offset drift of only $0.001 \mu\text{V}/^\circ\text{C}$ provides stability over the entire temperature range. In addition, these devices offer excellent overall performance with high CMRR, PSRR, and A_{OL} . As with all amplifiers, applications with noisy or high-impedance power supplies require decoupling capacitors close to the device pins. In most cases, $0.1\text{-}\mu\text{F}$ capacitors are adequate.

The OPAx187 is part of a family of zero-drift, low-power, rail-to-rail output operational amplifiers. These devices operate from 4.5 V to 36 V , are unity-gain stable, and are designed for a wide range of general-purpose applications. The zero-drift architecture provides ultra-low input offset voltage, and near-zero input offset voltage drift over temperature and time. This choice of architecture also offers outstanding ac performance, such as ultra-low broadband noise and zero flicker noise.

7.2 Functional Block Diagram

The functional block diagram shows a representation of the proprietary OPAx187 architecture. Functional blocks CHOP1 and CHOP2 operate such that the non-idealities of GM1 are cancelled while the input signal is left in-phase. The integrated notch filter of the OPAx187 family suppresses most of the auto-zero amplifier carrier.

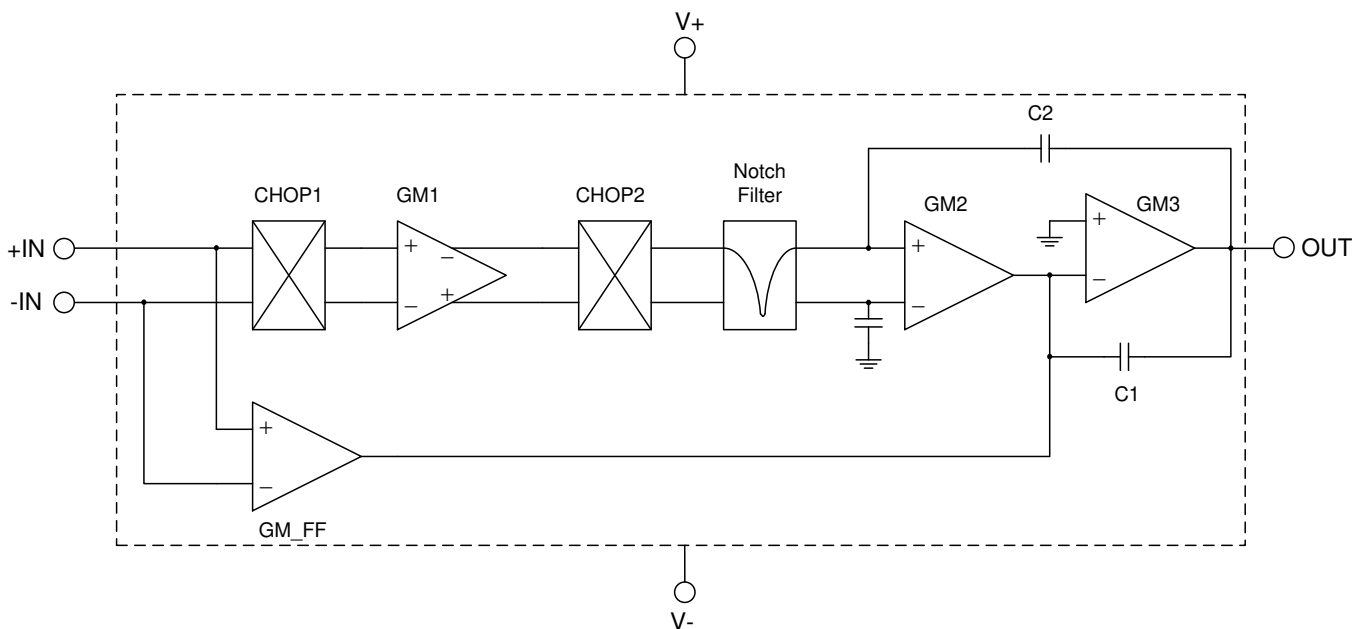

Copyright © 2016, Texas Instruments Incorporated

7.3 Feature Description

The OPAx187 are unity-gain stable and free from unexpected output phase reversal. These devices use a proprietary, periodic autocalibration technique to provide ultra-low input offset voltage and near zero input offset voltage drift over temp and temperature. For lowest offset voltage and precision performance, optimize circuit layout and mechanical conditions. Avoid temperature gradients that create thermoelectric (Seebeck) effects in the thermocouple junctions formed from connecting dissimilar conductors. Cancel these thermally-generated potentials by making sure they are equal on both input pins. Other layout and design considerations include:

Use low thermoelectric-coefficient conditions (avoid dissimilar metals).

Thermally isolate components from power supplies or other heat sources.

Shield operational amplifier and input circuitry from air currents, such as cooling fans.

Follow these guidelines to reduce the likelihood of junctions being at different temperatures, which may cause thermoelectric voltages of 0.1 $\mu\text{V}/^\circ\text{C}$ or higher, depending on the materials used.

7.3.1 Operating Characteristics

The OPAx187 are specified for operation from 4.5 V to 36 V (± 2.25 V to ± 18 V). Many specifications apply from -40°C to $+125^\circ\text{C}$. Parameters that can exhibit significant variance with regard to operating voltage or temperature are presented in the [Typical Characteristics](#) section.

7.3.2 Phase-Reversal Protection

The OPAx187 have an internal phase-reversal protection. Many op amps exhibit a phase reversal when the input is driven beyond its linear common-mode range. This condition is most often encountered in non-inverting circuits when the input is driven beyond the specified common-mode voltage range, causing the output to reverse into the opposite rail. The OPAx187 input prevents phase reversal with excessive common-mode voltage. Instead, the output limits into the appropriate rail. [Figure 36](#) shows this performance.

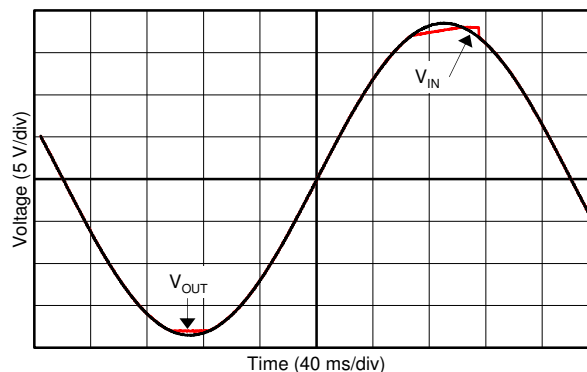

Figure 36. No Phase Reversal

7.3.3 Input Bias Current Clock Feedthrough

Zero-drift amplifiers, such as the OPAx187, use switching on the inputs to correct for the intrinsic offset and drift of the amplifier. Charge injection from the integrated switches on the inputs can introduce very short transients in the input bias current of the amplifier. An extremely short duration prevents these pulses from being amplified; however, the pulses may be coupled to the output of the amplifier through the feedback network. The most effective method to prevent transients in the input bias current from producing additional noise at the amplifier output is to use a low-pass filter such as an RC network.

7.3.4 Internal Offset Correction

The OPAx187 op amps use an auto-calibration technique with a time-continuous 125-kHz op amp in the signal path. This amplifier is zero-corrected every 22 μs using a proprietary technique. At power-up, the amplifier requires approximately 100 μs to achieve the specified V_{OS} accuracy. This design has no aliasing or flicker noise.

Feature Description (continued)

7.3.5 EMI Rejection

The OPAx187 devices use integrated electromagnetic interference (EMI) filtering to reduce the effects of EMI from sources such as wireless communications and densely-populated boards with a mix of analog signal chain and digital components. EMI immunity can be improved with circuit design techniques; the OPAx187 benefit from these design improvements. Texas Instruments has developed the ability to accurately measure and quantify the immunity of an operational amplifier over a broad frequency spectrum extending from 10 MHz to 6 GHz. [Figure 37](#) shows the results of this testing on the OPAx187. [Table 2](#) lists the EMIRR IN+ values for the OPAx187 at particular frequencies commonly encountered in real-world applications. Applications listed in [Table 2](#) may be centered on or operated near the particular frequency shown. Detailed information can also be found in the [EMI Rejection Ratio of Operational Amplifiers application report](#), available for download from www.ti.com.

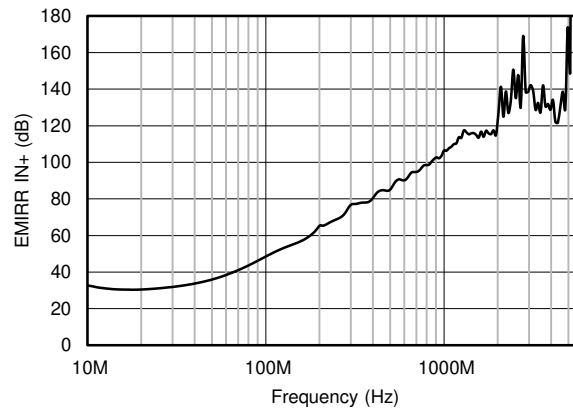

Figure 37. EMIRR Testing

Table 2. OPAx187 EMIRR IN+ for Frequencies of Interest

FREQUENCY	APPLICATION OR ALLOCATION	EMIRR IN+
400 MHz	Mobile radio, mobile satellite, space operation, weather, radar, ultra-high frequency (UHF) applications	81.8 dB
900 MHz	Global system for mobile communications (GSM) applications, radio communication, navigation, GPS (to 1.6 GHz), GSM, aeronautical mobile, UHF applications	102.7 dB
1.8 GHz	GSM applications, mobile personal communications, broadband, satellite, L-band (1 GHz to 2 GHz)	115.4 dB
2.4 GHz	802.11b, 802.11g, 802.11n, Bluetooth®, mobile personal communications, industrial, scientific and medical (ISM) radio band, amateur radio and satellite, S-band (2 GHz to 4 GHz)	150.7 dB
3.6 GHz	Radiolocation, aero communication and navigation, satellite, mobile, S-band	142.0 dB
5 GHz	802.11a, 802.11n, aero communication and navigation, mobile communication, space and satellite operation, C-band (4 GHz to 8 GHz)	173.8 dB

7.3.6 Capacitive Load and Stability

The dynamic characteristics of the OPAx187 are optimized for a range of common operating conditions. The combination of low closed-loop gain and high capacitive loads decreases the amplifier phase margin and can lead to gain peaking or oscillations. As a result, larger capacitive loads must be isolated from the output. The simplest way to achieve this isolation is to add a small resistor (for example, R_{OUT} equal to 50 Ω) in series with the output. [Figure 38](#) illustrates small-signal overshoot versus capacitive load for several values of R_{OUT} . Also, for details of analysis techniques and application circuits, refer to the [Feedback Plots Define Op Amp AC Performance application report](#), available for download from www.ti.com.

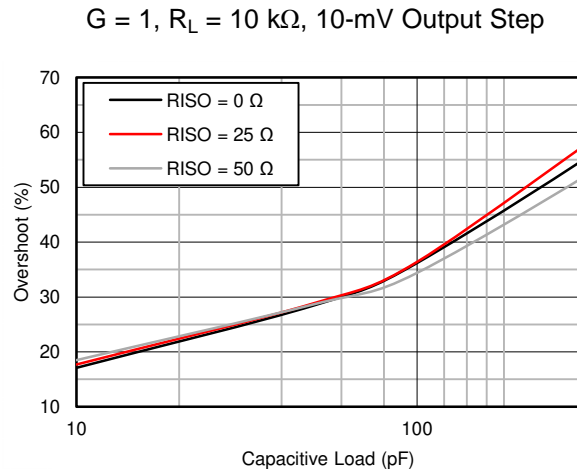

Figure 38. Small-Signal Overshoot vs Capacitive Load

7.3.7 Electrical Overstress

Designers often ask questions about the capability of an operational amplifier to withstand electrical overstress. These questions tend to focus on the device inputs, but may involve the supply voltage pins or even the output pin. Each of these different pin functions have electrical stress limits determined by the voltage breakdown characteristics of the particular semiconductor fabrication process and specific circuits connected to the pin. Additionally, internal electrostatic discharge (ESD) protection is built into these circuits to protect them from accidental ESD events both before and during product assembly.

A good understanding of this basic ESD circuitry and its relevance to an electrical overstress event is helpful. See [Figure 39](#) for an illustration of the ESD circuits contained in the OPAx187 (indicated by the dashed-line area). The ESD protection circuitry involves several current-steering diodes connected from the input and output pins and routed back to the internal power-supply lines, where the diodes meet at an absorption device internal to the op amp. This protection circuitry is intended to remain inactive during normal circuit operation.

An ESD event produces a short-duration, high-voltage pulse that is transformed into a short-duration, high-current pulse while discharging through a semiconductor device. The ESD protection circuits are designed to provide a current path around the op amp core to prevent damage. The energy absorbed by the protection circuitry is then dissipated as heat.

When an ESD voltage develops across two or more amplifier device pins, current flows through one or more steering diodes. Depending on the path that the current takes, the absorption device may activate. The absorption device has a trigger, or threshold voltage, that is greater than the normal operating voltage of the OPAx187, but less than the device breakdown voltage level. When this threshold is exceeded, the absorption device quickly activates and clamps the voltage across the supply rails to a safe level.

When the operational amplifier connects into a circuit (see [Figure 39](#)), the ESD protection components are intended to remain inactive and do not become involved in the application circuit operation. However, circumstances may arise where an applied voltage exceeds the operating voltage range of a given pin. If this condition occurs, there is a risk that some internal ESD protection circuits may be biased on, and conduct current. Any such current flow occurs through steering-diode paths, and rarely involves the absorption device.

[Figure 39](#) shows a specific example where the input voltage (V_{IN}) exceeds the positive supply voltage ($+V_S$) by 500 mV or more. Much of what happens in the circuit depends on the supply characteristics. If $+V_S$ can sink the current, one of the upper input steering diodes conducts and directs current to $+V_S$. Excessively high current levels can flow with increasingly higher V_{IN} . As a result, the data-sheet specifications recommend that applications limit the input current to 10 mA.

If the supply is not capable of sinking the current, V_{IN} may begin sourcing current to the operational amplifier, and then take over as the source of positive supply voltage. The danger in this case is that the voltage can rise to levels that exceed the operational amplifier absolute maximum ratings.

Another common question involves what happens to the amplifier if an input signal is applied to the input while power supply $+V_S$ or $-V_S$ is at 0 V. Again, this question depends on the supply characteristic while at 0 V, or at a level less than the input signal amplitude. If the supplies are high impedance, then the operational amplifier supply current may be supplied by the input source through the current-steering diodes. This state is not a normal bias condition; the amplifier most likely will not operate normally. If the supplies are low impedance, then the current through the steering diodes can become quite high. The current level depends on the ability of the input source to deliver current, and any resistance in the input path.

If there is any uncertainty about the ability of the supply to absorb this current, add external transient voltage suppressor (TVS) diodes to the supply pins, as shown in Figure 39. Select the TVS voltage so that the diode does not turn on during normal operation. However, make sure that the TVS voltage is low enough so that the TVS diode conducts if the supply pin exceeds the safe operating supply voltage level.

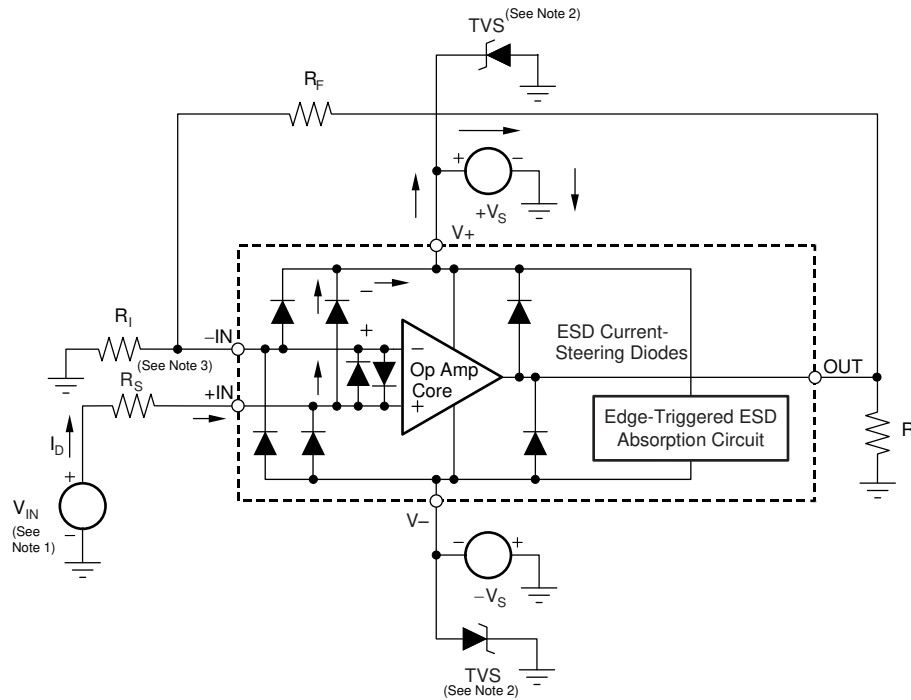

Copyright © 2016, Texas Instruments Incorporated

NOTE 1: $V_{IN} = +V_S + 500 \text{ mV}$.

NOTE 2: TVS: $+V_{S(max)} > V_{TVSBR} (min) > +V_S$.

NOTE 3: Suggested value is approximately 1 k Ω .

Figure 39. Equivalent Internal ESD Circuitry Relative to a Typical Circuit Application

The OPAx187 input pins are protected from excessive differential voltage with back-to-back diodes, as shown in Figure 39. In most circuit applications, the input protection circuitry has no consequence. However, in low-gain or $G = 1$ circuits, fast-ramping input signals can forward-bias these diodes because the output of the amplifier cannot respond rapidly enough to the input ramp. If the input signal is fast enough to create this forward-bias condition, the input signal current must be limited to 10 mA or less. If the input signal is not inherently limited, an input series resistor can be used to limit the signal input current. This input series resistor degrades the low-noise performance of the OPAx187. Figure 39 shows an example configuration that implements a current-limiting feedback resistor.

7.4 Device Functional Modes

The OPAx187 have a single functional mode and are operational when the power-supply voltage is greater than 4.5 V (± 0.25 V). The maximum power supply voltage for the OPAx187 is 36 V (± 18 V).

8 Application and Implementation

NOTE

Information in the following applications sections is not part of the TI component specification, and TI does not warrant its accuracy or completeness. TI's customers are responsible for determining suitability of components for their purposes. Customers should validate and test their design implementation to confirm system functionality.

8.1 Application Information

The OPAx187 operational amplifier family combines precision offset and drift with excellent overall performance, making this device an excellent choice for many precision applications. The precision offset drift of only $0.001 \mu\text{V}/^\circ\text{C}$ provides stability over the entire temperature range. In addition, the device pairs excellent CMRR, PSRR, and A_{OL} dc performance with outstanding low-noise operation. As with all amplifiers, applications with noisy or high-impedance power supplies require decoupling capacitors close to the device pins. In most cases, $0.1\text{-}\mu\text{F}$ capacitors are adequate.

The following application examples highlight only a few of the circuits where the OPAx187 can be used.

8.2 Typical Applications

8.2.1 High-Side Voltage-to-Current (V-I) Converter

The circuit shown in [Figure 40](#) is a high-side voltage-to-current (V-I) converter. The converter translates an input voltage of 0 V to 2 V into an output current of 0 mA to 100 mA. [Figure 41](#) shows the measured transfer function for this circuit. The low offset voltage and offset drift of the OPA2187 facilitate excellent dc accuracy for the circuit.

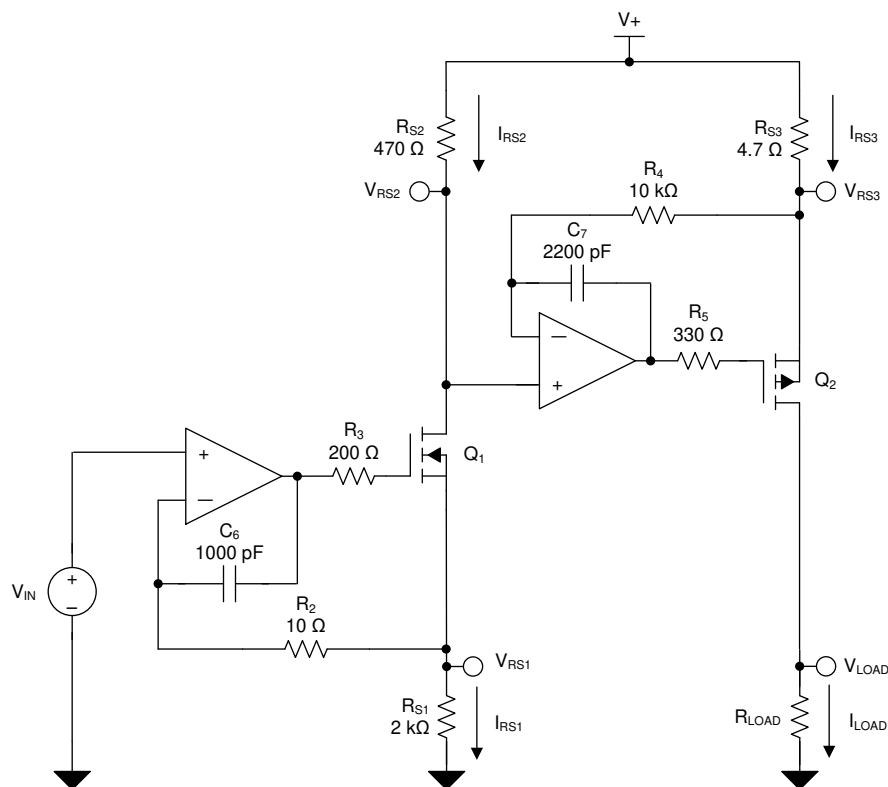

Copyright © 2016, Texas Instruments Incorporated

Figure 40. High-Side Voltage-to-Current (V-I) Converter

Typical Applications (continued)

8.2.1.1 Design Requirements

The design requirements are:

- Supply voltage: 5 V DC
- Input: 0 V to 2 V DC
- Output: 0 mA to 100 mA DC

8.2.1.2 Detailed Design Procedure

The V-I transfer function of the circuit is based on the relationship between the input voltage, V_{IN} , and the three current sensing resistors, R_{S1} , R_{S2} , and R_{S3} . The relationship between V_{IN} and R_{S1} determines the current that flows through the first stage of the design. The current gain from the first stage to the second stage is based on the relationship between R_{S2} and R_{S3} .

This application benefits from an operational amplifier with low offset voltage, low temperature drift, and rail-to-rail output. The OPAx187 CMOS operational amplifiers are high-precision, ultra-low offset, ultra-low drift amplifier, optimized for wide-voltage, single-supply operation, with an output swing to within 5 mV of the positive rail. The OPAx187 family uses chopping techniques to provide low initial offset voltage and near-zero drift over time and temperature. Low offset voltage and low drift reduce the offset error in the system, making this device appropriate for precise dc control. The rail-to-rail output stage of the OPAx187 makes sure that the output swing of the operational amplifier is able to fully control the gate of the MOSFET devices within the supply rails.

A detailed error analysis, design procedure, and additional measured results are given in reference design TIPD102, a step-by-step process to design a [High-Side Voltage-to-Current \(V-I\) Converter](#).

For step-by-step design procedure, circuit schematics, bill of materials, PCB files, simulation results, and test results, refer to [TI Precision Design TIPD102, High-Side Voltage-to-Current \(V-I\) Converter](#).

8.2.1.3 Application Curve

Figure 41 shows the measured transfer function for the high-side voltage-to-current converter shown in Figure 40.

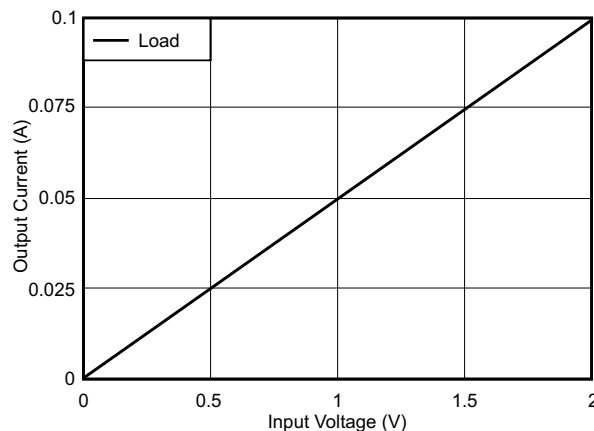

Figure 41. Measured Transfer Function for High-Side V-I Converter

8.2.2 Discrete INA + Attenuation for ADC With 3.3-V Supply

NOTE

The TINA-TI files shown in the following sections require that either the TINA software (from DesignSoft™) or TINA-TI software be installed. Download the free TINA-TI software from the [TINA-TI web folder](#).

Figure 42 shows an example of how the OPA187 is used as a high-voltage, high-impedance front-end for a precision, discrete instrumentation amplifier with attenuation. The INA159 provides the attenuation that allows this circuit to easily interface with 3.3-V or 5-V analog-to-digital converters (ADCs). Click the following link to download the TINA-TI file: [Discrete INA](#).

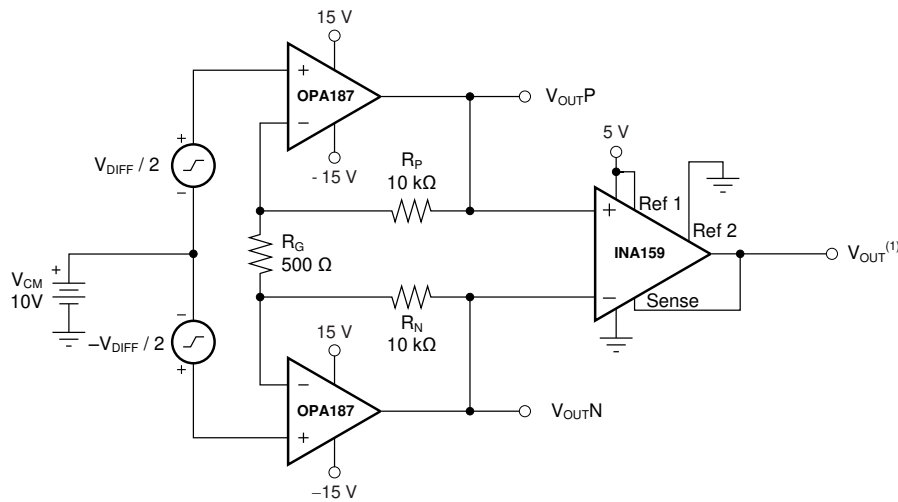

Copyright © 2016, Texas Instruments Incorporated

$$(1) V_{OUT} = V_{DIFF} \times (41 / 5) + (Ref 1) / 2.$$

Figure 42. Discrete INA + Attenuation for ADC With a 3.3-V Supply

8.2.3 Bridge Amplifier

Figure 43 shows the basic configuration for a bridge amplifier. Click the following link to download the TINA-TI file: [Bridge Amplifier Circuit](#).

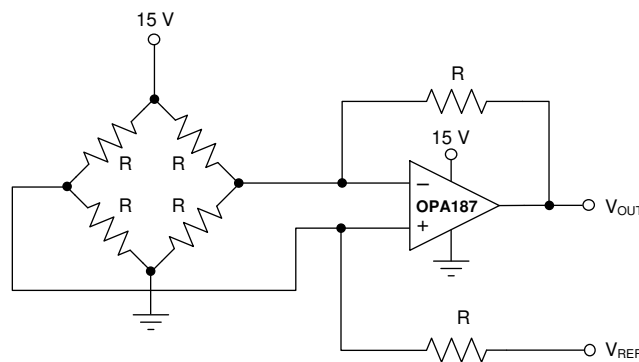

Copyright © 2016, Texas Instruments Incorporated

Figure 43. Bridge Amplifier

8.2.4 Low-Side Current Monitor

Figure 44 shows the OPA187 configured in a low-side, current-sensing application. The load current (I_{LOAD}) creates a voltage drop across the shunt resistor (R_{SHUNT}). This voltage is amplified by the OPA187, with a gain of 201. The load current is set from 0 A to 500 mA, and corresponds to an output voltage range from 0 V to 10 V. The output range can be adjusted by changing the shunt resistor or gain of the configuration. Click the following link to download the TINA-TI file: [Current-Sensing Circuit](#).

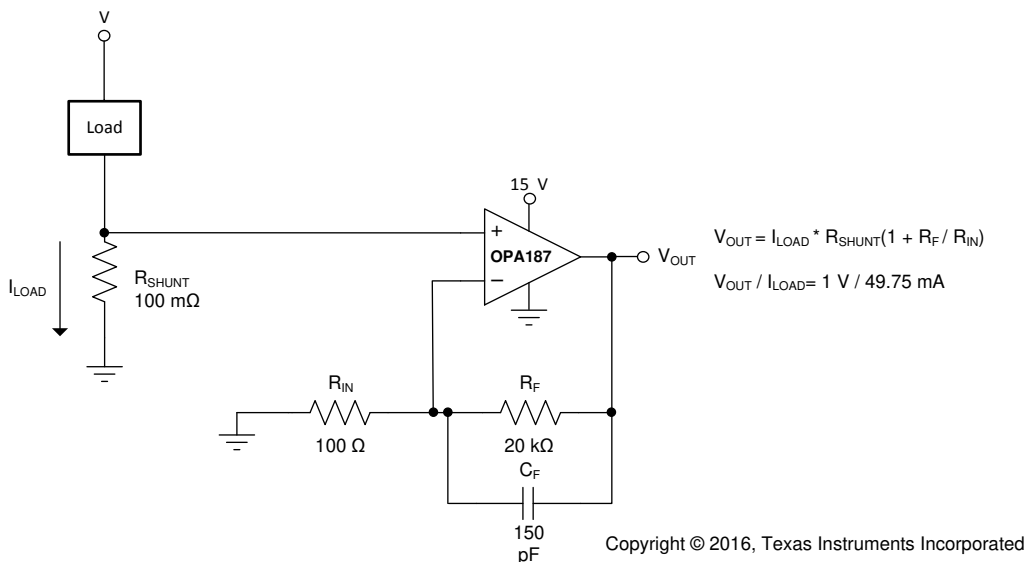

Figure 44. Low-Side Current Monitor

8.2.5 Programmable Power Supply

Figure 45 shows the OPA187 configured as a precision, programmable power supply using the 16-bit, voltage output DAC8581 and the OPA548 high-current amplifier. This application amplifies the digital-to-analog converter (DAC) voltage by a value of five, and handles a large variety of capacitive and current loads. The OPA187 in the front-end provides precision and low drift across a wide range of inputs and conditions. Click the following link to download the TINA-TI file: [Programmable Power-Supply Circuit](#).

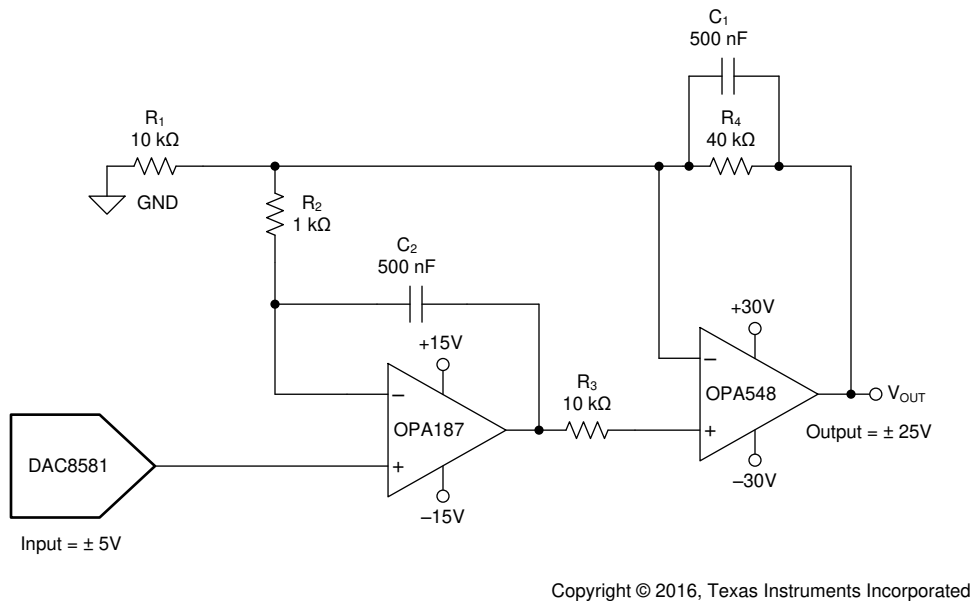
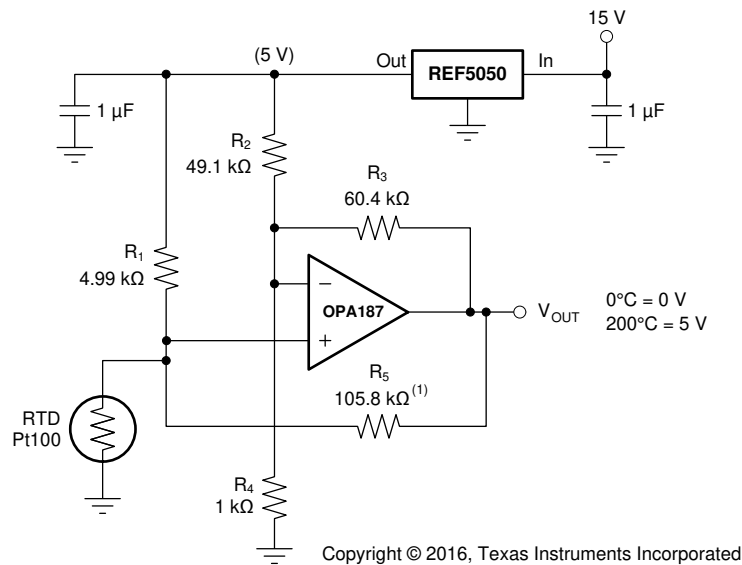

Figure 45. Programmable Power Supply

8.2.6 RTD Amplifier With Linearization

See the [Analog Linearization Of Resistance Temperature Detectors](#) technical brief, for an in-depth analysis of Figure 46. Click the following link to download the TINA-TI file: [RTD Amplifier With Linearization](#).



(1) R_5 provides positive-varying excitation to linearize output.

Figure 46. RTD Amplifier With Linearization

9 Power Supply Recommendations

The OPAx187 is specified for operation from 4.5 V to 36 V (± 2.25 V to ± 18 V); many specifications apply from -40°C to $+125^\circ\text{C}$. The [Typical Characteristics](#) presents parameters that can exhibit significant variance with regard to operating voltage or temperature.

CAUTION

Supply voltages larger than 40 V can permanently damage the device (see the [Absolute Maximum Ratings](#)).

Place 0.1- μF bypass capacitors close to the power-supply pins to reduce errors coupling in from noisy or high-impedance power supplies. For more detailed information on bypass capacitor placement, see the [Layout](#) section.

10 Layout

10.1 Layout Guidelines

For best operational performance of the device, use good printed circuit board (PCB) layout practices, including:

- Low-ESR, 0.1- μF ceramic bypass capacitors must be connected between each supply pin and ground; place the capacitors as close to the device as possible. A single bypass capacitor from V+ to ground is applicable to single-supply applications.
- To reduce parasitic coupling, run the input traces as far away from the supply lines as possible.
- A ground plane helps distribute heat and reduces EMI noise pickup.
- Place the external components as close to the device as possible. This configuration prevents parasitic errors (such as the Seebeck effect) from occurring.
- Consider a driven, low-impedance guard ring around the critical traces. A guard ring can significantly reduce leakage currents from nearby traces that are at different potentials.

10.2 Layout Example

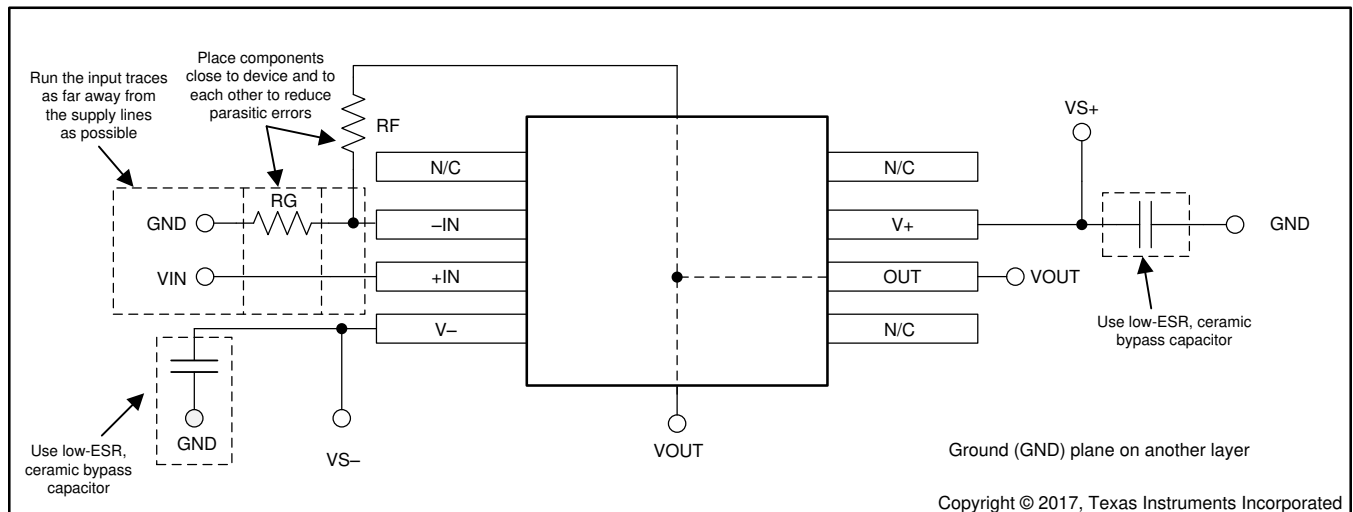
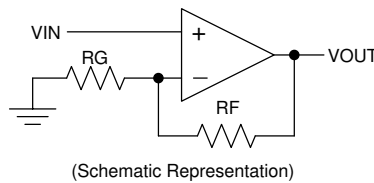

Figure 47. Layout Example

11 Device and Documentation Support

11.1 Device Support

11.1.1 Development Support

11.1.1.1 TINA-TI™ (Free Software Download)

TINA™ is a simple, powerful, and easy-to-use circuit simulation program based on a SPICE engine. TINA-TI™ is a free, fully-functional version of the TINA software, preloaded with a library of macro models, in addition to a range of both passive and active models. TINA-TI provides all the conventional DC, transient, and frequency domain analysis of SPICE, as well as additional design capabilities.

Available as a [free download](#) from the Analog eLab Design Center, TINA-TI offers extensive post-processing capability that lets users format results various ways. Virtual instruments offer users the ability to select input waveforms and probe circuit nodes, voltages, and waveforms, creating a dynamic quick-start tool.

NOTE

These files require that either the TINA software (from DesignSoft™) or TINA-TI software be installed. Download the free TINA-TI software from the [TINA-TI folder](#).

11.1.1.2 TI Precision Designs

TI Precision Designs are analog solutions created by TI's precision analog applications experts which offer the theory of operation, component selection, simulation, complete PCB schematic and layout, bill of materials, and measured performance of many useful circuits. TI Precision Designs are available online at <http://www.ti.com/ww/en/analog/precision-designs/>.

11.1.1.3 WEBENCH® Filter Designer

WEBENCH® Filter Designer is a simple, powerful, and easy-to-use active filter design program. The WEBENCH Filter Designer lets users create optimized filter designs using a selection of TI operational amplifiers and passive components from TI's vendor partners.

Available as a web-based tool from the WEBENCH Design Center, [WEBENCH® Filter Designer](#) lets users design, optimize, and simulate complete multistage active filter solutions within minutes.

11.2 Documentation Support

11.2.1 Related Documentation

For related documentation, see the following:

- Texas Instruments, [Operational Amplifier Gain Stability, Part 3: AC Gain-Error Analysis](#) technical brief
- Texas Instruments, [Operational Amplifier Gain Stability, Part 2: DC Gain-Error Analysis](#) technical brief
- Texas Instruments, [Using Infinite-Gain, MFB Filter Topology In Fully Differential Active Filters](#) technical brief
- Texas Instruments, [Op Amp Performance Analysis](#) application bulletin
- Texas Instruments, [Single-Supply Operation of Operational Amplifiers](#) application bulletin
- Texas Instruments, [Tuning in Amplifiers](#) application bulletin
- Texas Instruments, [Shelf-Life Evaluation of Lead-Free Component Finishes](#) application report

11.3 Related Links

Table 3 lists quick access links. Categories include technical documents, support and community resources, tools and software, and quick access to sample or buy.

Table 3. Related Links

PARTS	PRODUCT FOLDER	SAMPLE AND BUY	TECHNICAL DOCUMENTS	TOOLS AND SOFTWARE	SUPPORT AND COMMUNITY
OPA187	Click here	Click here	Click here	Click here	Click here
OPA2187	Click here	Click here	Click here	Click here	Click here
OPA4187	Click here	Click here	Click here	Click here	Click here

11.4 Receiving Notification of Documentation Updates

To receive notification of documentation updates, navigate to the device product folder on ti.com. In the upper right corner, click on the *Alert me* button to register and receive a weekly digest of any product information that has changed. For change details, review the revision history included in any revised document

11.5 Support Resources

TI E2E™ [support forums](#) are an engineer's go-to source for fast, verified answers and design help — straight from the experts. Search existing answers or ask your own question to get the quick design help you need.

Linked content is provided "AS IS" by the respective contributors. They do not constitute TI specifications and do not necessarily reflect TI's views; see TI's [Terms of Use](#).

11.6 Trademarks

TINA-TI, E2E are trademarks of Texas Instruments.
 WEBENCH is a registered trademark of Texas Instruments.
 Bluetooth is a registered trademark of Bluetooth SIG, Inc.
 DesignSoft, TINA are trademarks of DesignSoft, Inc.
 All other trademarks are the property of their respective owners.

11.7 Electrostatic Discharge Caution



This integrated circuit can be damaged by ESD. Texas Instruments recommends that all integrated circuits be handled with appropriate precautions. Failure to observe proper handling and installation procedures can cause damage.

ESD damage can range from subtle performance degradation to complete device failure. Precision integrated circuits may be more susceptible to damage because very small parametric changes could cause the device not to meet its published specifications.

11.8 Glossary

[SLYZ022](#) — *TI Glossary*.

This glossary lists and explains terms, acronyms, and definitions.

12 Mechanical, Packaging, and Orderable Information

The following pages include mechanical, packaging, and orderable information. This information is the most current data available for the designated devices. This data is subject to change without notice and revision of this document. For browser-based versions of this data sheet, refer to the left-hand navigation.

PACKAGING INFORMATION

Orderable part number	Status (1)	Material type (2)	Package Pins	Package qty Carrier	RoHS (3)	Lead finish/ Ball material (4)	MSL rating/ Peak reflow (5)	Op temp (°C)	Part marking (6)
OPA187ID	Active	Production	SOIC (D) 8	75 TUBE	Yes	NIPDAU	Level-2-260C-1 YEAR	-40 to 125	OPA187
OPA187ID.B	Active	Production	SOIC (D) 8	75 TUBE	Yes	NIPDAU	Level-2-260C-1 YEAR	-40 to 125	OPA187
OPA187IDBVR	Active	Production	SOT-23 (DBV) 5	3000 LARGE T&R	Yes	NIPDAU	Level-2-260C-1 YEAR	-40 to 125	1CUV
OPA187IDBVR.B	Active	Production	SOT-23 (DBV) 5	3000 LARGE T&R	Yes	NIPDAU	Level-2-260C-1 YEAR	-40 to 125	1CUV
OPA187IDBVT	Active	Production	SOT-23 (DBV) 5	250 SMALL T&R	Yes	NIPDAU	Level-2-260C-1 YEAR	-40 to 125	1CUV
OPA187IDBVT.B	Active	Production	SOT-23 (DBV) 5	250 SMALL T&R	Yes	NIPDAU	Level-2-260C-1 YEAR	-40 to 125	1CUV
OPA187IDBVTG4	Active	Production	SOT-23 (DBV) 5	250 SMALL T&R	Yes	NIPDAU	Level-2-260C-1 YEAR	-40 to 125	1CUV
OPA187IDBVTG4.B	Active	Production	SOT-23 (DBV) 5	250 SMALL T&R	Yes	NIPDAU	Level-2-260C-1 YEAR	-40 to 125	1CUV
OPA187IDG4	Active	Production	SOIC (D) 8	75 TUBE	Yes	NIPDAU	Level-2-260C-1 YEAR	-40 to 125	OPA187
OPA187IDG4.B	Active	Production	SOIC (D) 8	75 TUBE	Yes	NIPDAU	Level-2-260C-1 YEAR	-40 to 125	OPA187
OPA187IDGKR	Active	Production	VSSOP (DGK) 8	2500 LARGE T&R	Yes	NIPDAUAG SN	Level-2-260C-1 YEAR	-40 to 125	1D96
OPA187IDGKR.B	Active	Production	VSSOP (DGK) 8	2500 LARGE T&R	Yes	SN	Level-2-260C-1 YEAR	-40 to 125	1D96
OPA187IDGKT	Active	Production	VSSOP (DGK) 8	250 SMALL T&R	Yes	NIPDAUAG SN	Level-2-260C-1 YEAR	-40 to 125	1D96
OPA187IDGKT.B	Active	Production	VSSOP (DGK) 8	250 SMALL T&R	Yes	SN	Level-2-260C-1 YEAR	-40 to 125	1D96
OPA187IDR	Active	Production	SOIC (D) 8	2500 LARGE T&R	Yes	NIPDAU	Level-2-260C-1 YEAR	-40 to 125	OPA187
OPA187IDR.B	Active	Production	SOIC (D) 8	2500 LARGE T&R	Yes	NIPDAU	Level-2-260C-1 YEAR	-40 to 125	OPA187
OPA2187ID	Active	Production	SOIC (D) 8	75 TUBE	Yes	NIPDAU	Level-2-260C-1 YEAR	-40 to 125	OP2187
OPA2187ID.B	Active	Production	SOIC (D) 8	75 TUBE	Yes	NIPDAU	Level-2-260C-1 YEAR	-40 to 125	OP2187
OPA2187IDGKR	Active	Production	VSSOP (DGK) 8	2500 LARGE T&R	Yes	Call TI Nipdau	Level-2-260C-1 YEAR	-40 to 125	16TV
OPA2187IDGKR.B	Active	Production	VSSOP (DGK) 8	2500 LARGE T&R	Yes	Call TI	Level-2-260C-1 YEAR	-40 to 125	16TV
OPA2187IDGKRG4	Active	Production	VSSOP (DGK) 8	2500 LARGE T&R	Yes	NIPDAU	Level-2-260C-1 YEAR	-40 to 125	16TV
OPA2187IDGKRG4.B	Active	Production	VSSOP (DGK) 8	2500 LARGE T&R	Yes	NIPDAU	Level-2-260C-1 YEAR	-40 to 125	16TV
OPA2187IDGKT	Active	Production	VSSOP (DGK) 8	250 SMALL T&R	Yes	Call TI Nipdau	Level-2-260C-1 YEAR	-40 to 125	16TV
OPA2187IDGKT.B	Active	Production	VSSOP (DGK) 8	250 SMALL T&R	Yes	Call TI	Level-2-260C-1 YEAR	-40 to 125	16TV
OPA2187IDR	Active	Production	SOIC (D) 8	2500 LARGE T&R	Yes	NIPDAU	Level-2-260C-1 YEAR	-40 to 125	OP2187
OPA2187IDR.B	Active	Production	SOIC (D) 8	2500 LARGE T&R	Yes	NIPDAU	Level-2-260C-1 YEAR	-40 to 125	OP2187
OPA2187IDRG4	Active	Production	SOIC (D) 8	2500 LARGE T&R	Yes	NIPDAU	Level-2-260C-1 YEAR	-40 to 125	OP2187
OPA2187IDRG4.B	Active	Production	SOIC (D) 8	2500 LARGE T&R	Yes	NIPDAU	Level-2-260C-1 YEAR	-40 to 125	OP2187
OPA4187ID	Active	Production	SOIC (D) 14	50 TUBE	Yes	NIPDAU	Level-2-260C-1 YEAR	-40 to 125	OPA4187

Orderable part number	Status (1)	Material type (2)	Package Pins	Package qty Carrier	RoHS (3)	Lead finish/ Ball material (4)	MSL rating/ Peak reflow (5)	Op temp (°C)	Part marking (6)
OPA4187ID.B	Active	Production	SOIC (D) 14	50 TUBE	Yes	NIPDAU	Level-2-260C-1 YEAR	-40 to 125	OPA4187
OPA4187IDG4	Active	Production	SOIC (D) 14	50 TUBE	Yes	NIPDAU	Level-2-260C-1 YEAR	-40 to 125	OPA4187
OPA4187IDG4.B	Active	Production	SOIC (D) 14	50 TUBE	Yes	NIPDAU	Level-2-260C-1 YEAR	-40 to 125	OPA4187
OPA4187IDR	Active	Production	SOIC (D) 14	2500 LARGE T&R	Yes	NIPDAU	Level-2-260C-1 YEAR	-40 to 125	OPA4187
OPA4187IDR.B	Active	Production	SOIC (D) 14	2500 LARGE T&R	Yes	NIPDAU	Level-2-260C-1 YEAR	-40 to 125	OPA4187
OPA4187IPW	Active	Production	TSSOP (PW) 14	90 TUBE	Yes	NIPDAU	Level-2-260C-1 YEAR	-40 to 125	OPA4187
OPA4187IPW.B	Active	Production	TSSOP (PW) 14	90 TUBE	Yes	NIPDAU	Level-2-260C-1 YEAR	-40 to 125	OPA4187
OPA4187IPWR	Active	Production	TSSOP (PW) 14	2000 LARGE T&R	Yes	NIPDAU	Level-2-260C-1 YEAR	-40 to 125	OPA4187
OPA4187IPWR.B	Active	Production	TSSOP (PW) 14	2000 LARGE T&R	Yes	NIPDAU	Level-2-260C-1 YEAR	-40 to 125	OPA4187
OPA4187IPWRG4	Active	Production	TSSOP (PW) 14	2000 LARGE T&R	Yes	NIPDAU	Level-2-260C-1 YEAR	-40 to 125	OPA4187
OPA4187IPWRG4.B	Active	Production	TSSOP (PW) 14	2000 LARGE T&R	Yes	NIPDAU	Level-2-260C-1 YEAR	-40 to 125	OPA4187
OPA4187IRUMR	Active	Production	WQFN (RUM) 16	3000 LARGE T&R	Yes	SN	Level-1-260C-UNLIM	-40 to 125	OPA 4187
OPA4187IRUMR.B	Active	Production	WQFN (RUM) 16	3000 LARGE T&R	Yes	SN	Level-1-260C-UNLIM	-40 to 125	OPA 4187
OPA4187IRUMT	Active	Production	WQFN (RUM) 16	250 SMALL T&R	Yes	SN	Level-1-260C-UNLIM	-40 to 125	OPA 4187
OPA4187IRUMT.B	Active	Production	WQFN (RUM) 16	250 SMALL T&R	Yes	SN	Level-1-260C-UNLIM	-40 to 125	OPA 4187

(1) **Status:** For more details on status, see our [product life cycle](#).

(2) **Material type:** When designated, preproduction parts are prototypes/experimental devices, and are not yet approved or released for full production. Testing and final process, including without limitation quality assurance, reliability performance testing, and/or process qualification, may not yet be complete, and this item is subject to further changes or possible discontinuation. If available for ordering, purchases will be subject to an additional waiver at checkout, and are intended for early internal evaluation purposes only. These items are sold without warranties of any kind.

(3) **RoHS values:** Yes, No, RoHS Exempt. See the [TI RoHS Statement](#) for additional information and value definition.

(4) **Lead finish/Ball material:** Parts may have multiple material finish options. Finish options are separated by a vertical ruled line. Lead finish/Ball material values may wrap to two lines if the finish value exceeds the maximum column width.

(5) **MSL rating/Peak reflow:** The moisture sensitivity level ratings and peak solder (reflow) temperatures. In the event that a part has multiple moisture sensitivity ratings, only the lowest level per JEDEC standards is shown. Refer to the shipping label for the actual reflow temperature that will be used to mount the part to the printed circuit board.

(6) Part marking: There may be an additional marking, which relates to the logo, the lot trace code information, or the environmental category of the part.

Multiple part markings will be inside parentheses. Only one part marking contained in parentheses and separated by a "~" will appear on a part. If a line is indented then it is a continuation of the previous line and the two combined represent the entire part marking for that device.

Important Information and Disclaimer: The information provided on this page represents TI's knowledge and belief as of the date that it is provided. TI bases its knowledge and belief on information provided by third parties, and makes no representation or warranty as to the accuracy of such information. Efforts are underway to better integrate information from third parties. TI has taken and continues to take reasonable steps to provide representative and accurate information but may not have conducted destructive testing or chemical analysis on incoming materials and chemicals. TI and TI suppliers consider certain information to be proprietary, and thus CAS numbers and other limited information may not be available for release.

In no event shall TI's liability arising out of such information exceed the total purchase price of the TI part(s) at issue in this document sold by TI to Customer on an annual basis.

TAPE AND REEL INFORMATION

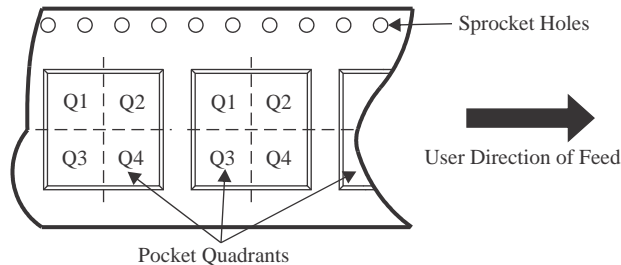
QUADRANT ASSIGNMENTS FOR PIN 1 ORIENTATION IN TAPE

*All dimensions are nominal

Device	Package Type	Package Drawing	Pins	SPQ	Reel Diameter (mm)	Reel Width W1 (mm)	A0 (mm)	B0 (mm)	K0 (mm)	P1 (mm)	W (mm)	Pin1 Quadrant
OPA187IDBVR	SOT-23	DBV	5	3000	180.0	8.4	3.23	3.17	1.37	4.0	8.0	Q3
OPA187IDBVT	SOT-23	DBV	5	250	180.0	8.4	3.23	3.17	1.37	4.0	8.0	Q3
OPA187IDBVTG4	SOT-23	DBV	5	250	180.0	8.4	3.23	3.17	1.37	4.0	8.0	Q3
OPA187IDGKR	VSSOP	DGK	8	2500	330.0	12.4	5.25	3.35	1.25	8.0	12.0	Q1
OPA187IDGKT	VSSOP	DGK	8	250	330.0	12.4	5.25	3.35	1.25	8.0	12.0	Q1
OPA187IDR	SOIC	D	8	2500	330.0	12.4	6.4	5.2	2.1	8.0	12.0	Q1
OPA2187IDGKR	VSSOP	DGK	8	2500	330.0	12.4	5.3	3.4	1.4	8.0	12.0	Q1
OPA2187IDGKRG4	VSSOP	DGK	8	2500	330.0	12.4	5.3	3.4	1.4	8.0	12.0	Q1
OPA2187IDGKT	VSSOP	DGK	8	250	180.0	12.4	5.3	3.4	1.4	8.0	12.0	Q1
OPA2187IDR	SOIC	D	8	2500	330.0	12.4	6.4	5.2	2.1	8.0	12.0	Q1
OPA2187IDRG4	SOIC	D	8	2500	330.0	12.4	6.4	5.2	2.1	8.0	12.0	Q1
OPA4187IDR	SOIC	D	14	2500	330.0	16.4	6.5	9.0	2.1	8.0	16.0	Q1
OPA4187IPWR	TSSOP	PW	14	2000	330.0	12.4	6.9	5.6	1.6	8.0	12.0	Q1
OPA4187IPWRG4	TSSOP	PW	14	2000	330.0	12.4	6.9	5.6	1.6	8.0	12.0	Q1
OPA4187IRUMR	WQFN	RUM	16	3000	330.0	12.4	4.25	4.25	1.15	8.0	12.0	Q2
OPA4187IRUMT	WQFN	RUM	16	250	180.0	12.4	4.25	4.25	1.15	8.0	12.0	Q2

TAPE AND REEL BOX DIMENSIONS

*All dimensions are nominal

Device	Package Type	Package Drawing	Pins	SPQ	Length (mm)	Width (mm)	Height (mm)
OPA187IDBVR	SOT-23	DBV	5	3000	213.0	191.0	35.0
OPA187IDBVT	SOT-23	DBV	5	250	213.0	191.0	35.0
OPA187IDBVTG4	SOT-23	DBV	5	250	213.0	191.0	35.0
OPA187IDGKR	VSSOP	DGK	8	2500	366.0	364.0	50.0
OPA187IDGKT	VSSOP	DGK	8	250	366.0	364.0	50.0
OPA187IDR	SOIC	D	8	2500	353.0	353.0	32.0
OPA2187IDGKR	VSSOP	DGK	8	2500	353.0	353.0	32.0
OPA2187IDGKRG4	VSSOP	DGK	8	2500	353.0	353.0	32.0
OPA2187IDGKT	VSSOP	DGK	8	250	213.0	191.0	35.0
OPA2187IDR	SOIC	D	8	2500	353.0	353.0	32.0
OPA2187IDRG4	SOIC	D	8	2500	353.0	353.0	32.0
OPA4187IDR	SOIC	D	14	2500	353.0	353.0	32.0
OPA4187IPWR	TSSOP	PW	14	2000	353.0	353.0	32.0
OPA4187IPWRG4	TSSOP	PW	14	2000	353.0	353.0	32.0
OPA4187IRUMR	WQFN	RUM	16	3000	367.0	367.0	35.0
OPA4187IRUMT	WQFN	RUM	16	250	210.0	185.0	35.0

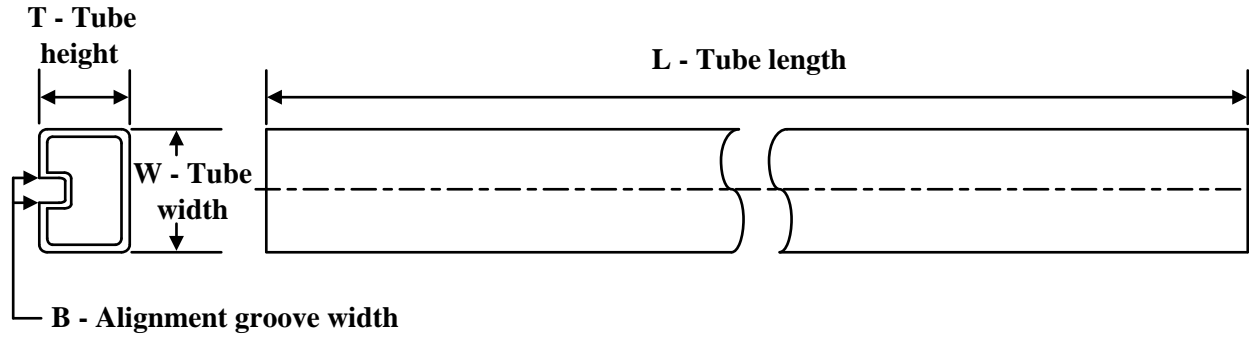
TUBE

*All dimensions are nominal

Device	Package Name	Package Type	Pins	SPQ	L (mm)	W (mm)	T (μm)	B (mm)
OPA187ID	D	SOIC	8	75	506.6	8	3940	4.32
OPA187ID.B	D	SOIC	8	75	506.6	8	3940	4.32
OPA187IDG4	D	SOIC	8	75	506.6	8	3940	4.32
OPA187IDG4.B	D	SOIC	8	75	506.6	8	3940	4.32
OPA2187ID	D	SOIC	8	75	506.6	8	3940	4.32
OPA2187ID.B	D	SOIC	8	75	506.6	8	3940	4.32
OPA4187ID	D	SOIC	14	50	506.6	8	3940	4.32
OPA4187ID.B	D	SOIC	14	50	506.6	8	3940	4.32
OPA4187IDG4	D	SOIC	14	50	506.6	8	3940	4.32
OPA4187IDG4.B	D	SOIC	14	50	506.6	8	3940	4.32
OPA4187IPW	PW	TSSOP	14	90	530	10.2	3600	3.5
OPA4187IPW.B	PW	TSSOP	14	90	530	10.2	3600	3.5



D0014A

PACKAGE OUTLINE

SOIC - 1.75 mm max height

SMALL OUTLINE INTEGRATED CIRCUIT



4220718/A 09/2016

NOTES:

1. All linear dimensions are in millimeters. Dimensions in parenthesis are for reference only. Dimensioning and tolerancing per ASME Y14.5M.
2. This drawing is subject to change without notice.
3. This dimension does not include mold flash, protrusions, or gate burrs. Mold flash, protrusions, or gate burrs shall not exceed 0.15 mm, per side.
4. This dimension does not include interlead flash. Interlead flash shall not exceed 0.43 mm, per side.
5. Reference JEDEC registration MS-012, variation AB.

EXAMPLE BOARD LAYOUT

D0014A

SOIC - 1.75 mm max height

SMALL OUTLINE INTEGRATED CIRCUIT



LAND PATTERN EXAMPLE
SCALE:8X



SOLDER MASK DETAILS

4220718/A 09/2016

NOTES: (continued)

- 6. Publication IPC-7351 may have alternate designs.
- 7. Solder mask tolerances between and around signal pads can vary based on board fabrication site.

GENERIC PACKAGE VIEW

RUM 16

WQFN - 0.8 mm max height

4 x 4, 0.65 mm pitch

PLASTIC QUAD FLATPACK - NO LEAD

This image is a representation of the package family, actual package may vary.
Refer to the product data sheet for package details.

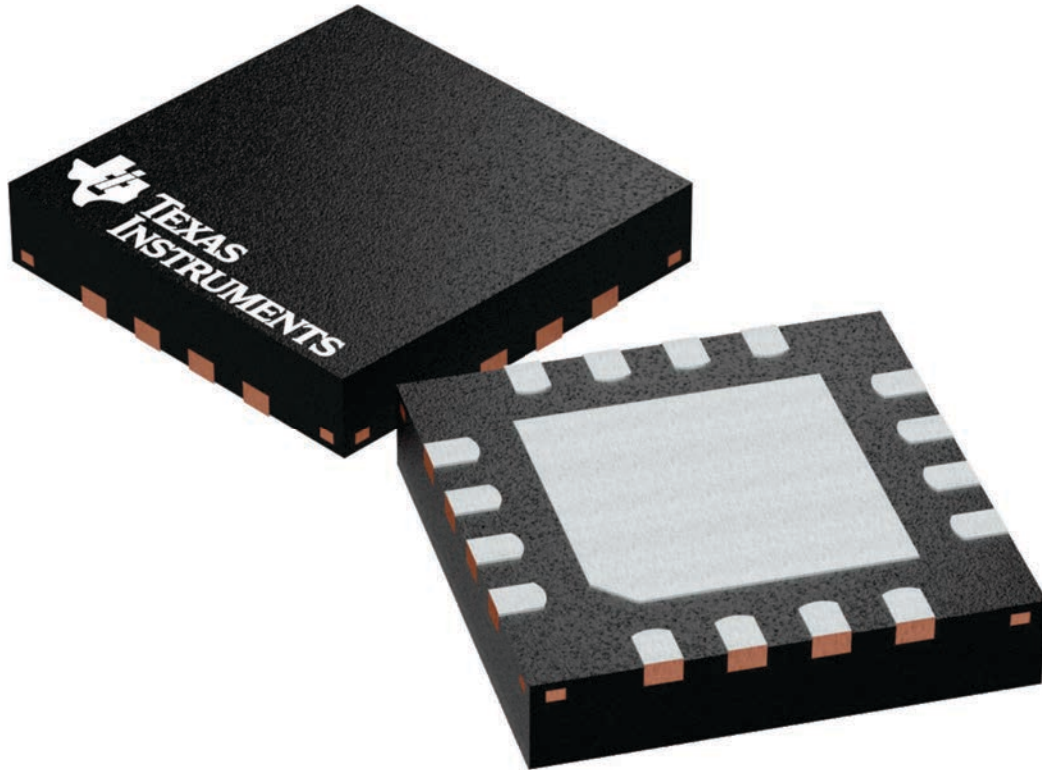

4224843/A

RUM (S-PQFP-N16)

PLASTIC QUAD FLATPACK

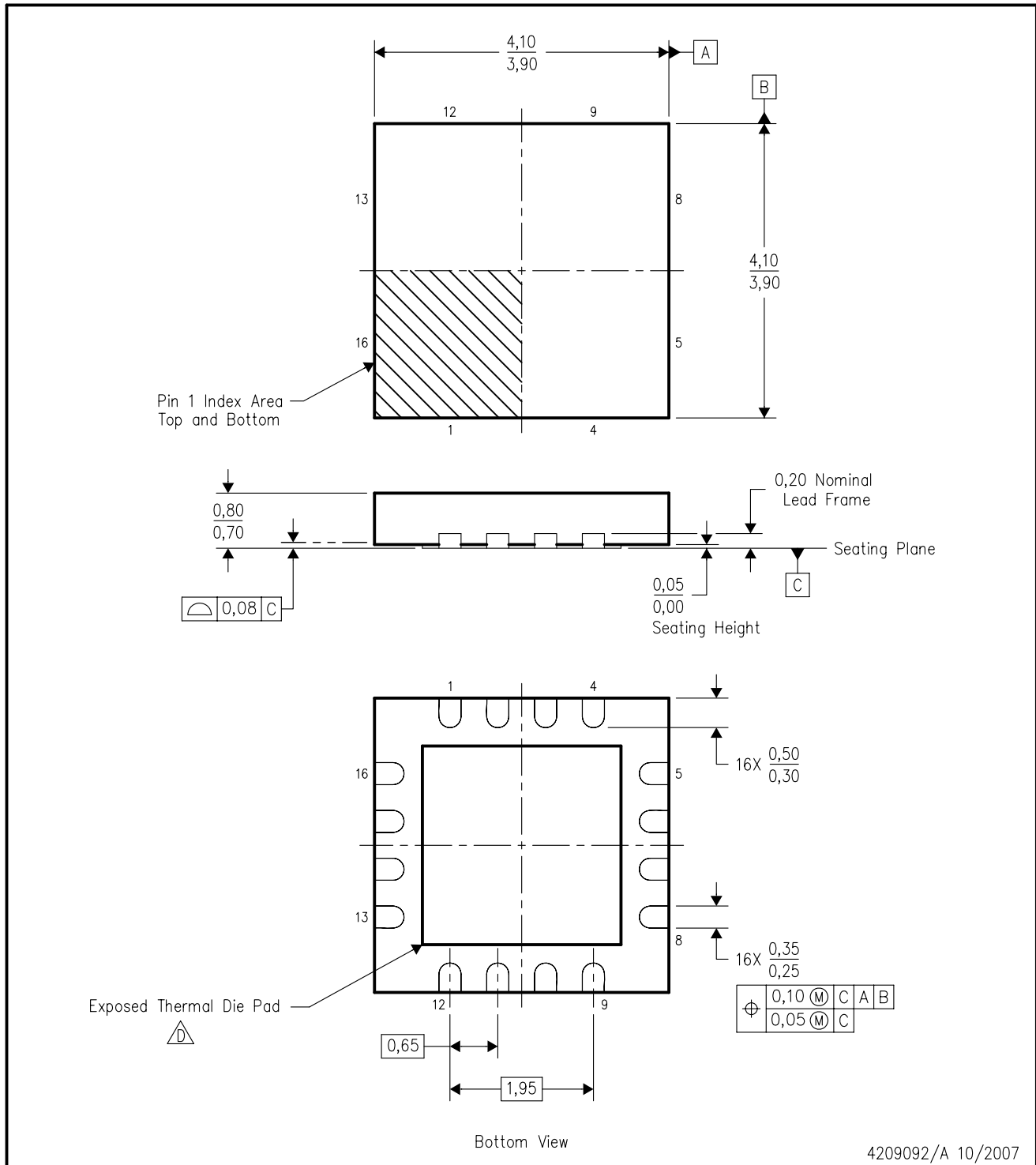

4209092/A 10/2007

- NOTES:
- A. All linear dimensions are in millimeters. Dimensioning and tolerancing per ASME Y14.5M-1994.
 - B. This drawing is subject to change without notice.
 - C. QFN (Quad Flatpack No-Lead) package configuration.
 -  The package thermal pad must be soldered to the board for thermal and mechanical performance. See the Product Data Sheet for details regarding the exposed thermal pad dimensions.
 - E. Package complies to JEDEC MO-220 variation WGGC-3.

THERMAL INFORMATION

This package incorporates an exposed thermal pad that is designed to be attached directly to an external heatsink. The thermal pad must be soldered directly to the printed circuit board (PCB). After soldering, the PCB can be used as a heatsink. In addition, through the use of thermal vias, the thermal pad can be attached directly to the appropriate copper plane shown in the electrical schematic for the device, or alternatively, can be attached to a special heatsink structure designed into the PCB. This design optimizes the heat transfer from the integrated circuit (IC).

For information on the Quad Flatpack No-Lead (QFN) package and its advantages, refer to Application Report, QFN/SON PCB Attachment, Texas Instruments Literature No. SLUA271. This document is available at www.ti.com.

The exposed thermal pad dimensions for this package are shown in the following illustration.

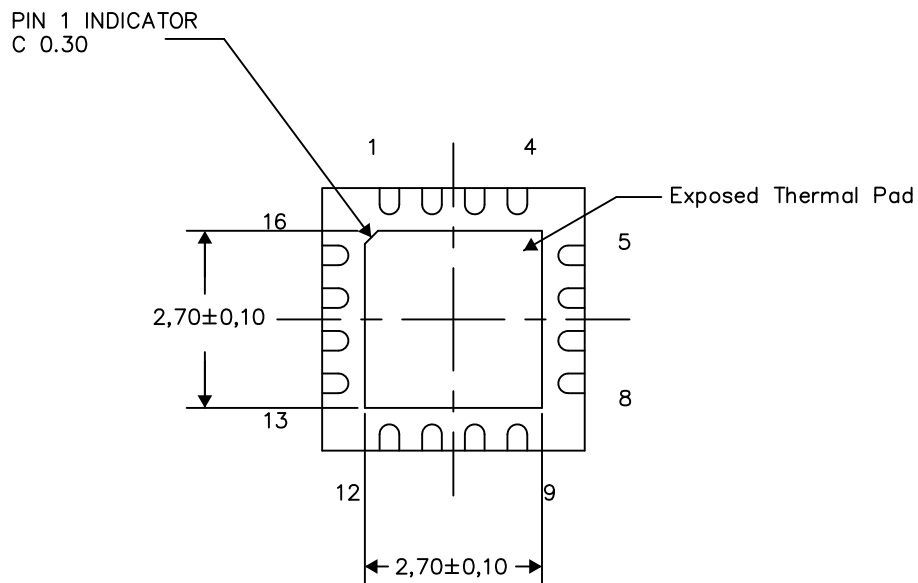

Bottom View

Exposed Thermal Pad Dimensions

4209093-2/F 09/15

NOTES: All linear dimensions are in millimeters



D0008A

PACKAGE OUTLINE

SOIC - 1.75 mm max height

SMALL OUTLINE INTEGRATED CIRCUIT



4214825/C 02/2019

NOTES:

- Linear dimensions are in inches [millimeters]. Dimensions in parenthesis are for reference only. Controlling dimensions are in inches. Dimensioning and tolerancing per ASME Y14.5M.
- This drawing is subject to change without notice.
- This dimension does not include mold flash, protrusions, or gate burrs. Mold flash, protrusions, or gate burrs shall not exceed $.006$ [0.15] per side.
- This dimension does not include interlead flash.
- Reference JEDEC registration MS-012, variation AA.

EXAMPLE BOARD LAYOUT

D0008A

SOIC - 1.75 mm max height

SMALL OUTLINE INTEGRATED CIRCUIT



LAND PATTERN EXAMPLE
 EXPOSED METAL SHOWN
 SCALE:8X



SOLDER MASK DETAILS

4214825/C 02/2019

NOTES: (continued)

- 6. Publication IPC-7351 may have alternate designs.
- 7. Solder mask tolerances between and around signal pads can vary based on board fabrication site.

EXAMPLE STENCIL DESIGN

D0008A

SOIC - 1.75 mm max height

SMALL OUTLINE INTEGRATED CIRCUIT



SOLDER PASTE EXAMPLE
BASED ON .005 INCH [0.125 MM] THICK STENCIL
SCALE:8X

4214825/C 02/2019

NOTES: (continued)

8. Laser cutting apertures with trapezoidal walls and rounded corners may offer better paste release. IPC-7525 may have alternate design recommendations.
9. Board assembly site may have different recommendations for stencil design.

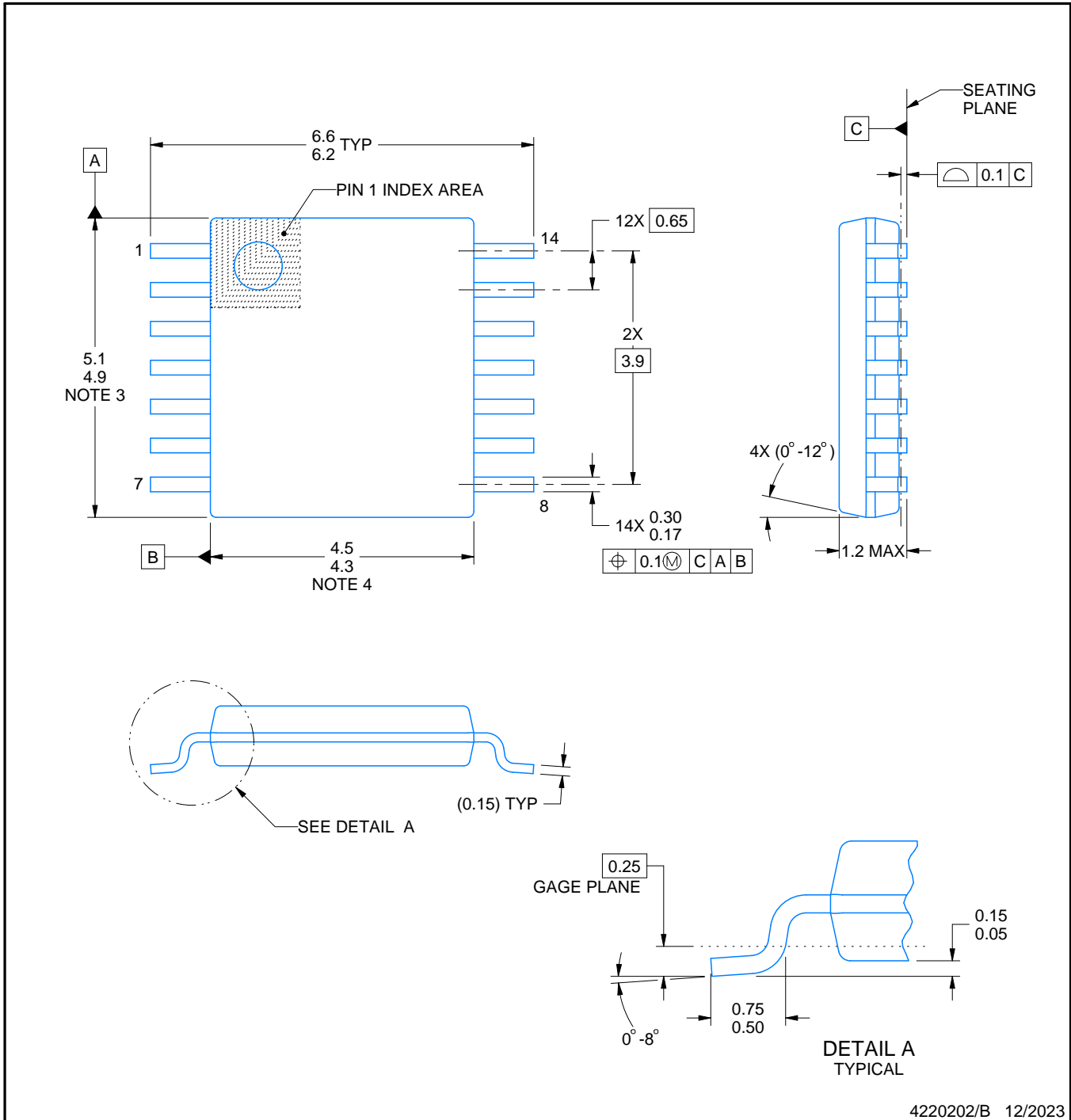
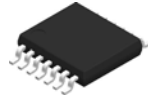

4220202/B 12/2023

NOTES:

1. All linear dimensions are in millimeters. Any dimensions in parenthesis are for reference only. Dimensioning and tolerancing per ASME Y14.5M.
2. This drawing is subject to change without notice.
3. This dimension does not include mold flash, protrusions, or gate burrs. Mold flash, protrusions, or gate burrs shall not exceed 0.15 mm per side.
4. This dimension does not include interlead flash. Interlead flash shall not exceed 0.25 mm per side.
5. Reference JEDEC registration MO-153.

EXAMPLE BOARD LAYOUT

PW0014A

TSSOP - 1.2 mm max height

SMALL OUTLINE PACKAGE

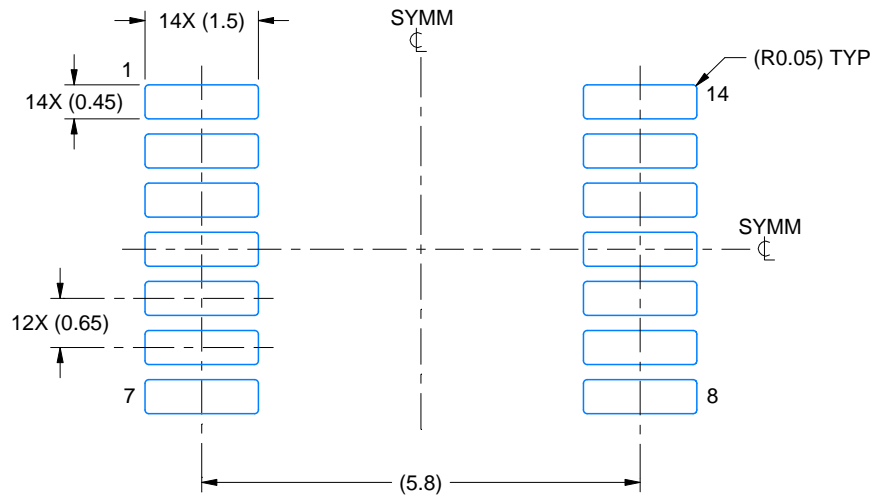

LAND PATTERN EXAMPLE
EXPOSED METAL SHOWN
SCALE: 10X

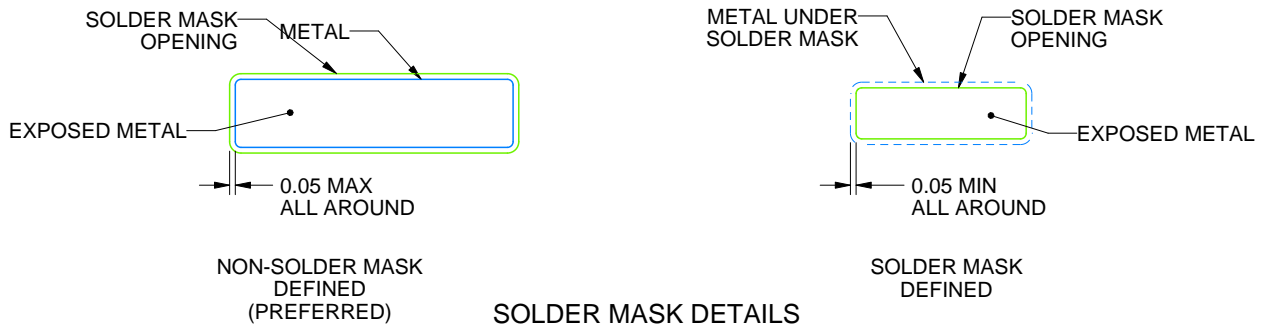

4220202/B 12/2023

NOTES: (continued)

- 6. Publication IPC-7351 may have alternate designs.
- 7. Solder mask tolerances between and around signal pads can vary based on board fabrication site.

EXAMPLE STENCIL DESIGN

PW0014A

TSSOP - 1.2 mm max height

SMALL OUTLINE PACKAGE

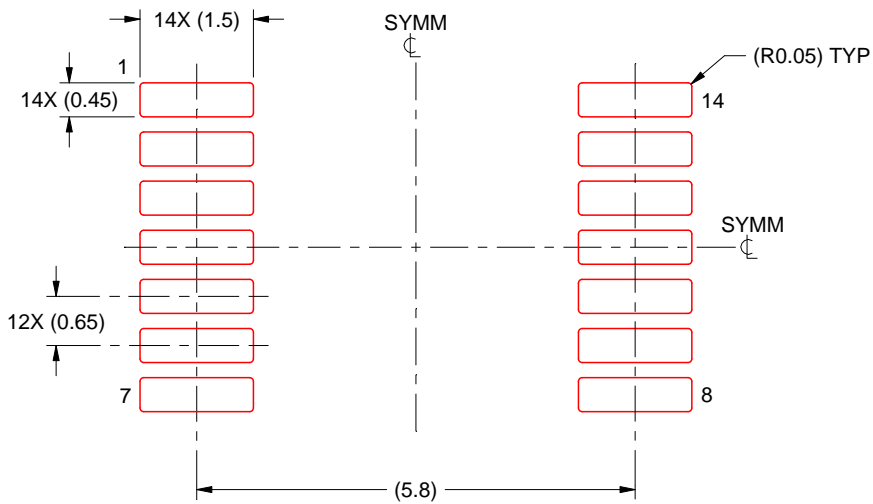

SOLDER PASTE EXAMPLE
BASED ON 0.125 mm THICK STENCIL
SCALE: 10X

4220202/B 12/2023

NOTES: (continued)

8. Laser cutting apertures with trapezoidal walls and rounded corners may offer better paste release. IPC-7525 may have alternate design recommendations.
9. Board assembly site may have different recommendations for stencil design.

EXAMPLE BOARD LAYOUT

DBV0005A

SOT-23 - 1.45 mm max height

SMALL OUTLINE TRANSISTOR



LAND PATTERN EXAMPLE
EXPOSED METAL SHOWN
SCALE:15X



SOLDER MASK DETAILS

4214839/K 08/2024

NOTES: (continued)

- 6. Publication IPC-7351 may have alternate designs.
- 7. Solder mask tolerances between and around signal pads can vary based on board fabrication site.

EXAMPLE STENCIL DESIGN

DBV0005A

SOT-23 - 1.45 mm max height

SMALL OUTLINE TRANSISTOR



SOLDER PASTE EXAMPLE
BASED ON 0.125 mm THICK STENCIL
SCALE:15X

4214839/K 08/2024

NOTES: (continued)

8. Laser cutting apertures with trapezoidal walls and rounded corners may offer better paste release. IPC-7525 may have alternate design recommendations.
9. Board assembly site may have different recommendations for stencil design.

DGK0008A



PACKAGE OUTLINE

VSSOP - 1.1 mm max height

SMALL OUTLINE PACKAGE

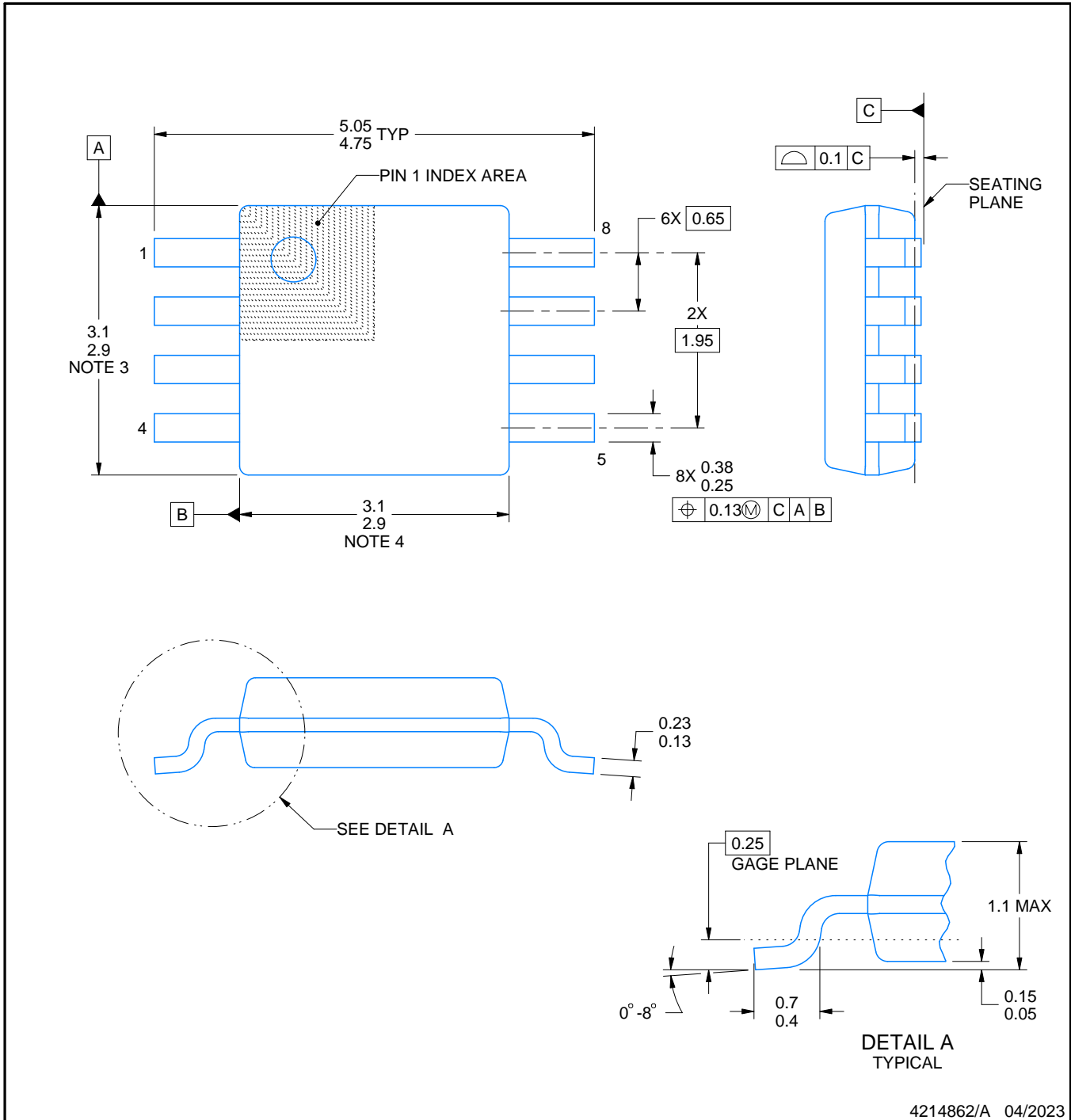

4214862/A 04/2023

NOTES:

PowerPAD is a trademark of Texas Instruments.

1. All linear dimensions are in millimeters. Any dimensions in parenthesis are for reference only. Dimensioning and tolerancing per ASME Y14.5M.
2. This drawing is subject to change without notice.
3. This dimension does not include mold flash, protrusions, or gate burrs. Mold flash, protrusions, or gate burrs shall not exceed 0.15 mm per side.
4. This dimension does not include interlead flash. Interlead flash shall not exceed 0.25 mm per side.
5. Reference JEDEC registration MO-187.

EXAMPLE BOARD LAYOUT

DGK0008A

™ VSSOP - 1.1 mm max height

SMALL OUTLINE PACKAGE



LAND PATTERN EXAMPLE
EXPOSED METAL SHOWN
SCALE: 15X

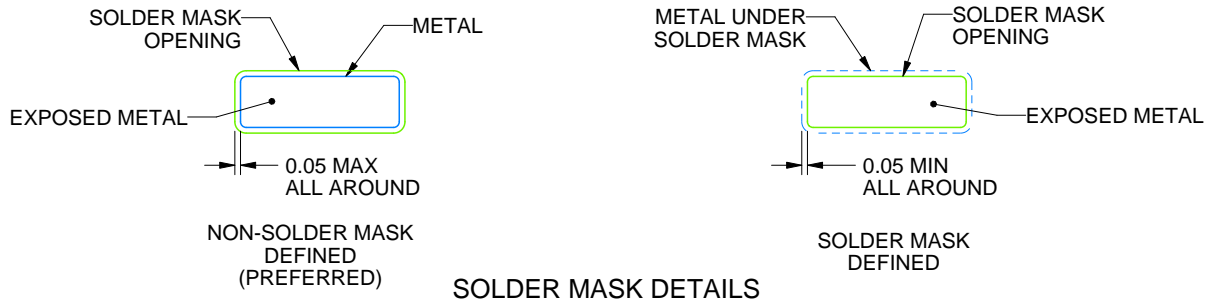

4214862/A 04/2023

NOTES: (continued)

6. Publication IPC-7351 may have alternate designs.
7. Solder mask tolerances between and around signal pads can vary based on board fabrication site.
8. Vias are optional depending on application, refer to device data sheet. If any vias are implemented, refer to their locations shown on this view. It is recommended that vias under paste be filled, plugged or tented.
9. Size of metal pad may vary due to creepage requirement.

EXAMPLE STENCIL DESIGN

DGK0008A

™ VSSOP - 1.1 mm max height

SMALL OUTLINE PACKAGE



SOLDER PASTE EXAMPLE
SCALE: 15X

4214862/A 04/2023

NOTES: (continued)

11. Laser cutting apertures with trapezoidal walls and rounded corners may offer better paste release. IPC-7525 may have alternate design recommendations.
12. Board assembly site may have different recommendations for stencil design.

IMPORTANT NOTICE AND DISCLAIMER

TI PROVIDES TECHNICAL AND RELIABILITY DATA (INCLUDING DATASHEETS), DESIGN RESOURCES (INCLUDING REFERENCE DESIGNS), APPLICATION OR OTHER DESIGN ADVICE, WEB TOOLS, SAFETY INFORMATION, AND OTHER RESOURCES "AS IS" AND WITH ALL FAULTS, AND DISCLAIMS ALL WARRANTIES, EXPRESS AND IMPLIED, INCLUDING WITHOUT LIMITATION ANY IMPLIED WARRANTIES OF MERCHANTABILITY, FITNESS FOR A PARTICULAR PURPOSE OR NON-INFRINGEMENT OF THIRD PARTY INTELLECTUAL PROPERTY RIGHTS.

These resources are intended for skilled developers designing with TI products. You are solely responsible for (1) selecting the appropriate TI products for your application, (2) designing, validating and testing your application, and (3) ensuring your application meets applicable standards, and any other safety, security, regulatory or other requirements.

These resources are subject to change without notice. TI grants you permission to use these resources only for development of an application that uses the TI products described in the resource. Other reproduction and display of these resources is prohibited. No license is granted to any other TI intellectual property right or to any third party intellectual property right. TI disclaims responsibility for, and you fully indemnify TI and its representatives against any claims, damages, costs, losses, and liabilities arising out of your use of these resources.

TI's products are provided subject to [TI's Terms of Sale](#), [TI's General Quality Guidelines](#), or other applicable terms available either on ti.com or provided in conjunction with such TI products. TI's provision of these resources does not expand or otherwise alter TI's applicable warranties or warranty disclaimers for TI products. Unless TI explicitly designates a product as custom or customer-specified, TI products are standard, catalog, general purpose devices.

TI objects to and rejects any additional or different terms you may propose.

Copyright © 2026, Texas Instruments Incorporated

Last updated 10/2025