

Automotive Emergency Call Audio Subsystem Reference Design



Description

The efficiency and diagnostics necessary for automotive emergency call (eCall) systems generate unique requirements for the audio subsystem, such as recording diagnostics, speaker diagnostics, and low power consumption. This design shows how to use TI's automotive, two-channel audio codec and a class-D audio amplifier for eCall applications. The reference design also highlights critical design factors and benefits of TI's design such as low power consumption and efficiency, loud and clear audio output, and integrated diagnostics and protection.

Resources

TIDA-060048	Design Folder
TAC5312-Q1	Product Folder
TAS5441-Q1	Product Folder
TPD2E007	Product Folder
LMR43620-Q1	Product Folder
TPS7A52-Q1	Product Folder

Features

- Passes CISPR 25 class 5 radiated emissions limits
- 22W through a 4Ω load output power
- Integrated input recording fault diagnostics and protection
- Integrated speaker load diagnostics
- Register settings included for the TAC5312-Q1

Applications

- [Emergency call \(eCall\)](#)
- [Telematics control unit](#)
- [Domain gateway](#)

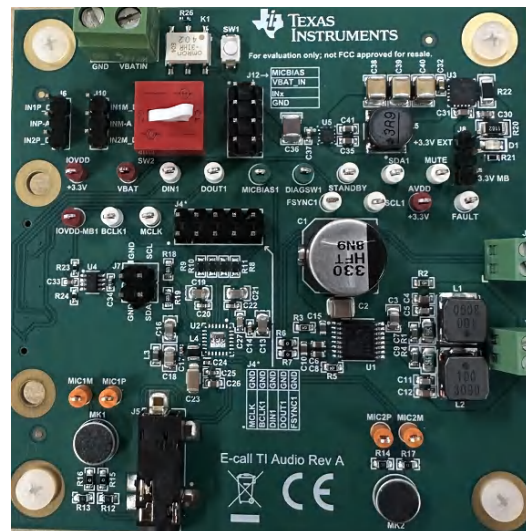
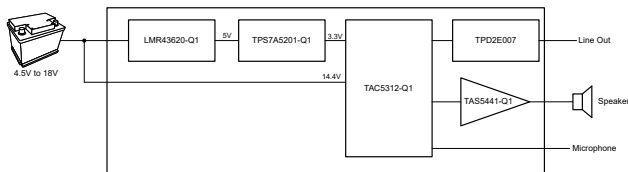
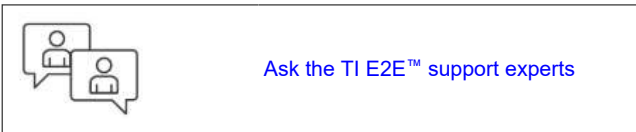

1 System Description

1.1 Key System Specifications

Table 1-1. Key System Specifications

PARAMETER	SPECIFICATIONS	MINIMUM	TYPICAL	MAXIMUM	UNIT
Input voltage	12V Car battery	4.5	14.4	40	V
Standby current	TAS5441-Q1 Standby mode, TAC5312-Q1 reset		5		μA
Speaker load		2	4	6	Ω
Output power	4Ω Load			8	W
ESD protection on line out	IEC 61000-4-2 contact		±8		kV
	IEC 61000-4-2 air-gap		±15		
Audio input, audio output	Digital audio I ² S input, speaker output microphone input, digital audio I ² S output				
ESD protection	ESD protection needed on line output				
EMC requirements, EMI requirements	CISPR 25 class 5 radiated emissions				
Operating temperature		-40		125	°C
Form factor	3.35in × 4.5in				

2 System Overview

Governing bodies around the world have implemented specific legislation to require automotive companies to install emergency call (eCall) systems to reduce emergency response times and save lives. eCall systems are activated during a collision or emergency situation and automatically facilitate a call to emergency services. The state of a vehicle after a collision is difficult to predict and can include a disconnected battery, trapped passengers, and a noisy environment. For this reason, the eCall module requires an independent battery power source and must be able to sustain hands-free calls for approximately ten minutes depending on specific regional legislation. Therefore, the audio devices selected for this reference design are excellent choices for low power consumption while still enabling a loud and clear conversation with an emergency operator. In addition, both the TAC5312-Q1 codec and TAS5441-Q1 speaker amplifier include integrated diagnostics and protection features that optimize design and reduce the system cost.

Figure 2-1 shows the entire block diagram containing power management, an MCU, a connectivity module, and audio. The MCU receives inputs from the rest of the vehicle and activates the call if an accident occurs. The power management is able to run off of the main battery of a car or a smaller back-up battery integrated into the eCall module. The wireless module makes the call and uses a full duplex digital audio signal to interface with the audio subsystem. The audio subsystem drives the speakers and handles the microphone input.

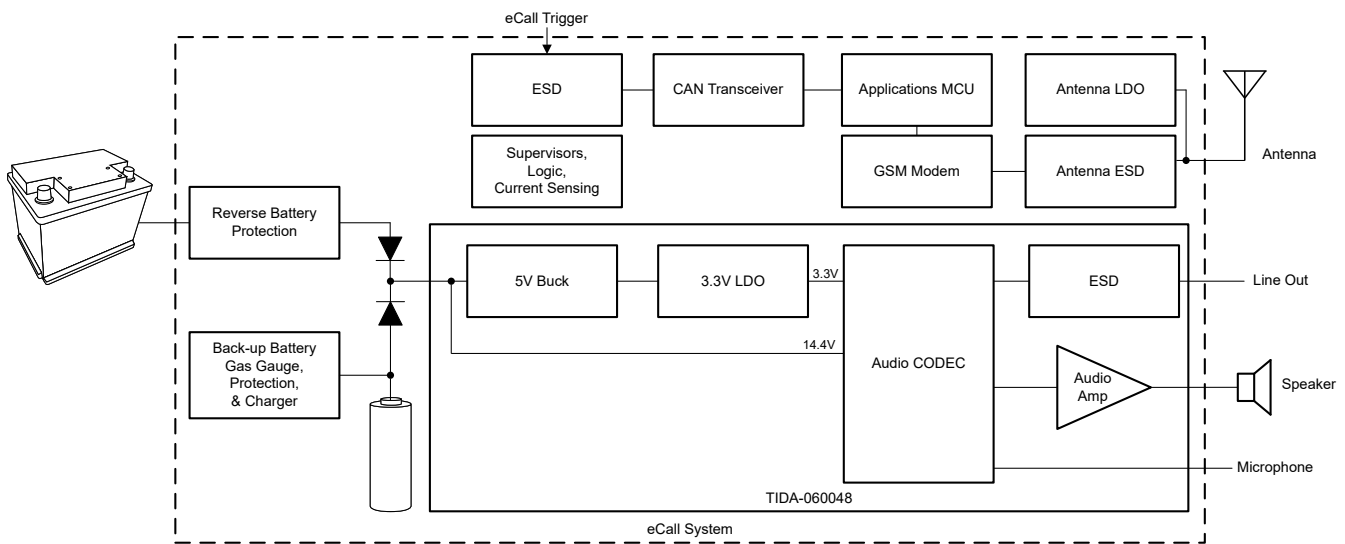

Figure 2-1. System Integration of eCall Subsystem

The audio subsystem consists of a class-D audio amplifier and an audio codec. The audio codec connects the digital audio input from the connectivity module to the class-D amplifier which drives the speaker. The codec must also convert the microphone inputs to a digital signal to communicate back to the connectivity module.

2.1 Block Diagram

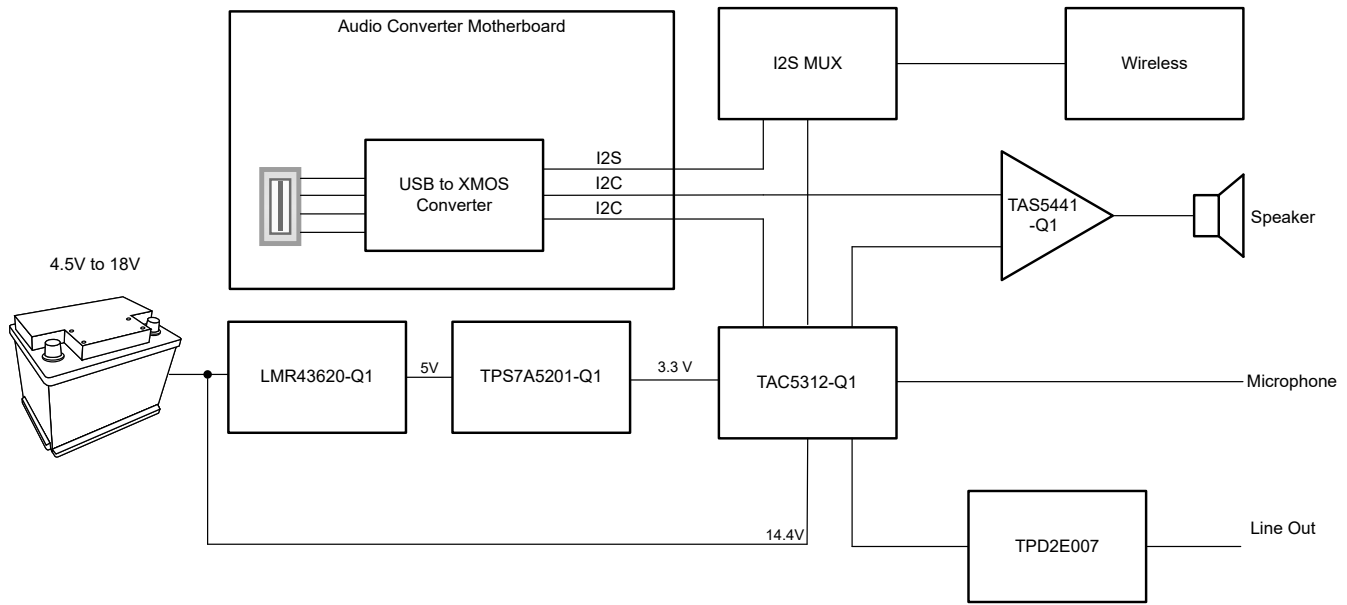

Figure 2-2. TIDA-060048 Block Diagram

2.2 Design Considerations

2.2.1 Codec Design

The automotive audio codec must be designed to operate in a wide range of harsh environments. As greater amounts of electronics are integrated into automotive systems, the system complexity and potential for faults also increase. Microphones typically used in eCall systems are relied on for algorithms like beamforming, active noise cancellation, or speech recognition. These algorithms depend on reliable data from microphones, and if one or more microphones in the system fail, the processing of unreliable data leads to erroneous calculations. In these applications, microphones can be placed in remote locations far away from the PCB, such as in a ceiling console, close to the engine, or at different positions in the passenger cabin. The remote placement of the microphone makes a wire harness to interface with the rest of the electronics necessary. Although extreme care is taken to prevent failure, over time these harnesses can degrade, resulting in faulty microphone connections.

The TAC5312-Q1 provides integrated diagnostic monitoring features, highlighted in [Section 2.3.1](#), that replace discrete detection schemes by determining when an input fault condition has occurred in firmware. With this information, the system can select how to respond and adjust system algorithms to handle the error. Typical eCall applications favor the use of electric condenser microphones (ECM) for ease of mounting, interfacing, pickup directionality, moisture, and dust protection. These ECM microphones operate between 2V to 10V and can have large voltage swings. TAC5312-Q1 can handle up to a 10V_{RMS} swing directly while supporting DC-coupled fault diagnostics on each input pin and report faults over I²C.

eCall systems are typically space-constrained and rely on integrated components to maximize efficiency. TAC5312-Q1 reduces external component count by operating on a single 3.3V supply to support codec data conversion and a high-voltage MICBIAS supply through an integrated boost converter.

2.2.2 Class-D Amplifier

The class-D amplifier must maintain sufficient output power to drive the speaker to the specified audio level with sufficient audio quality. The amplifier must also have high efficiency and good EMI and EMC performance. In addition, many eCall systems require speaker diagnostics and IC protection circuitry.

Class-D amplifiers are used because of excellent efficiency, which is critical in the eCall application. The high efficiency is achieved by using metal-oxide semiconductor field-effect transistors (MOSFET) that switch to drive a bridge-tied load. However, the switching causes more electromagnetic radiation than other classes of amplifiers. Texas Instruments has several class-D amplifiers that use BD mode modulation, which reduces

the ripple current that flows through the inductor. This improves the EMC performance and uses smaller components. This design is tested for radiated emissions according to CISPR-25.

Diagnostic and protection coverage is needed for eCall applications because of the unknown nature of the environment after a collision. If a speaker is faulty after a collision, the information can be sent to the call center so that the center knows that the speaker does not work. This coverage also helps to retrieve load diagnostics before there is a collision so that any problems with the system can be fed back to the driver for maintenance. Within the eCall module, it is unlikely for there to be an exposure to a high-voltage event. However, the connectors leaving the eCall module are in danger. Specifically, the speaker cables that connect the speaker to the eCall module can be connected to ground or battery during installation, maintenance, or during an accident. While no class-D amplifier can operate while such a condition is maintained on the output lines, without protection, even a momentary incident can damage a class-D amplifier. The TAS5441-Q1 has integrated protection for these events, reducing the need for external components, and the device can report problems over I²C. Damage can also occur to the class-D amplifier on the power supply input. Because the amplifier has to drive several watts on the output speaker, it is beneficial to power an audio amplifier directly from the battery. However, most class-D amplifiers cannot survive common battery conditions that can occur on the battery line. The TAS5441-Q1 integrates the protection necessary to survive a 40V load dump, which means that the only external protection necessary when operating off of the battery is a reverse battery protection diode.

2.2.2.1 Audio Filter Design

To improve the audio quality and to reduce electromagnetic emissions, an output filter is needed for the TAS5441-Q1. These output filters can use many components, for instance, [Figure 2-3](#) shows an LC reconstruction filter with common-mode and differential capacitors and RC snubbers.

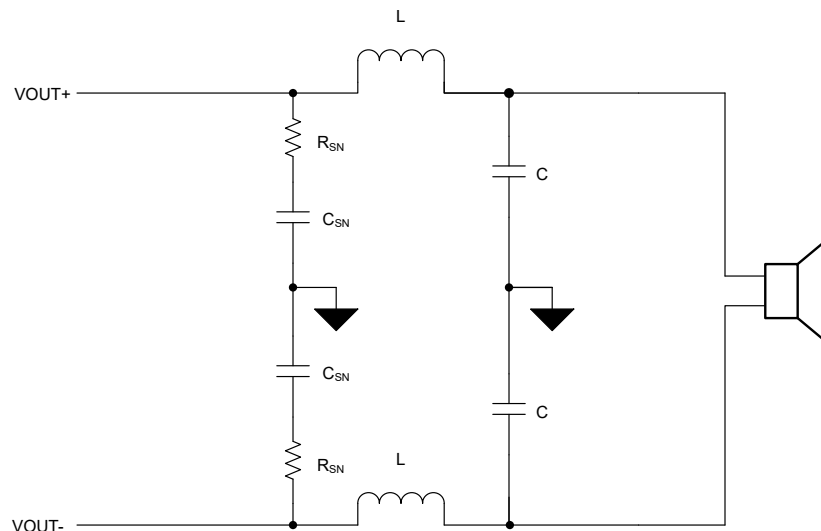

Figure 2-3. Class-D Amplifier LC Filter With RC Snubber

The RC snubbers help reduce electromagnetic emissions, however, snubbers are not needed for many applications. The radiated emissions testing done on this design did not use the RC snubbers. Figure 2-4 shows the output filter without the RC snubber network.

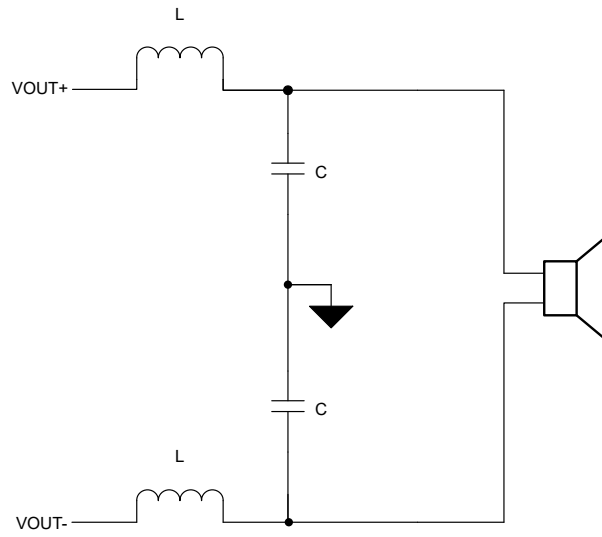

Figure 2-4. Class-D Amplifier LC Filter

When designing the output filter, consider the filter as two single-ended outputs. For this reason, R_L is considered to be 2Ω instead of 4Ω in the following design equations. A second-order Butterworth filter provides a flat pass-band response and a reasonable sharp roll off. Critically damp the filter, which occurs when:

$$Q = \frac{1}{\sqrt{2}} \quad (1)$$

The equations for C and L can be derived from the following two equations.

$$Q = R_L \times \sqrt{\frac{C}{L}} \quad (2)$$

$$\omega_c^2 = \frac{1}{C \times L} \quad (3)$$

Both the inductor and capacitor are chosen by choosing the cutoff frequency of the filter. For audio voice applications, 30kHz or above is a reasonable number. The equation to choose the inductance is:

$$L = \frac{R_L \times \sqrt{2}}{\omega_c} \quad (4)$$

$$L = \frac{2\Omega \times \sqrt{2}}{2 \times \pi \times 34\text{kHz}} = 10\mu\text{H} \quad (5)$$

Further considerations for the inductor include shielding to improve EMC performance, saturation current, and low core losses. The TAS5441-Q1 overcurrent shutdown protection is 2.4A to 3.5A. Reaching the saturation current of an inductor lowers the inductance, so choosing the saturation level to be around or above the shutdown current is a safe choice. The inductor chosen for this design is the VLS6045EX-100M-H which is magnetically shielded, has low DC resistance, and has a typical saturation current of 3.9A.

Choose the capacitors using the following equation:

$$C = \frac{1}{\omega_c \times R_L \times \sqrt{2}} \quad (6)$$

$$C = \frac{1}{2 \times \pi \times 34\text{kHz} \times 4 \times \sqrt{2}} = 1.66\mu\text{F} \quad (7)$$

To improve EMC performance, the cutoff frequency can be lowered slightly more by raising the capacitor slightly. For this design, a capacitor of 2.2 μ F is used, which results in the frequency response shown in [Figure 2-5](#).

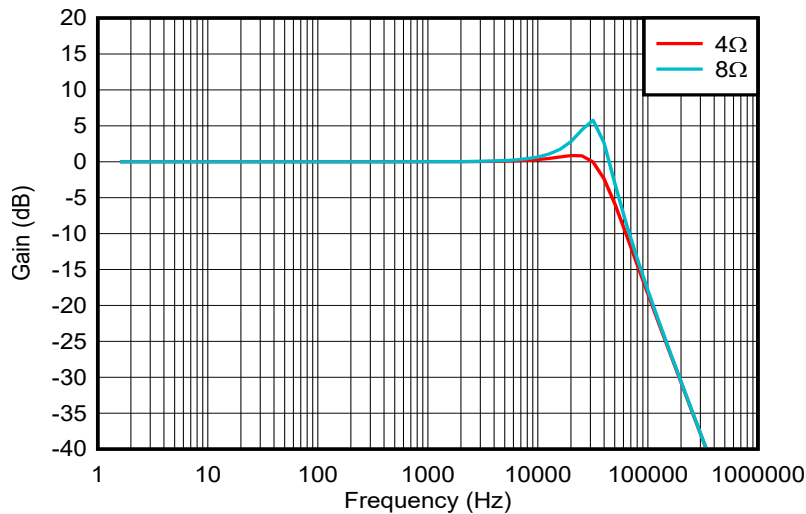

Figure 2-5. Frequency Response of LC Filter, L = 10 μ H, C = 2.2 μ F, R = 4 Ω , 8 Ω BTL

While this change assists with EMC performance, the change does drop the gain at 20kHz to 2dB instead of 1dB. Tradeoffs must be made between audio quality and EMC testing.

For improved EMC performance, the RC snubbers can be added back in, but this design is tested without them.

For the full derivation of the design equations see the [LC Filter Design](#) application report.

2.2.3 Power Design

The voltage regulators are chosen to support a current draw up to 2A from the 3.3V supply rail. TAC5312-Q1 is optimized to operate on a single 3.3V supply for AVDD, IOVDD, BSTVDD, and BSTSW pins. AVDD and IOVDD pins draw less than 50mA of current. BSTVDD is a switching current due to the internal boost operating in discontinuous mode resulting in an average current draw of 250mA and peak current draw of 1.3A. The VBATIN pin on TAC5312-Q1 is a reference voltage for input fault diagnostics and does not draw current.

The only external components necessary for the two regulators are input and output capacitors. Input capacitors improve transient performance and can improve noise rejection. Output capacitors are necessary for voltage stability.

The LMR43620-Q1 device has a recommendation that an input capacitor of at least 4.7 μ F is used to reduce ripple current and isolate switching noise from surrounding circuits. The voltage rating must be higher than the maximum input, so a 50V capacitor is used. The recommended output capacitors are three 22 μ F capacitors to improve transient response and add stability for a 5V output. The TPS7A52-Q1 device has a recommendation that a 10 μ F or greater input capacitor is used to minimize input impedance. For this design, the output capacitors following LMR43620-Q1 is tied to the input of TPS7A52-Q1. The output capacitor minimum is 10 μ F for this design.

2.2.4 EMC, EMI Design Considerations

The layout must be designed with EMC considerations. See [Section 4.1.3](#) for more information. The LMR43620-Q1 switching frequency can be adjusted from 200kHz to 2.2MHz and in this design the switching frequency is set to 2.2MHz reduce EMI and avoid AM band interference. Additionally, the TAS5441-Q1 switching frequency can be programmed to be either 400kHz or 500kHz. Changing the switching frequency is useful to shift where the emissions occur. If multiple devices in the system operate at the same frequency, then it is more difficult to pass the radiated emissions limits.

2.3 Highlighted Products

2.3.1 TAC5312-Q1

The TAC5312-Q1 is a high-performance stereo codec with $10V_{RMS}$ differential input, 104dB stereo ADC, and $2V_{RMS}$, 114dB stereo DAC channels. The TAC5312-Q1 supports a multitude of input and output configurations such as differential- and single-ended inputs and outputs, both microphone and line-in inputs on the ADC channel, input and output fault diagnostics, and either line out or headphone loads at the DAC output. These parameters enable TAC5312-Q1 to act as an interface between the MCU and speaker amplifiers in various audio applications in the infotainment and cluster fields.

The stereo audio codec supports sampling rates from 8kHz to 768kHz, integrates a programmable high-voltage microphone bias, and input diagnostic circuitry for direct-coupled inputs. The device incorporates diagnostic circuitry designed for detecting and determining the status of input and output connections. The device supports the following diagnostics:

- Inputs shorted to ground
- Inputs shorted to MICBIAS
- Input open circuit
- Input pins shorted together
- Input overvoltage detection
- Inputs shorted to VBAT
- Output overcurrent detection
- Output virtual ground detection

The codec also integrates digital volume control, a low-jitter phase-locked loop (PLL), a programmable high-pass filter (HPF), programmable EQ and biquad filters, low-latency filter modes, and secondary audio serial interface (ASI) support. The serial control bus supports the I²C and SPI protocol, whereas the serial audio data bus is programmable for I²S, left-justified or right-justified, or time division multiplexing (TDM) modes.

Where neither analog nor digital signal processing are required, the device can be put in a special analog signal bypass mode. This mode significantly reduces power consumption, because most of the device is powered down during this bypass operation. These high-performance features along with a single, 3.3V supply operation, makes TAC5312-Q1 an excellent choice for space-constrained automotive systems.

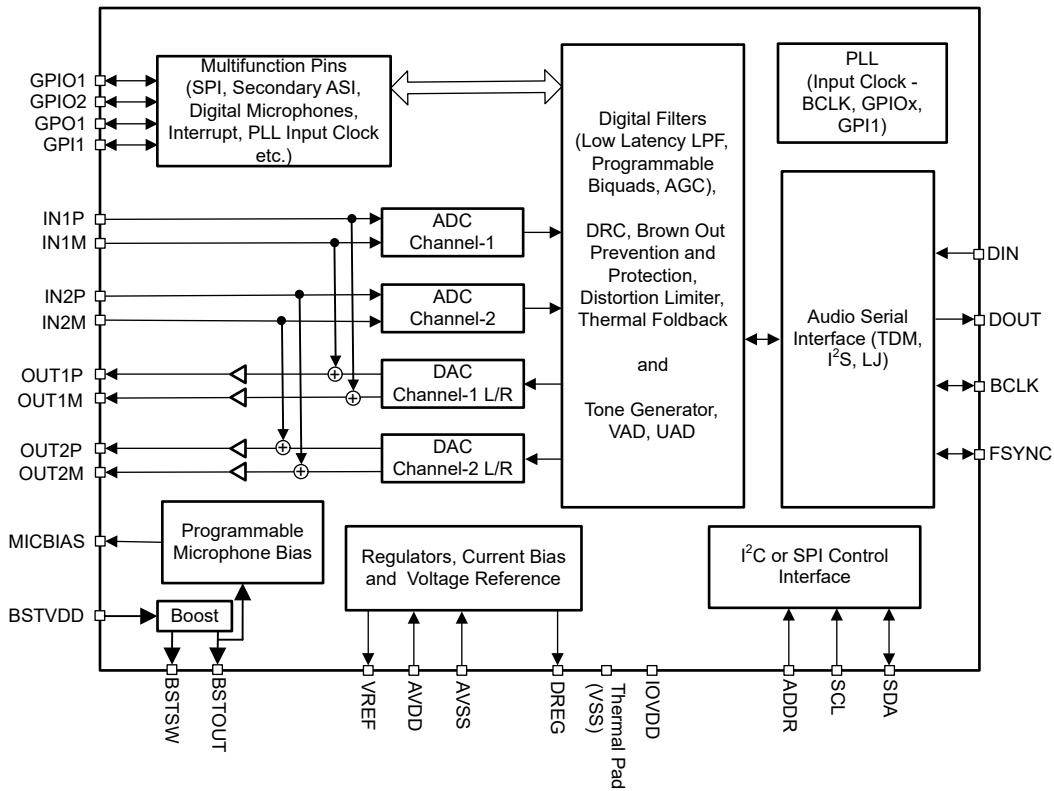

Figure 2-6. TAC5312-Q1 Functional Block Diagram

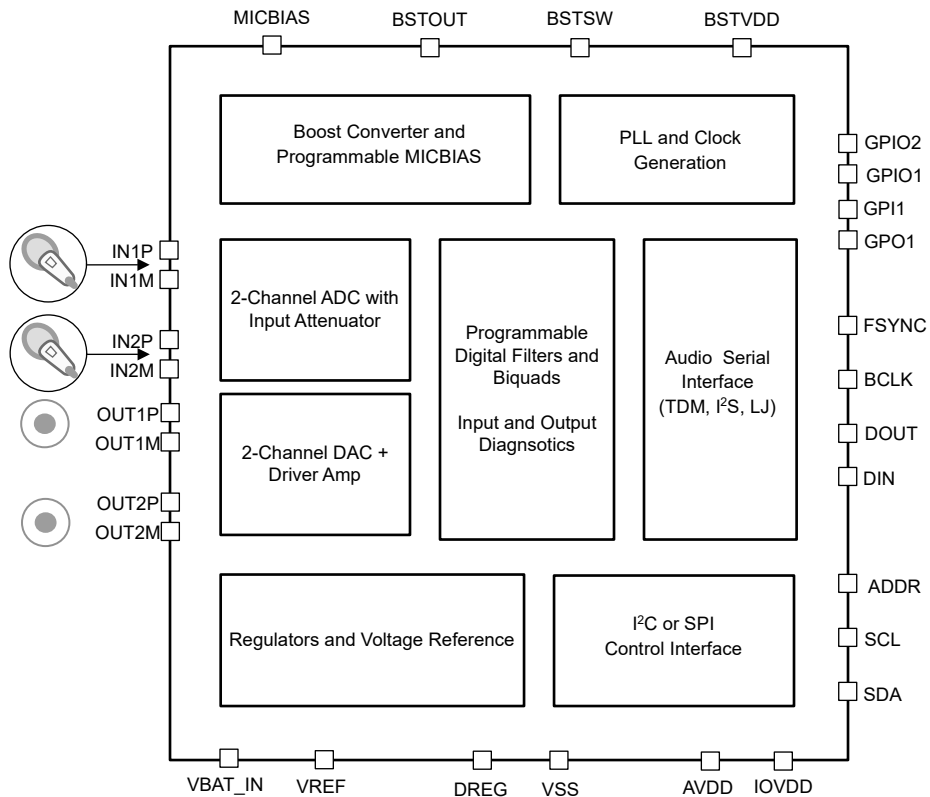

Figure 2-7. TAC5312-Q1 Simplified Diagram

2.3.2 TAS5441-Q1

The TAS5441-Q1 is a mono digital audio amplifier, an excellent choice for use in automotive emergency call (eCall), telematics, instrument cluster, and infotainment applications. The device provides up to 22W into 4Ω at less than 10% THD+N from a 14.4V_{dc} automotive battery. The wide operating voltage range and excellent efficiency make the device an excellent choice for start-stop support or running from a backup battery when required. The integrated load-dump protection reduces external voltage clamp cost and size, and the onboard load diagnostics report the status of the speaker through I2C. The design uses an ultra-efficient class-D technology developed by Texas Instruments with features added for the automotive industry. This technology allows for reduced power consumption, reduced heat, and reduced peak currents in the electrical system. The device realizes an audio sound system design with smaller size and lower weight than traditional class-AB designs. The device incorporates load diagnostic circuitry designed for detecting and determining the status of output connections. The device supports the following diagnostics:

- Short-to-GND
- Short-to-PVDD
- Short across load
- Open load

The device reports the presence of any of the short or open conditions to the system through I²C register read. The load diagnostic function runs on deassertion of STANDBY or when the device is in a fault state such as dc detect, overcurrent, overvoltage, undervoltage, and overtemperature. During this test, the outputs are in a Hi-Z state. The device determines whether the output is a short-to-GND, short-to-PVDD, open load, or shorted load. The load diagnostic biases the output, which therefore requires limiting the capacitance value for proper functioning. The load diagnostic test takes approximately 229ms to run. The check phase repeats up to 5 times if a fault is present or a large capacitor-to-GND is present on the output.

On detection of an open load, the output still operates. On detection of any other fault condition, the output goes into a Hi-Z state, and the device checks the load continuously until removal of the fault condition. After detection of a normal output condition, the audio output starts. The load diagnostics run after every other overvoltage event. The load diagnostic for open load only has I2C reporting. All other faults have I2C and FAULT pin assertion.

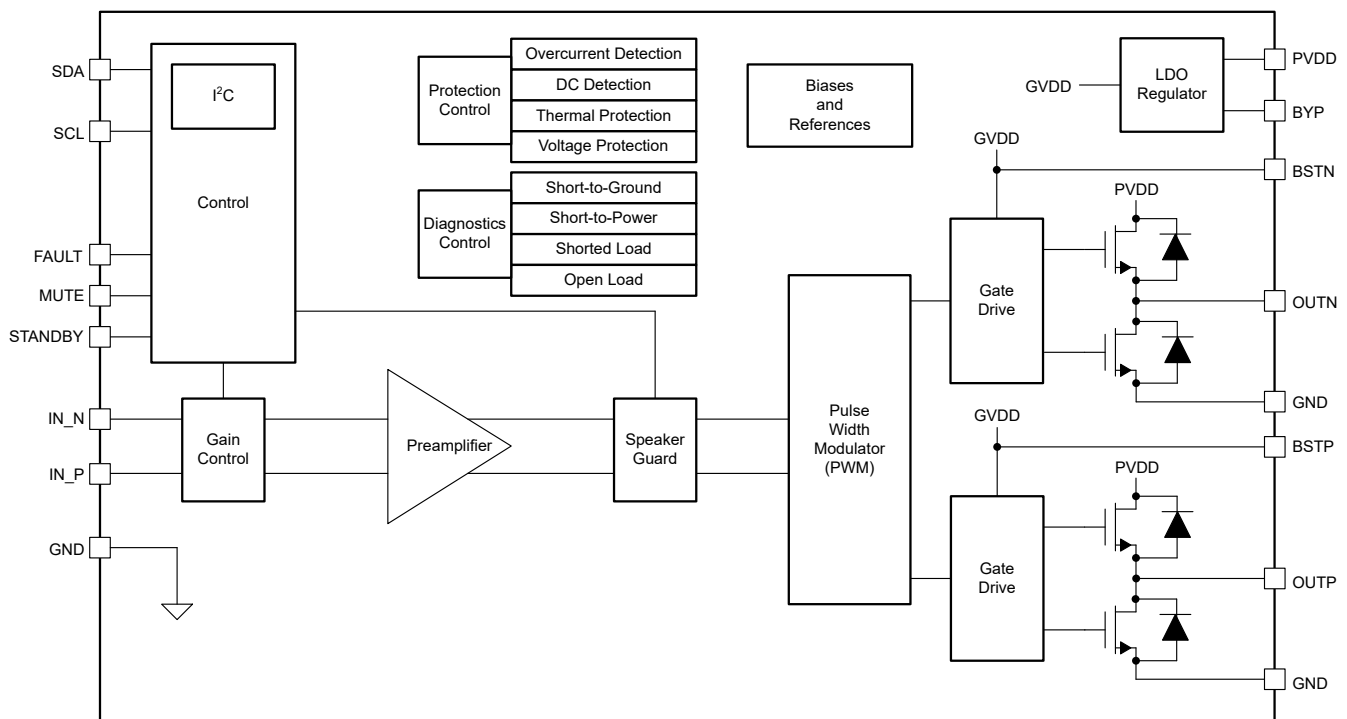

Figure 2-8. TAS5411-Q1 Functional Block Diagram

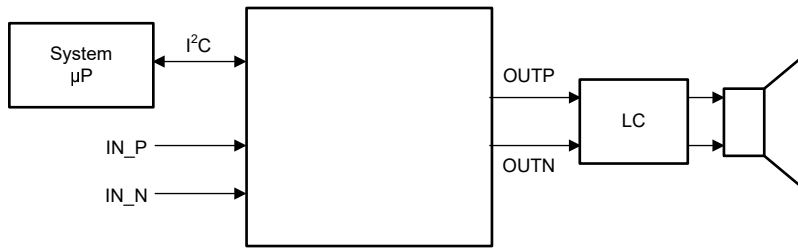

Figure 2-9. TAS5411-Q1 Simplified Block Diagram

2.3.3 LMR43620-Q1

The LMR43620-Q1 high-voltage linear regulator operates over a 3V to 36V input voltage range. With only 2.5μA (typical) quiescent current at light load and optimization for ultra-low EMI, the device is an excellent choice for standby microcontrol-unit systems especially in automotive applications. The device has an output current capability of 1A or 2A and offers fixed output voltages of 3.3V, 5V, or an adjustable voltage level. The device features a 2.2MHz switching frequency that is adjustable to meet customer requirements, thermal shutdown, and short-circuit protection to prevent damage during overtemperature and overcurrent conditions.

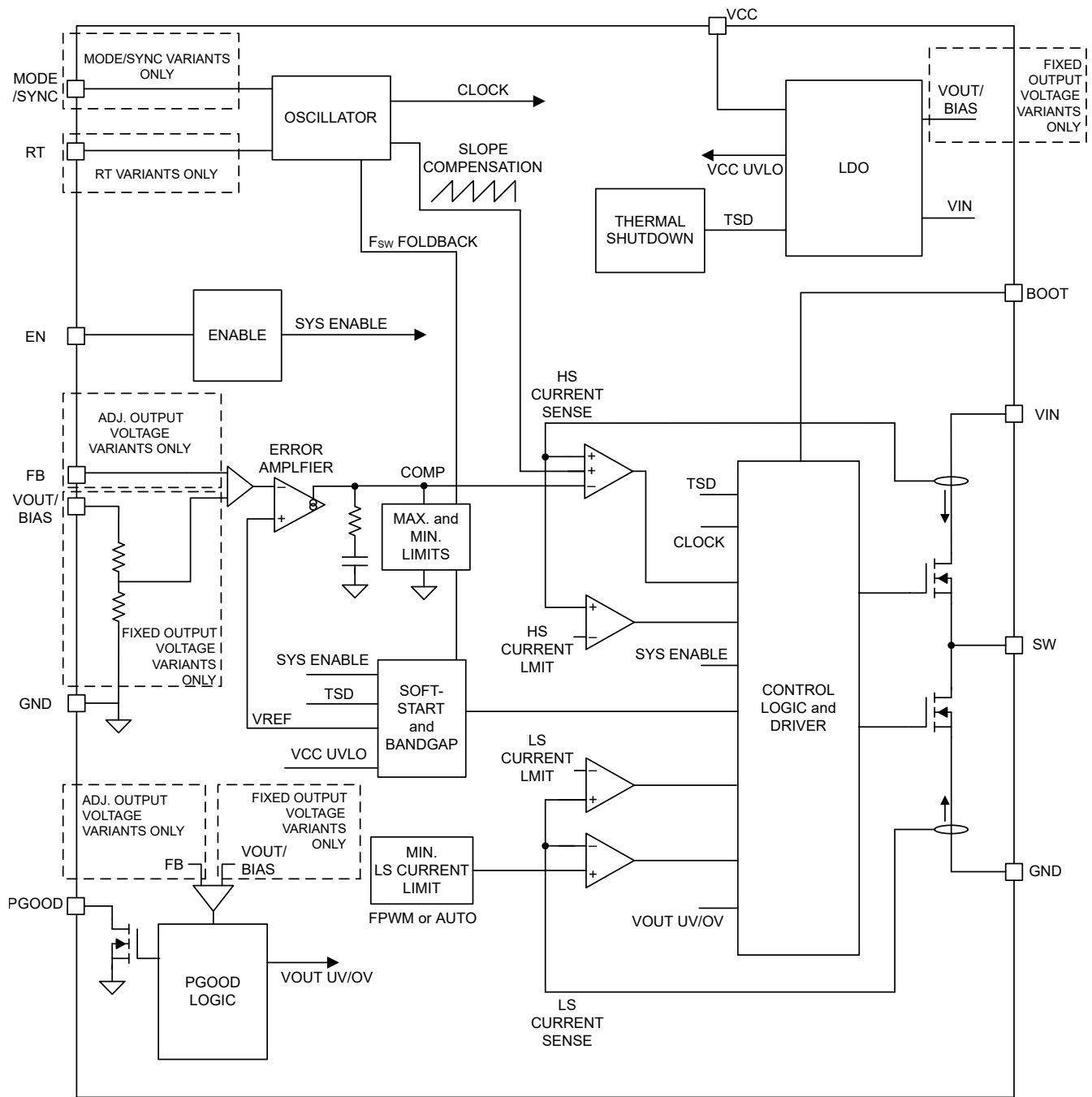

Figure 2-10. LMR43620-Q1 Functional Diagram

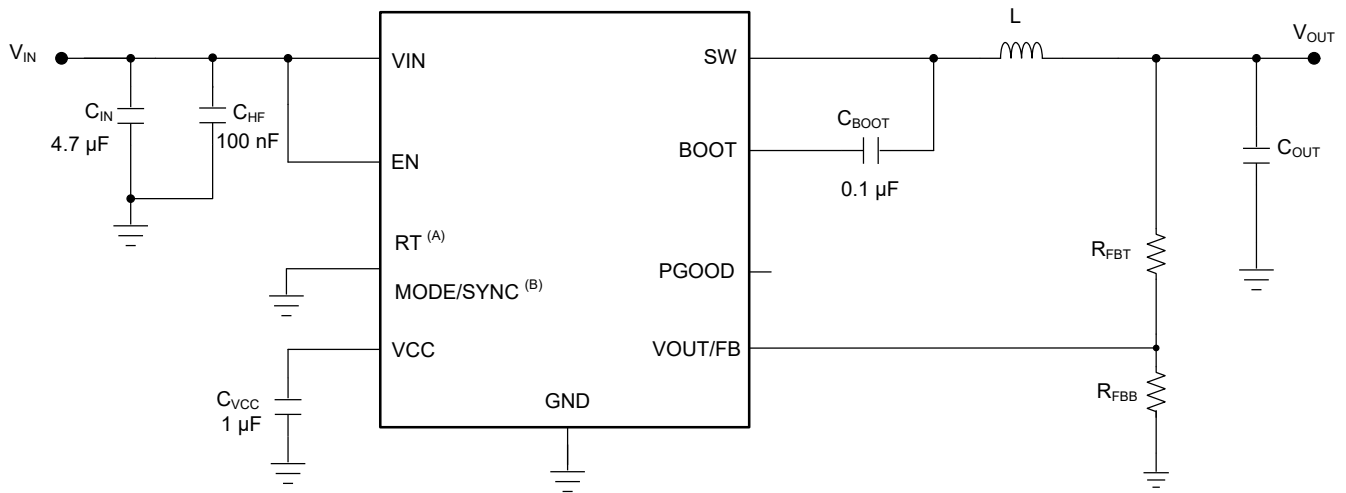

Figure 2-11. LMR43620-Q1 Simplified Schematic

2.3.4 TPS7A52-Q1

The TPS7A52 series of linear regulators are low-noise devices designed for power noise-sensitive applications. A precision band-gap and error amplifier provide 1% accuracy overtemperature. These devices have thermal-shutdown, current-limit, and reverse-current protections for added safety. Shutdown mode is enabled by pulling the EN pin low. The shutdown current in this mode goes down to 25μA (typical). The TPS709 series is available in VQFN (20) packages with wettable flank.

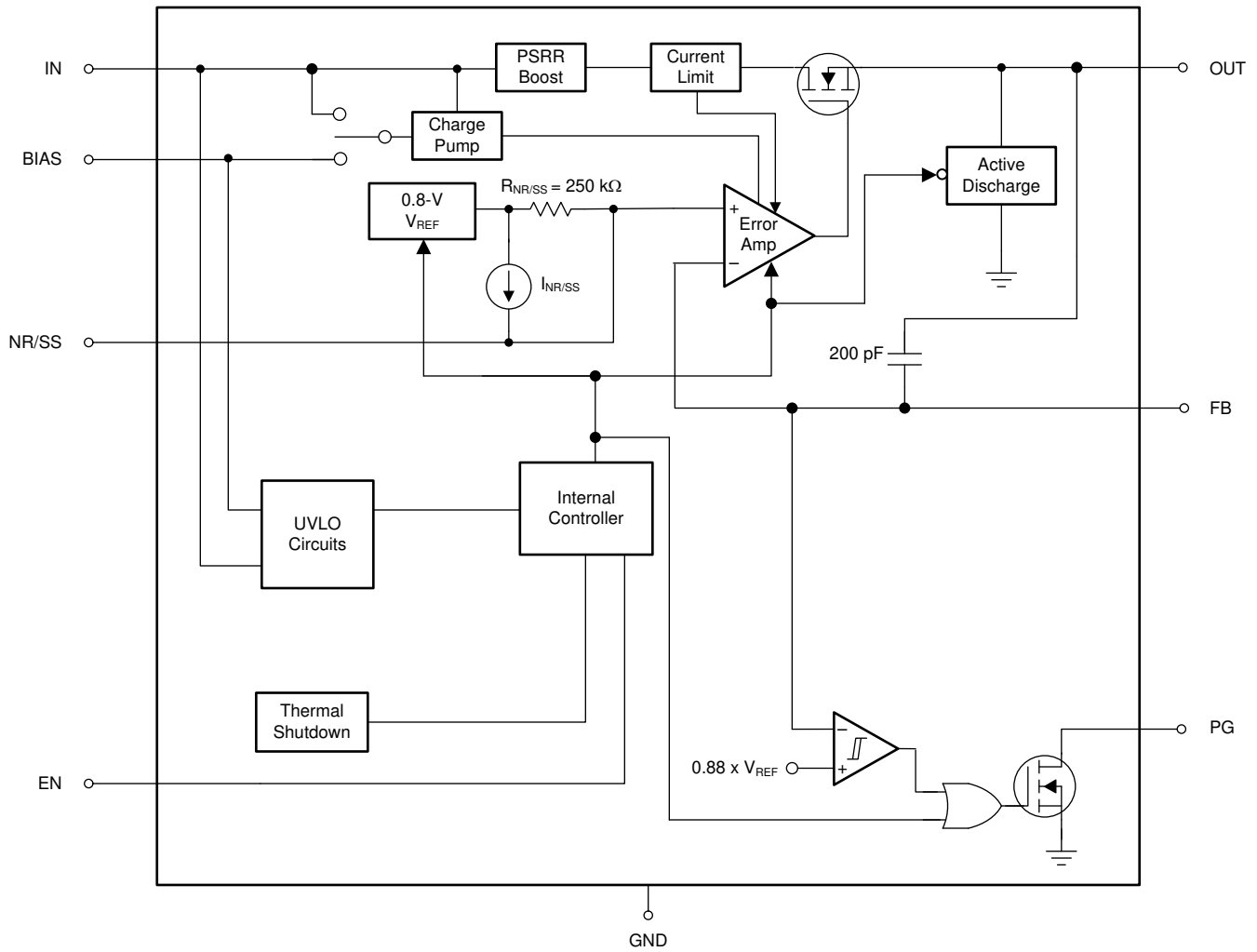

Figure 2-12. TPS709-Q1 Functional Block Diagram

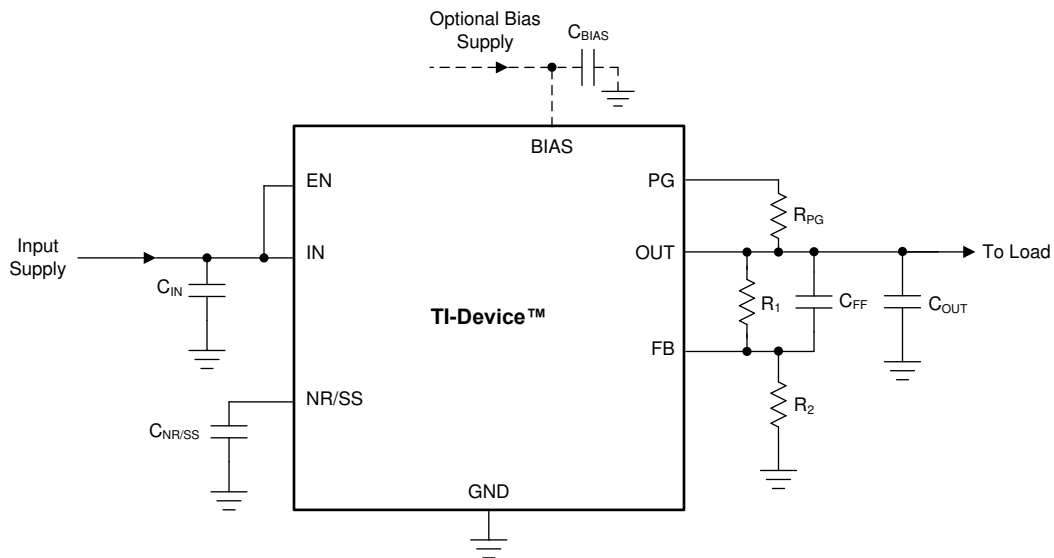

Figure 2-13. TPS709-Q1 Simplified Schematic

2.3.5 TPD2E007

This device is a transient voltage suppressor (TVS) based electrostatic discharge (ESD) protection device designed to offer system-level ESD designs for a wide range of portable and industrial applications. The back-to-back diode array allows AC-coupled or negative-going data transmission (audio interface, LVDS, RS-485, RS-232, and so forth) without compromising signal integrity. This device exceeds the IEC 61000-4-2 (level 4) ESD protection and is an excellent choice for providing system-level ESD protection for the internal ICs when placed near the connector.

The TPD2E007 is offered in a 4-bump PicoStar™ package and 3-pin SOT (DGK) packages. The PicoStar package (YFM), with only a 0.15mm (maximum) package height, is recommended for ultra space-saving applications where the package height is a key concern. The PicoStar package can be used in either embedded printed-circuit board (PCB) applications or in surface-mount applications. The industry standard SOT package offers a straightforward board layout option in legacy designs.

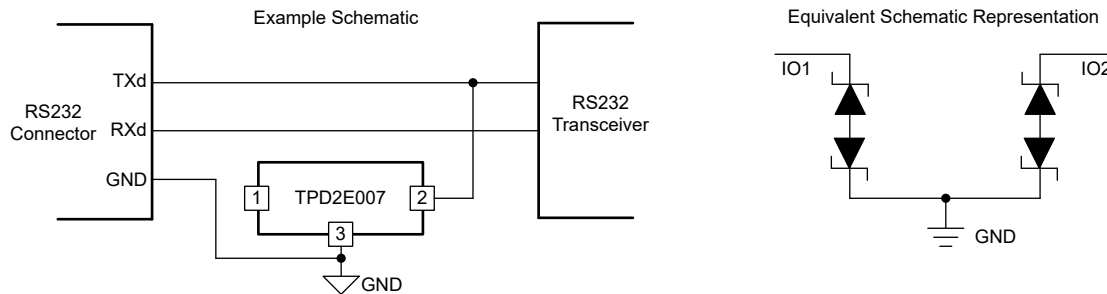

Figure 2-14. TPD2E007 Simplified Schematic

3 Hardware, Testing Requirements, and Test Results

3.1 Hardware Requirements

3.1.1 Board Connection

The hardware design includes the blocks discussed previously as well as a AC-MB to send I²C commands to the TAS5441-Q1, the TAC312-Q1, and to monitor input diagnostics. In the final system, the AC-MB controller is replaced with an automotive compatible MCU. Figure 3-1 shows the block diagram of the design with the AC-MB. When evaluating this design; however, using the I²C bus is all that is needed, so any I2C controller can be used.

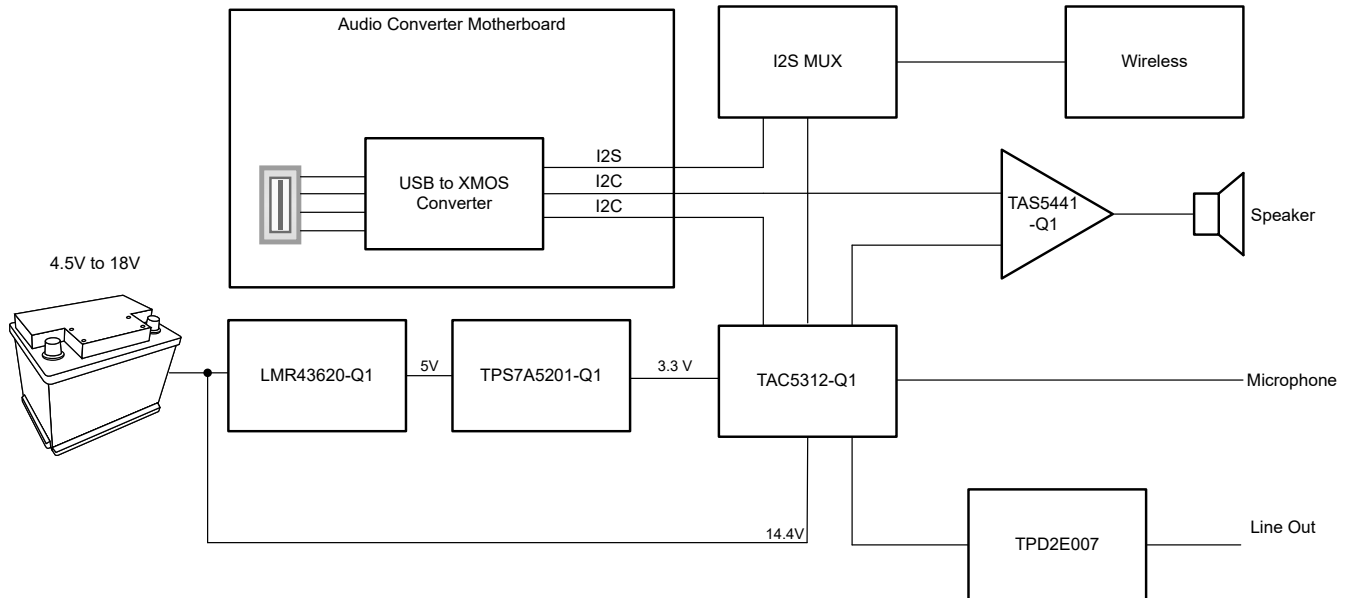

Figure 3-1. TIDA-060048 Full Block Diagram

Table 3-1. Connectors

DESIGNATOR	NAME	DESCRIPTION
J1	Speaker Output	Connect the speaker load across pins 1 and 2 of J1
J2	Power Supply Input	Power supply input (5V–18V)
J3	Codec Line Output	Connect directly to MCU or speaker amplifier across pins 1 and 2 of J3
J4	I ² S bus	I ² S bus connection for MCLK, BCLK, FSYNC, DIN, and DOUT
J5	External microphone input	To use an external microphone, remove R15 and R16
J6	Recording Diagnostics (EVAL. only)	Place a jumper on the J6 pin 1 and 2 or pin 2 and 3 for INxP diagnostic test
J7	I ² C	Connect SCL and SDA line directly for external I ² C control
J8	Power Supply Source	Place a jumper on pin 1 and 2 for 3.3V supply to be derived from VBAT. Place a jumper on pin 2 and 3 for 3.3V supply to be derived from AC-MB
J9	AC-MB (EVAL. only)	AC-MB connects here
J10	Recording Diagnostics (EVAL. only)	Place a jumper on the J10 pin 1 and 2 or pin 2 and 3 for INxM diagnostic test
J12	Diagnostics (EVAL. only)	Position 1 - INx Short to MICBIAS; Position 2 - INx Short to VBAT Position 3 - Inputs short together; Position 4- INx Short to GND
SW1	Diagnostics Trigger (EVAL. only)	Press switch to trigger J12 fault
SW2	Diagnostics Switch (EVAL. only)	Left position enables J6, right position enables J10

3.1.2 Configuring the Board

Either the onboard microphone (MK1) or an external microphone (J4) can be used with this design. Remove R15 and R16 from the board if using the external microphone. Figure 3-2 shows the schematic for the microphone input.

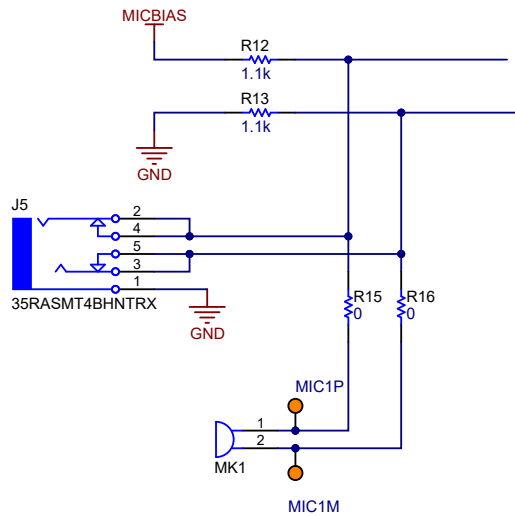

Figure 3-2. Microphone Input Configuration Schematic

3.2 Software Requirements

The TAx5xxx-Q1 GUI is used to send the I2C commands. The format of the scripts is:

```
R/W I2C Address Register Address Data
```

3.2.1 Firmware for Bench Tests

The following I2C commands show how to configure the TAC5312-Q1 for the signal path shown in Section 2.2.1.

```
##### Record DC-Couple Differential IN1-IN2 path, Playback LINEOUT #####
# Target Mode, TDM, 32-bit
# Primary ASI only, multiple of 48KHz Sampling
### Initialization and Record Path ###
w a0 00 00 # Set page 0
w a0 01 01 # Software Reset
w a0 02 09 # Wake up with AVDD > 2v and all VDDIO level
w a0 10 50 # Configure DOUT as Primary ASI (PASI) DOUT
w a0 11 80 # Enable PASI DIN
w a0 19 00 # 1 data input and 1 data output for PASI
w a0 1a 30 # PASI TDM, 32 bit format
w a0 1e 20 # PASI Ch1 on slot 0
w a0 1f 21 # PASI Ch2 on slot 1
w a0 00 01 # Set page 1
w a0 73 D0 # auto device, set MICBIAS = 9V
w a0 00 00 # Set page 0
w a0 50 04 # Ch1 diff input, fixed 33.3Kohm, 10Vrms, dc-coupled
w a0 55 04 # Ch2 diff input, fixed 33.3Kohm, 10Vrms, dc-coupled
### Playback Path ###
w a0 28 20 # PASI DIN Ch1 on TDM slot 0
w a0 29 21 # PASI DIN Ch2 on TDM slot 1
w a0 64 20 # Configure OUT1P/M as differential from DAC1
w a0 65 20 # Configure OUT1P LINEOUT 0dB audio band
w a0 66 20 # Configure OUT1M LINEOUT 0dB 2Vrms Differential
w a0 6b 20 # Configure OUT2P/M as differential from DAC2
w a0 6c 20 # Configure OUT2P LINEOUT 0dB audio band
w a0 6d 20 # Configure OUT2M LINEOUT 0dB 2Vrms Differential
#####

w a0 76 ff # Enable Input and Output channels
w a0 78 e0 # Power up ADC, DAC and MICBIAS
```

3.3 Test Setup

Equipment:

- Audio precision - APX555 and PSI
- Power supply - 4.5V to 18V, 3A
- 4Ω load
- Two multimeters

Bench test setup:

- PVDD = 14.4V
- 4Ω load

CISPR 25 radiated emissions test setup:

- PVDD = 14.4V
- 10W output across 4Ω load
- CISPR 25 class 5 radiated emissions setup

3.4 Test Results

3.4.1 Audio Performance

THD+N (Total Harmonic Distortion + Noise) is a measurement of how exceptional a sine wave is. The 1kHz sine wave is generated by the audio precision instrument and sent over I²S to the TAC5312-Q1. The audio precision then measures the THD+N of the analog signal across the 4Ω load. [Figure 3-3](#) shows the THD+N versus output power across the load.

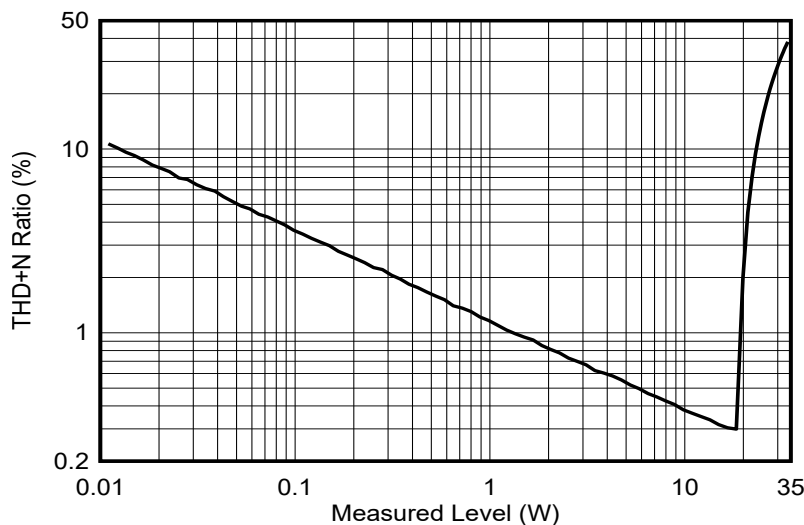

Figure 3-3. THD+N versus Output Power, 4Ω Load, PVDD = 14.4V, 1kHz Sine Wave

THD+N also varies with frequency. [Figure 3-4](#) shows the THD+N across frequency for three different power levels.

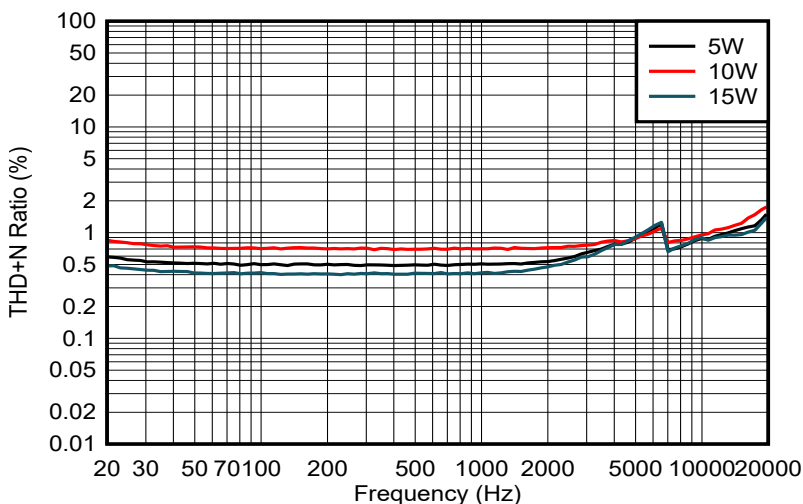

Figure 3-4. THD+N versus Frequency, 4Ω Load, PVDD = 14.4V

SWEEP	TRACE	COLOR	DATA	AXIS	COMMENT
1	1	Black	Anlr.THd+N Ratio	Left	5W
2	1	Red	Anlr.THd+N Ratio	Left	10W
3	1	Blue	Anlr.THd+N Ratio	Left	15W

3.4.2 Power Tests

Class-D amplifiers are designed for efficiency at higher output powers. The switching losses and device current consumption remain about the same regardless of output power which results in low efficiency at low output power and higher efficiency as the output power increases. Figure 3-5 shows the efficiency versus output power for the TIDA-060048.

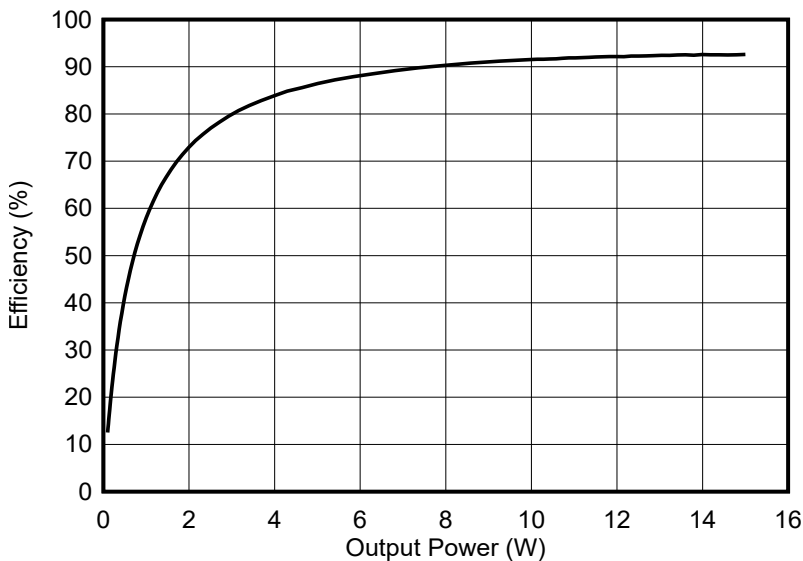

Figure 3-5. Efficiency versus Output Power, 4Ω Load, PVDD = 14.4V

At lower-input voltage levels, the output signal can clip at higher output powers. This affects the THD+N. Figure 3-6 shows the maximum output power versus the input voltage to achieve 1% or 10% THD+N. At over 10V, 8W of output power is achievable at less than 1% THD+N.

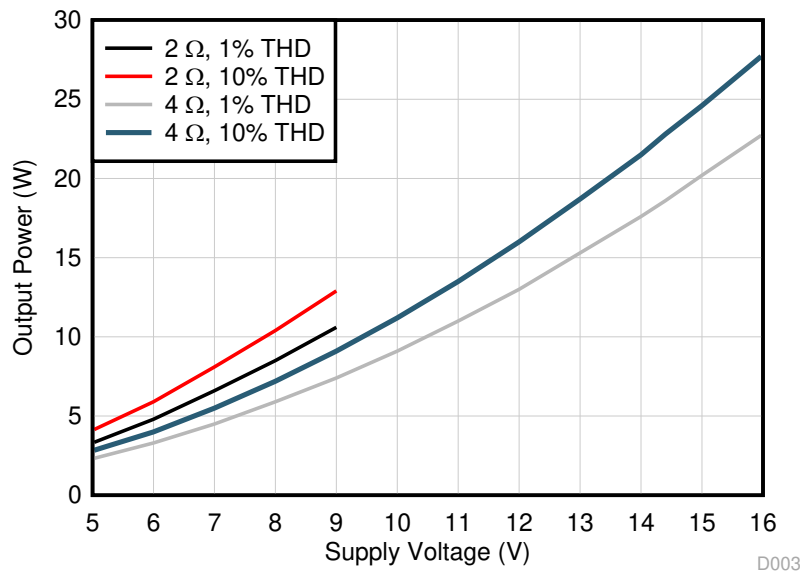

Figure 3-6. Maximum Output Power versus Input Voltage, 4Ω Load

3.4.3 EMI, EMC Test Results

This design is built and tested with the goal to pass CISPR 25 class 5 standards, the strictest of the CISPR classification standards. This CISPR EMI testing is done with a third-party facility and follows the international standard "to protect on-board receivers from disturbances produced by conducted and radiate emissions arising in a vehicle" (CISPR 25 Ed. 3.0 b: 2008, pg. 7) meaning that this particular reference design is tested to make sure that the design does not interfere with other equipment in the vehicle. As outlined in the standard, that radiated disturbances do not disrupt the broadcast and mobile service or band. For this particular reference design, broadcast standards are tested at *peak*, *quasi-peak*, and *average* ratings. For this test, a car battery or a 14.4V power supply is used in conjunction with short cables to test at optimized performance. Additionally, resistive load 4Ω to generate 1W is used. Figure 3-7 and Figure 3-8 show the setup and results of the CISPR 25 class 5 testing.



Figure 3-7. CISPR 25 Class 5 Test Setup for the TIDA-060048

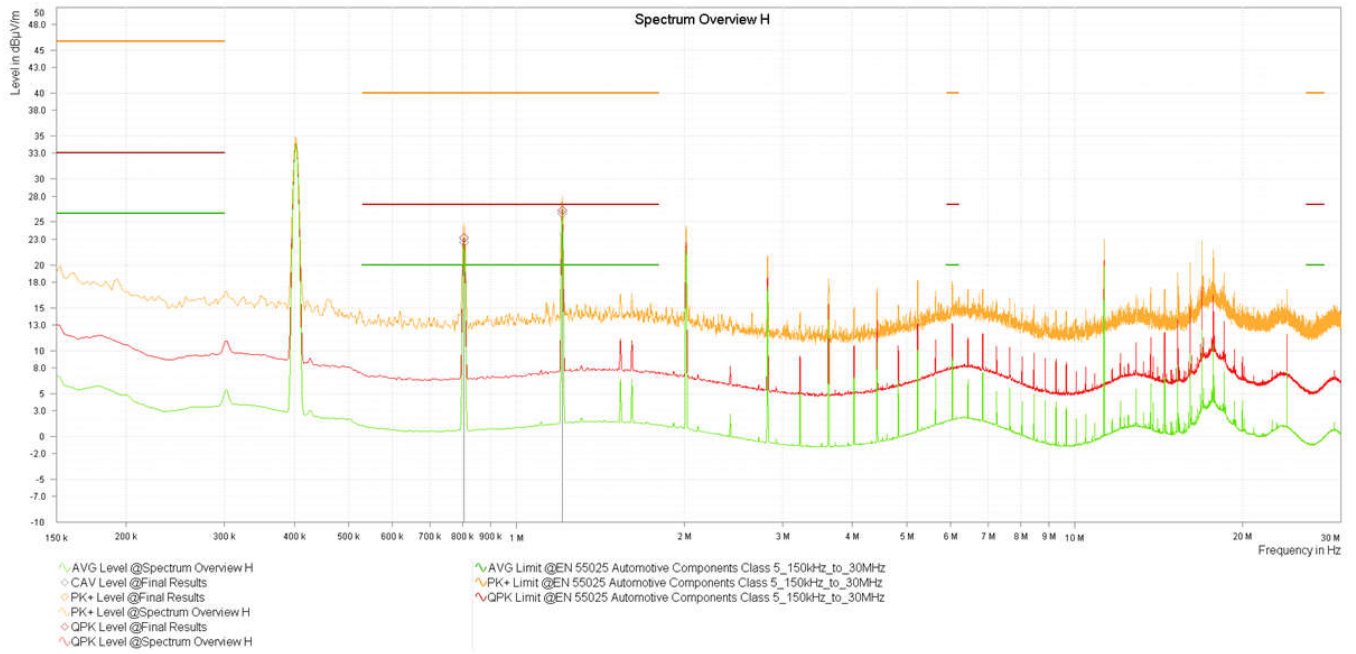

Figure 3-8. Radiated CISPR 25 Class 5 Testing Results for the TIDA-060048

4 Design and Documentation Support

4.1 Design Files

4.1.1 Schematics

To download the schematics, see the design files at [TIDA-060048](#).

4.1.2 Bill of Materials

To download the bill of materials (BOM), see the design files at [TIDA-060048](#).

4.1.3 PCB Layout Recommendations

There are three things to consider with the PCB: thermal dissipation, electromagnetic emissions, and signal integrity. All three of these considerations are especially critical when designing the layout around the TAS5441-Q1.

The TAS5441-Q1 can drive up to 22W of power through a load. While the TAS5411-Q1 is efficient, some losses dissipate as heat. The thermal pad on the bottom of the TAS5411-Q1 must be connected to a ground plane through vias directly below the thermal pad. Additionally, place a ground plane on the top layer with enough space around the TAS5411-Q1 to help dissipate the heat.

Electromagnetic emissions can occur because of the switching waveforms of the class-D amplifier output drivers. Reducing the area of these switching nodes and providing low inductance current paths reduces unwanted emissions. In particular, keep the traces from the outputs to the LC filter short, with a compact route back to ground.

Signal integrity is important in the path from the audio codec to the class-D amplifier inputs.

This is a differential analog signal. To protect the signal from unwanted noise, it is best if the traces from the audio codec can be kept short and for the traces to be routed directly above a ground plane without any digital signals crossing on the other layers.

4.1.3.1 Layout Prints

To download the layer plots, see the design files at [TIDA-060048](#).

4.1.4 Altium Project

To download the Altium Designer® project files, see the design files at [TIDA-060048](#).

4.1.5 Gerber Files

To download the Gerber files, see the design files at [TIDA-060048](#).

4.1.6 Assembly Drawings

To download the assembly drawings, see the design files at [TIDA-060048](#).

4.2 Documentation Support

1. Texas Instruments, [LC Filter Design Application Report](#)
2. Texas Instruments, [TLV320AIC3104 Programming Made Easy Application Report](#)

4.3 Support Resources

[TI E2E™ support forums](#) are an engineer's go-to source for fast, verified answers and design help — straight from the experts. Search existing answers or ask your own question to get the quick design help you need.

Linked content is provided "AS IS" by the respective contributors. They do not constitute TI specifications and do not necessarily reflect TI's views; see TI's [Terms of Use](#).

4.4 Trademarks

E2E™, PicoStar™, and TI E2E™ are trademarks of Texas Instruments.
Altium Designer® is a registered trademark of Altium LLC or its affiliated companies.
All trademarks are the property of their respective owners.

5 About the Author

DAVEON DOUGLAS is an Applications Engineer at Texas Instruments, where he is responsible for automotive audio data converters. Daveon earned his B.S in Electrical Engineering from Texas A&M University in College Station, TX.

IMPORTANT NOTICE AND DISCLAIMER

TI PROVIDES TECHNICAL AND RELIABILITY DATA (INCLUDING DATA SHEETS), DESIGN RESOURCES (INCLUDING REFERENCE DESIGNS), APPLICATION OR OTHER DESIGN ADVICE, WEB TOOLS, SAFETY INFORMATION, AND OTHER RESOURCES "AS IS" AND WITH ALL FAULTS, AND DISCLAIMS ALL WARRANTIES, EXPRESS AND IMPLIED, INCLUDING WITHOUT LIMITATION ANY IMPLIED WARRANTIES OF MERCHANTABILITY, FITNESS FOR A PARTICULAR PURPOSE OR NON-INFRINGEMENT OF THIRD PARTY INTELLECTUAL PROPERTY RIGHTS.

These resources are intended for skilled developers designing with TI products. You are solely responsible for (1) selecting the appropriate TI products for your application, (2) designing, validating and testing your application, and (3) ensuring your application meets applicable standards, and any other safety, security, regulatory or other requirements.

These resources are subject to change without notice. TI grants you permission to use these resources only for development of an application that uses the TI products described in the resource. Other reproduction and display of these resources is prohibited. No license is granted to any other TI intellectual property right or to any third party intellectual property right. TI disclaims responsibility for, and you will fully indemnify TI and its representatives against, any claims, damages, costs, losses, and liabilities arising out of your use of these resources.

TI's products are provided subject to [TI's Terms of Sale](#) or other applicable terms available either on [ti.com](https://www.ti.com) or provided in conjunction with such TI products. TI's provision of these resources does not expand or otherwise alter TI's applicable warranties or warranty disclaimers for TI products.

TI objects to and rejects any additional or different terms you may have proposed.

Mailing Address: Texas Instruments, Post Office Box 655303, Dallas, Texas 75265

Copyright © 2025, Texas Instruments Incorporated