

SmartRF05 Evaluation Board

User's Guide

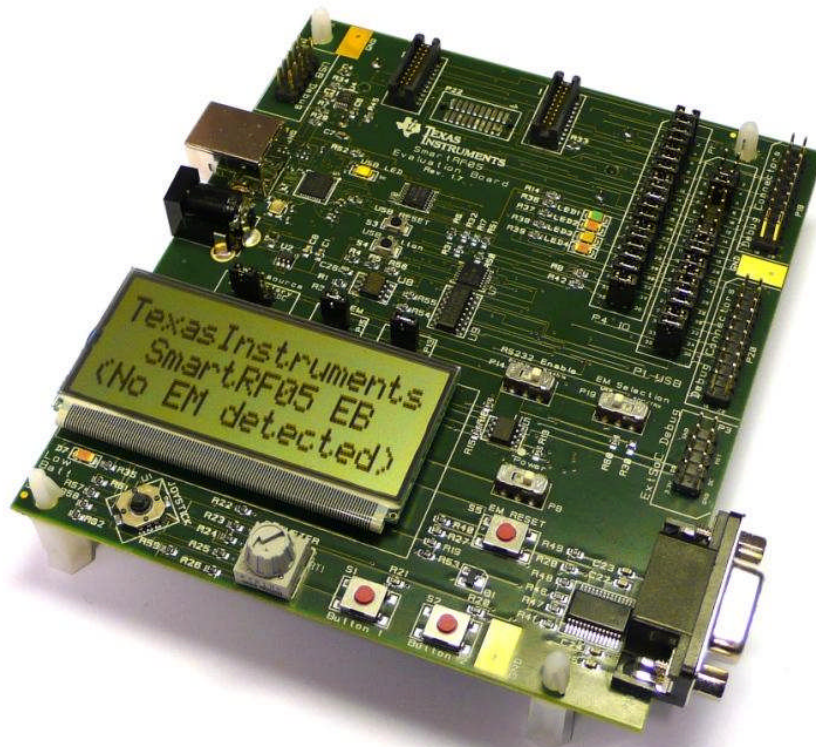

Table of Contents

1	INTRODUCTION.....	4
2	ABOUT THIS MANUAL.....	4
3	ACRONYMS AND ABBREVIATIONS.....	5
4	GETTING STARTED	6
4.1	SMARTRF STUDIO	6
4.2	INSTALLING SMARTRF STUDIO AND USB DRIVERS	6
5	USING THE SMARTRF05 EVALUATION BOARD	10
6	SMARTRF05 EVALUATION BOARD OVERVIEW.....	12
6.1	USB MCU	13
6.2	POWER SOURCES	13
6.2.1	<i>Battery power.....</i>	<i>13</i>
6.2.2	<i>DC Jack.....</i>	<i>13</i>
6.2.3	<i>USB power.....</i>	<i>14</i>
6.2.4	<i>Laboratory power supply.....</i>	<i>14</i>
6.3	UART RS232 INTERFACE	15
6.4	JOYSTICK	16
6.5	SERIAL FLASH	16
6.6	LCD	16
6.7	BUTTONS.....	17
6.8	LEDs.....	17
6.8.1	<i>General Purpose LEDs.....</i>	<i>17</i>
6.8.2	<i>Low Battery Indicator.....</i>	<i>17</i>
6.8.3	<i>USB LED.....</i>	<i>17</i>
6.9	BREAK-OUT HEADERS AND JUMPERS.....	18
6.10	EM CONNECTORS	19
6.11	PROBE CONNECTORS	20
6.12	CURRENT MEASUREMENT JUMPER	21
6.13	DEBUG CONNECTOR FOR EXTERNAL SoC.....	22
7	SMARTRF05EB REV 1.3.....	23
7.1	BOARD OVERVIEW	23
7.2	SOFTWARE CONSIDERATIONS	23
7.3	MODE SELECTION SWITCH.....	23
7.4	BREAKOUT HEADERS AND JUMPERS	24
7.5	USB MCU PIN OUT.....	26
8	SMARTRF05EB REV 1.7.....	27
8.1	BOARD OVERVIEW	27
8.2	CHANGES FROM REV 1.3.....	27
8.3	SOFTWARE CONSIDERATIONS	27
8.4	EM SELECTION SWITCH.....	28
8.5	BREAKOUT HEADERS AND JUMPERS.....	29
8.6	USB MCU PIN OUT.....	31
9	SMARTRF05EB REV 1.8.....	32
9.1	BOARD OVERVIEW	32
9.2	CHANGES FROM REV 1.7.....	32
9.3	SOFTWARE CONSIDERATIONS	32
10	UPDATING THE FIRMWARE.....	33
10.1	FORCED BOOT RECOVERY MODE.....	33
10.2	PROGRAMMING FIRMWARE USING AN EXTERNAL PROGRAMMER	34
11	FREQUENTLY ASKED QUESTIONS.....	35
12	REFERENCES.....	38
13	DOCUMENT HISTORY	38

List of Figures

Figure 1 - Connecting the SmartRF05EB for the first time (Windows XP).....	7
Figure 2 - Select automatic installation of software (Windows XP)	7
Figure 3 - Manually locate driver	8
Figure 4 - The driver installation is completed (Windows XP).....	8
Figure 5 - Properly installed SmartRF05EB software (Windows XP)	9
Figure 6 - SmartRF Studio with a CC2530EM connected to a SmartRF05EB.....	9
Figure 7 - SmartRF05EB with EM connected.....	10
Figure 8 - SmartRF05EB connected to a CC1111 USB Dongle	11
Figure 9 - SmartRF05EB architecture.....	12
Figure 10 - Main power selection jumper (P11) and power switch (P8)	13
Figure 11 - UART RS232 signals and jumpers	15
Figure 12 - General IO signal control flow.....	18
Figure 13 - V_EM Jumper	21
Figure 14 - Current measurement set-up.....	21
Figure 15 - SmartRF05EB External SoC Debug Connector	22
Figure 16 - Level converter for signals on the debug connector	22
Figure 17 - EB Mode Selection switch	23
Figure 18 - Basic signal flow on the evaluation board	24
Figure 19 - EM Selection Switch (P19).....	28
Figure 20 - Switch P19 effect on LED 1-4.....	28
Figure 21 - Switch P19 effect on Button 1.....	29
Figure 22 - Basic signal flow on the evaluation board	29
Figure 23 - USB controller debug connector	34

List of Tables

Table 1 - Voltage on JOY_LEVEL for different joystick positions (T=25°C, Vdd=3.0V)	16
Table 2 - EM connector P5 pin-out	19
Table 3 - EM Connector P6 pin-out	19
Table 4 - I/O connector P18 pin-out.....	20
Table 5 - I/O connector P20 pin-out.....	20
Table 6 - Jumpers on P1. Control signals available to the USB controller.....	24
Table 7 - Jumpers on P4. IO signals from all of the peripherals on the evaluation board.	25
Table 8 - USB MCU pin-out on SmartRF05EB rev 1.3.....	26
Table 9 - Jumpers on P1. Control signals available to the USB controller.....	30
Table 10 - Jumpers on P10. IO signals to peripherals on the evaluation board.....	30
Table 11 - USB MCU pin-out on SmartRF05EB rev 1.7	31

1 Introduction

The SmartRF05 Evaluation Board (SmartRF05EB or simply EB) is the motherboard in several development kits for Low Power RF devices from Texas Instruments. The board has a wide range of user interfaces, such as

- 3x16 character serial LCD
- Full speed USB 2.0 interface
- UART
- LEDs
- Serial Flash
- Potentiometer
- Joystick
- Buttons
- Breakout pins

The EB is the platform for the evaluation modules (EM) and can be connected to the PC via USB to control the EM.

2 About this manual

This manual contains reference information about the SmartRF05 Evaluation Board.

Chapter 4 will give a quick introduction to how to get started with the SmartRF05EB. In particular, it describes how to install SmartRF Studio to get the required USB drivers for the evaluation board. Chapter 5 briefly explains how the Evaluation Board can be used throughout a project's development cycle. Chapter 6 gives an overview of the various features and functionality provided by the board.

Chapter 7, 8 and 9 provide additional details about different versions of SmartRF05EB: revision 1.3, 1.7.x and 1.8.x, respectively. All of them are used in development kits¹, with revision 1.8 being used in all new builds. Chapter 10 describes how to update the firmware on the SmartRF05EB. A troubleshooting guide can be found in chapter 11.

Appendix A, B and C contain the schematics for the different versions of SmartRF05EB.

The PC tools SmartRF[®] Studio and SmartRF[®] Flash Programmer have their own user manuals.

See chapter 12 for a list of relevant documents and links.

¹ Revision 1.0, 1.1, 1.2, 1.4, 1.5 and 1.6 are internal versions only.

3 Acronyms and Abbreviations

CTS	Clear to Send
CW	Continuous Wave
DK	Development Kit
DUT	Device Under Test
EB	Evaluation Board
EM	Evaluation Module
HAL	Hardware Abstraction Layer
IC	Integrated Circuit
KB	Kilo Byte (1024 byte)
LCD	Liquid Crystal Display
LED	Light Emitting Diode
LPRF	Low Power RF
MCU	Micro Controller
RF	Radio Frequency
RTS	Request to Send
SoC	System on Chip
SPI	Serial Peripheral Interface
TI	Texas Instruments
TX	Transmit
UART	Universal Asynchronous Receive Transmit
USB	Universal Serial Bus

4 Getting started

Before plugging the SmartRF05EB into the PC via the USB cable, it is highly recommended to perform the steps described below first.

It is recommended to install SmartRF Studio before you connect the SmartRF05EB to the computer. The installation will include the USB drivers needed for PC applications to communicate with the board.

4.1 SmartRF Studio

SmartRF Studio is a PC application developed for configuration and evaluation of many of the RF-IC products from Texas Instruments. The application is designed for use with a SmartRF Evaluation Board, such as the SmartRF05EB, and runs on Microsoft Windows.

SmartRF Studio lets you explore and experiment with the RF-ICs as it gives full overview and access to the devices' registers to configure the radio and has a control interface for simple radio operation from the PC.

This means that SmartRF Studio will help radio system designers to easily evaluate the RF-IC at an early stage in the design process. It also offers a flexible code export function of radio register settings for software developers.

The latest version of SmartRF Studio can be downloaded from the Texas Instruments website (www.ti.com/smartrfstudio), where you will also find a complete user manual.

4.2 Installing SmartRF Studio and USB drivers

Before your PC can communicate with the SmartRF05EB over USB, you will need to install the USB drivers for the EB. The latest SmartRF Studio installer includes drivers for Windows.

A brief set of installation instructions for Microsoft Windows XP will be given here, but Windows 98, NT, 2000, Vista (32 bit) and 7 (32 bit) are also supported. Please consult the SmartRF Studio User Manual for further details or the troubleshooting section (chapter 11) if needed.

After you have downloaded SmartRF Studio from the web, extract the zip-file, run the installer file and follow the instructions. Select complete installation to include the SmartRF Studio program, the SmartRF Studio documentation and the necessary drivers needed to communicate with the SmartRF05EB.

You can now connect your SmartRF05EB to the computer with a USB cable and turn it on. A "Found new Hardware" dialog box will prompt you to locate the missing driver. See Figure 1. If you did a complete install of SmartRF Studio, the driver to use is already copied to your hard drive. In the dialog window below, select "No, not this time" and continue with "Next".



Figure 1 - Connecting the SmartRF05EB for the first time (Windows XP)

After clicking next, the window as shown in Figure 2 will appear. Select “Install the software automatically” to install the driver for the SmartRF05EB. Windows should automatically find the location of the driver to use.

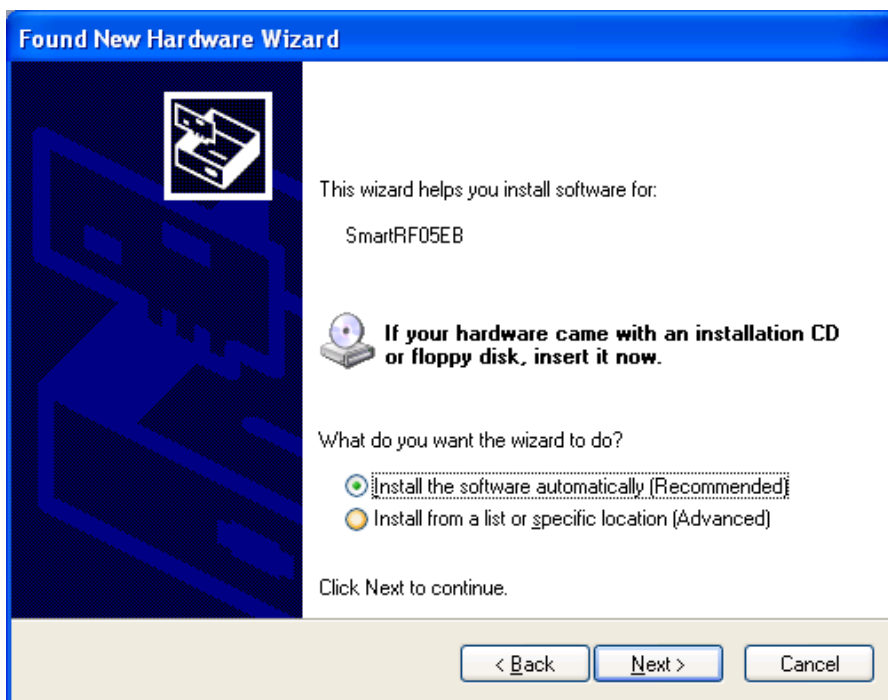

Figure 2 - Select automatic installation of software (Windows XP)

If Windows does not find the correct driver, you can manually specify where Windows should look for the driver. In the dialog shown in Figure 2, select “Install from a list of specific location”.

The drivers for the evaluation board are normally located in the directory C:\Program Files\Texas Instruments\Extras\Drivers, where C:\Program Files\Texas Instruments is the default root installation directory for SmartRF Studio.

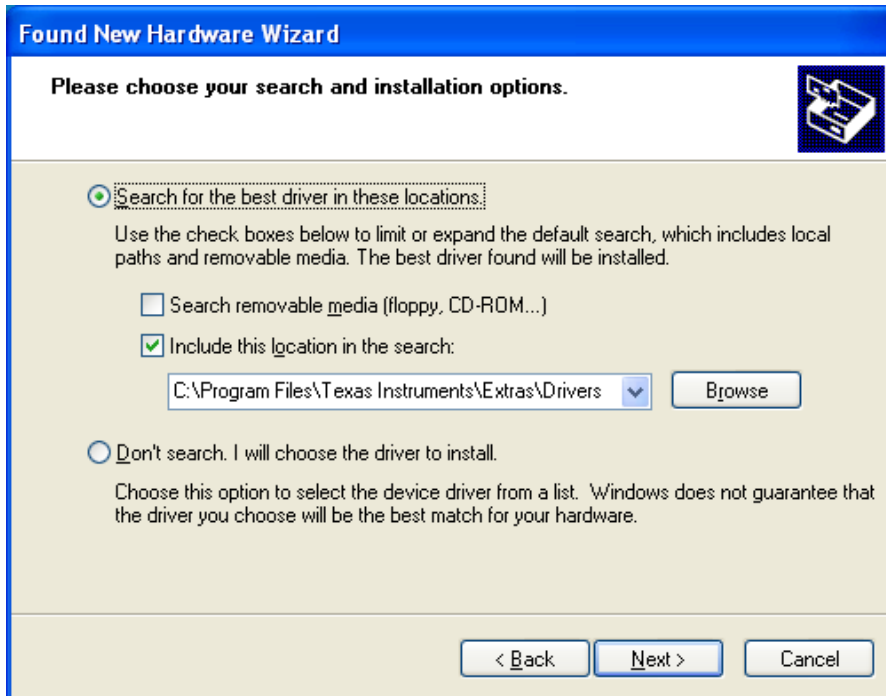

Figure 3 - Manually locate driver

The driver is now installed and the computer should be ready for use with SmartRF Studio.



Figure 4 - The driver installation is completed (Windows XP)

You can verify that the driver is properly installed by opening the Device Manager (Figure 5). When the EB is connected, the “Cebal controlled devices” list contains “SmartRF05EB”. If the board is listed as an unknown device, please follow the steps outlined in the SmartRF Studio User Manual.

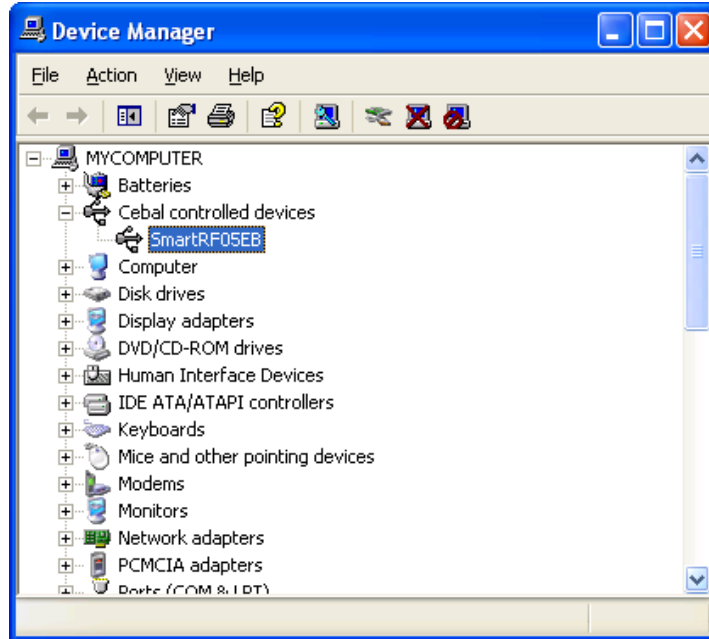

Figure 5 - Properly installed SmartRF05EB software (Windows XP)

When launching SmartRF Studio, the evaluation board should appear in the SmartRF05 DK tab (Figure 6). Double click on the device, and a new window opens – giving access to all of the registers on the chip as well as making it possible to perform various RF test.

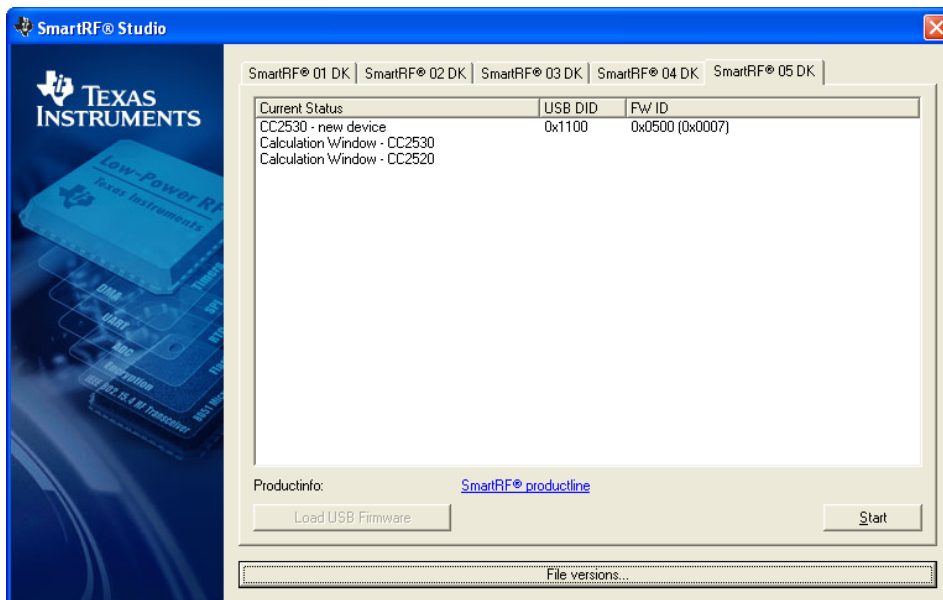

Figure 6 - SmartRF Studio with a CC2530EM connected to a SmartRF05EB

Please refer to the SmartRF Studio User Manual [2] for how to use Studio with an RF IC.

5 Using the SmartRF05 Evaluation Board

The SmartRF05EB is a flexible test and development platform that works together with RF Evaluation Modules from Texas Instruments.

An Evaluation Module is a small RF module with the RF chip, balun, matching filter, SMA antenna connector and IO connectors. The modules can be plugged into the SmartRF05EB, which lets the PC take direct control of the RF device on the EM over the USB interface.

Currently, SmartRF05EB supports:

- CC2520EM and variants with CC2590/CC2591
- CC2530EM and variants with CC2590/CC2591
- CC2430EM and variants with CC2590/CC2591
- CC2431EM
- CC2510EM
- CC1110EM
- CCMSP-EM430F2618
- CC1111 USB Dongle (connected through the debug header)
- CC2511 USB Dongle (connected through the debug header)
- CC2531 USB Dongle (connected through the debug header)

SmartRF05EB is included in the CC2520 and CC2530 development kits.

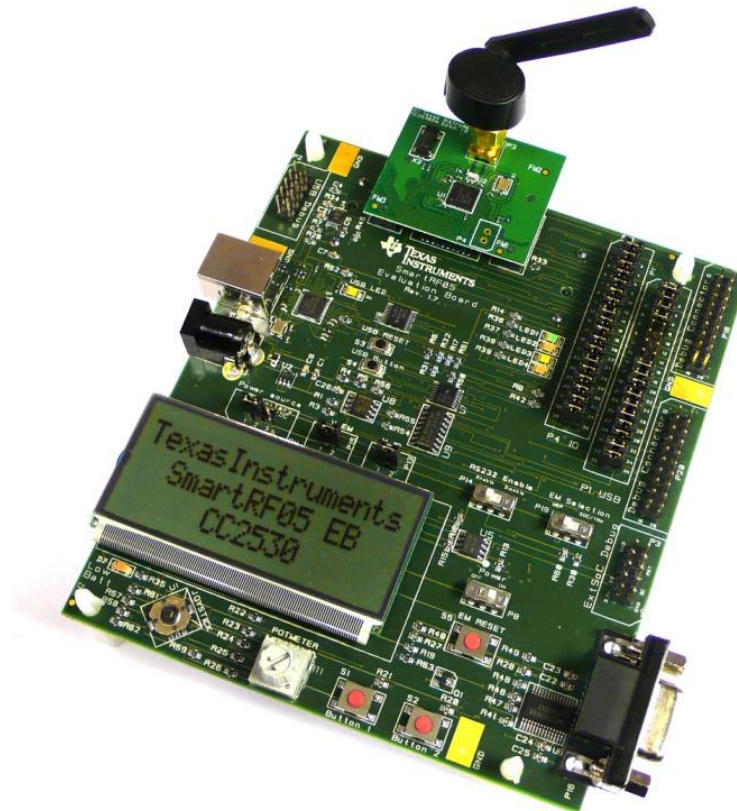

Figure 7 - SmartRF05EB with EM connected

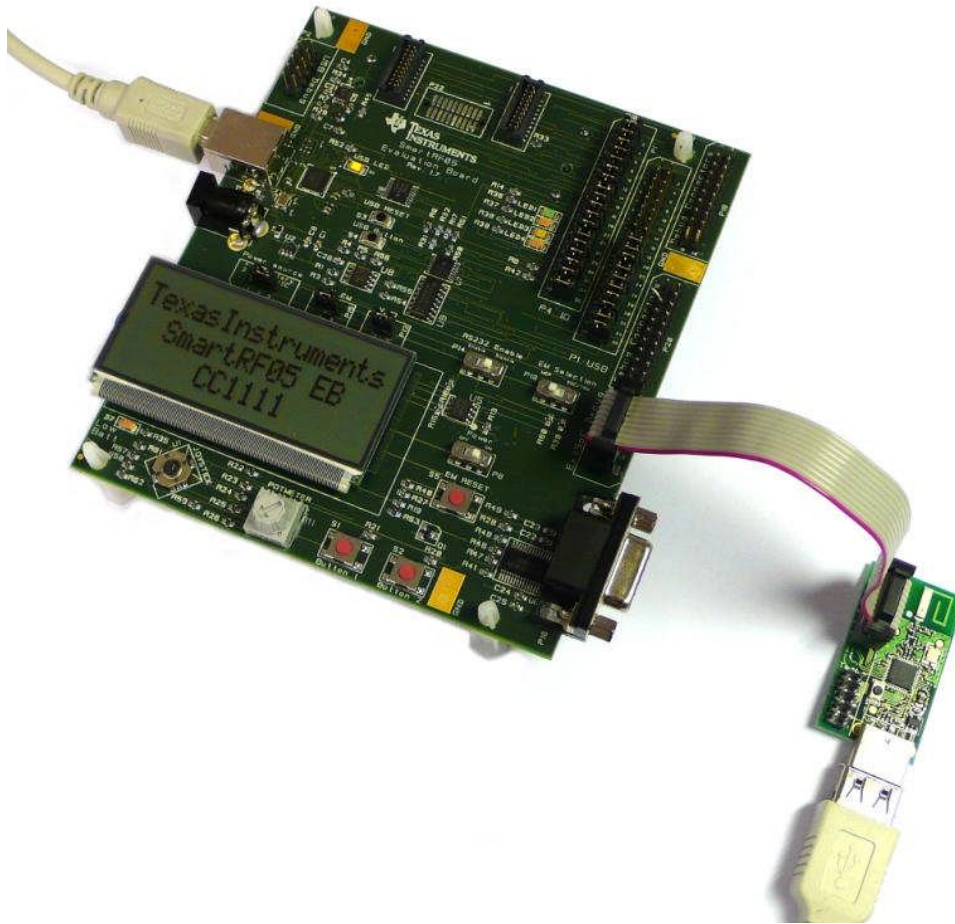

Figure 8 - SmartRF05EB connected to a CC1111 USB Dongle

The application on the PC that controls the EB+EM is SmartRF Studio. Studio can be used to perform several RF tests and measurements, like setting up a CW signal and send/receive packets.

The EB+EM can be of great help during the whole development cycle for a new RF product.

- Perform comparative studies. Compare results obtained with EB+EM with results from your own system.
- Perform basic functional tests of your own hardware by connecting the radio on your board to SmartRF05EB. SmartRF Studio can be used to exercise the radio.
- Verify your own software with known good RF hardware, by simply connecting your own microcontroller to an EM via the EB. Test the send function by transmitting packets from your SW and receive with another board using SmartRF Studio. Then transmit using SmartRF Studio and receive with your own software.
- For development kits with System on Chips, the evaluation boards make it possible to debug and program the chip without additional hardware. The kit also gives access to useful user interfaces for testing of the various peripherals and capabilities of the SoC.

The SmartRF05EB can also be used as a debugger interface to the SoCs from IAR Embedded Workbench for 8051.

6 SmartRF05 Evaluation Board Overview

SmartRF05EB acts as the motherboard in several development kits for Low Power RF ICs from Texas Instruments. The board has several user interfaces and connections to external interfaces allowing fast prototyping and testing of both software and hardware.

This chapter will give an overview of the general architecture of the board and describe the available IO. The following sub-sections will explain the IO in more detail. Pin-connections between the IO and EM can be found in section 6.10.

Note! There are several versions of SmartRF05EB. The main revisions are currently 1.3, 1.7.x and 1.8.x. Revisions 1.7.x and 1.8.x provide the same functionality, meaning that specific pin-out details and interconnections that apply to rev 1.7 **also apply to 1.8** (and newer). Differences between the boards will be discussed in chapter 7, 8 and 9.

Figure 9 shows the main components of the board and outlines the main communication buses.

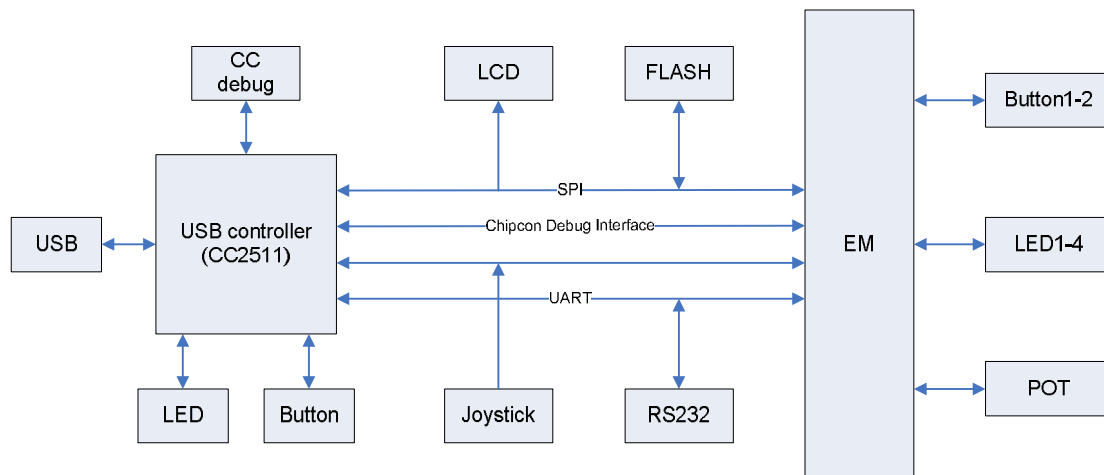

Figure 9 - SmartRF05EB architecture

The main component on the board is the USB controller. It communicates with the PC via USB and translates requests from various PC tools (e.g. SmartRF Studio, SmartRF Flash Programmer) to actions on the board.

The USB controller communicates with the evaluation module using SPI, UART and/or the Debug Interface (System-on-Chips only).

Note that not all of the peripherals on the board are accessible from the USB controller. It has access to the UART RS232 interface, LCD, one LED (D6), joystick and one button (USB button). I.e. it does not have access to the serial flash on the board.

The module connected to the EM connector has potentially access to all of the EB peripherals. It has full access to the LCD, serial flash, four LEDs, 2 buttons, joystick and UART RS232 interface.

Since many of the peripherals can be accessed from both the USB controller and the MCU EM, some I/O pins can potentially be driven by two different sources. The standard firmware running on the USB controller handles this by setting all shared I/O in three-state (high impedance) and thus avoids conflict.

6.1 USB MCU

The USB MCU is the CC2511F32 from Texas Instruments. Please see www.ti.com/cc2511 for detailed information about this controller.

The USB controller is programmed with a boot loader and the standard SmartRF05EB firmware when it is shipped from the factory.

When the boot loader starts running, it will check for a valid application in the flash of the CC2511. If the detection is successful, the application is started and the board can be operated normally. If no application is detected (e.g. blank flash or firmware upgrade failed) the USB LED (D6) will start blinking rapidly – indicating failure.

The standard firmware application is used to control the RF device on the attached Evaluation Module (EM) and to communicate with applications running on the PC via USB.

Note that the boot loader will allow programming of a new application over the USB interface. No additional hardware or programmers are needed. Both SmartRF Studio and SmartRF Flash Programmer can be used for this purpose. Please refer to chapter 10 for details.

6.2 Power Sources

There are four possible solutions for applying power to the SmartRF05EB. The power source can be selected using the power source selection jumper on header P11.

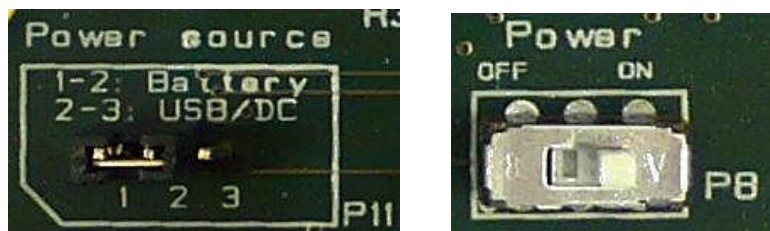

Figure 10 - Main power selection jumper (P11) and power switch (P8)

The main power supply switch (P8) turns off all power sources, unless an external power supply is connected to the board, overriding the onboard voltage regulators.

6.2.1 Battery power

The evaluation board includes a battery holder for two 1.5V AA batteries on the reverse side of the PCB: Normal AA batteries can be used and the on board regulator supplies 3.3 V to the board. The power source selection jumper should short circuit pin 1 and 2 of header P11. A LOW BATT LED on the board will be lit when the voltage on the board drops beneath 1.56 V. Note that this function is only active when powering the board using batteries. Also note that revision 1.8 of the SmartRF05EB does not have any LOW BATT LED.

Maximum current consumption is limited by the regulator to 100 mA on rev 1.3 and 1.7.x.
Maximum current consumption is limited by the regulator to 800 mA on rev 1.8.x.

6.2.2 DC Jack

SmartRF05EB has a connector with standard DC jack power connectors with a 2.5mm centre pin. The centre pin is used for the positive voltage. A 4-10 V DC power supply should be used. The onboard voltage regulator supplies approx 3.3 V to the board. The power source selection jumper should short circuit pin 2 and 3 of header P11.

Maximum current consumption is limited by the regulator to 250 mA on rev 1.3 and 1.7.x.
Maximum current consumption is limited by the regulator to 1500 mA on rev 1.8.x.

6.2.3 USB power

When SmartRF05EB is connected to a PC via a USB cable, it can draw power from the USB bus. The onboard voltage regulator supplies approx 3.3 V to the board. The power source selection jumper should short circuit pin 2 and 3 of header P11.

Maximum current consumption is limited by the regulator to 250 mA on rev 1.3 and 1.7.x.
Maximum current consumption is limited by the regulator to 1500(*) mA on rev 1.8.x.

(*) Note that most USB power sources are limited to 500 mA.

6.2.4 Laboratory power supply

When connecting a lab power supply, ground should be connected to any of the GND pads on the board. Remove the power source selection jumper and apply a voltage in the range from 2.7V to 3.6V to pin 2 on header P11. The main power switch will not have any effect in this case.

WARNING! Connecting the power source to P11 will bypass all voltage regulators on the board. There might be a risk of damaging the components on the board if the voltage on pin 2 on header P11 is lower than -0.3V or higher than 3.9V (maximum ratings for CC2511).

6.3 UART RS232 interface

The UART interface can be used by custom applications for communication with other devices. The interface uses a line driver device so that the port is compatible with RS232 signaling. The RS232 voltage converter can be disabled by changing the position of a jumper on EB revision 1.3 or by using a switch on EB revision ≥ 1.7 .

WARNING! On rev 1.3 and 1.7.x of the SmartRF05EB, the RS232 level converter will generate noise on Vcc and degrade the RF performance of any connected RF Evaluation Module. When running RF performance tests with SmartRF05EB, it is recommended to disable the RS232 level converter. This problem has been fixed on rev 1.8.x of the board.

The figure below gives a detailed overview of the UART signals and how they are connected to the different devices on the EB.

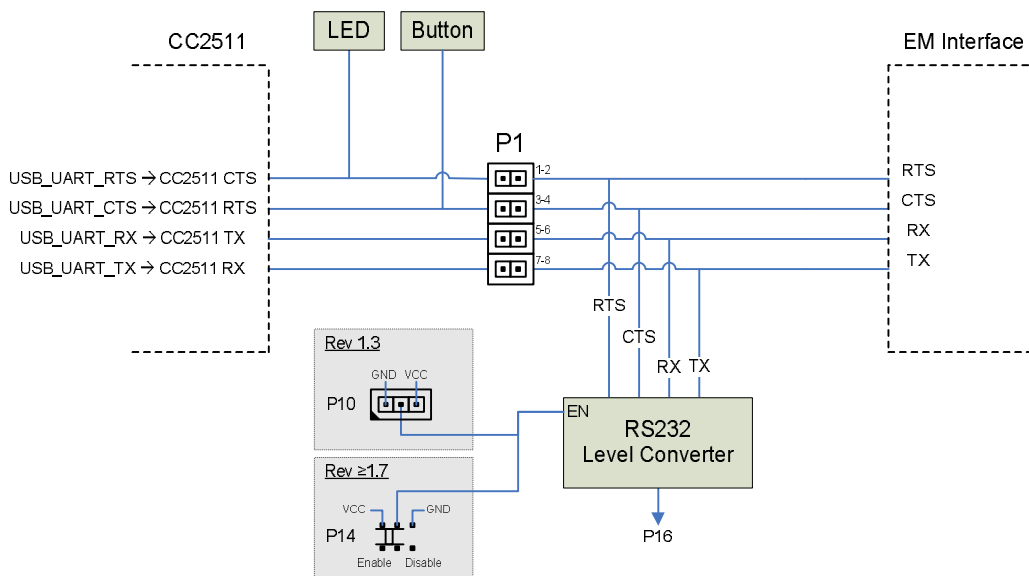

Figure 11 - UART RS232 signals and jumpers

As the figure shows, signals are crossed on the EB between the EM and the USB Controller and between the EM and the RS232 level converter/DE9 connector. Thus

- UART communication between a PC and an EB+EM requires a straight serial cable.
- UART communication between a PC and the USB Controller requires a null-modem cable (crossed).
- UART communication between the USB Controller and the microcontroller on the EM works without crossing any signals (RX connected to TX and vice versa).

Also note that the USB button and USB LED share the RTS and CTS signals going to the CC2511. To avoid any conflicts when the RTS/CTS UART flow control signal are used, disconnect jumpers 1-2 and 3-4 on P1. They are disconnected by default.

6.4 Joystick

The joystick detects five positions (centre, up, down, left, right) and one event (pushed). In case of moving the joystick from its centre position or pushing it, 5 discrete signals can be used to distinguish what happened. The discrete signals are routed the EM connectors. See section 0 for details.

Note that not all EMs have access to all signals on these connectors (depending on pin-count). In order to still have the possibility to use the joystick, an analogue joystick level signal was implemented in order to save the number of pins required on the MCU.

The two aggregated signals, JOY_MOVE and JOY_LEVEL, can be used to detect a joystick event. JOY_MOVE is high whenever the joystick is moved away from the centre position, including pushing. The other signal, JOY_LEVEL, is a voltage level signal that gives different values depending on the current position of the joystick. The table below shows these values. Note that the voltage levels are relative to the voltage on the board.

Joystick position	JOY_LEVEL (Volts)
Up	0.31
Down	1.16
Left	1.62
Right	1.81
Centre	2.12

Table 1 - Voltage on JOY_LEVEL for different joystick positions (T=25°C, Vdd=3.0V)

6.5 Serial Flash

The serial flash can be used as general purpose data and parameter storage, e.g. for temporary storage of an application image for Over the Air Download.

SmartRF05EB revision 1.3 has a M25PE10 flash device – a 128 kilobyte serial paged flash memory from Numonyx [5].

SmartRF05EB revision ≥ 1.7 has a M25PE20 flash device – a 256 kilobyte serial paged flash memory from Numonyx [5].

The serial flash can be accessed over the SPI bus from the EM, but not from the USB Controller, as the latter has not access to the flash chip select signal.

Note that SmartRF05EB will perform a controlled reset of the flash by toggling the flash reset signal after a power-on reset.

6.6 LCD

The LCD on SmartRF05EB is a 3x16 character display from Hitech Displays (HMC16311). The LCD is accessed over the SPI bus, using the dedicated LCD_CS signal for chip select. An addition control signal, LCD_MODE, is used to change the access types to the LCD. The reset signal is operated from the USB Controller – it will handle the proper power on reset sequence for the LCD.

Additional information about the LCD can be requested from Hitech Displays [6].

6.7 Buttons

There are five buttons on the evaluation board.

Button 1 and Button 2 are only connected to the EM, while the USB button is connected to the USB Controller.

The USB Reset button resets the USB controller. Note that the software on the USB controller will reset the EM during the startup, so pushing the USB reset button also resets the controller on the EM.

Pushing the EM reset button will pull the reset line on the EM low.

6.8 LEDs

6.8.1 General Purpose LEDs

The four LEDs D1, D2, D3 and D4 can only be controlled from the EM. The LEDs are active high.

6.8.2 Low Battery Indicator

The LOW BATT LED (D7) is turned on when the voltage from the batteries drops below approximately 1.56V. There is no LOW BATT LED on EB rev 1.8 or newer.

6.8.3 USB LED

LED D6 (USB LED) is controlled by the USB controller and is used to indicate the status of the board. The LED has several states:

- OFF**Power is turned off or the software on the USB controller is corrupt.
- ON**.....A transceiver has been detected and the standard firmware is running. The LED will also be on if an RF microcontroller has been detected and UART over USB is not enabled in the Evaluation Board firmware.
- SHORT BLINK**The LED might blink once during the power on sequence and then be turned off. An RF microcontroller has been detected and UART over USB is enabled in the Evaluation Board firmware.
- BLINKING – 1 Hz**The USB controller has entered the boot recovery mode. See chapter 10 for further details
- BLINKING – 10 Hz**The boot loader on the USB controller could not find a valid application to boot. Basic USB services are available and both SmartRF Studio and SmartRF Flash Programmer can be used to program an application in the USB Controller's flash. See chapter 10 for further details.

6.9 Break-out headers and jumpers

The signals from the EM connectors are connected to user interfaces or the CC2511 on the EB, but all of the signals are gated through either the “USB Jumper” header or “IO Jumper” header. Jumpers on these headers allows for fine tuned control of which signals are routed to what device and allows easy break-out of signals for debugging and development using proprietary peripherals.

All of the peripherals on the board and the USB controller can be isolated entirely from the EM, facilitating accurate power consumption measurements.

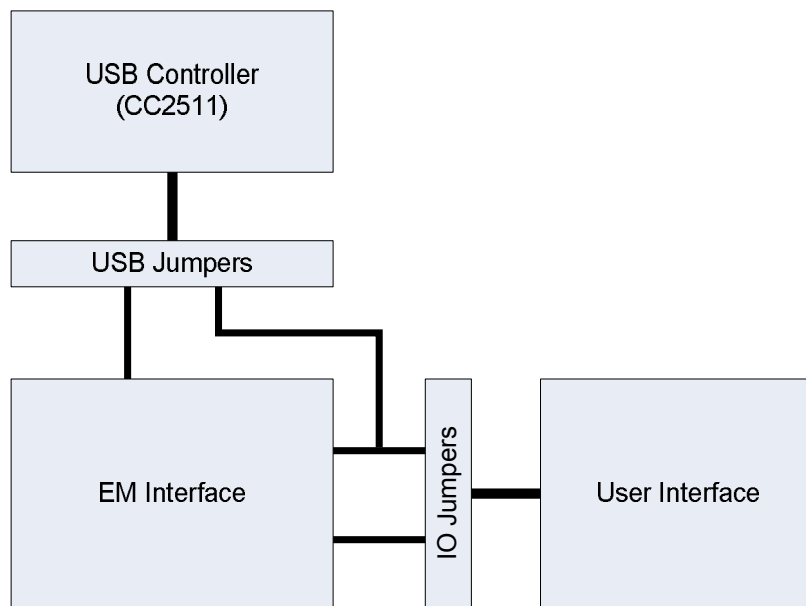

Figure 12 - General IO signal control flow

The pin out of the break out connectors is slightly different on revision 1.3 and revision ≥ 1.7 of SmartRF05EB. Please refer to the respective chapters later in this document.

6.10 EM connectors

The EM connectors are used for connecting an EM to the SmartRF05EB. The connectors P5 and P6 are used as the main interface. The pin-out for these connectors is shown below.

The modifications introduced in revision ≥ 1.7 of the board are marked with **bold** letters.

Note that some of the signals are shared, e.g. EM_BUTTON1/EM_LED4_SOC. This means that the signal is connected to different IO on the board, in this case both Button 1 and LED4. Pressing Button 1 will affect the state of LED4. Similarly, if a SoC is toggling LED4, it cannot read from Button 1 at the same time.

Signal name		Pin	Pin	Signal name	
Rev 1.3	Rev ≥ 1.7			Rev ≥ 1.7	Rev 1.3
GND	GND	1	2	EM_JOYSTICK_DN	EM_JOYSTICK_DN
EM_UART_CTS	EM_UART_CTS	3	4	EM_FLASH_CS	EM_FLASH_CS
EM_BUTTON1	EM_BUTTON1/ EM_LED4_SOC	5	6	EM_LED1	EM_LED1
EM_UART_RX	EM_UART_RX	7	8	EM_JOYSTICK_RT	EM_JOYSTICK_RT
EM_UART_TX	EM_UART_TX	9	10	EM_DBG_DD	EM_DBG_DD
EM_LCD_MODE	EM_LCD_MODE	11	12	EM_DBG_DC	EM_DBG_DC
EM_LCD_FLASH_RESET	EM_LED2_SOC	13	14	EM_CS/ EM_LED3_SOC	EM_CS
EM_JOY_LEVEL	EM_JOY_LEVEL	15	16	EM_SCLK	EM_SCLK
EM_POT_R	EM_POT_R	17	18	EM_MOSI	EM_MOSI
GND	GND	19	20	EM_MISO	EM_MISO

Table 2 - EM connector P5 pin-out

Signal name		Pin	Pin	Signal name	
Rev 1.3	Rev ≥ 1.7			Rev ≥ 1.7	Rev 1.3
EM_JOYSTICK_PUSH	EM_JOYSTICK_PUSH	1	2	GND	NC
NC	NC	3	4	EM_LED2_MSP	EM_LED2_MSP
EM_PWR_SNOOZE	EM_PWR_SNOOZE	5	6	EM_LED3_MSP	EM_LED3_MSP
VCC	VCC	7	8	EM_LED4_MSP	EM_LED4_MSP
VCC	VCC	9	10	NC	NC
EM_JOYSTICK_UP	EM_JOYSTICK_UP	11	12	EM_USB2	NC
EM_JOYSTICK_LT	EM_JOYSTICK_LT	13	14	EM_USB1	NC
EM_RESET	EM_RESET	15	16	EM_BUTTON2	EM_BUTTON2
EM_LCD_CS	EM_LCD_CS	17	18	EM_UART_RTS	EM_UART_RTS
EM_JOY_MOVE	EM_JOY_MOVE	19	20	EM_DBG_DIR	NC

Table 3 - EM Connector P6 pin-out

The LCD and Flash reset signal is no longer available from the EM on EB revision ≥ 1.7 . The controller of the motherboard will ensure controlled reset of these devices after a power on reset by toggling the reset pin.

6.11 Probe Connectors

The probe connectors (P18 and P20) bring out all the signals from the EM connectors. These connectors are compatible with Agilent logic analyzer probes. The connectors allow easy access to I/O signals and to connect prototyping boards.

The modifications introduced in revision ≥ 1.7 of the board are marked with **bold** letters.

Signal name		Pin	Pin	Signal name	
Rev 1.3	Rev ≥ 1.7			Rev ≥ 1.7	Rev 1.3
NC	NC	1	2	NC	NC
NC	EM_USB1	3	4	EM_FLASH_CS	EM_FLASH_CS
EM_BUTTON1	EM_USB2	5	6	EM_LED2_SOC	EM_LED1
EM_UART_RX	EM_BUTTON1/ EM_LED4_SOC	7	8	EM_DBG_DD	EM_JOYSTICK_RT
EM_UART_TX	EM_UART_RX	9	10	EM_DBG_DC	EM_DBG_DD
EM_LCD_MODE	EM_UART_TX	11	12	EM_MISO	EM_DBG_DC
EM_LCD_FLASH_RESET	EM_UART_CTS	13	14	EM_CS/ EM_LED3_SOC	EM_CS
EM_JOY_LEVEL	EM_UART_RTS	15	16	EM_SCLK	EM_SCLK
EM_POT_R	EM_POT_R	17	18	EM_MOSI	EM_MOSI
EM_MISO	EM_DBG_DD_DIR	19	20	GND	GND

Table 4 - I/O connector P18 pin-out

Signal name		Pin	Pin	Signal name	
Rev 1.3	Rev ≥ 1.7			Rev ≥ 1.7	Rev 1.3
NC	NC	1	2	NC	NC
NC	VCC	3	4	EM_LED1	EM_LED2
PS_PWR_SNOOZE	PS_PWR_SNOOZE	5	6	EM_LED2_MSP	EM_LED3
EM_VCC	EM_JOYSTICK_RT	7	8	EM_LED3_MSP	EM_LED4
NC	EM_JOYSTICK_DN	9	10	EM_LED4_MSP	EM_JOYSTICK_PUSH
EM_JOYSTICK_UP	EM_JOYSTICK_UP	11	12	EM_LCD_MODE	EM_JOYSTICK_DN
EM_JOYSTICK_LT	EM_JOYSTICK_LT	13	14	EM_RESET	EM_UART_CTS
EM_RESET	EM_JOYSTICK_PUSH	15	16	EM_BUTTON2	EM_BUTTON2
EM_LCD_CS	EM_JOY_LEVEL	17	18	EM_LCD_CS	EM_UART_RTS
EM_JOY_MOVE	EM_JOY_MOVE	19	20	GND	GND

Table 5 - I/O connector P20 pin-out

6.12 Current Measurement Jumper

Jumper P15, also called V_EM, has been added to the board to simplify current consumption measurements. By removing the jumper, an Ampere Meter can easily be connected to the board to perform current consumption measurements. Similarly, a separate, regulated power supply for the EM can be connected.

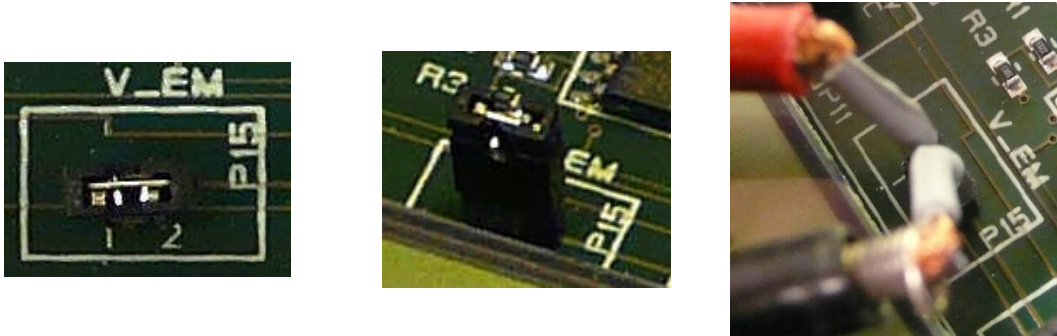

Figure 13 - V_EM Jumper

If the EM is powered by a different source than the rest of the board, the same voltage should be used on the EM as on the EB. The digital signals between the EB and the EM are not isolated from each other, and different voltage levels can cause excessive current consumption or erroneous interaction between the EB and the EM.

In order to get accurate power consumption measurements, selected jumpers on the “IO” and “USB” break-out headers should be removed to isolate the device under test from the peripherals.



Figure 14 - Current measurement set-up

6.13 Debug Connector for External SoC

SmartRF05EB is equipped with a debug connector (P3 ExtSoC Debug, and P4 on rev 1.8.x) that allows debugging and programming of an external RF microcontroller from Texas Instruments. The pin-out of the connector is depicted below.

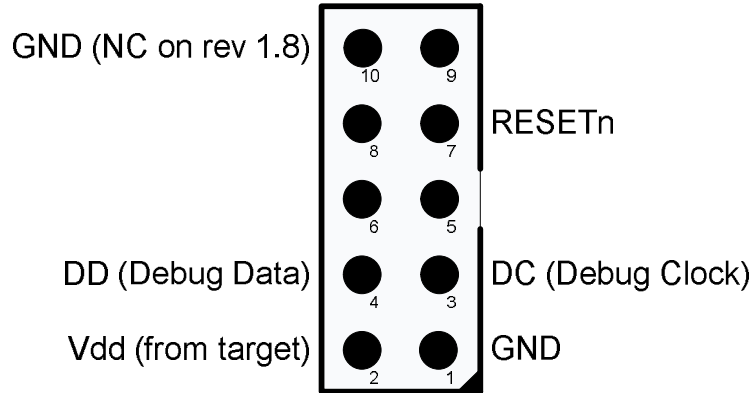

Figure 15 - SmartRF05EB External SoC Debug Connector

By connecting a target RF board correctly to the EB, the EB will operate as a debug adapter for the RF SoC. For instance, it will be possible to debug and single-step code using the IAR EW8051 IDE and it is possible to control the RF SoC using SmartRF Studio.

There is a level converter between the bus on the target and internally on the EB. In order to operate correctly, the level converter needs the voltage on the target provided as a reference voltage for correct level shifting of signals. With the level converter, the target can operate at a completely different voltage level than the 3.3V on the SmartRF05EB.

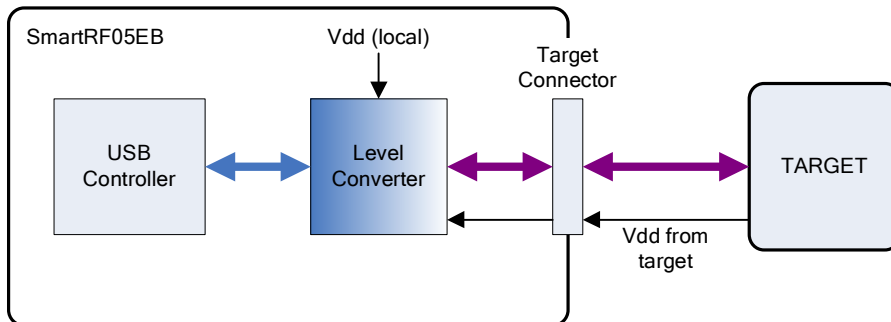
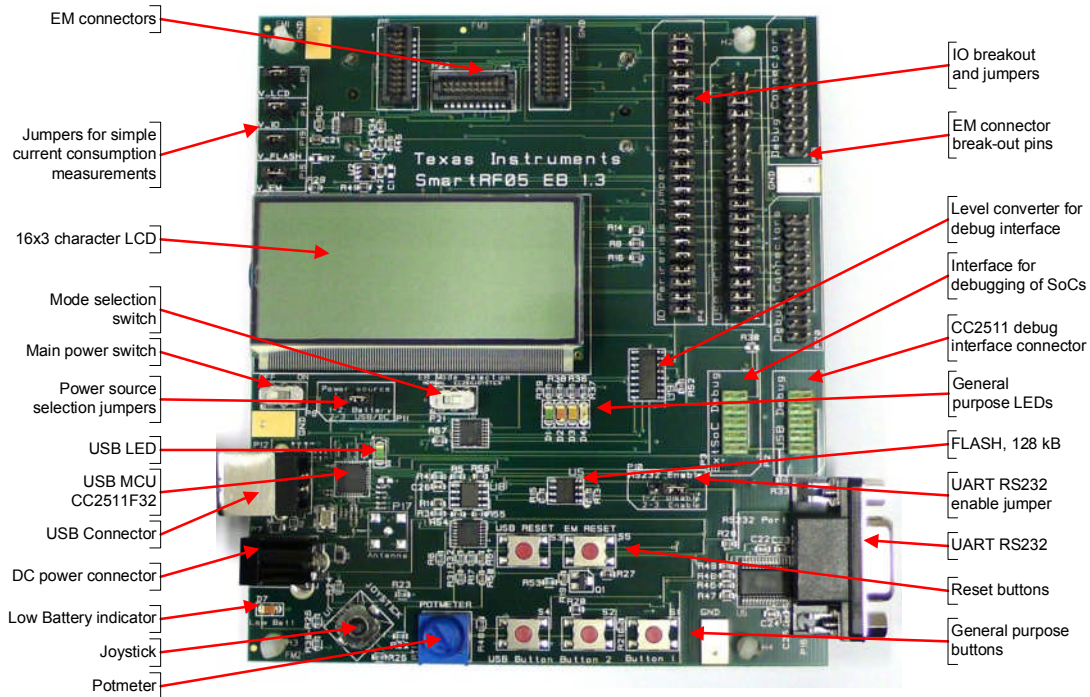

Figure 16 - Level converter for signals on the debug connector

Minimum operating voltage on target: 1.2 Volt
 Maximum operating voltage on target: 3.6 Volt

7 SmartRF05EB rev 1.3

7.1 Board overview



7.2 Software considerations

When running the TIMAC and/or Z-Stack on a CC2530EM plugged into SmartRF05EB revision 1.3, it is necessary to set the compile option `#define HAL_BOARD_CC2530EB_REV13`.

The default HAL configuration uses `#define HAL_BOARD_CC2530EB_REV17`.

7.3 Mode selection switch

SmartRF05EB has a mode selection switch (P21) that allows two configurations of the evaluation board.

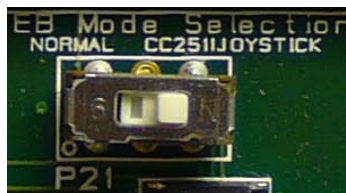

Figure 17 - EB Mode Selection switch

In the NORMAL position, the evaluation board is in a normal operating mode, enabling support in hardware both for debugging of an external SoC and a special packet sniffer interface for the CC2520EM.

The CC2511JOYSTICK position is primarily intended for the special case where a custom application is running on the CC2511 using the joystick (JOY_LEVEL and JOY_MOVE) for user input. In this position, neither the external debug interface nor the hardware support for CC2520 packet sniffer will work.

The switch is by default placed in the NORMAL position.

7.4 Breakout headers and jumpers

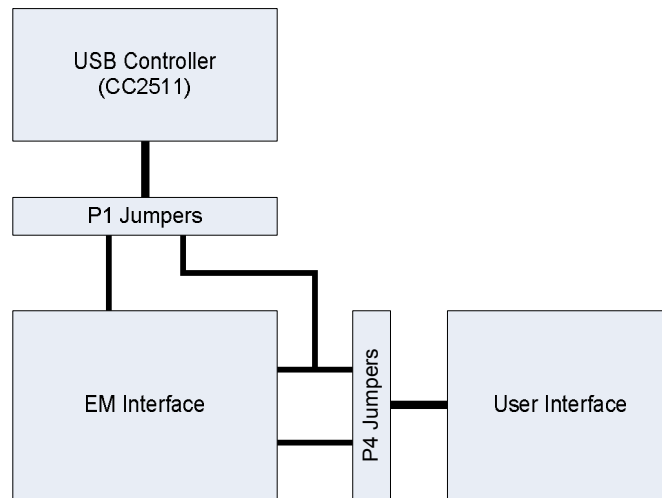

Figure 18 - Basic signal flow on the evaluation board

Pins	Function	Description	Default mounted
1-2	UART_RTS	Ready to send (UART flow control)	No
3-4	UART_CTS	Clear to send (UART flow control)	No
5-6	UART_RX	Received data – connected to TX on CC2511	Yes
7-8	UART_TX	Transmitted data – connected to RX on CC2511	Yes
9-10	SNIFF_DATA	Sniff interface – (special feature for CC2520)	No
11-12	SNIFF_CLK	Sniff interface – (special feature for CC2520)	No
13-14	SNIFF_MISO	Sniff interface – (special feature for CC2520)	No
15-16	SNIFF_SFD	Sniff interface – (special feature for CC2520)	No
17-18	DBG_DC	Debug Clock signal (debug interface for system-on-chips)	Yes
19-20	DBG_DD	Debug Data signal (debug interface for system-on-chips)	Yes
21-22	CS	Chip select for SPI device on EM module	Yes
23-24	SCLK	SPI clock	Yes
25-26	MOSI	SPI data – master output, slave input	Yes
27-28	MISO	SPI data – master input, slave output	Yes
29-30	LCD_CS	Chip select for LCD	Yes
31-32	LCD_MODE	LCD control signal	Yes
33-34	LCD_FLASH_RESET	Common reset signal for serial Flash and LCD	Yes
35-36	JOY_LEVEL	Voltage level from joystick, indicating position	Yes
37-38	JOY_MOVE	Positive edge when the joystick is moved	Yes

Table 6 - Jumpers on P1. Control signals available to the USB controller.

Pins	Function	Description	Default mounted
1-2	JOY_MOVE	See P1, 37-38	Yes
3-4	JOY_LEVEL	See P1, 35-36	Yes
5-6	LCD_FLASH_RESET	See P1, 33-34	Yes
7-8	LCD_MODE	See P1, 31-32	Yes
9-10	LCD_CS	See P1, 29-30	Yes
11-12	MISO	See P1, 27-28. Connected to LCD and serial Flash.	Yes
13-14	MOSI	See P1, 25-26. Connected to LCD and serial Flash.	Yes
15-16	SCLK	See P1, 23-24. Connected to LCD and serial Flash.	Yes
17-18	FLASH_CS	Chip select for serial flash	Yes
19-20	BUTTON1	Button 1. Low when pushed.	Yes
21-22	BUTTON2	Button 2. Low when pushed.	Yes
23-24	LED1	Control signal for LED D1. Set high to turn LED on.	Yes
25-26	LED2	Control signal for LED D2. Set high to turn LED on.	Yes
27-28	LED3	Control signal for LED D3. Set high to turn LED on.	Yes
29-30	LED4	Control signal for LED D4. Set high to turn LED on.	Yes
31-32	JOYSTICK_UP	Signal goes high when joystick is moved up.	Yes
33-34	JOYSTICK_DN	Signal goes high when joystick is moved down.	Yes
35-36	JOYSTICK_LT	Signal goes high when joystick is moved left.	Yes
37-38	JOYSTICK_RT	Signal goes high when joystick is moved right.	Yes
39-40	JOYSTICK_PUSH	Signal goes high when joystick is pushed.	Yes
41-42	POT_R	Voltage level from potentiometer. Value between 0 and VCC.	Yes
43-44	EM_RESET	Reset signal to EM.	Yes

Table 7 - Jumpers on P4. IO signals from all of the peripherals on the evaluation board.

7.5 USB MCU pin out

The following table shows how the USB Controller's (CC2511) pins are connected to the different functionalities on the EB.

CC2511 Pin	Function on the Evaluation Board	Description
P0.0	SPI_SELECT /JOY_LEVEL	Function depending on switch P21: NORMAL: When SPI_SELECT is set LOW, it enables a special CC2520 sniffer interface (for test and diagnostic purposes). CC2511JOY: Joystick level is an analog value that can be decoded to find the actual position of the joystick (centre, up, left, right or down)
P0.1	USB_EM_RESET	Signal used to reset the EM board
P0.2	USB_CS	SPI Chip select for device on EM board
P0.3	USB_SCLK	SPI Clock
P0.4	USB_MOSI	SPI MOSI (master out, slave in)
P0.5	USB_MISO	SPI MISO (master in, slave out)
P1.0	USB_IFC_CTRL	Enables the USB interface when it is set high. Set either by the boot loader or the firmware.
P1.1	USB_DBG_DC	Debug clock – used when CC2511 communicates with another LPRF Soc via the debug interface.
P1.2	USB_UART_RTS/USB_LED	Dual function: UART Ready To Send and output signal for control of LED D6.
P1.3	USB_UART_CTS/USB_BUTTON	Dual function: UART Clear To Send and input signal for USB button event.
P1.4	USB_UART_TX	UART TX
P1.5	USB_UART_RX	UART RX
P1.6	DGB_DD_DIR /JOY_MOVE	Function depending on switch P21: NORMAL: The debug data direction signal controls the signal flow on the level converter for the external debug interface. CC2511JOY: Joystick move signal input. Set high on any joystick event (pushed, moved up, left, right or down)
P1.7	USB_DBG_DD	Debug data – used when CC2511 communicates with another LPRF SoC via the debug interface.
P2.0	USB_LCD_FLASH_RESET	Resets both the serial flash and the LCD on the board when it is set low.
P2.1	CC2511 DBG DD	CC2511 debug interface
P2.2	CC2511 DBG DC	CC2511 debug interface
P2.3	LCD_MODE	Selects operating mode of the LCD
P2.4	LCD_CS	SPI Chip select signal for the LCD

Table 8 - USB MCU pin-out on SmartRF05EB rev 1.3

8 SmartRF05EB rev 1.7

8.1 Board overview

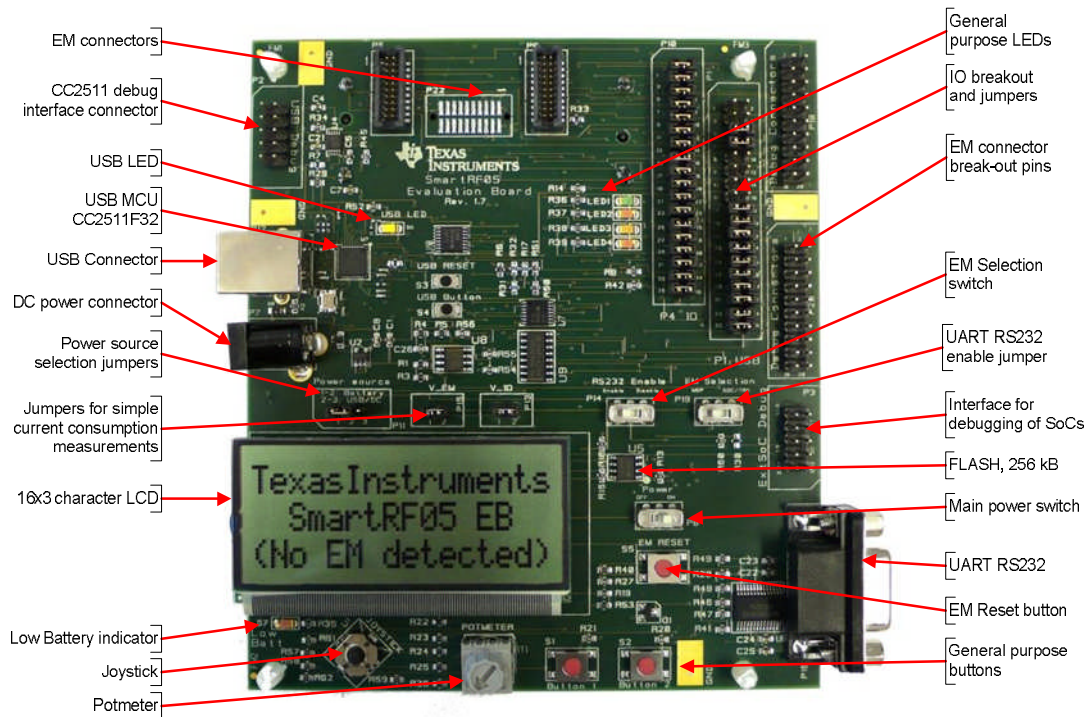

8.2 Changes from rev 1.3

- The layout of the board has changed.
- Improved routing of power from the VCC_EM jumper, enabling more accurate current consumption measurements
- The on-board regulated voltage is now 3.3V, regardless of power source (USB, DC or batteries). Previously, the voltage was 3.3V with batteries and 3.0V with USB or DC.
- The size of the on-board SPI Flash is 256 kB (was 128 kB).
- Added a mode switch that changes the board from "MSP" mode to "SoC" mode. Chapter 8.3 has more details. Short summary:
 - In MSP mode, the board works exactly as revision 1.3
 - In SoC mode, it is now possible to access all four LEDs from the SoC
 - The polarity of the Button 1 signal can be changed

8.3 Software considerations

Note the new polarity of Button 1 and that all 4 LEDs on the Board can now be accessed from the SoC. The signal from the SoC that controls LED 2 was used to reset the LCD on rev 1.3 of the board.

When running the TIMAC and/or Z-Stack on a CC2530EM plugged into SmartRF05EB revision 1.7, the `#define HAL_BOARD_CC2530EB_REV17` is used in the default HAL configuration. Therefore the user does not have to do anything.

8.4 EM Selection Switch

The EM selection switch that was introduced on SmartRF05EB controls a multiplexer on the board that allows either a connected RF SoC EM or an MSP430 add-on board to access all four LEDs on the evaluation board. The limitation was caused by the particular pin-out on the RF evaluation modules that needed to be backwards compatible with other boards and test equipment.

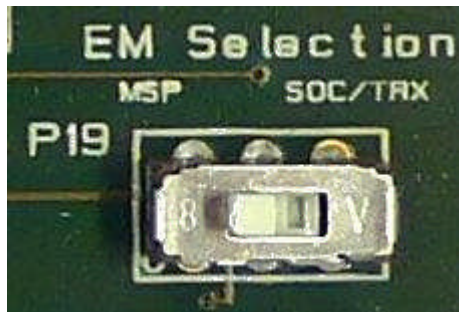

Figure 19 - EM Selection Switch (P19)

The switch will both affect the operation of the LEDs and Button 1.

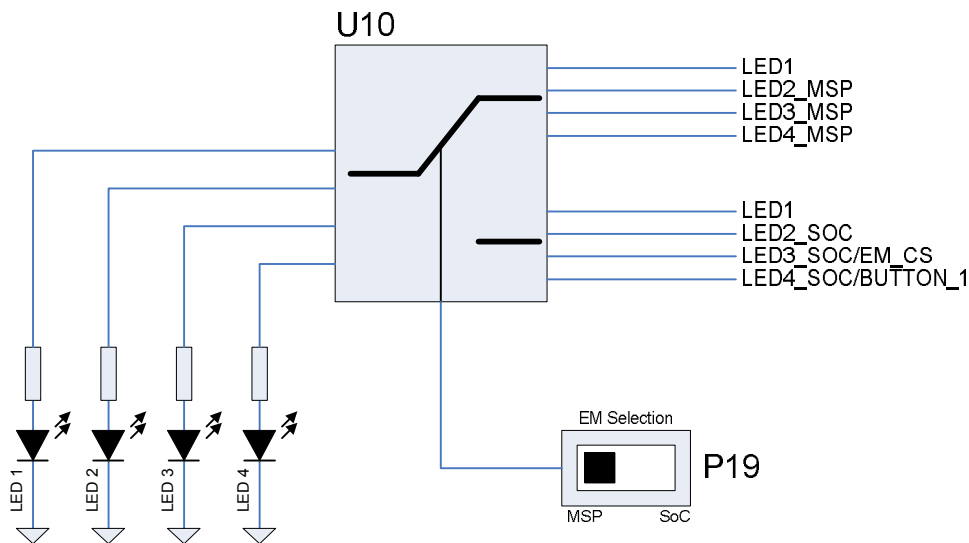

Figure 20 - Switch P19 effect on LED 1-4

Due to lack of pins, some of the signals are shared.

When LED3 is used by the SoC, the chip select signal to the EM will also be affected. In most cases, this will not be a problem, since the SoC does not, by default, implement an SPI slave.

When LED4 is used by the SoC, the signal from Button 1 might interfere. In short, Button 1 and LED 4 can not be used simultaneously by the SoC.

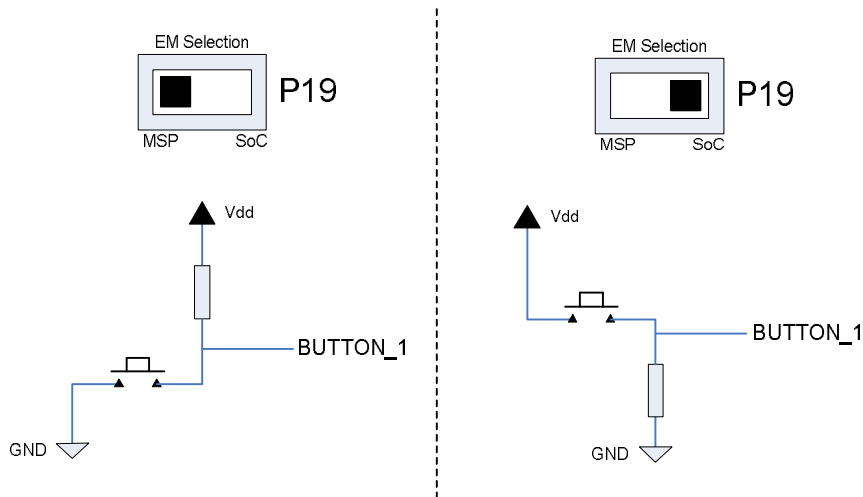

Figure 21 - Switch P19 effect on Button 1

The EM Selection switch will change the polarity of button number 1.

In the MSP position, the button is active low, i.e. low voltage when the button is pressed. In the inactive position, the level is high (signal is pulled up by a 10k Ohm resistor). This is also the operating mode of the button on revision 1.3 of the SmartRF05EB.

In the SoC position, the button is active high, i.e. high voltage when the button is pressed. In the inactive position, the level is low (signal is pulled down by a 10k Ohm resistor).

Note that it is possible to use this feature to determine the position of switch P19 (assuming no one is pressing the button).

8.5 Breakout headers and jumpers

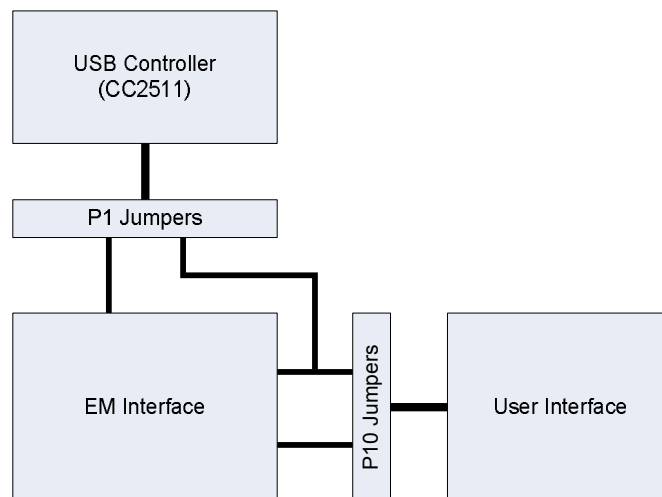

Figure 22 - Basic signal flow on the evaluation board

Pins	Function	Description	Default mounted
1-2	UART_RTS	Ready to send (UART flow control)	No
3-4	UART_CTS	Clear to send (UART flow control)	No
5-6	UART_RX	Received data – connected to TX on CC2511	Yes
7-8	UART_TX	Transmitted data – connected to RX on CC2511	Yes
9-10	NC	Not used	No
11-12	NC	Not used	No
13-14	NC	Not used	No
15-16	NC	Not used	No
17-18	DBG_DD_DIR	Debug Data signal direction control	Yes
19-20	DBG_DC	Debug Clock signal (debug interface for system-on-chips)	Yes
21-22	DBG_DD	Debug Data signal (debug interface for system-on-chips)	Yes
23-24	CS	Chip select for SPI device on EM module	Yes
25-26	MISO	SPI data – master input, slave output	Yes
27-28	MOSI	SPI data – master output, slave input	Yes
29-30	SCLK	SPI clock	Yes
31-32	LCD_CS	Chip select for LCD	Yes
33-34	LCD_MODE	LCD control signal	Yes
35-36	JOY_MOVE	Positive edge when the joystick is moved	Yes

Table 9 - Jumpers on P1. Control signals available to the USB controller.

Pins	Function	Description	Default mounted
1-2	JOY_MOVE	Positive edge when the joystick is moved	Yes
3-4	JOY_LEVEL	Voltage level from joystick, indicating current position	Yes
5-6	LCD_MODE	LCD control signal	Yes
7-8	LCD_CS	Chip select for LCD	Yes
9-10	MISO	SPI bus (data). Connected to LCD and serial Flash	Yes
11-12	MOSI	SPI bus (data). Connected to LCD and serial Flash	Yes
13-14	SCLK	SPI bus (clock). Connected to LCD and serial Flash	Yes
15-16	FLASH_CS	Chip select for serial flash	Yes
17-18	BUTTON1/LED4_SOC	Shared signal between Button 1 and LED4	Yes
19-20	BUTTON2	Button 2	Yes
21-22	LED1	Control signal for LED1. Set high to turn LED on	Yes
23-24	LED2_MSP	Control signal for LED2. Set high to turn LED on	Yes
25-26	LED2_SOC	Control signal for LED2. Set high to turn LED on	Yes
27-28	LED3_MSP	Control signal for LED3. Set high to turn LED on	Yes
29-30	LED3_SOC	Control signal for LED3. Set high to turn LED on	Yes
31-32	LED4_MSP	Control signal for LED4. Set high to turn LED on	Yes
33-34	POT_R	Voltage level from potentiometer.	Yes
35-36	EM_RESET	Reset signal to EM.	Yes

Table 10 - Jumpers on P10. IO signals to peripherals on the evaluation board.

8.6 USB MCU pin out

The following table shows how the USB Controller's (CC2511) pins are connected to the different functionalities on the EB.

Pin	Function	Description
P0.0	JOY_MOVE	Joystick move signal input. Set high on any joystick event (pushed, moved up, left, right or down)
P0.1	USB_EM_RESET	Signal used to reset the EM board
P0.2	USB_CS	SPI Chip select for device on EM board
P0.3	USB_SCLK	SPI Clock
P0.4	USB_MOSI	SPI MOSI (master out, slave in)
P0.5	USB_MISO	SPI MISO (master in, slave out)
P1.0	USB_IFC_CTRL	Enables the USB interface when it is set high. Set either by the boot loader or the firmware.
P1.1	USB_DBG_DC	Debug clock – used when CC2511 communicates with another LPRF SoC via the debug interface.
P1.2	USB_UART_RTS/USB_LED	Dual function: UART Ready To Send and output signal for control of LED D6.
P1.3	USB_UART_CTS/USB_BUTTON	Dual function: UART Clear To Send and input signal for USB button event.
P1.4	USB_UART_TX	UART TX
P1.5	USB_UART_RX	UART RX
P1.6	DGB_DD_DIR	The debug data direction signal controls the signal flow on the level converter for the external debug interface.
P1.7	USB_DBG_DD	Debug data – used when CC2511 communicates with another LPRF SoC via the debug interface.
P2.0	USB_IO_RESET	Resets the serial flash and the LCD on the board when it is set low.
P2.1	CC2511 DBG DD	CC2511 debug interface
P2.2	CC2511 DBG DC	CC2511 debug interface
P2.3	LCD_MODE	Selects operating mode of the LCD
P2.4	LCD_CS	SPI Chip select signal for the LCD

Table 11 - USB MCU pin-out on SmartRF05EB rev 1.7

9 SmartRF05EB rev 1.8

9.1 Board Overview

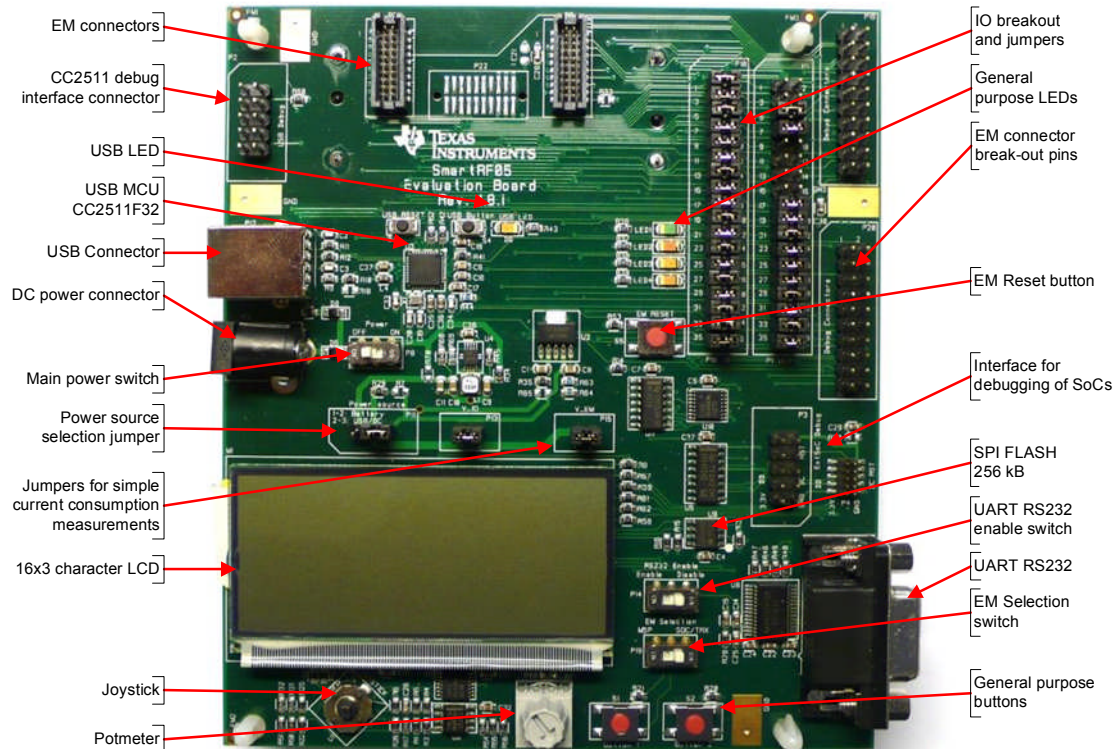

9.2 Changes from rev 1.7

Revision 1.8.x of SmartRF05EB is an improved version of rev 1.7. There are NO differences in functionality, so software working on rev 1.7 will also work for rev 1.8.

- The layout of the board has changed. In particular, the ON/OFF switch has been moved closer to the USB/DC Jack power sources.
- New on-board DC/DC regulators and improved decoupling, providing a very stable power source for the RF evaluation modules.
- The new battery regulator does not have a “power good” output signal, so the “Low Batt” LED has been removed.
- Improved routing of power and ground for optimized RF performance.

9.3 Software considerations

See chapter 8.3.

10 Updating the firmware

Updating of firmware is done automatically by SmartRF Studio if it detects an old and/or incompatible firmware version on the controller. SmartRF Studio and SmartRF Flash Programmer also allow manual programming of the firmware. Please refer to the respective user's guides for detailed instructions. A simple step-by-step guide is provided below

There should not be any EM boards connected to the 05EB while updating the firmware on the EB.

1. Turn off the evaluation board (EB)
2. Disconnect the evaluation module (EM)
3. Plug in the USB cable and turn the board on
4. The SmartRF05EB should appear as an entry in the list under the SmartRF05DK tab in SmartRF Studio. Single click the entry in the list to highlight the board.
5. Click the "Load USB firmware" button. A file select dialog window will pop up.
6. Select the following file: <installation_dir>\extras\srf05eb\srf05eb_fwid0500.hex
7. The firmware will be upgraded. This might take several seconds.
8. The EB will re-appear as an entry in the SmartRF Studio window.
9. If you get the warning about failed upgrade, it might actually happen that the firmware was upgraded as expected - it is only the timing of the response from the board that confuses Studio sometimes. It would not be a problem to retry the firmware update. If it fails completely, use the SmartRF Flash Programmer.

10.1 Forced boot recovery mode

If, for some reason, the firmware update fails and the evaluation board appears to be dead, there is a way to force the board to only run the boot loader and stop all further execution. No attempts will be made to start the firmware.

The approach is slightly different on revision 1.3 and revision ≥ 1.7 of the boards.

On revision 1.3: Turn power off. Place the EB Mode Selection switch (P21) in the CC2511JOYSTICK position and move the joystick in any direction other than the centre position. While the joystick is moved away from the centre position, turn power on.

On revision ≥ 1.7 : Turn power off. Short-circuit pin 17 and 19 on header P18 with a jumper. Next, turn the potentiometer clockwise until it stops. Turn power on.

When the board is turned on, the firmware is not started and the boot loader will have control of the board. The LED D6 will be blinking with a 1 second interval, indicating that the boot loader is running. You can use this method to check whether you have a working boot loader or not.

When the boot loader is running, the only functionality that is offered from SmartRF Studio and SmartRF Flash Programmer is to load a new version of the standard firmware.

10.2 Programming firmware using an external programmer

It is also possible to update both the firmware and boot loader on the board by using the debug interface of the USB Controller.

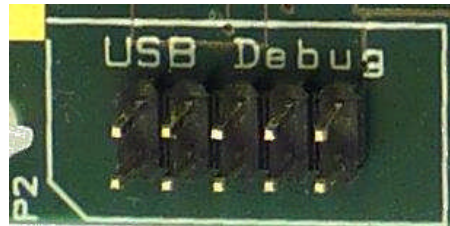

Figure 23 - USB controller debug connector

The USB controller is the CC2511 from Texas Instruments, so it is possible to use SmartRF Flash Programmer and another evaluation board (either SmartRF04EB or SmartRF05EB) to program the chip. Connect a 10-pin flat cable to the “Ext SoC Debug” plug (P3) on the PROGRAMMER and to the “USB Debug” plug (P2) on the board that is being programmed (DUT). Turn on power on both boards – first on the DUT, then on the PROGRAMMER. The PROGRAMMER should now detect the CC2511 on the DUT. The flash programmer application can be operated as described in the Flash Programmer User Manual.

When programming the firmware on the EB with an external programmer, it is possible to overwrite the preprogrammed bootloader on the USB controller. The Flash Programmer User Manual describes how this can be avoided.

11 Frequently Asked Questions

Q1 How do I check the firmware revision on the Evaluation Board?

A1 You can use SmartRF Flash Programmer to check re firmware revision. Connect the EB board (without any evaluation modules attached) to a PC and launch the Flash Programmer application. Select the “EB application (USB)” tab. The SmartRF board should be listed, showing relevant information about the firmware running on the board. In the example below, the firmware revision is 0009.

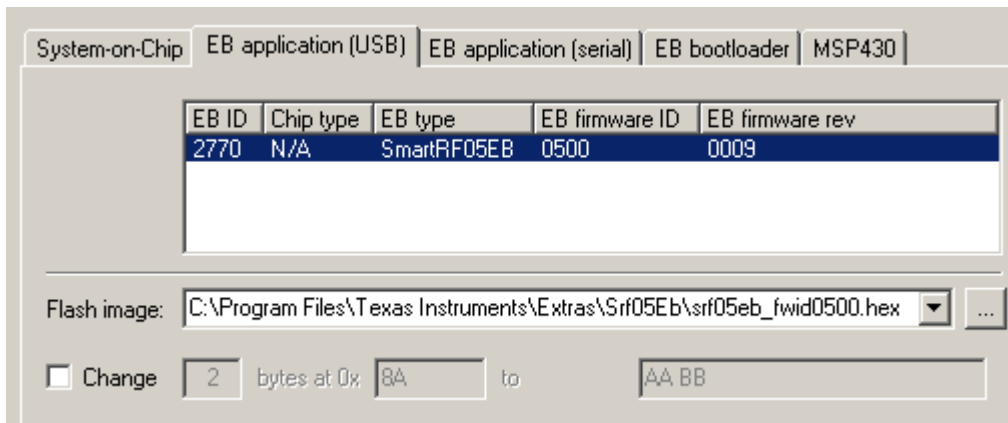

The same application can be used to update the firmware to the latest revision. The most up to date revision is bundled with the Flash Programmer, and the firmware image is normally located at C:\Program Files\Texas Instruments\Extras\Srf05Eb. See the Flash Programmer User Manual for further information.

Q2 Installation of drivers for the evaluation board fails. Help!

A2 Instead of selecting automatic installation of drivers, select “Install from a list or specific location (Advanced)”. You will see the following window.

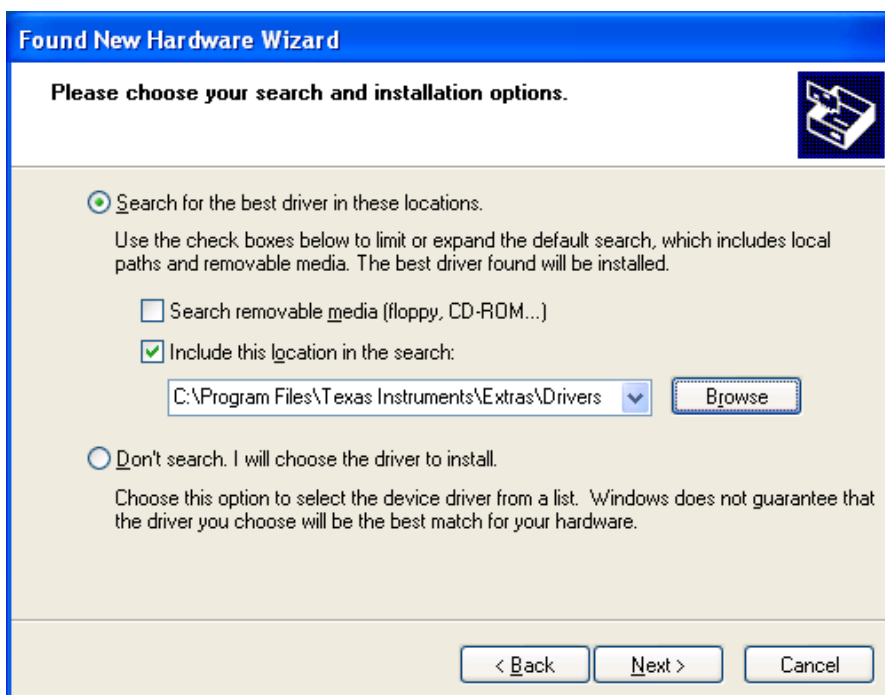

The drivers for the evaluation board are normally located in the directory C:\Program Files\Texas Instruments\Extras\Drivers, where C:\Program Files\Texas Instruments is the default root installation directory for SmartRF Studio. The path may be different if you have chosen a different installation directory for SmartRF Studio.

If the above fails, select “Don’t search. I will choose the driver to install.” A new window will open, asking for a location of where drivers can be found. Locate the srf05eb.inf file and select that driver for installation.

Q3 Nothing happens when I power up the evaluation board. Why?

A3 Make sure that all jumpers on the IO headers on the evaluation board are set in default position.

Q4 When powering up the evaluation board, the LED D6 starts blinking. Why?

A4 If the blink frequency is 1 time per second, the boot loader has entered a forced boot recovery mode (set during programming of the device). Power off the system and turn it back on to start the application.

If the blinking is more rapid (10 times per second) the boot loader could not find a valid application in flash. Use SmartRF Studio or SmartRF Flash Programmer to program a new firmware on the board. See also section 6.8.3.

Q5 How can I measure the current consumption of the radio on the EM?

A5 The easiest way to measure current consumption of the chip in various modes is to connect the EM directly to the SmartRF05EB and disconnect everything on the board that consumes power by removing all jumpers on the breakout headers. Make sure the RS232 level converter is disabled. Connect the ampere meter between the two pins on P15 (V_EM).

In order to allow SmartRF Studio to control the device on the EM, connect the respective jumpers for the debug interface for SoCs or the four SPI signals for transceivers. Use SmartRF Studio to set the radio in different modes (RX, TX, etc.).

Q6 I already have a SmartRF05EB revision 1.3 and I have written a lot of software for that board. Now, I get revision 1.7 in new development kits. Do I need to rewrite all of my software?

A6 No, you do not need to rewrite your software. Just make sure that the EM Selection switch is in position “MSP”, and the board will work just like the old revision. A few things to note:

The reset signal going to the LCD from the EM module has been removed. It is not necessary to perform a hard reset of the LCD – this is done by the controller on the EB board during a power-on reset.

Official software releases from Texas Instruments will, by default, support revision 1.7 of the board. This will not have any impact on software for the CC2520DK, since the operating mode of 05EB rev 1.7 in “MSP” mode is identical to the normal operating mode of 05EB rev 1.3.

Q7 I already have a SmartRF05EB revision 1.7 and I have written a lot of software for that board. Now, I get revision 1.8 in new development kits. Do I need to rewrite all of my software?

A7 No, there's no need to change any software.

Q8 I have a SmartRF04EB. Can I use the SmartRF05EB instead?

A8 It depends. SmartRF05EB will only support a subset of the devices supported by SmartRF04EB. All SoCs will be supported, but you will need to port the software to the new platform. No transceivers will be supported.

By "supported", we mean supported by SmartRF Studio. The EB will detect all of the devices and the EM modules will not be damaged if connected to the SmartRF05EB – but certain functions in SmartRF Studio will not work.

Q9 Will SmartRF05EB replace SmartRF04EB in your existing development kits?

A9 No

12 References

- [1] SmartRF Studio
www.ti.com/smartrfstudio
- [2] SmartRF Studio User Manual
www.ti.com/lit/pdf/swru070
- [3] Flash Programmer
<http://focus.ti.com/docs/toolsw/folders/print/flash-programmer.html>
- [4] Flash Programmer User Manual
www.ti.com/lit/pdf/swru069
- [5] Numonyx M25PE
www.numonyx.com/documents/datasheets/M25PE20_10.pdf
- [6] Hitech Displays
www.hitech-lcd.com
- [7] CC2511
www.ti.com/cc2511

13 Document history

Revision	Date	Description/Changes
A	2010-02-02	Updated with information about revision 1.8 of SmartRF05EB and updated the troubleshooting section.
-	2009-03-30	First revision.

Appendix A

Schematics

SmartRF05EB revision 1.8.1

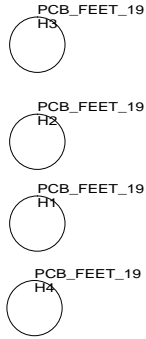

USB MCU IO jumpers

Default setting:

- 1-2: open
- 3-4: open
- 5-6: mount
- 7-8: mount
- 9-10: open
- 11-12: open
- 13-14: open
- 15-16: open
- 17-18: mount
- 19-20: mount
- 21-22: mount
- 23-24: mount
- 25-26: mount
- 27-28: mount
- 29-30: mount
- 31-32: mount
- 33-34: mount
- 35-36: mount

RS-232

- RS232 driver
- RS232 port
- On/Off jumper

USB Interface

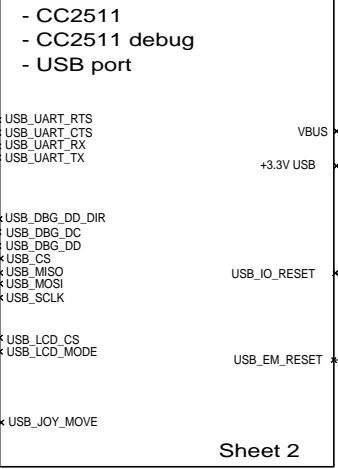

Power Supply

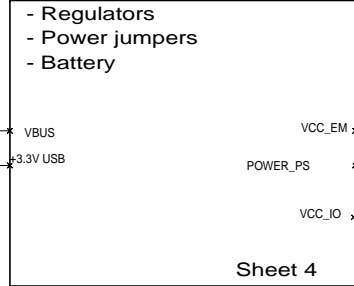

Joystick

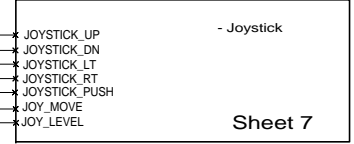

User Interface

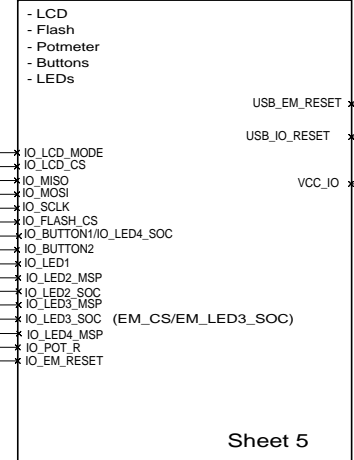

EM Interface

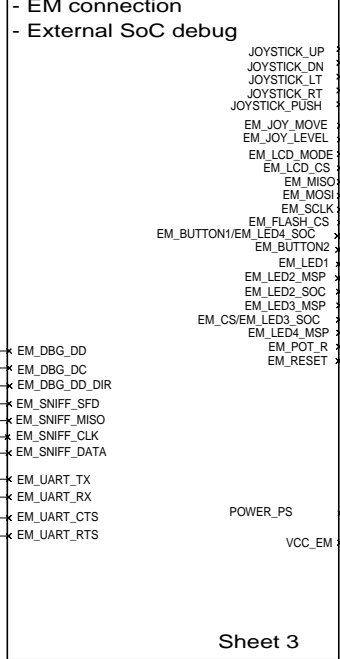

IO peripherals jumpers
All mount as default

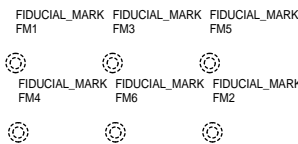
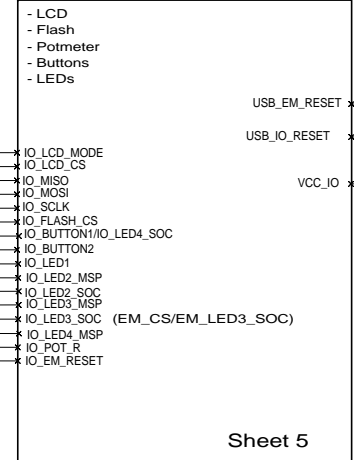
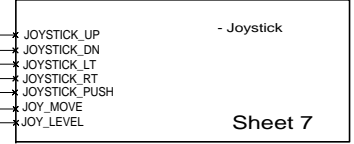
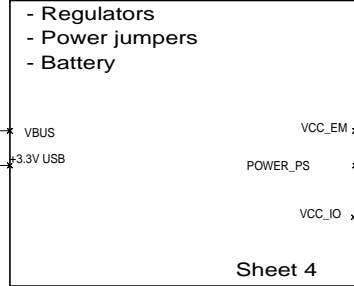
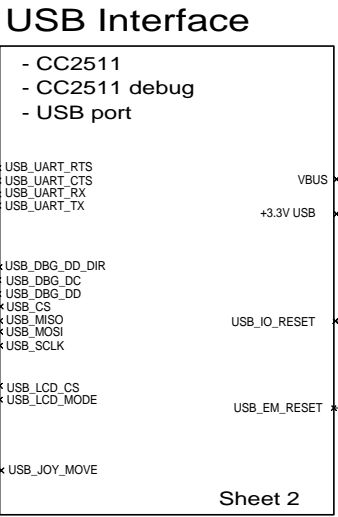
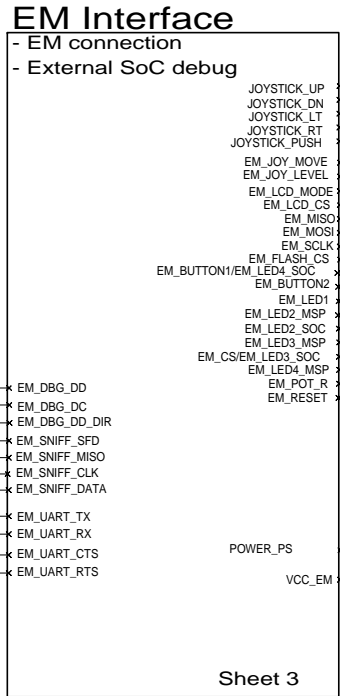
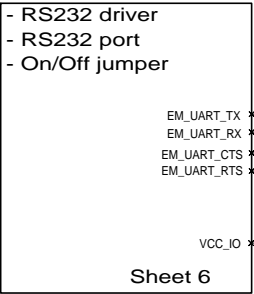
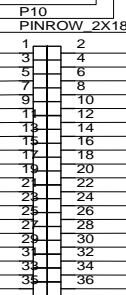
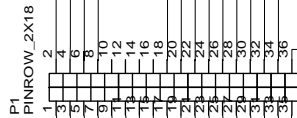

CONTRACT NO. 02587		COMPANY NAME TI Norway, LPW			
APPROVALS	DATE	DWG SmartRF05EB Top Level			
DRAWN	PEH	SIZE A3	FSCM NO.	DWG NO.	REV. 1.8.1
CHECKED		SCALE			SHEET 1(7)
ISSUED					

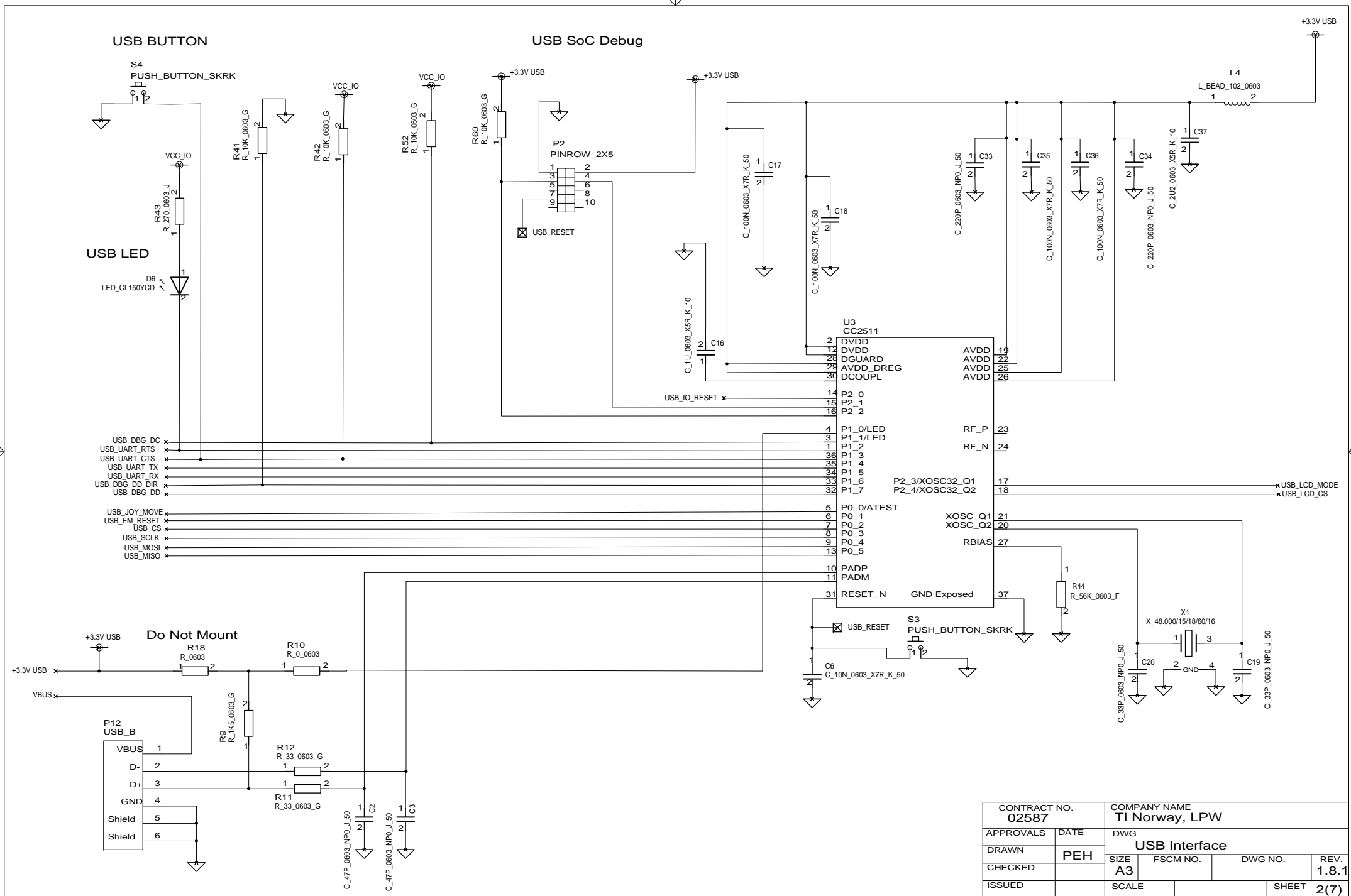

CONTRACT NO. 02587		COMPANY NAME TI Norway, LPW			
APPROVALS	DATE	DWG			
DRAWN	PEH	USB Interface			
CHECKED		SIZE A3	FSCM NO.	DWG NO.	REV. 1.8.1
ISSUED		SCALE			SHEET 2(7)

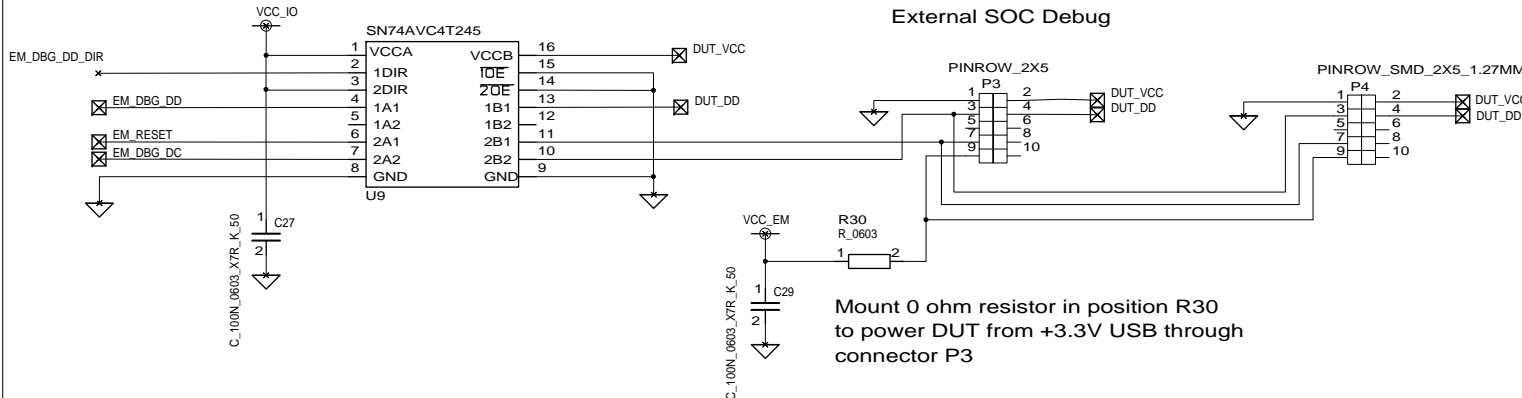

Mount 0 ohm resistor in position R30 to power DUT from +3.3V USB through connector P3

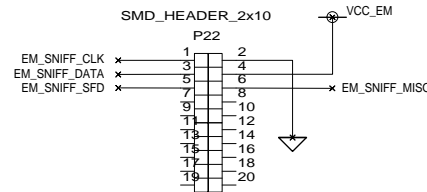
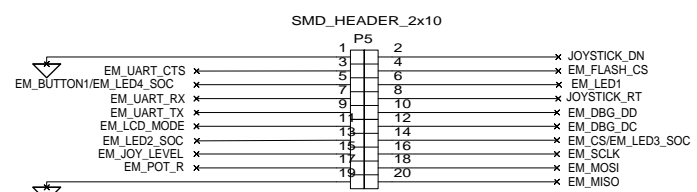

DO NOT MOUNT EM Connectors

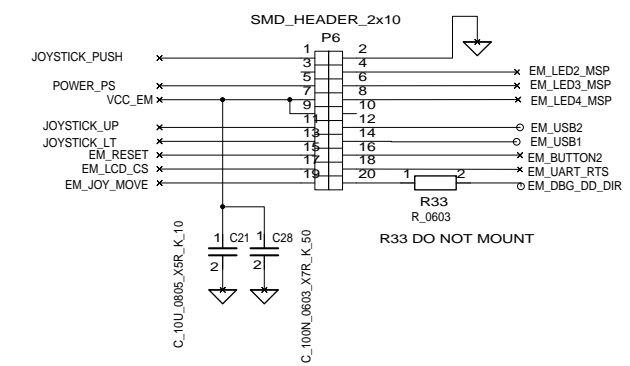

R33 DO NOT MOUNT

Debug Connectors

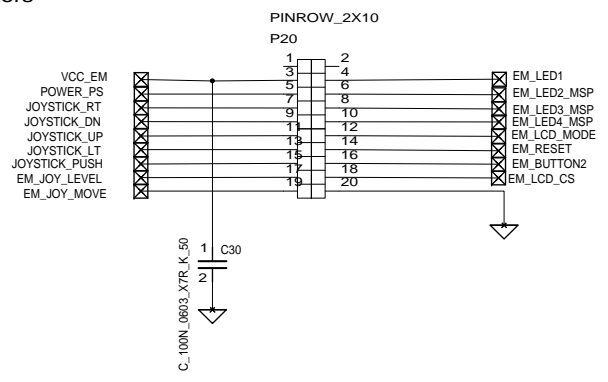
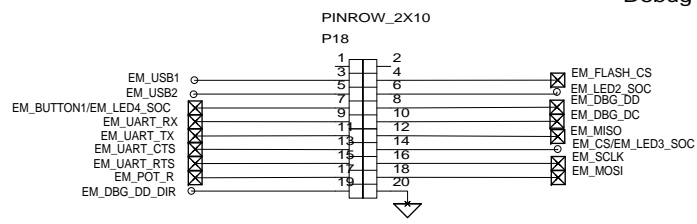

CONTRACT NO. 02587		COMPANY NAME TI Norway, LPW			
APPROVALS	DATE	DWG EM Interface			
DRAWN	PEH	SIZE A3	FSCM NO.	DWG NO.	REV. 1.8.1
CHECKED		SCALE			SHEET 3(7)
ISSUED					

Do Not Mount

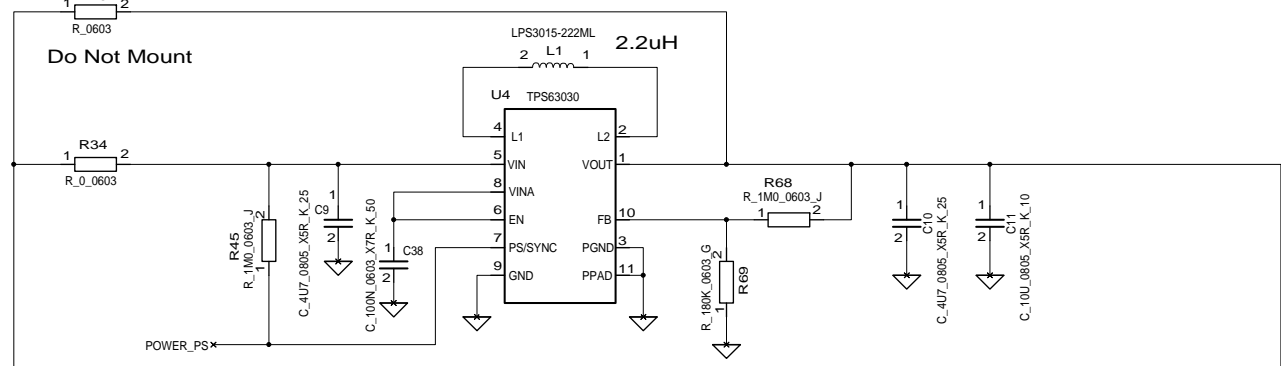

VCC_EM jumper

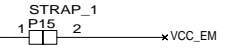

VCC_IO jumper



Battery

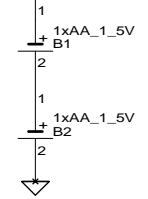

Power On/Off

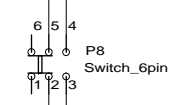

Power source jumper:
1-2: Battery
2-3: USB/DC (default)

Do Not Mount

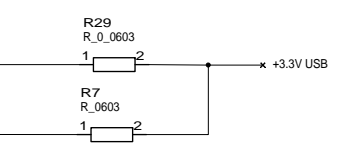
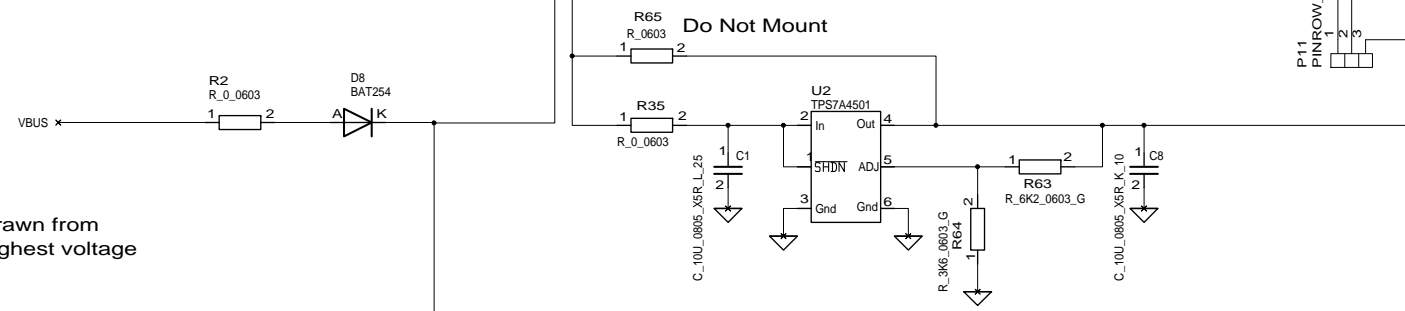

Do Not Mount

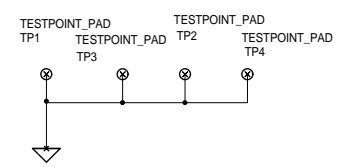

Current is drawn from input with highest voltage

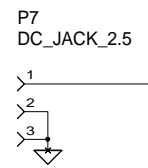

CONTRACT NO. 02587		COMPANY NAME TI Norway, LPW			
APPROVALS	DATE	DWG Power supply			
DRAWN	PEH	SIZE A3	FSCM NO.	DWG NO.	REV. 1.8.1
CHECKED		SCALE		SHEET 4(7)	

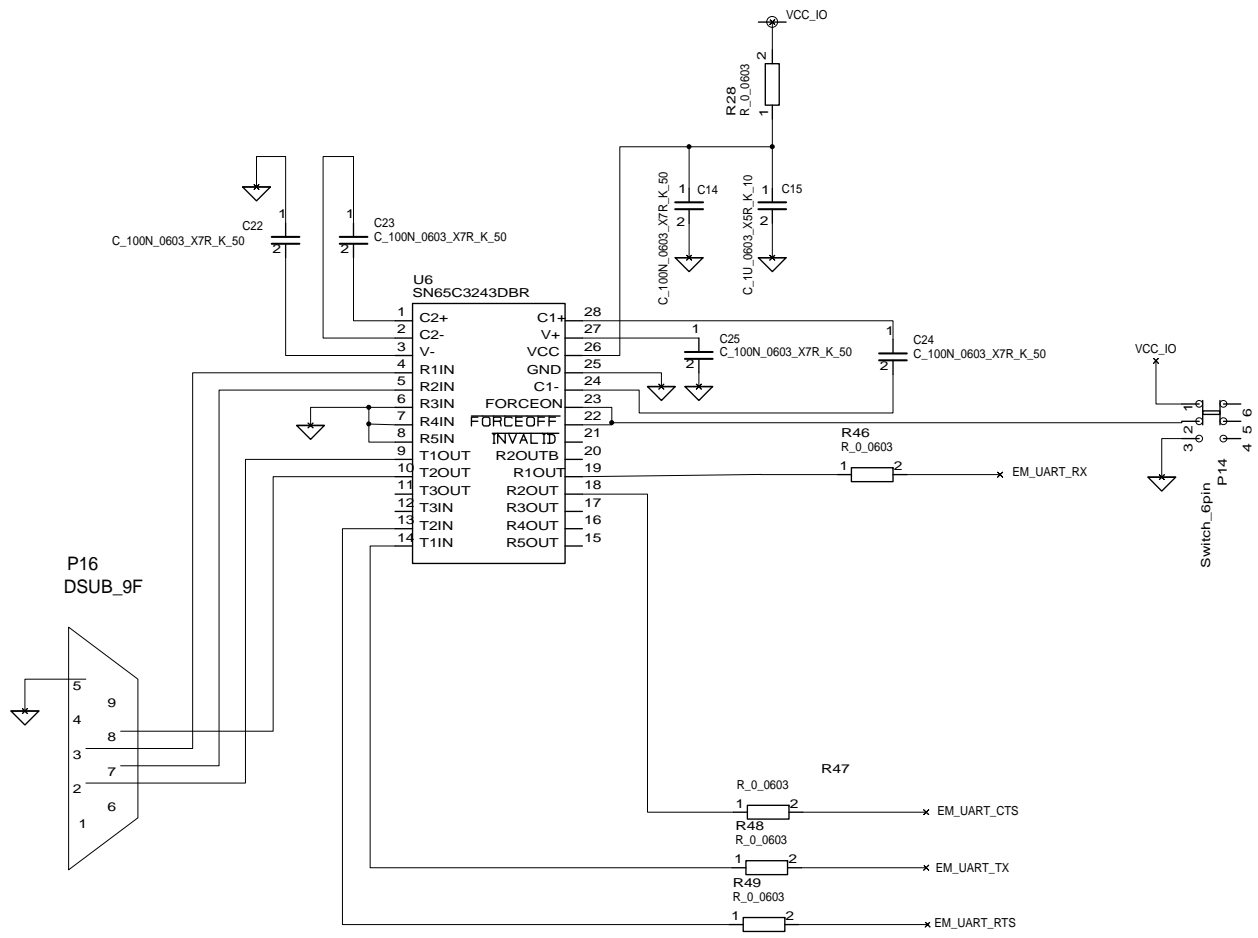

PC RS232-port
 2-RXD
 3-TXD
 5-GND
 7-RTS
 8-CTS

CONTRACT NO. 02587		COMPANY NAME TI Norway, LPW			
APPROVALS	DATE	DWG RS-232 Interface			
DRAWN	PEH	SIZE	FSCM NO.	DWG NO.	REV. 1.8.1
CHECKED		A3			
ISSUED		SCALE			SHEET 6(7)

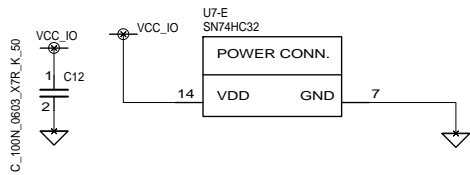
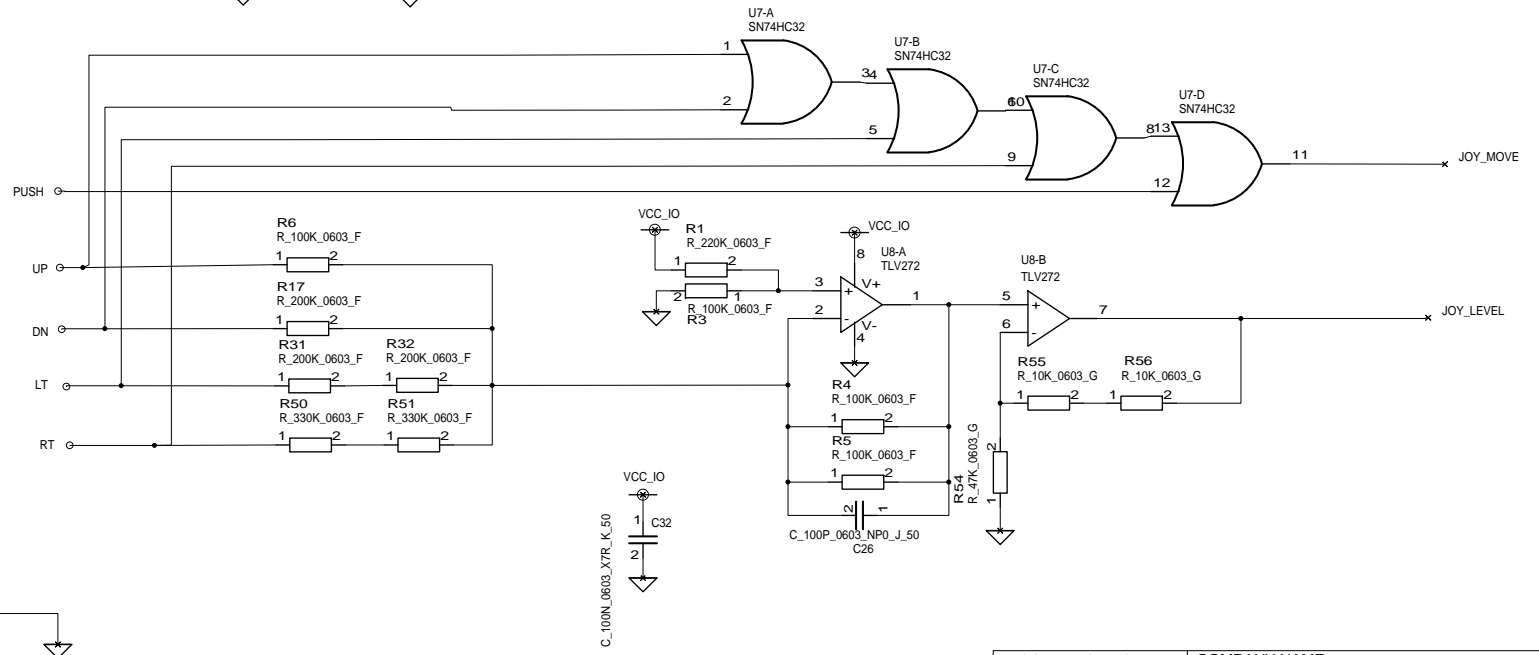
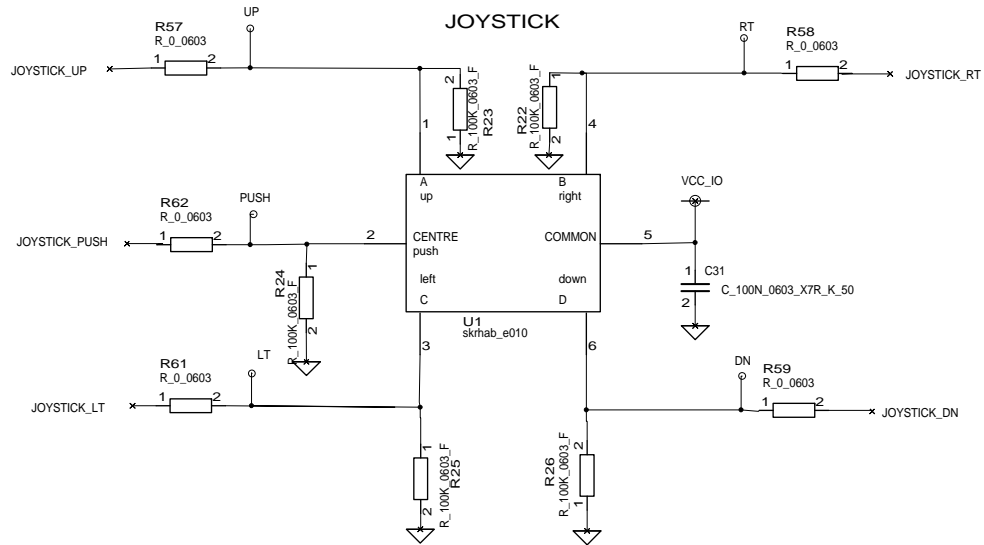

CONTRACT NO. 02587		COMPANY NAME TI Norway, LPW		
APPROVALS	DATE	DWG Joystick		
DRAWN	PEH	SIZE A3	FSCM NO.	DWG NO.
CHECKED				REV. 1.8.1
ISSUED		SCALE		SHEET 7(7)

Appendix B

Schematics

SmartRF05EB revision 1.7.1

- PCB_FEET_19 H3
- PCB_FEET_19 H2
- PCB_FEET_19 H1
- PCB_FEET_19 H4

USB MCU IO jumpers

Default setting:

- 1-2: open
- 3-4: open
- 5-6: mount
- 7-8: mount
- 9-10: open
- 11-12: open
- 13-14: open
- 15-16: open
- 17-18: mount
- 19-20: mount
- 21-22: mount
- 23-24: mount
- 25-26: mount
- 27-28: mount
- 29-30: mount
- 31-32: mount
- 33-34: mount
- 35-36: mount

RS-232

- RS232 driver
- RS232 port
- On/Off jumper

USB Interface

- CC2511
- CC2511 debug
- USB port

USB_UART_RTS
 USB_UART_CTS
 USB_UART_RX
 USB_UART_TX

 USB_DBG_DD_DIR
 USB_DBG_DC
 USB_DBG_DD
 USB_CS
 USB_MISO
 USB_MOSI
 USB_SCLK

 USB_LCD_CS
 USB_LCD_MODE

 USB_JOY_MOVE

Sheet 2

Power Supply

- Regulators
- Power jumpers
- Battery

VBUS
 +3.3V USB

 VCC_EM
 PS_PWR_SNOOZE
 VCC_IO

Sheet 4

Joystick

- Joystick

JOYSTICK_UP
 JOYSTICK_DN
 JOYSTICK_LT
 JOYSTICK_RT
 JOYSTICK_PUSH
 JOY_MOVE
 JOY_LEVEL

Sheet 7

EM Interface

- EM connection
- External SoC debug

JOYSTICK_UP
 JOYSTICK_DN
 JOYSTICK_LT
 JOYSTICK_RT
 JOYSTICK_PUSH
 EM_JOY_MOVE
 EM_JOY_LEVEL
 EM_LCD_MODE
 EM_LCD_CS
 EM_MISO
 EM_MOSI
 EM_SCLK
 EM_FLASH_CS
 EM_BUTTON1/EM_LED4_SOC
 EM_BUTTON2
 EM_LED1
 EM_LED2_MSP
 EM_LED2_SOC
 EM_LED3_MSP
 EM_CS/EM_LED3_SOC
 EM_LED4_MSP
 EM_POT_R
 EM_RESET

 PS_PWR_SNOOZE
 VCC_EM

Sheet 3

User Interface

- LCD
- Flash
- Potmeter
- Buttons
- LEDs

IO_LCD_MODE
 IO_LCD_CS
 IO_MISO
 IO_MOSI
 IO_SCLK
 IO_FLASH_CS
 IO_BUTTON1/IO_LED4_SOC
 IO_BUTTON2
 IO_LED1
 IO_LED2_MSP
 IO_LED2_SOC
 IO_LED3_MSP
 IO_CS/IO_LED3_SOC
 IO_LED4_MSP
 IO_POT_R
 IO_EM_RESET

Sheet 5

IO peripherals jumpers
All mount as default

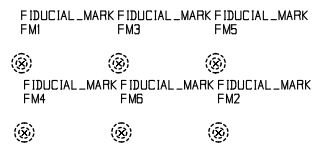
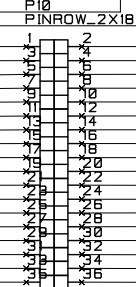
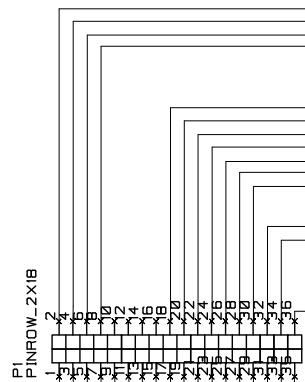

CONTRACT NO. 02587		COMPANY NAME TI Norway, LPW			
APPROVALS	DATE	DWG SmartRF05EB Top Level			
DRAWN	PEH	SIZE A3	FSCM NO.	DWG NO.	REV. 1.7.1
CHECKED		SCALE		SHEET 1(7)	
ISSUED					

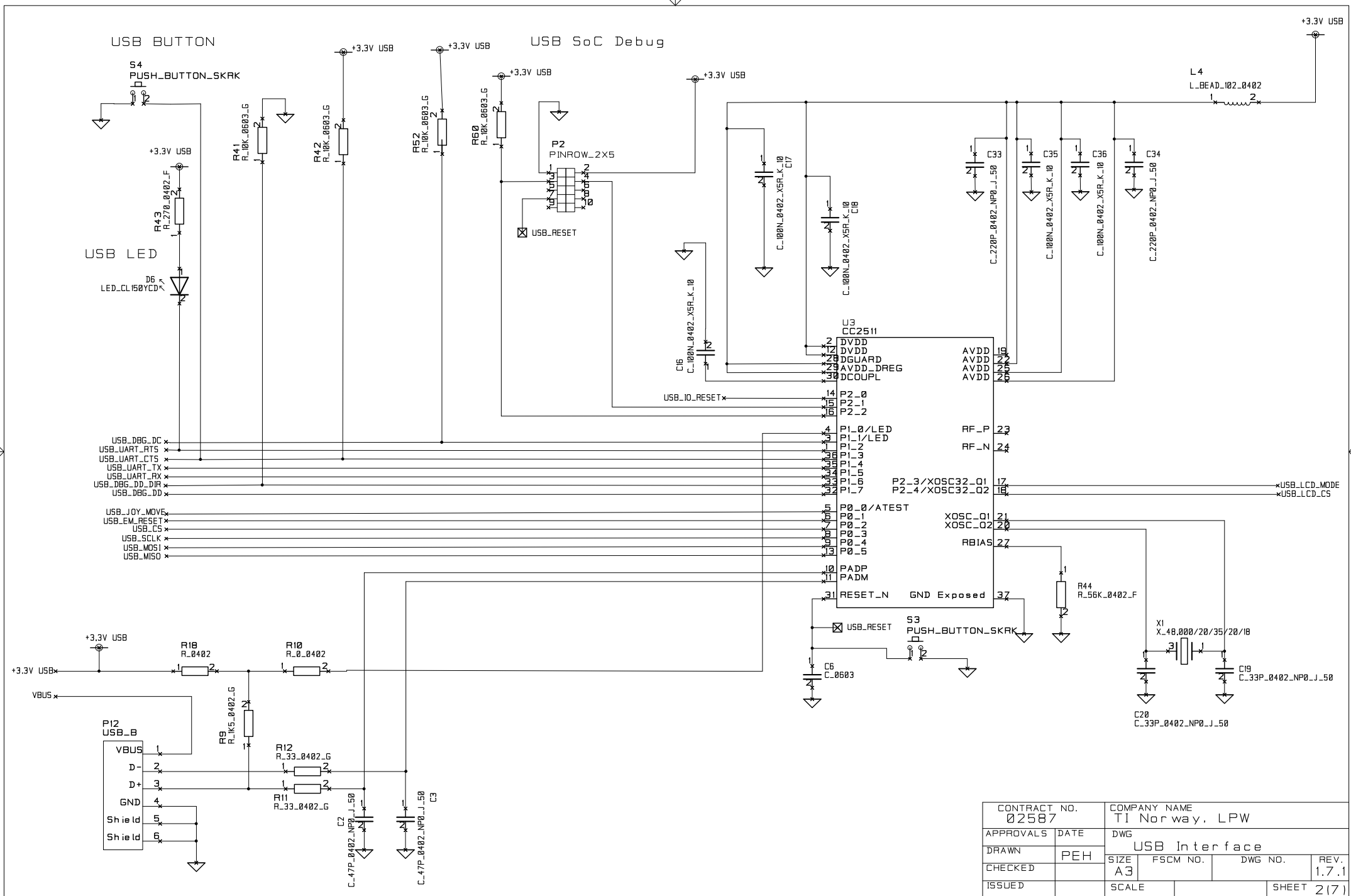

CONTRACT NO. 02587		COMPANY NAME TI Norway, LPW		
APPROVALS	DATE	DWG USB Interface		
DRAWN	PEH	SIZE A3	FSCM NO.	DWG NO.
CHECKED				REV. 1.7.1
ISSUED		SCALE		SHEET 2 (7)

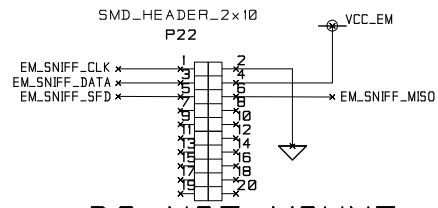
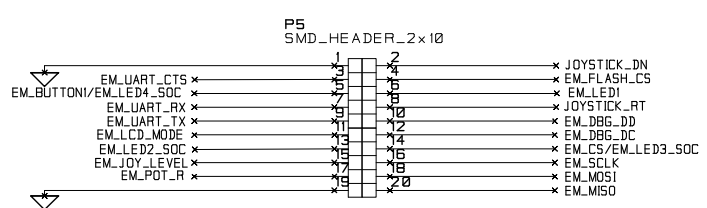
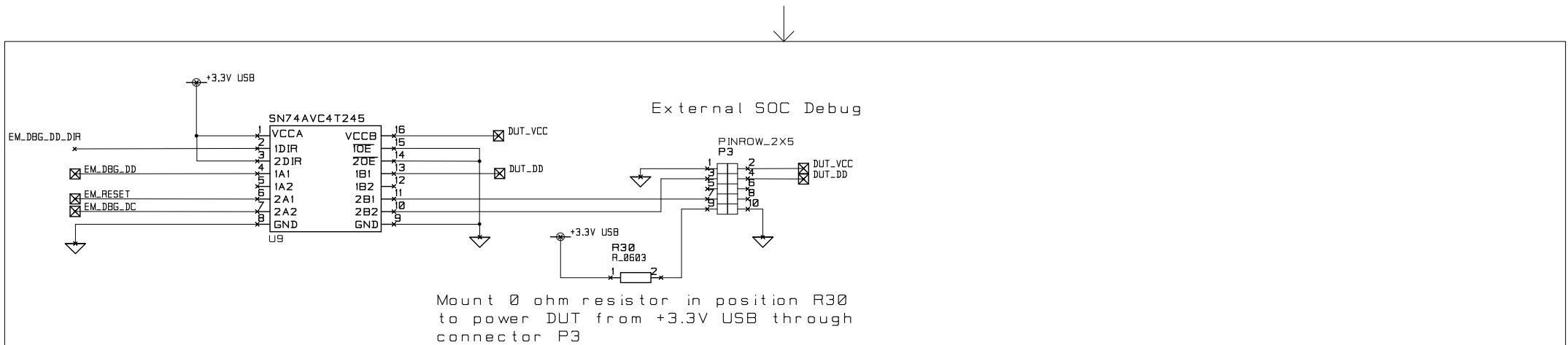

DO NOT MOUNT
EM Connectors

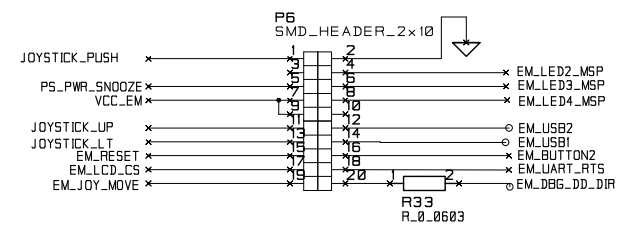

Debug Connectors

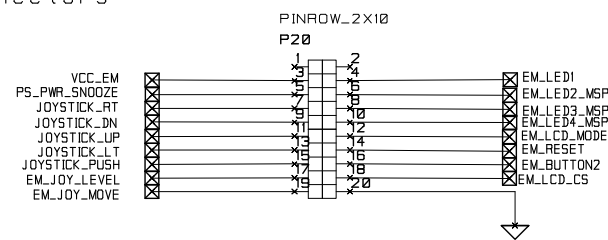
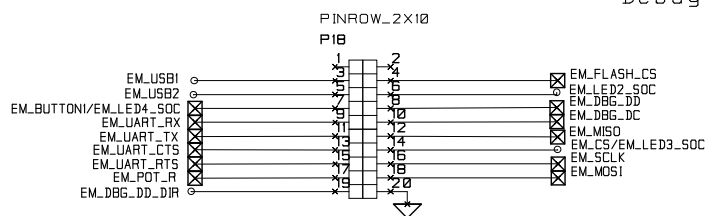

CONTRACT NO. 02587		COMPANY NAME TI Norway, LPW		
APPROVALS	DATE	DWG EM Interface		
DRAWN	PEH	SIZE A3	FSCM NO.	DWG NO.
CHECKED				REV. 1.7.1
ISSUED		SCALE		SHEET 3(7)

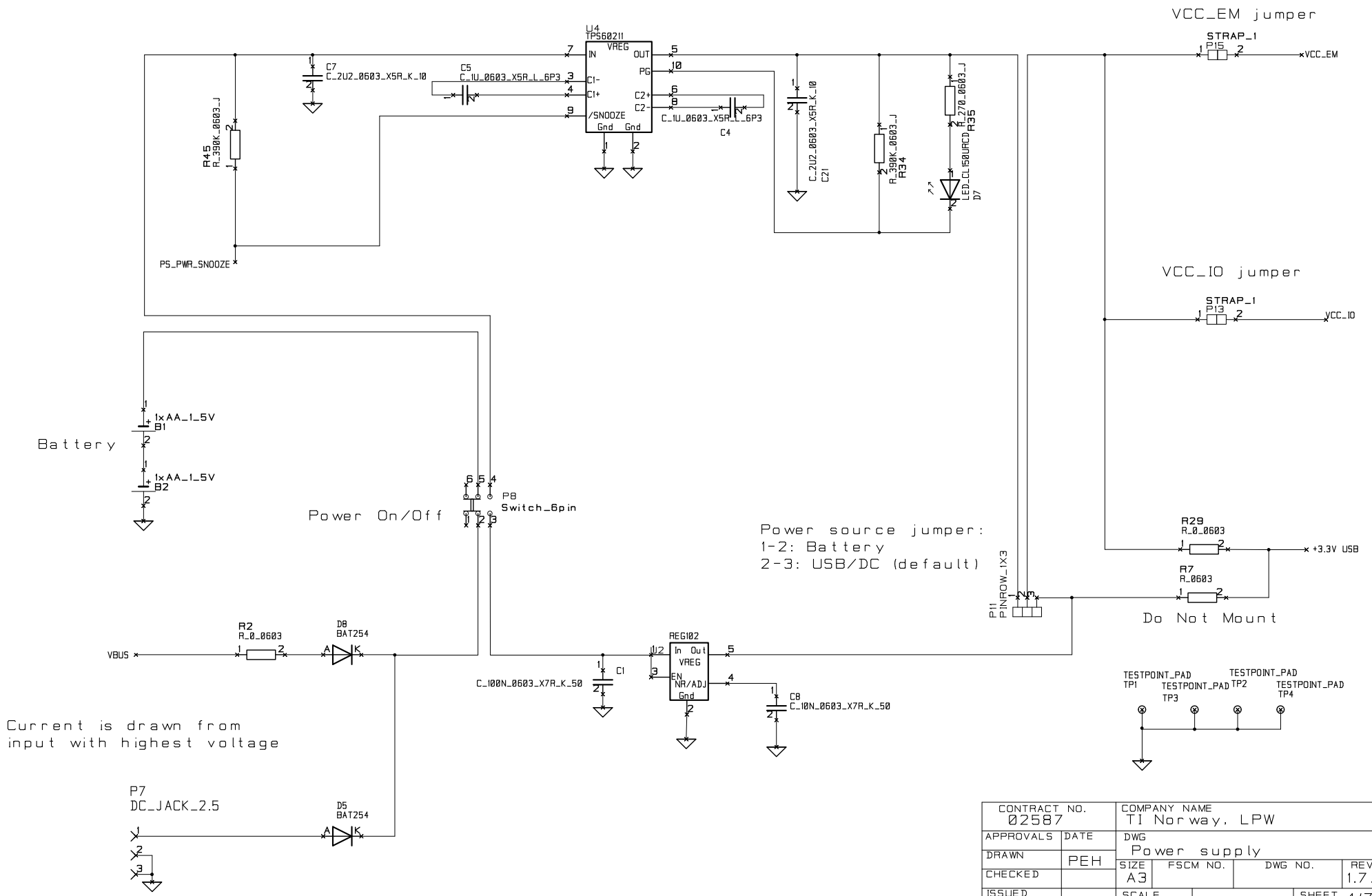

CONTRACT NO. 02587		COMPANY NAME TI Norway, LPW		
APPROVALS	DATE	DWG Power supply		
DRAWN	PEH	SIZE A3	FSCM NO.	DWG NO.
CHECKED				REV. 1.7.1
ISSUED		SCALE		SHEET 4 (7)

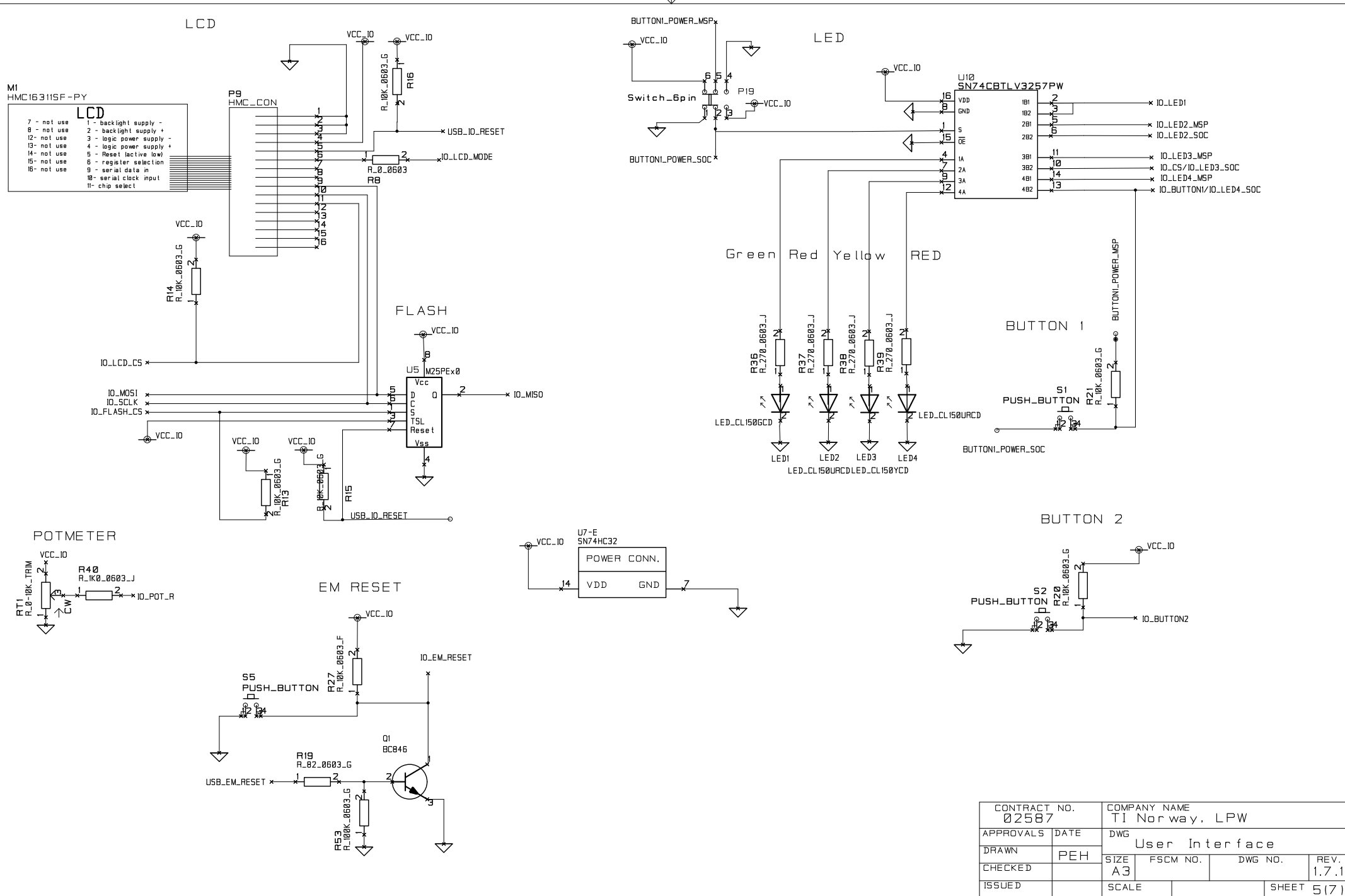

CONTRACT NO. 02587		COMPANY NAME TI Norway, LPW		
APPROVALS	DATE	DWG User Interface		
DRAWN	PEH	SIZE A3	FSCM NO.	DWG NO.
CHECKED				REV. 1.7.1
ISSUED		SCALE		SHEET 5(7)

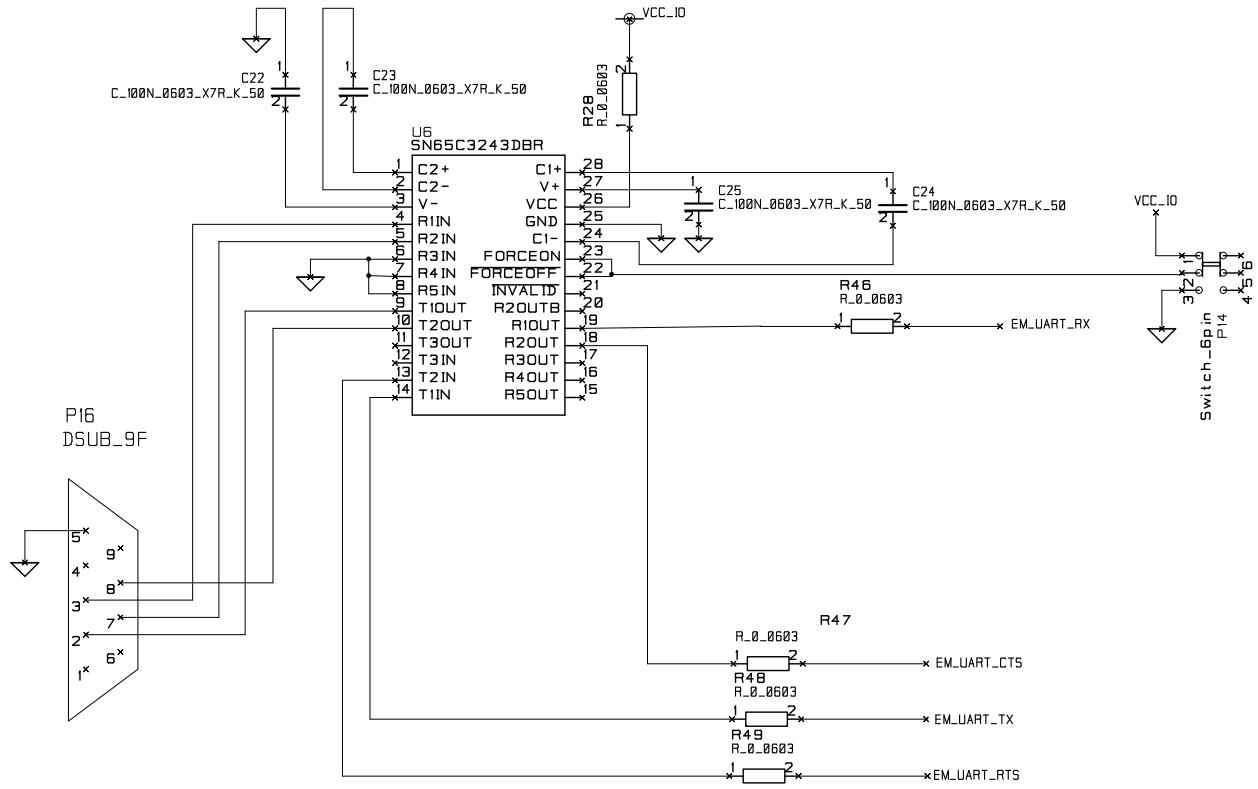

PC RS232-port
 2-RXD
 3-TXD
 5-GND
 7-RTS
 8-CTS

CONTRACT NO. 02587		COMPANY NAME TI Norway, LPW			
APPROVALS	DATE	DWG RS-232 Interface			
DRAWN	PEH	SIZE A3	FSCM NO.	DWG NO.	REV. 1.7.1
CHECKED		SCALE			SHEET 6 (7)
ISSUED					

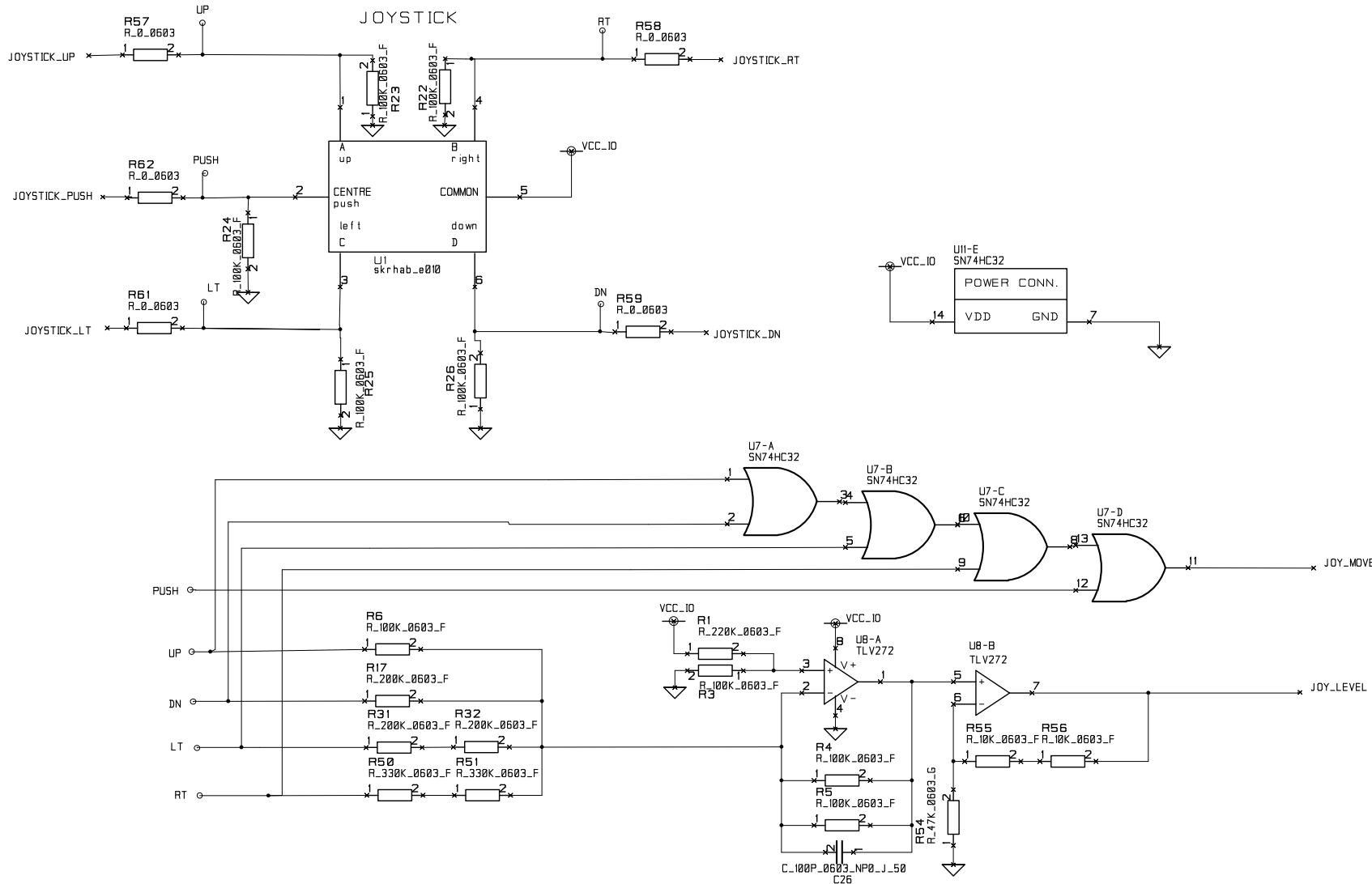

CONTRACT NO. 02587		COMPANY NAME TI Norway, LPW			
APPROVALS	DATE	DWG Joystick			
DRAWN	PEH	SIZE A3	FSCM NO.	DWG NO.	REV. 1.7.1
CHECKED					
ISSUED		SCALE			SHEET 7 (7)

Appendix C

Schematics

SmartRF05EB revision 1.3

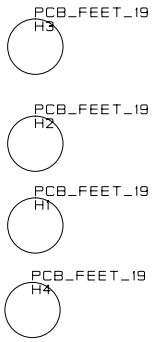

USB MCU IO jumpers

Default setting:
 1-2: open
 3-4: open
 5-6: mount
 7-8: mount
 9-10: open
 11-12: open
 13-14: open
 15-16: open
 17-18: mount
 19-20: mount
 21-22: mount
 23-24: mount
 25-26: mount
 27-28: mount
 29-30: mount
 31-32: mount
 33-34: mount
 35-36: mount
 37-38: mount

RS-232
 - RS232 driver
 - RS232 port
 - On/Off jumper

USB Interface

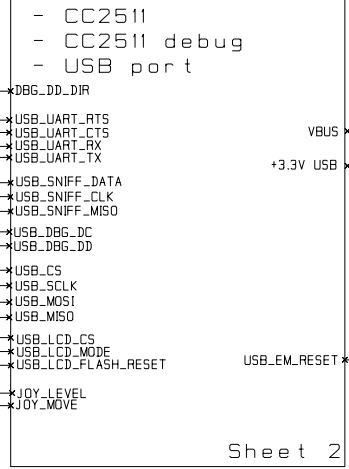

Power Supply

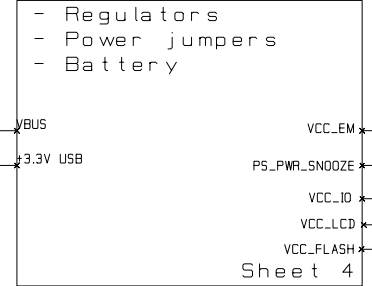

User Interface

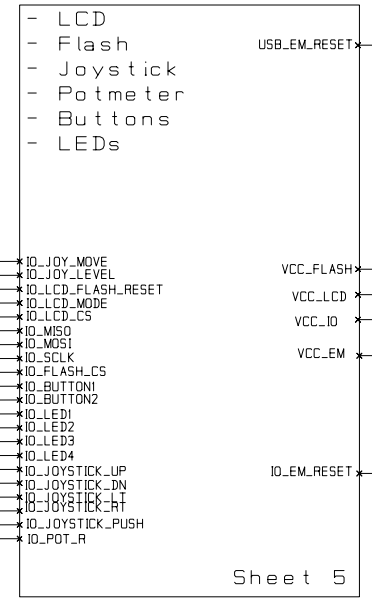

EM Interface

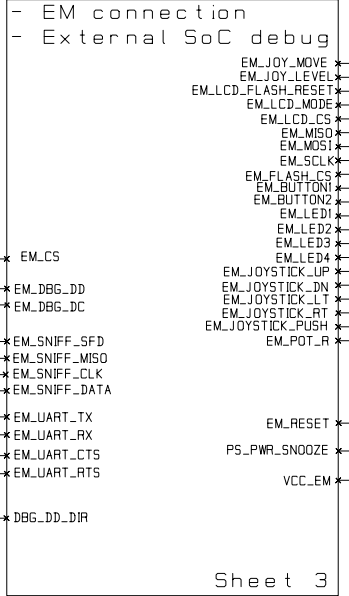

IO peripherals jumpers
 All mount as default

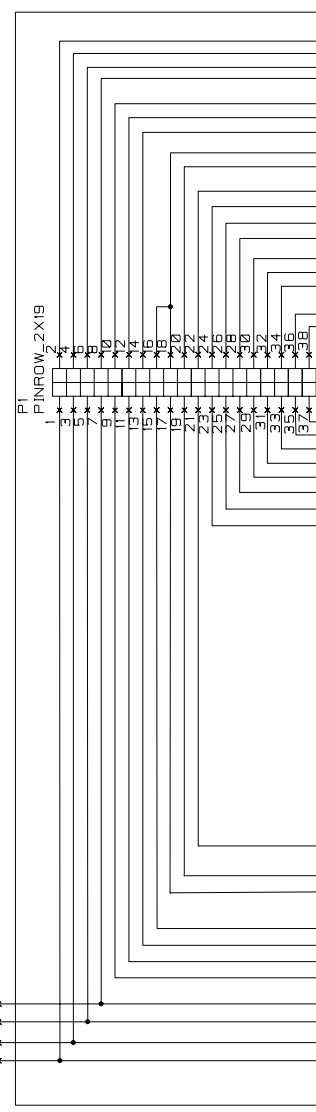

CONTRACT NO. 02587		COMPANY NAME TI Norway, LPW			
APPROVALS	DATE	DWG SmartRF05EB Top Level			
DRAWN	TAL	SIZE A3	FSCM NO.	DWG NO.	REV. 1.3
CHECKED		SCALE		SHEET 1(6)	
ISSUED					

Sheet 6

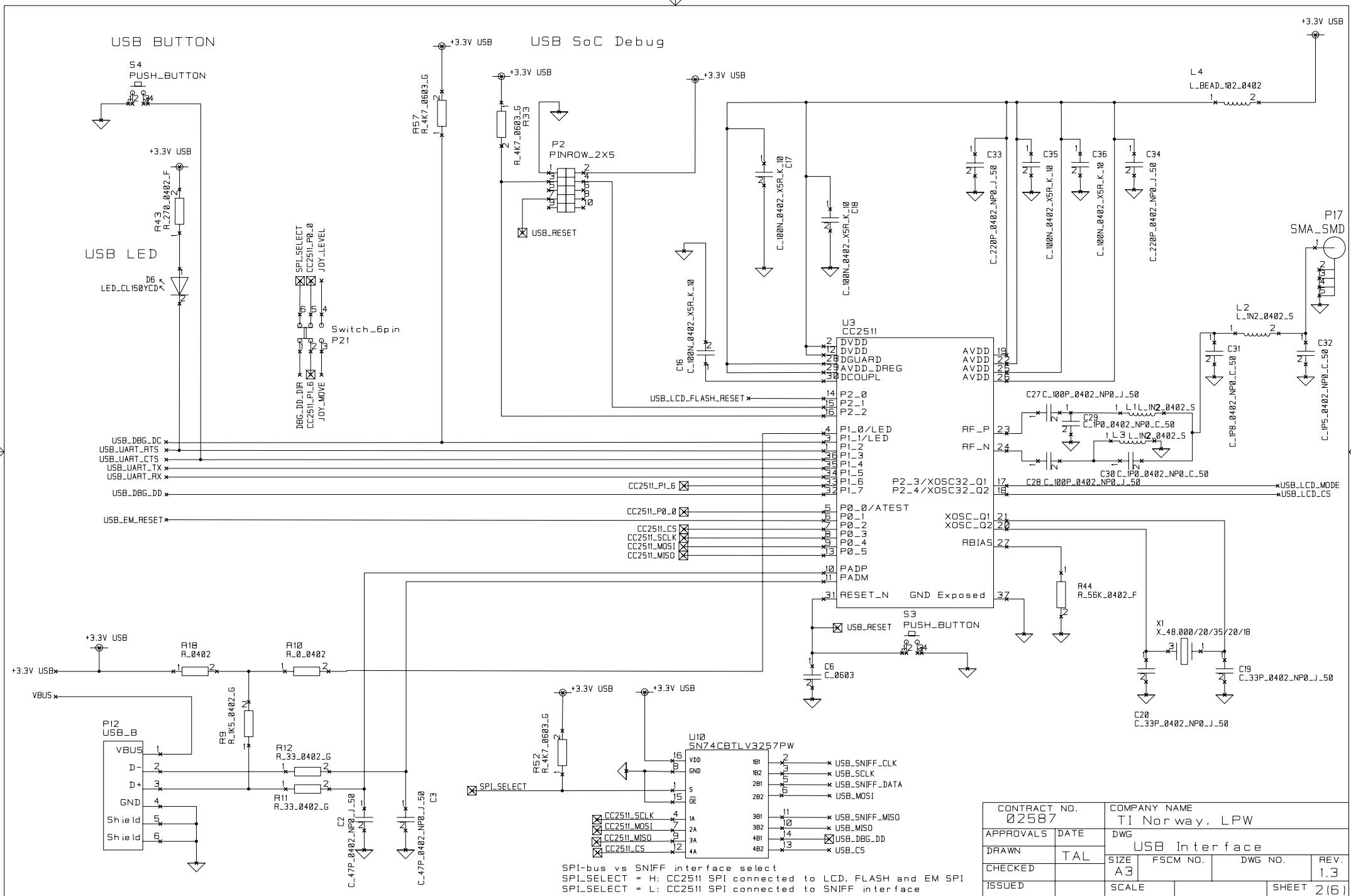

SPI-bus vs SNIFF interface select
 SPI_SELECT = H: CC2511 SPI connected to LCD, FLASH and EM SPI
 SPI_SELECT = L: CC2511 SPI connected to SNIFF interface

CONTRACT NO. 02587		COMPANY NAME TI Norway, LPW			
APPROVALS	DATE	DWG USB Interface			
DRAWN	TAL	SIZE A3	FSCM NO.	DWG NO.	REV. 1.3
CHECKED		SCALE		SHEET 2 (6)	
ISSUED					

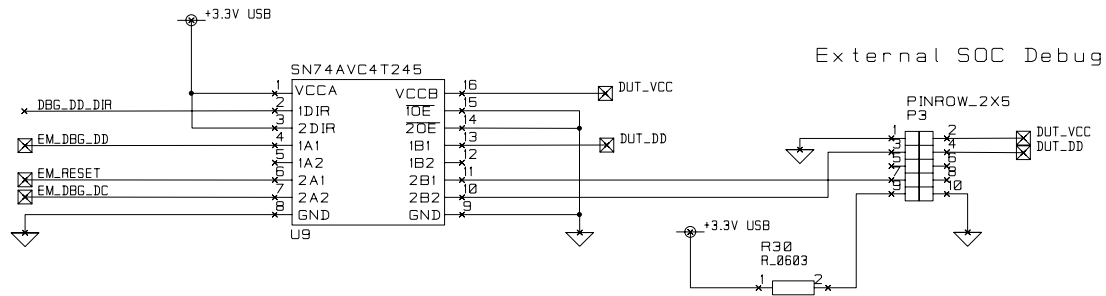

Mount 0 ohm resistor in position R30 to power DUT from +3.3V USB through connector P3

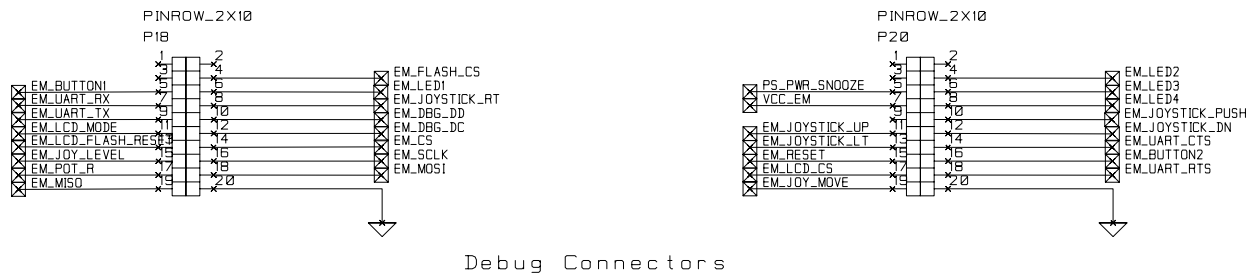
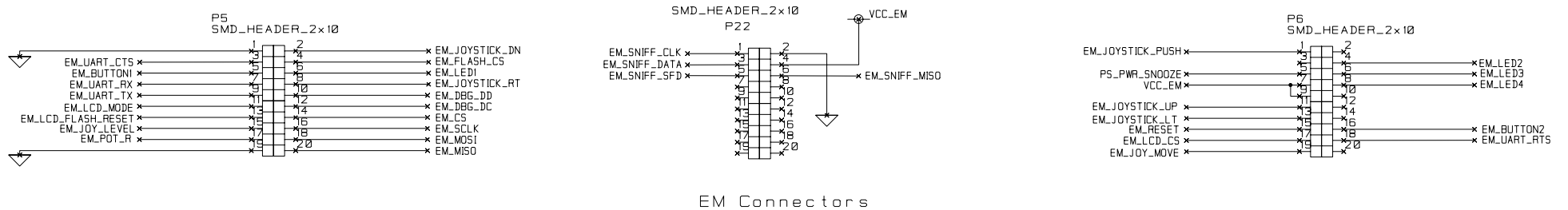

Debug connectors mirror EM connectors with a few exceptions.
 Exceptions: Pins 1, 2 and 3 left unconnected, GND connected to pin 20.
 Reason for exception is to be able to connect an Agilent logic analyzer probe directly to the debug connector.

CONTRACT NO. 02587		COMPANY NAME TI Norway, LPW			
APPROVALS	DATE	DWG EM Interface			
DRAWN	TAL	SIZE A3	FSCM NO.	DWG NO.	REV. 1.3
CHECKED					
ISSUED		SCALE			SHEET 3/6

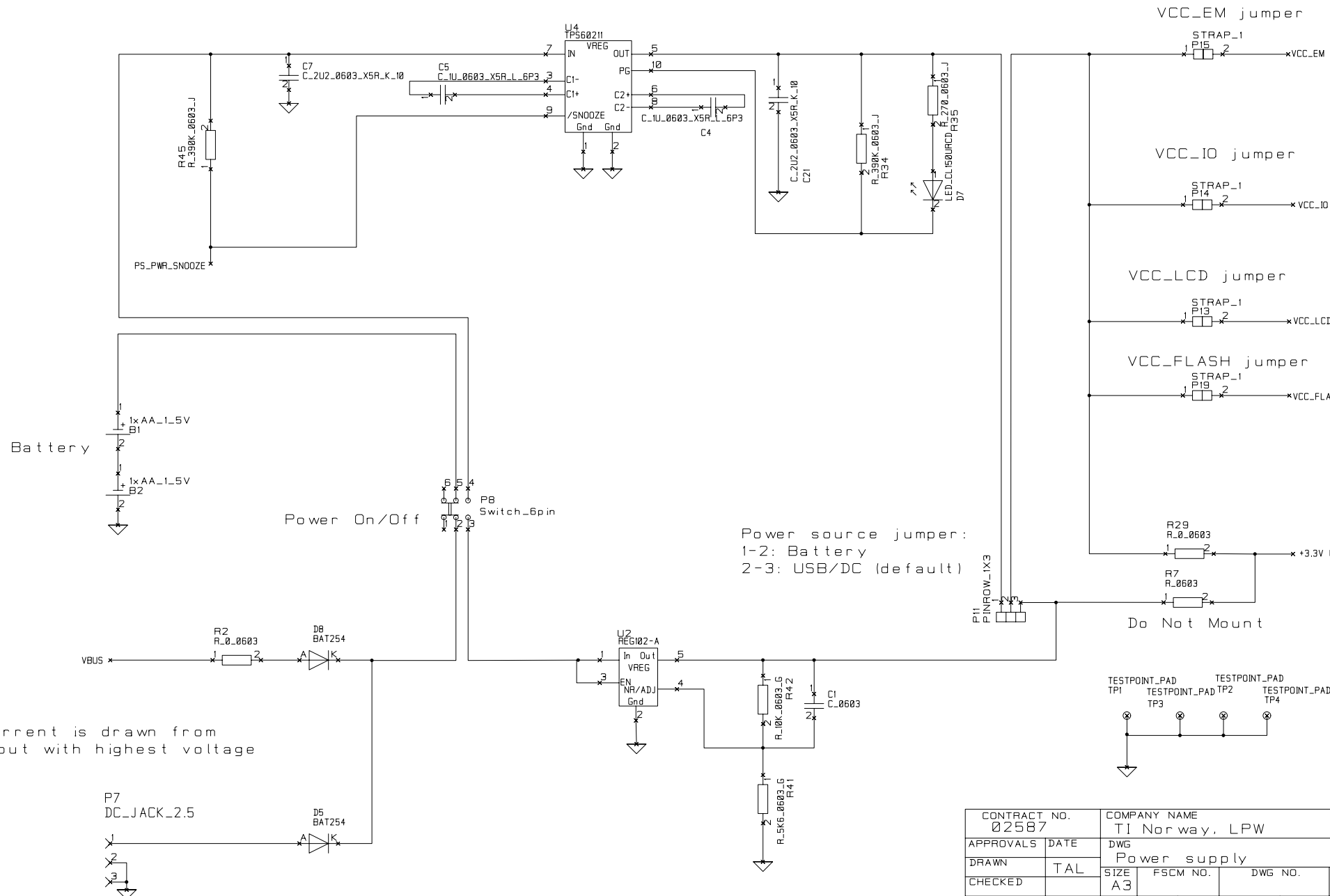

Power source jumper:
 1-2: Battery
 2-3: USB/DC (default)

Current is drawn from input with highest voltage

CONTRACT NO. 02587		COMPANY NAME TI Norway, LPW			
APPROVALS	DATE	DWG Power supply			
DRAWN	TAL	SIZE A3	FSCM NO.	DWG NO.	REV. 1.3
CHECKED		SCALE		SHEET 4 (6)	
ISSUED					

M1
HMC16311SF-PY

LCD	
7 - not use	1 - backlight supply -
8 - not use	2 - backlight supply +
12 - not use	3 - logic power supply -
13 - not use	4 - logic power supply +
14 - not use	5 - Reset lactive low
15 - not use	6 - register selection
16 - not use	9 - serial data in
	10 - serial clock input
	11 - chip select

LCD

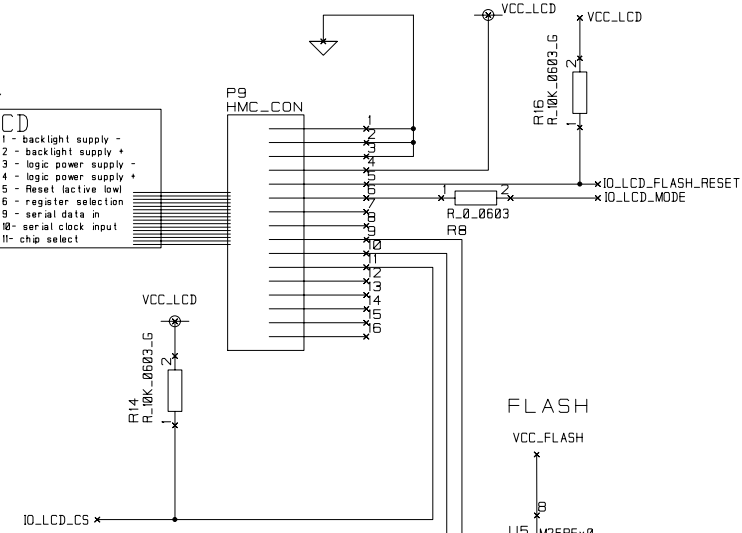

FLASH

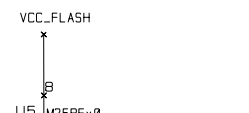

POTMETER

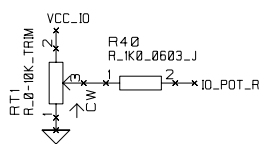

BUTTON 2

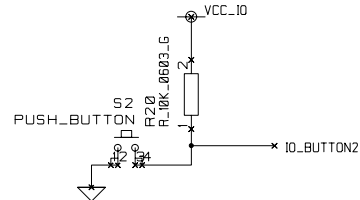

EM RESET

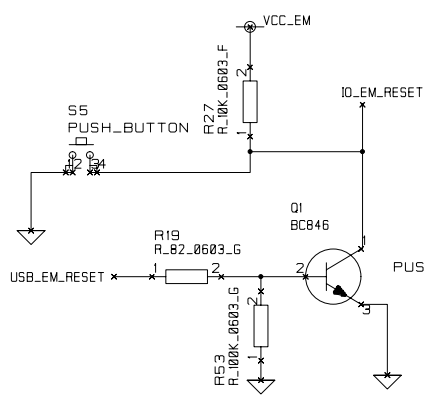

BUTTON 1

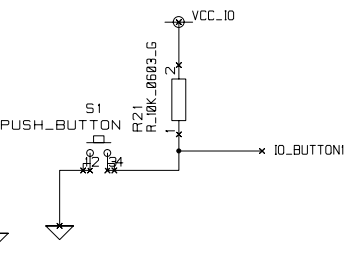

LED

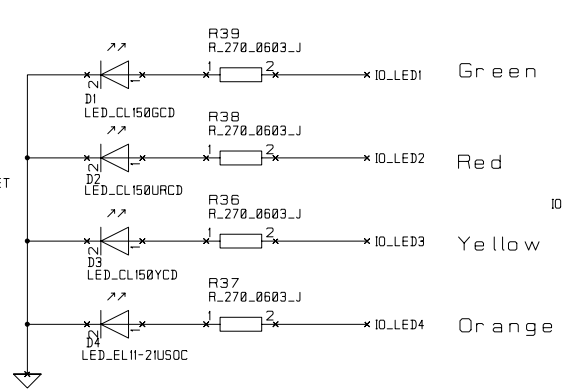

JOYSTICK

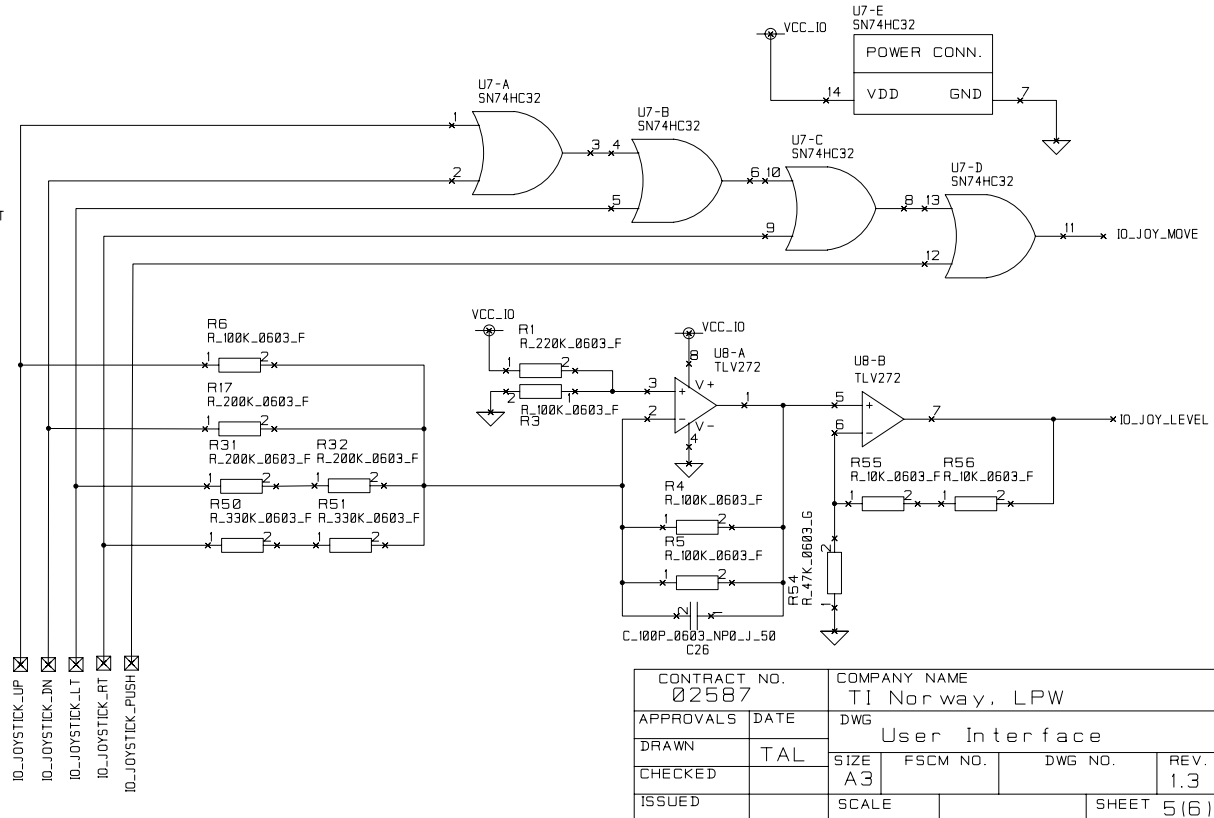
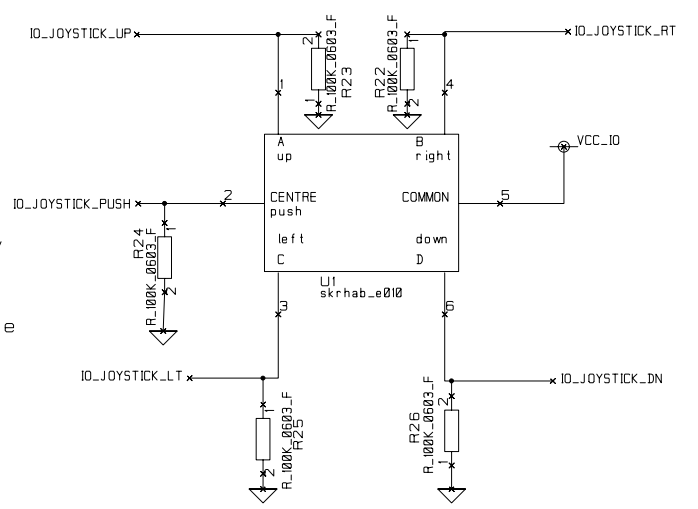

CONTRACT NO. 02587		COMPANY NAME TI Norway, LPW			
APPROVALS	DATE	DWG User Interface			
DRAWN	TAL	SIZE A3	FSCM NO.	DWG NO.	REV. 1.3
CHECKED		SCALE		SHEET 5 (6)	
ISSUED					

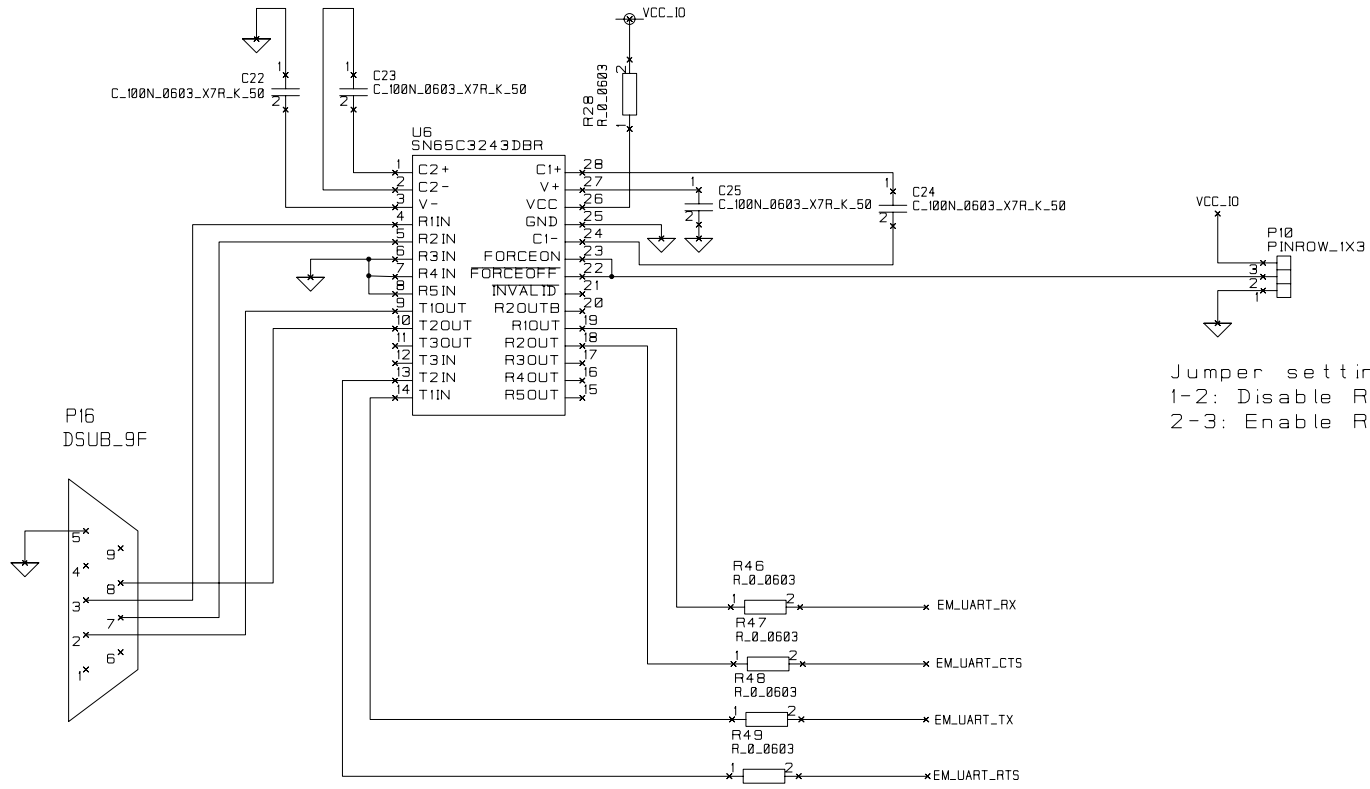

Jumper setting:
 1-2: Disable RS232-port
 2-3: Enable RS232-port (Default)

PC RS232-port
 2-RXD
 3-TXD
 5-GND
 7-RTS
 8-CTS

CONTRACT NO. 02587		COMPANY NAME TI Norway, LPW			
APPROVALS	DATE	DWG RS-232 Interface			
DRAWN	TAL	SIZE A3	FSCM NO.	DWG NO.	REV. 1.3
CHECKED		SCALE			SHEET 6 (6)
ISSUED					

IMPORTANT NOTICE AND DISCLAIMER

TI PROVIDES TECHNICAL AND RELIABILITY DATA (INCLUDING DATASHEETS), DESIGN RESOURCES (INCLUDING REFERENCE DESIGNS), APPLICATION OR OTHER DESIGN ADVICE, WEB TOOLS, SAFETY INFORMATION, AND OTHER RESOURCES "AS IS" AND WITH ALL FAULTS, AND DISCLAIMS ALL WARRANTIES, EXPRESS AND IMPLIED, INCLUDING WITHOUT LIMITATION ANY IMPLIED WARRANTIES OF MERCHANTABILITY, FITNESS FOR A PARTICULAR PURPOSE OR NON-INFRINGEMENT OF THIRD PARTY INTELLECTUAL PROPERTY RIGHTS.

These resources are intended for skilled developers designing with TI products. You are solely responsible for (1) selecting the appropriate TI products for your application, (2) designing, validating and testing your application, and (3) ensuring your application meets applicable standards, and any other safety, security, regulatory or other requirements.

These resources are subject to change without notice. TI grants you permission to use these resources only for development of an application that uses the TI products described in the resource. Other reproduction and display of these resources is prohibited. No license is granted to any other TI intellectual property right or to any third party intellectual property right. TI disclaims responsibility for, and you fully indemnify TI and its representatives against any claims, damages, costs, losses, and liabilities arising out of your use of these resources.

TI's products are provided subject to [TI's Terms of Sale](#), [TI's General Quality Guidelines](#), or other applicable terms available either on ti.com or provided in conjunction with such TI products. TI's provision of these resources does not expand or otherwise alter TI's applicable warranties or warranty disclaimers for TI products. Unless TI explicitly designates a product as custom or customer-specified, TI products are standard, catalog, general purpose devices.

TI objects to and rejects any additional or different terms you may propose.

Copyright © 2026, Texas Instruments Incorporated

Last updated 10/2025