

Using the TPS2420, TPS2421-1 and TPS2421-2

User's Guide



Literature Number: SLUU343
January 2009

TPS2420 Hot Swap Controller System Test Board

This user's guide describes the setup and operation of the TPS2420 system test board.

1 Introduction

This user's guide describes the features of the TPS242X EVM. The TPS242X schematic, layout and List of Materials are provided as well as a setup and getting started.

2 Description

The EVM is a 3 V to 18 V module using the TPS2420/21 hot swap controller with integrated MOSFET. At power on, the output is power limited to control inrush current and protect the MOSFET. On an over-current condition, the controller interrupts power to the load at high speed and signals load status. Operating current, fault current and fault timer settings are hardware programmable.

2.1 Applications

2.1.1 Server

- Plug-In Circuit Boards
- RAID / Disk Drive

2.1.2 Telecom

- ATCA
- Micro-ATCA

2.2 Features

- 3-V to 18-V Operation
- Controlled Inrush Current
- Fast Circuit Breaker Control
- Hardware Programmable
 - Operating Current
 - Fault Current
 - Fault Timer to Avoid Nuisance Tripping
 - Latch Off or Retry (TPS2420 is pin selectable, TPS2421-1 is latch-off only and TPS2421-2 is re-try only.)
- LED status display
- A Slide Switch Controls the ENABLE Signal.
- The Area Under the TPS2420/1 is Copper Pour with Vias to the Internal Ground to take Advantage of the Power Pad Package.
- A Transorb is On-Board for Over-Voltage Input Protection
- A Common Diode at the Output Prevents a Negative Spike if the Load is Removed While Powered On
- Programmable I_{MON} Voltage Readout of the Output Current is Preset to 0.31 V / A
- Test Points Available to Monitor Circuit Operation

3 Block Diagram

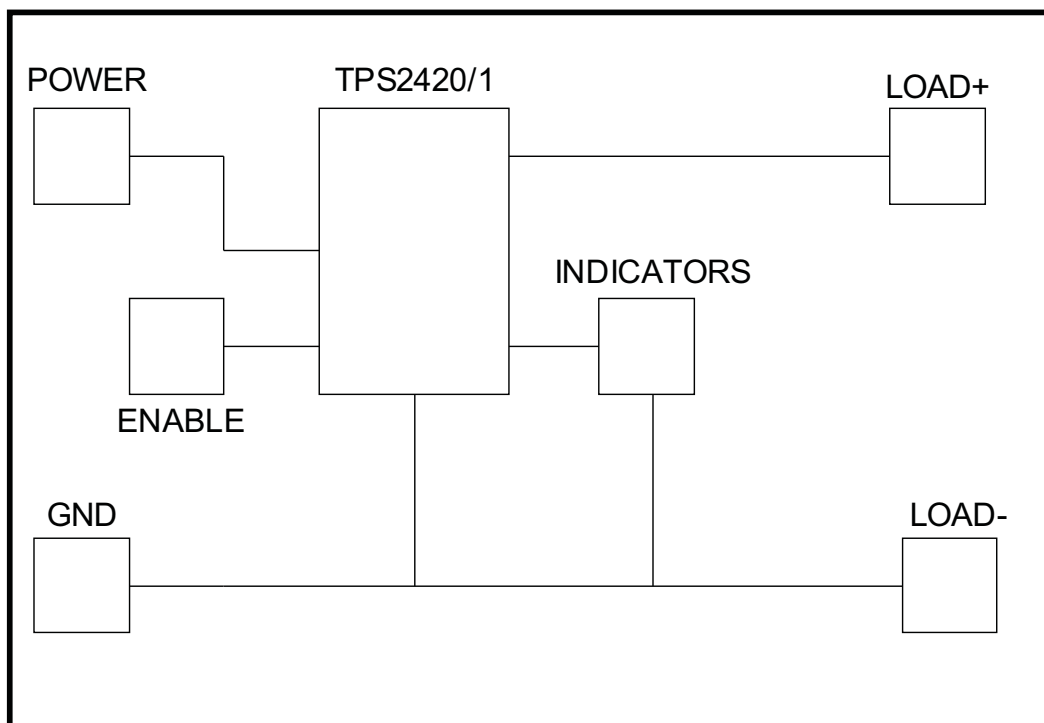

Figure 1. EVM Block Diagram

4 Schematic

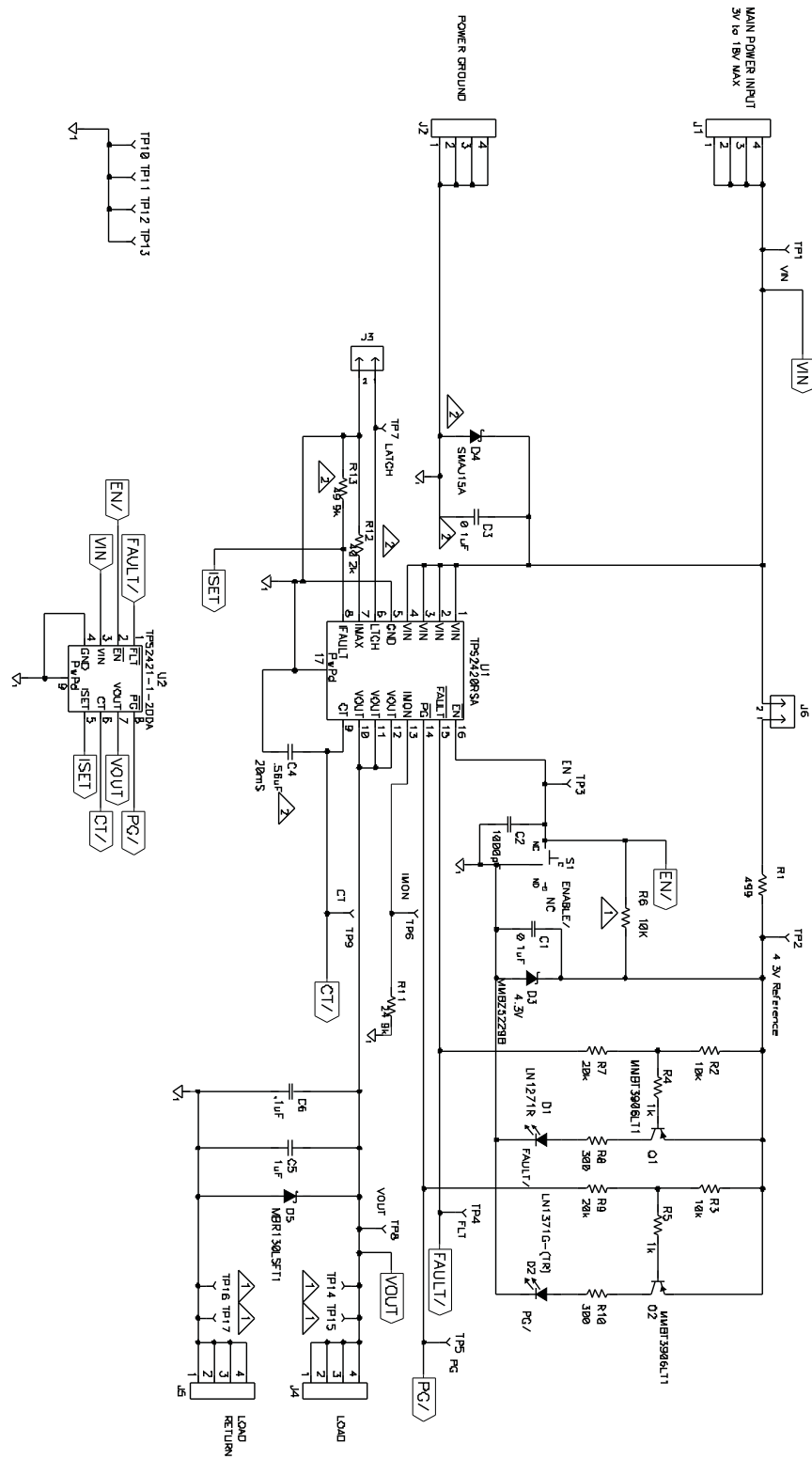

Figure 2. TPS2420 Schematic

5 List of Materials

This is the List of Material for the TPS242X EVM

Table 1. List of Materials

COUNT	REF DES	DESCRIPTION	PART NUMBER	MFR
2	C1, C3	Capacitor, ceramic, 0.1 μ F, 603	STD	muRata
2	C2, C6	Capacitor, ceramic, 0.1 μ F, 603	STD	muRata
1	C4	Capacitor, ceramic, 10V , 0.56 μ F, 805	STD	muRata
1	C5	Capacitor, ceramic, 25 V, 1 μ F, 1206	STD	muRata
1	D1	Diode, LED, red, 20 mA, 0.9 mcd, 0.068 x 0.049 inch	LN1271R	Panasonic
1	D2	Diode, LED, green, 20 mA, 0.9 mcd, 0.068 x 0.049 inch	LN1371G-(TR)	Panasonic
1	D3	Diode, Zener, 4.3 V, SOT23	MMBZ5229B	Motorola
1	D4	Diode, SMT TVS 400 W, 1 A, 15 V, SMA	SMAJ15A	Diodes
1	D5	Diode, Schottky, 1000 mA, 30 V, SOD123	MBR130LSFT1	STD
4	J1, J2, J4, J5	Screw terminal, 0.310 x 0.310 inch	7693	Keystone
1	J3	Header, 2 pin, 100-mil spacing, (36-pin strip), 0.100 inch x 2	PTC36SAAN	Sullins
2	Q1, Q2	Bipolar, PNP, xx-V, yy-mA, zz-W, SOT23	MMBT3906LT1	On Semi
1	R1	Resistor, chip, 0.5 W, 1%, 499 Ω , 2512	STD	STD
1	R11	Resistor, chip, 1/16 W, 1%, 24.9 k Ω , 603	STD	Vishay
1	R12	Resistor, chip, 1/16 W, 1%, 40.2 k Ω , 603	STD	Vishay
1	R13	Resistor, chip, 1/16 W, 1%, 49.9 k Ω , 603	STD	Vishay
2	R2, R3	Resistor, chip, 1/16 W, 5%, 10 k Ω , 603	STD	Vishay
2	R4, R5	Resistor, chip, 1/16 W, 1%, 1 k Ω , 603	STD	Vishay
1	R6	Resistor, chip, 1/16 W, 1%, 10 k Ω , 603	STD	Vishay
2	R7, R9	Resistor, chip, 1/16 W, 5%, 20 k Ω , 603	STD	Vishay
2	R8, R10	Resistor, chip, 1/10 W, 5%, 300 Ω , 805	STD	Vishay
1	S1	Switch, SPDT, slide, PC mount, 500 mA, 0.400 x 0.100 inch	09-03201-02	EAO
9	TP1, TP2, TP3, TP4, TP5, TP6, TP7, TP8, TP9	Test point, white, thru hole, 0.125 x 0.125 inch	5012	Keystone
4	TP10, TP11, TP12, TP13	Test point, SM, 0.150 x 0.090, 0.185 x 0.135 inch	5016	Keystone
0	TP14, TP15, TP16, TP17	Test point, 0.062 Hole, 0.250 inch	5012	Keystone
1	U1	0 to 12V Integrated FET Hot Swap, QFN-16	TPS2420RSA	TI
1	U2	0 to 12V Integrated FET Hot Swap, SO8[DDA]	TPS2421-1DDA	TI
1	U2	0 to 12V Integrated FET Hot Swap, SO8[DDA]	TPS2421-2DDA	TI
1	--	Shunt, 100-mil, black		

6 Board Outline

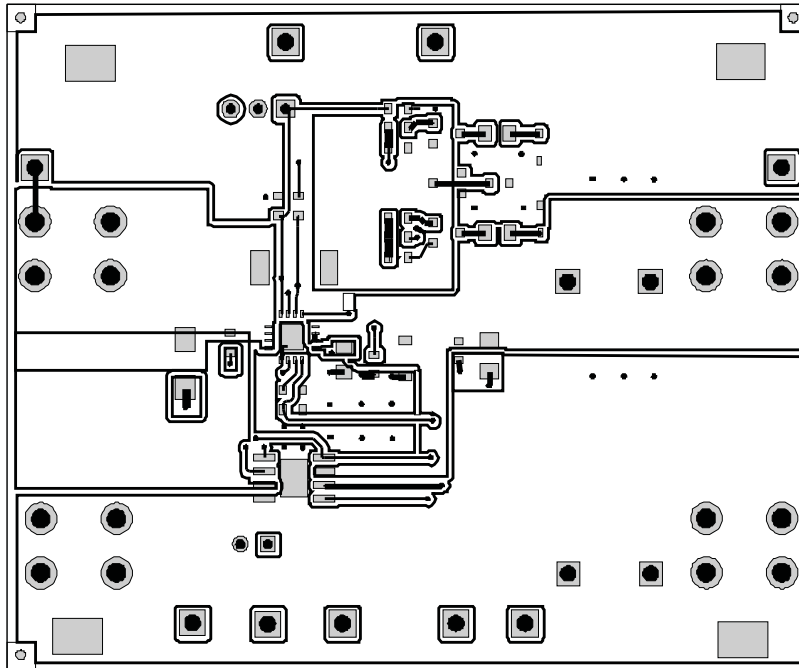

Figure 3. Board Outline (top)

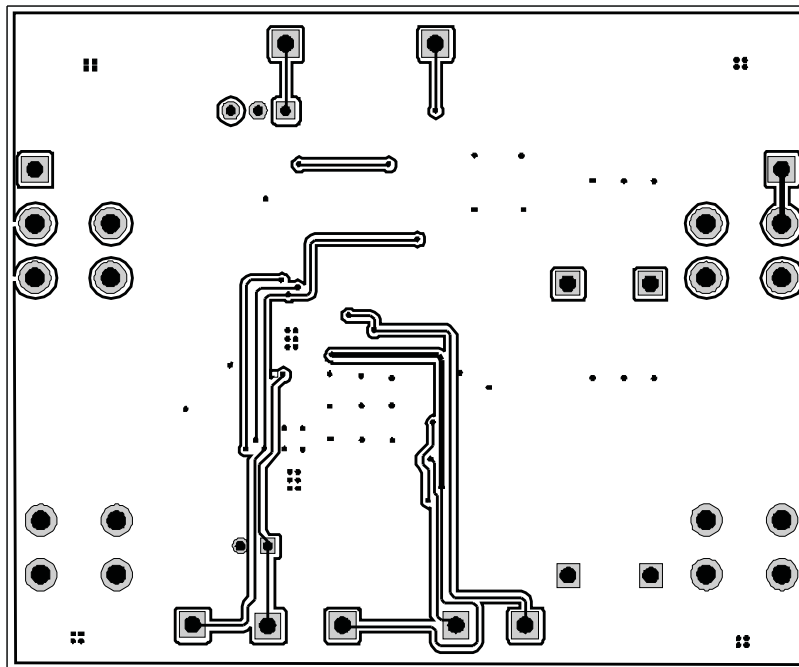

Figure 4. Board Outline (bottom)

6.1 Test Points

Test Points TP14, TP15, TP16, TP17, are not installed. These are placed on the board unmarked near Load and Load Return. This is a user option to hardwire additional capacitors, etc to the output.

Table 2. Test Points

TEST POINT	NAME	DESCRIPTION
TP1	VIN	Input voltage power supply
TP2	4.3 V REF	\$0.3 V reference
TP3	EN	Enable signal, high true
TP4	$\overline{\text{FLT}}$	Fault signal, low true
TP5	$\overline{\text{PG}}$	Power good signal, low true
TP6	IMON	Output current monitor, @@Volts / Amp
TP7	LATCH	Latch signal, high true, low for retry
TP8	VOUT	Output voltage
TP9	CT	Fault timer capacitor
TP10	GND	Scope ground test point
TP11	GND	Scope ground test point
TP12	GND	Scope ground test point
TP13	GND	Scope ground test point

6.2 Connectors

Table 3. Connectors

CONNECTOR	DESCRIPTION
J1	Main power input, VIN
J2	Main power ground, GND
J4	Load
J5	Load ground, GND

6.3 Jumpers

Jumper J6 is used to disconnect the LEDs for test measurement of TPS2420 quiescent current. This jumper is normally installed.

Table 4. Jumpers

JUMPER	DESCRIPTION
J3	TPS2420 only off = latch, on = retry
J6	Installed for normal operation

6.4 Switches

6.4.1 Enable Switch S1

The Enable slide switch turns on the hot plug controller to ramp the output voltage. When the switch is off, the output is off.

6.5 Indicators

- Green LED Indicator for Power Good (PG)
- Red LED Indicator for FAULT (FLT)

7 Equipment

7.1 Equipment Needed

7.1.1 6.1.1 Voltage Source

The input voltage source, VIN is a 20-V variable dc source at 10 A.

7.1.2 6.1.3 Oscilloscope

A digital oscilloscope can be used to monitor the test points. [Table 2](#) lists the test points.

7.1.3 6.1.4 Current Probe

A current probe is helpful to observe turn on characteristics of the external load.

7.1.4 6.1.5 Recommended Wire Gauge

Power is limited to 5 W; 18 gage wire minimum is recommended.

7.2 6.2 Equipment Supplied

The TPS242x Module configured with TPS2420/21 is supplied.

Table 5. EVM Configurations

EVALUATION MODULE	COMPONENT
HPA270EVM-001	TPS2420
HPA270EVM-002	TPS2421-1
HPA270EVM-003	TPS2420-2

8 Getting Started (example)

8.1 Equipment Connections

Reference [Figure 5](#) for equipment connections.

- Input power supply positive voltage to J1 and negative voltage to GND, J2. Connectors J1 and J2 can accept #6 ring or spade lugs.
- RC load at J4 and the load return at J5. The example here uses 220 μ F, 15 Ω .
- Scope to current probe to measure the load current.
- Scope the V_{OUT} - TP8, \overline{EN} - TP3, \overline{PG} - TP5.

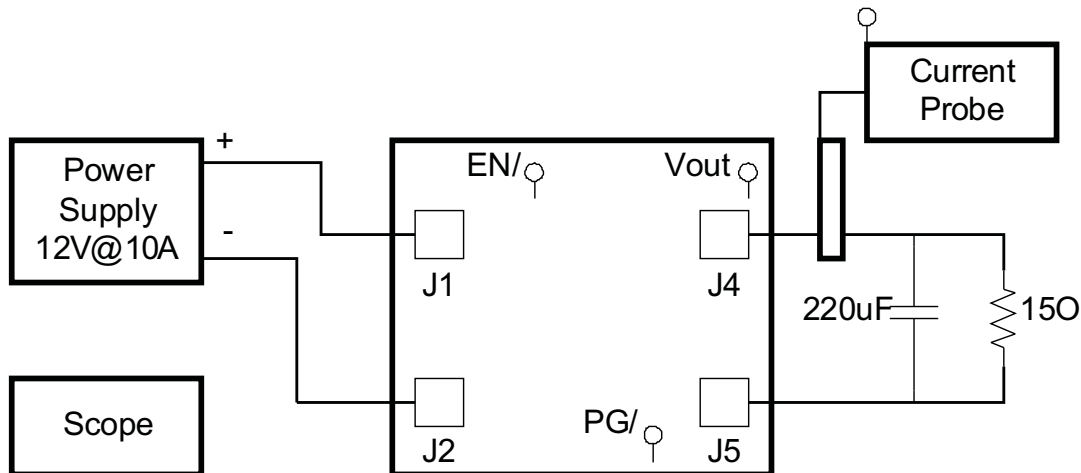

Note:

 Connects to Scope

Figure 5. Equipment Connections

8.2 Operation

- Turn on the power supply.
- Trigger the scope on \overline{EN} low going edge.
- Slide the \overline{EN} to the \overline{EN} position as screened on the circuit board.

8.3 Test Results

Observe waveforms similar to [Figure 6](#).

- The current to the load is not constant but increases after the initial inrush. Current is low initially because the voltage across the internal MOSFET is initially at its highest level and the controller is power limiting the MOSFET.

$$V_{PASS} = V_{IN} - V_{OUT}$$

$$P_{TPS2420} = V_{PASS} \times I_{OUT}$$

- Although the current limit, I_{FLT1} , is set to 4 A, the start up current never goes above 2.2 A because of the power limiting. However, 4 A is available to the steady state load when the MOSFET is fully enhanced.
- At the end of the capacitor charge time, the current drops to the dc level powering the resistive part of the load, about 0.8 A.
- Power Good (\overline{PG}) is true when the output voltage is within 0.3 V of the input voltage.

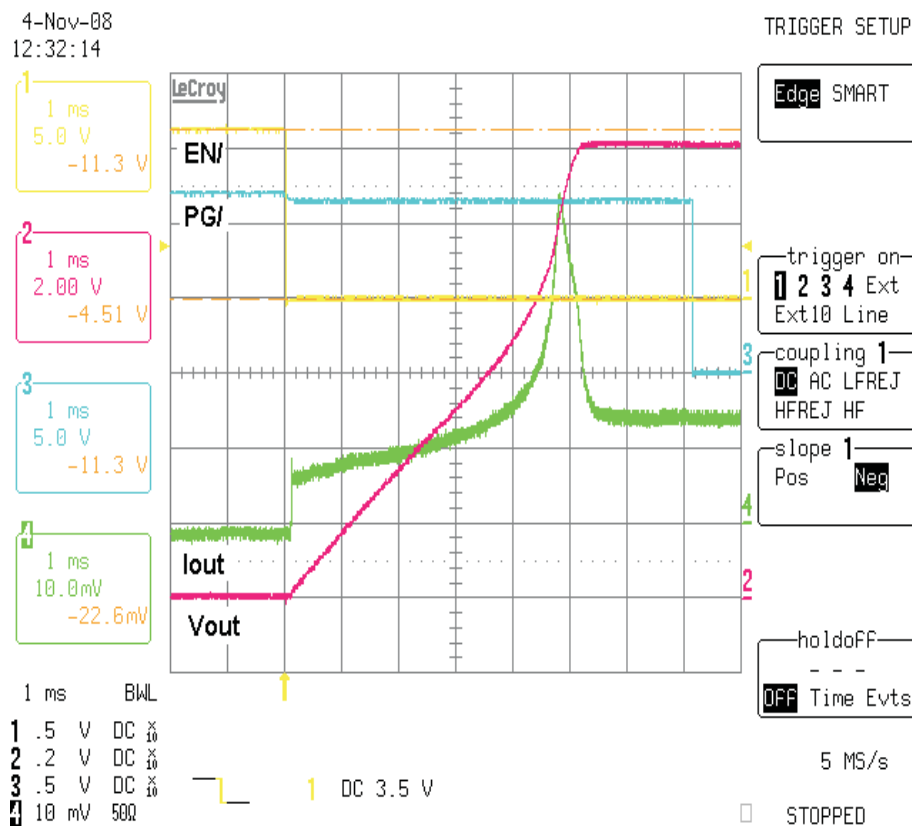

Figure 6. Example Scope Trace

EVALUATION BOARD/KIT IMPORTANT NOTICE

Texas Instruments (TI) provides the enclosed product(s) under the following conditions:

This evaluation board/kit is intended for use for **ENGINEERING DEVELOPMENT, DEMONSTRATION, OR EVALUATION PURPOSES ONLY** and is not considered by TI to be a finished end-product fit for general consumer use. Persons handling the product(s) must have electronics training and observe good engineering practice standards. As such, the goods being provided are not intended to be complete in terms of required design-, marketing-, and/or manufacturing-related protective considerations, including product safety and environmental measures typically found in end products that incorporate such semiconductor components or circuit boards. This evaluation board/kit does not fall within the scope of the European Union directives regarding electromagnetic compatibility, restricted substances (RoHS), recycling (WEEE), FCC, CE or UL, and therefore may not meet the technical requirements of these directives or other related directives.

Should this evaluation board/kit not meet the specifications indicated in the User's Guide, the board/kit may be returned within 30 days from the date of delivery for a full refund. **THE FOREGOING WARRANTY IS THE EXCLUSIVE WARRANTY MADE BY SELLER TO BUYER AND IS IN LIEU OF ALL OTHER WARRANTIES, EXPRESSED, IMPLIED, OR STATUTORY, INCLUDING ANY WARRANTY OF MERCHANTABILITY OR FITNESS FOR ANY PARTICULAR PURPOSE.**

The user assumes all responsibility and liability for proper and safe handling of the goods. Further, the user indemnifies TI from all claims arising from the handling or use of the goods. Due to the open construction of the product, it is the user's responsibility to take any and all appropriate precautions with regard to electrostatic discharge.

EXCEPT TO THE EXTENT OF THE INDEMNITY SET FORTH ABOVE, NEITHER PARTY SHALL BE LIABLE TO THE OTHER FOR ANY INDIRECT, SPECIAL, INCIDENTAL, OR CONSEQUENTIAL DAMAGES.

TI currently deals with a variety of customers for products, and therefore our arrangement with the user **is not exclusive.**

TI assumes **no liability for applications assistance, customer product design, software performance, or infringement of patents or services described herein.**

Please read the User's Guide and, specifically, the Warnings and Restrictions notice in the User's Guide prior to handling the product. This notice contains important safety information about temperatures and voltages. For additional information on TI's environmental and/or safety programs, please contact the TI application engineer or visit www.ti.com/esh.

No license is granted under any patent right or other intellectual property right of TI covering or relating to any machine, process, or combination in which such TI products or services might be or are used.

FCC Warning

This evaluation board/kit is intended for use for **ENGINEERING DEVELOPMENT, DEMONSTRATION, OR EVALUATION PURPOSES ONLY** and is not considered by TI to be a finished end-product fit for general consumer use. It generates, uses, and can radiate radio frequency energy and has not been tested for compliance with the limits of computing devices pursuant to part 15 of FCC rules, which are designed to provide reasonable protection against radio frequency interference. Operation of this equipment in other environments may cause interference with radio communications, in which case the user at his own expense will be required to take whatever measures may be required to correct this interference.

EVM WARNINGS AND RESTRICTIONS

It is important to operate this EVM within the input voltage range of and the output voltage range of 3 VDC to 18 VDC.

Exceeding the specified input range may cause unexpected operation and/or irreversible damage to the EVM. If there are questions concerning the input range, please contact a TI field representative prior to connecting the input power.

Applying loads outside of the specified output range may result in unintended operation and/or possible permanent damage to the EVM. Please consult the EVM User's Guide prior to connecting any load to the EVM output. If there is uncertainty as to the load specification, please contact a TI field representative.

During normal operation, some circuit components may have case temperatures greater than 85°C. The EVM is designed to operate properly with certain components above as long as the input and output ranges are maintained. These components include but are not limited to linear regulators, switching transistors, pass transistors, and current sense resistors. These types of devices can be identified using the EVM schematic located in the EVM User's Guide. When placing measurement probes near these devices during operation, please be aware that these devices may be very warm to the touch.

Mailing Address: Texas Instruments, Post Office Box 655303, Dallas, Texas 75265
Copyright © 2009, Texas Instruments Incorporated

IMPORTANT NOTICE AND DISCLAIMER

TI PROVIDES TECHNICAL AND RELIABILITY DATA (INCLUDING DATASHEETS), DESIGN RESOURCES (INCLUDING REFERENCE DESIGNS), APPLICATION OR OTHER DESIGN ADVICE, WEB TOOLS, SAFETY INFORMATION, AND OTHER RESOURCES "AS IS" AND WITH ALL FAULTS, AND DISCLAIMS ALL WARRANTIES, EXPRESS AND IMPLIED, INCLUDING WITHOUT LIMITATION ANY IMPLIED WARRANTIES OF MERCHANTABILITY, FITNESS FOR A PARTICULAR PURPOSE OR NON-INFRINGEMENT OF THIRD PARTY INTELLECTUAL PROPERTY RIGHTS.

These resources are intended for skilled developers designing with TI products. You are solely responsible for (1) selecting the appropriate TI products for your application, (2) designing, validating and testing your application, and (3) ensuring your application meets applicable standards, and any other safety, security, regulatory or other requirements.

These resources are subject to change without notice. TI grants you permission to use these resources only for development of an application that uses the TI products described in the resource. Other reproduction and display of these resources is prohibited. No license is granted to any other TI intellectual property right or to any third party intellectual property right. TI disclaims responsibility for, and you fully indemnify TI and its representatives against any claims, damages, costs, losses, and liabilities arising out of your use of these resources.

TI's products are provided subject to [TI's Terms of Sale](#), [TI's General Quality Guidelines](#), or other applicable terms available either on ti.com or provided in conjunction with such TI products. TI's provision of these resources does not expand or otherwise alter TI's applicable warranties or warranty disclaimers for TI products. Unless TI explicitly designates a product as custom or customer-specified, TI products are standard, catalog, general purpose devices.

TI objects to and rejects any additional or different terms you may propose.

Copyright © 2026, Texas Instruments Incorporated

Last updated 10/2025