

# TUSB1002A USB3.2 10Gbps Dual-Channel Linear Redriver

## 1 Features

- Supports USB3.2 x1 SuperSpeed (5Gbps) and SuperSpeedPlus (10Gbps)
- Supports PCI express Gen3, SATA express, and SATA Gen3
- Ultra low-power architecture:
  - Disconnect U2, U3: < 1.9mW
  - Shutdown: < 700µW
- Adjustable voltage output swing linear range up to 1200mVpp
- No host or device side requirement
- 16 settings for up to 16dB at 10Gbps of linear equalization
- Adjustable DC equalization gain
- Hot-plug capable
- Pin-to-pin compatible with LVPE502A and LVPE512 USB 3.0 redriver
- Pin-to-pin compatible with TUSB1002 redriver
- Temperature range: 0°C to 70°C (commercial) and –40°C to 85°C (industrial)
- ±5kV HBM ESD
- Available in single 3.3V supply.
- Available in 4mm × 4mm VQFN

## 2 Applications

- [Notebook and desktop PC](#)
- [TVs](#)
- [Tablets](#)
- [Cell phones](#)
- [Active cable](#)
- [Docking stations](#)

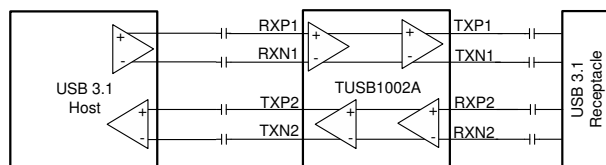

**Simplified Schematic**

## 3 Description

The TUSB1002A is the industry's first dual-channel USB 3.2 x1 SuperSpeedPlus (SSP) redriver and signal conditioner. The device offers low power consumption on a 3.3V supply with its ultra-low-power architecture. The device supports the USB3.2 low power modes which further reduces idle power consumption.

The TUSB1002A implements a linear equalizer, supporting up to 16dB of loss due to inter-symbol interference (ISI). When USB signals travel across a PCB or cable, signal integrity degrades due to loss and inter-symbol interference. The linear equalizer compensates for the channel loss, and thereby, extends the channel length and enables systems to pass USB compliance. The dual lane implementation and small package size provides flexibility in the placement of the TUSB1002A in the USB3.2 path.

The TUSB1002A is available in either a 24-pin 4mm × 4mm VQFN. It is also available in a commercial grade (TUSB1002A) or industrial grade (TUSB1002AI).

### Device Information

PART NUMBER <sup>(1)</sup>	TEMPERATURE	PACKAGE	PACKAGE SIZE <sup>(2)</sup>
TUSB1002A	T <sub>A</sub> = 0°C to 70°C	RGE (VQFN, 24)	4mm × 4mm
TUSB1002AI	T <sub>A</sub> = –40°C to 85°C		

- (1) For all available packages, see [Section 10](#).
- (2) The package size (length × width) is a nominal value and includes pins, where applicable.



## Table of Contents

<b>1 Features</b> .....	1	6.6 U1 Mode.....	18
<b>2 Applications</b> .....	1	6.7 U2/U3 Mode.....	18
<b>3 Description</b> .....	1	<b>7 Application and Implementation</b> .....	19
<b>4 Pin Configuration and Functions</b> .....	3	7.1 Application Information.....	19
<b>5 Specifications</b> .....	5	7.2 Typical USB3.2 Application.....	19
5.1 Absolute Maximum Ratings.....	5	7.3 Typical SATA, PCIe and SATA Express Application.....	23
5.2 ESD Ratings.....	5	7.4 Power Supply Recommendations.....	26
5.3 Recommended Operating Conditions.....	5	7.5 Layout.....	26
5.4 Thermal Information.....	5	<b>8 Device and Documentation Support</b> .....	28
5.5 Electrical Characteristics.....	6	8.1 Receiving Notification of Documentation Updates....	28
5.6 Timing Requirements.....	8	8.2 Support Resources.....	28
5.7 Switching Characteristics.....	8	8.3 Trademarks.....	28
5.8 Typical Characteristics.....	11	8.4 Electrostatic Discharge Caution.....	28
<b>6 Detailed Description</b> .....	14	8.5 Glossary.....	28
6.1 Overview.....	14	<b>9 Revision History</b> .....	28
6.2 Functional Block Diagram.....	14	<b>10 Mechanical, Packaging, and Orderable Information</b> .....	29
6.3 Feature Description.....	15		
6.4 Device Functional Modes.....	18		
6.5 U0 Mode.....	18		

## 4 Pin Configuration and Functions

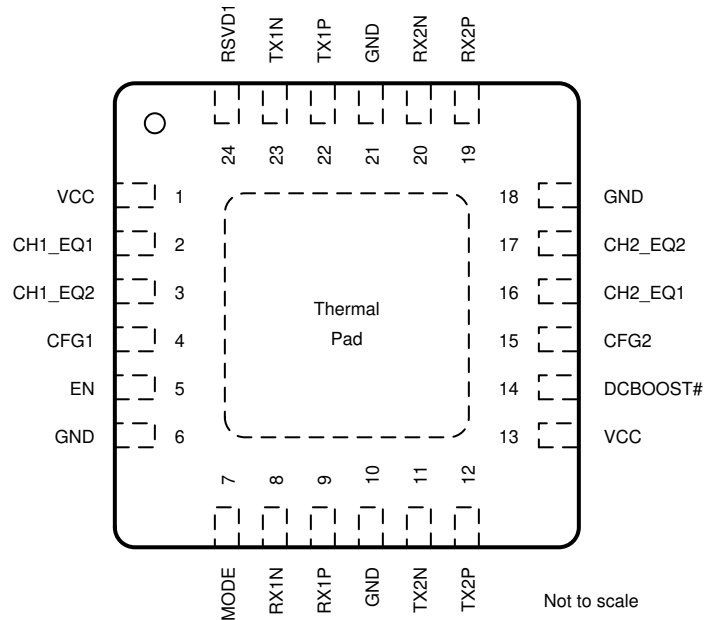

**Figure 4-1. RGE Package, 24-Pin VQFN (Top View)**

**Table 4-1. Pin Functions**

PIN		TYPE	INTERNAL PULLUP PULLDOWN	DESCRIPTION
NAME	NO.			
RX1P	9	90Ω Differential Input	—	Differential input for SuperSpeed (SS) and SuperSpeedPlus (SSP) positive signals for Channel 1
RX1N	8			Differential input for SuperSpeed (SS) and SuperSpeedPlus (SSP) negative signals for Channel 1
RX2P	19	90Ω Differential Input	—	Differential input for SuperSpeed (SS) and SuperSpeedPlus (SSP) positive signals for Channel 2
RX2N	20			Differential input for SuperSpeed (SS) and SuperSpeedPlus (SSP) negative signals for Channel 2.
TX1P	22	90Ω Differential Output	—	Differential output for SuperSpeed (SS) and SuperSpeedPlus (SSP) positive signals for Channel 1.
TX1N	23			Differential output for SuperSpeed (SS) and SuperSpeedPlus (SSP) negative signals for Channel 1.
TX2P	12	90Ω Differential Output	—	Differential output for SuperSpeed (SS) and SuperSpeedPlus (SSP) positive signals for Channel 2.
TX2N	11			Differential output for SuperSpeed (SS) and SuperSpeedPlus (SSP) negative signals for Channel 2.
CH1_EQ1	2	I (4-level)	PU (approx 45K) PD (approx 95K)	CH1_EQ1. Configuration pin used to control Rx EQ level for RX1P/N. The state of this pin is sampled after the rising edge of EN. Refer to <a href="#">Figure 5-2</a> for details of timing. This pin along with CH1_EQ2 allows for up to 16 equalization settings.
CH1_EQ2	3	I (4-level)		CH1_EQ2. Configuration pin used to control Rx EQ level for RX1P/N. The state of this pin is sampled after the rising edge of EN. Refer to <a href="#">Figure 5-2</a> for details of timing. This pin along with CH1_EQ1 allows for up to 16 equalization settings.
CH2_EQ1	16	I (4-level)		CH2_EQ1. Configuration pin used to control Rx EQ level for RX2P/N. The state of this pin is sampled after the rising edge of EN. Refer to <a href="#">Figure 5-2</a> for details of timing. This pin along with CH2_EQ2 allows for up to 16 equalization settings.
CH2_EQ2	17	I (4-level)		CH2_EQ2. Configuration pin used to control Rx EQ level for RX2P/N. The state of this pin is sampled after the rising edge of EN. Refer to <a href="#">Figure 5-2</a> for details of timing. This pin along with CH2_EQ1 allows for up to 16 equalization settings.
EN	5	I (2-level)	PU (approx 400 K)	EN. Places TUSB1002A into shutdown mode when asserted low. Normal operation when pin is asserted high. When in shutdown, TUSB1002A's receiver terminations are high impedance and tx/rx channels are disabled.

**Table 4-1. Pin Functions (continued)**

PIN		TYPE	INTERNAL PULLUP PULLDOWN	DESCRIPTION
NAME	NO.			
CFG1	4	I (4-level)	PU (approx 45K) PD (approx 95K)	CFG1. This pin along with CFG2 selects the VOD linearity range and DC gain for both channels 1 and 2. The state of this pin is sampled after the rising edge of EN. Refer to <a href="#">Figure 5-2</a> for details of timing. Refer to <a href="#">Table 6-3</a> for VOD linearity range and DC gain options.
CFG2	15	I (4-level)	PU (approx 45K) PD (approx 95K)	CFG2. This pin along with CFG1 sets the VOD linearity range and DC gain for both channels 1 and 2. The state of this pin is sampled after the rising edge of EN. Refer to <a href="#">Figure 5-2</a> for details of timing. Refer to <a href="#">Table 6-3</a> for VOD linearity range and DC gain options.
MODE	7	I (4-level)	PU (approx 45 K) PD (approx 95K)	MODE. This pin is for selecting different modes of operation. The state of this pin is sampled after the rising edge of EN. Refer to <a href="#">Figure 5-2</a> for details of timing. 0 = Basic Redriver Mode. R = PCIe / Test Mode. PCIe Mode and TI Internal use only F = USB3.2 x1 Dual Channel Operation enabled (TUSB1002A normal mode). 1 = USB3.2 x1 Single-channel operation.
RSVD1	24	O	—	RSVD1. Under normal operation, this pin is driven low by TUSB1002A. Recommend leaving this pin unconnected on PCB.
DCBOOST #	14	I (2-level)	PU (approx 400 K)	DCBOOST#. This pin when asserted low increases the DC Gain level defined in <a href="#">Table 6-3</a> by +1dB unless already at +2dB. If DC Gain level defined in <a href="#">Table 6-3</a> is already at +2dB, then asserting this pin low will not change the DC Gain level. This pin can be left unconnected if this function is not needed. 1 = DC Gain defined by <a href="#">Table 6-3</a> . 0 = DC Gain defined by <a href="#">Table 6-3</a> is increased by +1dB.
VCC	1, 13	Power	—	3.3V (±10%) Supply.
GND	6, 10, 18, 21	GND	—	Ground
Thermal pad			—	Thermal pad. Recommend connecting to a solid ground plane.

## 5 Specifications

### 5.1 Absolute Maximum Ratings

over operating free-air temperature range (unless otherwise noted)<sup>(1)</sup>

		MIN	MAX	UNIT
Supply Voltage Range	V <sub>CC</sub>	-0.3	4	V
Voltage Range on I/O pins	Differential voltage for RX1P/N and RX2P/N	-2.5	2.5	V
	Voltage at RX pins	-0.5	4	V
	Voltage on Control pins	-0.5	4	V
T <sub>stg</sub>	Storage temperature	-65	150	°C

- (1) Stresses beyond those listed under *Absolute Maximum Rating* may cause permanent damage to the device. These are stress ratings only, which do not imply functional operation of the device at these or any other conditions beyond those indicated under *Recommended Operating Condition*. Exposure to absolute-maximum-rated conditions for extended periods may affect device reliability.

### 5.2 ESD Ratings

			VALUE	UNIT
V <sub>(ESD)</sub>	Electrostatic discharge	Human body model (HBM), per ANSI/ESDA/ JEDEC JS-001, all pins <sup>(1)</sup>	±5000	V
		Charged device model (CDM), per JEDEC specification JESD22-C101, all pins <sup>(2)</sup>	±1500	

- (1) JEDEC document JEP155 states that 500V HBM allows safe manufacturing with a standard ESD control process.  
(2) JEDEC document JEP157 states that 250V CDM allows safe manufacturing with a standard ESD control process.

### 5.3 Recommended Operating Conditions

over operating free-air temperature range (unless otherwise noted)

		MIN	NOM	MAX	UNIT
V <sub>CC</sub>	Supply voltage	3	3.3	3.6	V
V <sub>PSN</sub>	Supply noise on V <sub>CC</sub> pins			100	mV
T <sub>A</sub>	TUSB1002A Ambient temperature	0		70	°C
	TUSB1002AI Ambient temperature	-40		85	°C
T <sub>J</sub>	TUSB1002A Junction temperature	0		105	°C
	TUSB1002AI Junction temperature	-40		105	°C

### 5.4 Thermal Information

THERMAL METRIC <sup>(1)</sup>		TUSB1002A	UNIT
		RGE (VQFN)	
		24 PINS	
R <sub>θJA</sub>	Junction-to-ambient thermal resistance	38.5	°C/W
R <sub>θJC(top)</sub>	Junction-to-case (top) thermal resistance	41.6	°C/W
R <sub>θJB</sub>	Junction-to-board thermal resistance	16.3	°C/W
Ψ <sub>JT</sub>	Junction-to-top characterization parameter	1.0	°C/W
Ψ <sub>JB</sub>	Junction-to-board characterization parameter	16.4	°C/W
R <sub>θJC(bot)</sub>	Junction-to-case (bottom) thermal resistance	6.9	°C/W

- (1) For more information about traditional and new thermal metrics, see the [Semiconductor and IC Package Thermal Metrics](#) application note.

## 5.5 Electrical Characteristics

over operating free-air temperature and voltage range (unless otherwise noted)

PARAMETER		TEST CONDITIONS	MIN	TYP	MAX	UNIT
<b>POWER</b>						
$P_{U0\_SSP\_1200mV}$	Power under USB3.1 operation in U0 operating at SuperSpeedPlug datarate with linear range set to 1200mV.	At 10Gbps; $V_{CC} = 3.3V$ ; EN = 1; Pattern = CP9; $V_{OD} = 1200mVpp$		330		mW
$P_{U0\_SSP\_1000mV}$	Power under USB3.1 operation in U0 operating at SuperSpeedPlug datarate with linear range set to 1000mV.	At 10Gbps; $V_{CC} = 3.3V$ ; EN = 1; Pattern = CP9; $V_{OD} = 1000mVpp$		310		mW
$P_{U0\_SSP\_900mV}$	Power under USB3.1 operation in U0 operating at SuperSpeedPlug datarate with linear range set to 900mV.	At 10Gbps; $V_{CC} = 3.3V$ ; EN = 1; Pattern = CP9; $V_{OD} = 900mVpp$		295		mW
$P_{U1}$	Power in U1 with linear range set to 1200mV.	In U1; $V_{CC} = 3.3V$ ; EN = 1; $V_{OD} = 1200mVpp$		330		mW
$P_{U2U3}$	Power when in U2/U3 state.	$V_{CC} = 3.3V$ ; EN = 1; Both channels in U2/U3;		1.5		mW
$P_{DISCONNECT\_NONE}$	Power when no USB device detected on both TX1P/N and TX2P/N.	$V_{CC} = 3.3V$ ; EN = 1; RX1 and RX2 termination disabled;		1.9		mW
$P_{DISCONNECT\_ONE}$	Power when a single USB device detected on either TX1P/N or TX2P/N.	$V_{CC} = 3.3V$ ; EN = 1; Either RX1 or RX2 termination enabled but not both enabled;		1.9		mW
$P_{SHUTDOWN}$	Shutdown power when EN = 0.	$V_{CC} = 3.3V$ ; EN = 0;		0.7		mW
<b>4-level Inputs (CFG[2:1], MODE, CH1_EQ[2:1], CH2_EQ[2:1])</b>						
$V_{TH}$	Threshold "0" / "R"	$V_{CC} = 3.3V$		0.55		V
	Threshold "R" / "F"	$V_{CC} = 3.3V$		1.65		V
	Threshold "F" / "1"	$V_{CC} = 3.3V$		2.8		V
$I_{IH}$	High-level input current	$V_{CC} = 3.6V$ ; $V_{IN} = 3.6V$	20		80	$\mu A$
$I_{IL}$	Low-level input current	$V_{CC} = 3.6V$ ; $V_{IN} = 0V$	-160		-40	$\mu A$
$R_{PU}$	Internal pullup resistance			45		k $\Omega$
$R_{PD}$	Internal pulldown resistance			95		k $\Omega$
<b>EN, DCBOOST#</b>						
$V_{IH}$	High-level input voltage	$V_{CC} = 3.3V$	1.7		3.6	V
$V_{IL}$	Low-level input voltage	$V_{CC} = 3.3V$	0		0.7	V
$I_{IH}$	High-level input current	$V_{CC} = 3.6V$ ; $V_{IN} = 3.6V$	-10		10	$\mu A$
$I_{IL}$	Low-level input current	$V_{CC} = 3.6V$ ; $V_{IN} = 0V$	-15		15	$\mu A$
$R_{PU\_EN}$	Internal pullup resistance for EN and DCBOOST#			400		k $\Omega$
<b>USB3.1 Receiver Interface (RX1P/N and RX2P/N)</b>						
$R_{L\_100MHz}$	Rx Differential return loss at 100MHz to 2.5GHz	SDD11 100MHz to 2.5GHz at 90 $\Omega$		-18		dB
$R_{L\_5GHz}$	Rx Differential return loss at 5GHz	SDD11 5GHz at 90 $\Omega$		-14		dB
$R_{L\_10GHz}$	Rx Differential return loss from 5 to 10GHz	SDD11 5GHz to 10 GHz at 90 $\Omega$		-6		dB
$R_{L\_CM}$	Rx common mode return loss	SCC11 0.5 to 5 GHz at 90 $\Omega$		-12		dB
X-Talk	Differential crosstalk between TX and RX signal pairs			-50		dB
$E_{ACGAIN\_5GHz}$	Max AC Equalization Gain	50mVpp CP10 at 5GHz; $V_{CC} = 3.3V$ ;		16		dB

## 5.5 Electrical Characteristics (continued)

over operating free-air temperature and voltage range (unless otherwise noted)

PARAMETER		TEST CONDITIONS	MIN	TYP	MAX	UNIT
E <sub>DC_GAIN0</sub>	DC Gain at 0dB setting	200mVpp VID at 100MHz; 1200mV Linear Range Setting;		.7		dB
E <sub>DC_GAIN1</sub>	DC Gain at 1dB setting	200mVpp VID at 100MHz; 1200mV Linear Range Setting;		1.6		dB
E <sub>DC_GAIN2</sub>	DC Gain at 2dB setting	200mVpp VID at 100MHz; 1000mV Linear Range Setting;		2.3		dB
E <sub>DC_GAIN-1</sub>	DC Gain at -1dB setting	200mVpp VID at 100MHz; 1200mV Linear Range Setting;		-0.25		dB
V <sub>DIFF_IN</sub>	Input differential peak-peak voltage swing range			1200		mV
V <sub>RX-DC-CM</sub>	RX DC common mode voltage			0		V
R <sub>RX-DC-CM</sub>	RX DC common mode impedance	Measured at connector; Present when USB Device detected on TXP/N;	18		30	Ω
R <sub>RX-DC-DIFF</sub>	RX DC differential impedance	Measured at connector; Present when USB Device detected on TXP/N;	72		120	Ω
Z <sub>RX-DC-DIFF</sub>	DC Input CM Input ImpedanceV > 0 during RESET or power down.	1. Rx DC CM Impedance with Rx terminations not powered. 2. Measured over the range 0 - 500mV with respect to GND. 3. Only DC input CM Input impedanceV > 0 is specified.	35			kΩ
V <sub>RX-SIGNAL-DET</sub>	Input differential peak-to-peak signal detect assert level	At 10Gbps; No loss input channel and PRBS7 pattern.		85		mV
V <sub>RX-IDLE-DET</sub>	Input differential peak-to-peak signal detect deassert level	At 10Gbps; No loss input channel and PRBS7 pattern.		60		mV
V <sub>RX-LFPS-DET</sub>	LFPS detect threshold.	Below min is squelched	100		310	mV
V <sub>RX-CM-AC-P</sub>	Peak RX AC common mode voltage	Measured at package pin.			150	mV
<b>USB3.1 Transmitter Interface (TX1P/N and TX2P/N)</b>						
R <sub>L_TX_100MHz</sub>	Tx Differential return loss at 100MHz	SDD22 100MHz - 2.5GHz at 90Ω		-20		dB
R <sub>L_TX_2.5GHz</sub>	Tx Differential return loss at 5GHz	SDD22 5GHz at 90Ω		-16		dB
R <sub>L_TX_10GHz</sub>	Tx Differential return loss from 5 to 10GHz	SDD22 5GHz to 10 GHz at 90Ω		-8.5		dB
R <sub>L_TX_CM</sub>	Tx common mode return loss	SCC22 0.5 to 5 GHz at 90Ω		-6.7		dB
V <sub>TX-DIFFPP-1200</sub>	Differential peak-to-peak TX voltage swing linear dynamic range at 100MHz	1200mVpp setting; 100MHz; Measured at -1dB compression point = 20 log(VOD/VOD_linear)		1000		mV
	Differential peak-to-peak TX voltage swing linear dynamic range at 5GHz	1200mVpp setting; 5GHz; Measured at -1dB compression point = 20 log(VOD/VOD_linear)		1300		mV
V <sub>TX-DIFFPP-1000</sub>	Differential peak-to-peak TX voltage swing linear dynamic range at 100MHz	1000mVpp setting; 100MHz; Measured at -1dB compression point = 20 log(VOD/VOD_linear)		900		mV
	Differential peak-to-peak TX voltage swing linear dynamic range at 5GHz	1000mVpp setting; 5GHz; Measured at -1dB compression point = 20 log(VOD/VOD_linear)		1150		mV
V <sub>TX-DIFFPP-900</sub>	Differential peak-to-peak TX voltage swing linear dynamic range at 100MHz	900mVpp setting; 100MHz; Measured at -1dB compression point = 20 log(VOD/VOD_linear)		800		mV
	Differential peak-to-peak TX voltage swing linear dynamic range at 5GHz	900mVpp setting; 5GHz; Measured at -1dB compression point = 20 log(VOD/VOD_linear)		1000		mV

## 5.5 Electrical Characteristics (continued)

over operating free-air temperature and voltage range (unless otherwise noted)

PARAMETER		TEST CONDITIONS	MIN	TYP	MAX	UNIT
$V_{TX-RCV-DETECT}$	Amount of voltage change allowed during Rx Detection.	Measured at package pins.			600	mV
$V_{TX-CM-IDLE-DELTA}$	Transmitter idle common mode voltage change U2/U3 state.	Max allowed instantaneous common-mode voltage at connector side of AC coupling capacitor. This is an absolute voltage spec referenced to the receive side termination ground.	-600		600	mV
$V_{TX-DC-CM}$	TX DC common mode voltage	1200mVpp linear range setting;	0	1.85	2.05	V
$V_{TX-CM-AC-PP-ACTIVE}$	Transmitter AC common mode peak-peak voltage in U0. Maximum mismatch from TXP+TXN for both time and amplitude.	1200mVpp linear setting; CHx_EQ setting matches input channel insertion loss;			116	mV
$V_{TX-IDLE-DIFF-AC-PP}$	AC electrical idle differential peak-to-peak output voltage		0		10	mV
$V_{TX-CM-DC-ACTIVE-IDLE-DELTA}$	Absolute DC common mode voltage between U1 and U0				200	mV
$R_{TX-DC-CM}$	TX DC common mode impedance		18		30	$\Omega$
$R_{TX-DC-DIFF}$	TX DC differential impedance		72		120	$\Omega$
$I_{TX-SHORT}$	Transmitter short-circuit current limit.				107	mA
$C_{AC-COUPLING}$	External AC coupling capacitor on differential pairs.		75		265	nF

## 5.6 Timing Requirements

over operating free-air temperature and voltage range (unless otherwise noted)

		MIN	NOM	MAX	UNIT
$t_{d\_pg}$	Internal power good asserted high when $V_{CC}$ is at 2.5V			5	$\mu$ s
$t_{CFG\_SU}$	CFG <sup>(1)</sup> pins setup before internal Reset <sup>(2)</sup> high	0			$\mu$ s
$t_{CFG\_HD}$	CFG <sup>(1)</sup> pins hold after internal Reset <sup>(2)</sup> high	500			$\mu$ s
$t_{VCC\_RAMP}$	$V_{CC}$ supply ramp requirement	0.1		50	ms

(1) Following pins comprise CFG pins: MODE, CFG[2:1], CH1\_EQ[2:1], CH2\_EQ[2:1]

(2) Internal reset is the logical AND of EN pin and internal power good.

## 5.7 Switching Characteristics

over operating free-air temperature and voltage range (unless otherwise noted)

PARAMETER		TEST CONDITIONS	MIN	TYP	MAX	UNIT
$t_{IDLEEntry}$	Delay from U0 to electrical idle	$V_{CC} = 3.0V$ ; EN = 1; See <a href="#">Figure 5-1</a>			150	ps
$t_{IDLEEntry\_U1}$	U1 exit time. Break in electrical idle to transmission of LFPS.	$V_{CC} = 3.0V$ ; EN = 1; See <a href="#">Figure 5-1</a>			150	ps
$t_{IDLEEntry\_U2U3}$	U2/U3 exit time; Break in electrical idle to transmission of LFPS	$V_{CC} = 3.0V$ ; EN = 1; See <a href="#">Figure 5-1</a>			6	$\mu$ s
$t_{DIFF\_DLY}$	Differential propagation delay	$V_{CC} = 3.0V$ ; EN = 1;			150	ps
$t_{PWRUP\_ACTIV E}$	Time from assertion of EN to device active and performing Rx.Detect on both ports	$V_{CC} = 3.0V$ ; EN = 1;			8	ms
$t_{TX\_RISE\_FALL}$	Transmitter rise/fall time	$V_{CC} = 3.3V$ ; EN = 1; 10Gbps; 20% to 80% of differential output; 1200mVpp linear range setting; Fast Input rise/fall time;		27		ps

### 5.7 Switching Characteristics (continued)

over operating free-air temperature and voltage range (unless otherwise noted)

PARAMETER		TEST CONDITIONS	MIN	TYP	MAX	UNIT
$t_{RF\_MISMATCH}$	Transmitter rise/fall mismatch	$V_{CC} = 3.3V$ ; EN = 1; 10Gbps; 20% to 80% of differential output; 1200mVpp linear range setting; 1000mVpp VID		.6		ps
$t_{TX\_DJ}$	Transmitter residual deterministic jitter	$V_{CC} = 3.3V$ ; EN = 1; 10Gbps; 1200mVpp linear range setting; Input channel loss of 12dB; Output channel loss of 1.5dB; Optimized EQ;		0.05		UI

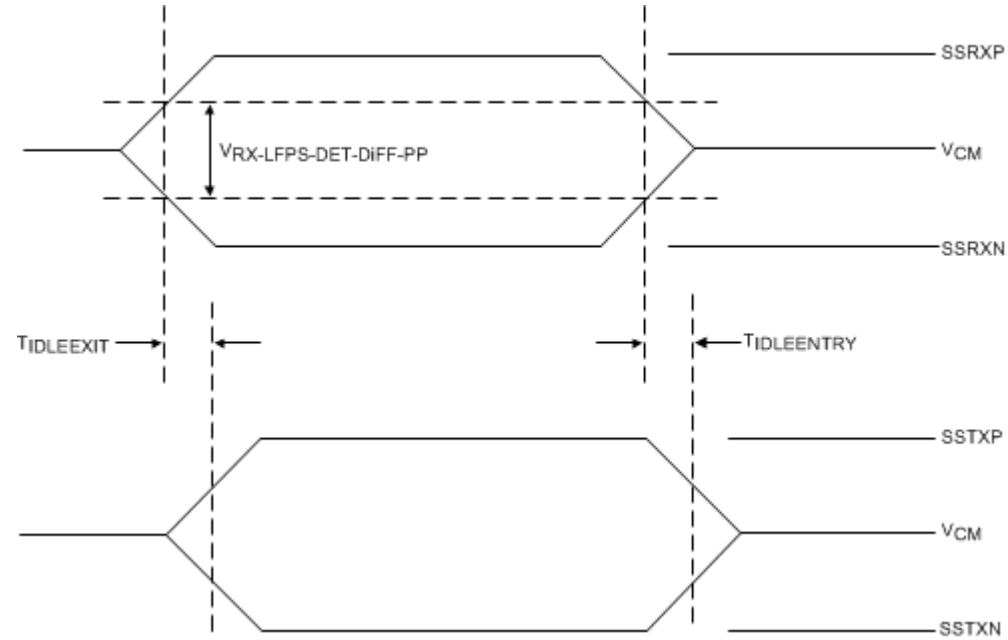

**Figure 5-1. Idle Entry and Exit Latency**

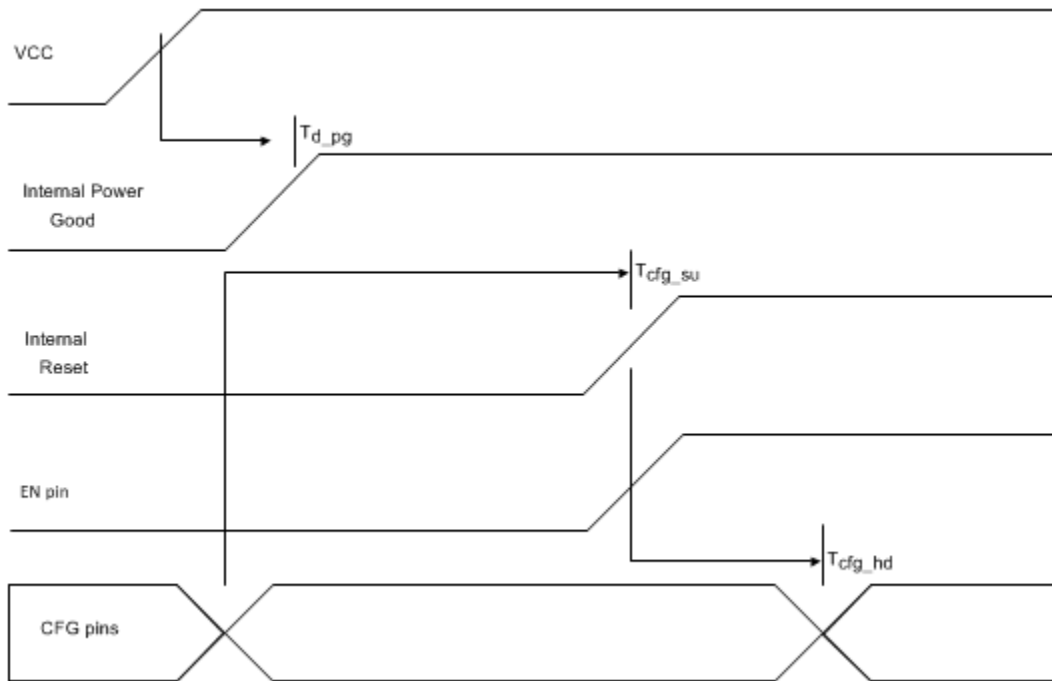
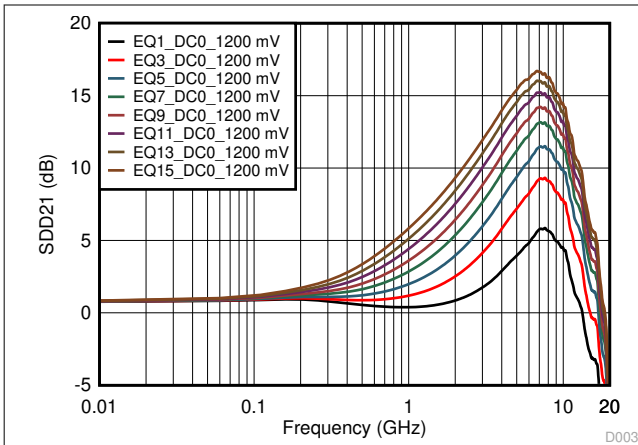

Figure 5-2. Power-Up Diagram

### 5.8 Typical Characteristics

$V_{CC} = 3.3V$ ,  $25^{\circ}C$ ,  $200mV_{pp}$   $V_{ID}$  sine wave,  $Z_O = 100\Omega$ , RGE package



**Figure 5-3. 1200mV DC0 Gain Odd EQ Settings Curves**

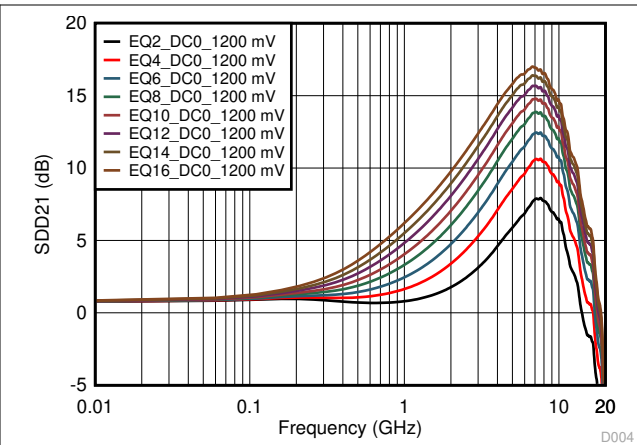

**Figure 5-4. 1200mV DC0 Even EQ Settings Curves**

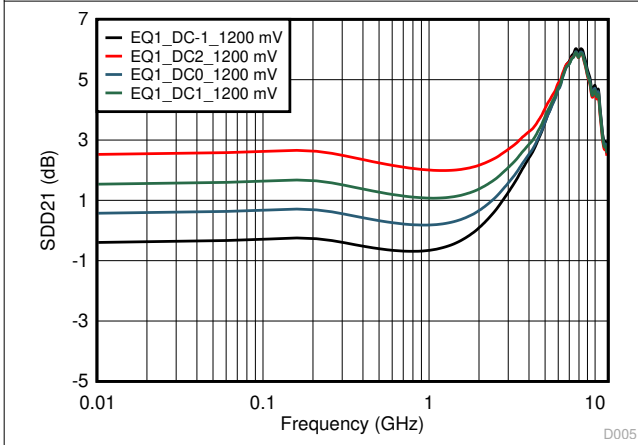

**Figure 5-5. 1200mV DC Gain Adjustments Curves**

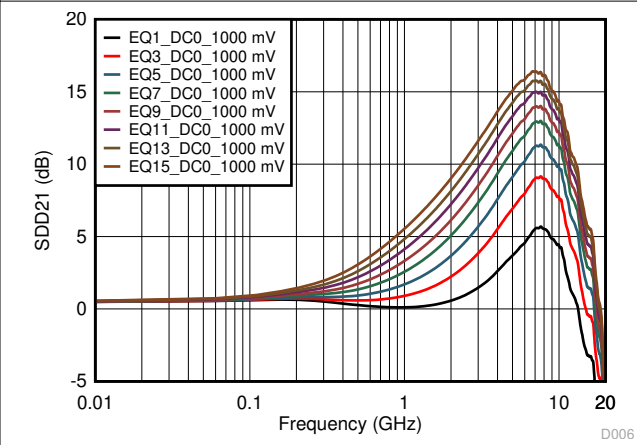

**Figure 5-6. 1000mV DC0 Gain Odd EQ Settings Curves**

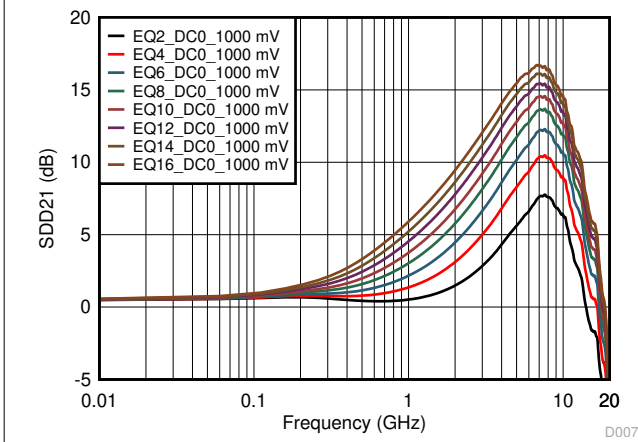

**Figure 5-7. 1000mV DC0 Gain Even EQ Settings Curves**

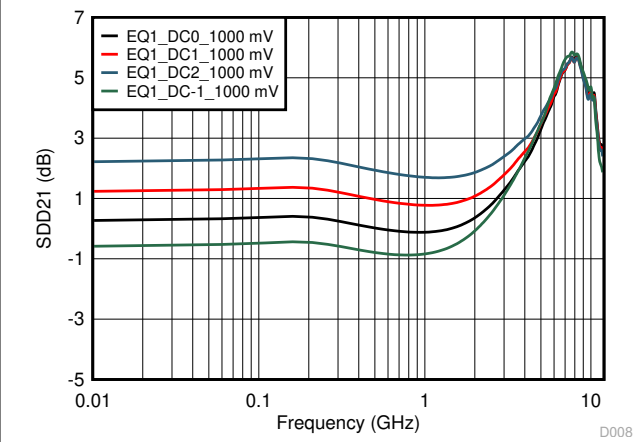

**Figure 5-8. 1000mV DC Gain Adjustments Curves**

### 5.8 Typical Characteristics (continued)

$V_{CC} = 3.3V$ ,  $25^{\circ}C$ ,  $200mV_{pp}$   $V_{ID}$  sine wave,  $Z_O = 100\Omega$ , RGE package

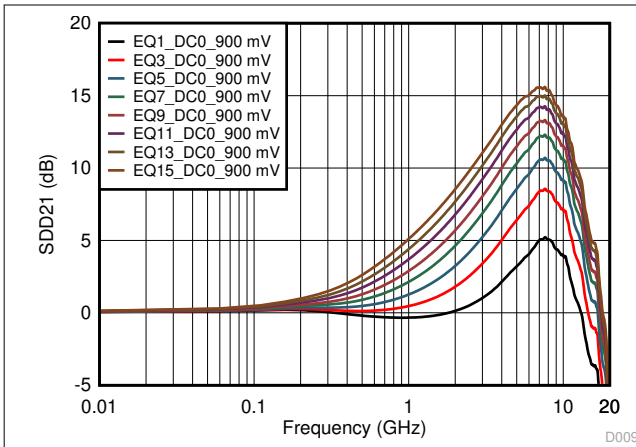

Figure 5-9. 900mV DC0 Gain Odd EQ Settings Curves

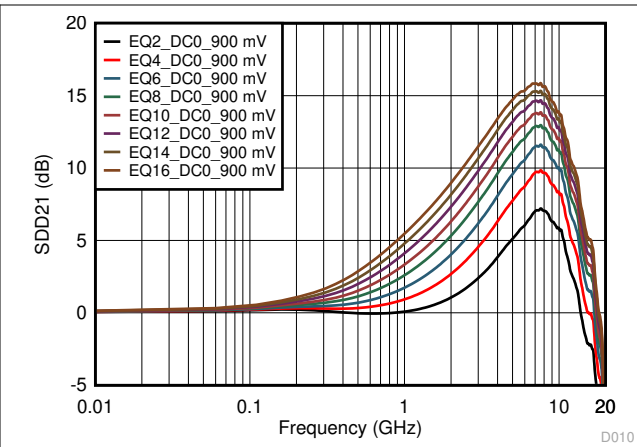

Figure 5-10. 900mV DC0 Gain Even EQ Settings Curves

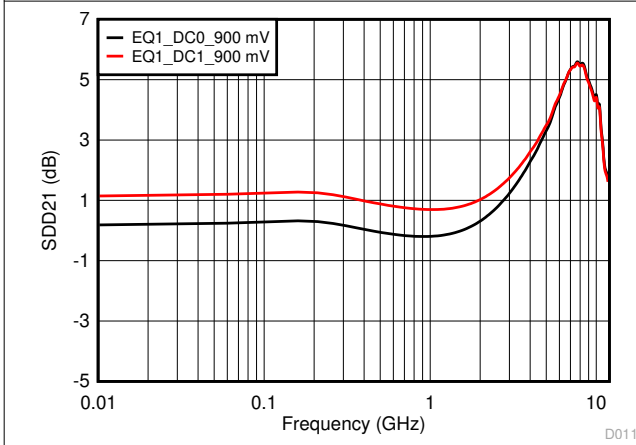

Figure 5-11. 900mV DC Gain Adjustment Curves

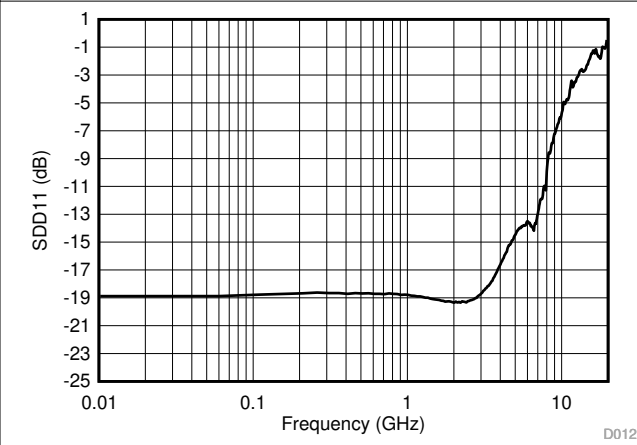

Figure 5-12. SDD11 Return Loss

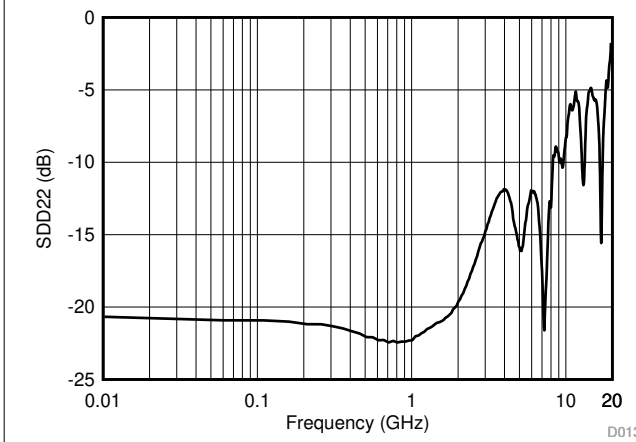

Figure 5-13. SDD22 Return Loss

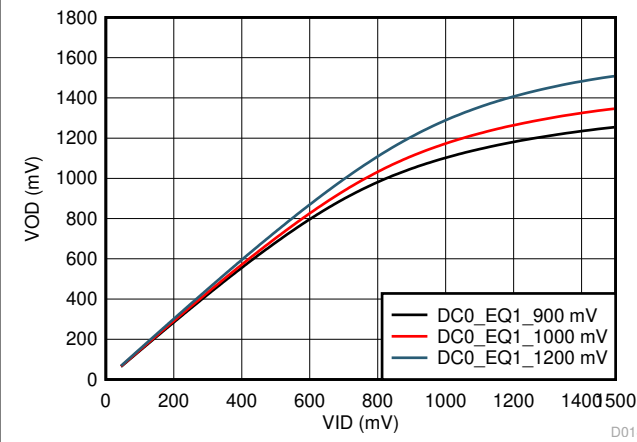

Figure 5-14. 5GHz Sine Wave VID vs VOD Linearity Range Setting

### 5.8 Typical Characteristics (continued)

$V_{CC} = 3.3V$  ,  $25^{\circ}C$  ,  $200mV_{pp}$   $V_{ID}$  sine wave,  $Z_O = 100\Omega$ , RGE package

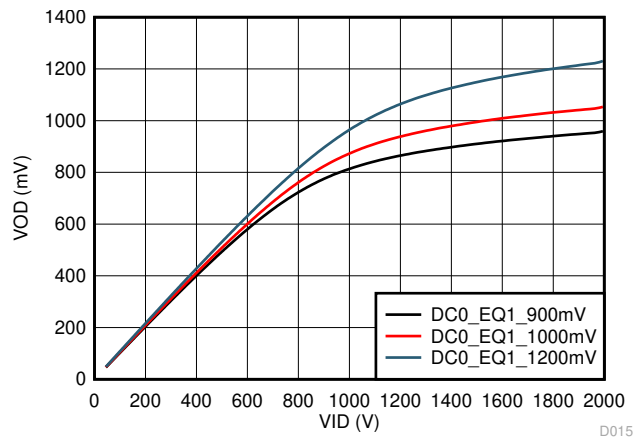

Figure 5-15. 100MHz Sine Wave VID vs VOD Linearity Range Setting D015

## 6 Detailed Description

### 6.1 Overview

The TUSB1002A is the industry's first, dual lane USB 3.2 x1 SuperSpeedPlus redriver. As signals traverse through a channel (like FR4 trace) the amplitude of the signal is attenuated. The attenuation varies depending on the frequency content of the signal. Depending the length of the channel this attenuation can be large enough resulting in signal integrity issues at a USB 3.2 receiver. By placing a TUSB1002A between USB3.2 host and device the attenuation effect of the channel can be eliminated or minimized. The result is a USB3.2 compatible eye at the devices receiver. With up to 16 receiver equalization settings, the TUSB1002A can support many different channel loss combinations. The TUSB1002A offers low power consumption on a single 3.3V supply and a ultra-low power architecture. The device supports the USB3.2 low power modes which further reduces idle power consumption. The TUSB1002A settings are configurable through pins. In addition to equalization adjustment, the TUSB1002A provides knobs for adjusting DC gain and voltage output linearity range.

### 6.2 Functional Block Diagram

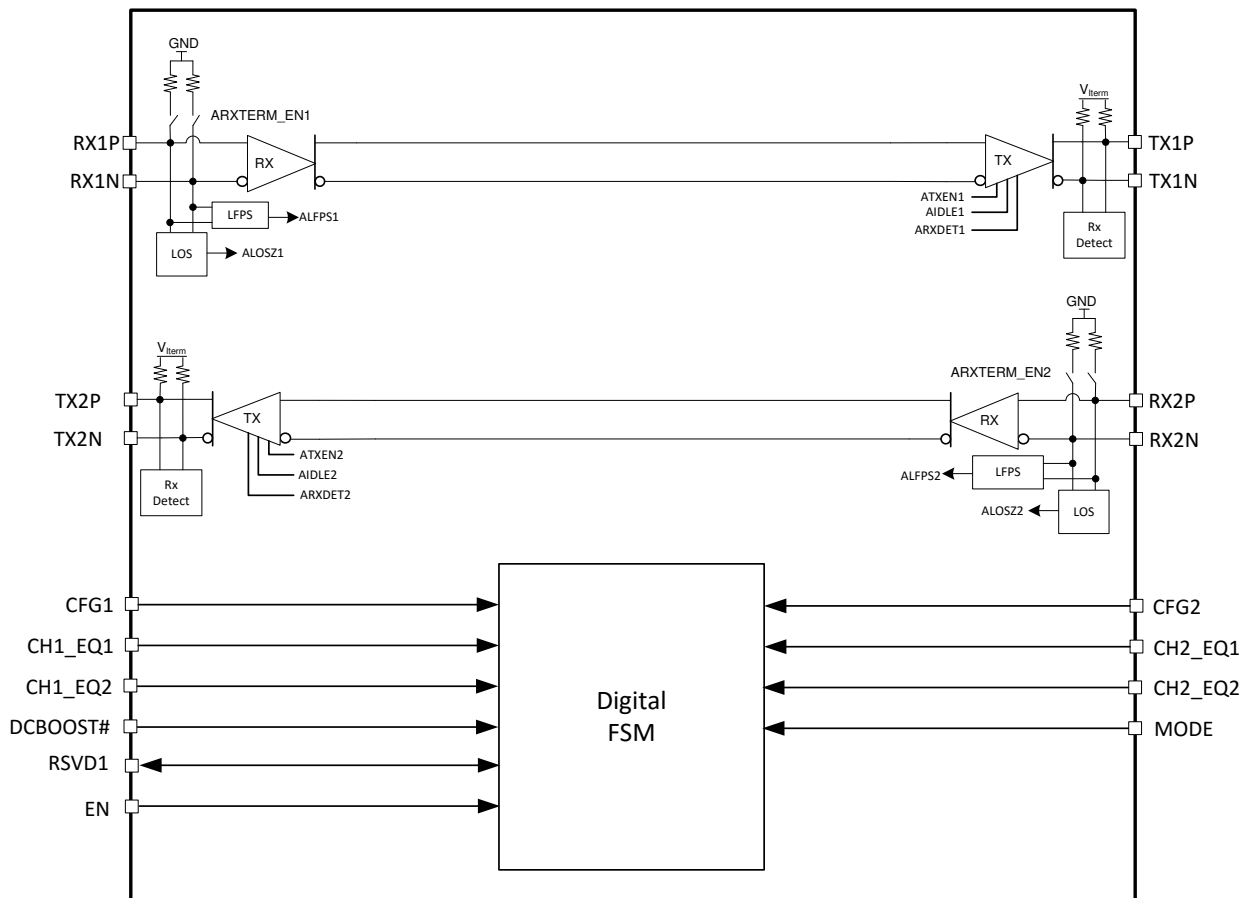

## 6.3 Feature Description

### 6.3.1 4-Level Control Inputs

The TUSB1002A has (MODE, CFG1, CFG2, CH1\_EQ1, CH1\_EQ2, CH2\_EQ1, and CH2\_EQ2) 4-level inputs pins that are used to control the equalization gain and the output voltage swing dynamic range. These 4-level inputs use a resistor divider to help set the four valid levels and provide a wider range of control settings. These resistors together with the external resistor connection combine to achieve the desired voltage level.

**Table 6-1. 4-Level Control Pin Settings**

LEVEL	SETTINGS
0	Option 1: Tie 1kΩ 5% to GND. Option 2: Tie directly to GND.
R	Tie 20kΩ 5% to GND.
F	Float (leave pin open)
1	Option 1: Tie 1kΩ 5% to V <sub>CC</sub> . Option 2: Tie directly to V <sub>CC</sub> .

#### Note

To conserve power, the TUSB1002A disables 4-level input's internal pullup/pulldown resistors after the state of 4-level pins have been sampled on rising edge of EN. A change of state for any four level input pin is not applied to TUSB1002A until after EN pin transitions from low to high.

### 6.3.2 Linear Equalization

With a linear equalizer, the TUSB1002A can electrically shorten a particular channel allowing for longer run lengths.

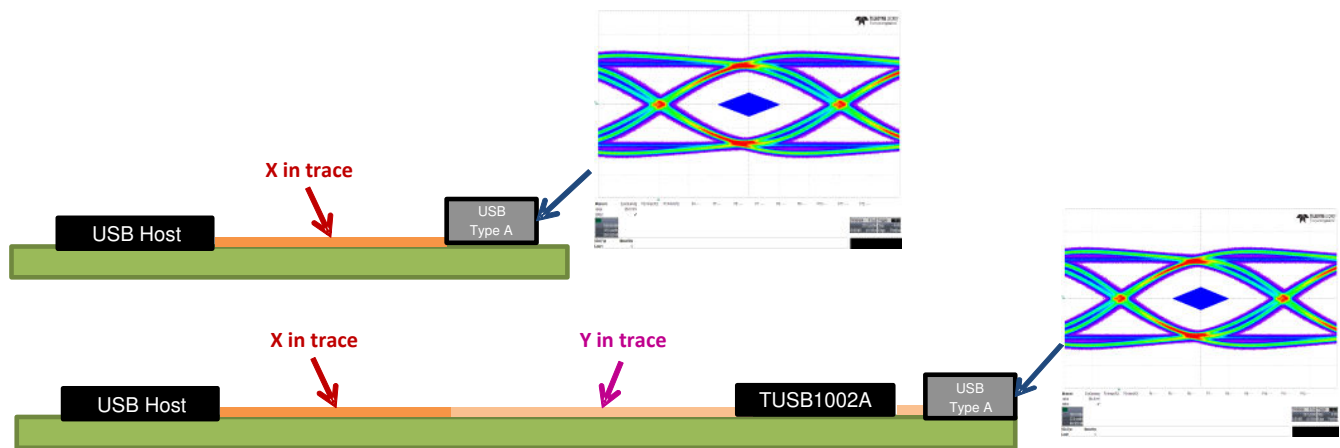

**Figure 6-1. Linear Equalizer**

With a TUSB1002A, a longer trace can be made to have similar insertion loss as a shorter trace. For example, a long trace of X + Y inches can be made to have similar loss characteristics of a shorter trace of X inches.

The receiver equalization level for each channel is determined by the state of the CH<sub>x</sub>\_EQ1 and CH<sub>x</sub>\_EQ2 pins, where x = 1 or 2.

**Table 6-2. EQ Configuration Options for 1200mV Linearity 0dB DC Gain Setting**

EQ SETTING #	CHx_EQ2 PIN LEVEL	CHx_EQ1 PIN LEVEL	EQ GAIN at 2.5GHz / 5GHz (dB)
1	0	0	1.0 / 3.6
2	0	R	2.1 / 5.5
3	0	F	3.0 / 6.8
4	0	1	4.0 / 8.1
5	R	0	4.6 / 9.0
6	R	R	5.5 / 10.0
7	R	F	6.2 / 10.8
8	R	1	6.9 / 11.6
9	F	0	7.3 / 11.9
10	F	R	7.9 / 12.6
11	F	F	8.4 / 13.1
12	F	1	9.0 / 13.7
13	1	0	9.4 / 14.1
14	1	R	9.9 / 14.6
15	1	F	10.3 / 14.9
16	1	1	10.7 / 15.3

### 6.3.3 Adjustable VOD Linear Range and DC Gain

The CFG1 and CFG2 pins can be used to adjust the TUSB1002A output voltage swing linear range and receiver equalization DC gain. [Table 6-3](#) details the available options.

For best performance, make sure to operate the TUSB1002A within the defined VOD linearity range. Keep the gain of the incoming VID to less than or equal to the TUSB1002A VOD linear range setting. The can be determined by [Equation 1](#):

$$\text{VID at 5GHz} = \text{VOD} \times (10^{-(Gv/20)}) \quad (1)$$

where

- $Gv$  = TUSB1002A Gain and VOD = TUSB1002A VOD linearity setting.

For example, for a VOD linearity range setting of 1200mV, the maximum incoming VID signal at 5GHz with a CHx\_EQ[1:0] setting of 2 (5.5dB) is  $1200 \times (10^{-(5.5/20)}) = 637\text{mVpp}$ . The TUSB1002A can operate outside VOD linear range, but the jitter will be higher.

**Table 6-3. VOD Linear Range and DC Gain**

SETTING #	CFG1 PIN LEVEL	CFG2 PIN LEVEL	CH1 DC GAIN (dB)	CH2 DC GAIN (dB)	CH1 V <sub>OD</sub> LINEAR RANGE (mVpp)	CH2 V <sub>OD</sub> LINEAR RANGE (mVpp)
1	0	0	+1	0	900	900
2	0	R	0	+1	900	900
3	0	F	0	0	900	900
4	0	1	+1	+1	900	900
5	R	0	0	0	1000	1000
6	R	R	+1	0	1000	1000
7	R	F	0	-1	1000	1000
8	R	1	+2	+2	1000	1000
9	F	0	-1	-1	1200	1200
10	F	R	+2	+2	1200	1200
11	F	F	0	0	1200	1200
12	F	1	+1	+1	1200	1200
13	1	0	+2	0	1200	1200
14	1	R	0	+2	1200	1200
15	1	F	0	+1	1200	1200

**Table 6-3. VOD Linear Range and DC Gain (continued)**

SETTING #	CFG1 PIN LEVEL	CFG2 PIN LEVEL	CH1 DC GAIN (dB)	CH2 DC GAIN (dB)	CH1 V <sub>OD</sub> LINEAR RANGE (mVpp)	CH2 V <sub>OD</sub> LINEAR RANGE (mVpp)
16	1	1	+1	0	1200	1200

### 6.3.4 USB3.2 Dual Channel Operation (MODE = "F")

The TUSB1002A in dual-channel operation waits for far-end terminations on both channels 1 and 2 before transitioning to fully active state (U0 mode). This mode of operation, defined as MODE pin = 'F', is the most common configurable for USB3.2 Source (DFP) and Sink (UFP) applications.

In a USB3.2 x2 application, two TUSB1002A redrivers are used: One on the configuration lane and the other on the non-configuration lane. The TUSB1002A on the non-configuration lane must be placed in basic redriver mode (MODE pin = "0"). Place the TUSB1002A on the configuration lane in USB3.2 dual channel operation (MODE pin = "F"). The expectation is the USB power delivery (PD) controller will hold both TUSB1002A in shutdown mode until a connection can be established. After a connection is established, the USB PD controller places each TUSB1002A into the appropriate mode.

### 6.3.5 USB3.2 Single Channel Operation (MODE = "1")

In some applications, like Type-C USB3.2 active cables, only one of the two channels may be active. For this application, setting MODE pin = '1', enables single-channel operation. In this mode of operation, the TUSB1002A attempts far-end termination on both channels 1 and 2. The channel which has a far-end termination detected is enabled while the remaining channel is disabled. If far-end termination is detected on both channels, then TUSB1002A behaves in dual channel operation (both channels enabled).

### 6.3.6 PCIe/SATA/SATA Express Redriver Operation (MODE = "R"; CFG1 = "0"; CFG2 = "0")

The TUSB1002A can be used as a PCI Express (PCIe) Gen3, SATA Gen3, or SATA Express redriver. When the MODE pin = "R", CFG1 pin = "0", and CFG2 pin = "0", the TUSB1002A enables both channels (upstream and downstream) receiver and transmitter paths after the device detects far-end termination on both TX1 and TX2. Both upstream and downstream paths remain enabled until EN pin is deasserted low. All USB3.2 power management functionality is disabled in this mode. In this mode, the TUSB1002A is transparent to PCIe link power management (L0s, L1) and SATA interface power states. After far-end termination is detected on both TX1 and TX2, the TUSB1002A power is at P<sub>(U0\_SSP\_1200mV)</sub> regardless of the PCIe or SATA power state. To save power during system S3/S4/S5 states it is suggested to deassert the EN pin to conserve power.

---

**Note**

In this mode the linearity range is fixed at 1200mVpp and DC gain to 0dB.

---

### 6.3.7 Basic Redriver Operation (MODE = "0")

The TUSB1002A can be used as a basic redriver for non-USB3.2 x1 applications. When the TUSB1002A MODE pin = "0", the TUSB1002A enables both channels receiver and transmitter paths. The channel receiver and transmitter termination are both enabled. All USB3.2 power management functionality is disabled.

## 6.4 Device Functional Modes

### 6.4.1 Shutdown Mode

The Shutdown mode is entered when EN pin is low and VCC is active and stable. This mode is the lowest power state of the TUSB1002A. While in this mode, the TUSB1002A receiver terminations is disabled.

### 6.4.2 Disconnect Mode

Next to Shutdown Mode, the Disconnect mode is the lowest power state of the TUSB1002A. The TUSB1002A enters this mode when exiting Shutdown mode. In this state, the TUSB1002A periodically checks for far-end receiver termination on both SSTX1 and SSTX2. After detection of the far-end receiver's termination on both ports, the TUSB1002A transitions to a fully active mode called U0 mode.

## 6.5 U0 Mode

The U0 mode is the highest power state of the TUSB1002A. Anytime high-speed traffic (SuperSpeed or SuperSpeedPlus) is being received, the TUSB1002A remains in this mode. The TUSB1002A only exits this mode if electrical idle is detected on both SSRX1 and SSRX2. While in this mode, the TUSB1002A hs speed receivers and transmitters are powered and active.

## 6.6 U1 Mode

The U1 mode is the intermediate mode between U0 mode and U2/U3 mode. In U1 mode, the TUSB1002A receiver termination remains enabled and the TXP/N DC common mode is maintained.

## 6.7 U2/U3 Mode

Next to the disconnect mode, the U2/U3 mode is next lowest power state. While in this mode, the TUSB1002A periodically performs far-end receiver detection. Anytime the far-end receiver termination is not detected on either CH1 or CH2, the TUSB1002A leaves the U2/U3 mode and transition to the Disconnect mode. The device also monitors the SSRX1 and SSRX2 for a valid LFPS. After a valid LFPS is detected, the TUSB1002A immediately transitions to the U0 mode.

## 7 Application and Implementation

### Note

Information in the following applications sections is not part of the TI component specification, and TI does not warrant its accuracy or completeness. TI's customers are responsible for determining suitability of components for their purposes, as well as validating and testing their design implementation to confirm system functionality.

### 7.1 Application Information

The TUSB1002A is a linear redriver designed specifically to compensation for ISI jitter caused by attenuation through a passive medium like traces and cables. Because the TUSB1002A has two independent channels, it can be optimized to correct ISI in both the upstream and downstream direction through 16 different equalization choices. Placing the TUSB1002A between a USB3.2 Host/device controller and a USB3.2 receptacle can correct signal integrity issues resulting in a more robust system.

### 7.2 Typical USB3.2 Application

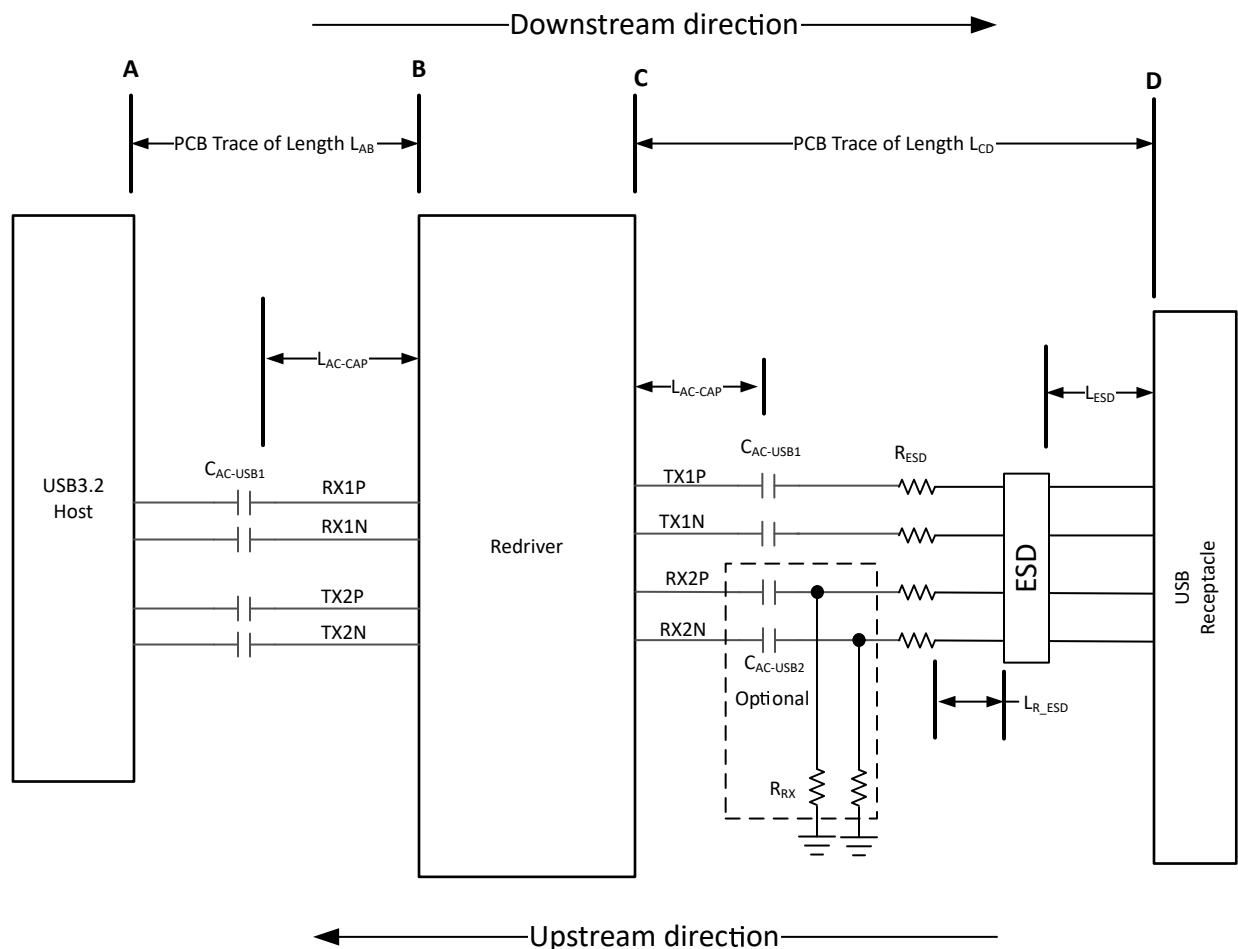

Figure 7-1. TUSB1002A in USB3.2 x1 Host Application

### 7.2.1 Design Requirements

For this design example, use the parameters shown in [Table 7-1](#).

**Table 7-1. Design Parameters**

PARAMETER	VALUE
Pre-channel A to B PCB trace length <sup>(1)</sup> , $L_{AB}$ .	1 inches $\leq L_{AB} \leq$ 12 inches - $L_{CD}$
Post-channel C to D PCB trace length <sup>(1)</sup> , $L_{CD}$ .	$\leq$ 4 inches
Minimum distance of the AC capacitors from TUSB1002A, $L_{AC-CAP}$	0.25 inches
Maximum distance of ESD component from the USB receptacle, $L_{ESD}$	0.6 inches
Maximum distance of series resistor ( $R_{ESD}$ ) from ESD component, $L_{R\_ESD}$ .	0.25 inches
$C_{AC-USB1}$ AC-coupling capacitor (75nF to 265nF)	220nF
$C_{AC-USB2}$ AC-coupling capacitor (297nF to 363nF)	Options: <ul style="list-style-type: none"> <li>RX1 and RX2 are DC-coupled to USB receptacle</li> <li>330nF AC-couple with <math>R_{RX}</math> resistor</li> </ul>
Optional $R_{RX}$ resistor (220k $\Omega$ $\pm$ 5%)	No used
Optional $R_{ESD}$ (0 $\Omega$ to 2.2 $\Omega$ )	1 $\Omega$
$V_{CC}$ supply (3V to 3.6-V)	3.3V
Mode of Operation (Dual or Half Channel)	MODE = F (Floating) for USB3.2 Dual Channel
Linear Range (900mV, 1000mV, or 1200 mV)	1200mV (CFG[2:1] pins floating)
DC Gain (-2, -1, 0, +1, +2)	0dB (CFG[2:1] pins floating)

(1) Maximum trace length assumes an insertion loss of 0.2dB/inch/GHz. If insertion loss is more than 0.2 dB/inch/GHz, then maximum trace length must be reduced accordingly.

### 7.2.2 Detailed Design Procedure

The TUSB1002A differential receivers and transmitters have internal BIAS and termination. For this reason, the TUSB1002A must be connected to the USB3.2 host and receptacle through external A/C coupling capacitors. In this example 220nF capacitors are placed on TX2P and TX2N, RX1P and RX1N, and TX1P and TX1N. 330nF A/C coupling capacitors along with 220k $\Omega$  resistors to ground are placed on the RX2P and RX2N. Inclusion of the 330nF capacitors and 220k resistors is optional. The ordered list below details the three implementation options for the RX2p/n path.

There are three implementation options for USB connector to the TUSB1002A RX pins:

- DC couple the TUSB1002A RX pins to USB connector. No 330nF capacitors and no 220k $\Omega$  pulldown resistors.
- 330nF capacitors with 220k $\Omega$  resistors as shown in [Figure 7-2](#). The purpose of 220k $\Omega$  resistors is to discharge the capacitor within 250ms after a USB device is removed from the USB connector.
- The stub from the 220k $\Omega$  resistor pad may create impedance discontinuities causing negative impact to performance. Assuming leakage current from external components is enough to discharge capacitor, 330nF capacitor without the 220k $\Omega$  resistor is a valid option.

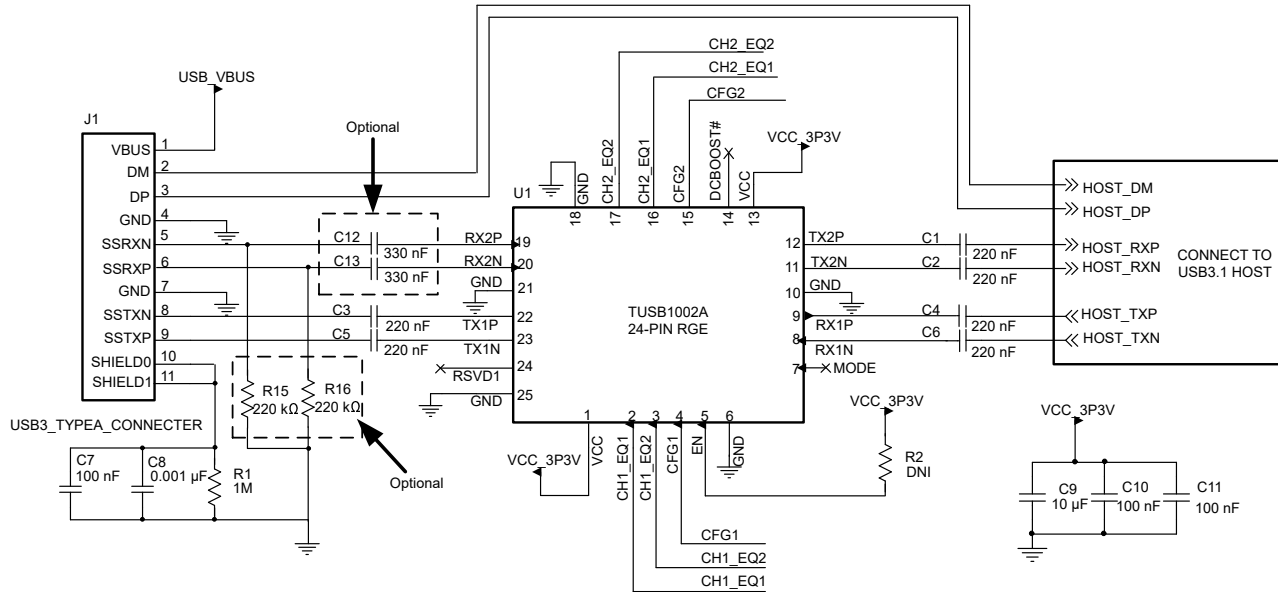

Copyright © 2018, Texas Instruments Incorporated

**Figure 7-2. Host Implementation Schematic**

The USB3.2 Dual channel operation is used in this example. Leave the mode pin floating (unconnected) when using this mode.

The TUSB1002A compensates for channel loss in both the upstream (D to C) and downstream direction (A to B). This is done by configuring the CH1\_EQ[2:1] and CH2\_EQ[2:1] pins to the equalization setting that matches as close possible to the channel insertion loss. In this particular example, CH1\_EQ[2:1] is for path A to B which is the channel between USB3.2 host and the TUSB1002A, and CH2\_EQ[2:1] is for path C to D which is the channel between TUSB1002A and the USB3.2 receptacle.

The TUSB1002A supports five levels of DC gain that are selected by the CFG[2:1] pins. Typically, the DC gain is set to 0dB but may need to be adjusted to correct any one of the following conditions:

1. Input  $V_{ID}$  too high resulting in  $V_{OD}$  being greater than USB 3.2 defined swing. For this case, use a negative DC gain.
2. Input  $V_{ID}$  too low resulting in  $V_{OD}$  being less than USB 3.2 defined swing. For this case, use a positive DC gain.
3. Low frequency discontinuities in the channel resulting in DC component of the signal clipping the vertical eye mask. For this case, use a positive DC gain.

Assume in this example that the incoming  $V_{ID}$  is at the nominal defined USB3.2 range and the channel is linear across frequency. The CFG1 and CFG2 pins can both be left floating if these assumptions are true.

In this particular example, the channel A-B has a trace length of 8 inches with a 4mil trace width. This particular channel has about 0.83dB per inch of insertion loss at 5GHz. This equates to approximately 6.7dB of loss for the entire 8 inches of trace. An additional 1.5dB of loss is added due to package of the USB3.2 Host, TUSB1002A, and the A/C coupling capacitor. This brings the entire channel loss at 5GHz to 6.7dB + 1.5dB = 8.2dB. A typical USB 3.1 host/device has around 3dB of transmitter de-emphasis. Transmitter de-emphasis pre-compensates for the loss of the output channel. With 3dB of de-emphasis, the total equalization required by the TUSB1002A is in the 5.2dB (8.2dB - 3dB) range. The channel A-B for this example is connected to the RX1P/N input of the device, therefore the CH1\_EQ[2:1] pins are used to adjust the TUSB1002A RX1P/N equalization settings. Set the CH1\_EQ[2:1] pins such that the TUSB1002A equalization is between 5dB and 8dB.

The channel C-D has a trace length of 2 inches with a 4mil trace width. Assuming 0.83dB per inch of insertion loss, the 2 inch trace equates to about 1.66dB of loss at 5GHz. An additional 2dB of loss needs to be added due to package, A/C coupling capacitor, and the USB 3.1 receptacle. The total loss is around 3.66dB. Because channel C-D includes a USB 3.1 receptacle, the actual total loss can be much greater than 3.66dB due to the fact that devices plugged into the receptacle will also have loss. The device plugged into receptacle will have either a short or long channel. USB3.2 standard defines total loss limit of 23dB that is distributed as 8.5dB for Host, 8.5dB for device, and 6.0dB for cable. With variable channel of devices plugged into the USB3.2 receptacle, the configurable TUSB1002A RX2P/N equalization settings is not as straight forward as Channel A-B.

Engineer can not set TUSB1002A CH2\_EQ[2:1] pins to the largest equalization setting to accommodate the largest allowed USB3.2 device/cable loss of 14.5dB, because doing so will cause the TUSB1002A to operate outside its linear range when a device with short channel is plugged into the receptacle. For this reason, TI recommends configure the TUSB1002A CH2\_EQ[2:1] pins to equalize a shorter device channel, which will require the USB3.2 host to compensate for remaining channel loss for the worse case USB3.2 channel of 14.5dB. The definition of a short device channel is not specified in USB 3.2 specification. Therefore, an engineer must make their own loss estimate of what constitutes a short device channel. For particular example, assume the short channel is around 2 to 3dB. The channel loss of the device must be added to the estimated Channel C-D loss minus the typical 3dB of de-emphasis. This means CH2\_EQ[2:1] pins can be configured to handle a loss of 3dB to 5dB.

### 7.2.3 ESD Protection

It may be necessary to incorporate an ESD component to protect the TUSB1002A from electrostatic discharge (ESD). TI recommends following the ESD protection recommendations listed in [Table 7-2](#). A clamp voltage greater than value specified in [Table 7-2](#) may require a  $R_{ESD}$  on each differential pin. Place the ESD component near the USB connector.

**Table 7-2. ESD Diodes Recommended Characteristics**

Parameter	Recommendation
Breakdown voltage	$\geq 3.5V$
I/O line capacitance	Data rates $\leq 5Gbps$ : $\leq 0.50pF$
	Data rates $> 5Gbps$ : $\leq 0.35pF$
Delta capacitance between any P and N I/O pins	$\leq 0.07pF$
Clamping voltage at 8A $I_{PP}$ IO to GND <sup>(1)</sup>	$\leq 4.5V$
Typical dynamic resistance	$\leq 30m\Omega$

(1) According to IEC 61000-4-5 (8/20 $\mu s$  current waveform)

**Table 7-3. Recommended ESD Protection Component**

Manufacturer	Part Number	$R_{ESD}$ to pass IEC 61000-4-2 Contact $\pm 8kV$
Nexperia	PUSB3FR4	2 $\Omega$
Nexperia	PESD2V8Y1BSF	2 $\Omega$
Texas Instruments	TPD1E04U04DPLR	2 $\Omega$
Texas Instruments	TPD4E02B04DQAR	2 $\Omega$

### 7.2.4 Application Curves

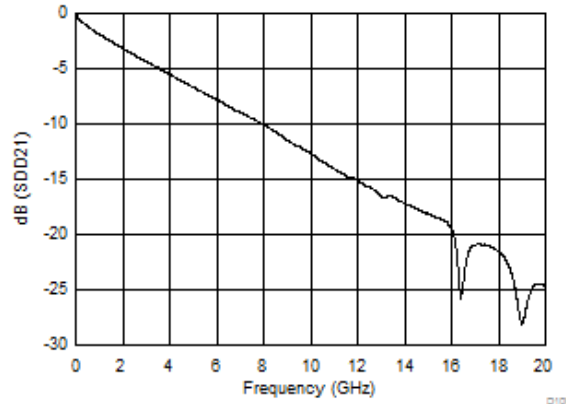

Freq = 5GHz

dB(SDD21) = -6.666

Figure 7-3. Insertion Loss for 8-inch 4mil FR4 Trace

### 7.3 Typical SATA, PCIe and SATA Express Application

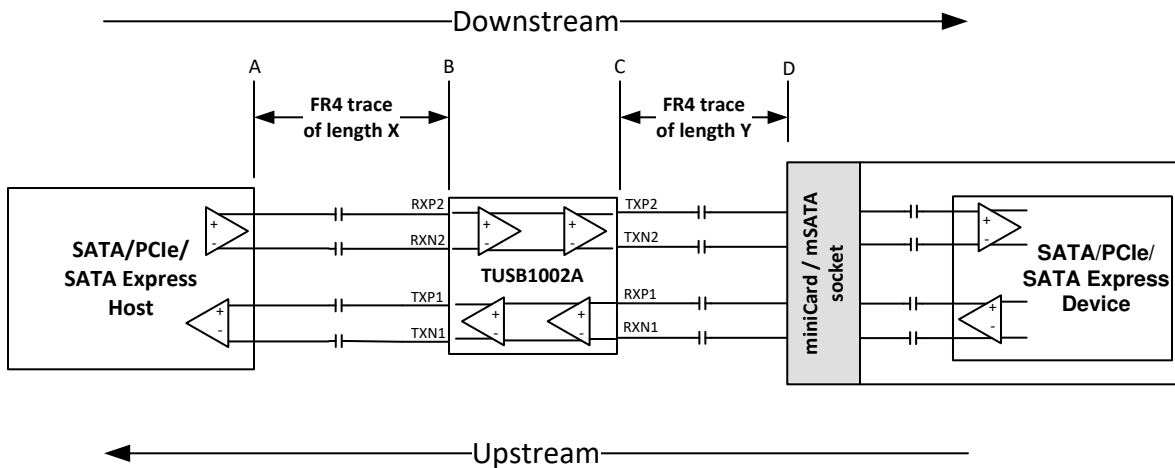

Figure 7-4. SATA/PCIe/SATA Express Typical Application

#### 7.3.1 Design Requirements

Table 7-4. Design Parameters

PARAMETER	VALUE
VCC supply (3V to 3.6V)	3.3V
PCIe Support Required (Yes/No)	Yes
SATA Express Support Required (Yes/No)	Yes
SATA Support Required (Yes/No)	Yes, then ferrite beads (FB1 and FB2) and 49.9Ω required. No, then ferrite bead (FB1 and FB2) and 49.9Ω not required.
TX1, TX2, RX2 A/C coupling Capacitor (176nF to 265nF)	220nF ±10%
RX1 A/C coupling Capacitor (297nF to 363nF)	Optional. But if implemented suggest 330nF ±10%
A to B FR4 Length (inches)	8
A to B FR4 Trace Width (mils)	4
C to D FR4 length (inches)	2

**Table 7-4. Design Parameters (continued)**

PARAMETER	VALUE
C to D FR4 Trace Width (mils)	4
DC Gain (-2, -1, 0, +1, +2)	Not configurable when MODE = "R", CFG1 = "0", and CFG2 = "0". Will always default to 0dB
Linear Range (900mV, 1000mV, or 1200mV)	Not configurable when MODE = "R", CFG1 = "0", and CFG2 = "0". Will always default to 1200mV

### 7.3.2 Detailed Design Procedure

The MODE pin = "R", CFG1 = "0", and CFG2 = "0" places the TUSB1002A into PCIe mode. In this mode, the TUSB1002A DC gain is fixed at 0dB and its linearity range is fixed at 1200mV. The TUSB1002A performs far-end receiver termination detection and enables both upstream and downstream paths when far-end termination is detected on both TX1 and TX2.

The AC coupling capacitor range defined for a SATA device is a lot smaller than the AC-coupling capacitor range defined for SATA Express and PCI Express (PCIe) as indicated by Figure 7-5. The AC-coupling capacitor range defined for SATA Express and PCI Express is within the same range as the AC-coupling capacitor range defined by USB 3.1. The TUSB1002A is able to detect PCIe and SATA Express device's receiver termination. The SATA 12nF (maximum) AC-coupling capacitor prevents TUSB1002A from detecting the SATA device receiver termination. To correct this problem, a ferrite bead along with 49.9Ω resistor must be placed between C<sub>TX2</sub> and miniCard/mSATA socket. These components can be isolated from the high-speed channel when PCIe or SATA Express is active by using an NFET as shown in Figure 7-6. The NFET is enabled whenever a SATA device is present. The ferrite bead chosen must present at least 600Ω impedance at 100MHz so as to not impact high-speed signaling. TI recommends to use Murata BLM03AG601SN1 or BLM03HD601SN1D or a ferrite bead with similar characteristics from a different vendor. For applications which only require support for PCIe and SATA Express and do not need to support SATA, the ferrite beads and 49.9Ω resistors are not needed.

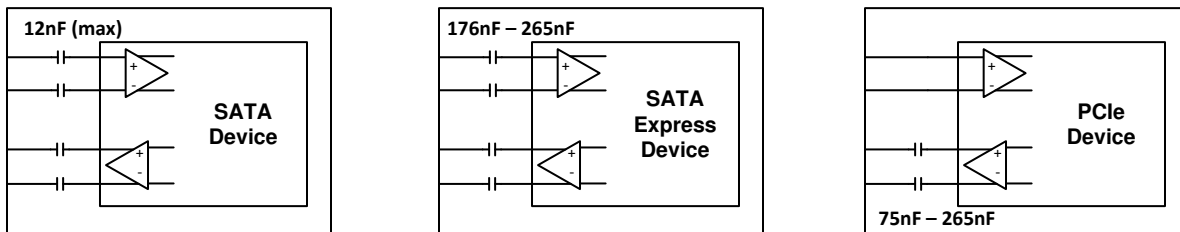

**Figure 7-5. AC-Coupling Capacitor Implementation for SATA, SATA Express, and PCIe Devices**

The TUSB1002A power is at  $P_{(U0\_SSP\_1200mV)}$  when both its upstream and downstream paths are enabled. In order to save system power in system S3/S4/S5 states, it is suggested to control the TUSB1002A EN pin. Anytime the system enters a low power state (S3, S4, or S5), it is suggested to deassert the EN pin. While EN pin is deasserted, the TUSB1002A consumes  $P_{(SHUTDOWN)}$ . Assertion of this pin is necessary anytime the system exits a lower power state.

The TUSB1002A compensates for channel loss in both the upstream (C to D) and downstream direction (A to B). This is done by configurable the CH1\_EQ[2:1] and CH2\_EQ[2:1] pins to the equalization setting that matches as close possible to the channel insertion loss. In this particular example, CH2\_EQ[2:1] is for path A to B which is the channel between PCIe/SATA/SATA Express host and the TUSB1002A, and CH1\_EQ[2:1] is for path C to D which is the channel between TUSB1002A and the miniCard/mSATA socket.

In this particular example, the channel A-B has a trace length of 8 inches with a 4mil trace width. This particular channel has about 0.83dB per inch of insertion loss at 5GHz. This equates to approximately 6.7dB of loss for the entire 8 inches of trace as depicted in Figure 7-3. An additional 1.5dB of loss is added due to package of the PCIe/SATA/SATA Express Host, TUSB1002A, and the A/C coupling capacitor. This brings the entire channel loss at 5GHz to 6.7dB + 1.5dB = 8.2dB. The channel A-B for this example is connected to the TUSB1002A RX2P/N input, therefore the CH2\_EQ[2:1] pins are used to adjust the TUSB1002A RX2P/N equalization settings.

Set the CH2\_EQ[2:1] pins such that the TUSB1002A equalization is between 5dB and 8dB. A value closer to 5dB maybe best if Host has transmitter de-emphasis.

A similar method can be used for the upstream path (C to D). In this particular example, C to D has a trace length of 2 inches with a 4mil trace width. This equates to approximately 1.5dB at 5GHz. The SATA/SATA Express/PCIe device will also have channel loss. This loss can be added to the C to D channel loss. For this example, assume a value of 5dB is acceptable to compensate for C to D channel loss as well as loss associated with the SATA/SATA Express/PCIe device. Set the CH1\_EQ[2:1] pins such that the TUSB1002A equalization is 5dB.

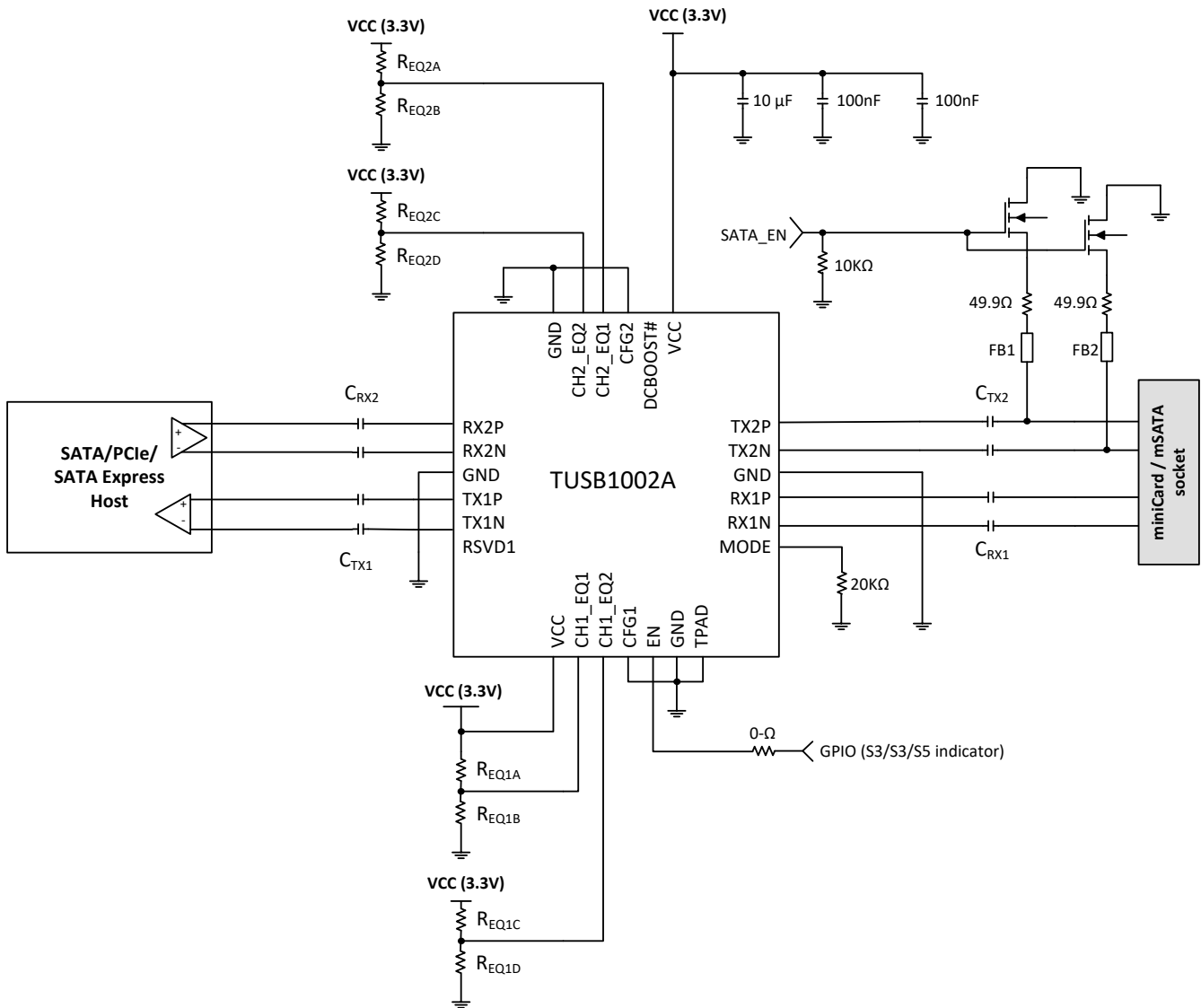

Figure 7-6. Example SATA/PCIe/SATA Express Schematic

### 7.3.3 Application Curves

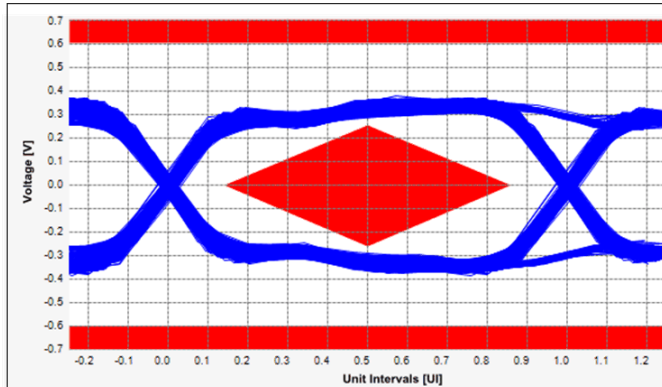

Figure 7-7. PCIe Gen1 TX Eye Diagram

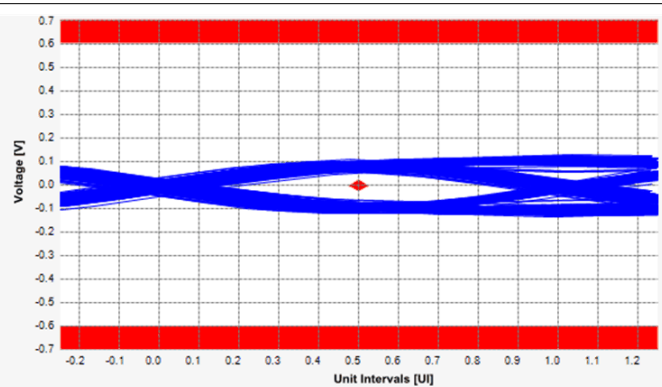

Figure 7-8. PCIe Gen3 TX Eye Diagram

## 7.4 Power Supply Recommendations

The TUSB1002A has two  $V_{CC}$  supply pins. TI recommends to place a 100nF de-coupling capacitor near each of the  $V_{CC}$  pins. TI also recommends to have at least one bulk capacitor of at least 10 $\mu$ F on the  $V_{CC}$  plane near the TUSB1002A.

## 7.5 Layout

### 7.5.1 Layout Guidelines

- Route RXP/N and TXP/N pairs with controlled 90 $\Omega$  differential impedance ( $\pm 15\%$ ).
- Keep away from other high speed signals.
- In USB3 applications maintaining polarity through the TUSB1002A is not necessary. Therefore, TI recommends connecting polarity in such a way that produces the best routing.
- Keep intra-pair routing to within 2mils.
- Intra-pair length matching must be near the location of mismatch.
- Inter-pair length matching is not necessary.
- Separate each pair at least by 3 times the signal trace width.
- Keep the use of bends in differential traces to a minimum. When bends are used, keep the number of left and right bends equal as possible and the angle of the bend should be  $\geq 135$  degrees. This minimizes any length mismatch causes by the bends; and therefore, minimize the impact bends have on EMI.
- Route all differential pairs on the same of layer.
- The number of VIAS must be kept to a minimum. TI recommends keeping the VIAS count to 2 or less.
- Keep traces on layers adjacent to ground plane.
- Do NOT route differential pairs over any plane split.
- When using thru-hole USB connectors, it is recommend to route differential pairs on bottom layer in order to minimize the stub created by the thru-hole connector.
- Adding Test points causes impedance discontinuity; and therefore, negatively impact signal performance. If test points are used, place the test points in series and symmetrically. They must not be placed in a manner that causes a stub on the differential pair.

7.5.2 Layout Example

Example 4 layer PCB Stackup

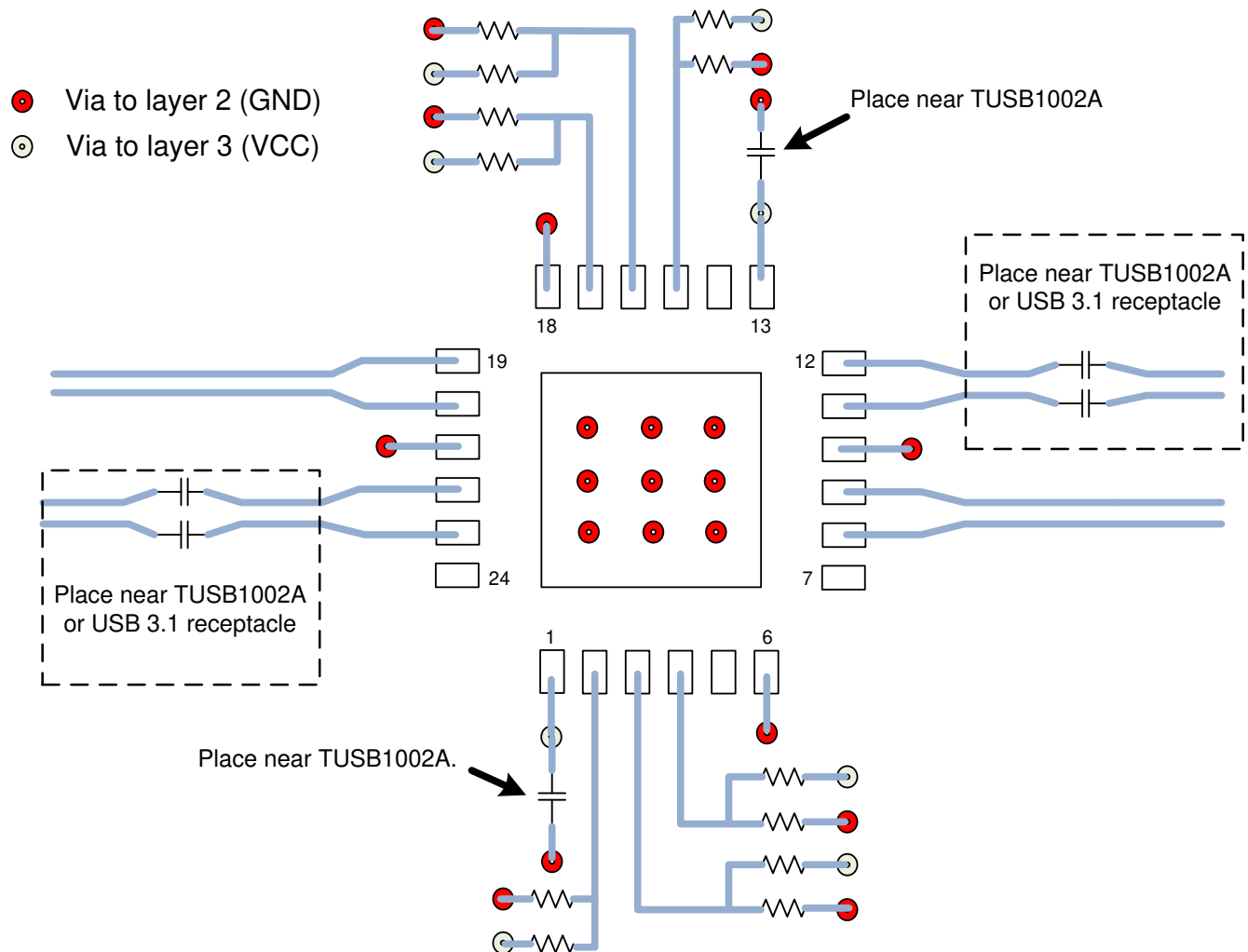
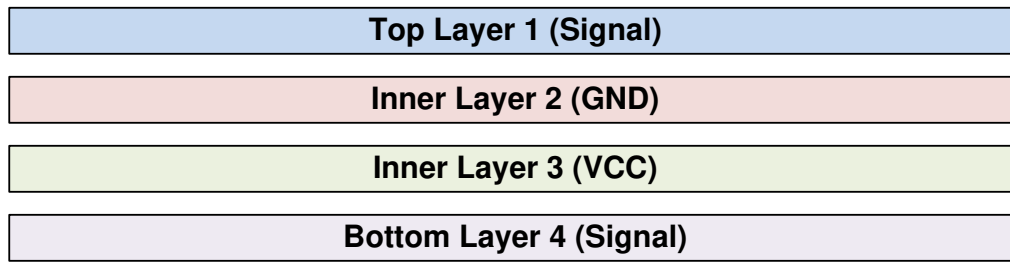

Figure 7-9. Example Layout

## 8 Device and Documentation Support

### 8.1 Receiving Notification of Documentation Updates

To receive notification of documentation updates, navigate to the device product folder on [ti.com](http://ti.com). Click on *Notifications* to register and receive a weekly digest of any product information that has changed. For change details, review the revision history included in any revised document.

### 8.2 Support Resources

[TI E2E™ support forums](#) are an engineer's go-to source for fast, verified answers and design help — straight from the experts. Search existing answers or ask your own question to get the quick design help you need.

Linked content is provided "AS IS" by the respective contributors. They do not constitute TI specifications and do not necessarily reflect TI's views; see TI's [Terms of Use](#).

### 8.3 Trademarks

TI E2E™ is a trademark of Texas Instruments.

All trademarks are the property of their respective owners.

### 8.4 Electrostatic Discharge Caution



This integrated circuit can be damaged by ESD. Texas Instruments recommends that all integrated circuits be handled with appropriate precautions. Failure to observe proper handling and installation procedures can cause damage.

ESD damage can range from subtle performance degradation to complete device failure. Precision integrated circuits may be more susceptible to damage because very small parametric changes could cause the device not to meet its published specifications.

### 8.5 Glossary

[TI Glossary](#) This glossary lists and explains terms, acronyms, and definitions.

## 9 Revision History

NOTE: Page numbers for previous revisions may differ from page numbers in the current version.

<b>Changes from Revision B (October 2023) to Revision C (July 2024)</b>	<b>Page</b>
• Added the <i>ESD Diodes Recommendations Characteristics</i> table.....	<a href="#">22</a>
• Changed recommended R <sub>ESD</sub> for Nexperia from none to 2Ω.....	<a href="#">22</a>

---

<b>Changes from Revision A (November 2018) to Revision B (October 2023)</b>	<b>Page</b>
• Updated the numbering format for tables, figures, and cross-references throughout the document.....	<a href="#">1</a>
• Updated the <i>Device Information</i> table to include ambient temperature .....	<a href="#">1</a>
• Updated the <i>TUSB1002A in ESB3.2 x1 Host Application</i> figure to include ESD and optional 220kΩ pulldown on RX pins.....	<a href="#">19</a>
• Updated the <i>Design Parameters</i> table to include pre-channel and post-channel min/max limits.....	<a href="#">20</a>
• Changed 100nF recommendation to 220nF for ac-coupling capacitors .....	<a href="#">20</a>
• Added the <i>ESD Protection</i> section.....	<a href="#">22</a>

---

<b>Changes from Revision * (March 2018) to Revision A (November 2018)</b>	<b>Page</b>
• Changed text from: "Inclusion of these 330nF capacitors and 220kΩ resistors is optional but highly recommended." to: "Inclusion of the 330nF capacitors and 220kΩ resistors is optional." in the <i>Detailed Design Procedure</i> .....	<a href="#">20</a>
• Added ordered list of implementation options for USB connector to TUSB1002A RX pins .....	<a href="#">20</a>

## 10 Mechanical, Packaging, and Orderable Information

The following pages include mechanical, packaging, and orderable information. This information is the most current data available for the designated devices. This data is subject to change without notice and revision of this document. For browser-based versions of this data sheet, refer to the left-hand navigation.

**PACKAGING INFORMATION**

Orderable part number	Status (1)	Material type (2)	Package   Pins	Package qty   Carrier	RoHS (3)	Lead finish/ Ball material (4)	MSL rating/ Peak reflow (5)	Op temp (°C)	Part marking (6)
<a href="#">TUSB1002AIRGER</a>	Active	Production	VQFN (RGE)   24	3000   LARGE T&R	Yes	NIPDAU	Level-1-260C-UNLIM	-40 to 85	TUSB 1002A
TUSB1002AIRGER.B	Active	Production	VQFN (RGE)   24	3000   LARGE T&R	Yes	NIPDAU	Level-1-260C-UNLIM	-40 to 85	TUSB 1002A
TUSB1002AIRGERG4	Active	Production	VQFN (RGE)   24	3000   LARGE T&R	Yes	NIPDAU	Level-1-260C-UNLIM	-40 to 85	TUSB 1002A
TUSB1002AIRGERG4.B	Active	Production	VQFN (RGE)   24	3000   LARGE T&R	Yes	NIPDAU	Level-1-260C-UNLIM	-40 to 85	TUSB 1002A
<a href="#">TUSB1002AIRGET</a>	Active	Production	VQFN (RGE)   24	250   SMALL T&R	Yes	SN	Level-1-260C-UNLIM	-40 to 85	TUSB 1002A
TUSB1002AIRGET.B	Active	Production	VQFN (RGE)   24	250   SMALL T&R	Yes	SN	Level-1-260C-UNLIM	-40 to 85	TUSB 1002A
<a href="#">TUSB1002ARGER</a>	Active	Production	VQFN (RGE)   24	3000   LARGE T&R	Yes	NIPDAU	Level-1-260C-UNLIM	0 to 70	TUSB 1002A
TUSB1002ARGER.B	Active	Production	VQFN (RGE)   24	3000   LARGE T&R	Yes	NIPDAU	Level-1-260C-UNLIM	0 to 70	TUSB 1002A
<a href="#">TUSB1002ARGET</a>	Active	Production	VQFN (RGE)   24	250   SMALL T&R	Yes	NIPDAU	Level-1-260C-UNLIM	0 to 70	TUSB 1002A
TUSB1002ARGET.B	Active	Production	VQFN (RGE)   24	250   SMALL T&R	Yes	NIPDAU	Level-1-260C-UNLIM	0 to 70	TUSB 1002A

(1) **Status:** For more details on status, see our [product life cycle](#).

(2) **Material type:** When designated, preproduction parts are prototypes/experimental devices, and are not yet approved or released for full production. Testing and final process, including without limitation quality assurance, reliability performance testing, and/or process qualification, may not yet be complete, and this item is subject to further changes or possible discontinuation. If available for ordering, purchases will be subject to an additional waiver at checkout, and are intended for early internal evaluation purposes only. These items are sold without warranties of any kind.

(3) **RoHS values:** Yes, No, RoHS Exempt. See the [TI RoHS Statement](#) for additional information and value definition.

(4) **Lead finish/Ball material:** Parts may have multiple material finish options. Finish options are separated by a vertical ruled line. Lead finish/Ball material values may wrap to two lines if the finish value exceeds the maximum column width.

(5) **MSL rating/Peak reflow:** The moisture sensitivity level ratings and peak solder (reflow) temperatures. In the event that a part has multiple moisture sensitivity ratings, only the lowest level per JEDEC standards is shown. Refer to the shipping label for the actual reflow temperature that will be used to mount the part to the printed circuit board.

(6) **Part marking:** There may be an additional marking, which relates to the logo, the lot trace code information, or the environmental category of the part.

Multiple part markings will be inside parentheses. Only one part marking contained in parentheses and separated by a "~" will appear on a part. If a line is indented then it is a continuation of the previous line and the two combined represent the entire part marking for that device.

**Important Information and Disclaimer:**The information provided on this page represents TI's knowledge and belief as of the date that it is provided. TI bases its knowledge and belief on information provided by third parties, and makes no representation or warranty as to the accuracy of such information. Efforts are underway to better integrate information from third parties. TI has taken and continues to take reasonable steps to provide representative and accurate information but may not have conducted destructive testing or chemical analysis on incoming materials and chemicals. TI and TI suppliers consider certain information to be proprietary, and thus CAS numbers and other limited information may not be available for release.

In no event shall TI's liability arising out of such information exceed the total purchase price of the TI part(s) at issue in this document sold by TI to Customer on an annual basis.

**TAPE AND REEL INFORMATION**

**QUADRANT ASSIGNMENTS FOR PIN 1 ORIENTATION IN TAPE**

\*All dimensions are nominal

Device	Package Type	Package Drawing	Pins	SPQ	Reel Diameter (mm)	Reel Width W1 (mm)	A0 (mm)	B0 (mm)	K0 (mm)	P1 (mm)	W (mm)	Pin1 Quadrant
TUSB1002AIRGER	VQFN	RGE	24	3000	330.0	12.4	4.25	4.25	1.15	8.0	12.0	Q2
TUSB1002AIRGERG4	VQFN	RGE	24	3000	330.0	12.4	4.25	4.25	1.15	8.0	12.0	Q2
TUSB1002AIRGET	VQFN	RGE	24	250	180.0	12.4	4.25	4.25	1.15	8.0	12.0	Q2
TUSB1002ARGER	VQFN	RGE	24	3000	330.0	12.4	4.25	4.25	1.15	8.0	12.0	Q2
TUSB1002ARGET	VQFN	RGE	24	250	180.0	12.4	4.25	4.25	1.15	8.0	12.0	Q2

**TAPE AND REEL BOX DIMENSIONS**

\*All dimensions are nominal

Device	Package Type	Package Drawing	Pins	SPQ	Length (mm)	Width (mm)	Height (mm)
TUSB1002AIRGER	VQFN	RGE	24	3000	367.0	367.0	35.0
TUSB1002AIRGERG4	VQFN	RGE	24	3000	367.0	367.0	35.0
TUSB1002ARGET	VQFN	RGE	24	250	210.0	185.0	35.0
TUSB1002ARGER	VQFN	RGE	24	3000	367.0	367.0	35.0
TUSB1002ARGET	VQFN	RGE	24	250	210.0	185.0	35.0

## GENERIC PACKAGE VIEW

RGE 24

VQFN - 1 mm max height

PLASTIC QUAD FLATPACK - NO LEAD

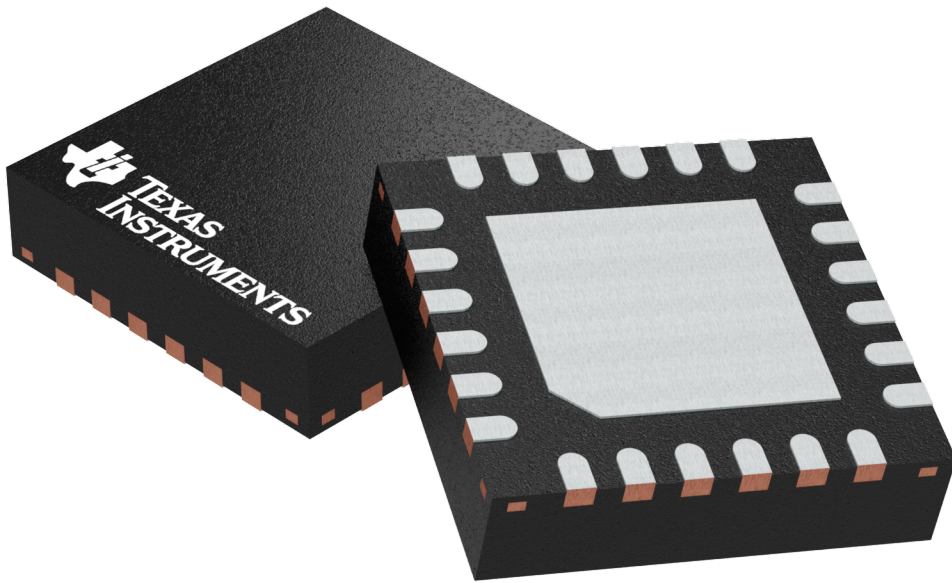

Images above are just a representation of the package family, actual package may vary.  
Refer to the product data sheet for package details.

4204104/H





LAND PATTERN EXAMPLE  
SCALE: 20X

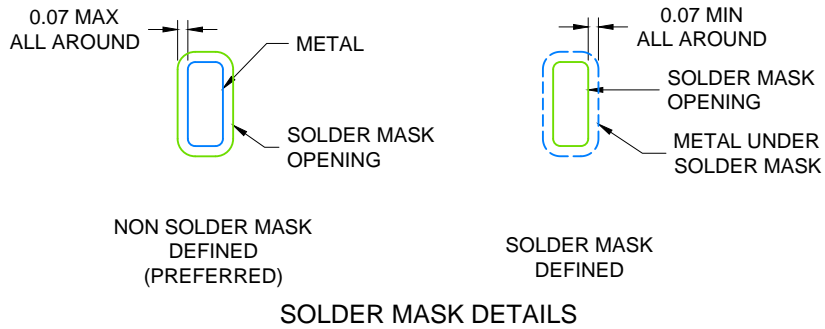

4219016 / A 08/2017

NOTES: (continued)

4. This package is designed to be soldered to a thermal pad on the board. For more information, see Texas Instruments literature number SLUA271 ([www.ti.com/lit/slua271](http://www.ti.com/lit/slua271)).
5. Solder mask tolerances between and around signal pads can vary based on board fabrication site.



## IMPORTANT NOTICE AND DISCLAIMER

TI PROVIDES TECHNICAL AND RELIABILITY DATA (INCLUDING DATASHEETS), DESIGN RESOURCES (INCLUDING REFERENCE DESIGNS), APPLICATION OR OTHER DESIGN ADVICE, WEB TOOLS, SAFETY INFORMATION, AND OTHER RESOURCES "AS IS" AND WITH ALL FAULTS, AND DISCLAIMS ALL WARRANTIES, EXPRESS AND IMPLIED, INCLUDING WITHOUT LIMITATION ANY IMPLIED WARRANTIES OF MERCHANTABILITY, FITNESS FOR A PARTICULAR PURPOSE OR NON-INFRINGEMENT OF THIRD PARTY INTELLECTUAL PROPERTY RIGHTS.

These resources are intended for skilled developers designing with TI products. You are solely responsible for (1) selecting the appropriate TI products for your application, (2) designing, validating and testing your application, and (3) ensuring your application meets applicable standards, and any other safety, security, regulatory or other requirements.

These resources are subject to change without notice. TI grants you permission to use these resources only for development of an application that uses the TI products described in the resource. Other reproduction and display of these resources is prohibited. No license is granted to any other TI intellectual property right or to any third party intellectual property right. TI disclaims responsibility for, and you fully indemnify TI and its representatives against any claims, damages, costs, losses, and liabilities arising out of your use of these resources.

TI's products are provided subject to [TI's Terms of Sale](#), [TI's General Quality Guidelines](#), or other applicable terms available either on [ti.com](http://ti.com) or provided in conjunction with such TI products. TI's provision of these resources does not expand or otherwise alter TI's applicable warranties or warranty disclaimers for TI products. Unless TI explicitly designates a product as custom or customer-specified, TI products are standard, catalog, general purpose devices.

TI objects to and rejects any additional or different terms you may propose.

Copyright © 2026, Texas Instruments Incorporated

Last updated 10/2025