

SNx4ACT86 Quadruple 2-Input Exclusive-OR Gates

1 Features

- 4.5V to 5.5V V_{CC} operation
- Inputs accept voltages to 5.5V
- Max t_{pd} of 10ns at 5V
- Inputs are TTL-voltage compatible

2 Description

The 'ACT86 devices are quadruple 2-input exclusive-OR gates. The devices perform the Boolean functions $Y = A \oplus B$ or $Y = \bar{A}B + A\bar{B}$ in positive logic.

A common application is as a true/complement element. If one of the inputs is low, the other input is reproduced in true form at the output. If one of the inputs is high, the signal on the other input is reproduced inverted at the output.

Device Information

| PART NUMBER | PACKAGE ⁽¹⁾ | PACKAGE SIZE ⁽²⁾ | BODY SIZE ⁽³⁾ |
|-------------|------------------------|-----------------------------|--------------------------|
| SNx4ACT86 | DB (SSOP, 14) | 6.2mm × 7.8mm | 6.2mm × 5.3mm |
| | D (SOIC, 14) | 8.65mm × 6mm | 8.65mm × 3.9mm |
| | N (PDIP, 14) | 19.3mm × 9.4mm | 19.3mm × 6.35 mm |
| | NS (SO, 14) | 10.2mm × 7.8mm | 10.3mm × 5.3mm |
| | PW (TSSOP, 14) | 5mm × 6.4mm | 5mm × 4.4mm |
| | BQA (WQFN) | 3mm × 2.5mm | 3mm × 2.5mm |

- (1) For more information, see [Section 10](#).
- (2) The package size (length × width) is a nominal value and includes pins, where applicable.
- (3) The body size (length × width) is a nominal value and does not include pins.

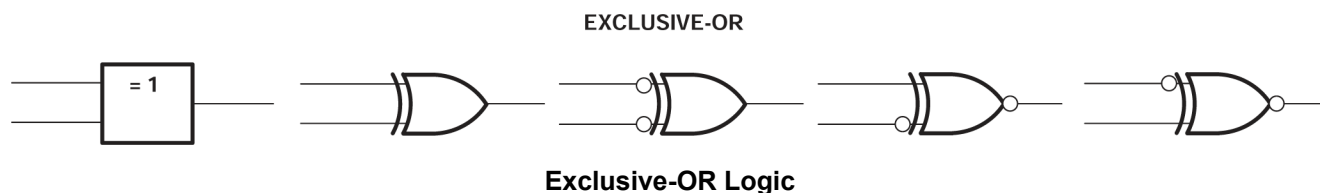
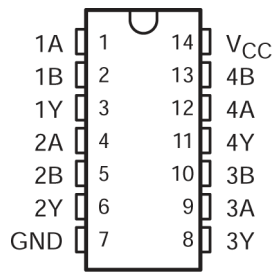

Table of Contents

| | | | |
|--|----------|--|-----------|
| 1 Features | 1 | 7 Application and Implementation | 9 |
| 2 Description | 1 | 7.1 Power Supply Recommendations..... | 9 |
| 3 Pin Configuration and Functions | 3 | 7.2 Layout..... | 9 |
| 4 Specifications | 5 | 8 Device and Documentation Support | 10 |
| 4.1 Absolute Maximum Ratings..... | 5 | 8.1 Documentation Support..... | 10 |
| 4.2 Recommended Operating Conditions..... | 5 | 8.2 Receiving Notification of Documentation Updates.... | 10 |
| 4.3 Thermal Information..... | 5 | 8.3 Support Resources..... | 10 |
| 4.4 Electrical Characteristics..... | 6 | 8.4 Trademarks..... | 10 |
| 4.5 Switching Characteristics..... | 6 | 8.5 Electrostatic Discharge Caution..... | 10 |
| 4.6 Operating Characteristics..... | 6 | 8.6 Glossary..... | 10 |
| 5 Parameter Measurement Information | 7 | 9 Revision History | 10 |
| 6 Detailed Description | 8 | 10 Mechanical, Packaging, and Orderable Information | 11 |
| 6.1 Functional Block Diagram..... | 8 | | |
| 6.2 Device Functional Modes..... | 8 | | |

3 Pin Configuration and Functions



**Figure 3-1. SN54ACT86 J or W Package;
SN74ACT86 D, DB, N, NS, or PW Package (Top
View)**

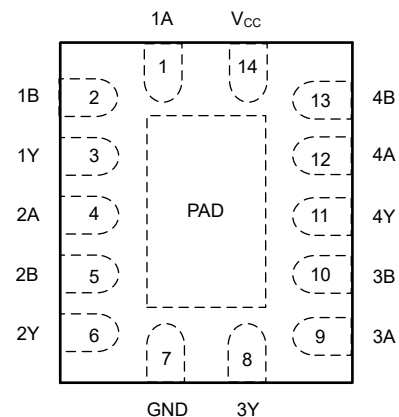

**Figure 3-2. SN74ACT86 BQA Package (Transparent
Top View)**

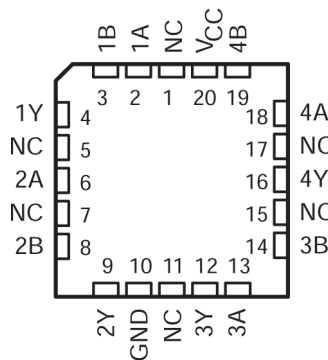

NC – No internal connection

Figure 3-3. SN54ACT86 FK Package (Top View)

Table 3-1. Pin Functions

| NAME | PIN | | Type ⁽¹⁾ | DESCRIPTION |
|-----------------|--------------------------------------|----|---------------------|---------------------|
| | BQA, D, DB, N, NS, PW, J, or W | FK | | |
| 1A | 1 | 2 | I | Channel 1, Input A |
| 1B | 2 | 3 | I | Channel 1, Input B |
| 1Y | 3 | 4 | O | Channel 1, Output Y |
| 2A | 4 | 6 | I | Channel 2, Input A |
| 2B | 5 | 8 | I | Channel 2, Input B |
| 2Y | 6 | 9 | O | Channel 2, Output Y |
| GND | 7 | 10 | G | Ground |
| 3Y | 8 | 12 | O | Channel 3, Output Y |
| 3A | 9 | 13 | I | Channel 3, Input A |
| 3B | 10 | 14 | I | Channel 3, Input B |
| 4Y | 11 | 16 | O | Channel 4, Output Y |
| 4A | 12 | 18 | I | Channel 4, Input A |
| 4B | 13 | 19 | I | Channel 4, Input B |
| V _{CC} | 14 | 20 | P | Positive Supply |

Table 3-1. Pin Functions (continued)

| PIN | | | Type ⁽¹⁾ | DESCRIPTION |
|----------------------------|--------------------------------------|------------------------|---------------------|--|
| NAME | BQA, D, DB, N, NS, PW, J, or W | FK | | |
| NC | — | 1, 5, 7, 11, 15, 17 | — | Not internally connected |
| Thermal Pad ⁽²⁾ | | | — | The thermal pad can be connected to GND or left floating. Do not connect to any other signal or supply |

(1) Signal Types: I = input, O = output, G = ground, P = power.

(2) BQA Package only.

4 Specifications

4.1 Absolute Maximum Ratings

over operating free-air temperature range (unless otherwise noted)⁽¹⁾

| | | MIN | MAX | UNIT |
|---|---------------------------|---|-----------------------|---------|
| V _{CC} | Supply voltage range | -0.5 | 7 | V |
| V _I ⁽²⁾ | Input voltage range | -0.5 | V _{CC} + 0.5 | V |
| V _O ⁽²⁾ | Output voltage range | -0.5 | V _{CC} + 0.5 | V |
| I _{IK} | Input clamp current | (V _I < 0 or V _I > V _{CC}) | | ±20 mA |
| I _{OK} | Output clamp current | (V _O < 0 or V _O > V _{CC}) | | ±20 mA |
| I _O | Continuous output current | (V _O = 0 to V _{CC}) | | ±50 mA |
| Continuous current through V _{CC} or GND | | | | ±200 mA |
| T _{stg} | Storage temperature range | -65 | 150 | °C |

- (1) Stresses beyond those listed under “absolute maximum ratings” may cause permanent damage to the device. These are stress ratings only, and functional operation of the device at these or any other conditions beyond those indicated under “recommended operating conditions” is not implied. Exposure to absolute-maximum-rated conditions for extended periods may affect device reliability.
- (2) The input and output voltage ratings may be exceeded if the input and output current ratings are observed.

4.2 Recommended Operating Conditions

over operating free-air temperature range (unless otherwise noted)⁽¹⁾

| | | SN54ACT86 | | SN74ACT86 | | UNIT |
|-----------------|------------------------------------|-----------|-----------------|-----------|-----------------|------|
| | | MIN | MAX | MIN | MAX | |
| V _{CC} | Supply voltage | 4.5 | 5.5 | 4.5 | 5.5 | V |
| V _{IH} | High-level input voltage | 2 | | 2 | | V |
| V _{IL} | Low-level input voltage | | 0.8 | | 0.8 | V |
| V _I | Input voltage | 0 | V _{CC} | 0 | V _{CC} | V |
| V _O | Output voltage | 0 | V _{CC} | 0 | V _{CC} | V |
| I _{OH} | High-level output current | | -24 | | -24 | mA |
| I _{OL} | Low-level output current | | 24 | | 24 | mA |
| Δt/Δv | Input transition rise or fall rate | | 8 | | 8 | ns/V |
| T _A | Operating free-air temperature | -55 | 125 | -40 | 85 | °C |

- (1) All unused inputs of the device must be held at V_{CC} or GND to verify proper device operation. Refer to [Implications of Slow or Floating CMOS Inputs](#), application note.

4.3 Thermal Information

| THERMAL METRIC ⁽¹⁾ | | SN74ACT86 | | | | | | UNIT |
|-------------------------------|--|------------|----------|-----------|----------|----------|------------|------|
| | | BQA (WQFN) | D (SOIC) | DB (SSOP) | N (PDIP) | NS (SOP) | PW (TSSOP) | |
| | | 14 PINS | | | | | | |
| R _{θJA} | Junction-to-ambient thermal resistance | 91.3 | 119.9 | 96 | 80 | 76 | 145.7 | °C/W |
| R _{θJC(top)} | Junction-to-case (top) thermal resistance | 99.4 | — | — | — | — | — | °C/W |
| R _{θJB} | Junction-to-board thermal resistance | 60.0 | — | — | — | — | — | °C/W |
| ψ _{JT} | Junction-to-top characterization parameter | 14.5 | — | — | — | — | — | °C/W |
| ψ _{JB} | Junction-to-board characterization parameter | 60.8 | — | — | — | — | — | °C/W |

| THERMAL METRIC ⁽¹⁾ | SN74ACT86 | | | | | | | UNIT | |
|-------------------------------|--|----------|-----------|----------|----------|------------|---|------|------|
| | BQA (WQFN) | D (SOIC) | DB (SSOP) | N (PDIP) | NS (SOP) | PW (TSSOP) | | | |
| | 14 PINS | | | | | | | | |
| R _{θJC(bot)} | Junction-to-case (bottom) thermal resistance | | 37.0 | — | — | — | — | — | °C/W |

(1) For more information about traditional and new thermal metrics, see the [Semiconductor and IC Package Thermal Metrics](#) application note.

4.4 Electrical Characteristics

over recommended operating free-air temperature range (unless otherwise noted)

| PARAMETER | TEST CONDITIONS | V _{CC} | T _A = 25 °C | | | SN54ACT86 | | SN74ACT86 | | UNIT |
|--|---|-----------------|------------------------|-------|------|-----------|------|-----------|------|------|
| | | | MIN | TYP | MAX | MIN | MAX | MIN | MAX | |
| V _{OH} | I _{OH} = -50µA | 4.5V | 4.4 | 4.49 | | 4.4 | | 4.4 | V | |
| | | 5.5V | 5.4 | 5.49 | | 5.4 | | 5.4 | | |
| | I _{OH} = -24mA | 4.5V | 3.86 | | | 3.7 | | 3.76 | | |
| | | 5.5V | 4.86 | | | 4.7 | | 4.76 | | |
| | I _{OH} = -50mA ⁽¹⁾ | 5.5V | | | | 3.85 | | | | |
| I _{OH} = -75mA ⁽¹⁾ | 5.5V | | | | | | 3.85 | | | |
| V _{OL} | I _{OL} = 50µA | 4.5V | | 0.001 | 0.1 | | 0.1 | | 0.1 | |
| | | 5.5V | | 0.001 | 0.1 | | 0.1 | | 0.1 | |
| | I _{OL} = 24mA | 4.5V | | | 0.36 | | 0.5 | | 0.44 | |
| | | 5.5V | | | 0.36 | | 0.5 | | 0.44 | |
| | I _{OL} = 50mA ⁽¹⁾ | 5.5V | | | | | 1.65 | | | |
| I _{OL} = 75mA ⁽¹⁾ | 5.5V | | | | | | | 1.65 | | |
| I _I | V _I = V _{CC} or GND | 5.5V | | | ±0.1 | | ±1 | | ±1 | µA |
| I _{CC} | V _I = V _{CC} or GND, I _O = 0 | 5.5V | | | 4 | | 80 | | 40 | µA |
| ΔI _{CC} ⁽²⁾ | One input at 3.4V, Other inputs at GND or V _{CC} | 5.5V | | | 0.6 | | 1.6 | | 1.5 | mA |
| C _i | V _I = V _{CC} or GND | 5V | | | 2.6 | | | | | pF |

(1) Not more than one output should be tested at a time, and the duration of the test should not exceed 10ms.
 (2) This is the increase in supply current for each input that is at one of the specified TTL voltage levels, rather than 0V or V_{CC}.

4.5 Switching Characteristics

over recommended operating free-air temperature range, V_{CC} = 5V ± 0.5V (unless otherwise noted) (see [Load Circuit and Voltage Waveforms](#))

| PARAMETER | FROM (INPUT) | TO (OUTPUT) | T _A = 25°C | | | SN54ACT86 | | SN74ACT86 | | UNIT |
|------------------|--------------|-------------|-----------------------|-----|-----|-----------|------|-----------|------|------|
| | | | MIN | TYP | MAX | MIN | MAX | MIN | MAX | |
| t _{PLH} | A or B | Y | 1.5 | 8.5 | 9.5 | 1 | 10 | 1 | 10 | ns |
| t _{PHL} | | | 1.5 | 7 | 9.5 | 1 | 10.5 | 1 | 10.5 | |

4.6 Operating Characteristics

V_{CC} = 5V, T_A = 25°C

| PARAMETER | TEST CONDITIONS | TYP | UNIT |
|-----------------|---|-----|------|
| C _{pd} | Power dissipation capacitance C _L = 50pF f = 1MHz | 25 | pF |

5 Parameter Measurement Information

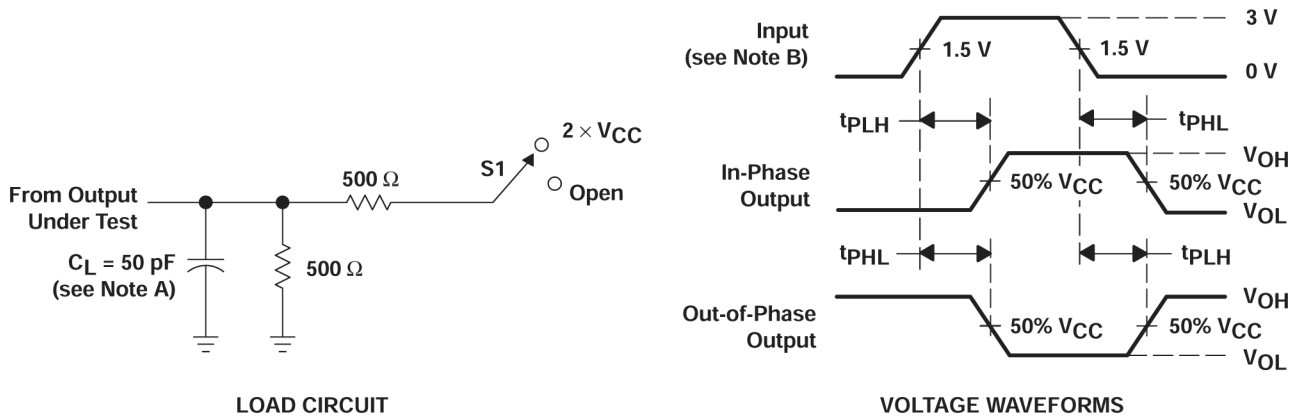

- A. C_L includes probe and jig capacitance.
- B. All input pulses are supplied by generators having the following characteristics: $PRR \leq 1\text{MHz}$, $Z_O = 50\Omega$, $t_r \leq 2.5\text{ns}$, $t_f \leq 2.5\text{ns}$.
- C. The outputs are measured one at a time with one input transition per measurement.

Figure 5-1. Load Circuit and Voltage Waveforms

| TEST | S1 |
|-------------------|------|
| t_{PLH}/t_{PHL} | Open |

6 Detailed Description

6.1 Functional Block Diagram

An exclusive-OR gate has many applications, some of which can be represented better by alternative logic symbols.



Figure 6-1. Exclusive-OR Logic

These five equivalent exclusive-OR symbols are valid for an 'ACT86 gate in positive logic; negation may be shown at any two ports.

LOGIC-IDENTITY ELEMENT

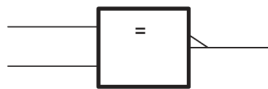

The output is active (low) if all inputs stand at the same logic level (i.e., $A = B$).

EVEN-PARITY ELEMENT

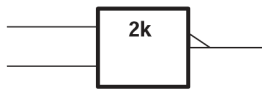

The output is active (low) if an even number of inputs (i.e., 0 or 2) are active.

ODD-PARITY ELEMENT

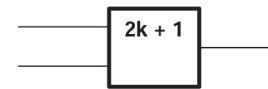

The output is active (high) if an odd number of inputs (i.e., only 1 of the 2) are active.

6.2 Device Functional Modes

Table 6-1. Function Table (Each Gate)

| INPUTS | | OUTPUT Y |
|--------|---|----------|
| A | B | |
| L | L | L |
| L | H | H |
| H | L | H |
| H | H | L |

7 Application and Implementation

Note

Information in the following applications sections is not part of the TI component specification, and TI does not warrant its accuracy or completeness. TI's customers are responsible for determining suitability of components for their purposes, as well as validating and testing their design implementation to confirm system functionality.

7.1 Power Supply Recommendations

The power supply can be any voltage between the minimum and maximum supply voltage rating located in the [Recommended Operating Conditions](#). Each V_{CC} terminal should have a bypass capacitor to prevent power disturbance. A 0.1- μF capacitor is recommended for this device. It is acceptable to parallel multiple bypass caps to reject different frequencies of noise. The 0.1- μF and 1- μF capacitors are commonly used in parallel. The bypass capacitor should be installed as close to the power terminal as possible for best results, as shown in [Figure 7-1](#).

7.2 Layout

7.2.1 Layout Guidelines

When using multiple-input and multiple-channel logic devices inputs must not ever be left floating. In many cases, functions or parts of functions of digital logic devices are unused; for example, when only two inputs of a triple-input AND gate are used. Such unused input pins must not be left unconnected because the undefined voltages at the outside connections result in undefined operational states. All unused inputs of digital logic devices must be connected to a logic high or logic low voltage, as defined by the input voltage specifications, to prevent them from floating. The logic level that must be applied to any particular unused input depends on the function of the device. Generally, the inputs are tied to GND or V_{CC} , whichever makes more sense for the logic function or is more convenient.

7.2.2 Layout Example

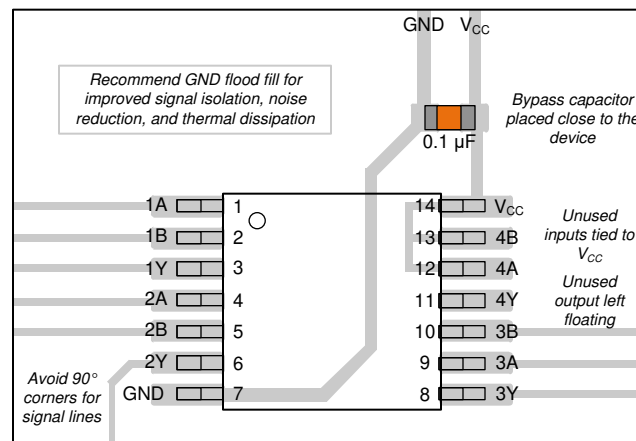

Figure 7-1. Example Layout for the SN74ACT86

8 Device and Documentation Support

8.1 Documentation Support

8.1.1 Related Links

The table below lists quick access links. Categories include technical documents, support and community resources, tools and software, and quick access to sample or buy.

| PARTS | PRODUCT FOLDER | SAMPLE & BUY | TECHNICAL DOCUMENTS | TOOLS & SOFTWARE | SUPPORT & COMMUNITY |
|-----------|----------------------------|----------------------------|----------------------------|----------------------------|----------------------------|
| SN54ACT86 | Click here | Click here | Click here | Click here | Click here |
| SN74ACT86 | Click here | Click here | Click here | Click here | Click here |

8.2 Receiving Notification of Documentation Updates

To receive notification of documentation updates, navigate to the device product folder on ti.com. Click on *Notifications* to register and receive a weekly digest of any product information that has changed. For change details, review the revision history included in any revised document.

8.3 Support Resources

TI E2E™ [support forums](#) are an engineer's go-to source for fast, verified answers and design help — straight from the experts. Search existing answers or ask your own question to get the quick design help you need.

Linked content is provided "AS IS" by the respective contributors. They do not constitute TI specifications and do not necessarily reflect TI's views; see TI's [Terms of Use](#).

8.4 Trademarks

TI E2E™ is a trademark of Texas Instruments.

All trademarks are the property of their respective owners.

8.5 Electrostatic Discharge Caution



This integrated circuit can be damaged by ESD. Texas Instruments recommends that all integrated circuits be handled with appropriate precautions. Failure to observe proper handling and installation procedures can cause damage.

ESD damage can range from subtle performance degradation to complete device failure. Precision integrated circuits may be more susceptible to damage because very small parametric changes could cause the device not to meet its published specifications.

8.6 Glossary

[TI Glossary](#) This glossary lists and explains terms, acronyms, and definitions.

9 Revision History

NOTE: Page numbers for previous revisions may differ from page numbers in the current version.

| Changes from Revision D (July 2024) to Revision E (April 2025) | Page |
|--|------|
| • Added BQA Package..... | 3 |
| • Added BQA thermal information..... | 5 |

| Changes from Revision C (October 2003) to Revision D (July 2024) | Page |
|--|------|
| • Added <i>Device Information</i> table, <i>Pin Functions</i> table, <i>Thermal Information</i> table, <i>Device Functional Modes</i> , Application and Implementation section, <i>Device and Documentation Support</i> section, and <i>Mechanical, Packaging, and Orderable Information</i> section | 1 |
| • Updated RθJA values: D = 86 to 119.9, PW = 113 to 145.7, all values in °C/W..... | 5 |

10 Mechanical, Packaging, and Orderable Information

The following pages include mechanical, packaging, and orderable information. This information is the most current data available for the designated devices. This data is subject to change without notice and revision of this document. For browser-based versions of this data sheet, refer to the left-hand navigation.

PACKAGING INFORMATION

| Orderable part number | Status (1) | Material type (2) | Package Pins | Package qty Carrier | RoHS (3) | Lead finish/ Ball material (4) | MSL rating/ Peak reflow (5) | Op temp (°C) | Part marking (6) |
|---------------------------------|---------------|----------------------|-----------------|-----------------------|-------------|--------------------------------------|-----------------------------------|--------------|---|
| 5962-9068701Q2A | Active | Production | LCCC (FK) 20 | 55 TUBE | No | SNPB | N/A for Pkg Type | -55 to 125 | 5962- 9068701Q2A SNJ54ACT 86FK |
| 5962-9068701QCA | Active | Production | CDIP (J) 14 | 25 TUBE | No | SNPB | N/A for Pkg Type | -55 to 125 | 5962-9068701QC A SNJ54ACT86J |
| 5962-9068701QDA | Active | Production | CFP (W) 14 | 25 TUBE | No | SNPB | N/A for Pkg Type | -55 to 125 | 5962-9068701QD A SNJ54ACT86W |
| SN74ACT86BQAR | Active | Production | WQFN (BQA) 14 | 3000 LARGE T&R | Yes | NIPDAU | Level-1-260C-UNLIM | -40 to 85 | AD86 |
| SN74ACT86BQAR.A | Active | Production | WQFN (BQA) 14 | 3000 LARGE T&R | Yes | NIPDAU | Level-1-260C-UNLIM | -40 to 85 | AD86 |
| SN74ACT86D | Obsolete | Production | SOIC (D) 14 | - | - | Call TI | Call TI | -40 to 85 | ACT86 |
| SN74ACT86DBR | Active | Production | SSOP (DB) 14 | 2000 LARGE T&R | Yes | NIPDAU | Level-1-260C-UNLIM | -40 to 85 | AD86 |
| SN74ACT86DBR.A | Active | Production | SSOP (DB) 14 | 2000 LARGE T&R | Yes | NIPDAU | Level-1-260C-UNLIM | -40 to 85 | AD86 |
| SN74ACT86DR | Active | Production | SOIC (D) 14 | 2500 LARGE T&R | Yes | NIPDAU | Level-1-260C-UNLIM | -40 to 85 | ACT86 |
| SN74ACT86DR.A | Active | Production | SOIC (D) 14 | 2500 LARGE T&R | Yes | NIPDAU | Level-1-260C-UNLIM | -40 to 85 | ACT86 |
| SN74ACT86DRG4 | Active | Production | SOIC (D) 14 | 2500 LARGE T&R | Yes | NIPDAU | Level-1-260C-UNLIM | -40 to 85 | ACT86 |
| SN74ACT86DRG4.A | Active | Production | SOIC (D) 14 | 2500 LARGE T&R | Yes | NIPDAU | Level-1-260C-UNLIM | -40 to 85 | ACT86 |
| SN74ACT86N | Active | Production | PDIP (N) 14 | 25 TUBE | Yes | NIPDAU | N/A for Pkg Type | -40 to 85 | SN74ACT86N |
| SN74ACT86N.A | Active | Production | PDIP (N) 14 | 25 TUBE | Yes | NIPDAU | N/A for Pkg Type | -40 to 85 | SN74ACT86N |
| SN74ACT86NSR | NRND | Production | SOP (NS) 14 | 2000 LARGE T&R | Yes | NIPDAU | Level-1-260C-UNLIM | -40 to 85 | ACT86 |
| SN74ACT86NSR.A | NRND | Production | SOP (NS) 14 | 2000 LARGE T&R | Yes | NIPDAU | Level-1-260C-UNLIM | -40 to 85 | ACT86 |
| SN74ACT86PW | Obsolete | Production | TSSOP (PW) 14 | - | - | Call TI | Call TI | -40 to 85 | AD86 |
| SN74ACT86PWR | Active | Production | TSSOP (PW) 14 | 2000 LARGE T&R | Yes | NIPDAU SN | Level-1-260C-UNLIM | -40 to 85 | AD86 |
| SN74ACT86PWR.A | Active | Production | TSSOP (PW) 14 | 2000 LARGE T&R | Yes | NIPDAU | Level-1-260C-UNLIM | -40 to 85 | AD86 |
| SN74ACT86PWRG4 | Active | Production | TSSOP (PW) 14 | 2000 LARGE T&R | Yes | NIPDAU | Level-1-260C-UNLIM | -40 to 85 | AD86 |
| SN74ACT86PWRG4.A | Active | Production | TSSOP (PW) 14 | 2000 LARGE T&R | Yes | NIPDAU | Level-1-260C-UNLIM | -40 to 85 | AD86 |
| SNJ54ACT86FK | Active | Production | LCCC (FK) 20 | 55 TUBE | No | SNPB | N/A for Pkg Type | -55 to 125 | 5962- 9068701Q2A SNJ54ACT 86FK |

| Orderable part number | Status (1) | Material type (2) | Package Pins | Package qty Carrier | RoHS (3) | Lead finish/ Ball material (4) | MSL rating/ Peak reflow (5) | Op temp (°C) | Part marking (6) |
|-----------------------------|---------------|----------------------|----------------|-----------------------|-------------|--------------------------------------|-----------------------------------|--------------|-------------------------------------|
| SNJ54ACT86FK.A | Active | Production | LCCC (FK) 20 | 55 TUBE | No | SNPB | N/A for Pkg Type | -55 to 125 | 5962-9068701Q2A SNJ54ACT 86FK |
| SNJ54ACT86J | Active | Production | CDIP (J) 14 | 25 TUBE | No | SNPB | N/A for Pkg Type | -55 to 125 | 5962-9068701QC A SNJ54ACT86J |
| SNJ54ACT86J.A | Active | Production | CDIP (J) 14 | 25 TUBE | No | SNPB | N/A for Pkg Type | -55 to 125 | 5962-9068701QC A SNJ54ACT86J |
| SNJ54ACT86W | Active | Production | CFP (W) 14 | 25 TUBE | No | SNPB | N/A for Pkg Type | -55 to 125 | 5962-9068701QD A SNJ54ACT86W |
| SNJ54ACT86W.A | Active | Production | CFP (W) 14 | 25 TUBE | No | SNPB | N/A for Pkg Type | -55 to 125 | 5962-9068701QD A SNJ54ACT86W |

(1) **Status:** For more details on status, see our [product life cycle](#).

(2) **Material type:** When designated, preproduction parts are prototypes/experimental devices, and are not yet approved or released for full production. Testing and final process, including without limitation quality assurance, reliability performance testing, and/or process qualification, may not yet be complete, and this item is subject to further changes or possible discontinuation. If available for ordering, purchases will be subject to an additional waiver at checkout, and are intended for early internal evaluation purposes only. These items are sold without warranties of any kind.

(3) **RoHS values:** Yes, No, RoHS Exempt. See the [TI RoHS Statement](#) for additional information and value definition.

(4) **Lead finish/Ball material:** Parts may have multiple material finish options. Finish options are separated by a vertical ruled line. Lead finish/Ball material values may wrap to two lines if the finish value exceeds the maximum column width.

(5) **MSL rating/Peak reflow:** The moisture sensitivity level ratings and peak solder (reflow) temperatures. In the event that a part has multiple moisture sensitivity ratings, only the lowest level per JEDEC standards is shown. Refer to the shipping label for the actual reflow temperature that will be used to mount the part to the printed circuit board.

(6) **Part marking:** There may be an additional marking, which relates to the logo, the lot trace code information, or the environmental category of the part.

Multiple part markings will be inside parentheses. Only one part marking contained in parentheses and separated by a "-" will appear on a part. If a line is indented then it is a continuation of the previous line and the two combined represent the entire part marking for that device.

Important Information and Disclaimer: The information provided on this page represents TI's knowledge and belief as of the date that it is provided. TI bases its knowledge and belief on information provided by third parties, and makes no representation or warranty as to the accuracy of such information. Efforts are underway to better integrate information from third parties. TI has taken and continues to take reasonable steps to provide representative and accurate information but may not have conducted destructive testing or chemical analysis on incoming materials and chemicals. TI and TI suppliers consider certain information to be proprietary, and thus CAS numbers and other limited information may not be available for release.

In no event shall TI's liability arising out of such information exceed the total purchase price of the TI part(s) at issue in this document sold by TI to Customer on an annual basis.

OTHER QUALIFIED VERSIONS OF SN54ACT86, SN74ACT86 :

- Catalog : [SN74ACT86](#)
- Automotive : [SN74ACT86-Q1](#), [SN74ACT86-Q1](#)
- Military : [SN54ACT86](#)

NOTE: Qualified Version Definitions:

- Catalog - TI's standard catalog product
- Automotive - Q100 devices qualified for high-reliability automotive applications targeting zero defects
- Military - QML certified for Military and Defense Applications

TAPE AND REEL INFORMATION

QUADRANT ASSIGNMENTS FOR PIN 1 ORIENTATION IN TAPE



*All dimensions are nominal

| Device | Package Type | Package Drawing | Pins | SPQ | Reel Diameter (mm) | Reel Width W1 (mm) | A0 (mm) | B0 (mm) | K0 (mm) | P1 (mm) | W (mm) | Pin1 Quadrant |
|----------------|--------------|-----------------|------|------|--------------------|--------------------|---------|---------|---------|---------|--------|---------------|
| SN74ACT86BQAR | WQFN | BQA | 14 | 3000 | 180.0 | 12.4 | 2.8 | 3.3 | 1.1 | 4.0 | 12.0 | Q1 |
| SN74ACT86DBR | SSOP | DB | 14 | 2000 | 330.0 | 16.4 | 8.35 | 6.6 | 2.4 | 12.0 | 16.0 | Q1 |
| SN74ACT86NSR | SOP | NS | 14 | 2000 | 330.0 | 16.4 | 8.1 | 10.4 | 2.5 | 12.0 | 16.0 | Q1 |
| SN74ACT86PWR | TSSOP | PW | 14 | 2000 | 330.0 | 12.4 | 6.9 | 5.6 | 1.6 | 8.0 | 12.0 | Q1 |
| SN74ACT86PWRG4 | TSSOP | PW | 14 | 2000 | 330.0 | 12.4 | 6.9 | 5.6 | 1.6 | 8.0 | 12.0 | Q1 |

TAPE AND REEL BOX DIMENSIONS

*All dimensions are nominal

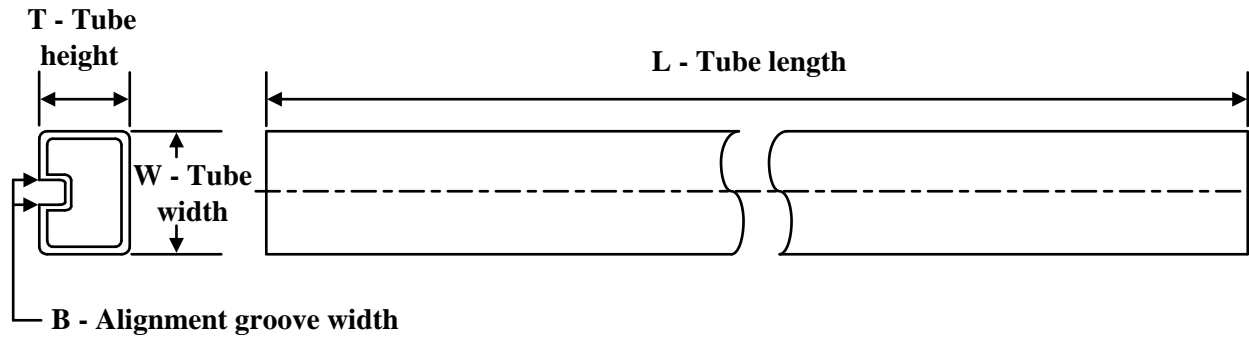
| Device | Package Type | Package Drawing | Pins | SPQ | Length (mm) | Width (mm) | Height (mm) |
|----------------|--------------|-----------------|------|------|-------------|------------|-------------|
| SN74ACT86BQAR | WQFN | BQA | 14 | 3000 | 210.0 | 185.0 | 35.0 |
| SN74ACT86DBR | SSOP | DB | 14 | 2000 | 353.0 | 353.0 | 32.0 |
| SN74ACT86NSR | SOP | NS | 14 | 2000 | 353.0 | 353.0 | 32.0 |
| SN74ACT86PWR | TSSOP | PW | 14 | 2000 | 353.0 | 353.0 | 32.0 |
| SN74ACT86PWRG4 | TSSOP | PW | 14 | 2000 | 353.0 | 353.0 | 32.0 |

TUBE

*All dimensions are nominal

| Device | Package Name | Package Type | Pins | SPQ | L (mm) | W (mm) | T (μm) | B (mm) |
|-----------------|--------------|--------------|------|-----|--------|--------|--------|--------|
| 5962-9068701Q2A | FK | LCCC | 20 | 55 | 506.98 | 12.06 | 2030 | NA |
| 5962-9068701QDA | W | CFP | 14 | 25 | 506.98 | 26.16 | 6220 | NA |
| SN74ACT86N | N | PDIP | 14 | 25 | 506 | 13.97 | 11230 | 4.32 |
| SN74ACT86N | N | PDIP | 14 | 25 | 506 | 13.97 | 11230 | 4.32 |
| SN74ACT86N.A | N | PDIP | 14 | 25 | 506 | 13.97 | 11230 | 4.32 |
| SN74ACT86N.A | N | PDIP | 14 | 25 | 506 | 13.97 | 11230 | 4.32 |
| SNJ54ACT86FK | FK | LCCC | 20 | 55 | 506.98 | 12.06 | 2030 | NA |
| SNJ54ACT86FK.A | FK | LCCC | 20 | 55 | 506.98 | 12.06 | 2030 | NA |
| SNJ54ACT86W | W | CFP | 14 | 25 | 506.98 | 26.16 | 6220 | NA |
| SNJ54ACT86W.A | W | CFP | 14 | 25 | 506.98 | 26.16 | 6220 | NA |

D0014A



PACKAGE OUTLINE

SOIC - 1.75 mm max height

SMALL OUTLINE INTEGRATED CIRCUIT

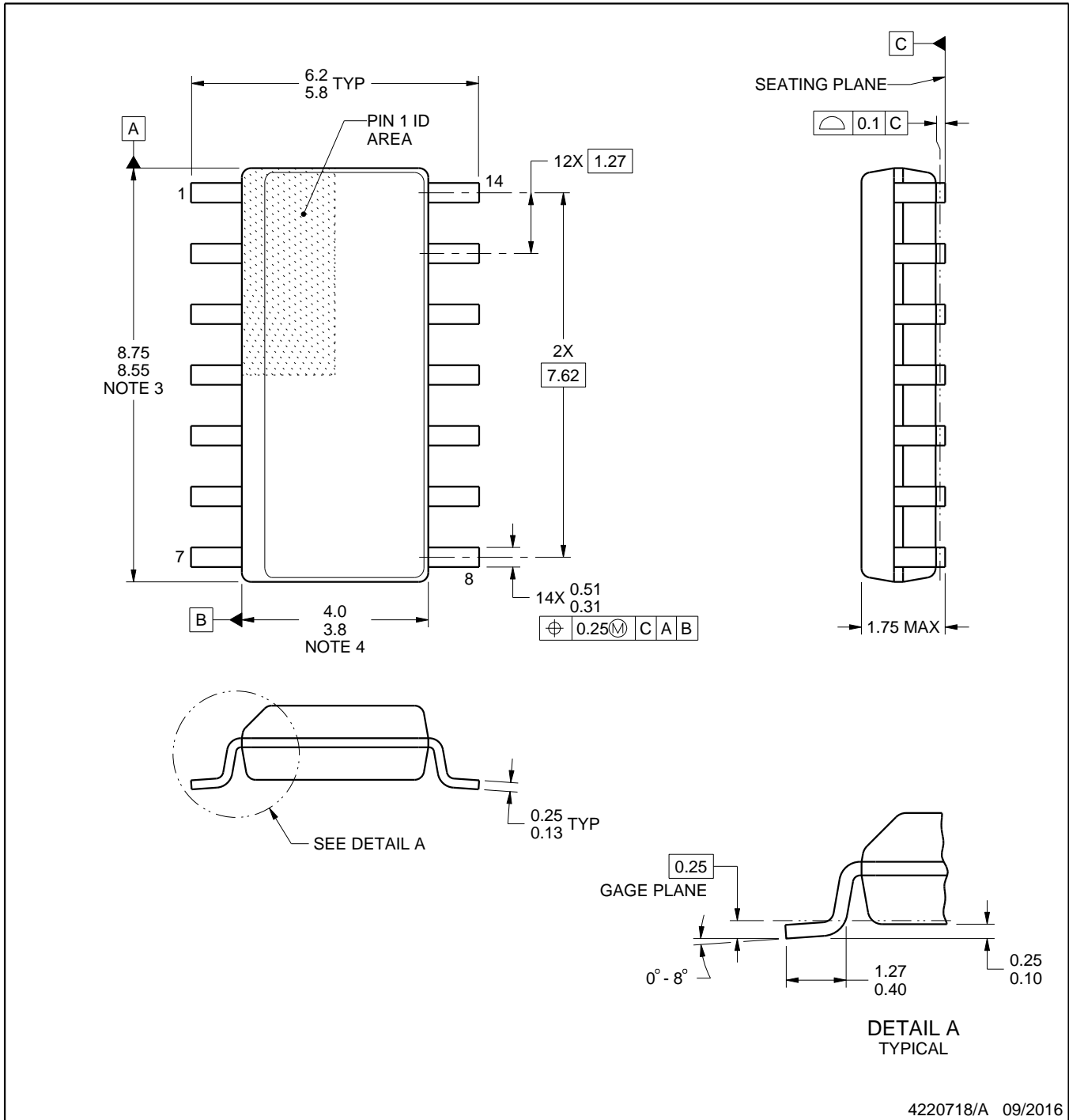

4220718/A 09/2016

EXAMPLE BOARD LAYOUT

D0014A

SOIC - 1.75 mm max height

SMALL OUTLINE INTEGRATED CIRCUIT



LAND PATTERN EXAMPLE
SCALE:8X



SOLDER MASK DETAILS

4220718/A 09/2016

NOTES: (continued)

- 6. Publication IPC-7351 may have alternate designs.
- 7. Solder mask tolerances between and around signal pads can vary based on board fabrication site.

EXAMPLE STENCIL DESIGN

D0014A

SOIC - 1.75 mm max height

SMALL OUTLINE INTEGRATED CIRCUIT



SOLDER PASTE EXAMPLE
BASED ON 0.125 mm THICK STENCIL
SCALE:8X

4220718/A 09/2016

NOTES: (continued)

8. Laser cutting apertures with trapezoidal walls and rounded corners may offer better paste release. IPC-7525 may have alternate design recommendations.
9. Board assembly site may have different recommendations for stencil design.

GENERIC PACKAGE VIEW

BQA 14

WQFN - 0.8 mm max height

2.5 x 3, 0.5 mm pitch

PLASTIC QUAD FLATPACK - NO LEAD

This image is a representation of the package family, actual package may vary.
Refer to the product data sheet for package details.

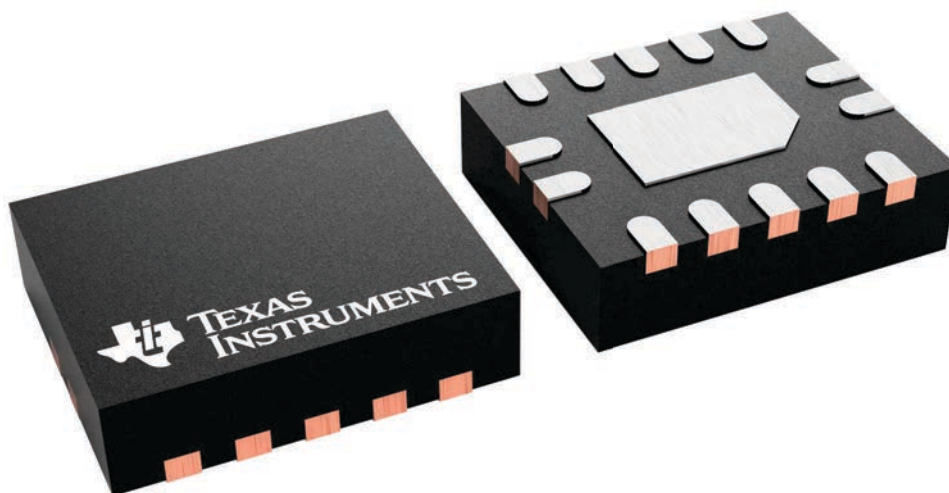

4227145/A

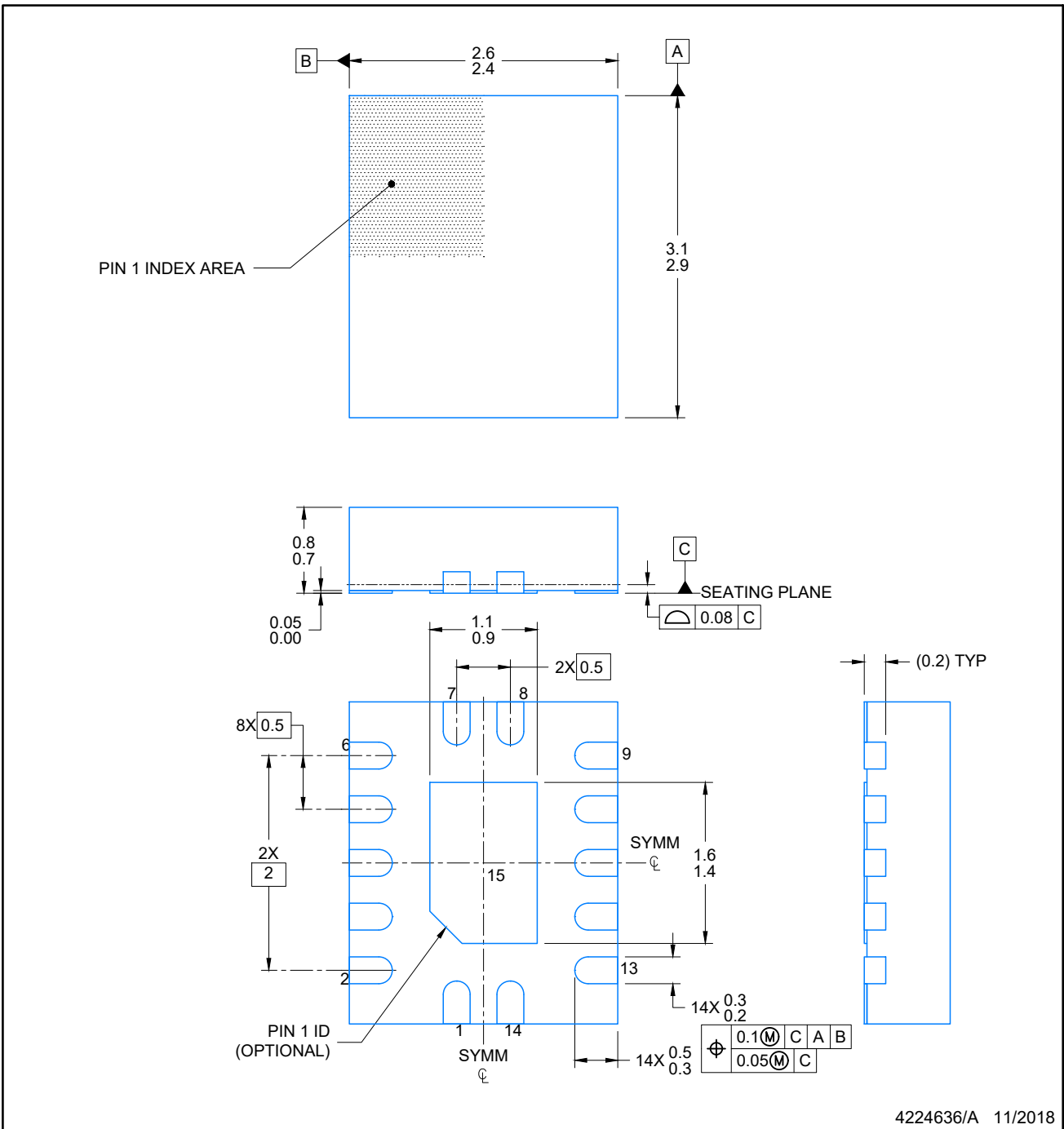

NOTES:

1. All linear dimensions are in millimeters. Any dimensions in parenthesis are for reference only. Dimensioning and tolerancing per ASME Y14.5M.
2. This drawing is subject to change without notice.
3. The package thermal pad must be soldered to the printed circuit board for optimal thermal and mechanical performance.

EXAMPLE BOARD LAYOUT

BQA0014A

WQFN - 0.8 mm max height

PLASTIC QUAD FLAT PACK-NO LEAD



LAND PATTERN EXAMPLE
EXPOSED METAL SHOWN
SCALE: 20X

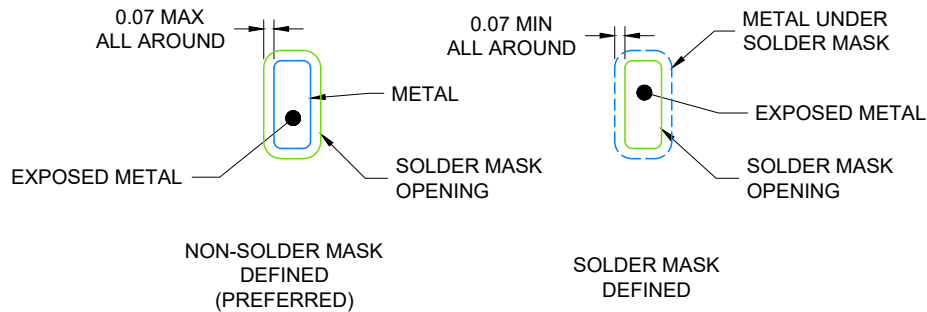

4224636/A 11/2018

NOTES: (continued)

4. This package is designed to be soldered to a thermal pad on the board. For more information, see Texas Instruments literature number SLUA271 (www.ti.com/lit/slua271).
5. Vias are optional depending on application, refer to device data sheet. If any vias are implemented, refer to their locations shown on this view. It is recommended that vias under paste be filled, plugged or tented.

EXAMPLE STENCIL DESIGN

BQA0014A

WQFN - 0.8 mm max height

PLASTIC QUAD FLAT PACK-NO LEAD



SOLDER PASTE EXAMPLE
BASED ON 0.125 mm THICK STENCIL

EXPOSED PAD
88% PRINTED COVERAGE BY AREA
SCALE: 20X

4224636/A 11/2018

NOTES: (continued)

- 6. Laser cutting apertures with trapezoidal walls and rounded corners may offer better paste release. IPC-7525 may have alternate design recommendations.

MECHANICAL DATA

NS (R-PDSO-G**)

PLASTIC SMALL-OUTLINE PACKAGE

14-PINS SHOWN



- NOTES:
- A. All linear dimensions are in millimeters.
 - B. This drawing is subject to change without notice.
 - C. Body dimensions do not include mold flash or protrusion, not to exceed 0,15.

W (R-GDFP-F14)

CERAMIC DUAL FLATPACK



4040180-2/F 04/14

- NOTES:
- A. All linear dimensions are in inches (millimeters).
 - B. This drawing is subject to change without notice.
 - C. This package can be hermetically sealed with a ceramic lid using glass frit.
 - D. Index point is provided on cap for terminal identification only.
 - E. Falls within MIL STD 1835 GDFP1-F14

DB0014A

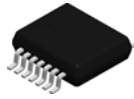

PACKAGE OUTLINE

SSOP - 2 mm max height

SMALL OUTLINE PACKAGE



NOTES:

1. All linear dimensions are in millimeters. Any dimensions in parenthesis are for reference only. Dimensioning and tolerancing per ASME Y14.5M.
2. This drawing is subject to change without notice.
3. This dimension does not include mold flash, protrusions, or gate burrs. Mold flash, protrusions, or gate burrs shall not exceed 0.15 mm per side.
4. Reference JEDEC registration MO-150.

EXAMPLE BOARD LAYOUT

DB0014A

SSOP - 2 mm max height

SMALL OUTLINE PACKAGE



LAND PATTERN EXAMPLE
EXPOSED METAL SHOWN
SCALE: 10X



4220762/A 05/2024

NOTES: (continued)

- 5. Publication IPC-7351 may have alternate designs.
- 6. Solder mask tolerances between and around signal pads can vary based on board fabrication site.

EXAMPLE STENCIL DESIGN

DB0014A

SSOP - 2 mm max height

SMALL OUTLINE PACKAGE



SOLDER PASTE EXAMPLE
BASED ON 0.125 mm THICK STENCIL
SCALE: 10X

4220762/A 05/2024

NOTES: (continued)

7. Laser cutting apertures with trapezoidal walls and rounded corners may offer better paste release. IPC-7525 may have alternate design recommendations.
8. Board assembly site may have different recommendations for stencil design.

GENERIC PACKAGE VIEW

FK 20

LCCC - 2.03 mm max height

8.89 x 8.89, 1.27 mm pitch

LEADLESS CERAMIC CHIP CARRIER

This image is a representation of the package family, actual package may vary.
Refer to the product data sheet for package details.

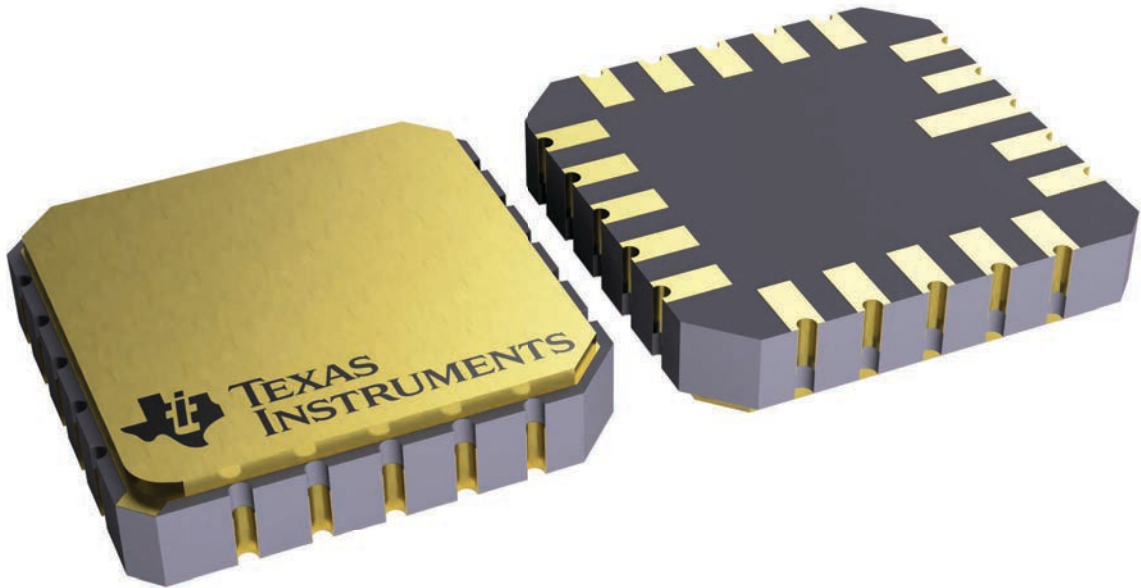

4229370VA\

J 14

GENERIC PACKAGE VIEW
CDIP - 5.08 mm max height
CERAMIC DUAL IN LINE PACKAGE



Images above are just a representation of the package family, actual package may vary.
Refer to the product data sheet for package details.

4040083-5/G

J0014A



PACKAGE OUTLINE

CDIP - 5.08 mm max height

CERAMIC DUAL IN LINE PACKAGE



4214771/A 05/2017

NOTES:

1. All controlling linear dimensions are in inches. Dimensions in brackets are in millimeters. Any dimension in brackets or parenthesis are for reference only. Dimensioning and tolerancing per ASME Y14.5M.
2. This drawing is subject to change without notice.
3. This package is hermetically sealed with a ceramic lid using glass frit.
4. Index point is provided on cap for terminal identification only and on press ceramic glass frit seal only.
5. Falls within MIL-STD-1835 and GDIP1-T14.

EXAMPLE BOARD LAYOUT

J0014A

CDIP - 5.08 mm max height

CERAMIC DUAL IN LINE PACKAGE

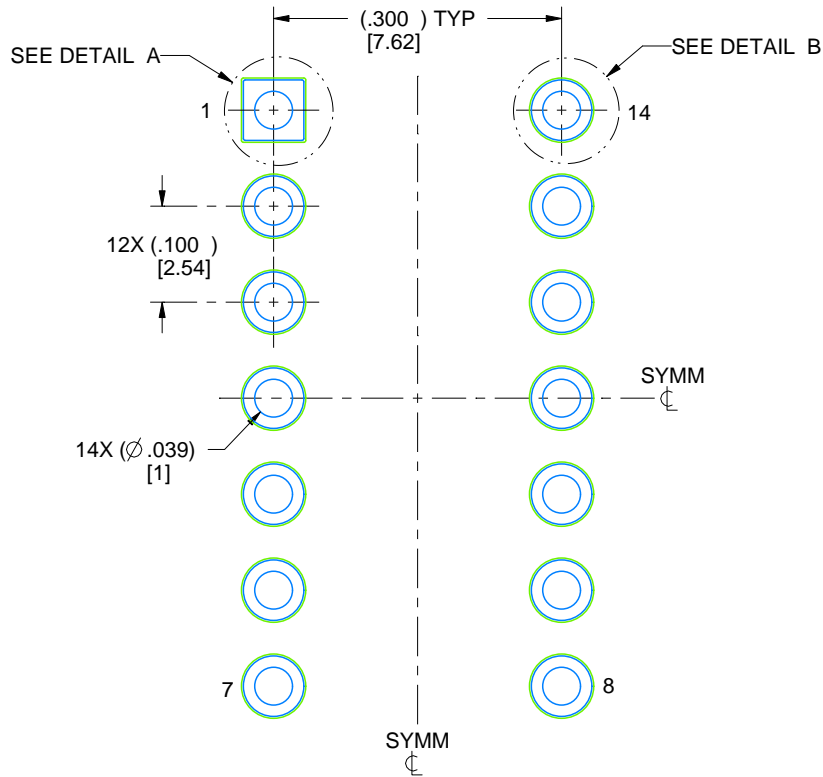

LAND PATTERN EXAMPLE
NON-SOLDER MASK DEFINED
SCALE: 5X



4214771/A 05/2017

N (R-PDIP-T**)

PLASTIC DUAL-IN-LINE PACKAGE

16 PINS SHOWN



- NOTES:
- A. All linear dimensions are in inches (millimeters).
 - B. This drawing is subject to change without notice.
 - C Falls within JEDEC MS-001, except 18 and 20 pin minimum body length (Dim A).
 - D The 20 pin end lead shoulder width is a vendor option, either half or full width.

4040049/E 12/2002

EXAMPLE BOARD LAYOUT

PW0014A

TSSOP - 1.2 mm max height

SMALL OUTLINE PACKAGE



LAND PATTERN EXAMPLE
EXPOSED METAL SHOWN
SCALE: 10X



4220202/B 12/2023

NOTES: (continued)

- 6. Publication IPC-7351 may have alternate designs.
- 7. Solder mask tolerances between and around signal pads can vary based on board fabrication site.

EXAMPLE STENCIL DESIGN

PW0014A

TSSOP - 1.2 mm max height

SMALL OUTLINE PACKAGE



SOLDER PASTE EXAMPLE
BASED ON 0.125 mm THICK STENCIL
SCALE: 10X

4220202/B 12/2023

NOTES: (continued)

8. Laser cutting apertures with trapezoidal walls and rounded corners may offer better paste release. IPC-7525 may have alternate design recommendations.
9. Board assembly site may have different recommendations for stencil design.

IMPORTANT NOTICE AND DISCLAIMER

TI PROVIDES TECHNICAL AND RELIABILITY DATA (INCLUDING DATASHEETS), DESIGN RESOURCES (INCLUDING REFERENCE DESIGNS), APPLICATION OR OTHER DESIGN ADVICE, WEB TOOLS, SAFETY INFORMATION, AND OTHER RESOURCES "AS IS" AND WITH ALL FAULTS, AND DISCLAIMS ALL WARRANTIES, EXPRESS AND IMPLIED, INCLUDING WITHOUT LIMITATION ANY IMPLIED WARRANTIES OF MERCHANTABILITY, FITNESS FOR A PARTICULAR PURPOSE OR NON-INFRINGEMENT OF THIRD PARTY INTELLECTUAL PROPERTY RIGHTS.

These resources are intended for skilled developers designing with TI products. You are solely responsible for (1) selecting the appropriate TI products for your application, (2) designing, validating and testing your application, and (3) ensuring your application meets applicable standards, and any other safety, security, regulatory or other requirements.

These resources are subject to change without notice. TI grants you permission to use these resources only for development of an application that uses the TI products described in the resource. Other reproduction and display of these resources is prohibited. No license is granted to any other TI intellectual property right or to any third party intellectual property right. TI disclaims responsibility for, and you fully indemnify TI and its representatives against any claims, damages, costs, losses, and liabilities arising out of your use of these resources.

TI's products are provided subject to [TI's Terms of Sale](#), [TI's General Quality Guidelines](#), or other applicable terms available either on [ti.com](#) or provided in conjunction with such TI products. TI's provision of these resources does not expand or otherwise alter TI's applicable warranties or warranty disclaimers for TI products. Unless TI explicitly designates a product as custom or customer-specified, TI products are standard, catalog, general purpose devices.

TI objects to and rejects any additional or different terms you may propose.

Copyright © 2026, Texas Instruments Incorporated

Last updated 10/2025