

# LMP860x-Q1 AEC-Q100, –22V to 60V, Bidirectional Current Sense Amplifier With In-Line Filter Capability

## 1 Features

- AEC-Q100 qualified for automotive applications:
  - Temperature grade 1: –40°C to +125°C, T<sub>A</sub>
  - Temperature grade 0: –40°C to +150°C, T<sub>A</sub> (LMP8601EDRQ1 Only)
- **Functional Safety-Capable**
  - [Documentation available to aid functional safety system design](#)
- Wide operational commonmode voltage range:
  - At V<sub>S</sub> = 3.3V: –4V to 27V
  - At V<sub>S</sub> = 5V: –22V to 60V
- CMRR: 90dB Minimum
- In-line filter capability for signal conditioning
- TCV<sub>OS</sub>: ±10µV/°C Maximum
- Input Offset Voltage: ±1mV Maximum
- Single-Supply Bidirectional Operation
- Gain = 20x for LMP8601-Q1
- Gain = 50x for LMP8602-Q1
- Gain = 100x for LMP8603-Q1

## 2 Applications

- [DC/DC converter](#)
- [Starter & Generator](#)
- [Onboard Charger](#)
- [Automotive Fuel Injection Control](#)
- [Automatic Transmission](#)
- [Power Steering](#)
- [Battery Management Systems](#)

## 3 Description

The LMP8601-Q1, LMP8602-Q1, and LMP8603-Q1 devices are fixed-gain, precision current-sense amplifiers (also referred to as current-shunt monitors). The input common-mode voltage range is –22V to +60V when operating from a single 5V supply, or –4V to +27V with a 3.3V supply. The LMP860x-Q1 are parts designed for unidirectional and bidirectional current sensing applications.

These devices have a precise gain of 20x (LMP8601-Q1), 50x (LMP8602-Q1), and 100x (LMP8603-Q1), and are adequate in most targeted applications to drive an ADC to full-scale value. The fixed gain is achieved in two separate stages: a preamplifier with a gain of 10x and an output stage buffer amplifier with a gain of 2x (LMP8601-Q1), 5x (LMP8602-Q1), or 10x (LMP8603-Q1). The path between the two stages is brought out on two pins to enable the option of an additional filter network or modifying the gain.

The offset input pin enables these devices for unidirectional or bidirectional single supply voltage current sensing.

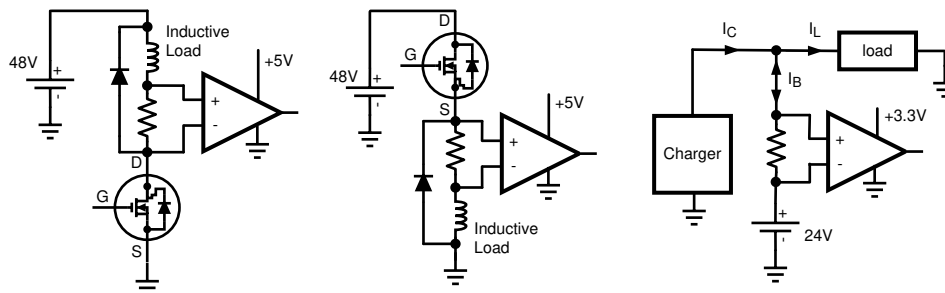
The LMP860x-Q1 devices incorporate enhanced manufacturing and support processes for the automotive market and are compliant with the AEC-Q100 standard.

### Package Information

PART NUMBER	PACKAGE <sup>(1)</sup>	PACKAGE SIZE <sup>(2)</sup>
LMP860x-Q1	D (SOIC, 8)	4.90mm × 6.00mm
LMP8602-Q1 LMP8603-Q1	DGK (VSSOP, 8)	3.00mm × 4.90mm

(1) For more information, see [Section 10](#).

(2) The package size (length × width) is a nominal value and includes pins, where applicable.



**Typical Applications**



## Table of Contents

<b>1 Features</b> .....	1	6.3 Feature Description.....	21
<b>2 Applications</b> .....	1	6.4 Device Functional Modes.....	24
<b>3 Description</b> .....	1	<b>7 Application and Implementation</b> .....	28
<b>4 Pin Configuration and Functions</b> .....	2	7.1 Typical Applications.....	28
<b>5 Specifications</b> .....	3	<b>8 Device and Documentation Support</b> .....	34
5.1 Absolute Maximum Ratings.....	3	8.1 Device Support.....	34
5.2 ESD Ratings.....	3	8.2 Documentation Support.....	34
5.3 Recommended Operating Conditions.....	3	8.3 Receiving Notification of Documentation Updates... 34	
5.4 Thermal Information.....	3	8.4 Support Resources.....	34
5.5 Electrical Characteristics: $V_s = 3.3V$ .....	4	8.5 Trademarks.....	34
5.6 Electrical Characteristics: $V_s = 5V$ .....	6	8.6 Electrostatic Discharge Caution.....	34
5.7 Typical Characteristics.....	9	8.7 Glossary.....	34
<b>6 Detailed Description</b> .....	20	<b>9 Revision History</b> .....	35
6.1 Overview.....	20	<b>10 Mechanical, Packaging, and Orderable Information</b> .....	36
6.2 Functional Block Diagram.....	20		

## 4 Pin Configuration and Functions

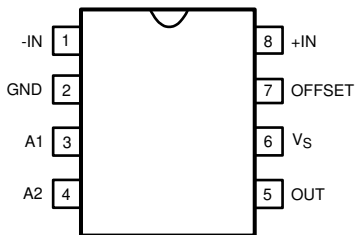


Figure 4-1. D Package 8-Pin SOIC Top View

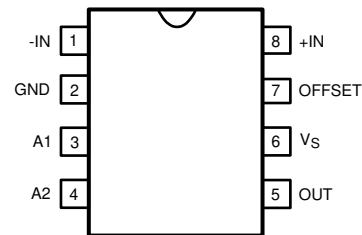


Figure 4-2. DGK Package 8-Pin VSSOP Top View

Table 4-1. Pin Functions

PIN		TYPE <sup>(1)</sup>	DESCRIPTION
NAME	NO.		
A1	3	O	Preamplifier output
A2	4	I	Input from the external filter network and, or A1
GND	2	P	Power ground
+IN	8	I	Positive input
-IN	1	I	Negative input
OFFSET	7	I	DC offset for bidirectional signals
OUT	5	O	Single-ended output
$V_s$	6	P	Positive supply voltage

(1) I = Input; O = Output; P = Power

## 5 Specifications

### 5.1 Absolute Maximum Ratings

over operating free-air temperature range (unless otherwise noted)<sup>(1)</sup>

		MIN	MAX	UNIT
Supply Voltage ( $V_S$ )	$(V_S - \text{GND})$	-0.3	6	V
Analog Inputs, $V_{\text{IN}+}$ , $V_{\text{IN}-}$ <sup>(2)</sup>	Common-mode	-25	65	V
	Differential ( $V_{\text{IN}+} - V_{\text{IN}-}$ )	-82	82	V
A1, A2, OFFSET and OUT pins		(GND - 0.3)	$(V_S + 0.3)$	V
$T_A$	Ambient temperature	-55	125	°C
$T_A$	LMP8601EDRQ1 only	-55	150	°C
$T_J$	Junction temperature		150	°C
$T_{\text{stg}}$	Storage temperature	-65	150	°C

- (1) Operation outside the Absolute Maximum Ratings may cause permanent device damage. Absolute Maximum Ratings do not imply functional operation of the device at these or any other conditions beyond those listed under Recommended Operating Conditions. If used outside the Recommended Operating Conditions but within the Absolute Maximum Ratings, the device may not be fully functional, and this may affect device reliability, functionality, performance, and shorten the device lifetime.
- (2)  $V_{\text{IN}+}$  and  $V_{\text{IN}-}$  are the voltages at the IN+ and IN- pins, respectively.

### 5.2 ESD Ratings

			VALUE	UNIT
$V_{\text{(ESD)}}$	Electrostatic discharge	Human body model (HBM), per AEC Q100-002 <sup>(1)</sup> HBM ESD classification level 2, all pins except 1 and 8	±2000	V
		Human body model (HBM), per AEC Q100-002 <sup>(1)</sup> HBM ESD classification level 3A, pins 1 and 8	±4000	
		Charged device model (CDM), per AEC Q100-011 CDM ESD classification level C6	±1000	

- (1) AEC Q100-002 indicates that HBM stressing shall be in accordance with the ANSI/ESDA/JEDEC JS-001 specification.

### 5.3 Recommended Operating Conditions

over operating free-air temperature range (unless otherwise noted)

		MIN	NOM	MAX	UNIT
$V_S$	Operating supply range	3		5.5	V
$V_{\text{OFFSET}}$	OFFSET Voltage	0		$V_S$	V
$T_A$	Ambient temperature	-40		125	°C
$T_A$	Ambient temperature, LMP8601EDRQ1	-40		150	°C

### 5.4 Thermal Information

THERMAL METRIC <sup>(1)</sup>		LMP860x-Q1	LMP8602-Q1, LMP8603-Q1	UNIT
		D (SOIC)	DGK (VSSOP)	
		8 PINS	8 PINS	
$R_{\theta\text{JA}}$	Junction-to-ambient thermal resistance	128.93	171.1	°C/W
$R_{\theta\text{JC(top)}}$	Junction-to-case (top) thermal resistance	68.3	64.1	°C/W
$R_{\theta\text{JB}}$	Junction-to-board thermal resistance	72.7	91.1	°C/W
$\Psi_{\text{JT}}$	Junction-to-top characterization parameter	17.76	9.4	°C/W

THERMAL METRIC <sup>(1)</sup>		LMP860x-Q1	LMP8602-Q1, LMP8603-Q1	UNIT
		D (SOIC)	DGK (VSSOP)	
		8 PINS	8 PINS	
$\Psi_{JB}$	Junction-to-board characterization parameter	72.07	89.7	°C/W

(1) For more information about traditional and new thermal metrics, see the [Semiconductor and IC Package Thermal Metrics](#) application note.

### 5.5 Electrical Characteristics: $V_S = 3.3V$

at  $T_A = 25^\circ C$ ,  $V_S = 3.3V$ , GND = 0V,  $V_{CM} = V_S/2$ , OFFSET = GND,  $R_L =$  No Load (unless otherwise noted)

PARAMETER		TEST CONDITIONS	MIN	TYP	MAX	UNIT
<b>INPUT</b>						
$V_{CM}$	Common-mode input range <sup>(1)</sup>	$T_A = -40^\circ C$ to $+125^\circ C$ $T_A = -40^\circ C$ to $+150^\circ C$ , LMP8601EDRQ1	-4		27	V
$R_{CM}$	Input impedance common-mode, DGK package and LMP8601EDRQ1	$-4V < V_{CM} < 27V$ ,		295		k $\Omega$
		$-4V < V_{CM} < 27V$ , $T_A = -40^\circ C$ to $+125^\circ C$ $T_A = -40^\circ C$ to $+150^\circ C$ , LMP8601EDRQ1	250		350	
$R_{DM}$	Input impedance common-mode D package	$-4V < V_{CM} < 27V$ ,		450		k $\Omega$
		$-4V < V_{CM} < 27V$ , $T_A = -40^\circ C$ to $+125^\circ C$	250		650	
$R_{DM}$	Input impedance differential-mode, DGK package and LMP8601EDRQ1	$-4V < V_{CM} < 27V$ ,		590		k $\Omega$
		$-4V < V_{CM} < 27V$ , $T_A = -40^\circ C$ to $+125^\circ C$ $T_A = -40^\circ C$ to $+150^\circ C$ , LMP8601EDRQ1	500		700	
$V_{os}$	Offset voltage, input referred	$V_{CM} = V_S / 2$ ,		$\pm 0.15$	$\pm 1$	mV
		$T_A = -40^\circ C$ to $+125^\circ C$ $T_A = -40^\circ C$ to $+150^\circ C$ , LMP8601EDRQ1	-2		2	
$dV_{os}/dT$	Offset voltage drift	$T_A = -40^\circ C$ to $+125^\circ C$ $T_A = -40^\circ C$ to $+150^\circ C$ , LMP8601EDRQ1			$\pm 10$	$\mu V/^\circ C$
PSRR	Power supply rejection ratio, input referred	$V_{CM} = V_S / 2$ , $3.0V \leq V_S \leq 3.6V$ ,		$\pm 50$		$\mu V/V$
		$T_A = -40^\circ C$ to $+125^\circ C$ $T_A = -40^\circ C$ to $+150^\circ C$ , LMP8601EDRQ1			$\pm 320$	
<b>OUTPUT</b>						
$A_V$	Total gain	LMP8601-Q1	19.9	20	20.1	V/V
		LMP8602-Q1	49.75	50	50.25	
		LMP8603-Q1	99.5	100	100.5	
$G_{ERR}$	Gain error				$\pm 0.5$	%
	Gain error drift	$T_A = -40^\circ C$ to $+125^\circ C$ $T_A = -40^\circ C$ to $+150^\circ C$ , LMP8601EDRQ1		$\pm 2.7$	$\pm 20$	ppm/ $^\circ C$
	Maximum capacitive load	No sustained oscillations, no isolation resistor			100	pF
<b>FREQUENCY RESPONSE</b>						
BW	Bandwidth			60		kHz
SR	Slew rate (Rising)	OFFSET = $V_S/2$ , $V_{Sense} = \pm 0.165V$		0.7		V/ $\mu s$
	Slew rate (Falling)	OFFSET = $V_S/2$ , $V_{Sense} = \pm 0.165V$		0.7		
<b>NOISE</b>						
$V_{en}$	Input-referred voltage noise	0.1Hz - 10Hz, 6 sigma		16.4		$\mu V_{P-P}$
		1kHz		830		nV/ $\sqrt{Hz}$
<b>POWER SUPPLY</b>						

at  $T_A = 25^\circ\text{C}$ ,  $V_S = 3.3\text{V}$ ,  $\text{GND} = 0\text{V}$ ,  $V_{\text{CM}} = V_S/2$ ,  $\text{OFFSET} = \text{GND}$ ,  $R_L = \text{No Load}$  (unless otherwise noted)

PARAMETER		TEST CONDITIONS	MIN	TYP	MAX	UNIT
I <sub>S</sub>	Supply current			1		mA
		$T_A = -40^\circ\text{C}$ to $+125^\circ\text{C}$ $T_A = -40^\circ\text{C}$ to $+150^\circ\text{C}$ , LMP8601EDRQ1	0.45		1.3	mA
<b>REFERENCE</b>						
	Midscale offset scaling accuracy (Reference Divider Accuracy)	LMP8601-Q1		±0.15	±0.50	%
		LMP8602-Q1		±0.25	±1	
		LMP8603-Q1		±0.45	±1.5	
<b>PREAMPLIFIER</b>						
CMRR	Common-mode rejection ratio, input referred	$-2\text{V} < V_{\text{CM}} < 24\text{V}$ ,		96		dB
		$-2\text{V} < V_{\text{CM}} < 24\text{V}$ , $T_A = -40^\circ\text{C}$ to $+125^\circ\text{C}$ $T_A = -40^\circ\text{C}$ to $+150^\circ\text{C}$ , LMP8601EDRQ1	86			
		$f = 1\text{kHz}$		94		
		$f = 10\text{kHz}$		85		
K1	Preamplifier gain		9.95	10.0	10.05	V/V
V <sub>os_P</sub>	Preamplifier offset voltage, input referred	$V_{\text{CM}} = V_S / 2$		±0.15	±1	mV
R <sub>F-INT</sub>	Preamplifier output impedance resistor			100		kΩ
		$T_A = -40^\circ\text{C}$ to $+125^\circ\text{C}$	99		101	
R <sub>F-INT</sub>	Preamplifier output impedance resistor	$T_A = -40^\circ\text{C}$ to $+150^\circ\text{C}$ , LMP8601EDRQ1	97		103	kΩ
TCR <sub>F-INT</sub>	Preamplifier output impedance resistor drift	$T_A = -40^\circ\text{C}$ to $+125^\circ\text{C}$ $T_A = -40^\circ\text{C}$ to $+150^\circ\text{C}$ , LMP8601EDRQ1		±5	±50	ppm/°C
A1 V <sub>OUT</sub>	Swing to V <sub>S</sub> (Power supply rail), R <sub>L</sub> = No Load			3.25		V
		$T_A = -40^\circ\text{C}$ to $+125^\circ\text{C}$ $T_A = -40^\circ\text{C}$ to $+150^\circ\text{C}$ , LMP8601EDRQ1	3.2			
A1 V <sub>OUT</sub>	Swing to ground, R <sub>L</sub> = No Load			2		mV
		$T_A = -40^\circ\text{C}$ to $+125^\circ\text{C}$ $T_A = -40^\circ\text{C}$ to $+150^\circ\text{C}$ , LMP8601EDRQ1			10	
<b>OUTPUT BUFFER</b>						
V <sub>os_B</sub>	Buffer Stage input offset voltage, input referred	$0\text{V} \leq V_{\text{CM}} \leq V_S$		±0.5	±2	mV
		$0\text{V} \leq V_{\text{CM}} \leq V_S$ , $T_A = -40^\circ\text{C}$ to $+125^\circ\text{C}$ $T_A = -40^\circ\text{C}$ to $+150^\circ\text{C}$ , LMP8601EDRQ1			±2.5	
K2	Output buffer gain	LMP8601-Q1	1.99	2	2.01	V/V
		LMP8602-Q1	4.975	5	5.025	
		LMP8603-Q1	9.95	10.0	10.05	
I <sub>B_B</sub>	Input bias current of A2			±2		pA
		$T_A = -40^\circ\text{C}$ to $+125^\circ\text{C}$ $T_A = -40^\circ\text{C}$ to $+150^\circ\text{C}$ , LMP8601EDRQ1			±20	nA
A2 V <sub>OUT</sub>	Swing to ground, R <sub>L</sub> = 100kΩ to V <sub>S</sub>	LMP8601-Q1		4		mV
		LMP8601-Q1, $T_A = -40^\circ\text{C}$ to $+125^\circ\text{C}$ $T_A = -40^\circ\text{C}$ to $+150^\circ\text{C}$ , LMP8601EDRQ1			20	
		LMP8602-Q1		10		
		LMP8602-Q1, $T_A = -40^\circ\text{C}$ to $+125^\circ\text{C}$ $T_A = -40^\circ\text{C}$ to $+150^\circ\text{C}$ , LMP8601EDRQ1			40	
		LMP8603-Q1		10		
		LMP8603-Q1, $T_A = -40^\circ\text{C}$ to $+125^\circ\text{C}$ $T_A = -40^\circ\text{C}$ to $+150^\circ\text{C}$ , LMP8601EDRQ1			80	
A2 V <sub>OUT</sub>	Swing to V <sub>S</sub> (Power supply rail), R <sub>L</sub> = 100kΩ to ground			3.29		V
		$T_A = -40^\circ\text{C}$ to $+125^\circ\text{C}$ $T_A = -40^\circ\text{C}$ to $+150^\circ\text{C}$ , LMP8601EDRQ1	3.28			

at  $T_A = 25^\circ\text{C}$ ,  $V_S = 3.3\text{V}$ ,  $\text{GND} = 0\text{V}$ ,  $V_{\text{CM}} = V_S/2$ ,  $\text{OFFSET} = \text{GND}$ ,  $R_L = \text{No Load}$  (unless otherwise noted)

PARAMETER		TEST CONDITIONS	MIN	TYP	MAX	UNIT
$I_{\text{SC}}$	Output short-circuit current	Sourcing, $V_{\text{IN}} = V_S$ , $V_{\text{OUT}} = \text{GND}$	-60	-38	-25	mA
		Sinking, $V_{\text{IN}} = \text{GND}$ , $V_{\text{OUT}} = V_S$	30	46	65	

(1) Common-mode voltage at both  $V_{\text{IN}+}$  and  $V_{\text{IN}-}$  must not exceed the specified common-mode input range.

## 5.6 Electrical Characteristics: $V_S = 5\text{V}$

at  $T_A = 25^\circ\text{C}$ ,  $V_S = 5\text{V}$ ,  $\text{GND} = 0\text{V}$ ,  $V_{\text{CM}} = V_S/2$ ,  $\text{OFFSET} = \text{GND}$ ,  $R_L = \text{No Load}$  (unless otherwise noted)

PARAMETER		TEST CONDITIONS	MIN	TYP	MAX	UNIT	
<b>INPUT</b>							
$V_{\text{CM}}$	Common-mode input range <sup>(1)</sup>	$T_A = -40^\circ\text{C}$ to $+125^\circ\text{C}$ $T_A = -40^\circ\text{C}$ to $+150^\circ\text{C}$ , LMP8601EDRQ1	-22		60	V	
$R_{\text{CM}}$	Input impedance common-mode, DGK package and LMP8601EDRQ1	$0\text{V} < V_{\text{CM}} < 60\text{V}$ ,		295		k $\Omega$	
		$0\text{V} < V_{\text{CM}} < 60\text{V}$ , $T_A = -40^\circ\text{C}$ to $+125^\circ\text{C}$ $T_A = -40^\circ\text{C}$ to $+150^\circ\text{C}$ , LMP8601EDRQ1	250		350		
		$-20\text{V} < V_{\text{CM}} < 0\text{V}$ ,		193			
		$-20\text{V} < V_{\text{CM}} < 0\text{V}$ , $T_A = -40^\circ\text{C}$ to $+125^\circ\text{C}$ $T_A = -40^\circ\text{C}$ to $+150^\circ\text{C}$ , LMP8601EDRQ1	165		250		
$R_{\text{CM}}$	Input impedance common-mode D package	$0\text{V} < V_{\text{CM}} < 60\text{V}$ ,		450		k $\Omega$	
		$0\text{V} < V_{\text{CM}} < 60\text{V}$ , $T_A = -40^\circ\text{C}$ to $+125^\circ\text{C}$	250		650		
		$-20\text{V} < V_{\text{CM}} < 0\text{V}$ ,		450			
		$-20\text{V} < V_{\text{CM}} < 0\text{V}$ , $T_A = -40^\circ\text{C}$ to $+125^\circ\text{C}$	250		650		
$R_{\text{DM}}$	Input impedance differential-mode, DGK package and LMP8601EDRQ1	$0\text{V} < V_{\text{CM}} < 60\text{V}$ ,		590		k $\Omega$	
		$0\text{V} < V_{\text{CM}} < 60\text{V}$ , $T_A = -40^\circ\text{C}$ to $+125^\circ\text{C}$ $T_A = -40^\circ\text{C}$ to $+150^\circ\text{C}$ , LMP8601EDRQ1	500		700		
		$-20\text{V} < V_{\text{CM}} < 0\text{V}$ ,		386			
		$-20\text{V} < V_{\text{CM}} < 0\text{V}$ , $T_A = -40^\circ\text{C}$ to $+125^\circ\text{C}$ $T_A = -40^\circ\text{C}$ to $+150^\circ\text{C}$ , LMP8601EDRQ1	300		500		
$R_{\text{DM}}$	Input impedance differential-mode D package	$0\text{V} < V_{\text{CM}} < 60\text{V}$ ,		900		k $\Omega$	
		$0\text{V} < V_{\text{CM}} < 60\text{V}$ , $T_A = -40^\circ\text{C}$ to $+125^\circ\text{C}$	500		1300		
		$-20\text{V} < V_{\text{CM}} < 0\text{V}$ ,		900			
		$-20\text{V} < V_{\text{CM}} < 0\text{V}$ , $T_A = -40^\circ\text{C}$ to $+125^\circ\text{C}$	500		1300		
$V_{\text{OS}}$	Offset voltage, input referred	$V_{\text{CM}} = V_S / 2$ ,		$\pm 0.15$	$\pm 1$	mV	
		$T_A = -40^\circ\text{C}$ to $+125^\circ\text{C}$ $T_A = -40^\circ\text{C}$ to $+150^\circ\text{C}$ , LMP8601EDRQ1	-2		2		
$dV_{\text{OS}}/dT$	Offset voltage drift	$T_A = -40^\circ\text{C}$ to $+125^\circ\text{C}$ $T_A = -40^\circ\text{C}$ to $+150^\circ\text{C}$ , LMP8601EDRQ1			$\pm 10$	$\mu\text{V}/^\circ\text{C}$	
PSRR	Power supply rejection ratio, input referred	$V_{\text{CM}} = V_S / 2$ , $4.5\text{V} \leq V_S \leq 5.5\text{V}$ ,		$\pm 32$		$\mu\text{V}/\text{V}$	
		$T_A = -40^\circ\text{C}$ to $+125^\circ\text{C}$ $T_A = -40^\circ\text{C}$ to $+150^\circ\text{C}$ , LMP8601EDRQ1			$\pm 320$	$\mu\text{V}/\text{V}$	
<b>OUTPUT</b>							
$A_V$	Total gain	LMP8601-Q1	19.9	20	20.1	V/V	
		LMP8602-Q1	49.75	50	50.25		
		LMP8603-Q1	99.5	100	100.5		
$G_{\text{ERR}}$	Gain error				$\pm 0.5$	%	
	Gain error drift	$T_A = -40^\circ\text{C}$ to $+125^\circ\text{C}$ $T_A = -40^\circ\text{C}$ to $+150^\circ\text{C}$ , LMP8601EDRQ1		$\pm 2.8$	$\pm 20$	ppm/ $^\circ\text{C}$	
	Maximum capacitive load	No sustained oscillations, no isolation resistor			100	pF	
<b>FREQUENCY RESPONSE</b>							

at  $T_A = 25^\circ\text{C}$ ,  $V_S = 5\text{V}$ ,  $\text{GND} = 0\text{V}$ ,  $V_{\text{CM}} = V_S/2$ ,  $\text{OFFSET} = \text{GND}$ ,  $R_L = \text{No Load}$  (unless otherwise noted)

PARAMETER		TEST CONDITIONS	MIN	TYP	MAX	UNIT
BW	Bandwidth			60		kHz
SR	Slew rate (Rising)	OFFSET = $V_S$ , $V_{\text{Sense}} = \pm 0.25\text{V}$ ,		0.83		V/ $\mu\text{s}$
	Slew rate (Falling)	OFFSET = $V_S$ , $V_{\text{Sense}} = \pm 0.25\text{V}$ ,		0.83		
<b>NOISE</b>						
Ven	Input-referred voltage noise	0.1Hz - 10Hz, 6 sigma,		17.5		$\mu\text{V}_{\text{P-P}}$
		1 kHz,		890		nV/ $\sqrt{\text{Hz}}$
<b>POWER SUPPLY</b>						
I <sub>S</sub>	Supply current			1.1		mA
		$T_A = -40^\circ\text{C}$ to $+125^\circ\text{C}$ $T_A = -40^\circ\text{C}$ to $+150^\circ\text{C}$ , LMP8601EDRQ1	0.45		1.5	
<b>REFERENCE</b>						
	Midscale offset scaling accuracy (Reference Divider Accuracy)	LMP8601-Q1		$\pm 0.15$	$\pm 0.50$	%
		LMP8602-Q1		$\pm 0.25$	$\pm 1$	
		LMP8603-Q1		$\pm 0.45$	$\pm 1.5$	
<b>PREAMPLIFIER</b>						
CMRR	Common-mode rejection ratio, input referred	$-20\text{V} < V_{\text{CM}} < 60\text{V}$ ,		105		dB
		$-20\text{V} < V_{\text{CM}} < 60\text{V}$ , $T_A = -40^\circ\text{C}$ to $+125^\circ\text{C}$ $T_A = -40^\circ\text{C}$ to $+150^\circ\text{C}$ , LMP8601EDRQ1	90			
		$f = 1\text{kHz}$		96		
		$f = 10\text{kHz}$		83		
K1	Preamplifier gain		9.95	10.0	10.05	V/V
V <sub>os_P</sub>	Preamplifier offset voltage, input referred	$V_{\text{CM}} = V_S / 2$ ,		$\pm 0.15$	$\pm 1$	mV
R <sub>F-INT</sub>	Preamplifier output impedance resistor			100		k $\Omega$
		$T_A = -40^\circ\text{C}$ to $+125^\circ\text{C}$	99		101	
R <sub>F-INT</sub>	Preamplifier output impedance resistor	$T_A = -40^\circ\text{C}$ to $+150^\circ\text{C}$ , LMP8601EDRQ1 only	97		103	k $\Omega$
TCR <sub>F-INT</sub>	Preamplifier output impedance resistor drift	$T_A = -40^\circ\text{C}$ to $+125^\circ\text{C}$ $T_A = -40^\circ\text{C}$ to $+150^\circ\text{C}$ , LMP8601EDRQ1		$\pm 5$	$\pm 50$	ppm/ $^\circ\text{C}$
A1 V <sub>OUT</sub>	Swing to ground, $R_L = \text{No Load}$			2		mV
		$T_A = -40^\circ\text{C}$ to $+125^\circ\text{C}$ $T_A = -40^\circ\text{C}$ to $+150^\circ\text{C}$ , LMP8601EDRQ1			10	
A1 V <sub>OUT</sub>	A1 Swing to $V_S$ (Power supply rail), $R_L = \text{No Load}$			4.985		V
		$T_A = -40^\circ\text{C}$ to $+125^\circ\text{C}$ $T_A = -40^\circ\text{C}$ to $+150^\circ\text{C}$ , LMP8601EDRQ1	4.95			
<b>OUTPUT BUFFER</b>						
V <sub>os_B</sub>	Buffer Stage input offset voltage, input referred	$0\text{V} \leq V_{\text{CM}} \leq V_S$		$\pm 0.5$	$\pm 2$	mV
		$0\text{V} \leq V_{\text{CM}} \leq V_S$ , $T_A = -40^\circ\text{C}$ to $+125^\circ\text{C}$ $T_A = -40^\circ\text{C}$ to $+150^\circ\text{C}$ , LMP8601EDRQ1			$\pm 2.5$	
K2	Output buffer gain	LMP8601-Q1	1.99	2	2.01	V/V
		LMP8602-Q1	4.975	5	5.025	
		LMP8603-Q1	9.95	10.0	10.05	
I <sub>B_B</sub>	Input bias current of A2			$\pm 2$		pA
		$T_A = -40^\circ\text{C}$ to $+125^\circ\text{C}$ $T_A = -40^\circ\text{C}$ to $+150^\circ\text{C}$ , LMP8601EDRQ1			$\pm 20$	nA

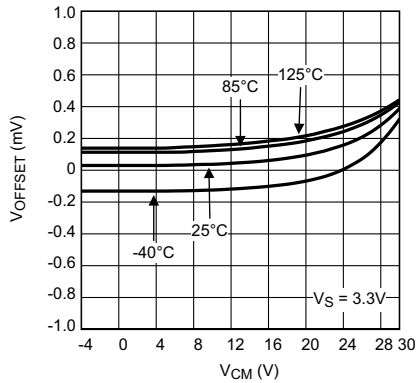
at  $T_A = 25\text{ }^\circ\text{C}$ ,  $V_S = 5\text{V}$ ,  $\text{GND} = 0\text{V}$ ,  $V_{\text{CM}} = V_S/2$ ,  $\text{OFFSET} = \text{GND}$ ,  $R_L = \text{No Load}$  (unless otherwise noted)

PARAMETER		TEST CONDITIONS	MIN	TYP	MAX	UNIT
A2 $V_{\text{OUT}}$	Swing to ground, $R_L = 100\text{k}\Omega$ to $V_S$	LMP8601-Q1		4		mV
		LMP8601-Q1, $T_A = -40\text{ }^\circ\text{C}$ to $+125\text{ }^\circ\text{C}$ $T_A = -40\text{ }^\circ\text{C}$ to $+150\text{ }^\circ\text{C}$ , LMP8601EDRQ1			20	
		LMP8602-Q1		10		
		LMP8602-Q1, $T_A = -40\text{ }^\circ\text{C}$ to $+125\text{ }^\circ\text{C}$ $T_A = -40\text{ }^\circ\text{C}$ to $+150\text{ }^\circ\text{C}$ , LMP8601EDRQ1			40	
		LMP8603-Q1		10		
		LMP8603-Q1, $T_A = -40\text{ }^\circ\text{C}$ to $+125\text{ }^\circ\text{C}$ $T_A = -40\text{ }^\circ\text{C}$ to $+150\text{ }^\circ\text{C}$ , LMP8601EDRQ1			80	
	Swing to $V_S$ (Power supply rail), $R_L = 100\text{k}\Omega$ to ground			4.99		V
		$T_A = -40\text{ }^\circ\text{C}$ to $+125\text{ }^\circ\text{C}$ $T_A = -40\text{ }^\circ\text{C}$ to $+150\text{ }^\circ\text{C}$ , LMP8601EDRQ1	4.98			
$I_{\text{SC}}$	Output short-circuit current	Sourcing, $V_{\text{IN}} = V_S$ , $V_{\text{OUT}} = \text{GND}$	-60	-42	-25	mA
		Sinking, $V_{\text{IN}} = \text{GND}$ , $V_{\text{OUT}} = V_S$	30	48	65	

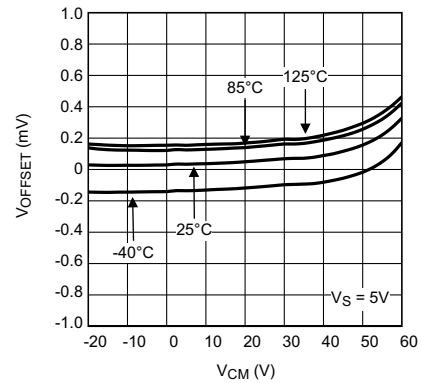
 (1) Common-mode voltage at both  $V_{\text{IN}+}$  and  $V_{\text{IN}-}$  must not exceed the specified common-mode input range.

### 5.7 Typical Characteristics

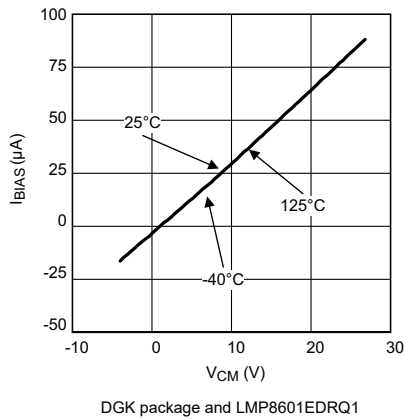
at  $T_A = 25^\circ\text{C}$ ,  $V_S = 5\text{V}$ ,  $\text{GND} = 0\text{V}$ ,  $V_{\text{CM}} = V_S/2$ ,  $\text{OFFSET} = V_S$ ,  $R_L = \text{No Load}$  (unless otherwise noted)



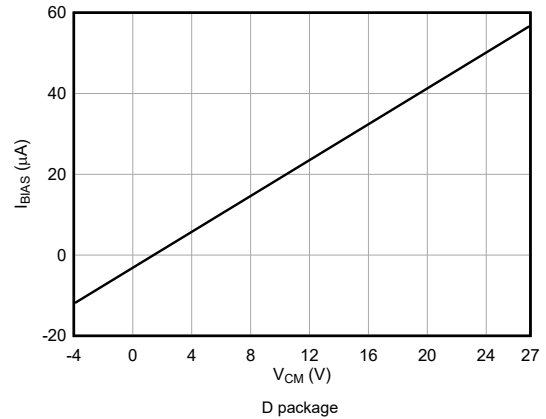
**Figure 5-1.  $V_{\text{OS}}$  vs  $V_{\text{CM}}$  at  $V_S = 3.3\text{V}$**



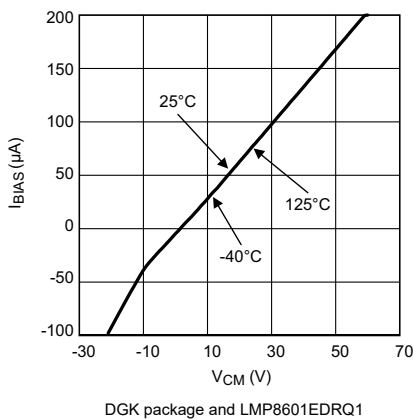
**Figure 5-2.  $V_{\text{OS}}$  vs  $V_{\text{CM}}$  at  $V_S = 5\text{V}$**



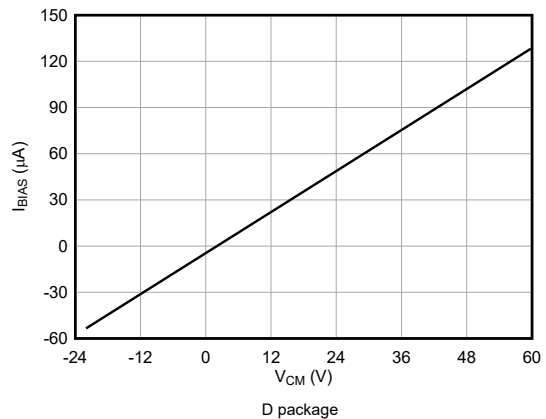
**Figure 5-3. Input Bias Current Over Temperature (+IN and -IN pins) at  $V_S = 3.3\text{V}$**



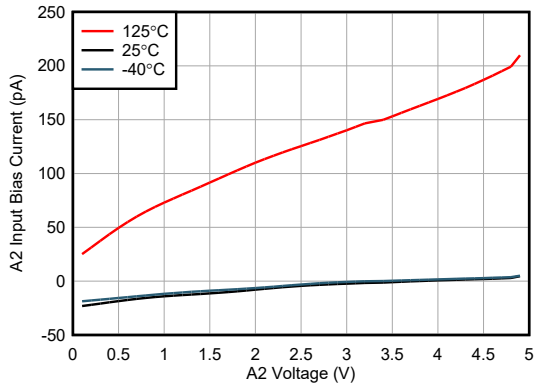
**Figure 5-4. Input Bias Current Over Temperature (+IN and -IN pins) at  $V_S = 3.3\text{V}$**



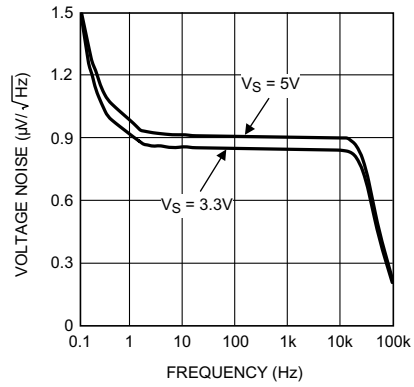
**Figure 5-5. Input Bias Current Over Temperature (+IN and -IN pins) at  $V_S = 5\text{V}$**



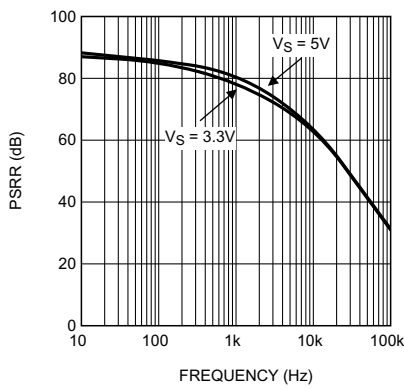
**Figure 5-6. Input Bias Current Over Temperature (+IN and -IN pins) at  $V_S = 5\text{V}$**



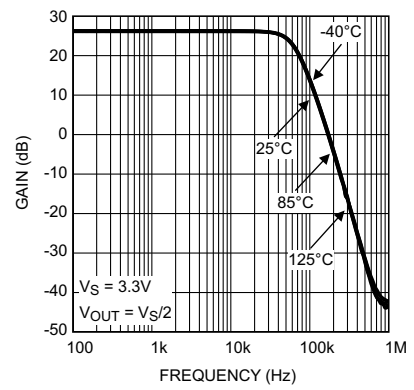
**Figure 5-7. Input Bias Current Over Temperature (A2 pin) at  $V_S = 5V$**



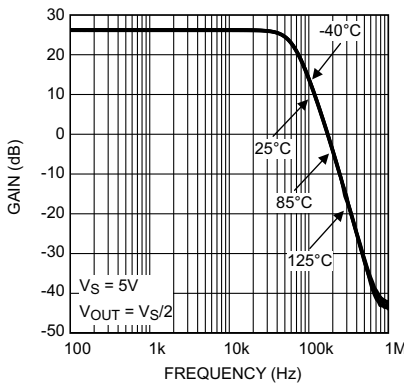
**Figure 5-8. Input-Referred Voltage Noise vs Frequency**



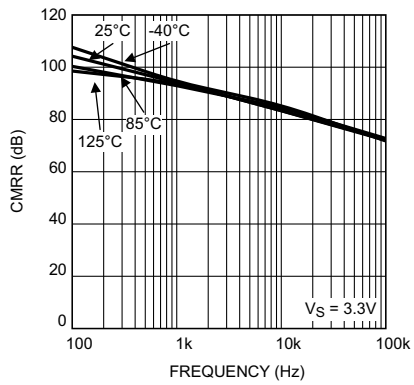
**Figure 5-9. PSRR vs Frequency**



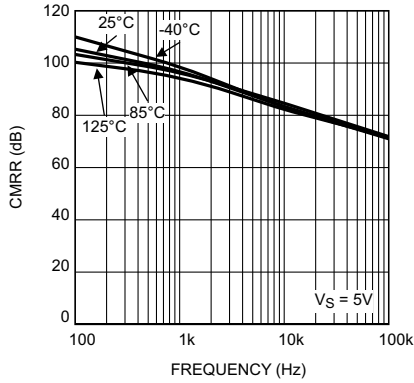
**Figure 5-10. Gain vs Frequency at  $V_S = 3.3V$**



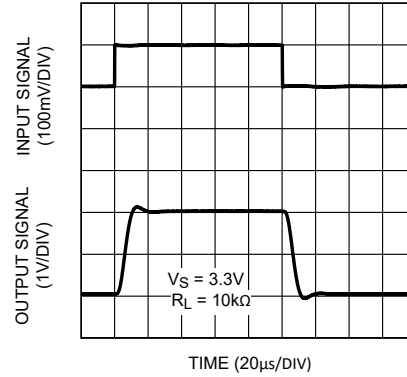
**Figure 5-11. Gain vs Frequency at  $V_S = 5V$**



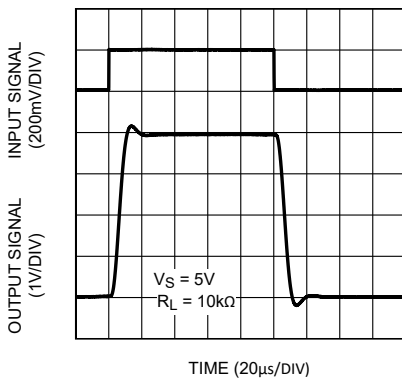
**Figure 5-12. CMRR vs Frequency at  $V_S = 3.3V$**



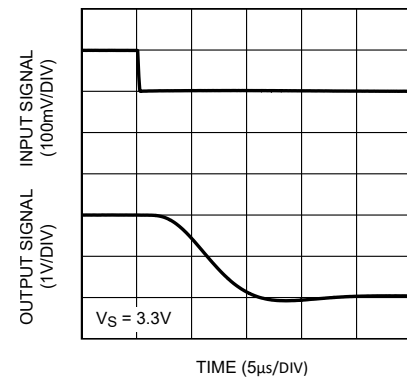
**Figure 5-13. CMRR vs Frequency at  $V_S = 5V$**



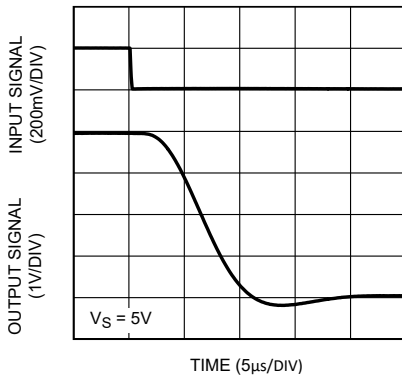
**Figure 5-14. Step Response at  $V_S = 3.3V$  LMP8601-Q1**



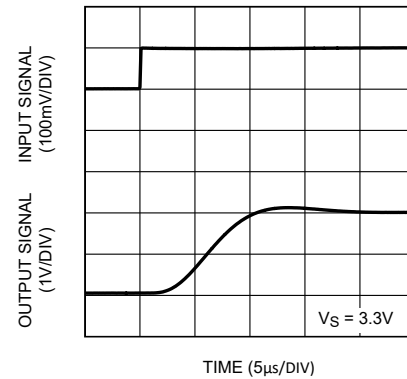
**Figure 5-15. Step Response at  $V_S = 5V$  LMP8601-Q1**



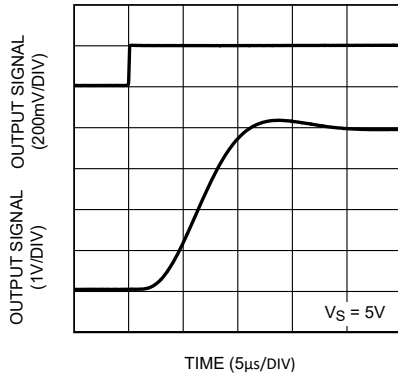
**Figure 5-16. Settling Time (Falling Edge) at  $V_S = 3.3V$  LMP8601-Q1**



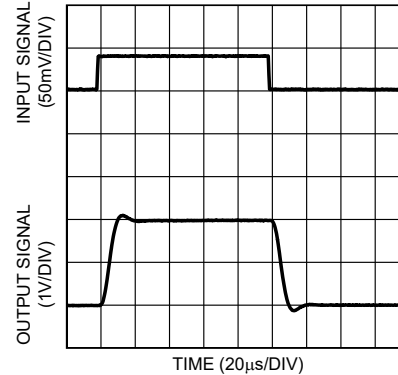
**Figure 5-17. Settling Time (Falling Edge) at  $V_S = 5V$  LMP8601-Q1**



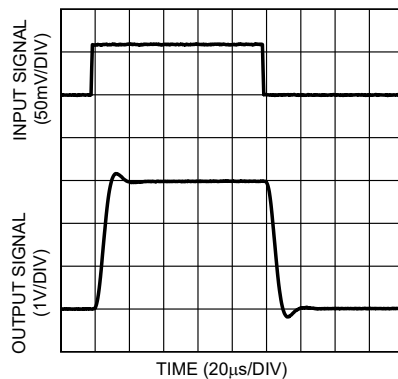
**Figure 5-18. Settling Time (Rising Edge) at  $V_S = 3.3V$  LMP8601-Q1**



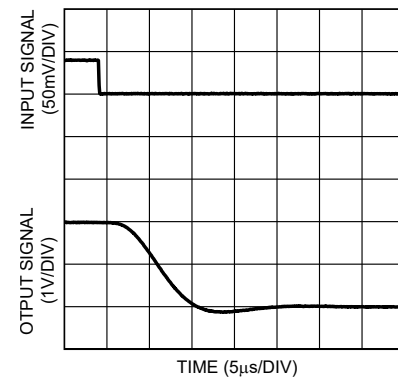
**Figure 5-19. Settling Time (Rising Edge) at  $V_S = 5V$   
LMP8601-Q1**



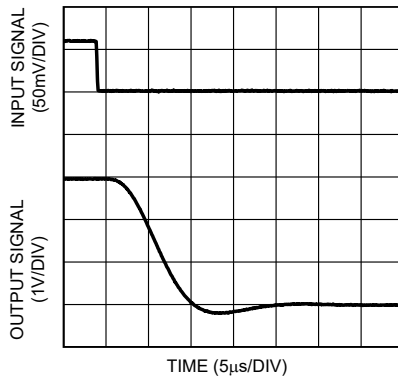
**Figure 5-20. Step Response at  $V_S = 3.3V$ ,  $R_L = 10k\Omega$   
LMP8602-Q1**



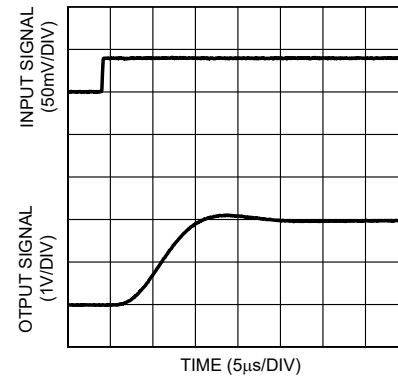
**Figure 5-21. Step Response at  $V_S = 5V$ ,  $R_L = 10k\Omega$   
LMP8602-Q1**



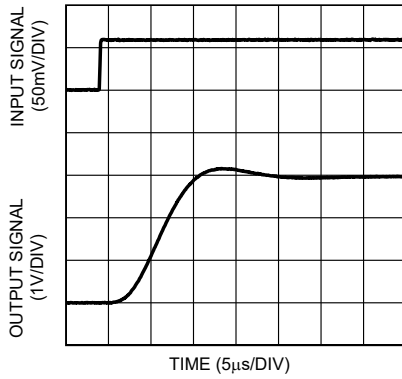
**Figure 5-22. Settling Time (Falling Edge) at  $V_S = 3.3V$   
LMP8602-Q1**



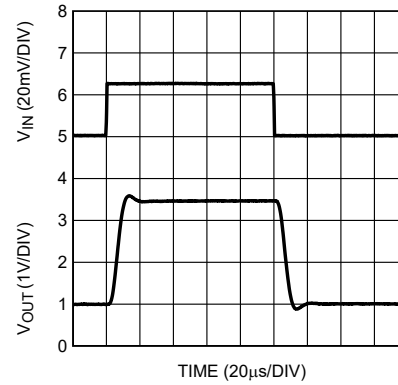
**Figure 5-23. Settling Time (Falling Edge) at  $V_S = 5V$   
LMP8602-Q1**



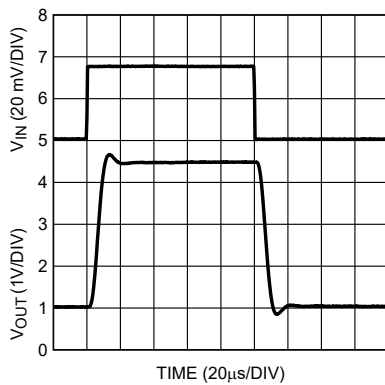
**Figure 5-24. Settling Time (Rising Edge) at  $V_S = 3.3V$   
LMP8602-Q1**



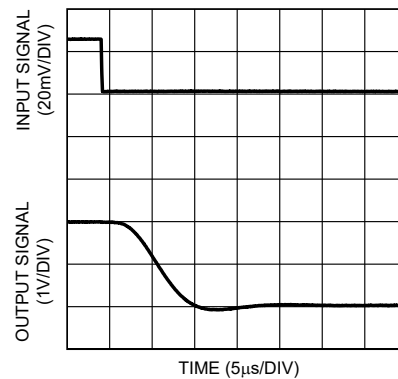
**Figure 5-25. Settling Time (Rising Edge) at  $V_S = 5V$  LMP8602-Q1**



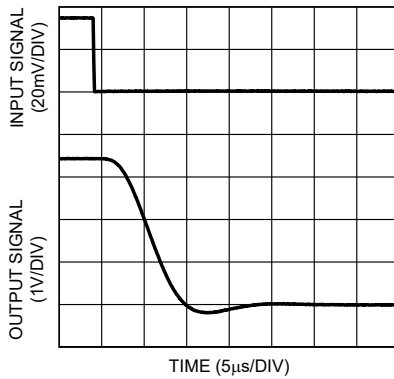
**Figure 5-26. Step Response at  $V_S = 3.3V$ ,  $R_L = 10k\Omega$  LMP8603-Q1**



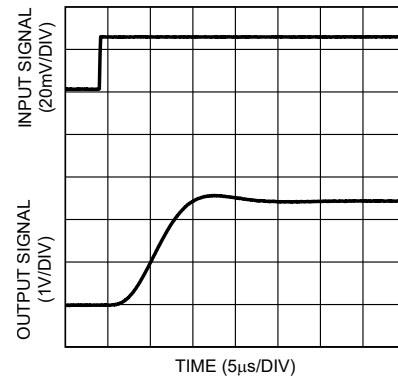
**Figure 5-27. Step Response at  $V_S = 5V$ ,  $R_L = 10k\Omega$  LMP8603-Q1**



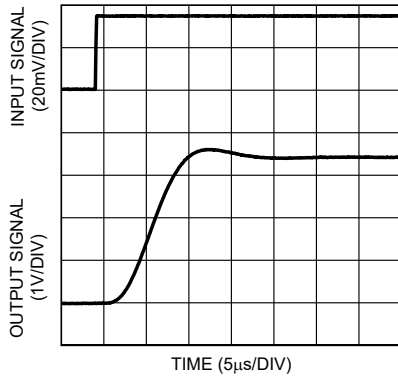
**Figure 5-28. Settling Time (Falling Edge) at  $V_S = 3.3V$  LMP8603-Q1**



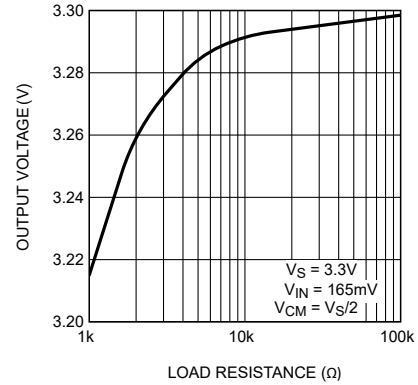
**Figure 5-29. Settling Time (Falling Edge) at  $V_S = 5V$  LMP8603-Q1**



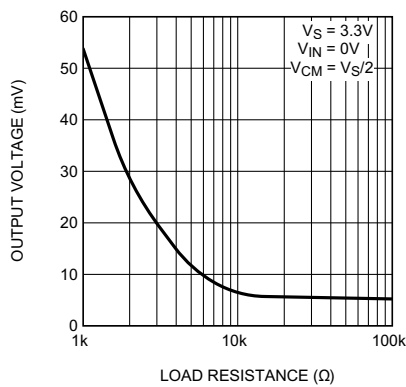
**Figure 5-30. Settling Time (Rising Edge) at  $V_S = 3.3V$  LMP8603-Q1**



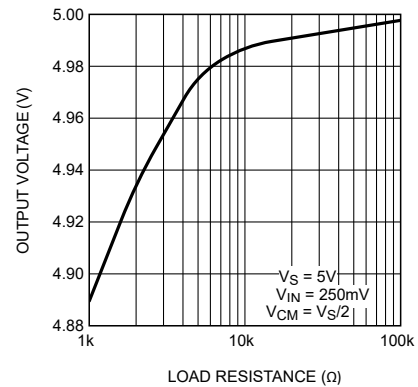
**Figure 5-31. Settling Time (Rising Edge) at  $V_S = 5V$  LMP8603-Q1**



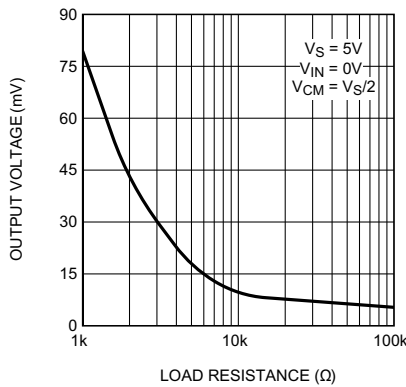
**Figure 5-32. Positive Swing vs  $R_{LOAD}$  at  $V_S = 3.3V$**



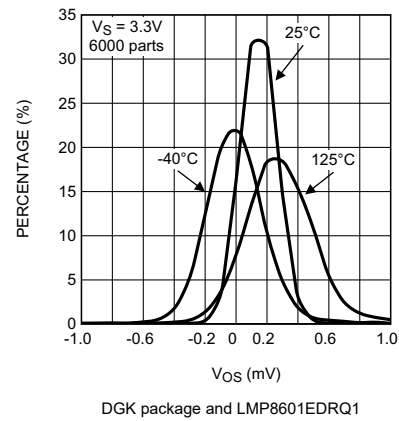
**Figure 5-33. Negative Swing vs  $R_{LOAD}$  at  $V_S = 3.3V$**



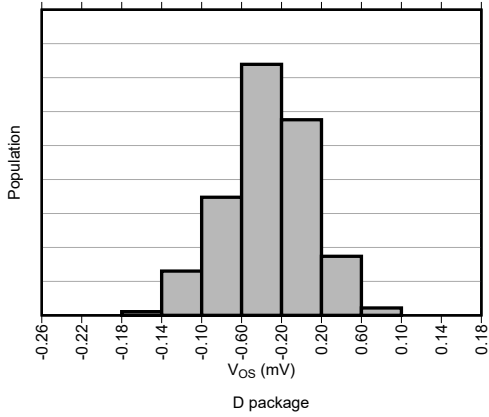
**Figure 5-34. Positive Swing vs  $R_{LOAD}$   $V_S = 5V$**



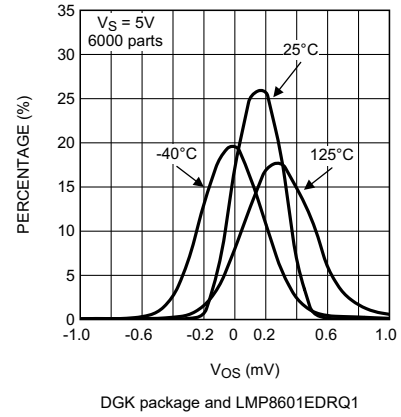
**Figure 5-35. Negative Swing vs  $R_{LOAD}$  at  $V_S = 5V$**



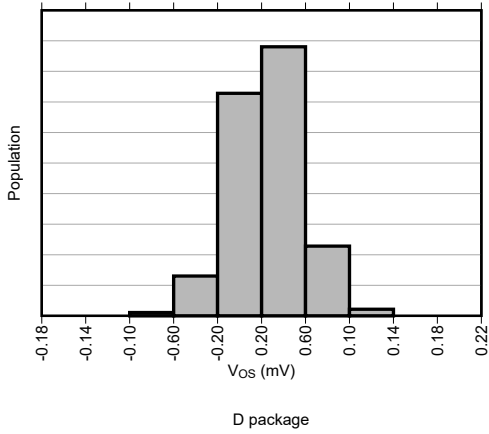
**Figure 5-36.  $V_{OS}$  Distribution at  $V_S = 3.3V$**



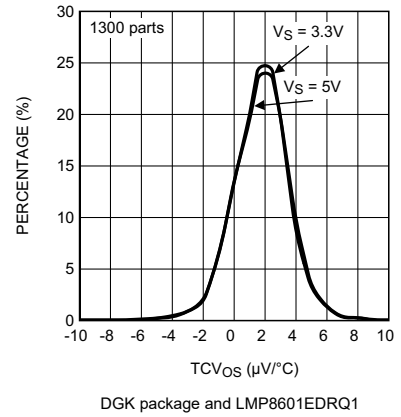
**Figure 5-37. Vos Distribution at Vs = 3.3V**



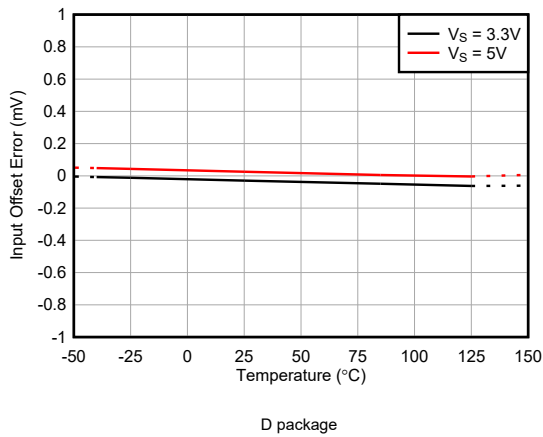
**Figure 5-38. Vos Distribution at Vs = 5V**



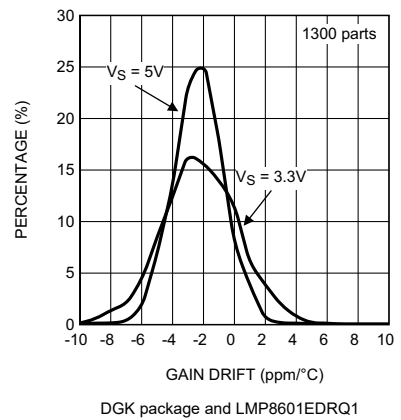
**Figure 5-39. Vos Distribution at Vs = 5V**



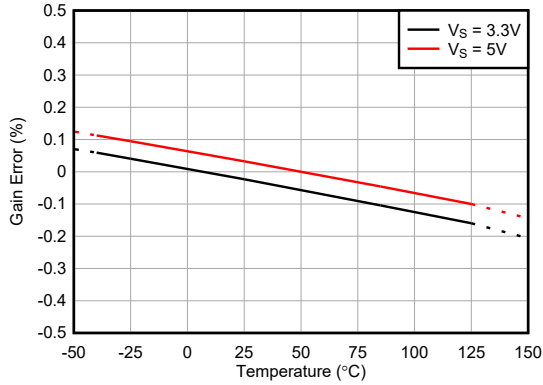
**Figure 5-40. TCVos Distribution**



**Figure 5-41. Vos Vs Temperature**

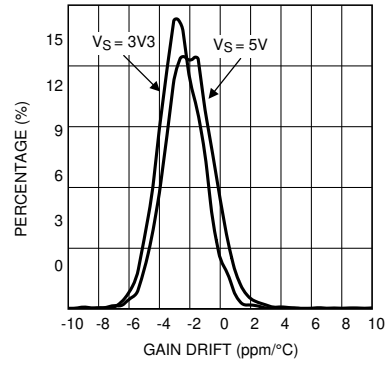


**Figure 5-42. Gain Drift Distribution, 1300 Parts LMP8601-Q1**



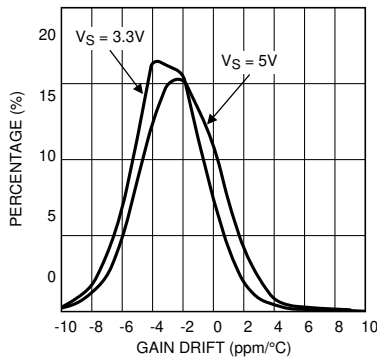
D package

**Figure 5-43. Gain Error vs Temperature for All Gains**



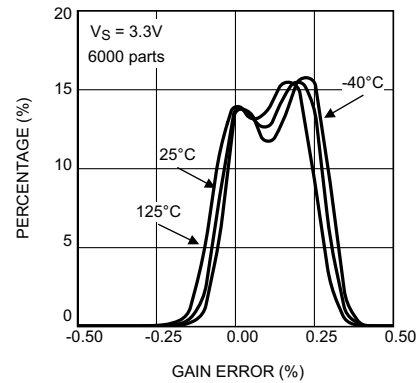
DGK package

**Figure 5-44. Gain Drift Distribution, 5000 Parts LMP8602-Q1**



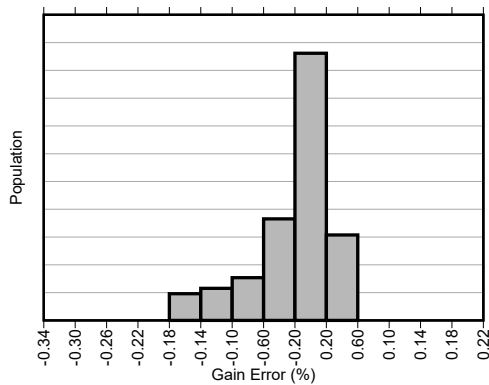
DGK package

**Figure 5-45. Gain Drift Distribution, 5000 Parts LMP8603-Q1**



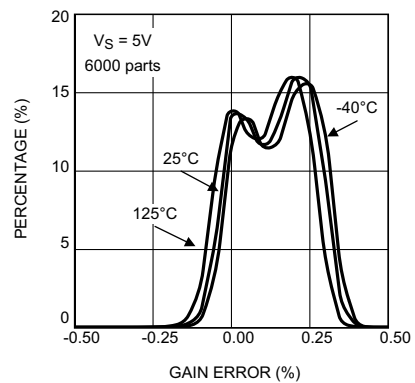
DGK package and LMP8601EDRQ1

**Figure 5-46. Gain Error Distribution at  $V_S = 3.3V$  LMP8601-Q1**



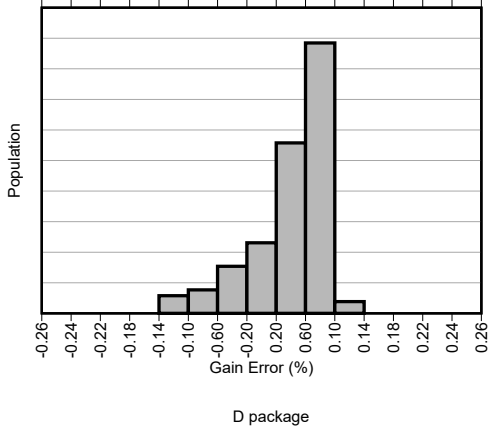
D package

**Figure 5-47. Gain Error Distribution at  $V_S = 3.3V$  LMP8601-Q1**

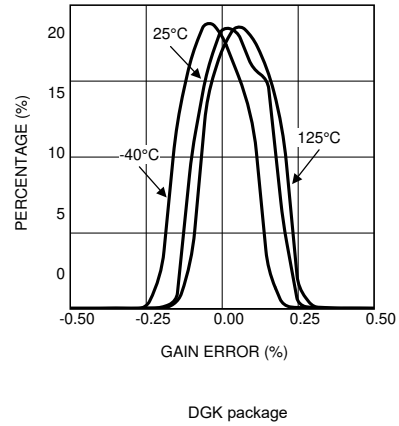


DGK package and LMP8601EDRQ1

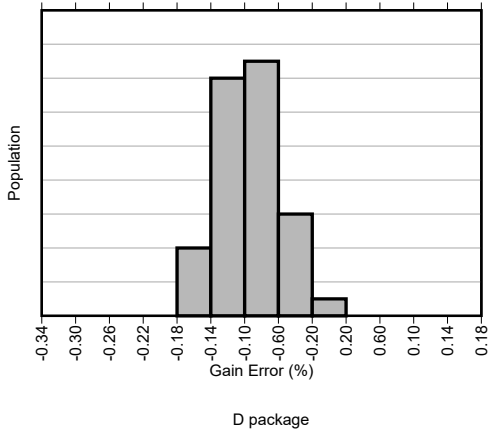
**Figure 5-48. Gain Error Distribution at  $V_S = 5V$  LMP8601-Q1**



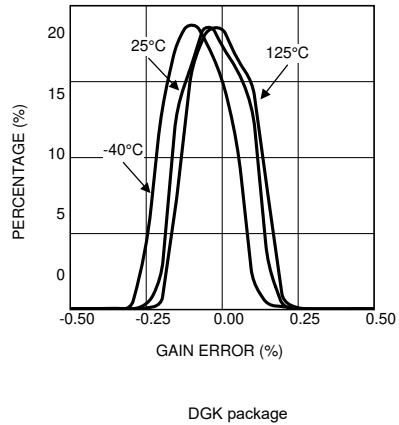
**Figure 5-49. Gain Error Distribution at  $V_S = 5V$  LMP8601-Q1**



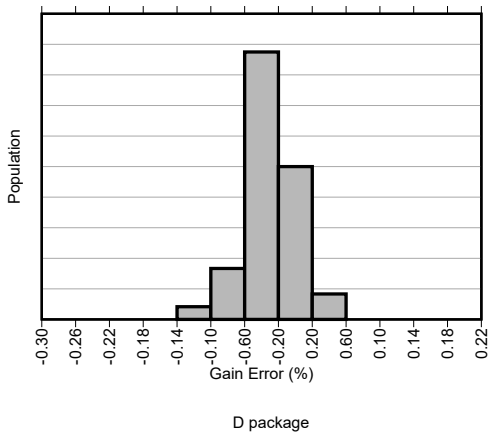
**Figure 5-50. Gain Error Distribution at  $V_S = 3.3V$ , 5000 Parts LMP8602-Q1**



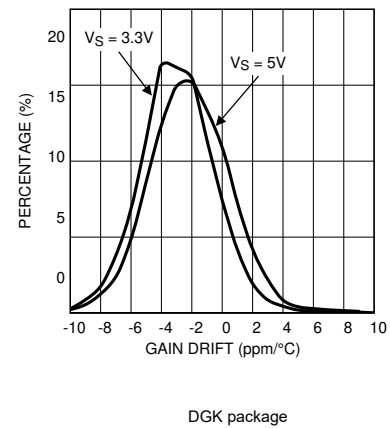
**Figure 5-51. Gain Error Distribution at  $V_S = 3.3V$  LMP8602-Q1**



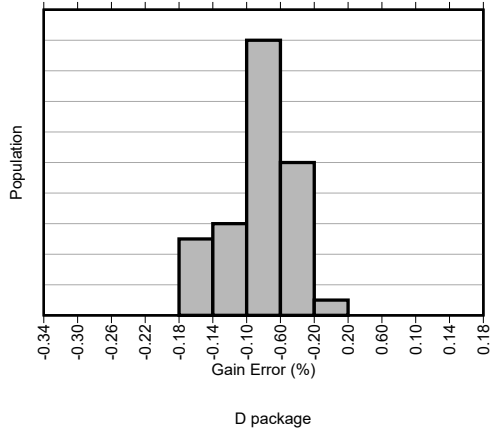
**Figure 5-52. Gain Error Distribution at  $V_S = 5V$ , 5000 Parts LMP8602-Q1**



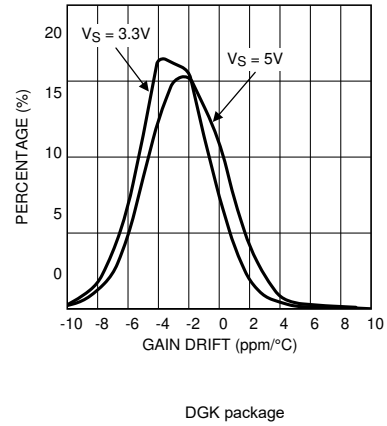
**Figure 5-53. Gain Error Distribution at  $V_S = 5V$  LMP8602-Q1**



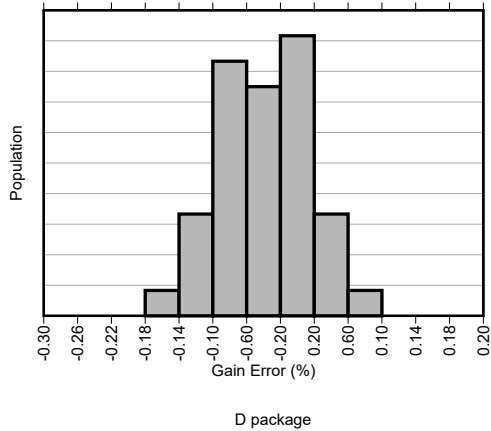
**Figure 5-54. Gain Error Distribution at  $V_S = 3.3V$ , 5000 Parts LMP8603-Q1**



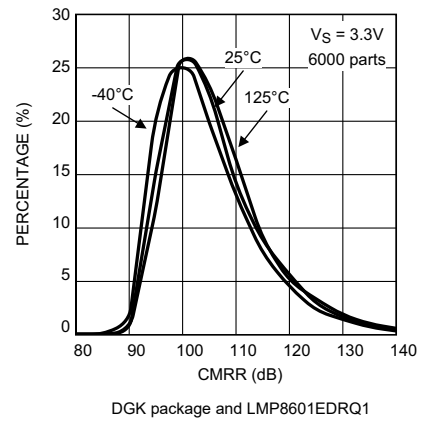
**Figure 5-55. Gain Error Distribution at  $V_S = 3.3V$   
LMP8603-Q1**



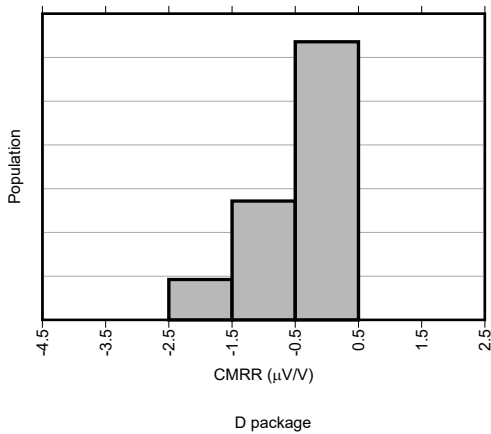
**Figure 5-56. Gain Error Distribution at  $V_S = 5V$   
LMP8603-Q1**



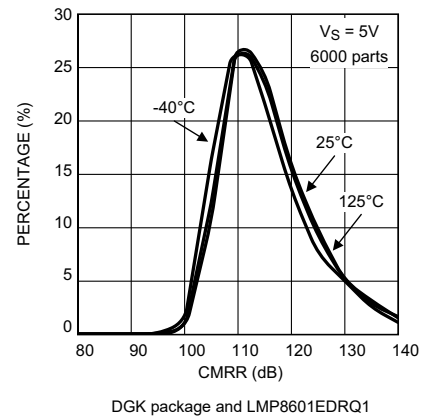
**Figure 5-57. Gain Error Distribution at  $V_S = 5V$   
LMP8603-Q1**



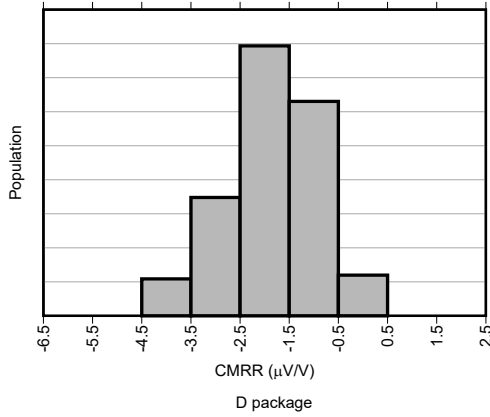
**Figure 5-58. CMRR Distribution at  $V_S = 3.3V$**



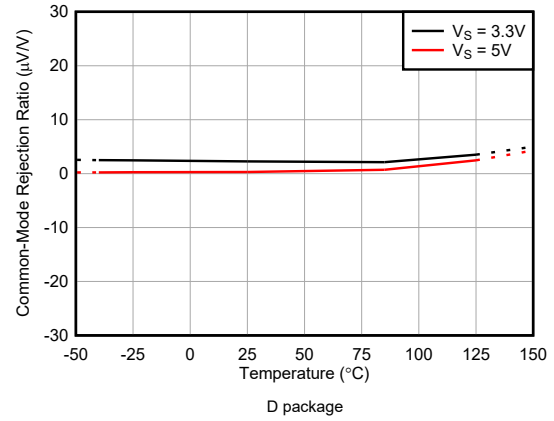
**Figure 5-59. CMRR Distribution at  $V_S = 3.3V$**



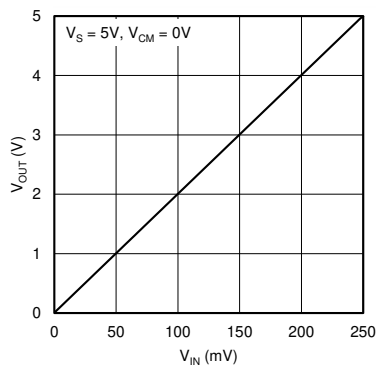
**Figure 5-60. CMRR Distribution at  $V_S = 5V$**



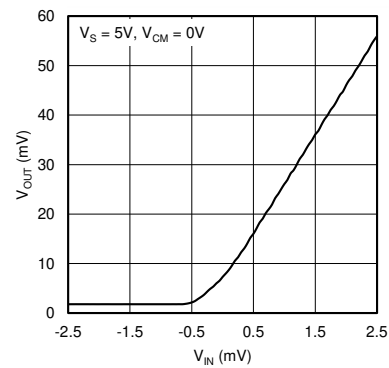
**Figure 5-61. CMRR Distribution at  $V_S = 5V$**



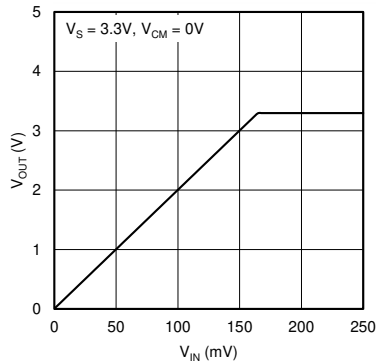
**Figure 5-62. CMRR vs Temperature**



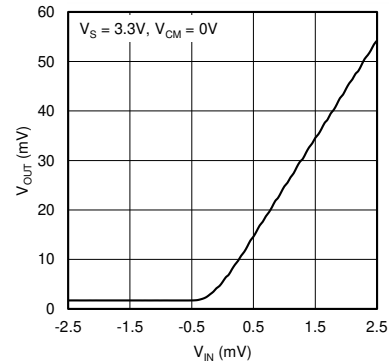
**Figure 5-63. Output Voltage vs  $V_{IN}$**



**Figure 5-64. Output Voltage vs  $V_{IN}$  (Enlarged Close to 0V)**



**Figure 5-65. Output Voltage vs  $V_{IN}$**



**Figure 5-66. Output Voltage vs  $V_{IN}$  (Enlarged Close to 0V)**

## 6 Detailed Description

### 6.1 Overview

The LMP860x-Q1 are fixed gain differential voltage precision amplifiers, with a  $-22\text{V}$  to  $+60\text{V}$  input common-mode voltage range when operating from a single  $5\text{V}$  supply, or a  $-4\text{V}$  to  $+27\text{V}$  input common-mode voltage range when operating from a single  $3.3\text{V}$  supply. The LMP8601-Q1 has a gain of  $20\times$ , the LMP8602-Q1 has a gain of  $50\times$ , and the LMP8603-Q1 has a gain of  $100\times$ .

The LMP860x-Q1 is a member of the LMP family and is designed for unidirectional and bidirectional current sensing applications. Because of the proprietary chopping level-shift input stage, the LMP860x-Q1 device achieves very low offset, very low thermal offset drift, and very high CMRR. The LMP860x-Q1 amplify and filter small differential signals in the presence of high common-mode voltages.

The LMP860x-Q1 device uses level shift resistors at the inputs. Because of these resistors, the LMP860x-Q1 device can easily withstand very large differential input voltages that can exist in fault conditions where some other less protected high-performance current sense amplifiers can sustain permanent damage.

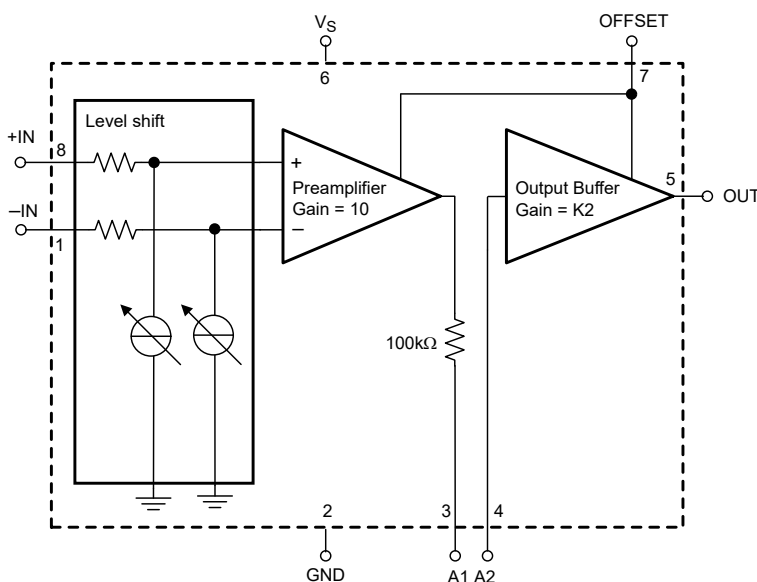
#### 6.1.1 Theory of Operation

The schematic shown in the [Section 6.2](#) gives a basic representation of the internal operation of the LMP860x-Q1.

The signal on the input pins is typically a small differential voltage developed across a current sensing shunt resistor. The input signal can also appear at a high common-mode voltage. The input signals are accessed through two input resistors that change the voltage into a current. The proprietary chopping level-shift current circuit pulls or pushes current through the input resistors to bring the common-mode voltage behind these resistors within the supply rails.

Subsequently, the signal is gained up by a factor of 10 and brought out on the A1 pin through a trimmed  $100\text{k}\Omega$  resistor. In the application, additional gain adjustment or filtering components can be added between the A1 and A2 pins as explained in subsequent sections. The signal on the A2 pin is further amplified by a factor of 2 (LMP8601-Q1), 5 (LMP8602-Q1), or 10 (LMP8603-Q1), and brought out on the OUT pin.

### 6.2 Functional Block Diagram



NOTE:  $K2 = 2$  for LMP8601-Q1;  $5$  for LMP8602-Q1; or  $10$  for LMP8603-Q1.

## 6.3 Feature Description

### 6.3.1 Offset Input Pin

The OFFSET pin allows the output signal to be level-shifted to enable bidirectional current sensing. The output signal is bidirectional and mid-rail referenced when the offset pin is connected to the positive supply rail. With the offset pin connected to ground, the output signal is unidirectional and ground-referenced.

The signal on the A1 and OUT pins is ground-referenced when the offset pin is connected to ground. This means that the output signal can only represent positive values of the current through the shunt resistor, so only currents flowing in one direction can be measured.

When the offset pin is tied to the positive supply rail, the signal on the A1 and OUT pins is referenced to a mid-rail voltage which allows bidirectional current sensing. The operation of the amplifier is fully bidirectional and symmetrical around 0V differential at the input pins. The signal at the output follows this voltage difference multiplied by the gain and at an offset voltage at the output of half  $V_S$ .

When the offset pin is connected to an external voltage source, the output signal is level shifted to that voltage divided by two. In principle, the output signal can be shifted to any voltage between 0 and  $V_S / 2$  by applying twice that voltage to the OFFSET pin. The OFFSET pin must be driven from a very low-impedance source ( $< 10\Omega$ ). This low source impedance is required because the OFFSET pin internally connects directly to the resistive feedback networks of the two gain stages. When the OFFSET pin is driven from a relatively large impedance (for example, a resistive divider between the supply rails), accuracy decreases.

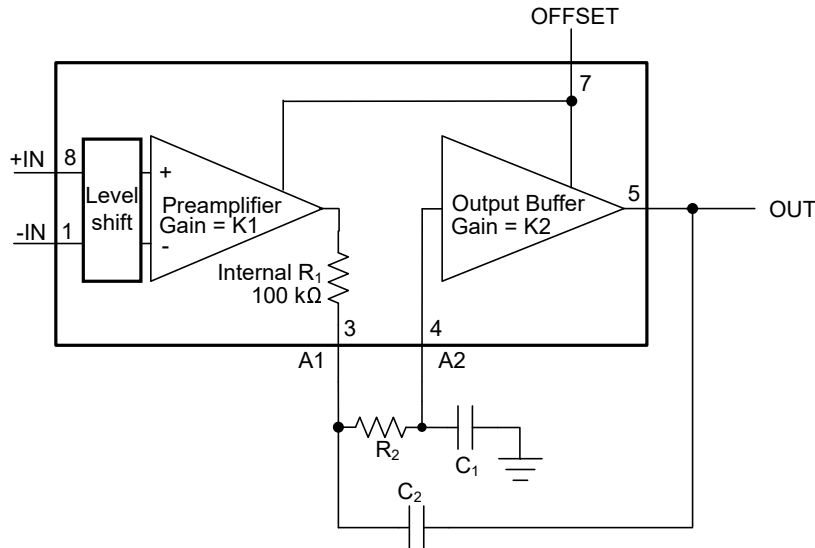
Examples:

- **LMP8601-Q1** : A 5V supply, a gain of 20x, OFFSET pin tied to  $V_S$ , and a differential input signal of 10mV results in 2.7V at the output pin. Similarly,  $-10\text{mV}$  at the input results in 2.3V at the output pin.
- **LMP8602-Q1** : A 5V supply, a gain of 50x, and a differential input signal of 10mV results in 3.0V at the output pin. Similarly,  $-10\text{mV}$  at the input results in 2.0V at the output pin.
- **LMP8603-Q1** : A 5V supply, a gain of 100x, and a differential input signal of 10mV results in 3.5V at the output pin. Similarly,  $-10\text{mV}$  at the input results in 1.5V at the output pin.

### 6.3.2 Additional Second-Order Low-Pass Filter

The LMP86x1-Q1 have a third-order Butterworth lowpass characteristic with a typical bandwidth of 60kHz integrated in the preamplifier stage. The bandwidth of the output buffer can be reduced by adding a capacitor on the A1 pin to create a first-order low-pass filter with a time constant determined by the 100kΩ internal resistor and the external filter capacitor.

Creating an additional second-order is also possible, Sallen-Key, low-pass filter by adding external components  $R_2$ ,  $C_1$  and  $C_2$ . Together with the internal 100kΩ resistor  $R_1$  as illustrated in Figure 6-1, this circuit creates a second-order, low-pass filter characteristic.



NOTE:  $K_1 = 10$ ;  $K_2 = 2$  for LMP8601-Q1; 5 for LMP8602-Q1; or 10 for LMP8603-Q1.

**Figure 6-1. Second-Order Low-Pass Filter**

When the corner frequency of the additional filter is much lower than 60kHz, the transfer function of the described amplifier can be written as:

$$H(s) = \frac{K_1 \times K_2 \frac{1}{R_1 R_2 C_1 C_2}}{s^2 + s \times \left[ \frac{1}{R_1 C_2} + \frac{1}{R_2 C_2} + \frac{1-K_2}{R_2 C_1} \right] + \frac{1}{R_1 R_2 C_1 C_2}} \quad (1)$$

where

- $K_1$  equals the gain of the preamplifier and  $K_2$  that of the buffer amplifier.

Equation 1 can be written in the normalized frequency response for a second-order lowpass filter:

$$G(j\omega) = K_1 \times \frac{K_2}{\frac{(j\omega)^2}{\omega_0^2} + \frac{j\omega}{Q\omega_0} + 1} \quad (2)$$

The cutoff frequency  $\omega_0$  in rad/sec (divide by  $2\pi$  to get the cut-off frequency in Hz) is given by:

$$\omega_0 = \frac{1}{\sqrt{R_1 R_2 C_1 C_2}} \quad (3)$$

and the quality factor of the filter is given by:

$$Q = \frac{\sqrt{R_1 R_2 C_1 C_2}}{R_1 C_1 + R_2 C_1 + (1 - K_2) \times R_1 C_2} \quad (4)$$

With  $K_2 = 2x$ , Equation 4 transforms results in:

$$Q = \frac{\sqrt{R_1 R_2 C_1 C_2}}{R_1 C_1 + R_2 C_1 - R_1 C_2} \quad (5)$$

For any filter gain  $K > 1x$ , the design procedure can be very simple if the two capacitors are chosen to in a certain ratio.

$$C_2 = \frac{C_1}{K_2 - 1} \quad (6)$$

Inserting this in Equation 4 for Q results in:

$$Q = \frac{\sqrt{R_1 R_2 \frac{C_1^2}{K_2 - 1}}}{R_1 C_1 + R_2 C_1 - \frac{(K_2 - 1) R_1 C_1}{K_2 - 1}} \quad (7)$$

Which results in:

$$Q = \frac{\sqrt{R_1 R_2 \frac{C_1^2}{K_2 - 1}}}{C_1 R_2} = \frac{\sqrt{R_1 R_2}}{R_2} \quad (8)$$

In this case, given the predetermined value of  $R_1 = 100k\Omega$  (the internal resistor), the quality factor is set solely by the value of the resistor  $R_2$ .

$R_2$  can be calculated based on the desired value of Q as the first step of the design procedure with the following equation:

$$R_2 = \frac{R_1}{(K - 1)Q^2} \quad (9)$$

For the gain of 2 for the LMP8601-Q1, the result is:

$$R_2 = \frac{R_1}{Q^2} \quad (10)$$

For the gain of 5 for the LMP8602-Q1, the result is:

$$R_2 = \frac{R_1}{4Q^2} \quad (11)$$

For the gain of 10 for the LMP8603-Q1, the result is:

$$R_2 = \frac{R_1}{9Q^2} \quad (12)$$

For instance, the value of Q can be set to  $0.5\sqrt{2}$  to create a Butterworth response, to  $1/\sqrt{3}$  to create a Bessel response, or a 0.5 to create a critically damped response. After the value of  $R_2$  has been found, the second and last step of the design procedure is to calculate the required value of C to give the desired low-pass cut-off frequency using:

$$C_1 = \frac{(K-1)Q}{R_1\omega_0} \quad (13)$$

For the gain = 2, the result is:

$$C = \frac{Q}{R_1\omega_0} \quad (14)$$

The gain = 5 results in:

$$C_1 = \frac{4Q}{R_1\omega_0} \quad (15)$$

The gain = 10 gives:

$$C_1 = \frac{9Q}{R_1\omega_0} \quad (16)$$

For  $C_2$  the value is calculated with:

$$C_2 = \frac{C_1}{K_2 - 1} \quad (17)$$

For a gain = 2:

$$C_2 = C_1 \quad (18)$$

Or for a gain = 5:

$$C_2 = \frac{C_1}{4} \quad (19)$$

And for a gain = 10:

$$C_2 = \frac{C_1}{9} \quad (20)$$

Note that the frequency response achieved using this procedure is only accurate if the cut-off frequency of the second-order filter is much smaller than the intrinsic 60kHz, low-pass filter. In other words, select the frequency response of the LMP8601-Q1 circuit so that the internal poles do not affect the external second-order filter.

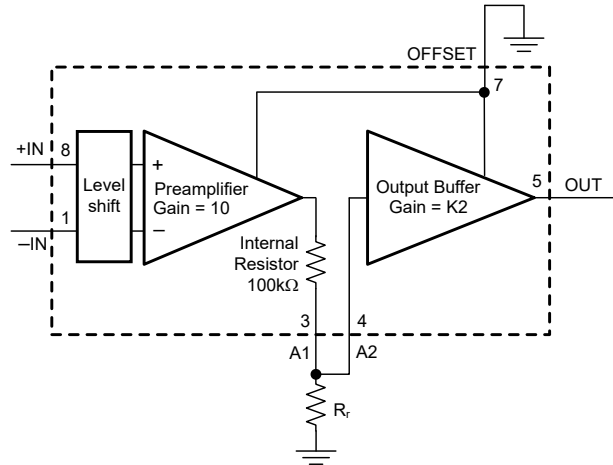
## 6.4 Device Functional Modes

### 6.4.1 Gain Adjustment

The gain of the LMP860x-Q1 is fixed; however, the overall gain can be adjusted as the signal path between the two internal amplifiers is available on the A1 and A2 pins.

#### 6.4.1.1 Reducing Gain

Figure 6-2 shows the configuration that can be used to reduce the gain of the LMP8601-Q1.



NOTE: K2 = 2 for LMP8601-Q1; 5 for LMP8602-Q1; or 10 for LMP8603-Q1.

**Figure 6-2. Reduce Gain**

$R_r$  creates a resistive divider together with the internal  $100\text{k}\Omega$  resistor such that the reduced gain  $G_r$  becomes:

$$G_t = \frac{20R_r}{R_r + 100\text{k}\Omega} \quad (21)$$

For the LMP8602-Q1:

$$G_t = \frac{50R_r}{R_r + 100\text{k}\Omega} \quad (22)$$

And for the LMP8603-Q1:

$$G_t = \frac{100R_r}{R_r + 100\text{k}\Omega} \quad (23)$$

Given a desired value of the reduced gain  $G_r$ , using this equation, the LMP8601-Q1 required value for the  $R_r$  is calculated with:

$$R_r = 100\text{k}\Omega \times \frac{G_r}{20 - G_r} \quad (24)$$

For the LMP8602-Q1:

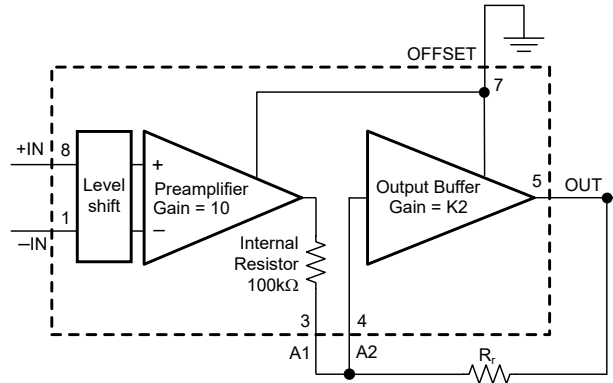
$$R_r = 100\text{k}\Omega \times \frac{G_r}{50 - G_r} \quad (25)$$

And for the LMP8603-Q1:

$$R_r = 100\text{k}\Omega \times \frac{G_r}{100 - G_r} \quad (26)$$

#### 6.4.1.2 Increasing Gain

Figure 6-3 shows the configuration that can be used to increase the gain of the LMP8601-Q1.



NOTE: K2 = 2 for LMP8601-Q1; 5 for LMP8602-Q1; or 10 for LMP8603-Q1.

**Figure 6-3. Increase Gain**

$R_f$  creates positive feedback from the output pin to the input of the buffer amplifier. The positive feedback increases the gain. The increased gain  $G_i$  for the LMP8601-Q1 becomes:

$$G_i = \frac{20R_i}{R_i + 100k\Omega} \quad (27)$$

For the LMP8602-Q1:

$$G_i = \frac{50R_i}{R_i + 400k\Omega} \quad (28)$$

And for the LMP8603-Q1:

$$G_i = \frac{100R_i}{R_i + 900k\Omega} \quad (29)$$

From this equation, for a desired value of the gain, the LMP8601-Q1 required value of  $R_i$  is calculated with:

$$R_i = 100k\Omega \times \frac{G_i}{G_i - 20} \quad (30)$$

For the LMP8602-Q1:

$$R_i = 400k\Omega \times \frac{G_i}{G_i - 50} \quad (31)$$

And for the LMP8603-Q1 with:

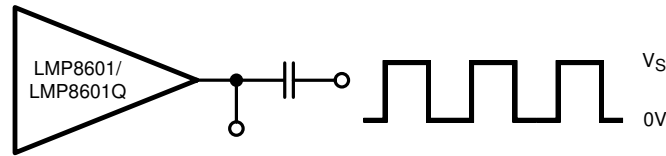
$$R_i = 900k\Omega \times \frac{G_i}{G_i - 100} \quad (32)$$

Note that from the equation for the gain  $G_i$ , for large gains,  $R_i$  approaches 100kΩ. In this case, the denominator in the equation becomes close to zero. In practice, for large gains, the denominator is determined by tolerances in the value of the external resistor  $R_f$  and the internal 100kΩ resistor. In this case, the gain becomes very inaccurate. If the denominator becomes equal to zero, the system becomes unstable. TI recommends to limit the application of this technique to gain values of 50 or smaller.

#### 6.4.2 Driving Switched Capacitive Loads

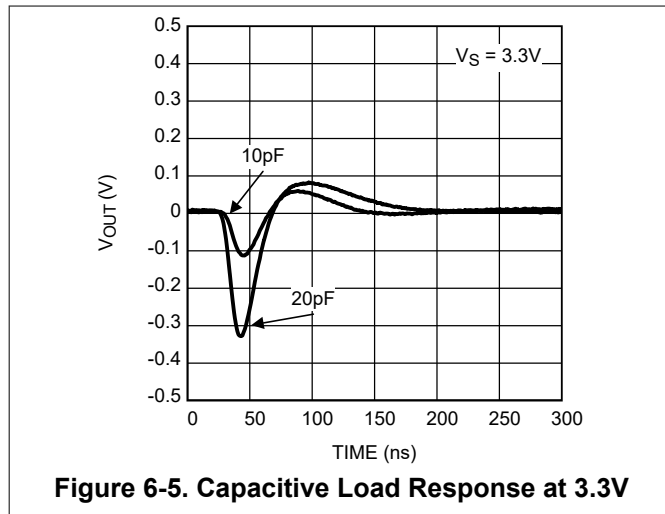
Some ADCs load the signal source with a sample and hold capacitor. The capacitor can be discharged prior to being connected to the signal source. If the LMP860x-Q1 are driving such ADCs, the sudden current that is

delivered when the sampling occurs can disturb the output signal. This effect is simulated with the circuit shown in [Figure 6-4](#) where the output is to a capacitor that is driven by a rail-to-rail square wave.

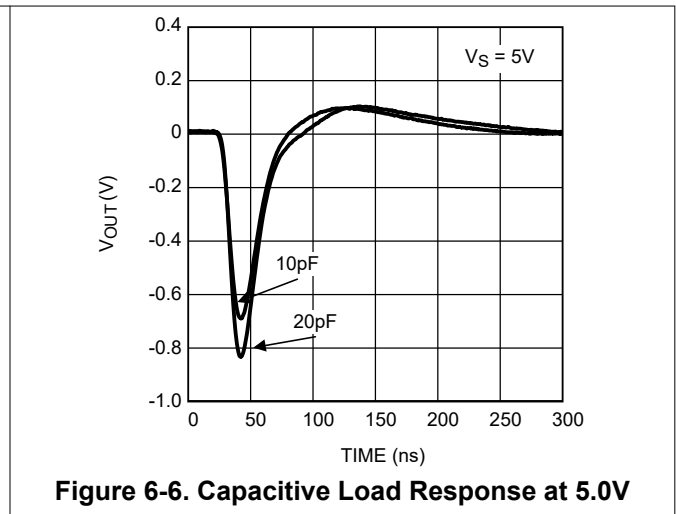


**Figure 6-4. Driving Switched Capacitive Load**

This circuit simulates the switched connection of a discharged capacitor to the LMP860x-Q1 output. The resulting  $V_{OUT}$  disturbance signals are shown in [Figure 6-5](#) and [Figure 6-6](#).

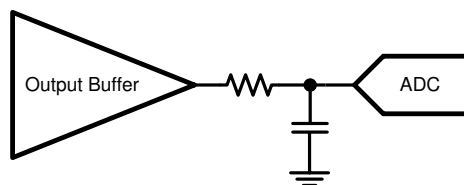


**Figure 6-5. Capacitive Load Response at 3.3V**



**Figure 6-6. Capacitive Load Response at 5.0V**

These figures can be used to estimate the disturbance that is caused when driving a switched capacitive load. To minimize the error signal introduced by the sampling that occurs on the ADC input, place an additional RC filter between the LMP860x-Q1 and the ADC, as illustrated in [Figure 6-7](#).



**Figure 6-7. Reduce Error When Driving ADCs**

The external capacitor absorbs the charge that flows when the ADC sampling capacitor is connected. The external capacitor must be much larger than the sample-and-hold capacitor at the input of the ADC, and the RC time constant of the external filter must be such that the speed of the system is not affected.

## 7 Application and Implementation

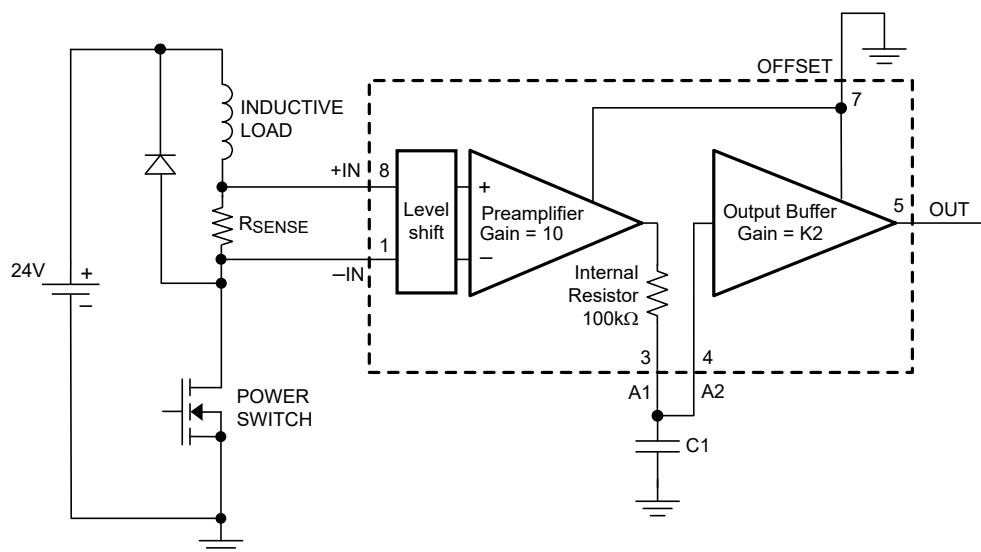
### Note

Information in the following applications sections is not part of the TI component specification, and TI does not warrant its accuracy or completeness. TI's customers are responsible for determining suitability of components for their purposes, as well as validating and testing their design implementation to confirm system functionality.

### 7.1 Typical Applications

#### 7.1.1 High-Side, Current-Sensing Application

Figure 7-1 illustrates the application of the LMP860x-Q1 in a high-side sensing application. This application is similar to the low-side sensing discussed below, except in this application the common-mode voltage on the shunt drops below ground when the driver is switched off. Because the common-mode voltage range of the LMP860x-Q1 extends below the negative rail, the LMP860x-Q1 are also designed for this application.



NOTE: For this application example,  $K2 = 2$ .

**Figure 7-1. High-Side, Current-Sensing Application**

### 7.1.1.1 Design Requirements

Using the circuit in [Figure 7-1](#), the requirement is to measure coil current up to 10A and drive the ADC input to a maximum of 3.3V. The OFFSET pin is grounded, so zero current results in a zero volt output.

### 7.1.1.2 Detailed Design Procedure

First, the value of  $R_{SENSE}$  must be determined.  $R_{SENSE}$  can be found by dividing the maximum desired output swing by the gain to determine the maximum input voltage. In this example, the LMP8601-Q1 is used, with a gain of 20V/V, as shown in [Equation 33](#):

$$V_{INMAX} = \frac{V_{OUTMAX}}{\text{Gain}} = \frac{3.3V}{20V/V} = 165mV \quad (33)$$

Knowing 165mV must be generated, the ideal value of the sense resistor can be determined through simple Ohm's law:

$$R_{SENSE} = \frac{V_{INMAX}}{I_{LOADMAX}} = \frac{165mV}{10A} = 16.4m\Omega \quad (34)$$

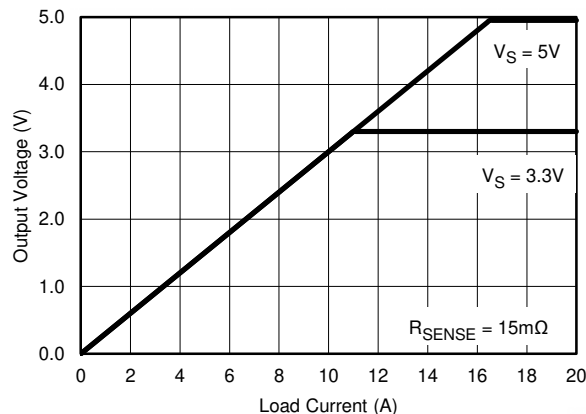
The ideal sense resistor value is 16.5mΩ. The closest standard value is 15mΩ, but this value can cause the output to slightly over-range at 10V. Reducing the expected maximum output by a few percentages is recommended to allow for overloads and component tolerances. The next most popular values are 10mΩ, 15mΩ, and 20mΩ. 10mΩ allows for a maximum output of 2V at 10A, but can be too low and not use the full output range. 20mΩ provides more sensitivity, but limits the maximum current to 8.25A. 15mΩ is a good compromise at 11A maximum, and allows for some component tolerance variation.

If a suitable sense resistor value is not available, adjusting the gain is also possible as detailed in the [Section 6.4.1](#) section.

The sense resistor does dissipates power, so the maximum wattage rating and appropriate power deratings must be observed. In the example above, the sense resistor dissipates  $0.165V \times 10A = 1.65W$ , so a sense resistor of at least twice the maximum expected power must be used (greater than 4W).

### 7.1.1.3 Application Curve

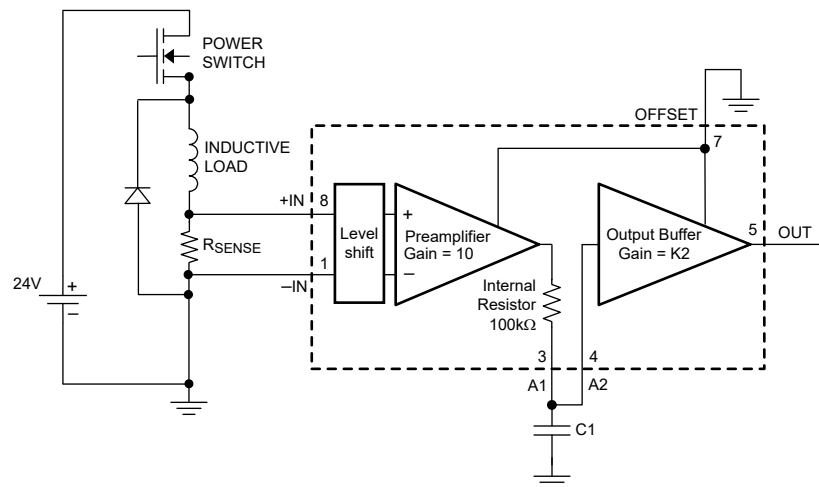
Below is the expected output value using a 15mΩ sense resistor.



**Figure 7-2. Expected Output Voltage vs Load Current Using 15mΩ Sense Resistor**

### 7.1.2 Low-Side, Current-Sensing Application

Figure 7-3 illustrates a low-side, current-sensing application with a low-side driver. The power transistor is pulse width modulated to control the average current flowing through the inductive load which is connected to a relatively high battery voltage. The current through the load is measured across a shunt resistor  $R_{SENSE}$  in series with the load. When the power transistor is on, current flows from the battery through the inductive load, the shunt resistor and the power transistor to ground. In this case, the common-mode voltage on the shunt is close to ground. When the power transistor is off, current flows through the inductive load, through the shunt resistor and through the freewheeling diode. In this case the common-mode voltage on the shunt is at least one diode voltage drop above the battery voltage. Therefore, in this application the common-mode voltage on the shunt is varying between a large positive voltage and a relatively low voltage. Because the large common-mode voltage range of the LMP860x-Q1 and because of the high ac common-mode rejection ratio, the LMP860x-Q1 are very well suited for this application.



$$R_{SENSE} = 0.01\Omega, K2 = 2, V_{OUT} = 0.2V/A$$

**Figure 7-3. Low-Side Current-Sensing Application**

For this application, the following example can be used for the calculation of the sense voltage ( $V_{SENSE}$ ):

When using a sense resistor,  $R_{SENSE}$ , of  $0.01\Omega$  and a current,  $I_{LOAD}$ , of 1A, the sense voltage at the input pins of the LMP860x-Q1 is:

$$V_{SENSE} = R_{SENSE} \times I_{LOAD} = 0.01\Omega \times 1A = 0.01V \quad (35)$$

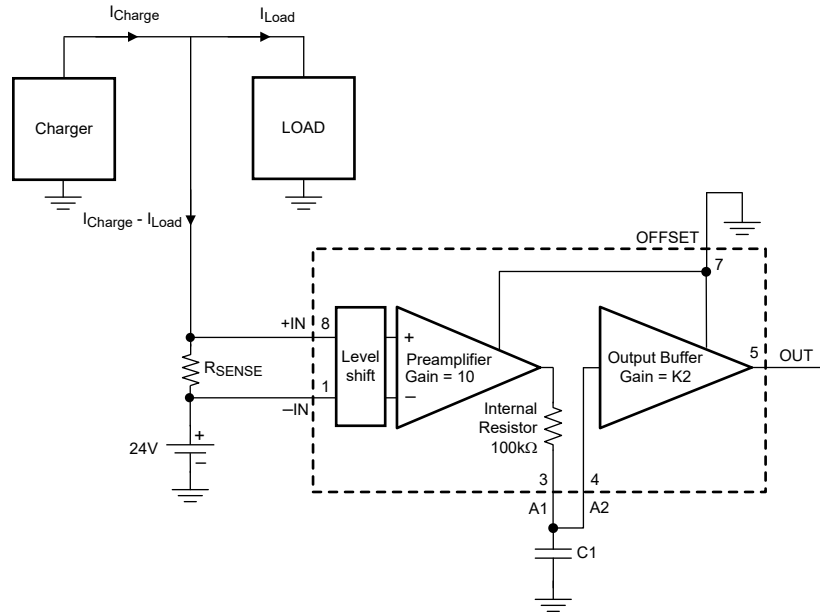
With the gain of 20 for the LMP8601-Q1, the result is an output of 0.2V. Or in other words,  $V_{OUT} = 0.2V/A$ .

For the LMP8602-Q1 with a gain of 50, the output is 0.5V/A.

For the LMP8603-Q1 with a gain of 100, the output is 1V/A.

### 7.1.3 Battery Current Monitor Application

This application example shows how the LMP860x-Q1 can be used to monitor the current flowing in and out of a battery pack. The fact that the LMP860x-Q1 can measure small voltages at a high offset voltage outside the parts own supply range makes this part a very good choice for such applications. If the load current of the battery is higher then the charging current, the output voltage of the LMP860x-Q1 is above the *half offset voltage* for a net current flowing out of the battery. When the charging current is higher then the load current the output is below this half offset voltage.

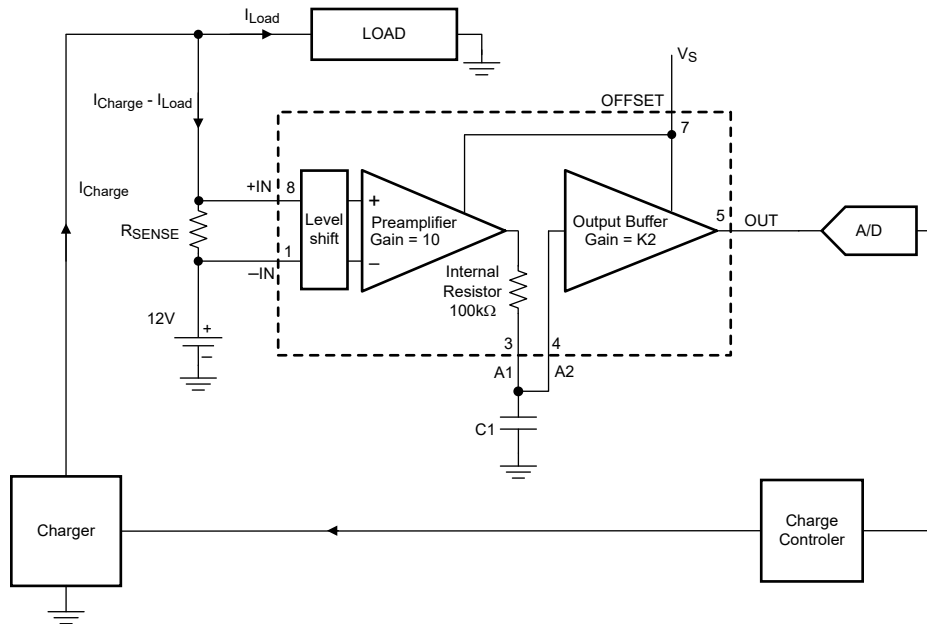


NOTE: K2 = 2 for LMP8601-Q1; 5 for LMP8602-Q1; or 10 for LMP8603-Q1.

**Figure 7-4. Battery Current Monitor Application**

### 7.1.4 Advanced Battery Charger Application

Figure 7-4 can be used to realize an advanced battery charger that has the capability to monitor the exact net current that flows in and out the battery as show in Figure 7-5. The output signal of the LMP860x-Q1 is digitized with the ADC and used as an input for the charge controller. The Charge controller can be used to regulate the charger circuit to deliver exactly the current that is required by the load, avoiding overcharging a fully loaded battery.

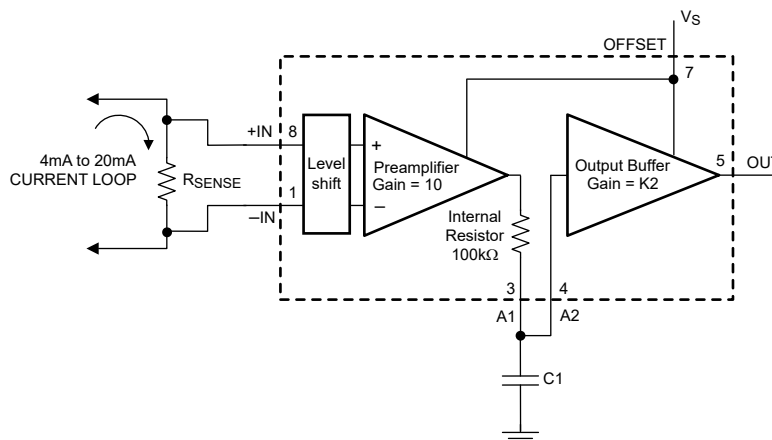


NOTE: K2 = 2 for LMP8601-Q1; 5 for LMP8602-Q1; or 10 for LMP8603-Q1.

**Figure 7-5. Advanced Battery Charger Application**

### 7.1.5 Current Loop Receiver Application

Many industrial applications use 4mA to 20mA transmitters to send an analog value of a sensor to a central control room. The LMP860x-Q1 can be used as a current loop receiver as shown in Figure 7-6.



NOTE: K2 = 2 for LMP8601-Q1; 5 for LMP8602-Q1; or 10 for LMP8603-Q1.

**Figure 7-6. Current-Loop Receiver Application**

### 7.1.6 Power Supply Recommendations

To decouple the LMP860x-Q1 from AC noise on the power supply, place a 0.1µF bypass capacitor between the  $V_S$  and GND pins. Place this capacitor as close as possible to the supply pins. In some cases, an additional 10µF bypass capacitor can further reduce the supply noise.

### 7.1.7 Layout

#### 7.1.7.1 Layout Guidelines

The traces leading to and from the sense resistor can be significant error sources. With small value sense resistors ( $< 100\text{m}\Omega$ ), any trace resistance shared with the load current can cause significant errors.

The amplifier inputs must be directly connected to the sense resistor pads using Kelvin or 4-wire connection techniques. The traces must be one continuous piece of copper from the sense resistor pad to the amplifier input pin pad, and preferably on the same copper layer with minimal vias or connectors. This can be important around the sense resistor if the resistor is generating any significant heat gradients.

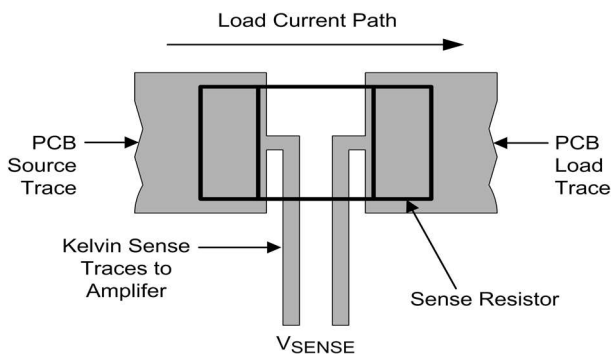
To minimize noise pickup and thermal errors, the input traces must be treated as a differential signal pair and routed tightly together with a direct path to the input pins. The input traces must be run away from noise sources, such as digital lines, switching supplies or motor drive lines. Remember that these traces can contain high voltage, and must have the appropriate trace routing clearances.

Since the sense traces only carry the amplifier bias current, the connecting input traces can be thinner, signal level traces. Excessive Resistance in the trace must also be avoided.

The paths of the traces must be identical, including connectors and vias, so that any errors are equal and cancel.

The sense resistor heats up as the load increases. As the resistor heats up, the resistance generally increases, which causes a change in the readings. The sense resistor must have as much heatsinking as possible to remove this heat through the use of heatsinks or large copper areas coupled to the resistor pads. A reading drifting over time after turnon can typically be traced back to sense resistor heating.

#### 7.1.7.2 Layout Example



**Figure 7-7. Kelvin or 4-wire Connection to the Sense Resistor**

## 8 Device and Documentation Support

### 8.1 Device Support

#### 8.1.1 Development Support

LMP8601 TINA SPICE Model, [SNOM084](#)

TINA-TI SPICE-Based Analog Simulation Program, <http://www.ti.com/tool/tina-ti>

### 8.2 Documentation Support

#### 8.2.1 Related Documentation

- Texas Instruments, [AN-1940 LMP8601 Evaluation Board](#), EVM user's guide
- Texas Instruments, [AN-1940 LMP8601 Evaluation Board](#), EVM user's guide

#### 8.2.2 Related Links

[Table 8-1](#) lists quick access links. Categories include technical documents, support and community resources, tools and software, and quick access to sample or buy.

**Table 8-1. Related Links**

PARTS	PRODUCT FOLDER	SAMPLE & BUY	TECHNICAL DOCUMENTS	TOOLS & SOFTWARE	SUPPORT & COMMUNITY
LMP8601	<a href="#">Click here</a>	<a href="#">Click here</a>	<a href="#">Click here</a>	<a href="#">Click here</a>	<a href="#">Click here</a>
LMP8601Q1	<a href="#">Click here</a>	<a href="#">Click here</a>	<a href="#">Click here</a>	<a href="#">Click here</a>	<a href="#">Click here</a>
LMP8602	<a href="#">Click here</a>	<a href="#">Click here</a>	<a href="#">Click here</a>	<a href="#">Click here</a>	<a href="#">Click here</a>
LMP8602Q1	<a href="#">Click here</a>	<a href="#">Click here</a>	<a href="#">Click here</a>	<a href="#">Click here</a>	<a href="#">Click here</a>
LMP8603	<a href="#">Click here</a>	<a href="#">Click here</a>	<a href="#">Click here</a>	<a href="#">Click here</a>	<a href="#">Click here</a>
LMP8603Q1	<a href="#">Click here</a>	<a href="#">Click here</a>	<a href="#">Click here</a>	<a href="#">Click here</a>	<a href="#">Click here</a>

### 8.3 Receiving Notification of Documentation Updates

To receive notification of documentation updates, navigate to the device product folder on [ti.com](http://ti.com). Click on *Notifications* to register and receive a weekly digest of any product information that has changed. For change details, review the revision history included in any revised document.

### 8.4 Support Resources

[TI E2E™ support forums](#) are an engineer's go-to source for fast, verified answers and design help — straight from the experts. Search existing answers or ask your own question to get the quick design help you need.

Linked content is provided "AS IS" by the respective contributors. They do not constitute TI specifications and do not necessarily reflect TI's views; see TI's [Terms of Use](#).

### 8.5 Trademarks

TI E2E™ is a trademark of Texas Instruments.  
 All trademarks are the property of their respective owners.

### 8.6 Electrostatic Discharge Caution



This integrated circuit can be damaged by ESD. Texas Instruments recommends that all integrated circuits be handled with appropriate precautions. Failure to observe proper handling and installation procedures can cause damage.

ESD damage can range from subtle performance degradation to complete device failure. Precision integrated circuits may be more susceptible to damage because very small parametric changes could cause the device not to meet its published specifications.

### 8.7 Glossary

[TI Glossary](#) This glossary lists and explains terms, acronyms, and definitions.

## 9 Revision History

NOTE: Page numbers for previous revisions may differ from page numbers in the current version.

<b>Changes from Revision H (April 2016) to Revision I (June 2026)</b>	<b>Page</b>
• Moved the commercial device to a standalone data sheet (SLVSJ15).....	1
• Updated the numbering format for tables, figures, and cross-references throughout the document.....	1
• Deleted device Machine Model ESD Classification from the <i>Features</i> Section .....	1
• Added Functional Safety-Capable document to the <i>Features</i> Section .....	1
• Updated applications with links.....	1
• Added Abs Max differential input voltage specification per TI standard .....	3
• Deleted Machine Model ESD rating.....	3
• Updated thermal Information for D (SOIC) package.....	3
• Changed common-mode input impedance values for SOIC (D) package.....	4
• Changed differential-mode input impedance values for SOIC (D) package.....	4
• Changed typical input bias current specification.....	4
• Changed Common-mode input impedance values for SOIC(D) package.....	6
• Changed differential-mode input impedance values for SOIC (D) package.....	6
• Changed typical input bias current specification.....	6
• Updated Input Bias Current Over Temperature (A2 pin) at VS = 5V curves.....	9
• Added Vos Distribution at Vs =3.3V and Vs =5V plots for SOIC (D) package .....	9
• Added Vos drift vs Temperature plots for SOIC (D) package.....	9
• Added Gain Error Distribution plots for SOIC (D) package .....	9
• Added Gain drift vs Temperature plots for SOIC (D) package .....	9
• Added CMMR Distribution plots for SOIC (D) package .....	9
• Added CMRR drift vs Temperature plots for SOIC (D) package .....	9
• Added the <i>Related Documentation</i> section.....	34

<b>Changes from Revision G (July 2015) to Revision H (April 2016)</b>	<b>Page</b>
• Added new temperature grade 0 version of LMP8601Q1.....	1
• Added LMP8602, LMP8602Q1, LMP8603, and LMP8603Q1 devices and related information to data sheet...	1
• Changed <i>Features</i> bullets .....	1
• Changed text in <i>Description</i> section.....	1
• Deleted <i>Related Documentation</i> section; SNOSB36 data sheet content now combined with this data sheet.	34

<b>Changes from Revision F (January 2014) to Revision G (April 2015)</b>	<b>Page</b>
• Added <i>ESD Ratings</i> table, and <i>Pin Configuration and Functions</i> , <i>Feature Description</i> , <i>Device Functional Modes</i> , <i>Application and Implementation</i> , <i>Power Supply Recommendations</i> , <i>Layout</i> , <i>Device and Documentation Support</i> , and <i>Mechanical, Packaging, and Orderable Information</i> sections.....	1

<b>Changes from Revision E (March 2013) to Revision F (January 2014)</b>	<b>Page</b>
• Added four typical curves.....	9

<b>Changes from Revision D (October 2009) to Revision E (March 2013)</b>	<b>Page</b>
• Changed layout of National Semiconductor Data Sheet to TI format.....	32

## 10 Mechanical, Packaging, and Orderable Information

The following pages include mechanical, packaging, and orderable information. This information is the most current data available for the designated devices. This data is subject to change without notice and revision of this document. For browser-based versions of this data sheet, refer to the left-hand navigation.

**PACKAGING INFORMATION**

Orderable part number	Status (1)	Material type (2)	Package   Pins	Package qty   Carrier	RoHS (3)	Lead finish/ Ball material (4)	MSL rating/ Peak reflow (5)	Op temp (°C)	Part marking (6)
<a href="#">LMP8601EDRQ1</a>	Active	Production	SOIC (D)   8	2500   LARGE T&R	Yes	SN	Level-1-260C-UNLIM	-40 to 150	LMP86 01EDQ1
LMP8601EDRQ1.A	Active	Production	SOIC (D)   8	2500   LARGE T&R	Yes	SN	Level-1-260C-UNLIM	-40 to 150	LMP86 01EDQ1
<a href="#">LMP8601QMA/NOPB</a>	Obsolete	Production	SOIC (D)   8	-	-	Call TI	Call TI	-40 to 125	LMP86 01QMA
<a href="#">LMP8601QMAX/NOPB</a>	Active	Production	SOIC (D)   8	2500   LARGE T&R	Yes	SN	Level-1-260C-UNLIM	-40 to 125	LMP86 01QMA
LMP8601QMAX/NOPB.A	Active	Production	SOIC (D)   8	2500   LARGE T&R	Yes	SN	Level-1-260C-UNLIM	-40 to 125	LMP86 01QMA
<a href="#">LMP8602QMA/NOPB</a>	Obsolete	Production	SOIC (D)   8	-	-	Call TI	Call TI	-40 to 125	LMP86 02QMA
<a href="#">LMP8602QMAX/NOPB</a>	Active	Production	SOIC (D)   8	2500   LARGE T&R	Yes	SN	Level-1-260C-UNLIM	-40 to 125	LMP86 02QMA
LMP8602QMAX/NOPB.A	Active	Production	SOIC (D)   8	2500   LARGE T&R	Yes	SN	Level-1-260C-UNLIM	-40 to 125	LMP86 02QMA
<a href="#">LMP8602QMM/NOPB</a>	Obsolete	Production	VSSOP (DGK)   8	-	-	Call TI	Call TI	-40 to 125	AF7A
<a href="#">LMP8602QMME/NOPB</a>	Obsolete	Production	VSSOP (DGK)   8	-	-	Call TI	Call TI	-40 to 125	AF7A
<a href="#">LMP8602QMMX/NOPB</a>	Active	Production	VSSOP (DGK)   8	3500   LARGE T&R	Yes	SN	Level-1-260C-UNLIM	-40 to 125	AF7A
LMP8602QMMX/NOPB.A	Active	Production	VSSOP (DGK)   8	3500   LARGE T&R	Yes	SN	Level-1-260C-UNLIM	-40 to 125	AF7A
<a href="#">LMP8603QMA/NOPB</a>	Obsolete	Production	SOIC (D)   8	-	-	Call TI	Call TI	-40 to 125	LMP86 03QMA
<a href="#">LMP8603QMAX/NOPB</a>	Active	Production	SOIC (D)   8	2500   LARGE T&R	Yes	SN	Level-1-260C-UNLIM	-40 to 125	LMP86 03QMA
LMP8603QMAX/NOPB.A	Active	Production	SOIC (D)   8	2500   LARGE T&R	Yes	SN	Level-1-260C-UNLIM	-40 to 125	LMP86 03QMA
<a href="#">LMP8603QMM/NOPB</a>	Obsolete	Production	VSSOP (DGK)   8	-	-	Call TI	Call TI	-40 to 125	AH7A
<a href="#">LMP8603QMME/NOPB</a>	Obsolete	Production	VSSOP (DGK)   8	-	-	Call TI	Call TI	-40 to 125	AH7A
<a href="#">LMP8603QMMX/NOPB</a>	Active	Production	VSSOP (DGK)   8	3500   LARGE T&R	Yes	SN	Level-1-260C-UNLIM	-40 to 125	AH7A
LMP8603QMMX/NOPB.A	Active	Production	VSSOP (DGK)   8	3500   LARGE T&R	Yes	SN	Level-1-260C-UNLIM	-40 to 125	AH7A

(1) **Status:** For more details on status, see our [product life cycle](#).

- (2) **Material type:** When designated, preproduction parts are prototypes/experimental devices, and are not yet approved or released for full production. Testing and final process, including without limitation quality assurance, reliability performance testing, and/or process qualification, may not yet be complete, and this item is subject to further changes or possible discontinuation. If available for ordering, purchases will be subject to an additional waiver at checkout, and are intended for early internal evaluation purposes only. These items are sold without warranties of any kind.
- (3) **RoHS values:** Yes, No, RoHS Exempt. See the [TI RoHS Statement](#) for additional information and value definition.
- (4) **Lead finish/Ball material:** Parts may have multiple material finish options. Finish options are separated by a vertical ruled line. Lead finish/Ball material values may wrap to two lines if the finish value exceeds the maximum column width.
- (5) **MSL rating/Peak reflow:** The moisture sensitivity level ratings and peak solder (reflow) temperatures. In the event that a part has multiple moisture sensitivity ratings, only the lowest level per JEDEC standards is shown. Refer to the shipping label for the actual reflow temperature that will be used to mount the part to the printed circuit board.
- (6) **Part marking:** There may be an additional marking, which relates to the logo, the lot trace code information, or the environmental category of the part.

Multiple part markings will be inside parentheses. Only one part marking contained in parentheses and separated by a "~" will appear on a part. If a line is indented then it is a continuation of the previous line and the two combined represent the entire part marking for that device.

**Important Information and Disclaimer:**The information provided on this page represents TI's knowledge and belief as of the date that it is provided. TI bases its knowledge and belief on information provided by third parties, and makes no representation or warranty as to the accuracy of such information. Efforts are underway to better integrate information from third parties. TI has taken and continues to take reasonable steps to provide representative and accurate information but may not have conducted destructive testing or chemical analysis on incoming materials and chemicals. TI and TI suppliers consider certain information to be proprietary, and thus CAS numbers and other limited information may not be available for release.

In no event shall TI's liability arising out of such information exceed the total purchase price of the TI part(s) at issue in this document sold by TI to Customer on an annual basis.

**OTHER QUALIFIED VERSIONS OF LMP8601-Q1, LMP8602-Q1, LMP8603-Q1 :**

- Catalog : [LMP8601](#), [LMP8602](#), [LMP8603](#)

NOTE: Qualified Version Definitions:

- Catalog - TI's standard catalog product

**TAPE AND REEL INFORMATION**

**QUADRANT ASSIGNMENTS FOR PIN 1 ORIENTATION IN TAPE**


\*All dimensions are nominal

Device	Package Type	Package Drawing	Pins	SPQ	Reel Diameter (mm)	Reel Width W1 (mm)	A0 (mm)	B0 (mm)	K0 (mm)	P1 (mm)	W (mm)	Pin1 Quadrant
LMP8601EDRQ1	SOIC	D	8	2500	330.0	12.4	6.5	5.4	2.0	8.0	12.0	Q1
LMP8601MAX/NOPB	SOIC	D	8	2500	330.0	12.4	6.5	5.4	2.0	8.0	12.0	Q1
LMP8601QMAX/NOPB	SOIC	D	8	2500	330.0	12.4	6.5	5.4	2.0	8.0	12.0	Q1
LMP8602MAX/NOPB	SOIC	D	8	2500	330.0	12.4	6.5	5.4	2.0	8.0	12.0	Q1
LMP8602MMX/NOPB	VSSOP	DGK	8	3500	330.0	12.4	5.3	3.4	1.4	8.0	12.0	Q1
LMP8602QMAX/NOPB	SOIC	D	8	2500	330.0	12.4	6.5	5.4	2.0	8.0	12.0	Q1
LMP8602QMMX/NOPB	VSSOP	DGK	8	3500	330.0	12.4	5.3	3.4	1.4	8.0	12.0	Q1
LMP8603MAX/NOPB	SOIC	D	8	2500	330.0	12.4	6.5	5.4	2.0	8.0	12.0	Q1
LMP8603MMX/NOPB	VSSOP	DGK	8	3500	330.0	12.4	5.3	3.4	1.4	8.0	12.0	Q1
LMP8603QMAX/NOPB	SOIC	D	8	2500	330.0	12.4	6.5	5.4	2.0	8.0	12.0	Q1
LMP8603QMMX/NOPB	VSSOP	DGK	8	3500	330.0	12.4	5.3	3.4	1.4	8.0	12.0	Q1

**TAPE AND REEL BOX DIMENSIONS**


\*All dimensions are nominal

Device	Package Type	Package Drawing	Pins	SPQ	Length (mm)	Width (mm)	Height (mm)
LMP8601EDRQ1	SOIC	D	8	2500	356.0	356.0	35.0
LMP8601MAX/NOPB	SOIC	D	8	2500	356.0	356.0	35.0
LMP8601QMAX/NOPB	SOIC	D	8	2500	356.0	356.0	35.0
LMP8602MAX/NOPB	SOIC	D	8	2500	356.0	356.0	35.0
LMP8602MMX/NOPB	VSSOP	DGK	8	3500	356.0	356.0	35.0
LMP8602QMAX/NOPB	SOIC	D	8	2500	356.0	356.0	35.0
LMP8602QMMX/NOPB	VSSOP	DGK	8	3500	356.0	356.0	35.0
LMP8603MAX/NOPB	SOIC	D	8	2500	356.0	356.0	35.0
LMP8603MMX/NOPB	VSSOP	DGK	8	3500	356.0	356.0	35.0
LMP8603QMAX/NOPB	SOIC	D	8	2500	356.0	356.0	35.0
LMP8603QMMX/NOPB	VSSOP	DGK	8	3500	356.0	356.0	35.0



D0008A

# PACKAGE OUTLINE

SOIC - 1.75 mm max height

SMALL OUTLINE INTEGRATED CIRCUIT



4214825/C 02/2019

### NOTES:

- Linear dimensions are in inches [millimeters]. Dimensions in parenthesis are for reference only. Controlling dimensions are in inches. Dimensioning and tolerancing per ASME Y14.5M.
- This drawing is subject to change without notice.
- This dimension does not include mold flash, protrusions, or gate burrs. Mold flash, protrusions, or gate burrs shall not exceed  $.006$  [0.15] per side.
- This dimension does not include interlead flash.
- Reference JEDEC registration MS-012, variation AA.

# EXAMPLE BOARD LAYOUT

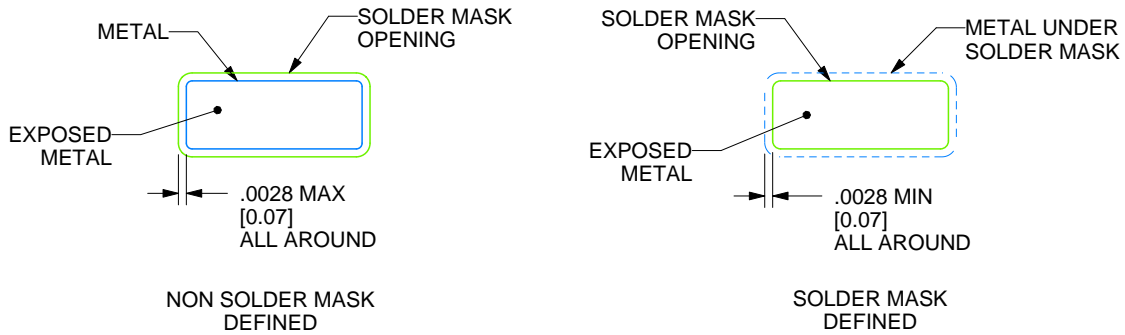
D0008A

SOIC - 1.75 mm max height

SMALL OUTLINE INTEGRATED CIRCUIT



LAND PATTERN EXAMPLE  
 EXPOSED METAL SHOWN  
 SCALE:8X



SOLDER MASK DETAILS

4214825/C 02/2019

NOTES: (continued)

- 6. Publication IPC-7351 may have alternate designs.
- 7. Solder mask tolerances between and around signal pads can vary based on board fabrication site.

# EXAMPLE STENCIL DESIGN

D0008A

SOIC - 1.75 mm max height

SMALL OUTLINE INTEGRATED CIRCUIT



SOLDER PASTE EXAMPLE  
BASED ON .005 INCH [0.125 MM] THICK STENCIL  
SCALE:8X

4214825/C 02/2019

NOTES: (continued)

8. Laser cutting apertures with trapezoidal walls and rounded corners may offer better paste release. IPC-7525 may have alternate design recommendations.
9. Board assembly site may have different recommendations for stencil design.

# DGK0008A



# PACKAGE OUTLINE

VSSOP - 1.1 mm max height

SMALL OUTLINE PACKAGE



4214862/A 04/2023

**NOTES:**

PowerPAD is a trademark of Texas Instruments.

1. All linear dimensions are in millimeters. Any dimensions in parenthesis are for reference only. Dimensioning and tolerancing per ASME Y14.5M.
2. This drawing is subject to change without notice.
3. This dimension does not include mold flash, protrusions, or gate burrs. Mold flash, protrusions, or gate burrs shall not exceed 0.15 mm per side.
4. This dimension does not include interlead flash. Interlead flash shall not exceed 0.25 mm per side.
5. Reference JEDEC registration MO-187.

# EXAMPLE BOARD LAYOUT

DGK0008A

™ VSSOP - 1.1 mm max height

SMALL OUTLINE PACKAGE



LAND PATTERN EXAMPLE  
EXPOSED METAL SHOWN  
SCALE: 15X



SOLDER MASK DETAILS

4214862/A 04/2023

NOTES: (continued)

6. Publication IPC-7351 may have alternate designs.
7. Solder mask tolerances between and around signal pads can vary based on board fabrication site.
8. Vias are optional depending on application, refer to device data sheet. If any vias are implemented, refer to their locations shown on this view. It is recommended that vias under paste be filled, plugged or tented.
9. Size of metal pad may vary due to creepage requirement.

# EXAMPLE STENCIL DESIGN

DGK0008A

<sup>TM</sup> VSSOP - 1.1 mm max height

SMALL OUTLINE PACKAGE



SOLDER PASTE EXAMPLE  
SCALE: 15X

4214862/A 04/2023

NOTES: (continued)

11. Laser cutting apertures with trapezoidal walls and rounded corners may offer better paste release. IPC-7525 may have alternate design recommendations.
12. Board assembly site may have different recommendations for stencil design.

## IMPORTANT NOTICE AND DISCLAIMER

TI PROVIDES TECHNICAL AND RELIABILITY DATA (INCLUDING DATASHEETS), DESIGN RESOURCES (INCLUDING REFERENCE DESIGNS), APPLICATION OR OTHER DESIGN ADVICE, WEB TOOLS, SAFETY INFORMATION, AND OTHER RESOURCES "AS IS" AND WITH ALL FAULTS, AND DISCLAIMS ALL WARRANTIES, EXPRESS AND IMPLIED, INCLUDING WITHOUT LIMITATION ANY IMPLIED WARRANTIES OF MERCHANTABILITY, FITNESS FOR A PARTICULAR PURPOSE OR NON-INFRINGEMENT OF THIRD PARTY INTELLECTUAL PROPERTY RIGHTS.

These resources are intended for skilled developers designing with TI products. You are solely responsible for (1) selecting the appropriate TI products for your application, (2) designing, validating and testing your application, and (3) ensuring your application meets applicable standards, and any other safety, security, regulatory or other requirements.

These resources are subject to change without notice. TI grants you permission to use these resources only for development of an application that uses the TI products described in the resource. Other reproduction and display of these resources is prohibited. No license is granted to any other TI intellectual property right or to any third party intellectual property right. TI disclaims responsibility for, and you fully indemnify TI and its representatives against any claims, damages, costs, losses, and liabilities arising out of your use of these resources.

TI's products are provided subject to [TI's Terms of Sale](#), [TI's General Quality Guidelines](#), or other applicable terms available either on [ti.com](http://ti.com) or provided in conjunction with such TI products. TI's provision of these resources does not expand or otherwise alter TI's applicable warranties or warranty disclaimers for TI products. Unless TI explicitly designates a product as custom or customer-specified, TI products are standard, catalog, general purpose devices.

TI objects to and rejects any additional or different terms you may propose.

Copyright © 2026, Texas Instruments Incorporated

Last updated 10/2025