

ESD451 1-Channel ±30kV Bidirectional ESD Diode in an 0201 and 0402 Package

1 Features

- IEC 61000-4-2 level 4 ESD protection:
 - ±30kV contact discharge
 - ±30kV air gap discharge
- IEC 61000-4-5 surge protection:
 - 6A (8/20µs)
- IO capacitance:
 - 0.5pF (typical)
- DC breakdown voltage: ±8V (typical)
- Ultra low leakage current: 50nA (maximum)
- Extremely low ESD clamping voltage
 - 10.4V at 16A TLP
 - R_{DYN} : 0.19Ω
- Low insertion loss: 3.5GHz (-3dB bandwidth)
- Supports high speed interfaces up to 6Gbps
- Industrial temperature range: -55°C to +150°C
- Space saving industry standard 0201 (0.6mm x 0.3mm) and 0402 footprint (1.0mm x 0.6mm)

2 Applications

- End equipment:
 - Vacuum robots
 - Wearables
 - Smart speakers
 - Portable electronics
 - Small appliances
 - Retail automation and payment
 - Laptops and desktops
 - TV and monitors
 - Docking stations
- Interfaces:
 - USB 3.0
 - HDMI™ 1.4 and 2.0
 - DisplayPort™
 - SIM card

3 Description

The ESD451 is a bidirectional ESD protection diode for protecting data line and other I/O ports. The ESD451 is rated to dissipate ESD strikes up to ±30kV per the IEC 61000-4-2 international standard (greater than Level 4).

This device features a 0.5pF (typical) IO capacitance enabling high-speed interface protection for protocols such as USB 3.0. The extremely low dynamic resistance (0.19Ω) and clamping voltage (10.4V at 16A TLP) is specified for system-level protection against transient events.

The ±30kV ESD rating and 6A surge provides robust transient protection in a tiny package for protecting 5.5V power rails and data lines in portable electronics and other space constrained applications such as wearables.

The ESD451 is offered in the industry standard 0201 and 0402 package.

Package Information

PART NUMBER	PACKAGE ⁽¹⁾	PACKAGE SIZE ⁽²⁾
ESD451	DPL (DFN0603, 2)	0.6mm × 0.3mm
	DPY (DFN1006, 2)	1.0mm × 0.6mm

(1) For all available packages, see the orderable addendum at the end of the data sheet.

(2) The package size (length × width) is a nominal value and includes pins, where applicable.

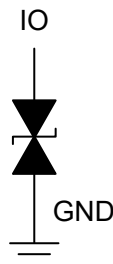

Functional Block Diagram

Table of Contents

1 Features	1	6 Application and Implementation	10
2 Applications	1	6.1 Application Information.....	10
3 Description	1	7 Device and Documentation Support	11
4 Pin Configuration and Functions	3	7.1 Documentation Support.....	11
5 Specifications	4	7.2 Receiving Notification of Documentation Updates....	11
5.1 Absolute Maximum Ratings.....	4	7.3 Support Resources.....	11
5.2 ESD Ratings—JEDEC Specification.....	4	7.4 Trademarks.....	11
5.3 ESD Ratings—IEC Specification.....	4	7.5 Electrostatic Discharge Caution.....	11
5.4 Recommended Operating Conditions.....	4	7.6 Glossary.....	11
5.5 Thermal Information.....	4	8 Revision History	11
5.6 Electrical Characteristics.....	6	9 Mechanical, Packaging, and Orderable Information..	12
5.7 Typical Characteristics.....	7		

4 Pin Configuration and Functions

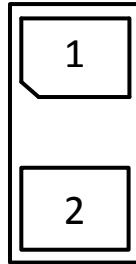

Figure 4-1. DPL Package, 2-Pin DFN0603 (Top View)

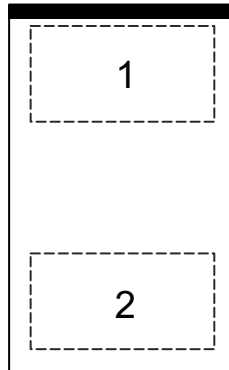

Figure 4-2. DPY Package, 2-Pin DFN1006 (Top View)

Table 4-1. Pin Functions

PIN		TYPE ⁽¹⁾	DESCRIPTION
NAME	NO.		
IO	1	I/O	ESD Protected Channel. If used as ESD IO, connect pin 2 to ground
IO	2	I/O	ESD Protected Channel. If used as ESD IO, connect pin 1 to ground

(1) I = input, O = output

5 Specifications

5.1 Absolute Maximum Ratings

over operating free-air temperature range (unless otherwise noted) ⁽¹⁾

		MIN	MAX	UNIT
Peak Pulse ^{(2) (3)}	IEC 61000-4-5 power (t_p - 8/20 μ s)		57	W
	IEC 61000-4-5 Current (t_p - 8/20 μ s)		6	A
T_A	Ambient Operating Temperature	-55	150	°C
T_{stg}	Storage Temperature	-65	155	°C

- (1) Operation outside the Absolute Maximum Ratings may cause permanent device damage. Absolute maximum ratings do not imply functional operation of the device at these or any other conditions beyond those listed under Recommended Operating Conditions. If briefly operating outside the Recommended Operating Conditions but within the Absolute Maximum Ratings, the device may not sustain damage, but it may not be fully functional. Operating the device in this manner may affect device reliability, functionality, performance, and shorten the device lifetime.
- (2) Voltages are with respect to GND unless otherwise noted.
- (3) Measured at 25°C

5.2 ESD Ratings—JEDEC Specification

			VALUE	UNIT
$V_{(ESD)}$	Electrostatic discharge	Human body model (HBM), per ANSI/ESDA/JEDEC JS-001 ⁽¹⁾	±2500	V
		Charged device model (CDM), per JEDEC specification JS-002 ⁽²⁾	±1000	V

- (1) JEDEC document JEP155 states that 500V HBM allows safe manufacturing with a standard ESD control process.
- (2) JEDEC document JEP157 states that 250V CDM allows safe manufacturing with a standard ESD control process.

5.3 ESD Ratings—IEC Specification

			VALUE	UNIT
$V_{(ESD)}$	Electrostatic discharge	IEC 61000-4-2 contact discharge	±30000	V
		IEC 61000-4-2 air-gap discharge	±30000	

5.4 Recommended Operating Conditions

over operating free-air temperature range (unless otherwise noted)

			MIN	NOM	MAX	UNIT
V_{IO}	Input pin voltage	IO to GND	-5.5		5.5	V
T_A	Operating free-air temperature		-55		150	°C

5.5 Thermal Information

THERMAL METRIC ⁽¹⁾		ESD451		UNIT
		DPL (DFN0603)	DPY (DFN1006)	
		2 PINS	2 PINS	
$R_{\theta JA}$	Junction-to-ambient thermal resistance	356.9	305.0	°C/W
$R_{\theta JC(top)}$	Junction-to-case (top) thermal resistance	201.2	179.5	°C/W
$R_{\theta JB}$	Junction-to-board thermal resistance	136.4	121.4	°C/W
Ψ_{JT}	Junction-to-top characterization parameter	2.6	16.5	°C/W
Ψ_{JB}	Junction-to-board characterization parameter	135.9	120.3	°C/W

THERMAL METRIC ⁽¹⁾		ESD451		UNIT
		DPL (DFN0603)	DPY (DFN1006)	
		2 PINS	2 PINS	
$R_{\theta JC(bot)}$	Junction-to-case (bottom) thermal resistance	NA	NA	°C/W

- (1) For more information about traditional and new thermal metrics, see the [Semiconductor and IC Package Thermal Metrics](#) application note.

5.6 Electrical Characteristics

At TA=25°C (unless otherwise noted) ⁽¹⁾

PARAMETER		PACKAGE	TEST CONDITION	MIN	TYP	MAX	UNIT
V _{RWM}	Reverse stand-off voltage	DPL & DPY package	I _{IO} < 100nA, across operating temperature range	-5.5		5.5	V
I _{LEAK}	Reverse leakage current		V _{IO} = 5.5V, IO to GND or GND to IO		5	50	nA
V _{BR}	Break-down voltage		I _{IO} = 1mA, IO to GND	7	8	9	V
V _{CLAMP}	Clamping voltage with TLP	DPL Package	I _{PP} = 1A, TLP, IO to GND		7.6		V
			I _{PP} = 5A, TLP, IO to GND		8.2		
			I _{PP} = 16A, TLP, IO to GND		10.4		
			I _{PP} = 1A, TLP, GND to IO		7.6		
			I _{PP} = 5A, TLP, GND to IO		8.2		
			I _{PP} = 16A, TLP, GND to IO		10.4		
	Clamping voltage with surge strike ⁽³⁾		I _{PP} = 6A, t _p = 8/20μs, IO to GND		9.5		
			I _{PP} = 6A, t _p = 8/20μs, GND to IO		9.5		
R _{DYN}	Dynamic resistance ⁽²⁾		IO to GND		0.19		Ω
			GND to IO		0.19		
V _{CLAMP}	Clamping voltage with TLP	DPY Package	I _{PP} = 1A, TLP, IO to GND		8.2		V
			I _{PP} = 5A, TLP, IO to GND		9.2		
			I _{PP} = 16A, TLP, IO to GND		11.5		
			I _{PP} = 1A, TLP, GND to IO		8.2		
			I _{PP} = 5A, TLP, GND to IO		9.2		
			I _{PP} = 16A, TLP, GND to IO		11.5		
	Clamping voltage with surge strike ⁽³⁾		I _{PP} = 6A, t _p = 8/20μs, IO to GND		10		
			I _{PP} = 6A, t _p = 8/20μs, GND to IO		10		
R _{DYN}	Dynamic resistance ⁽²⁾		IO to GND		0.24		Ω
			GND to IO		0.24		
C _L	Line capacitance	DPL & DPY Package	V _{IO} = 0V; f = 1MHz, V _{pp} = 30mV, IO to GND or IO to GND		0.5		pF

(1) Typical parameters are measured at 25°C

(2) Extraction of R_{DYN} using least squares fit of TLP characteristics between I = 10A and I = 20A

(3) Nonrepetitive current pulse 8 to 20μs exponentially decaying waveform according to IEC 61000-4-5

5.7 Typical Characteristics

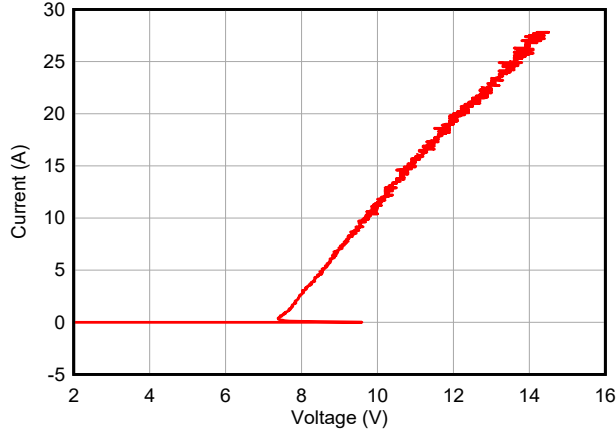

Figure 5-1. Positive TLP Curve (DPL)

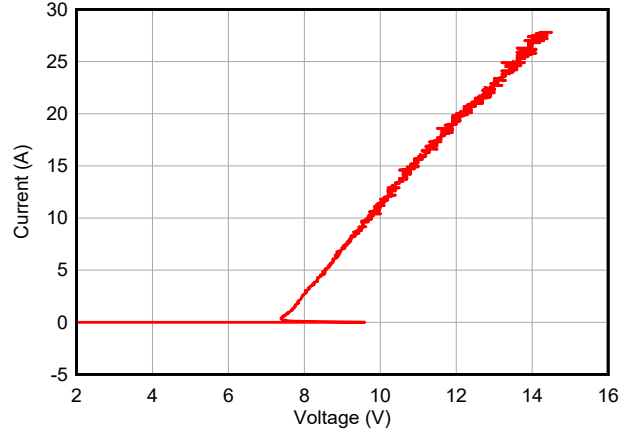

Figure 5-2. Negative TLP Curve (DPL)

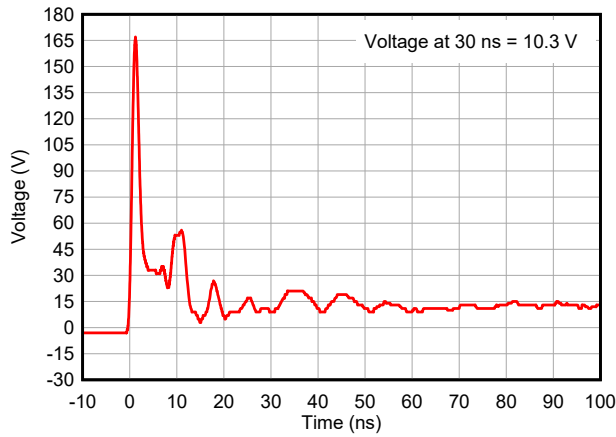

Figure 5-3. +8kV Clamped IEC Waveform (DPL)

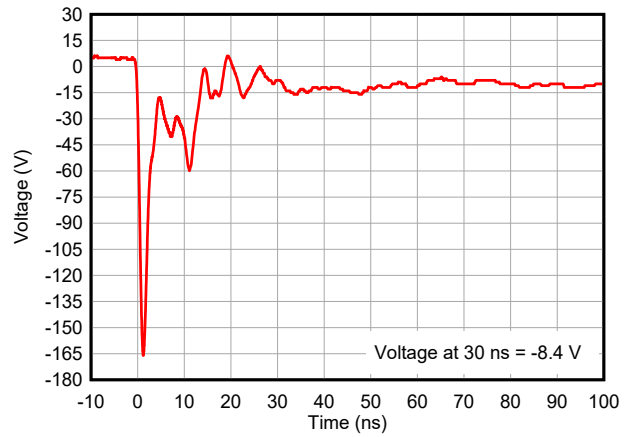

Figure 5-4. -8kV Clamped IEC Waveform (DPL)

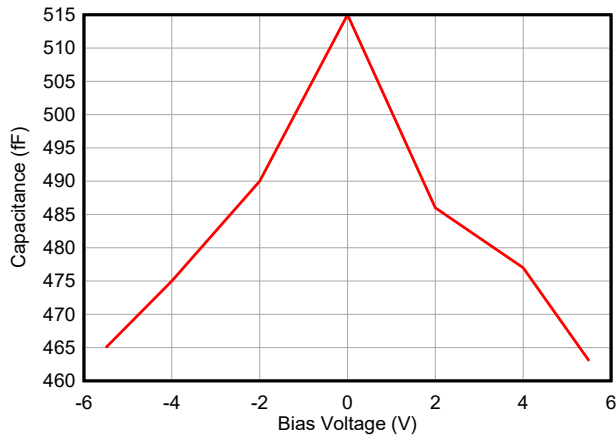

Figure 5-5. Bias Voltage vs. Capacitance (DPL)

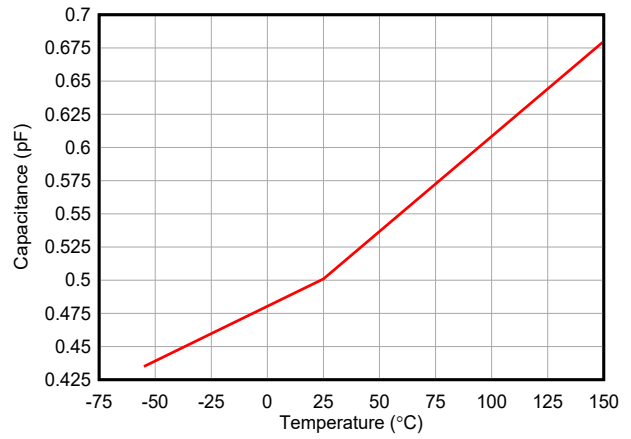

Figure 5-6. Temperature vs. Capacitance (DPL)

5.7 Typical Characteristics (continued)

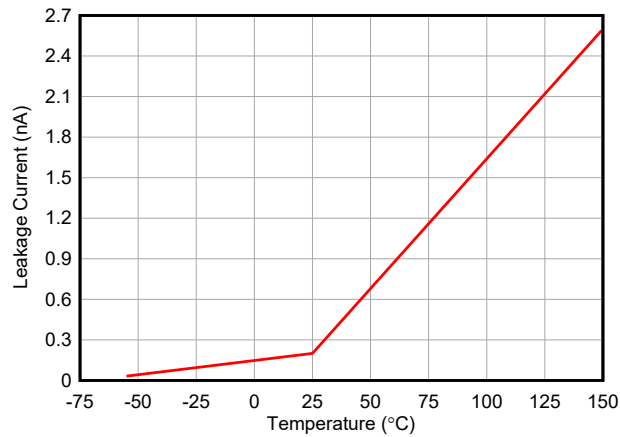

Figure 5-7. Temperature vs. Leakage Current (DPL)

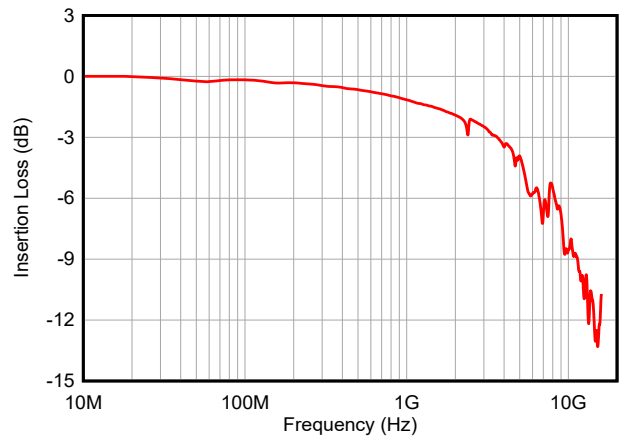

Figure 5-8. Insertion Loss (DPL)

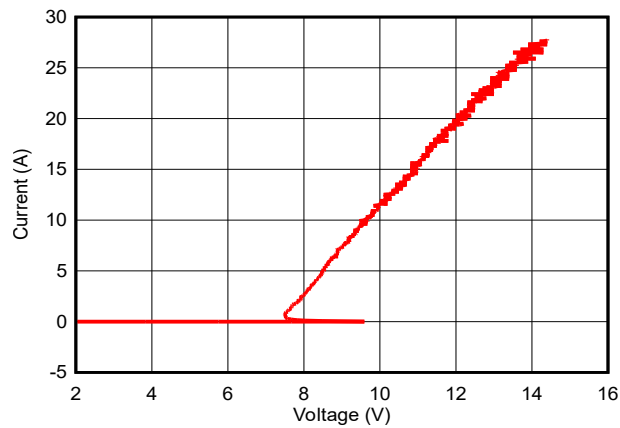

Figure 5-9. Positive TLP Curve (DPY)

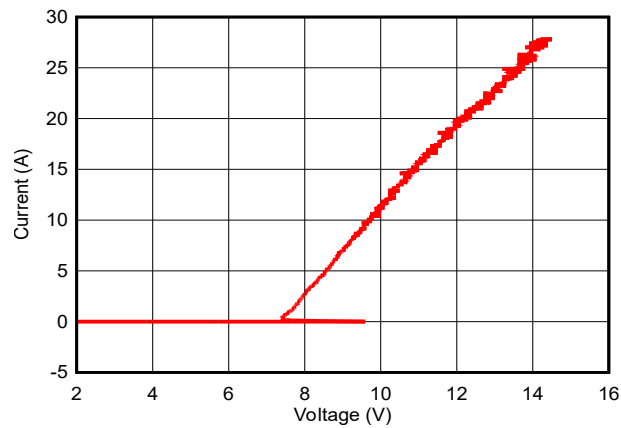

Figure 5-10. Negative TLP Curve (DPY)

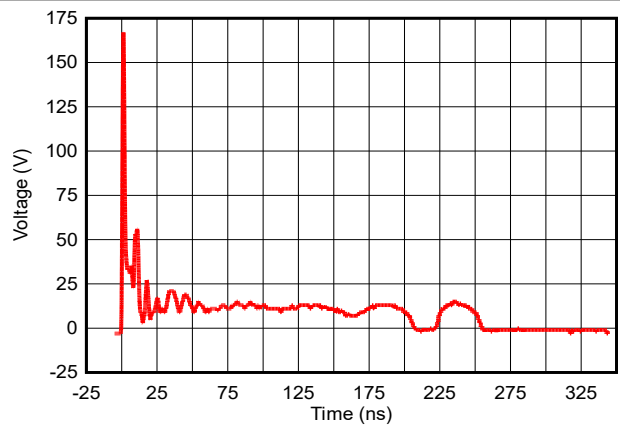

Figure 5-11. +8kV Clamped IEC Waveform (DPY)

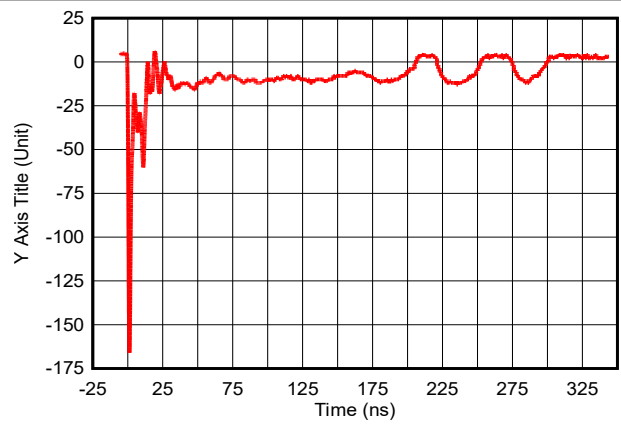

Figure 5-12. -8kV Clamped IEC Waveform (DPY)

5.7 Typical Characteristics (continued)

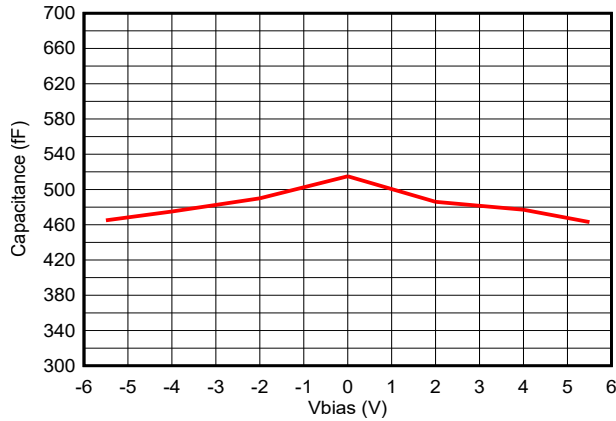

Figure 5-13. Bias Voltage vs. Capacitance (DPY)

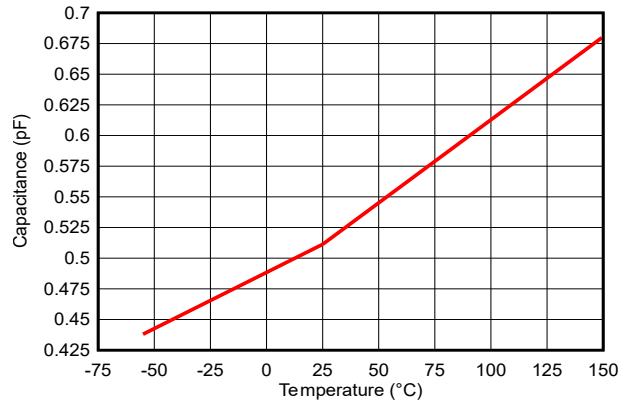

Figure 5-14. Temperature vs. Capacitance (DPY)

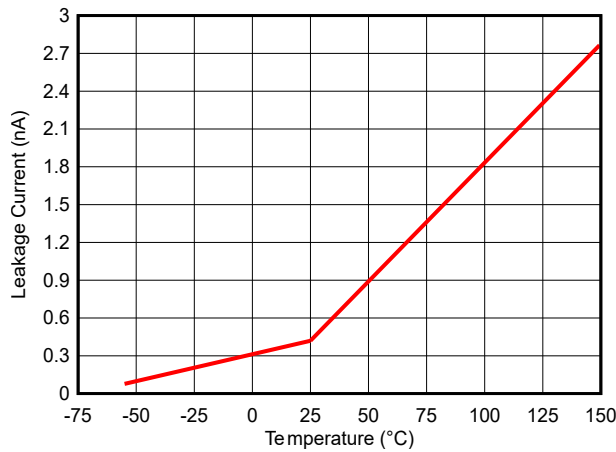

Figure 5-15. Temperature vs. Leakage Current (DPY)

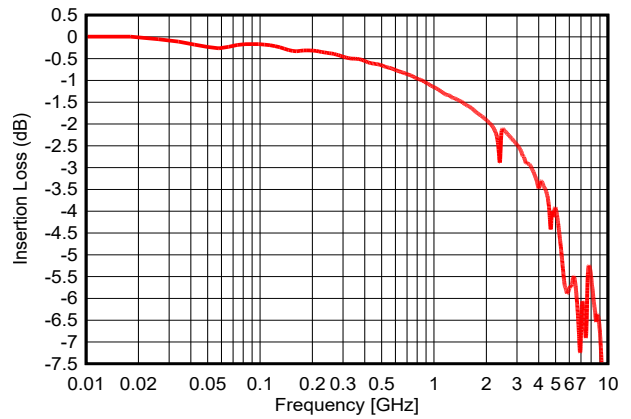

Figure 5-16. Insertion Loss (DPY)

6 Application and Implementation

Note

Information in the following applications sections is not part of the TI component specification, and TI does not warrant its accuracy or completeness. TI's customers are responsible for determining suitability of components for their purposes, as well as validating and testing their design implementation to confirm system functionality.

6.1 Application Information

The ESD451 is a diode type TVS which provides a path to ground for dissipating transient voltage spikes, such as ESD or surge, on signal lines and power lines. The device should be connected in parallel to the down stream circuitry it is protecting. As the current from the transient passes through the TVS, only a small voltage drop is present across the diode. This is the voltage presented to the protected IC. The low R_{DYN} of the triggered TVS holds this voltage (V_{CLAMP}) to a safe level for the protected IC. For more information on how to properly use this device, please refer to the [ESD Packaging and Layout Guide](#) for details.

7 Device and Documentation Support

7.1 Documentation Support

7.1.1 Related Documentation

For related documentation, see the following:

- Texas Instruments, [ESD Layout Guide application reports](#)
- Texas Instruments, [Generic ESD Evaluation Module user's guide](#)
- Texas Instruments, [Picking ESD Diodes for Ultra High-Speed Data Lines application reports](#)
- Texas Instruments, [Reading and Understanding an ESD Protection data sheet](#)

7.2 Receiving Notification of Documentation Updates

To receive notification of documentation updates, navigate to the device product folder on ti.com. Click on *Notifications* to register and receive a weekly digest of any product information that has changed. For change details, review the revision history included in any revised document.

7.3 Support Resources

[TI E2E™ support forums](#) are an engineer's go-to source for fast, verified answers and design help — straight from the experts. Search existing answers or ask your own question to get the quick design help you need.

Linked content is provided "AS IS" by the respective contributors. They do not constitute TI specifications and do not necessarily reflect TI's views; see TI's [Terms of Use](#).

7.4 Trademarks

HDMI™ is a trademark of HDMI Licensing LLC.

DisplayPort™ is a trademark of Video Electronics Standards Association.

TI E2E™ is a trademark of Texas Instruments.

All trademarks are the property of their respective owners.

7.5 Electrostatic Discharge Caution



This integrated circuit can be damaged by ESD. Texas Instruments recommends that all integrated circuits be handled with appropriate precautions. Failure to observe proper handling and installation procedures can cause damage.

ESD damage can range from subtle performance degradation to complete device failure. Precision integrated circuits may be more susceptible to damage because very small parametric changes could cause the device not to meet its published specifications.

7.6 Glossary

[TI Glossary](#) This glossary lists and explains terms, acronyms, and definitions.

8 Revision History

NOTE: Page numbers for previous revisions may differ from page numbers in the current version.

Changes from Revision A (June 2023) to Revision B (December 2025)	Page
• Added DPY package throughout the data sheet.....	1
• Updated surge value in <i>Features</i> to match surge value in <i>Electrical Characteristics</i> table.....	1

Changes from Revision * (April 2023) to Revision A (June 2023)	Page
• Changed the status of the data sheet from: <i>Advanced Information</i> to: <i>Production Data</i>	1

9 Mechanical, Packaging, and Orderable Information

The following pages include mechanical, packaging, and orderable information. This information is the most current data available for the designated devices. This data is subject to change without notice and revision of this document. For browser-based versions of this data sheet, refer to the left-hand navigation.

PACKAGING INFORMATION

Orderable part number	Status (1)	Material type (2)	Package Pins	Package qty Carrier	RoHS (3)	Lead finish/ Ball material (4)	MSL rating/ Peak reflow (5)	Op temp (°C)	Part marking (6)
ESD451DPLR	Active	Production	X2SON (DPL) 2	15000 LARGE T&R	Yes	NIPDAU	Level-1-260C-UNLIM	-40 to 125	G
ESD451DPLR.B	Active	Production	X2SON (DPL) 2	15000 LARGE T&R	Yes	NIPDAU	Level-1-260C-UNLIM	-40 to 125	G
ESD451DPYR	Active	Production	X1SON (DPY) 2	10000 LARGE T&R	Yes	SN	Level-1-260C-UNLIM	-40 to 125	S3

(1) **Status:** For more details on status, see our [product life cycle](#).

(2) **Material type:** When designated, preproduction parts are prototypes/experimental devices, and are not yet approved or released for full production. Testing and final process, including without limitation quality assurance, reliability performance testing, and/or process qualification, may not yet be complete, and this item is subject to further changes or possible discontinuation. If available for ordering, purchases will be subject to an additional waiver at checkout, and are intended for early internal evaluation purposes only. These items are sold without warranties of any kind.

(3) **RoHS values:** Yes, No, RoHS Exempt. See the [TI RoHS Statement](#) for additional information and value definition.

(4) **Lead finish/Ball material:** Parts may have multiple material finish options. Finish options are separated by a vertical ruled line. Lead finish/Ball material values may wrap to two lines if the finish value exceeds the maximum column width.

(5) **MSL rating/Peak reflow:** The moisture sensitivity level ratings and peak solder (reflow) temperatures. In the event that a part has multiple moisture sensitivity ratings, only the lowest level per JEDEC standards is shown. Refer to the shipping label for the actual reflow temperature that will be used to mount the part to the printed circuit board.

(6) **Part marking:** There may be an additional marking, which relates to the logo, the lot trace code information, or the environmental category of the part.

Multiple part markings will be inside parentheses. Only one part marking contained in parentheses and separated by a "-" will appear on a part. If a line is indented then it is a continuation of the previous line and the two combined represent the entire part marking for that device.

Important Information and Disclaimer: The information provided on this page represents TI's knowledge and belief as of the date that it is provided. TI bases its knowledge and belief on information provided by third parties, and makes no representation or warranty as to the accuracy of such information. Efforts are underway to better integrate information from third parties. TI has taken and continues to take reasonable steps to provide representative and accurate information but may not have conducted destructive testing or chemical analysis on incoming materials and chemicals. TI and TI suppliers consider certain information to be proprietary, and thus CAS numbers and other limited information may not be available for release.

In no event shall TI's liability arising out of such information exceed the total purchase price of the TI part(s) at issue in this document sold by TI to Customer on an annual basis.

TAPE AND REEL INFORMATION

QUADRANT ASSIGNMENTS FOR PIN 1 ORIENTATION IN TAPE

*All dimensions are nominal

Device	Package Type	Package Drawing	Pins	SPQ	Reel Diameter (mm)	Reel Width W1 (mm)	A0 (mm)	B0 (mm)	K0 (mm)	P1 (mm)	W (mm)	Pin1 Quadrant
ESD451DPLR	X2SON	DPL	2	15000	178.0	8.4	0.36	0.66	0.33	2.0	8.0	Q1
ESD451DPYR	X1SON	DPY	2	10000	180.0	8.4	0.67	1.15	0.46	2.0	8.0	Q2

TAPE AND REEL BOX DIMENSIONS

*All dimensions are nominal

Device	Package Type	Package Drawing	Pins	SPQ	Length (mm)	Width (mm)	Height (mm)
ESD451DPLR	X2SON	DPL	2	15000	205.0	200.0	33.0
ESD451DPYR	X1SON	DPY	2	10000	210.0	185.0	35.0

GENERIC PACKAGE VIEW

DPY 2

X1SON - 0.45 mm max height

1 x 0.6 mm

PLASTIC SMALL OUTLINE - NO LEAD

This image is a representation of the package family, actual package may vary.
Refer to the product data sheet for package details.



4231484/A

DPY0002A

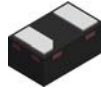

PACKAGE OUTLINE
X1SON - 0.45 mm max height

PLASTIC SMALL OUTLINE - NO LEAD

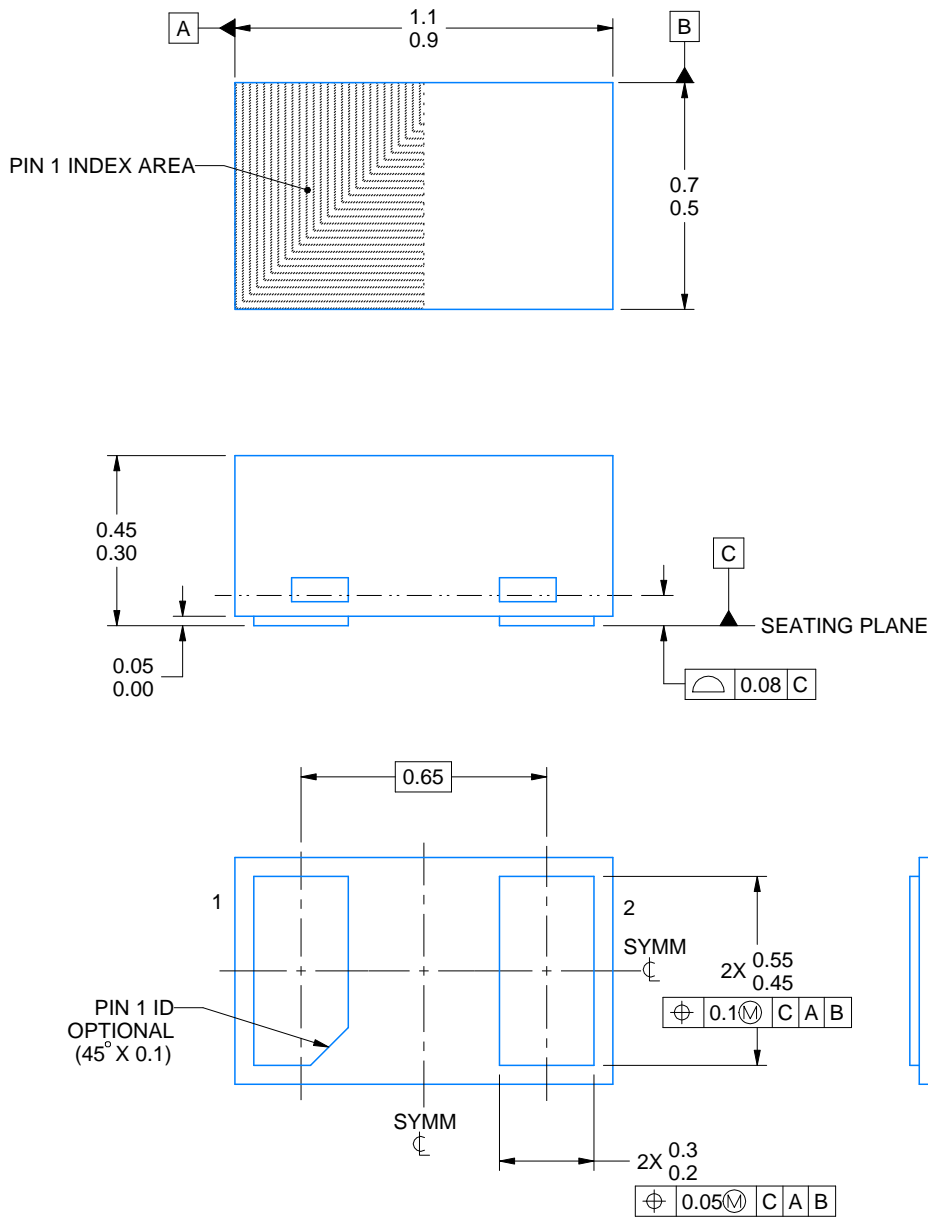

4224561/C 07/2024

NOTES:

1. All linear dimensions are in millimeters. Any dimensions in parenthesis are for reference only. Dimensioning and tolerancing per ASME Y14.5M
2. This drawing is subject to change without notice.

EXAMPLE BOARD LAYOUT

DPY0002A

X1SON - 0.45 mm max height

PLASTIC SMALL OUTLINE - NO LEAD

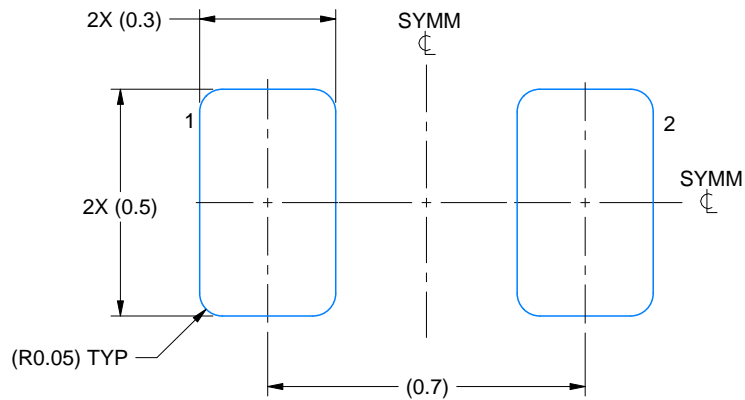

LAND PATTERN EXAMPLE
EXPOSED METAL SHOWN
SCALE:60X

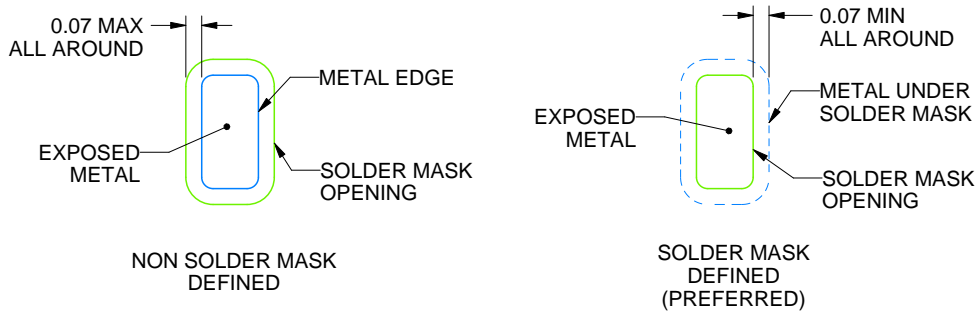

SOLDER MASK DETAILS

4224561/C 07/2024

NOTES: (continued)

3. For more information, see Texas Instruments literature number SLUA271 (www.ti.com/lit/sluea271).
4. Vias are optional depending on application, refer to device data sheet. If any vias are implemented, refer to their locations shown on this view. It is recommended that vias under paste be filled, plugged or tented.

EXAMPLE STENCIL DESIGN

DPY0002A

X1SON - 0.45 mm max height

PLASTIC SMALL OUTLINE - NO LEAD

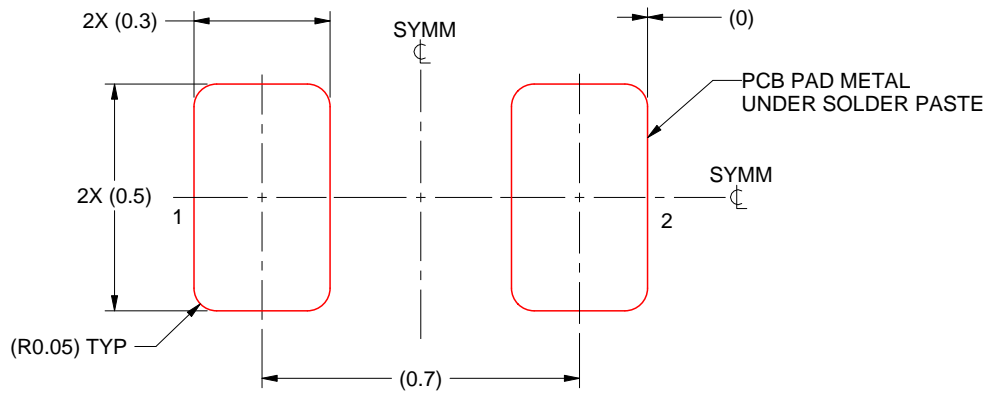

SOLDER PASTE EXAMPLE
BASED ON 0.1 mm THICK STENCIL
SCALE:60X

4224561/C 07/2024

NOTES: (continued)

5. Laser cutting apertures with trapezoidal walls and rounded corners may offer better paste release. IPC-7525 may have alternate design recommendations.

DPY0002B



PACKAGE OUTLINE

X1SON - 0.45 mm max height

PLASTIC SMALL OUTLINE - NO LEAD

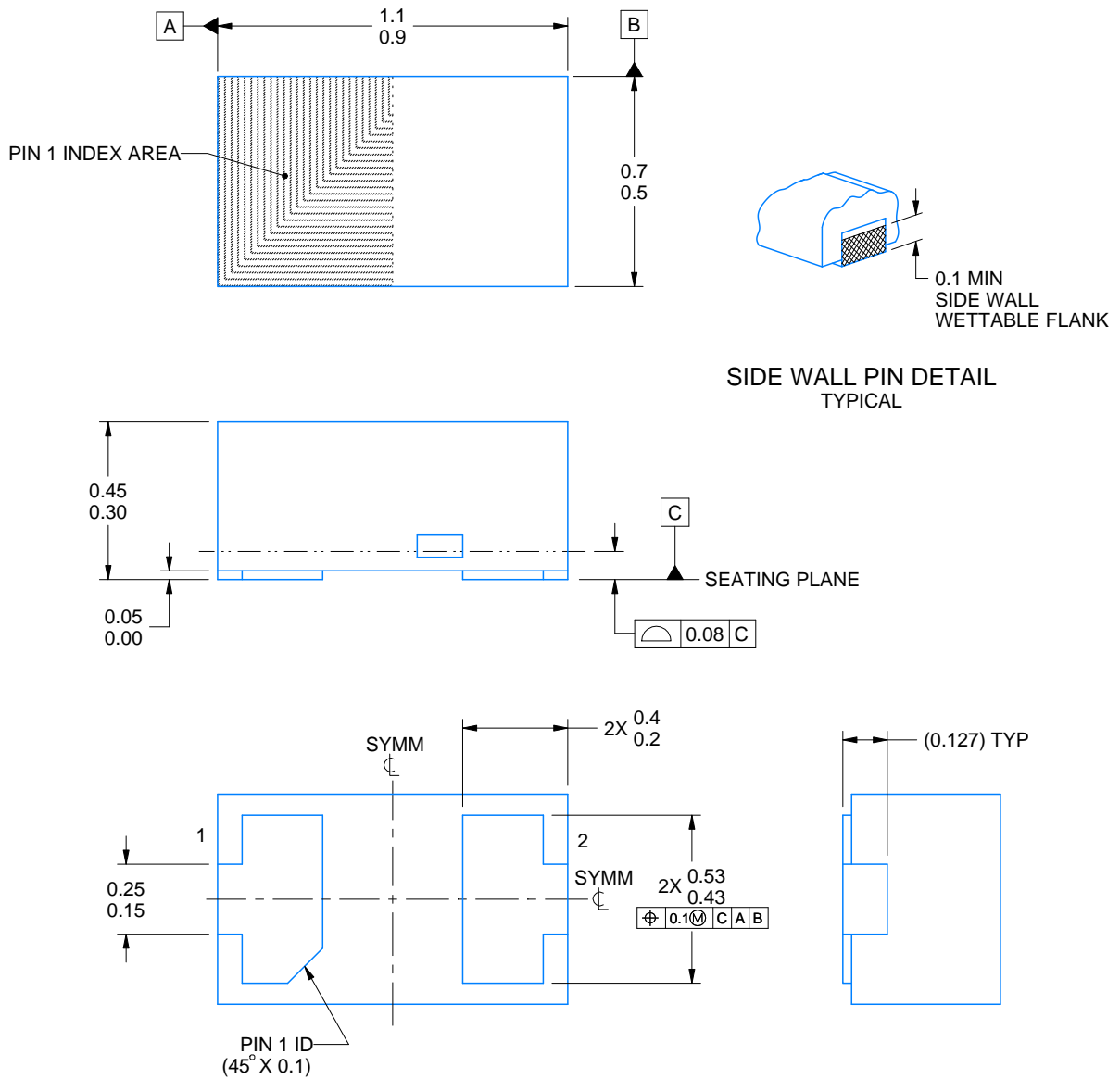

4231402/A 12/2024

NOTES:

1. All linear dimensions are in millimeters. Any dimensions in parenthesis are for reference only. Dimensioning and tolerancing per ASME Y14.5M
2. This drawing is subject to change without notice.

EXAMPLE BOARD LAYOUT

DPY0002B

X1SON - 0.45 mm max height

PLASTIC SMALL OUTLINE - NO LEAD

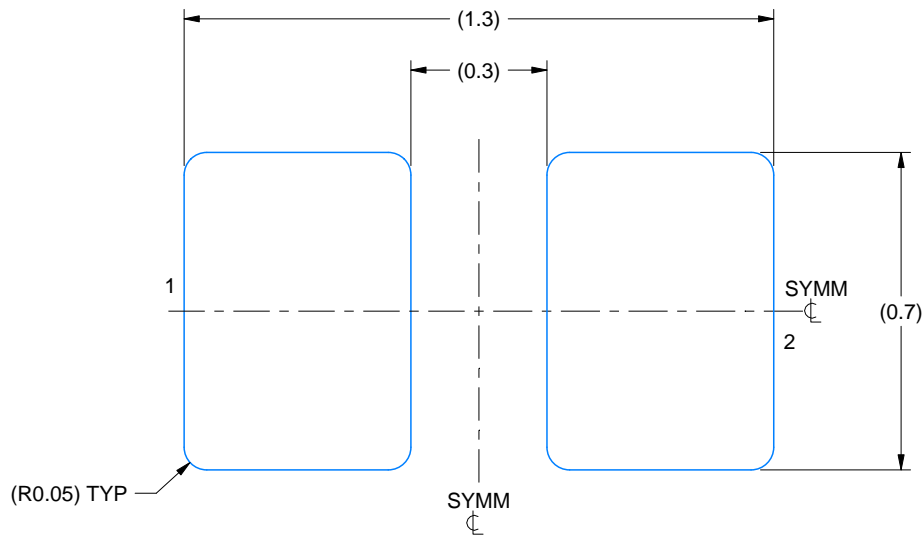

LAND PATTERN EXAMPLE
EXPOSED METAL SHOWN
SCALE:60X

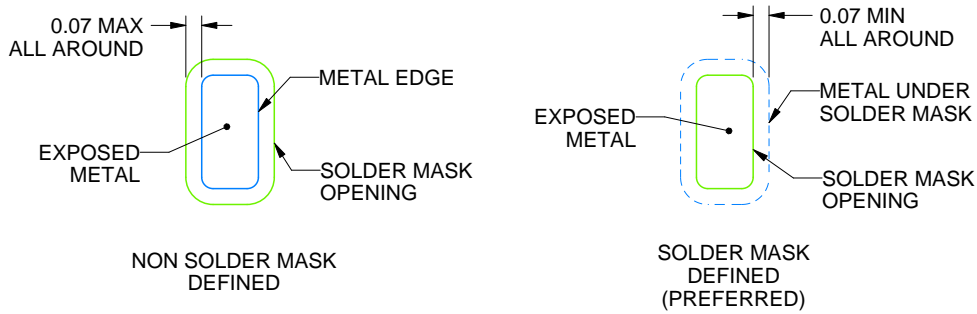

SOLDER MASK DETAILS

4231402/A 12/2024

NOTES: (continued)

3. For more information, see Texas Instruments literature number SLUA271 (www.ti.com/lit/slua271).

EXAMPLE STENCIL DESIGN

DPY0002B

X1SON - 0.45 mm max height

PLASTIC SMALL OUTLINE - NO LEAD

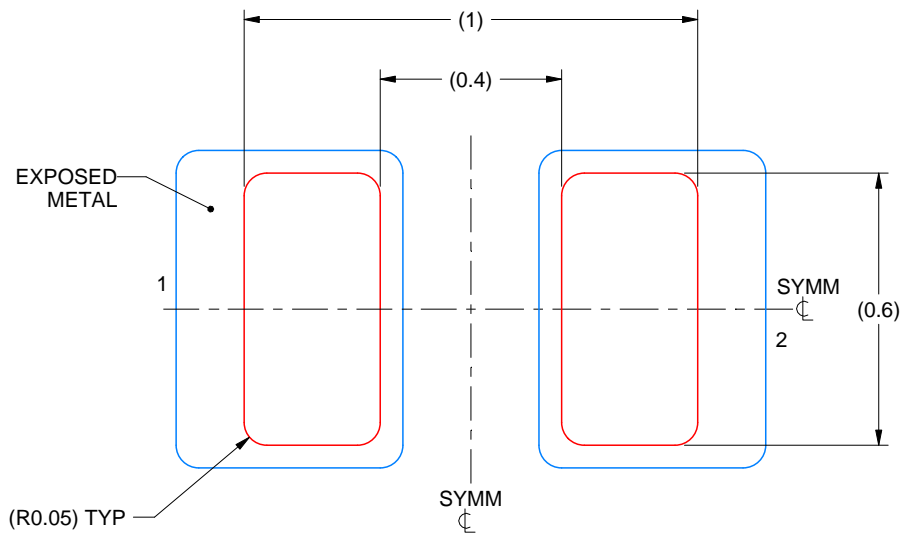

SOLDER PASTE EXAMPLE
BASED ON 0.1 mm THICK STENCIL
SCALE:60X

NOTES: (continued)

4. Laser cutting apertures with trapezoidal walls and rounded corners may offer better paste release. IPC-7525 may have alternate design recommendations.

MECHANICAL DATA

DPL (R-PX2SON-N2)

PLASTIC SMALL OUTLINE NO-LEAD

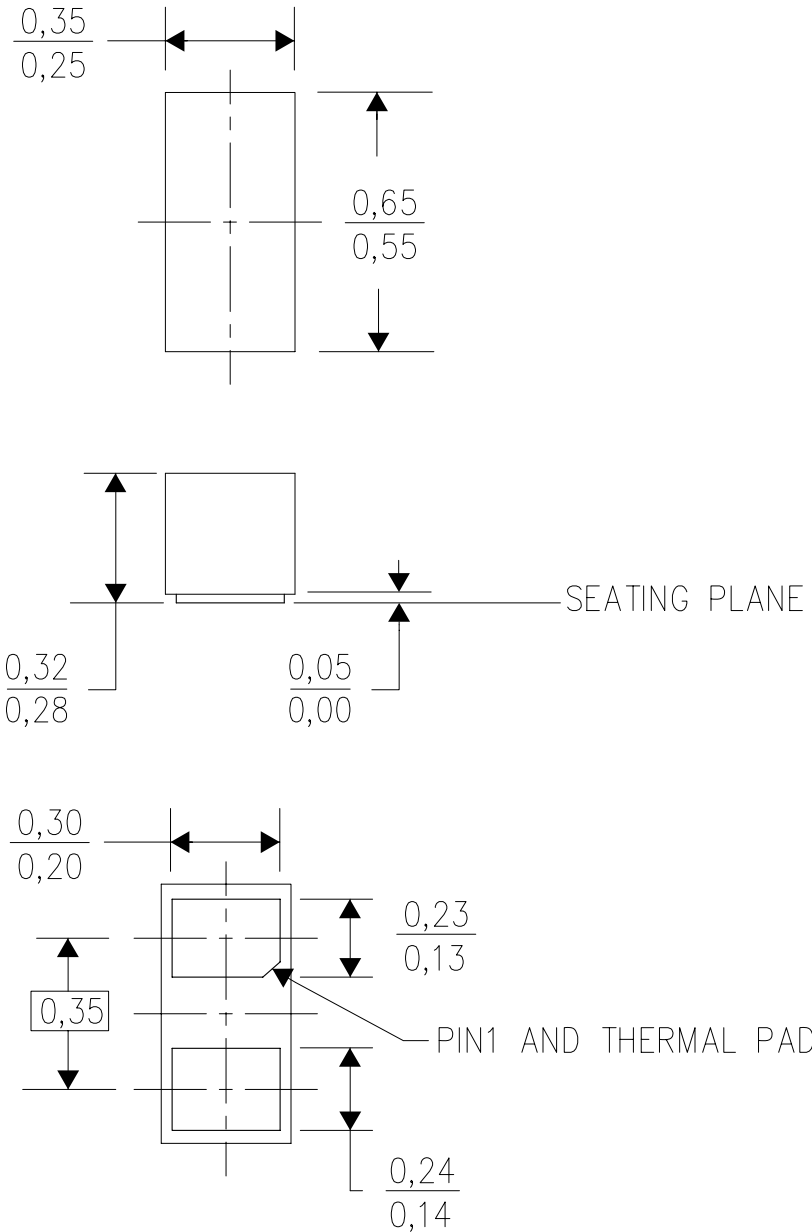

4212149/B 10/11

- NOTES:
- A. All linear dimensions are in millimeters. Dimensioning and tolerancing per ASME Y14.5M-1994.
 - B. This drawing is subject to change without notice.
 - C. Small Outline No-Lead (SON) package configuration.
 - D. The package thermal pad must be soldered to the board for thermal and mechanical performance.

Example Board Layout

Example Stencil Design
(Note E)

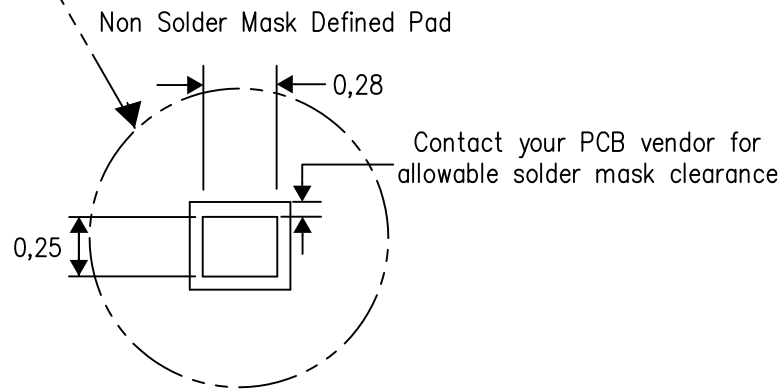
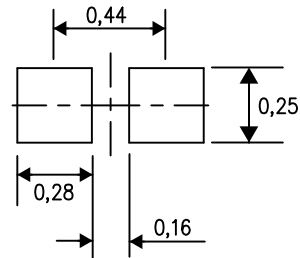
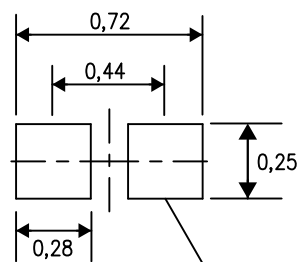

4217903/A 08/12

- NOTES:
- A. All linear dimensions are in millimeters.
 - B. This drawing is subject to change without notice.
 - C. Publication IPC-7351 is recommended for alternate designs.
 - D. Customers should contact their board fabrication site for minimum solder mask web tolerances between signal pads.
 - E. Maximum stencil thickness 0,127 mm (5 mils). All linear dimensions are in millimeters.
 - F. Laser cutting apertures with trapezoidal walls and also rounding corners will offer better paste release. Customers should contact their board assembly site for stencil design recommendations. Refer to IPC 7525 for stencil design considerations.
 - G. Side aperture dimensions over-print land for acceptable area ratio > 0.66. Customer may reduce side aperture dimensions if stencil manufacturing process allows for sufficient release at smaller opening.

IMPORTANT NOTICE AND DISCLAIMER

TI PROVIDES TECHNICAL AND RELIABILITY DATA (INCLUDING DATASHEETS), DESIGN RESOURCES (INCLUDING REFERENCE DESIGNS), APPLICATION OR OTHER DESIGN ADVICE, WEB TOOLS, SAFETY INFORMATION, AND OTHER RESOURCES "AS IS" AND WITH ALL FAULTS, AND DISCLAIMS ALL WARRANTIES, EXPRESS AND IMPLIED, INCLUDING WITHOUT LIMITATION ANY IMPLIED WARRANTIES OF MERCHANTABILITY, FITNESS FOR A PARTICULAR PURPOSE OR NON-INFRINGEMENT OF THIRD PARTY INTELLECTUAL PROPERTY RIGHTS.

These resources are intended for skilled developers designing with TI products. You are solely responsible for (1) selecting the appropriate TI products for your application, (2) designing, validating and testing your application, and (3) ensuring your application meets applicable standards, and any other safety, security, regulatory or other requirements.

These resources are subject to change without notice. TI grants you permission to use these resources only for development of an application that uses the TI products described in the resource. Other reproduction and display of these resources is prohibited. No license is granted to any other TI intellectual property right or to any third party intellectual property right. TI disclaims responsibility for, and you fully indemnify TI and its representatives against any claims, damages, costs, losses, and liabilities arising out of your use of these resources.

TI's products are provided subject to [TI's Terms of Sale](#), [TI's General Quality Guidelines](#), or other applicable terms available either on ti.com or provided in conjunction with such TI products. TI's provision of these resources does not expand or otherwise alter TI's applicable warranties or warranty disclaimers for TI products. Unless TI explicitly designates a product as custom or customer-specified, TI products are standard, catalog, general purpose devices.

TI objects to and rejects any additional or different terms you may propose.

Copyright © 2026, Texas Instruments Incorporated

Last updated 10/2025