



Introduction

The Telecommunications Industry Association (TIA) and Electronic Industries Alliance (EIA) standard for RS-485 communication was established two decades ago and has been widely adopted for a variety of applications. RS-485 is the ideal standard for reliable communication over long distances of 1000 meters because of the twisted pair structure used to send a differential signal.

For motor control, factory automation, grid infrastructure, and other systems where high voltages can be present, communication between high voltage and low voltage domains create a need to isolate nodes of the RS-485 system. Isolating an RS-485 node protects circuitry, and in some cases human operators, from high voltages and any unwanted transients. Isolation used to protect human operators from high voltages is referred to as reinforced isolation and is the equivalent of having two functional isolation barriers in series. Galvanic isolation is also used in RS-485 systems to prevent ground loops that can cause noise, which interferes with the RS-485 bus communication.

There are a variety of methods that can be implemented to isolate signal and power to achieve these system-level benefits. This article addresses the different solutions available for isolating an RS-485 node and explains the trade-offs between them.

Signal Isolation

There are two common methods for isolating the signal for an RS-485 system. The first method is a discrete solution of a digital isolator and RS-485 transceiver. In this solution, the enables (RE, DE), transmit (D), and receive (R) signals are isolated using a digital isolator such as the [ISO7741](#) between the MCU and the RS-485 transceiver. [Figure 1](#) shows an example of this solution with [ISO7741](#) and an RS-485 transceiver such as the [THVD1410](#). One key advantage of the discrete solution is the flexibility to choose the best transceiver for the specific application. However, the discrete solution comes with the drawback of requiring additional board space because of the multi-chip solution.

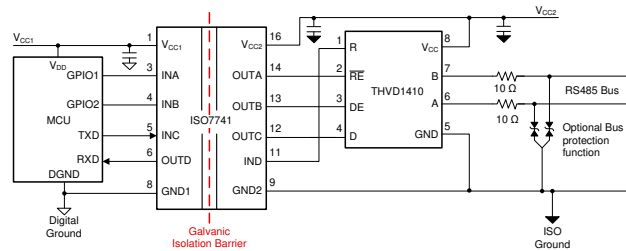

Figure 1. Discrete Implementation of Isolated RS-485 using ISO7741 and THVD1410

The second method is to use an integrated solution that combines the digital isolator and RS-485 transceiver in one package. The [ISO1410](#) integrates the core isolation technology from [ISO7741](#) and the [THVD1410](#) transceiver in single package. The core isolation technology leads to the capability to achieve 1500 Vpk continuous working voltage, reinforced 5 kVrms isolation rating, and 100 kV/us typical common mode transient immunity (CMTI). The integrated transceiver provides high noise immunity on the bus with Profibus compliance, 16 kV IEC electrostatic discharge (ESD), and 4 kV IEC electrical fast transients (EFT) to ensure reliable communication even in noisy environments like a factory floor. The [ISO1410](#) has the added benefit over the discrete solution of a wider logic side supply with support for 1.71 V to 5.5 V to enable lower logic level MCU's and 3 V to 5.5 V for the bus side supply.

By combining the isolator and transceiver into one package, this solution provides system-level board space reduction compared to the discrete solution. [Figure 2](#) shows how the discrete solution from [Figure 1](#) can be replaced with the [ISO1410](#).

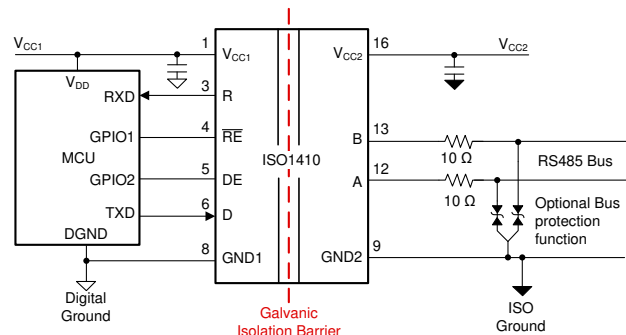

Figure 2. Integrated Solution for Isolated RS-485 using ISO1410

Power Isolation

Regardless of the method used to isolate the RS-485 signals, an isolated power supply is required to power the secondary side of the digital isolator and the RS-485 transceiver or isolated RS-485 device. The first solution for providing isolated power is shown in Figure 3, where the transformer driver, SN6501 in combination with an external transformer and LDO provides isolated power for the ISO1410. This solution can also be used with the discrete approach for signal isolation.

The benefit of this solution is that it provides greater than 80% efficiency and the transformer and LDO can be selected to optimize for specific design considerations. The SN6501 provides up to 1.5 W of power and can be replaced with the SN6505 for up to 5 W if isolated power is needed for additional devices.

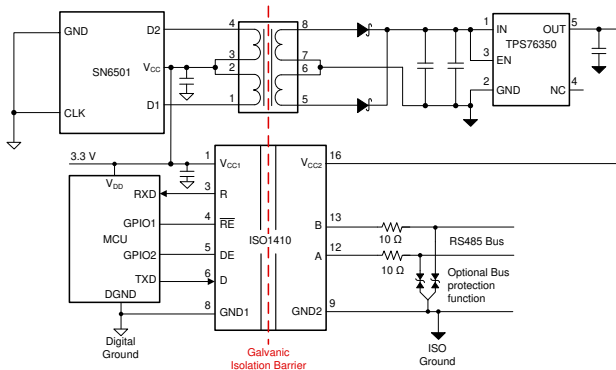

Figure 3. Isolated Signal and Power Solution for RS-485 using ISO1410 and SN6501 Transformer Driver

The alternative solution for isolated power is to use an isolated RS-485 transceiver with integrated DC/DC converter, such as ISOW1412 or ISOW1432. This family of devices provides a single chip solution that includes the functionality of an isolator, transceiver, and isolated DC/DC converter in a single 20-SOIC package. Figure 4 shows the complete solution for isolated signal and power using the ISOW1412.

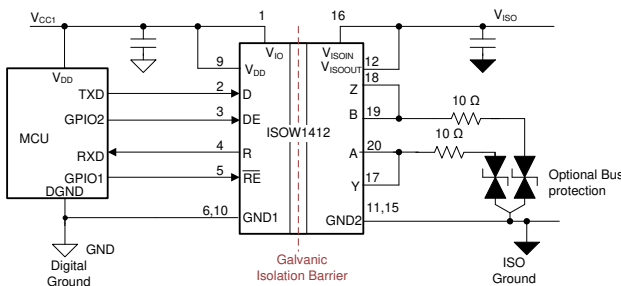

Figure 4. Isolated Signal and Power Solution for RS-485 using ISOW1412

The advantages of the ISOW14xx family is that it eliminates the need for a transformer on the board, reduces board size, and makes certifications easy with only a single isolated component. The small solution size comes with a trade off in efficiency as the transformer integrated into the chip provides a typical efficiency up to 47%. With the integrated power solution, since the transformer is smaller in size, switching frequencies are higher, leading to higher radiated emissions as compared to the discrete solution. While emissions will be higher than the SN650x solution, the ISOW14xx family's low-emission design ensures the capability of meeting CISPR 32 radiated emissions class B limit lines with just two ferrite beads on a two-layer PCB.

Conclusion

Choosing the right components for designing isolated RS-485 systems is critical. The selection of the discrete or integrated solutions depends on the trade-offs between size, ease of design versus efficiency, emissions. Discrete implementations of isolated power supplies provide higher efficiency and lower emissions while the integrated solution for isolated power provides a compact and simple solution for space critical applications.

Table 1. Relevant Technical Documents

Document
Enabling high voltage signal isolation quality and reliability
Robust Isolated RS-485 enables new industrial applications
How to isolate RS-485 for smallest size and highest reliability

IMPORTANT NOTICE AND DISCLAIMER

TI PROVIDES TECHNICAL AND RELIABILITY DATA (INCLUDING DATASHEETS), DESIGN RESOURCES (INCLUDING REFERENCE DESIGNS), APPLICATION OR OTHER DESIGN ADVICE, WEB TOOLS, SAFETY INFORMATION, AND OTHER RESOURCES "AS IS" AND WITH ALL FAULTS, AND DISCLAIMS ALL WARRANTIES, EXPRESS AND IMPLIED, INCLUDING WITHOUT LIMITATION ANY IMPLIED WARRANTIES OF MERCHANTABILITY, FITNESS FOR A PARTICULAR PURPOSE OR NON-INFRINGEMENT OF THIRD PARTY INTELLECTUAL PROPERTY RIGHTS.

These resources are intended for skilled developers designing with TI products. You are solely responsible for (1) selecting the appropriate TI products for your application, (2) designing, validating and testing your application, and (3) ensuring your application meets applicable standards, and any other safety, security, or other requirements. These resources are subject to change without notice. TI grants you permission to use these resources only for development of an application that uses the TI products described in the resource. Other reproduction and display of these resources is prohibited. No license is granted to any other TI intellectual property right or to any third party intellectual property right. TI disclaims responsibility for, and you will fully indemnify TI and its representatives against, any claims, damages, costs, losses, and liabilities arising out of your use of these resources.

TI's products are provided subject to TI's Terms of Sale (<https://www.ti.com/legal/termsofsale.html>) or other applicable terms available either on [ti.com](https://www.ti.com) or provided in conjunction with such TI products. TI's provision of these resources does not expand or otherwise alter TI's applicable warranties or warranty disclaimers for TI products.

Mailing Address: Texas Instruments, Post Office Box 655303, Dallas, Texas 75265
Copyright © 2021, Texas Instruments Incorporated