

TLV181x-Q1 and TLV182x-Q1 Family of 40V Automotive Rail-to-Rail Input Comparators with Push-Pull or Open-Drain Output Options

1 Features

- Qualified for automotive applications
- AEC-Q100 qualified with the following results:
 - Device temperature grade 1: -40°C to 125°C ambient operating temperature range
 - Device HBM ESD classification level 2
 - Device CDM ESD classification level C3
- Wide 2.4V to 40V supply range
- Low quiescent current $5\mu\text{A}$ per channel
- Rail-to-Rail input
- Power-On Reset (POR) for known start-up
- Low input offset voltage $500\mu\text{V}$
- 420ns typical propagation delay
- Push-pull output option (TLV181x-Q1)
- Open-drain output option (TLV182x-Q1)
- **Functional Safety-Capable**
 - [Documentation available to aid functional safety system design](#)

2 Applications

- [HEV/EV and power train](#)
- [Infotainment and cluster](#)
- [Body control module](#)

3 Description

The TLV181x-Q1 and TLV182x-Q1 are a family of Automotive grade 40 volt single, dual and quad channel comparators with multiple output options. The family offers rail-to-rail inputs with push-pull or open-drain output options. The family has an excellent speed-to-power combination with a propagation delay of 420ns with a full supply voltage range of 2.4V to 40V with a quiescent supply current of only $5\mu\text{A}$ per channel.

All devices include a Power-On Reset (POR) feature. This makes sure the output is in a known state until

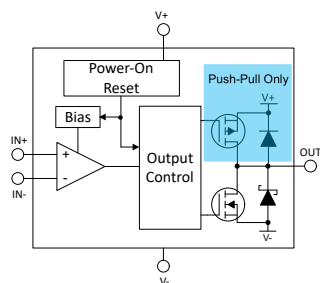

TLV18xx-Q1 Block Diagram

the minimum supply voltage has been reached before the output responds to the inputs, thus preventing false outputs during system power-up and power-down.

The TLV181x-Q1 comparators have a push-pull output stage capable of sinking and sourcing milliamps of current when controlling an LED or driving a capacitive load such as a MOSFET gate.

The TLV182x-Q1 comparators have an open-drain output stage that can be pulled up to 40V independent of comparator supply voltage.

Package Information

PART NUMBER	PACKAGE (1)	BODY SIZE (NOM) (2)
TLV1811-Q1, TLV1821-Q1 (Single)	SC-70 (5)	1.25mm × 2.00mm
	SOT-23 (5)	1.60mm × 2.90mm
TLV1811L-Q1, TLV1821L-Q1 (Single - alt pinout)	SOT-23 (5)	1.60mm × 2.90mm
	SOIC (8)	3.91mm × 4.90mm
TLV1812-Q1, TLV1822-Q1 (Dual)	TSSOP (8)	3.00mm × 4.40mm
	VSSOP (8)	3.00mm × 3.00mm
	WSON (8) (Preview)	2.00mm × 2.00mm
	SOT-23 (8)	1.60mm × 2.90mm
TLV1814-Q1, TLV1824-Q1 (Quad)	SOIC (14)	3.91mm × 8.65mm
	TSSOP (14)	4.40mm × 5.00mm
	SOT-23 (14)	4.20mm × 2.00mm
	WQFN (16)	3.00mm × 3.00mm

- (1) For all available packages, see the orderable addendum at the end of the data sheet.
- (2) The package size (length × width) is a nominal value and includes pins, where applicable.

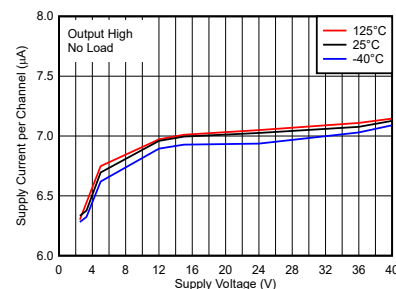

TLV18xx-Q1 Supply Current vs. Supply Voltage

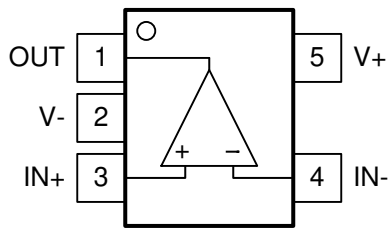

Table of Contents

1 Features	1	7.2 Functional Block Diagrams.....	13
2 Applications	1	7.3 Feature Description.....	13
3 Description	1	7.4 Device Functional Modes.....	13
4 Pin Configuration and Functions	3	8 Application and Implementation	16
Pin Functions:TLV18x1-Q1 TLV18x1L-Q1	3	8.1 Application Information.....	16
Pin Functions:TLV1812-Q1 and TLV1822-Q1	4	8.2 Typical Applications.....	19
Pin Functions: TLV1814-Q1 and TLV1824-Q1	5	8.3 Power Supply Recommendations.....	27
5 Specifications	6	8.4 Layout.....	27
5.1 Absolute Maximum Ratings.....	6	9 Device and Documentation Support	29
5.2 ESD Ratings.....	6	9.1 Documentation Support.....	29
5.3 Recommended Operating Conditions.....	6	9.2 Receiving Notification of Documentation Updates....	29
5.4 Thermal Information - Single.....	7	9.3 Support Resources.....	29
5.5 Thermal Information - Dual.....	7	9.4 Trademarks.....	29
5.6 Thermal Information - Quad.....	7	9.5 Electrostatic Discharge Caution.....	29
5.7 Electrical Characteristics.....	8	9.6 Glossary.....	29
5.8 Switching Characteristics.....	9	10 Revision History	30
6 Typical Characteristics	10	11 Mechanical, Packaging, and Orderable Information	30
7 Detailed Description	13		
7.1 Overview.....	13		

4 Pin Configuration and Functions

Pin Functions: TLV18x1-Q1 TLV18x1L-Q1



TLV18x1-Q1 TLV18x1L-Q1
Standard "North West" pinout
DBV, DCK Packages,
SOT-23-5, SC-70-5
Top View

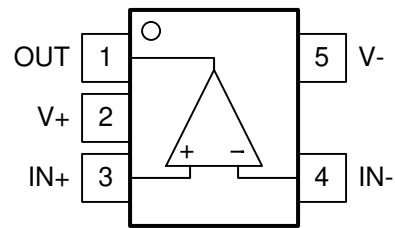

TLV1811L-Q1 and TLV1821L-Q1 DBV Package,
"LMC72x1/TLV72x1 type" pinout with reversed
supplies
SOT-23-5,
Top View

Table 4-1. Pin Functions: TLV1811-Q1, TLV1821-Q1, TLV1811L-Q1 and TLV1821L-Q1

NAME	TLV18x1-Q1		TLV18x1L-Q1	I/O	DESCRIPTION
	PINS		PINS		
	SOT-23	SC-70	SOT-23		
OUT	1	1	1	O	Output
V-	2	2	5	-	Negative Supply Voltage
IN+	3	3	3	I	Non-Inverting (+) Input
IN-	4	4	4	I	Inverting (-) Input
V+	5	5	2	-	Positive Supply Voltage

Pin Functions: TLV1812-Q1 and TLV1822-Q1

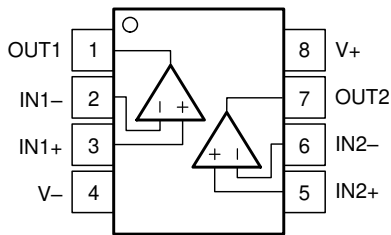

**D, DGK, PW, DDF Packages
 8-Pin SOIC, VSSOP, TSSOP, SOT-23-8
 Top View**

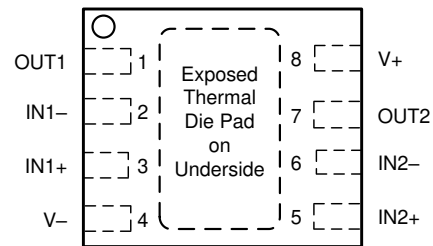

NOTE: Connect exposed thermal pad directly to V- pin.

**DSG Package,
 8-Pad WSON With Exposed Thermal Pad,
 Top View**

Table 4-2. Pin Functions: TLV1812-Q1 and TLV1822-Q1

PIN		I/O	DESCRIPTION
NAME	NO.		
OUT1	1	O	Output pin of the comparator 1
IN1-	2	I	Inverting input pin of comparator 1
IN1+	3	I	Noninverting input pin of comparator 1
V-	4	—	Negative (low) supply
IN2+	5	I	Noninverting input pin of comparator 2
IN2-	6	I	Inverting input pin of comparator 2
OUT2	7	O	Output pin of the comparator 2
V+	8	—	Positive supply
Thermal Pad	—	—	Connect directly to V- pin

Pin Functions: TLV1814-Q1 and TLV1824-Q1

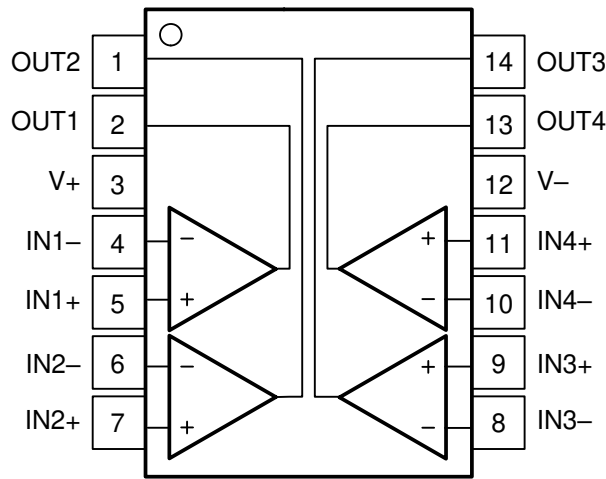

**D, PW, DYY Package,
14-Pin SOIC, TSSOP, SOT-23,
Top View**

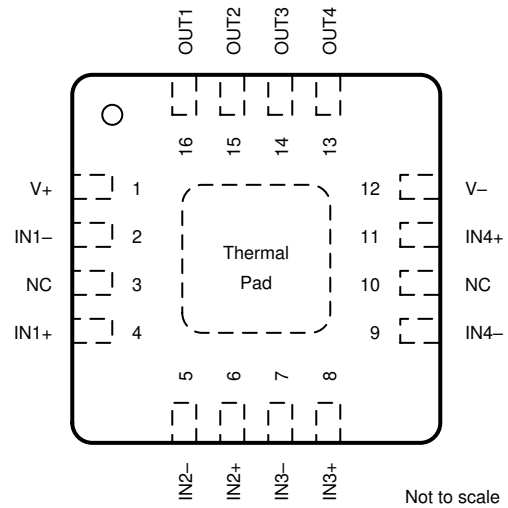

NOTE: Connect exposed thermal pad directly to V- pin.
NOTE: Wettable flank for devices with "W" in package suffix.

**RTE Package,
16-Pad WQFN With Exposed Thermal Pad,
Top View**

Table 4-3. Pin Functions: TLV1814-Q1 and TLV1824-Q1

NAME	PIN		I/O	DESCRIPTION
	SOIC	WQFN		
OUT2 ⁽¹⁾	1	15	O	Output pin of the comparator 2
OUT1 ⁽¹⁾	2	16	O	Output pin of the comparator 1
V+	3	1	—	Positive supply
IN1-	4	2	I	Negative input pin of the comparator 1
IN1+	5	4	I	Positive input pin of the comparator 1
IN2-	6	5	I	Negative input pin of the comparator 2
IN2+	7	6	I	Positive input pin of the comparator 2
IN3-	8	7	I	Negative input pin of the comparator 3
IN3+	9	8	I	Positive input pin of the comparator 3
IN4-	10	9	I	Negative input pin of the comparator 4
IN4+	11	11	I	Positive input pin of the comparator 4
V-	12	12	—	Negative supply
OUT4	13	13	O	Output pin of the comparator 4
OUT3	14	14	O	Output pin of the comparator 3
NC	—	3	—	No Internal Connection - Leave floating or GND
NC	—	10	—	No Internal Connection - Leave floating or GND
Thermal Pad	—	PAD	—	Connect directly to V- pin.

(1) Some manufacturers transpose the names of channels 1 and 2. Electrically the pinouts are identical, just a difference in channel naming convention.

5 Specifications

5.1 Absolute Maximum Ratings

over operating free-air temperature range (unless otherwise noted)⁽¹⁾

	MIN	MAX	UNIT
Supply voltage: $V_S = (V+) - (V-)$	-0.3	42	V
Input pins (IN+, IN-) from (V-) ⁽²⁾	-0.3	(V+) + 0.3	V
Current into Input pins (IN+, IN-)	-10	10	mA
Output (OUT) voltage (Open-Drain) from (V-) ⁽³⁾	-0.3	42	V
Output (OUT) voltage (Push-Pull) from (V-)	-0.3	(V+) + 0.3	V
Output (OUT) current ^{(4) (5) (6)}	-10	10	mA
Junction temperature, T_J		150	°C
Storage temperature, T_{stg}	-65	150	°C

- (1) Operation outside the Absolute Maximum Ratings can cause permanent device damage. Absolute Maximum Ratings do not imply functional operation of the device at these or any other conditions beyond those listed under Recommended Operating Conditions. If used outside the Recommended Operating Conditions but within the Absolute Maximum Ratings, the device may not be fully functional, and this may affect device reliability, functionality, performance, and shorten the device lifetime.
- (2) Input terminals are diode-clamped to (V-). Input signals that can swing more than 0.3V beyond the supply rails must be current-limited to 10mA or less.
- (3) Output (OUT) for open drain can be greater than (V+) and inputs (IN+, IN-) as long as within the -0.3V to 42V range
- (4) The output is diode-clamped to (V-) for both output options, and diode clamped to (V+) for the push-pull output option. The open drain version does not have a clamp to V+. Please see the *Outputs* and *ESD Protection* section of the *Application Information* Section for more information.
- (5) Output sinking and sourcing current is internally limited to <35mA when operating within the Absolute Maximum output voltage limits. The Absolute Maximum Output Current limit specified here is the maximum current through the clamp structure when exceeding the supply voltage below (V-) for both output options, or above (V+) for the push-pull option.
- (6) Short-circuit from output to (V-) or (V+). Continuous output short circuits at elevated supply voltages can result in excessive heating and exceeding the maximum allowed junction temperature, leading to eventual device destruction.

5.2 ESD Ratings

			VALUE	UNIT
$V_{(ESD)}$	Electrostatic discharge	Human-body model (HBM), per AEC Q100-002 ⁽¹⁾	±2000	V
		Charged-device model (CDM), per AEC Q100-0111	±1000	
		Charged-device model (CDM), per AEC Q100-0111, TLV1822-Q1 Only	±500	

- (1) AEC Q100-002 indicates that HBM stressing shall be in accordance with the ANSI/ESDA/JEDEC JS-001 specification.

5.3 Recommended Operating Conditions

over operating free-air temperature range (unless otherwise noted)

		MIN	MAX	UNIT
Supply voltage: $V_S = (V+) - (V-)$		2.4	40	V
Input voltage range from (V-)		-0.2	(V+) + 0.2	V
Output voltage range from (V-)	Open Drain	-0.2	40	V
Output voltage range from (V-)	Push Pull	-0.2	(V+) + 0.2	V
Ambient temperature, T_A		-40	125	°C

5.4 Thermal Information - Single

THERMAL METRIC ⁽¹⁾		TLV18x1-Q1		UNIT
		DCK (SC-70)	DBV (SOT-23)	
		5 PINS	5 PINS	
R _{θJA}	Junction-to-ambient thermal resistance	226.0	203.4	°C/W
R _{θJC(top)}	Junction-to-case (top) thermal resistance	129.5	105.4	°C/W
R _{θJB}	Junction-to-board thermal resistance	78.6	106.6	°C/W
Ψ _{JT}	Junction-to-top characterization parameter	51.5	54.0	°C/W
Ψ _{JB}	Junction-to-board characterization parameter	78.3	106.0	°C/W
R _{θJC(bot)}	Junction-to-case (bottom) thermal resistance	–	–	°C/W

(1) For more information about traditional and new thermal metrics, see the [Semiconductor and IC Package Thermal Metrics](#) application note.

5.5 Thermal Information - Dual

THERMAL METRIC ⁽¹⁾		TLV18x2-Q1					UNIT
		D (SOIC)	PW (TSSOP)	DDF (SOT-23)	DSG (WSON)	DGK (VSSOP)	
		8 PINS	8 PINS	8 PINS	8 PINS	8 PINS	
R _{θJA}	Junction-to-ambient thermal resistance	136.1	187.5	170.4	79.9	178.3	°C/W
R _{θJC(top)}	Junction-to-case (top) thermal resistance	76.8	76.7	90.3	100.1	66.4	°C/W
R _{θJB}	Junction-to-board thermal resistance	79.7	118.1	88.1	46.4	100.0	°C/W
Ψ _{JT}	Junction-to-top characterization parameter	26.8	14.4	7.5	5.3	9.2	°C/W
Ψ _{JB}	Junction-to-board characterization parameter	78.9	116.4	87.6	46.4	98.3	°C/W
R _{θJC(bot)}	Junction-to-case (bottom) thermal resistance	–	–	–	21.6	–	°C/W

(1) For more information about traditional and new thermal metrics, see the [Semiconductor and IC Package Thermal Metrics](#) application note.

5.6 Thermal Information - Quad

THERMAL METRIC ⁽¹⁾		TLV18x4-Q1				UNIT
		D (SOIC)	PW (TSSOP)	DYY (SOT-23- THN)	RTE (WQFN)	
		16 PINS	16 PINS	16 PINS	16 PINS	
R _{θJA}	Junction-to-ambient thermal resistance	104.2	124.1	119.9	53.8	°C/W
R _{θJC(top)}	Junction-to-case (top) thermal resistance	60.3	52.4	60.6	58.6	°C/W
R _{θJB}	Junction-to-board thermal resistance	60.2	67.2	79.0	29.0	°C/W
Ψ _{JT}	Junction-to-top characterization parameter	20.7	7.5	3.3	2.2	°C/W
Ψ _{JB}	Junction-to-board characterization parameter	59.8	66.6	41.2	28.9	°C/W
R _{θJC(bot)}	Junction-to-case (bottom) thermal resistance	–	–	–	13.1	°C/W

(1) For more information about traditional and new thermal metrics, see the [Semiconductor and IC Package Thermal Metrics](#) application note.

5.7 Electrical Characteristics

For V_S (Total Supply Voltage) = $(V+) - (V-) = 12V$, $V_{CM} = V_S / 2$ at $T_A = 25^\circ C$ (Unless otherwise noted)

PARAMETER		TEST CONDITIONS	MIN	TYP	MAX	UNIT
OFFSET VOLTAGE						
V_{OS}	Input offset voltage		-3	±0.5	3	mV
V_{OS}	Input offset voltage	$T_A = -40^\circ C$ to $+125^\circ C$	-4		4	mV
dV_{IO}/dT	Input offset voltage drift	$T_A = -40^\circ C$ to $+125^\circ C$		±1.2		$\mu V/^\circ C$
PSRR	Power supply rejection ratio	$V_S = 2.4V$ to $40V$, $V_{CM} = (V-)$		100		dB
POWER SUPPLY						
I_Q	Quiescent current, No Load	Output Low, $T_A = 25^\circ C$ TLV1811-Q1 Only		6	7.5	μA
		Output Low, $T_A = -40^\circ C$ to $+125^\circ C$ TLV1811-Q1 Only			8.5	
		Output High, $T_A = 25^\circ C$ TLV1811-Q1 Only		8	10	
		Output High, $T_A = -40^\circ C$ to $+125^\circ C$ TLV1811-Q1 Only			11	
I_Q	Quiescent current per comparator, No Load	Output Low, $T_A = 25^\circ C$		6	7.5	μA
		Output Low, $T_A = -40^\circ C$ to $+125^\circ C$			8.5	
		Output High, $T_A = 25^\circ C$		7	9	
		Output High, $T_A = -40^\circ C$ to $+125^\circ C$			10	
V_{POR}	Power On Reset Voltage			1.7		V
INPUT BIAS CURRENT						
I_B	Input bias current			150		fA
I_B	Input bias current	$T_A = -40^\circ C$ to $+125^\circ C$	-1.2		1.2	nA
I_{OS}	Input offset current			10		fA
INPUT CAPACITANCE						
C_{ID}	Input Capacitance, Differential			2		pF
C_{IC}	Input Capacitance, Common Mode			8		pF
INPUT COMMON MODE RANGE						
$V_{CM-Range}$	Common-mode voltage range	$V_S = 2.4V$ to $40V$ $T_A = -40^\circ C$ to $+125^\circ C$	$(V-) - 0.2$		$(V+) + 0.2$	V
OUTPUT						
V_{OL}	Voltage swing from $(V-)$	$I_{SINK} = 4mA$ $T_A = -40^\circ C$ to $+125^\circ C$			250	mV
V_{OH}	Voltage swing from $(V+)$ (for Push-Pull only)	$I_{SOURCE} = 4mA$ $T_A = -40^\circ C$ to $+125^\circ C$			250	mV
I_{LKG}	Open-drain output leakage current	$V_{ID} = +0.1V$, $V_{PULLUP} = (V+)$ $T_A = -40^\circ C$ to $+125^\circ C$		0.1		nA
I_{OL}	Short-circuit current	Sinking	15	30		mA
I_{OH}	Short-circuit current	Sourcing (for Push-Pull only)	15	30		mA

5.8 Switching Characteristics

For V_S (Total Supply Voltage) = $(V+) - (V-)$ = 12V, $V_{CM} = V_S / 2$ at $T_A = 25^\circ\text{C}$ (Unless otherwise noted)

PARAMETER		TEST CONDITIONS	MIN	TYP	MAX	UNIT
OUTPUT						
T_{PD-HL}	Propagation delay time, high-to-low	$V_{OD} = 10\text{mV}$, $C_L = 50\text{pF}$		900		ns
T_{PD-HL}	Propagation delay time, high-to-low	$V_{OD} = 100\text{mV}$, $C_L = 50\text{pF}$		450		ns
T_{PD-LH}	Propagation delay time, low-to-high, push-pull output	$V_{OD} = 10\text{mV}$, $C_L = 50\text{pF}$		900		ns
T_{PD-LH}	Propagation delay time, low-to-high, push-pull output	$V_{OD} = 100\text{mV}$, $C_L = 50\text{pF}$		420		ns
T_{RISE}	Output Rise Time, 20% to 80%, push-pull output	$C_L = 50\text{pF}$		15		ns
T_{FALL}	Output Fall Time, 80% to 20%	$C_L = 50\text{pF}$		15		ns
F_{TOGGLE}	Toggle Frequency	$V_{ID} = 100\text{mV}$, $C_L = 50\text{pF}$		500		kHz
POWER ON TIME						
P_{ON}	Power on-time			200		μs

6 Typical Characteristics

$T_A = 25^\circ\text{C}$, $V_S = 12\text{V}$, $R_{\text{PULLUP}} = 2.5\text{k}$, $C_L = 20\text{pF}$, $V_{\text{CM}} = 0\text{V}$, $V_{\text{UNDERDRIVE}} = 100\text{mV}$, $V_{\text{OVERDRIVE}} = 100\text{mV}$ unless otherwise noted.

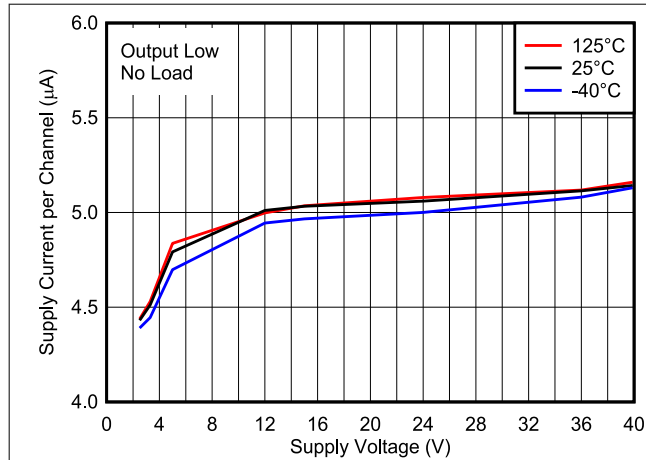

Figure 6-1. Supply Current per Channel vs. Supply Voltage, Output Low

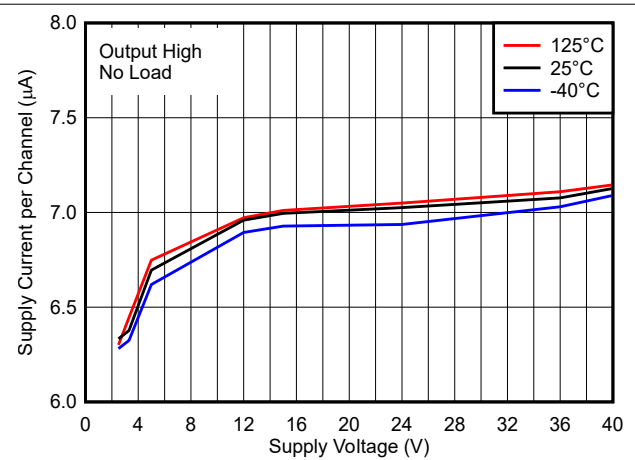

Figure 6-2. Supply Current per Channel vs. Supply Voltage, Output High

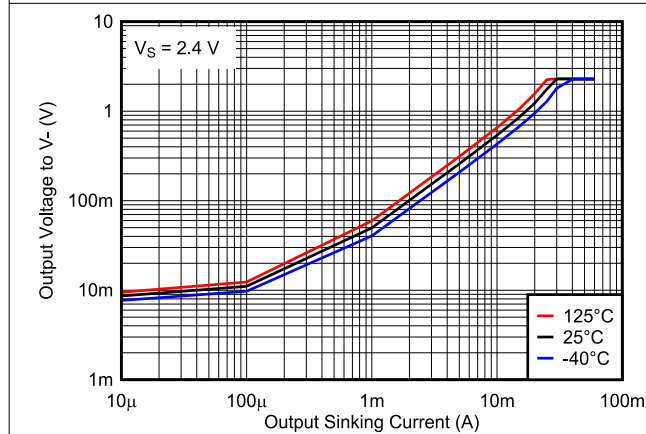

Figure 6-3. Output Voltage vs. Output Sinking Current, 2.4V

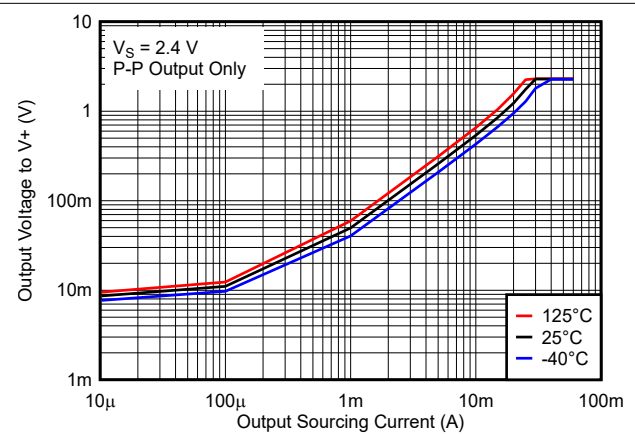

Figure 6-4. Output Voltage vs. Output Sourcing Current, 2.4V

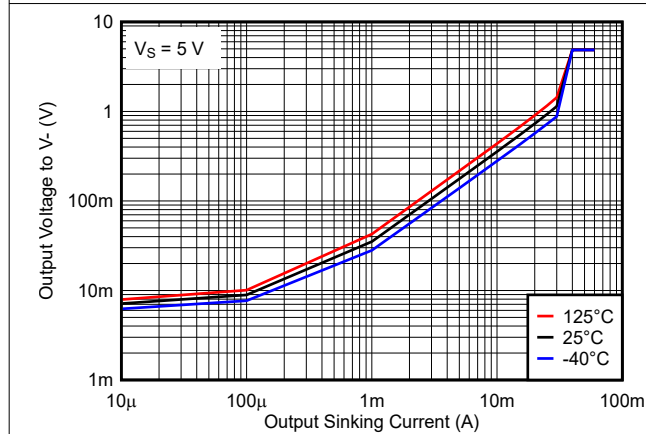

Figure 6-5. Output Voltage vs. Output Sinking Current, 5V

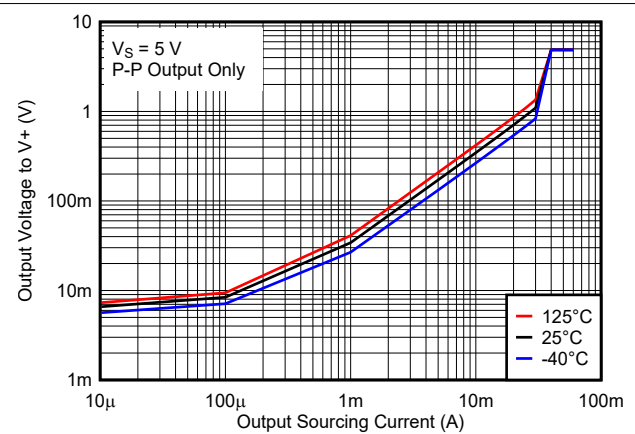

Figure 6-6. Output Voltage vs. Output Sourcing Current, 5V

6 Typical Characteristics (continued)

$T_A = 25^\circ\text{C}$, $V_S = 12\text{V}$, $R_{\text{PULLUP}} = 2.5\text{k}$, $C_L = 20\text{pF}$, $V_{\text{CM}} = 0\text{V}$, $V_{\text{UNDERDRIVE}} = 100\text{mV}$, $V_{\text{OVERDRIVE}} = 100\text{mV}$ unless otherwise noted.

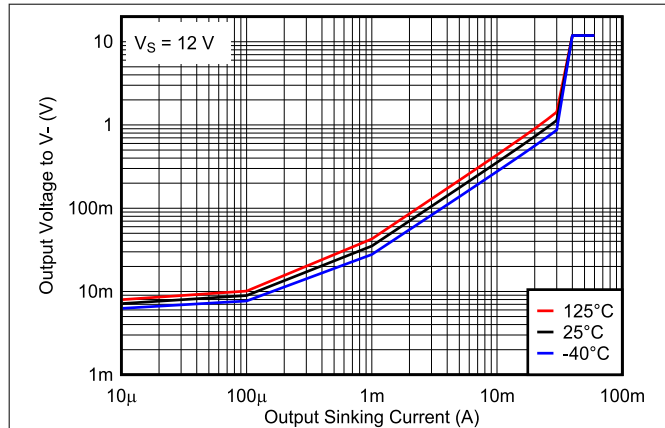

Figure 6-7. Output Voltage vs. Output Sinking Current, 12V

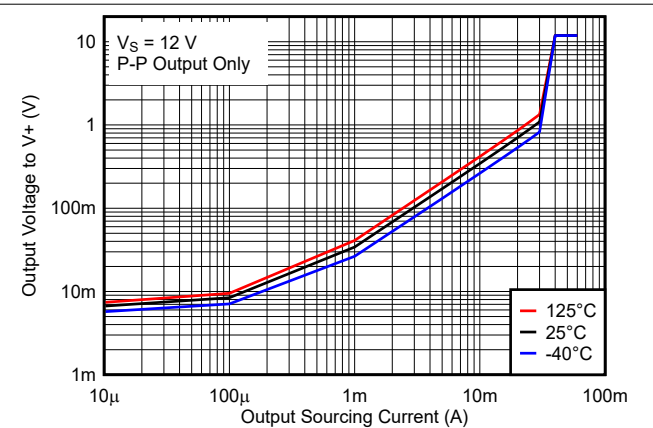

Figure 6-8. Output Voltage vs. Output Sourcing Current, 12V

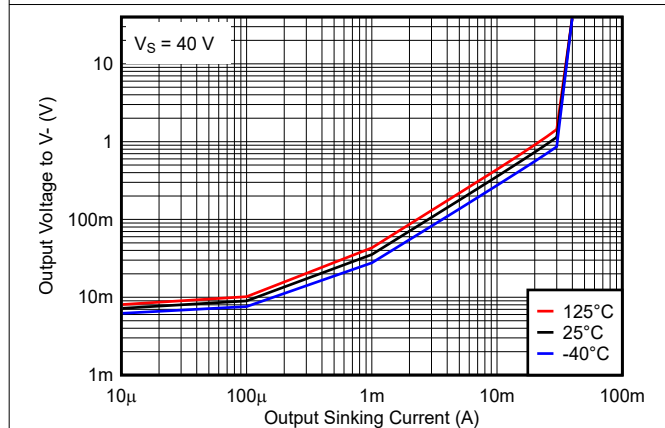

Figure 6-9. Output Voltage vs. Output Sinking Current, 40V

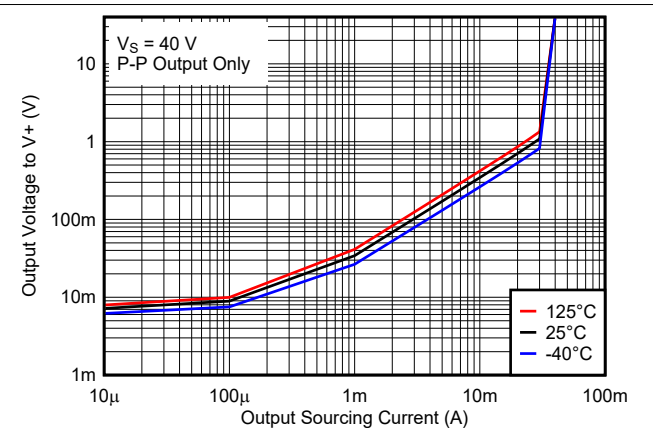

Figure 6-10. Output Voltage vs. Output Sourcing Current, 40V

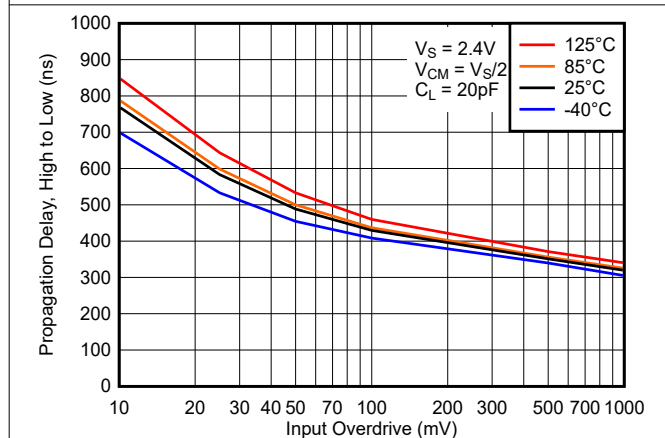

Figure 6-11. Propagation Delay, High to Low, 2.4V

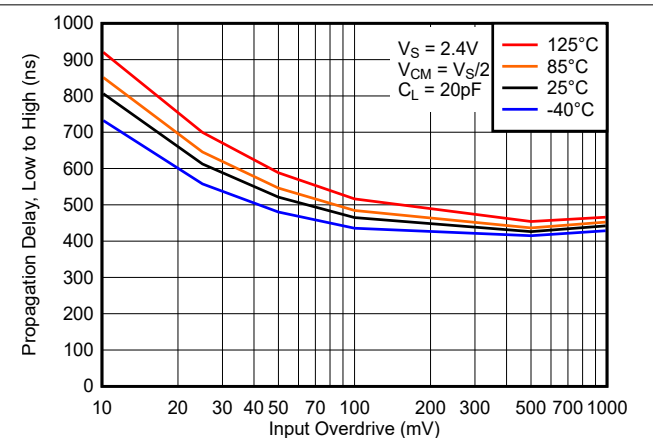

Figure 6-12. Propagation Delay, Low to High, 2.4V

6 Typical Characteristics (continued)

$T_A = 25^\circ\text{C}$, $V_S = 12\text{V}$, $R_{\text{PULLUP}} = 2.5\text{k}$, $C_L = 20\text{pF}$, $V_{\text{CM}} = 0\text{V}$, $V_{\text{UNDERDRIVE}} = 100\text{mV}$, $V_{\text{OVERDRIVE}} = 100\text{mV}$ unless otherwise noted.

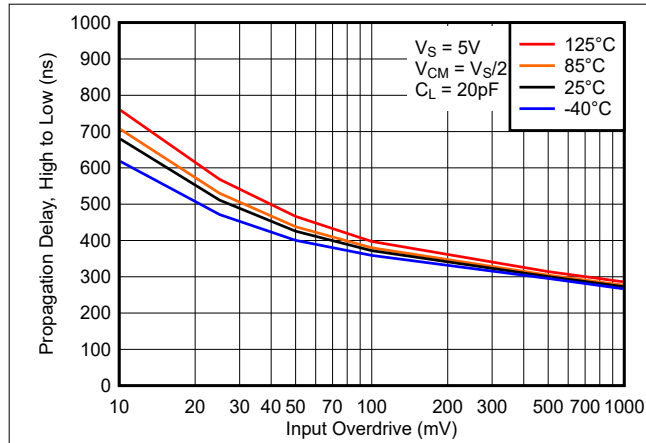

Figure 6-13. Propagation Delay, High to Low, 5V

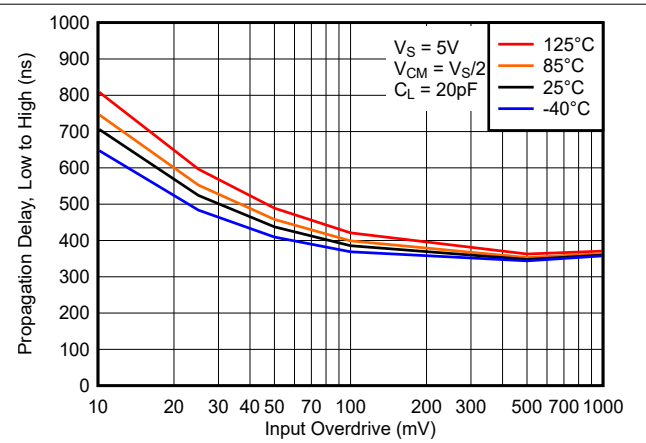

Figure 6-14. Propagation Delay, Low to High, 5V

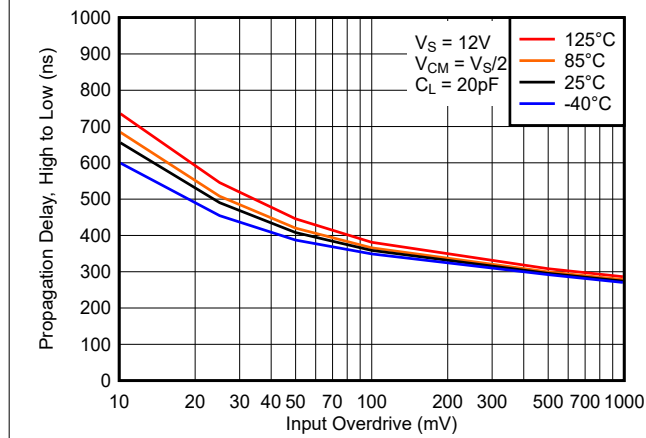

Figure 6-15. Propagation Delay, High to Low, 12V

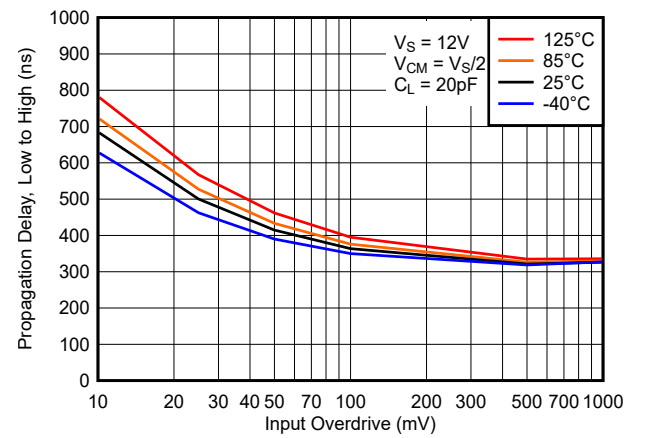

Figure 6-16. Propagation Delay, Low to High, 12V

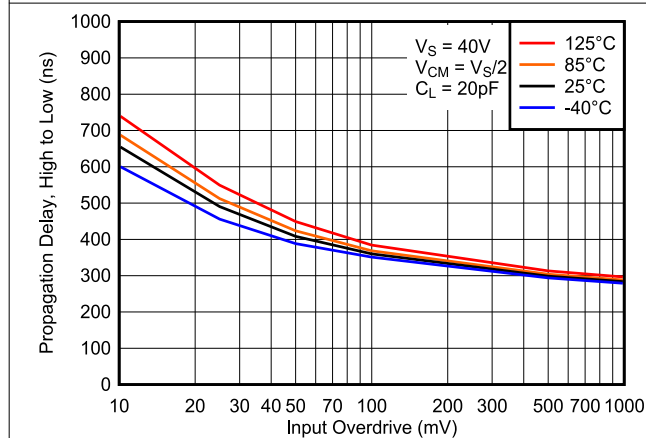

Figure 6-17. Propagation Delay, High to Low, 40V

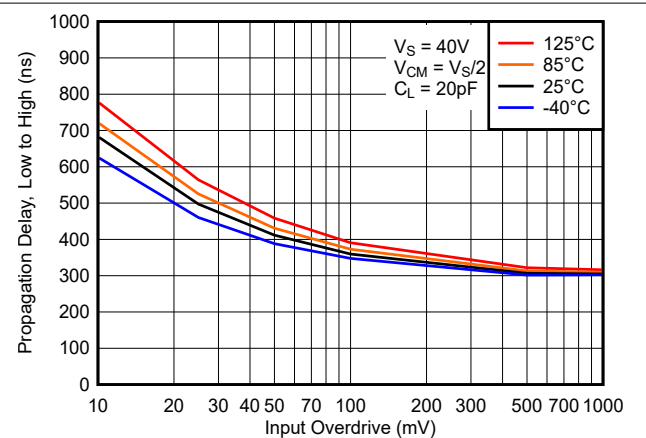

Figure 6-18. Propagation Delay, Low to High, 40V

7 Detailed Description

7.1 Overview

The TLV181x-Q1 and TLV182x-Q1 devices are micro-power comparators with push-pull and open-drain output options. Operating down to 2.4V while only consuming only 5µA per channel, the TLV181x-Q1 and TLV182x-Q1 are well suited for portable, automotive and industrial applications. An internal power-on reset circuit is designed so that the output remains in a known state during power-up and power-down.

7.2 Functional Block Diagrams

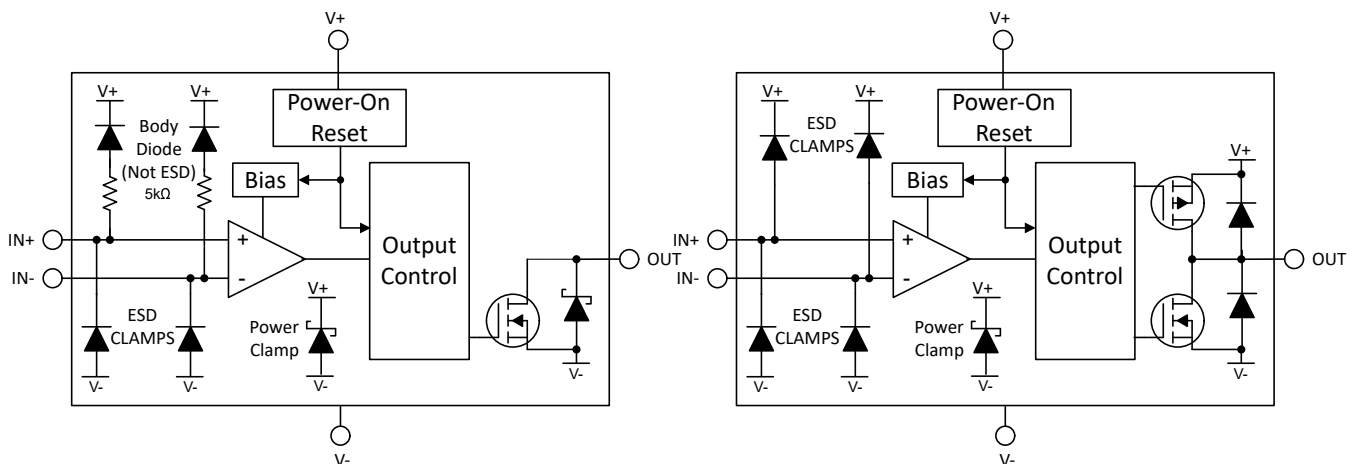

Figure 7-1. TLV182x-Q1 Open-Drain Block Diagram

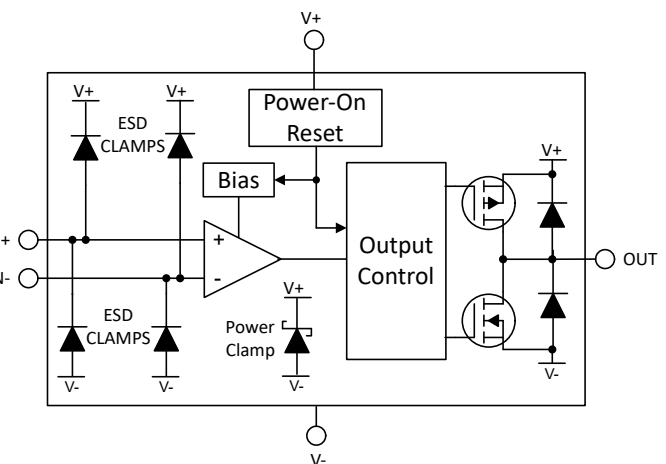

Figure 7-2. TLV181x-Q1 Push-Pull Block Diagram

7.3 Feature Description

TLV18xx Family Options

The TLV18xyy family consists of several output and pinout options, all featuring 40V operation, micro-power 5µA supply currents, 420ns propagation delay, and a Power-On Reset (POR) function.

The TLV18xx family has two output options:

The TLV181x-Q1 has a **push-pull** (sink-source) output.

The TLV182x-Q1 has a **open-drain** (sink only) output, capable of being pulled-up to any voltage up to 40V, independent of comparator supply voltage.

The TLV1811L-Q1 and TLV1821L-Q1 are alternate pinouts of the TLV1811-Q1 and TLV1821-Q1 that allow upgrading older devices such as the TLV7211, TLV7221, LMC7211 and LMC7221 family.

7.4 Device Functional Modes

7.4.1 Inputs

7.4.1.1 TLV18xx Rail-to-Rail Input

The TLV18xx-Q1 input voltage range extends from 200mV below V- to 200mV above V+. The differential input voltage (V_{ID}) can be any voltage within these limits. No phase-inversion of the comparator output occurs when the input voltages stay within the specified range.

The Rail-to-Rail input does have an ESD clamp to the V+ supply line and therefore the input voltage must not exceed the supply voltages by more than 200mV. TI does not recommend applying signals to the rail to rail inputs with no supply voltage.

7.4.1.2 ESD Protection

The TLV182x open-drain option ESD protection consists of a snapback ESD clamp between the output and V- to allow the output to be pulled above V+ to a maximum of 40V. For the inputs, there is a "lower" ESD clamp between V- and the inputs and there is also a parasitic "upper" ESD soft-clamp diode between the input and V+ with a 5k Ω equivalent resistance (as shown in [Figure 7-1](#)). These are not traditional ESD cells and current must be limited to 1mA or less across the this upper diode junction and resistance. External diode clamping is recommended if the input voltage can exceed V+ during operation.

The TLV181x push-pull inputs and output ESD protection contains a conventional diode-type "upper" ESD clamp between the I/O pins and V+, and a "lower" ESD clamp between the I/O pins and V-. The inputs or output must not exceed the supply rails by more than 200mV.

If the inputs are to be connected to a low impedance source, such as a power supply or buffered reference line, TI recommends adding a current-limiting resistor in series with the input to limit any currents when the clamps conduct. The current must be limited 10mA or less, though TI recommends limiting the current to 1mA or less. This series resistance can be part of any resistive input dividers or networks.

7.4.1.3 Unused Inputs

If a channel is not to be used, DO NOT tie the inputs together. Due to the high equivalent bandwidth and low offset voltage, tying the inputs directly together can cause high frequency chatter as the device triggers on it's own internal wideband noise. Instead, the inputs must be tied to any available voltage that resides within the specified input voltage range and provides a minimum of 50mV differential voltage. For example, one input can be grounded and the other input connected to a reference voltage, or even V+ (as long as the input is directly connected to the V+ pin to avoid transients).

7.4.2 Outputs

7.4.2.1 TLV181x-Q1 Push-Pull Output

The TLV181x-Q1 features a push-pull output stage capable of both sinking and sourcing current. This allows driving loads such as LED's and MOSFET gates, as well as eliminating the need for a power-wasting external pull-up resistor. The push-pull output must never be connected to another output.

Directly shorting the output to the opposite supply rail (V+ when output "low" or V- when output "High") can result in thermal runaway and eventual device destruction at high (>12V) supply voltages. If output shorts are possible, a series current limiting resistor is recommended to limit the power dissipation.

Unused push-pull outputs must be left floating, and never tied to a supply, ground, or another output.

7.4.2.2 TLV182x-Q1 Open-Drain Output

The TLV182x-Q1 features an open-drain (also commonly called open collector) sinking-only output stage enabling the output logic levels to be pulled up to an external voltage from 0V up to 40V, independent of the comparator supply voltage (V+). The open-drain output allows logical OR'ing of multiple open drain outputs and logic level translation. TI recommends setting the pull-up resistor current to between 100uA and 1mA. Lower value pull-up resistor values can help increase the rising edge rise-time, but at the expense of increasing V_{OL} and higher power dissipation. The rise-time is dependent on the time constant of the total pull-up resistance and total load capacitance. Large value pull-up resistors (>1 M Ω) creates an exponential rising edge due to the output RC time constant and increase the rise-time.

Directly shorting the output to V+ can result in thermal runaway and eventual device destruction at high (>12V) pull-up voltages. If output shorts are possible, a series current limiting resistor is recommended to limit the power dissipation.

Unused open drain outputs can be left floating, or can be tied to the V- pin if floating pins are not desired.

7.4.3 Power-On Reset (POR)

The TLV18xx -Q1 family has an internal Power-on-Reset (POR) circuit for known start-up or power-down conditions. While the power supply (V_+) is ramping up or ramping down, the POR circuitry is activated for up to $200\mu\text{s}$ after the minimum supply voltage threshold of 2.4V is crossed, or immediately when the supply voltage drops below 2.4V . When the supply voltage is equal to or greater than the minimum supply voltage, and after the delay period, the comparator output reflects the state of the differential input (V_{ID}).

For the TLV181x-Q1 push-pull output devices, the output is held low during the POR period (t_{on}).

For the TLV182x-Q1 open drain output option the POR circuit keeps the output high impedance (Hi-Z) during the POR period (t_{on}).

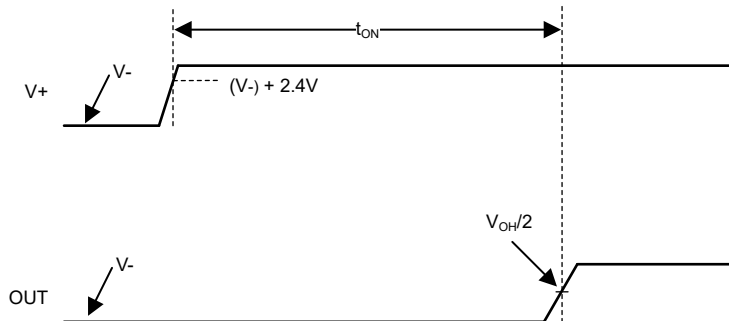

Figure 7-3. Power-On Reset Timing Diagram

Note: The output voltage rises with the pull-up voltage during the POR period.

7.4.4 Hysteresis

The TLV18xx-Q1 family does not have internal hysteresis. Due to the wide effective bandwidth and low input offset voltage, there is a possibility for the output to "chatter" when the absolute differential voltage is near zero as the comparator triggers on internal wideband noise. This is normal comparator behavior and is expected. TI recommends that the user add external hysteresis if slow moving signals are expected. See [Section 8.1.2](#) in the following section.

8 Application and Implementation

Note

Information in the following applications sections is not part of the TI component specification, and TI does not warrant its accuracy or completeness. TI's customers are responsible for determining suitability of components for their purposes. Customers should validate and test their design implementation to confirm system functionality.

8.1 Application Information

8.1.1 Basic Comparator Definitions

8.1.1.1 Operation

The basic comparator compares the input voltage (V_{IN}) on one input to a reference voltage (V_{REF}) on the other input. In the [Figure 8-1](#) example below, if V_{IN} is less than V_{REF} , the output voltage (V_O) is logic low (V_{OL}). If V_{IN} is greater than V_{REF} , the output voltage (V_O) is at logic high (V_{OH}). [Table 8-1](#) summarizes the output conditions. The output logic can be inverted by simply swapping the input pins.

Table 8-1. Output Conditions

Inputs Condition	Output
$IN+ > IN-$	HIGH (V_{OH})
$IN+ = IN-$	Indeterminate (chatters - see Section 8.1.2)
$IN+ < IN-$	LOW (V_{OL})

8.1.1.2 Propagation Delay

There is a delay between from when the input crosses the reference voltage and the output responds. This is called the Propagation Delay. Propagation delay can be different between high-to low and low-to-high input transitions. This is shown as t_{pLH} and t_{pHL} in the Comparator Timing Diagram and is measured from the mid-point of the input to the midpoint of the output. Likewise, propagation varies with what is called overdrive (V_{OD}) and underdrive (V_{UD}) voltage levels (see Overdrive and Underdrive Voltage).

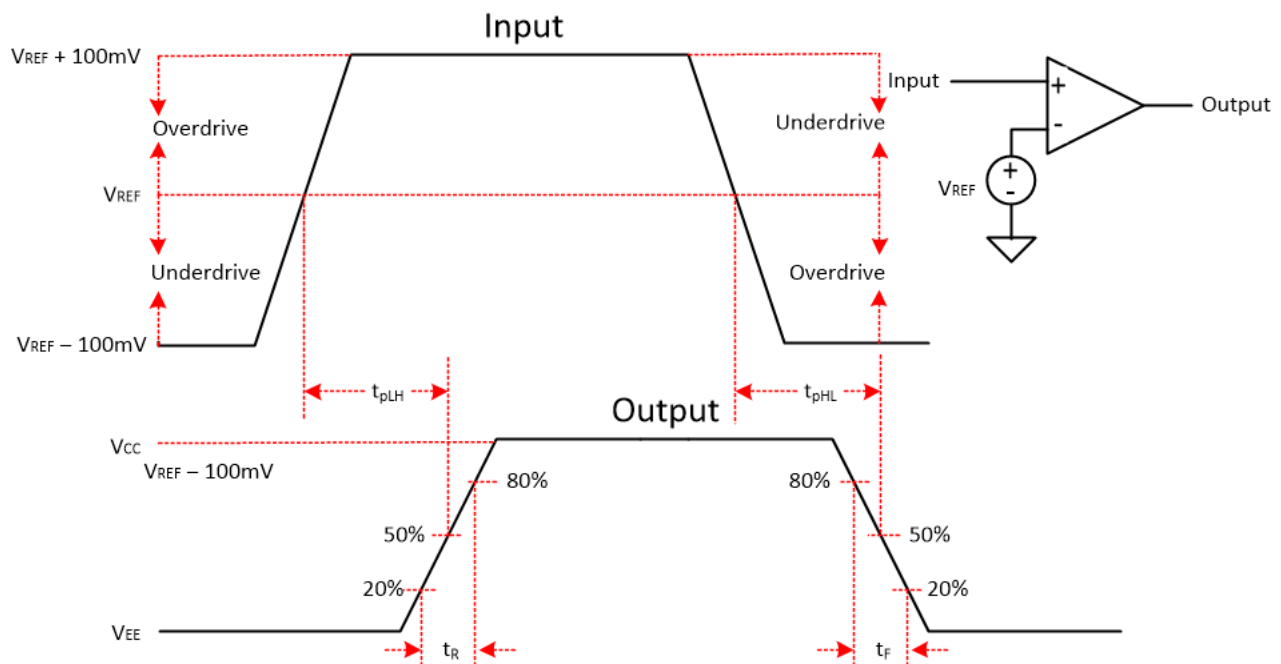

Figure 8-1. Comparator Timing Diagram

8.1.1.3 Overdrive and Underdrive Voltage

The overdrive voltage, V_{OD} , is the amount of input voltage beyond the reference voltage (and not the total input peak-to-peak voltage). The overdrive voltage is 100mV as shown in the [Figure 8-1](#) example. Similarly, underdrive voltage, V_{UD} , is how far below REF the input starts. The overdrive and underdrive voltages influence the propagation delay (t_p). See curves in the Typical Characteristics section for more details. The smaller the overdrive voltage, the longer the propagation delay, particularly when <100mV. If the fastest speeds are desired, apply the highest amount of overdrive possible. Contrary to overdrive voltage, larger underdrive voltage causes t_p to increase. This is particularly important in applications where rail-to-rail input swings are present at the comparator inputs. The result can be skewed propagation delay (difference between t_{pLH} and t_{pHL}). As a low power comparator, TI does not recommend using this comparator family if variation in propagation delay is critical.

The risetime (t_r) and falltime (t_f) is the time from the 20% and 80% points of the output waveform.

8.1.2 Hysteresis

The basic comparator configuration can oscillate or produce a noisy "chatter" output if the applied differential input voltage is near the comparator's offset voltage. This typically occurs when the input signal is moving very slowly across the switching threshold of the comparator.

This problem can be prevented by the addition of hysteresis or positive feedback.

The hysteresis transfer curve is shown in [Figure 8-2](#). This curve is a function of three components: V_{TH} , V_{OS} , and V_{HYST} :

- V_{TH} is the actual set voltage or threshold trip voltage.
- V_{OS} is the internal offset voltage between V_{IN+} and V_{IN-} . This voltage is added to V_{TH} to form the actual trip point at which the comparator must respond to change output states.
- V_{HYST} is the hysteresis (or trip window) that is designed to reduce comparator sensitivity to noise.

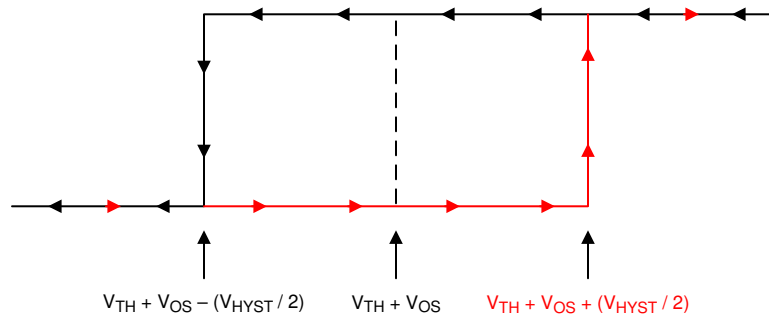

Figure 8-2. Hysteresis Transfer Curve

For more information, please see the [Comparator with and without hysteresis circuit](#) application note.

8.1.2.1 Inverting Comparator With Hysteresis

The inverting comparator with hysteresis requires a three-resistor network that is referenced to the comparator supply voltage (V_{CC}), as shown in [Figure 8-3](#).

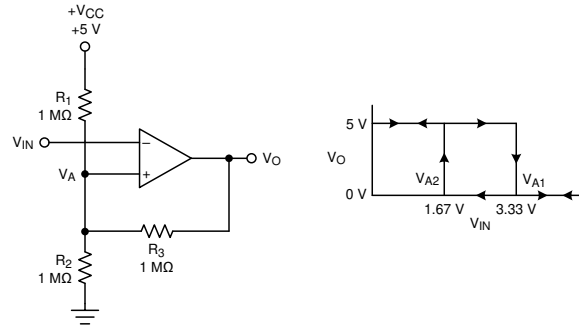

Figure 8-3. TLV181x-Q1 in an Inverting Configuration With Hysteresis

The equivalent resistor networks when the output is high and low are shown in [Figure 8-3](#).

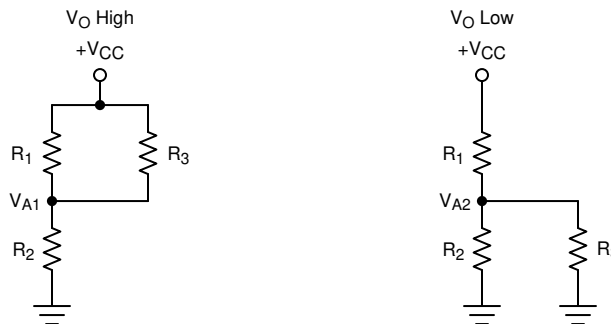

Figure 8-4. Inverting Configuration Resistor Equivalent Networks

When V_{IN} is less than V_A , the output voltage is high (for simplicity, assume V_O switches as high as V_{CC}). The three network resistors can be represented as $R1 \parallel R3$ in series with $R2$, as shown in [Figure 8-4](#).

[Equation 1](#) below defines the high-to-low trip voltage (V_{A1}).

$$V_{A1} = V_{CC} \times \frac{R2}{(R1 \parallel R3) + R2} \quad (1)$$

When V_{IN} is greater than V_A , the output voltage is low. In this case, the three network resistors can be presented as $R2 \parallel R3$ in series with $R1$, as shown in [Equation 2](#).

Use [Equation 2](#) to define the low to high trip voltage (V_{A2}).

$$V_{A2} = V_{CC} \times \frac{R2 \parallel R3}{R1 + (R2 \parallel R3)} \quad (2)$$

[Equation 3](#) defines the total hysteresis provided by the network.

$$\Delta V_A = V_{A1} - V_{A2} \quad (3)$$

8.1.2.2 Non-Inverting Comparator With Hysteresis

A non-inverting comparator with hysteresis requires a two-resistor network and a voltage reference (V_{REF}) at the inverting input, as shown in [Figure 8-5](#),

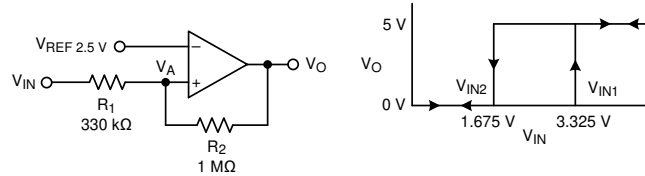

Figure 8-5. TLV181x-Q1 in a Non-Inverting Configuration With Hysteresis

The equivalent resistor networks when the output is high and low are shown in [Figure 8-6](#).

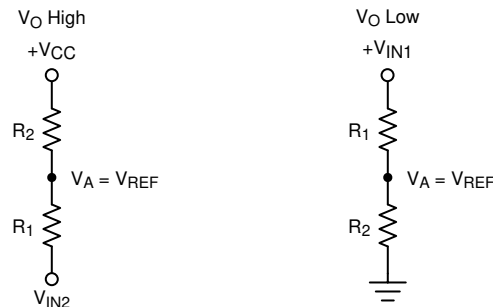

Figure 8-6. Non-Inverting Configuration Resistor Networks

When V_{IN} is less than V_{REF} , the output is low. For the output to switch from low to high, V_{IN} must rise above the V_{IN1} threshold. Use [Equation 4](#) to calculate V_{IN1} .

$$V_{IN1} = R1 \times \frac{V_{REF}}{R2} + V_{REF} \quad (4)$$

When V_{IN} is greater than V_{REF} , the output is high. For the comparator to switch back to a low state, V_{IN} must drop below V_{IN2} . Use [Equation 5](#) to calculate V_{IN2} .

$$V_{IN2} = \frac{V_{REF} (R1 + R2) - V_{CC} \times R1}{R2} \quad (5)$$

The hysteresis of this circuit is the difference between V_{IN1} and V_{IN2} , as shown in [Equation 6](#).

$$\Delta V_{IN} = V_{CC} \times \frac{R1}{R2} \quad (6)$$

For more information, please see Application Notes SNOA997 "Inverting comparator with hysteresis circuit" and SBOA313 "Non-Inverting Comparator With Hysteresis Circuit".

8.1.2.3 Inverting and Non-Inverting Hysteresis using Open-Drain Output

An open drain output device, such as the TLV182x-Q1, can also be used, but the output pull-up resistor must also be taken into account in the calculations. The pull-up resistor is seen in series with the feedback resistor when the output is high. Thus, the feedback resistor is actually seen as $R2 + R_{PULLUP}$. TI recommends that the pull-up resistor be at least 10 times less than the feedback resistor value.

8.2 Typical Applications

8.2.1 Window Comparator

Window comparators are commonly used to detect undervoltage and overvoltage conditions. [Figure 8-7](#) shows a simple window comparator circuit. Window comparators require open drain outputs (TLV182x-Q1) if the outputs are directly connected together.

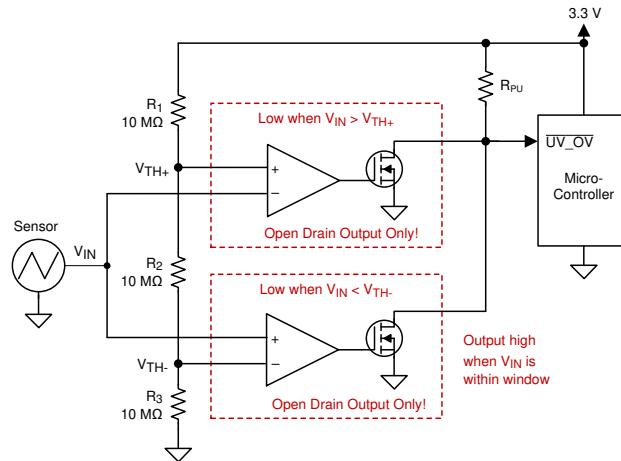

Figure 8-7. Window Comparator

8.2.1.1 Design Requirements

For this design, follow these design requirements:

- UV_Alert (logic low output) when the 24V supply is less than 19.2V
- OV_Alert (logic low output) when the 24V supply is greater than 30V
- Current dissipated in the resistor string is 30uA
- Comparator operates from the 5V supply
- 2.5V external reference is used

8.2.1.2 Detailed Design Procedure

Configure the circuit as shown in the circuit above where the 2.5V REF from the TLC3702-EP is used as the reference voltage and the resistor string of R1, R2, and R3 define the upper and lower threshold voltages for the 24V PLC power supply. When the comparator detects that the 24V supply has exceeded the maximum voltage of 30V or has drooped below the minimum voltage of 19.2V, OV_Alert and UV_Alert nets are pulled to a logic LOW state.

The first step is to determine the sum total resistance of the resistor string (R1, R2, R3) using the dissipation limit of 30uA. With a maximum operating voltage of 30V, the resistor string draws 30uA if the total resistance of R1+R2+R3 is 1Mohm.

The second step is to set the value of R3 such that the lower comparator changes output state from HIGH to LOW when the 24V supply reaches 30V. This is achieved when the voltage at the junction of R2 and R3 is equal to the reference voltage of 2.5V. Since 30uA is passing through the resistor string at 30V, R3 can be calculated from $2.5V / 30\mu A$ which is approximately 83.3kΩ.

The third step is to set the value of R2 such that the upper comparator changes output state from HIGH to LOW when the 24V supply reaches 19.2V. This is achieved when the voltage at the junction of R1 and R2 is equal to the reference voltage of 2.5V. Since 19.2uA passes through the resistor string at 19.2V, R2 can be calculated from $(2.5V / 19.2\mu A) - R3$ which is approximately 46.9kΩ.

Lastly, the value of R1 is calculated from $1\text{Mohm} - (R2 + R3)$ which is approximately 870kΩ. Please note that standard 1% resistor values are selected for the circuit

The respective comparator outputs (OV_Alert and UV_Alert) are LOW when the 24V PLC power supply is less than 19.2V or greater than 30V. Likewise, the respective comparator outputs are HIGH when the 24V supply is within the range of 19.2V to 30V (within the "window"), as shown below.

8.2.1.3 Application Curve

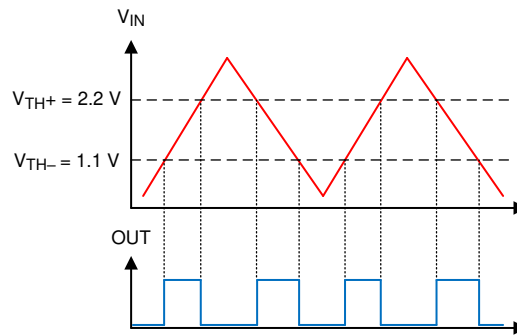

Figure 8-8. Window Comparator Results

For more information, please see Application note SBOA221 "[Window comparator circuit](#)".

8.2.2 Square-Wave Oscillator

Square-wave oscillator can be used as low cost timing reference or system supervisory clock source. A push-pull output (TLV181x-Q1) is recommended for best symmetry.

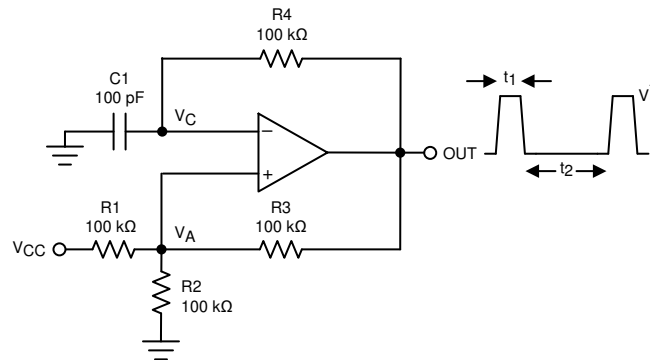

Figure 8-9. Square-Wave Oscillator

8.2.2.1 Design Requirements

The square-wave period is determined by the RC time constant of the capacitor C_1 and resistor R_4 . The maximum frequency is limited by propagation delay of the device and the capacitance load on the output. The low input bias current allows a lower capacitor value and larger resistor value combination for a given oscillator frequency, which helps to reduce BOM cost and board space. TI recommends that R_4 be over several $k\Omega$ to minimize loading the output.

8.2.2.2 Detailed Design Procedure

The oscillation frequency is determined by the resistor and capacitor values. The following calculation provides details of the steps.

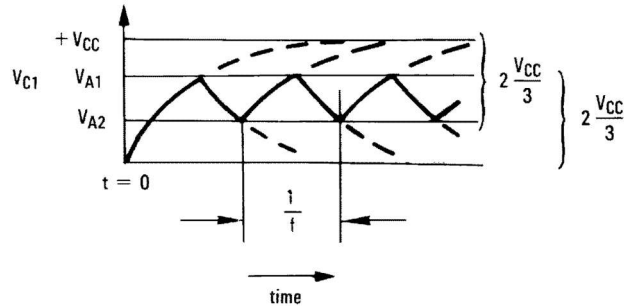

Figure 8-10. Square-Wave Oscillator Timing Thresholds

First consider the output of Figure [Figure 8-9](#) as high, which indicates the inverted input V_C is lower than the noninverting input (V_A). This causes the C_1 to be charged through R_4 , and the voltage V_C increases until equal to the noninverting input. The value of V_A at the point is calculated by [Equation 7](#).

$$V_{A1} = \frac{V_{CC} \times R_2}{R_2 + R_1 \parallel R_3} \quad (7)$$

if $R_1 = R_2 = R_3$, then $V_{A1} = 2V_{CC} / 3$

At this time the comparator output trips pulling down the output to the negative rail. The value of V_A at this point is calculated by [Equation 8](#).

$$V_{A2} = \frac{V_{CC}(R_2 \parallel R_3)}{R_1 + R_2 \parallel R_3} \quad (8)$$

if $R_1 = R_2 = R_3$, then $V_{A2} = V_{CC} / 3$

The C_1 now discharges through the R_4 , and the voltage V_{CC} decreases until reaching V_{A2} . At this point, the output switches back to the starting state. The oscillation period equals to the time duration for C_1 from $2V_{CC} / 3$ to $V_{CC} / 3$ then back to $2V_{CC} / 3$, which is given by $R_4 C_1 \times \ln 2$ for each trip. Therefore, the total time duration is calculated as $2R_4 C_1 \times \ln 2$.

The oscillation frequency can be obtained by [Equation 9](#):

$$f = 1 / (2 R_4 \times C_1 \times \ln 2) \quad (9)$$

8.2.2.3 Application Curve

[Figure 8-11](#) shows the simulated results of an oscillator using the following component values:

- $R_1 = R_2 = R_3 = R_4 = 100\text{k}\Omega$
- $C_1 = 100\text{pF}$, $C_L = 20\text{pF}$
- $V_+ = 5\text{V}$, $V_- = \text{GND}$
- C_{stray} (not shown) from V_A TO $\text{GND} = 10\text{pF}$

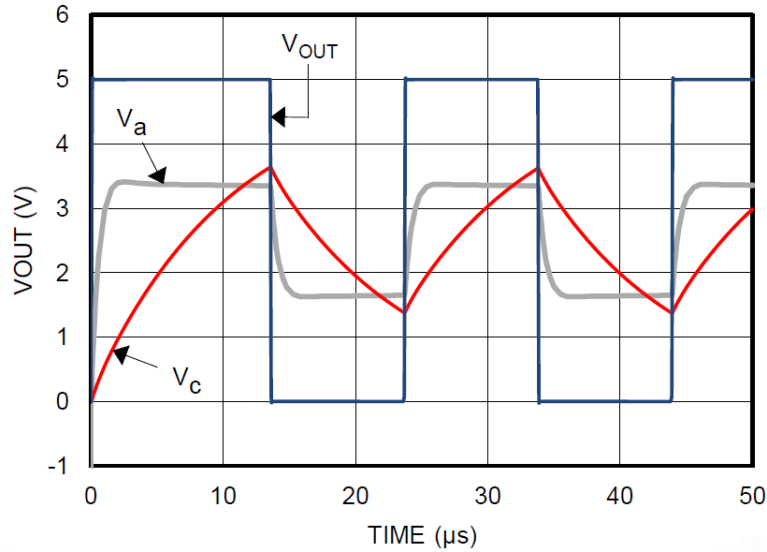

Figure 8-11. Square-Wave Oscillator Output Waveform

8.2.3 Adjustable Pulse Width Generator

Figure 8-12 is a variation on the Section 8.2.2 that allows adjusting the pulse widths.

R_4 and R_5 provide separate charge and discharge paths for the capacitor C depending on the output state.

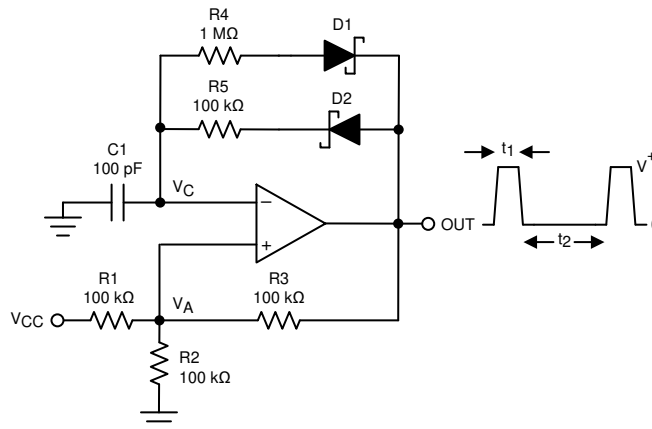

Figure 8-12. Adjustable Pulse Width Generator

The charge path is set through R_5 and D_2 when the output is high. Similarly, the discharge path for the capacitor is set by R_4 and D_1 when the output is low.

The pulse width t_1 is determined by the RC time constant of R_5 and C. Thus, the time t_2 between the pulses can be changed by varying R_4 , and the pulse width can be altered by R_5 . The frequency of the output can be changed by varying both R_4 and R_5 . At low voltages, the effects of the diode forward drop (0.8V, or 0.15V for Schottky) must be taken into account by altering output high and low voltages in the calculations.

8.2.4 Time Delay Generator

The circuit shown in Figure 8-13 provides output signals at a prescribed time interval from a time reference and automatically resets the output low when the input returns to 0V. This is useful for sequencing a "power on" signal to trigger a controlled start-up of power supplies.

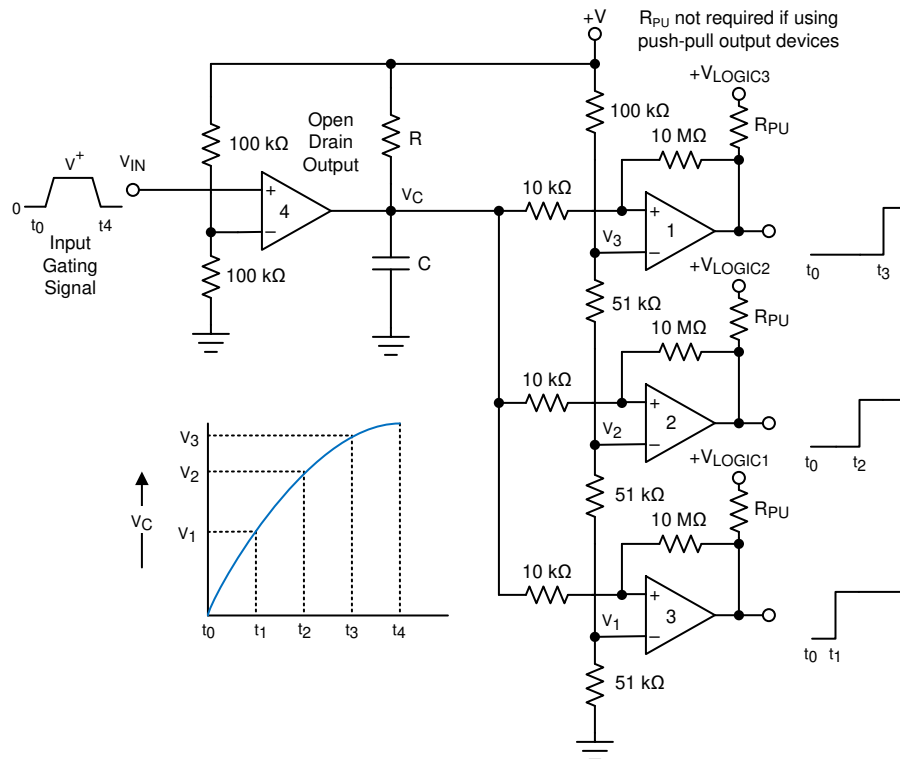

Figure 8-13. Time Delay Generator

Consider the case of $V_{IN} = 0$. The output of comparator 4 is also at ground, "shorting" the capacitor and holding the node at 0V. This implies that the outputs of comparators 1, 2, and 3 are also at 0V. When an input signal is applied, the output of open drain comparator 4 goes High-Z and C charges exponentially through R. This is indicated in the graph. The output voltages of comparators 1, 2, and 3 switch to the high state in sequence when V_C rises above the reference voltages V_1 , V_2 and V_3 . A small amount of hysteresis has been provided by the 10kΩ and 10MΩ resistors to insure fast switching when the RC time constant is chosen to give long delay times. A good starting point is $R = 100\text{k}\Omega$ and $C = 0.01\mu\text{F}$ to $1\mu\text{F}$.

All outputs immediately go low when V_{IN} falls to 0V, due to the comparator output going low and immediately discharging the capacitor.

Comparator 4 must be a open-drain type output (TLV182x-Q1), whereas comparators 1 though 3 can be either open drain or push-pull output, depending on system requirements. R_{PU} is not required for push-pull output devices.

8.2.5 Logic Level Shifter

The output of the TLV182x-Q1 is the uncommitted drain of the output transistor. Many open-drain outputs can be tied together to provide an output OR'ing function if desired.

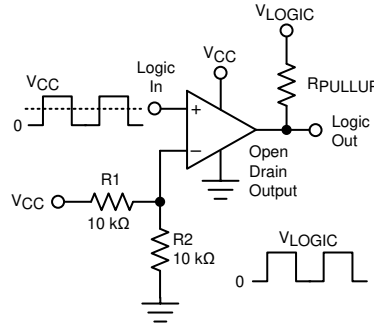

Figure 8-14. Universal Logic Level Shifter

The two 10kΩ resistors bias the input to half of the input logic supply level to set the threshold in the mid-point of the input logic levels. Only one shared output pull-up resistor is needed and can be connected to any pull-up voltage between 0V and 5.5V. The pullup voltage (V_{LOGIC}) must match the driven logic input "high" level.

8.2.6 One-Shot Multivibrator

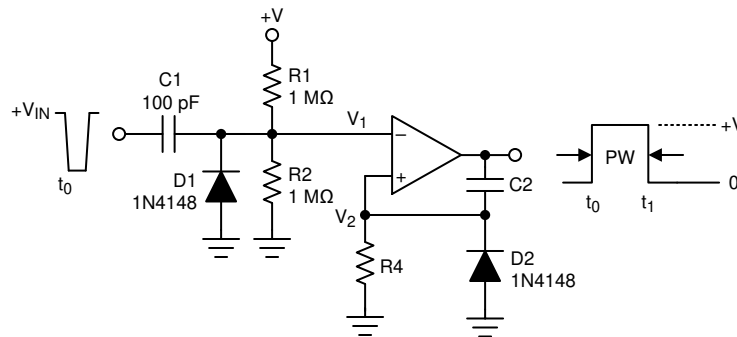

Figure 8-15. One-Shot Multivibrator

A monostable multivibrator has one stable state in which the circuit can remain indefinitely. The circuit can be triggered externally to another quasi-stable state. A monostable multivibrator can thus be used to generate a pulse of desired width.

The desired pulse width is set by adjusting the values of C_2 and R_4 . The resistor divider of R_1 and R_2 can be used to determine the magnitude of the input trigger pulse. The output changes state when $V_1 < V_2$. Diode D_2 provides a rapid discharge path for capacitor C_2 to reset at the end of the pulse. The diode also prevents the non-inverting input from being driven below ground.

8.2.7 Bi-Stable Multivibrator

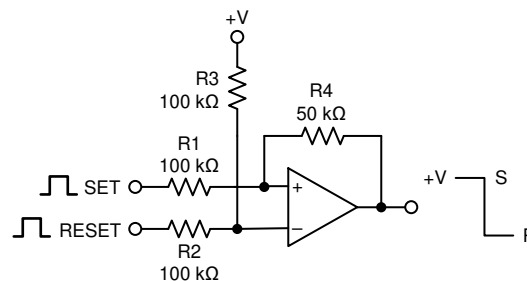

Figure 8-16. Bi-Stable Multivibrator

A bi-stable multivibrator has two stable states. The reference voltage is set up by the voltage divider of R_2 and R_3 . A pulse applied to the SET terminal switches the output of the comparator high. The resistor divider of R_1

and R4 now sets the non-inverting input to a voltage greater than the reference voltage. A pulse applied to RESET toggles the output low.

8.2.8 Zero Crossing Detector

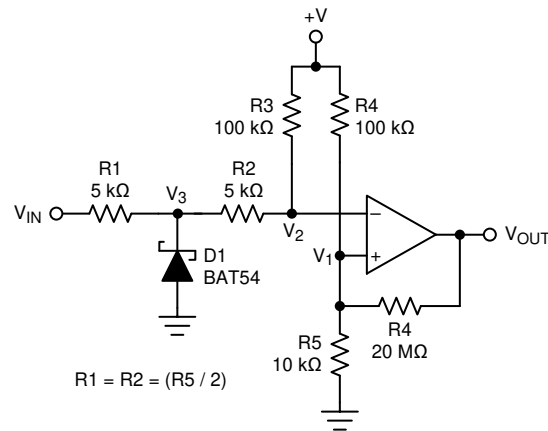

Figure 8-17. Zero Crossing Detector

A voltage divider of R₄ and R₅ establishes a reference voltage V₁ at the non-inverting input. By making the series resistance of R₁ and R₂ equal to R₅, the comparator output switches when V_{IN} = 0V. Diode D₁ clamps V₃ near ground. The voltage divider of R₂ and R₃ then prevents V₂ from going below ground. A small amount of hysteresis is setup to maintain rapid output voltage transitions.

8.2.9 Pulse Slicer

A Pulse Slicer is a variation of the Zero Crossing Detector and is used to detect the zero crossings on an input signal with a varying baseline level. This circuit works best with symmetrical waveforms. The RC network of R₁ and C₁ establishes an mean reference voltage V_{REF}, which tracks the mean amplitude of the V_{IN} signal. The non-inverting input is directly connected to V_{REF} through R₂. R₂ and R₃ are used to produce hysteresis to keep transitions free of spurious toggles. The time constant is a tradeoff between long-term symmetry and response time to changes in amplitude.

If the waveform is data, the data can be encoded in the recommended NRZ (Non-Return to Zero) format to maintain proper average baseline. Asymmetrical inputs can suffer from timing distortions caused by the changing V_{REF} average voltage.

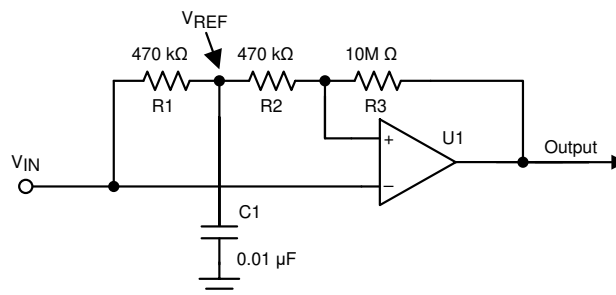

Figure 8-18. Pulse Slicer

For this design, follow these design requirements:

- The RC constant value (R₂ and C₁) must support the targeted data rate to maintain a valid tripping threshold.
- The hysteresis introduced with R₂ and R₄₃ helps to avoid spurious output toggles.

The TLV182x-Q1 can also be used, but with the addition of a pull-up resistor on the output (not shown for clarity).

Figure 8-19 shows the results of a 9600 baud data signal riding on a varying baseline.

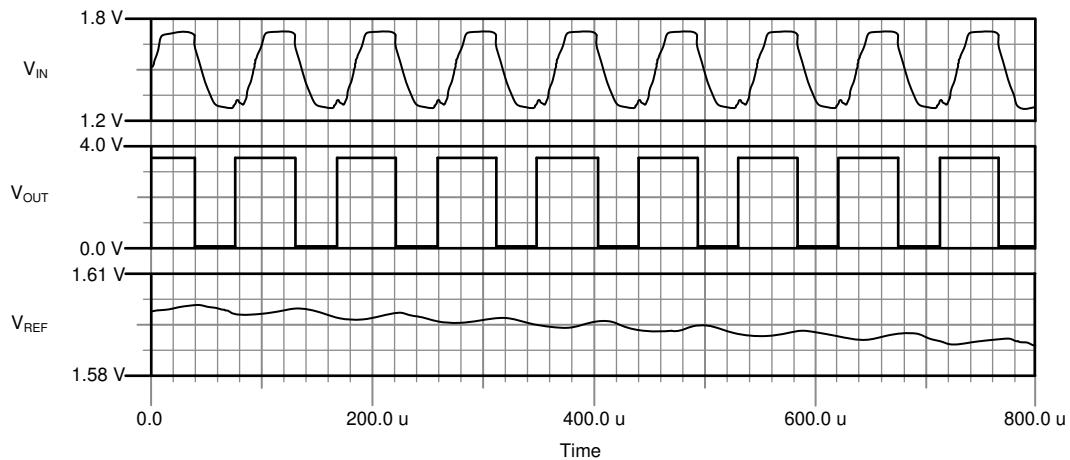

Figure 8-19. Pulse Slicer Waveforms

8.3 Power Supply Recommendations

Due to the fast output edge rates, bypass capacitors are critical on the supply pin to prevent supply ringing and false triggers and oscillations. Bypass the supply directly at *each* device with a low ESR 0.1 μ F ceramic bypass capacitor directly between V_{CC} pin and ground pins. Narrow, peak currents are drawn during the output transition time, particularly for the push-pull output device. These narrow pulses can cause un-bypassed supply lines and poor grounds to ring, possibly causing variation that can eat into the input voltage range and create an inaccurate comparison or even oscillations.

The device can be powered from both "split" supplies ($V+$ and $V-$), or "single" supplies ($V+$ and GND), with GND applied to the $V-$ pin. Input signals must stay within the specified input range (between $V+$ and $V-$) for either type. Note that with a "split" supply the output swings "low" (V_{OL}) to $V-$ potential and not GND.

8.4 Layout

8.4.1 Layout Guidelines

For accurate comparator applications, a clean, stable power supply is important to minimize output glitches. Output rise and fall times are in the tens of nanoseconds, and must be treated as high speed logic devices. The bypass capacitor must be as close to the supply pin as possible and connected to a solid ground plane, and preferably directly between the V_{CC} and GND pins.

Minimize coupling between outputs and inputs to prevent output oscillations. Do not run output and input traces in parallel unless there is a V_{CC} or GND trace between output to reduce coupling. When series resistance is added to inputs, place resistor close to the device. A low value ($\leq 100\Omega$) resistor can also be added in series with the output to dampen any ringing or reflections on long, non-impedance controlled traces. For best edge shapes, controlled impedance traces with back-terminations can be used when routing long distances.

8.4.2 Layout Example

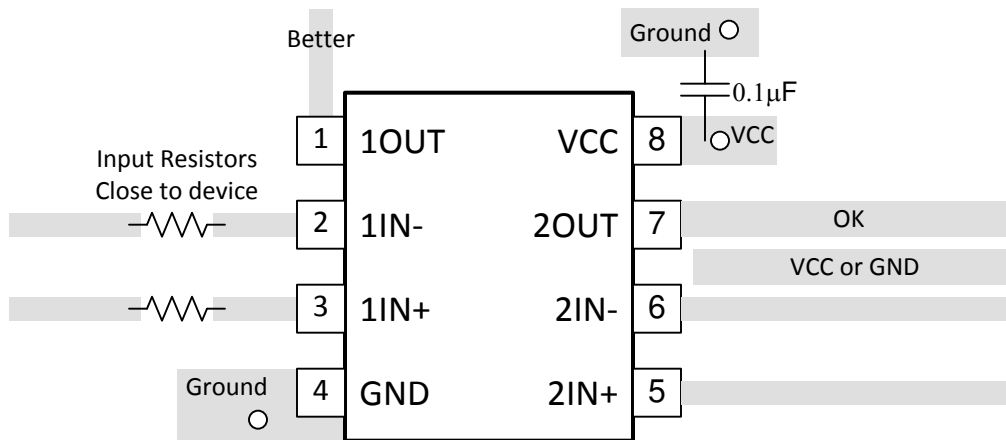

Figure 8-20. Dual Layout Example

9 Device and Documentation Support

9.1 Documentation Support

9.1.1 Related Documentation

- Texas Instruments, [Analog Engineers Circuit Cookbook: Amplifiers \(See Comparators section\) - SLYY137](#)
- Texas Instruments, [Precision Design, Comparator with Hysteresis Reference Design— TIDU020](#)
- Texas Instruments, [Window comparator circuit - SBOA221](#)
- Texas Instruments, [Reference Design, Window Comparator Reference Design— TIPD178](#)
- Texas Instruments, [Comparator with and without hysteresis circuit - SBOA219](#)
- Texas Instruments, [Inverting comparator with hysteresis circuit - SNOA997](#)
- Texas Instruments, [Non-Inverting Comparator With Hysteresis Circuit - SBOA313](#)
- Texas Instruments, [Zero crossing detection using comparator circuit - SNOA999](#)
- Texas Instruments, [PWM generator circuit - SBOA212](#)
- Texas Instruments, [How to Implement Comparators for Improving Performance of Rotary Encoder in Industrial Drive Applications - SNOAA41](#)
- Texas Instruments, [A Quad of Independently Func Comparators - SNOA654](#)

9.2 Receiving Notification of Documentation Updates

To receive notification of documentation updates, navigate to the device product folder on [ti.com](https://www.ti.com). Click on *Notifications* to register and receive a weekly digest of any product information that has changed. For change details, review the revision history included in any revised document.

9.3 Support Resources

[TI E2E™ support forums](#) are an engineer's go-to source for fast, verified answers and design help — straight from the experts. Search existing answers or ask your own question to get the quick design help you need.

Linked content is provided "AS IS" by the respective contributors. They do not constitute TI specifications and do not necessarily reflect TI's views; see TI's [Terms of Use](#).

9.4 Trademarks

TI E2E™ is a trademark of Texas Instruments.

All trademarks are the property of their respective owners.

9.5 Electrostatic Discharge Caution



This integrated circuit can be damaged by ESD. Texas Instruments recommends that all integrated circuits be handled with appropriate precautions. Failure to observe proper handling and installation procedures can cause damage.

ESD damage can range from subtle performance degradation to complete device failure. Precision integrated circuits may be more susceptible to damage because very small parametric changes could cause the device not to meet its published specifications.

9.6 Glossary

[TI Glossary](#)

This glossary lists and explains terms, acronyms, and definitions.

10 Revision History

NOTE: Page numbers for previous revisions may differ from page numbers in the current version.

Changes from Revision C (December 2024) to Revision D (May 2026)	Page
• Removed Preview from Quad WQFN.....	1
• Restored missing rows and tables.....	6

Changes from Revision B (September 2023) to Revision C (December 2024)	Page
• Replaced block digram and added graph.....	1

Changes from Revision A (March 2023) to Revision B (September 2023)	Page
• Removed previews for Duals and SOIC Quad releases.....	1

Changes from Revision * (October 2022) to Revision A (March 2023)	Page
• Removed previews for Single releases.....	1

11 Mechanical, Packaging, and Orderable Information

The following pages include mechanical, packaging, and orderable information. This information is the most current data available for the designated devices. This data is subject to change without notice and revision of this document. For browser-based versions of this data sheet, refer to the left-hand navigation.

PACKAGING INFORMATION

Orderable part number	Status (1)	Material type (2)	Package Pins	Package qty Carrier	RoHS (3)	Lead finish/ Ball material (4)	MSL rating/ Peak reflow (5)	Op temp (°C)	Part marking (6)
TLV1811LQDBVRQ1	Active	Production	SOT-23 (DBV) 5	3000 LARGE T&R	Yes	NIPDAU	Level-1-260C-UNLIM	-40 to 125	2XPT
TLV1811LQDBVRQ1.A	Active	Production	SOT-23 (DBV) 5	3000 LARGE T&R	Yes	NIPDAU	Level-1-260C-UNLIM	-40 to 125	2XPT
TLV1811QDBVRQ1	Active	Production	SOT-23 (DBV) 5	3000 LARGE T&R	Yes	NIPDAU	Level-1-260C-UNLIM	-40 to 125	2XOT
TLV1811QDBVRQ1.A	Active	Production	SOT-23 (DBV) 5	3000 LARGE T&R	Yes	NIPDAU	Level-1-260C-UNLIM	-40 to 125	2XOT
TLV1811QDCKRQ1	Active	Production	SC70 (DCK) 5	3000 LARGE T&R	Yes	NIPDAU	Level-1-260C-UNLIM	-40 to 125	2XWT
TLV1811QDCKRQ1.A	Active	Production	SC70 (DCK) 5	3000 LARGE T&R	Yes	NIPDAU	Level-1-260C-UNLIM	-40 to 125	2XWT
TLV1812QDDFRQ1	Active	Production	SOT-23-THIN (DDF) 8	3000 LARGE T&R	Yes	NIPDAU	Level-1-260C-UNLIM	-40 to 125	32BF
TLV1812QDDFRQ1.A	Active	Production	SOT-23-THIN (DDF) 8	3000 LARGE T&R	Yes	NIPDAU	Level-1-260C-UNLIM	-40 to 125	32BF
TLV1812QDGRQ1	Active	Production	VSSOP (DGK) 8	2500 LARGE T&R	Yes	NIPDAU	Level-1-260C-UNLIM	-40 to 125	31SS
TLV1812QDGRQ1.A	Active	Production	VSSOP (DGK) 8	2500 LARGE T&R	Yes	NIPDAU	Level-1-260C-UNLIM	-40 to 125	31SS
TLV1812QDRQ1	Active	Production	SOIC (D) 8	3000 LARGE T&R	Yes	NIPDAU	Level-1-260C-UNLIM	-40 to 125	T1812Q
TLV1812QDRQ1.A	Active	Production	SOIC (D) 8	3000 LARGE T&R	Yes	NIPDAU	Level-1-260C-UNLIM	-40 to 125	T1812Q
TLV1812QPWRQ1	Active	Production	TSSOP (PW) 8	3000 LARGE T&R	Yes	NIPDAU	Level-1-260C-UNLIM	-40 to 125	T1812Q
TLV1812QPWRQ1.A	Active	Production	TSSOP (PW) 8	3000 LARGE T&R	Yes	NIPDAU	Level-1-260C-UNLIM	-40 to 125	T1812Q
TLV1814QDRQ1	Active	Production	SOIC (D) 14	3000 LARGE T&R	Yes	NIPDAU	Level-1-260C-UNLIM	-40 to 125	TLV1814Q
TLV1814QDRQ1.A	Active	Production	SOIC (D) 14	3000 LARGE T&R	Yes	NIPDAU	Level-1-260C-UNLIM	-40 to 125	TLV1814Q
TLV1814QDYRQ1	Active	Production	SOT-23-THIN (DYY) 14	3000 LARGE T&R	Yes	NIPDAU	Level-1-260C-UNLIM	-40 to 125	TLV1814QB1
TLV1814QDYRQ1.A	Active	Production	SOT-23-THIN (DYY) 14	3000 LARGE T&R	Yes	NIPDAU	Level-1-260C-UNLIM	-40 to 125	TLV1814QB1
TLV1814QPWRQ1	Active	Production	TSSOP (PW) 14	3000 LARGE T&R	Yes	NIPDAU	Level-1-260C-UNLIM	-40 to 125	T1814BQ
TLV1814QPWRQ1.A	Active	Production	TSSOP (PW) 14	3000 LARGE T&R	Yes	NIPDAU	Level-1-260C-UNLIM	-40 to 125	T1814BQ
TLV1821LQDBVRQ1	Active	Production	SOT-23 (DBV) 5	3000 LARGE T&R	Yes	NIPDAU	Level-1-260C-UNLIM	-40 to 125	2XRT
TLV1821LQDBVRQ1.A	Active	Production	SOT-23 (DBV) 5	3000 LARGE T&R	Yes	NIPDAU	Level-1-260C-UNLIM	-40 to 125	2XRT
TLV1821QDBVRQ1	Active	Production	SOT-23 (DBV) 5	3000 LARGE T&R	Yes	NIPDAU	Level-1-260C-UNLIM	-40 to 125	2XQT
TLV1821QDBVRQ1.A	Active	Production	SOT-23 (DBV) 5	3000 LARGE T&R	Yes	NIPDAU	Level-1-260C-UNLIM	-40 to 125	2XQT
TLV1821QDCKRQ1	Active	Production	SC70 (DCK) 5	3000 LARGE T&R	Yes	NIPDAU	Level-1-260C-UNLIM	-40 to 125	2XVT
TLV1821QDCKRQ1.A	Active	Production	SC70 (DCK) 5	3000 LARGE T&R	Yes	NIPDAU	Level-1-260C-UNLIM	-40 to 125	2XVT
TLV1822QDDFRQ1	Active	Production	SOT-23-THIN (DDF) 8	3000 LARGE T&R	Yes	NIPDAU	Level-1-260C-UNLIM	-40 to 125	32CF
TLV1822QDDFRQ1.A	Active	Production	SOT-23-THIN (DDF) 8	3000 LARGE T&R	Yes	NIPDAU	Level-1-260C-UNLIM	-40 to 125	32CF

Orderable part number	Status (1)	Material type (2)	Package Pins	Package qty Carrier	RoHS (3)	Lead finish/ Ball material (4)	MSL rating/ Peak reflow (5)	Op temp (°C)	Part marking (6)
TLV1822QDQGRQ1	Active	Production	VSSOP (DGK) 8	2500 LARGE T&R	Yes	NIPDAU	Level-1-260C-UNLIM	-40 to 125	31TS
TLV1822QDQGRQ1.A	Active	Production	VSSOP (DGK) 8	2500 LARGE T&R	Yes	NIPDAU	Level-1-260C-UNLIM	-40 to 125	31TS
TLV1822QDRQ1	Active	Production	SOIC (D) 8	3000 LARGE T&R	Yes	NIPDAU	Level-1-260C-UNLIM	-40 to 125	T1822Q
TLV1822QDRQ1.A	Active	Production	SOIC (D) 8	3000 LARGE T&R	Yes	NIPDAU	Level-1-260C-UNLIM	-40 to 125	T1822Q
TLV1822QPWRQ1	Active	Production	TSSOP (PW) 8	3000 LARGE T&R	Yes	NIPDAU	Level-1-260C-UNLIM	-40 to 125	T1822Q
TLV1822QPWRQ1.A	Active	Production	TSSOP (PW) 8	3000 LARGE T&R	Yes	NIPDAU	Level-1-260C-UNLIM	-40 to 125	T1822Q
TLV1824QDRQ1	Active	Production	SOIC (D) 14	3000 LARGE T&R	Yes	NIPDAU	Level-1-260C-UNLIM	-40 to 125	TLV1824Q
TLV1824QDRQ1.A	Active	Production	SOIC (D) 14	3000 LARGE T&R	Yes	NIPDAU	Level-1-260C-UNLIM	-40 to 125	TLV1824Q
TLV1824QDYRQ1	Active	Production	SOT-23-THIN (DYY) 14	3000 LARGE T&R	Yes	NIPDAU	Level-1-260C-UNLIM	-40 to 125	LV1824QDYY
TLV1824QDYRQ1.A	Active	Production	SOT-23-THIN (DYY) 14	3000 LARGE T&R	Yes	NIPDAU	Level-1-260C-UNLIM	-40 to 125	LV1824QDYY
TLV1824QPWRQ1	Active	Production	TSSOP (PW) 14	3000 LARGE T&R	Yes	NIPDAU	Level-1-260C-UNLIM	-40 to 125	T1824BQ
TLV1824QPWRQ1.A	Active	Production	TSSOP (PW) 14	3000 LARGE T&R	Yes	NIPDAU	Level-1-260C-UNLIM	-40 to 125	T1824BQ

⁽¹⁾ **Status:** For more details on status, see our [product life cycle](#).

⁽²⁾ **Material type:** When designated, preproduction parts are prototypes/experimental devices, and are not yet approved or released for full production. Testing and final process, including without limitation quality assurance, reliability performance testing, and/or process qualification, may not yet be complete, and this item is subject to further changes or possible discontinuation. If available for ordering, purchases will be subject to an additional waiver at checkout, and are intended for early internal evaluation purposes only. These items are sold without warranties of any kind.

⁽³⁾ **RoHS values:** Yes, No, RoHS Exempt. See the [TI RoHS Statement](#) for additional information and value definition.

⁽⁴⁾ **Lead finish/Ball material:** Parts may have multiple material finish options. Finish options are separated by a vertical ruled line. Lead finish/Ball material values may wrap to two lines if the finish value exceeds the maximum column width.

⁽⁵⁾ **MSL rating/Peak reflow:** The moisture sensitivity level ratings and peak solder (reflow) temperatures. In the event that a part has multiple moisture sensitivity ratings, only the lowest level per JEDEC standards is shown. Refer to the shipping label for the actual reflow temperature that will be used to mount the part to the printed circuit board.

⁽⁶⁾ **Part marking:** There may be an additional marking, which relates to the logo, the lot trace code information, or the environmental category of the part.

Multiple part markings will be inside parentheses. Only one part marking contained in parentheses and separated by a "-" will appear on a part. If a line is indented then it is a continuation of the previous line and the two combined represent the entire part marking for that device.

Important Information and Disclaimer:The information provided on this page represents TI's knowledge and belief as of the date that it is provided. TI bases its knowledge and belief on information provided by third parties, and makes no representation or warranty as to the accuracy of such information. Efforts are underway to better integrate information from third parties. TI has taken and continues to take reasonable steps to provide representative and accurate information but may not have conducted destructive testing or chemical analysis on incoming materials and chemicals. TI and TI suppliers consider certain information to be proprietary, and thus CAS numbers and other limited information may not be available for release.

In no event shall TI's liability arising out of such information exceed the total purchase price of the TI part(s) at issue in this document sold by TI to Customer on an annual basis.

OTHER QUALIFIED VERSIONS OF TLV1811-Q1, TLV1812-Q1, TLV1814-Q1, TLV1821-Q1, TLV1822-Q1, TLV1824-Q1 :

- Catalog : [TLV1811](#), [TLV1812](#), [TLV1814](#), [TLV1821](#), [TLV1822](#), [TLV1824](#)
- Enhanced Product : [TLV1812-EP](#), [TLV1822-EP](#)

NOTE: Qualified Version Definitions:

- Catalog - TI's standard catalog product
- Enhanced Product - Supports Defense, Aerospace and Medical Applications

TAPE AND REEL INFORMATION

QUADRANT ASSIGNMENTS FOR PIN 1 ORIENTATION IN TAPE

*All dimensions are nominal

Device	Package Type	Package Drawing	Pins	SPQ	Reel Diameter (mm)	Reel Width W1 (mm)	A0 (mm)	B0 (mm)	K0 (mm)	P1 (mm)	W (mm)	Pin1 Quadrant
TLV1811LQDBVRQ1	SOT-23	DBV	5	3000	178.0	9.0	2.4	2.5	1.2	4.0	8.0	Q3
TLV1811QDBVRQ1	SOT-23	DBV	5	3000	178.0	9.0	2.4	2.5	1.2	4.0	8.0	Q3
TLV1811QDCKRQ1	SC70	DCK	5	3000	178.0	9.0	2.4	2.5	1.2	4.0	8.0	Q3
TLV1812QDDFRQ1	SOT-23-THIN	DDF	8	3000	180.0	8.4	3.2	3.2	1.4	4.0	8.0	Q3
TLV1812QDGKRQ1	VSSOP	DGK	8	2500	330.0	12.4	6.4	5.2	2.1	8.0	12.0	Q1
TLV1812QDRQ1	SOIC	D	8	3000	330.0	12.4	6.4	5.2	2.1	8.0	12.0	Q1
TLV1812QPWRQ1	TSSOP	PW	8	3000	330.0	12.4	7.0	3.6	1.6	8.0	12.0	Q1
TLV1814QDRQ1	SOIC	D	14	3000	330.0	16.4	6.5	9.0	2.1	8.0	16.0	Q1
TLV1814QDYRQ1	SOT-23-THIN	DYY	14	3000	330.0	12.4	4.8	3.6	1.6	8.0	12.0	Q3
TLV1814QPWRQ1	TSSOP	PW	14	3000	330.0	12.4	6.9	5.6	1.6	8.0	12.0	Q1
TLV1821LQDBVRQ1	SOT-23	DBV	5	3000	178.0	9.0	2.4	2.5	1.2	4.0	8.0	Q3
TLV1821QDBVRQ1	SOT-23	DBV	5	3000	178.0	9.0	2.4	2.5	1.2	4.0	8.0	Q3
TLV1821QDCKRQ1	SC70	DCK	5	3000	178.0	9.0	2.4	2.5	1.2	4.0	8.0	Q3
TLV1822QDDFRQ1	SOT-23-THIN	DDF	8	3000	180.0	8.4	3.2	3.2	1.4	4.0	8.0	Q3

Device	Package Type	Package Drawing	Pins	SPQ	Reel Diameter (mm)	Reel Width W1 (mm)	A0 (mm)	B0 (mm)	K0 (mm)	P1 (mm)	W (mm)	Pin1 Quadrant
TLV1822QDGKRQ1	VSSOP	DGK	8	2500	330.0	12.4	6.4	5.2	2.1	8.0	12.0	Q1
TLV1822QDRQ1	SOIC	D	8	3000	330.0	12.4	6.4	5.2	2.1	8.0	12.0	Q1
TLV1822QPWRQ1	TSSOP	PW	8	3000	330.0	12.4	7.0	3.6	1.6	8.0	12.0	Q1
TLV1824QDRQ1	SOIC	D	14	3000	330.0	16.4	6.5	9.0	2.1	8.0	16.0	Q1
TLV1824QDYRQ1	SOT-23-THIN	DYY	14	3000	330.0	12.4	4.8	3.6	1.6	8.0	12.0	Q3
TLV1824QPWRQ1	TSSOP	PW	14	3000	330.0	12.4	6.9	5.6	1.6	8.0	12.0	Q1

TAPE AND REEL BOX DIMENSIONS



*All dimensions are nominal

Device	Package Type	Package Drawing	Pins	SPQ	Length (mm)	Width (mm)	Height (mm)
TLV1811LQDBVRQ1	SOT-23	DBV	5	3000	180.0	180.0	18.0
TLV1811QDBVRQ1	SOT-23	DBV	5	3000	180.0	180.0	18.0
TLV1811QDCKRQ1	SC70	DCK	5	3000	180.0	180.0	18.0
TLV1812QDDFRQ1	SOT-23-THIN	DDF	8	3000	210.0	185.0	35.0
TLV1812QDGKRQ1	VSSOP	DGK	8	2500	353.0	353.0	32.0
TLV1812QDRQ1	SOIC	D	8	3000	353.0	353.0	32.0
TLV1812QPWRQ1	TSSOP	PW	8	3000	353.0	353.0	32.0
TLV1814QDRQ1	SOIC	D	14	3000	353.0	353.0	32.0
TLV1814QDYRQ1	SOT-23-THIN	DYY	14	3000	336.6	336.6	31.8
TLV1814QPWRQ1	TSSOP	PW	14	3000	353.0	353.0	32.0
TLV1821LQDBVRQ1	SOT-23	DBV	5	3000	180.0	180.0	18.0
TLV1821QDBVRQ1	SOT-23	DBV	5	3000	180.0	180.0	18.0
TLV1821QDCKRQ1	SC70	DCK	5	3000	180.0	180.0	18.0
TLV1822QDDFRQ1	SOT-23-THIN	DDF	8	3000	210.0	185.0	35.0
TLV1822QDGKRQ1	VSSOP	DGK	8	2500	353.0	353.0	32.0
TLV1822QDRQ1	SOIC	D	8	3000	353.0	353.0	32.0
TLV1822QPWRQ1	TSSOP	PW	8	3000	353.0	353.0	32.0
TLV1824QDRQ1	SOIC	D	14	3000	353.0	353.0	32.0

Device	Package Type	Package Drawing	Pins	SPQ	Length (mm)	Width (mm)	Height (mm)
TLV1824QDYRQ1	SOT-23-THIN	DYY	14	3000	336.6	336.6	31.8
TLV1824QPWRQ1	TSSOP	PW	14	3000	353.0	353.0	32.0

EXAMPLE BOARD LAYOUT

DBV0005A

SOT-23 - 1.45 mm max height

SMALL OUTLINE TRANSISTOR

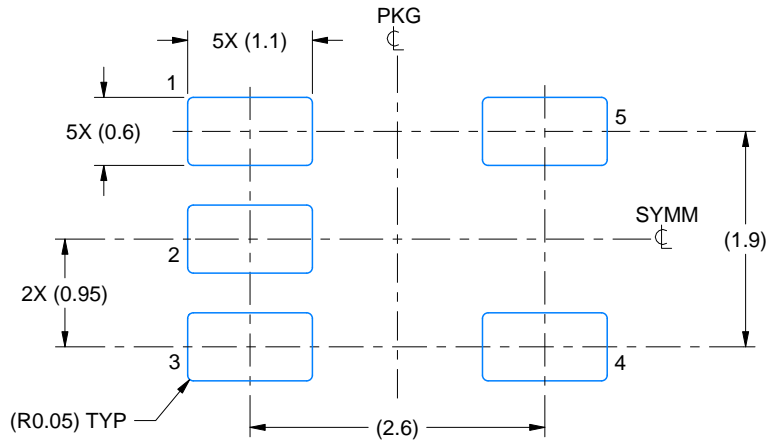

LAND PATTERN EXAMPLE
EXPOSED METAL SHOWN
SCALE:15X

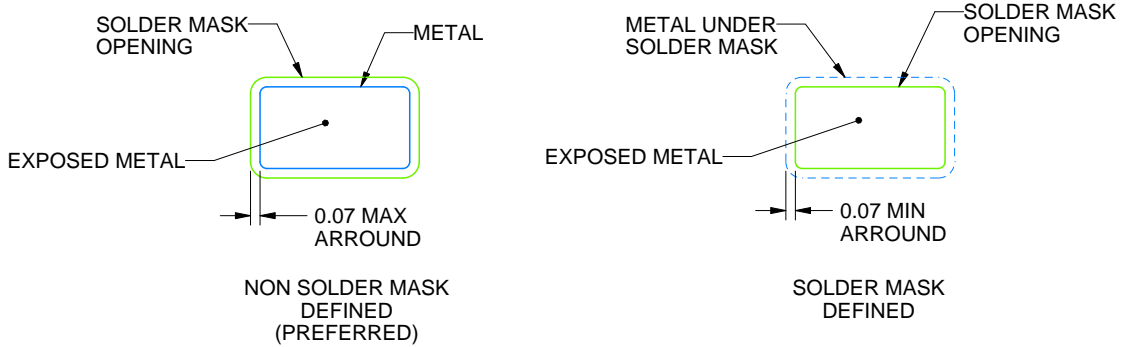

SOLDER MASK DETAILS

4214839/K 08/2024

NOTES: (continued)

- 6. Publication IPC-7351 may have alternate designs.
- 7. Solder mask tolerances between and around signal pads can vary based on board fabrication site.

EXAMPLE STENCIL DESIGN

DBV0005A

SOT-23 - 1.45 mm max height

SMALL OUTLINE TRANSISTOR



SOLDER PASTE EXAMPLE
BASED ON 0.125 mm THICK STENCIL
SCALE:15X

4214839/K 08/2024

NOTES: (continued)

8. Laser cutting apertures with trapezoidal walls and rounded corners may offer better paste release. IPC-7525 may have alternate design recommendations.
9. Board assembly site may have different recommendations for stencil design.

DGK0008A



PACKAGE OUTLINE

VSSOP - 1.1 mm max height

SMALL OUTLINE PACKAGE

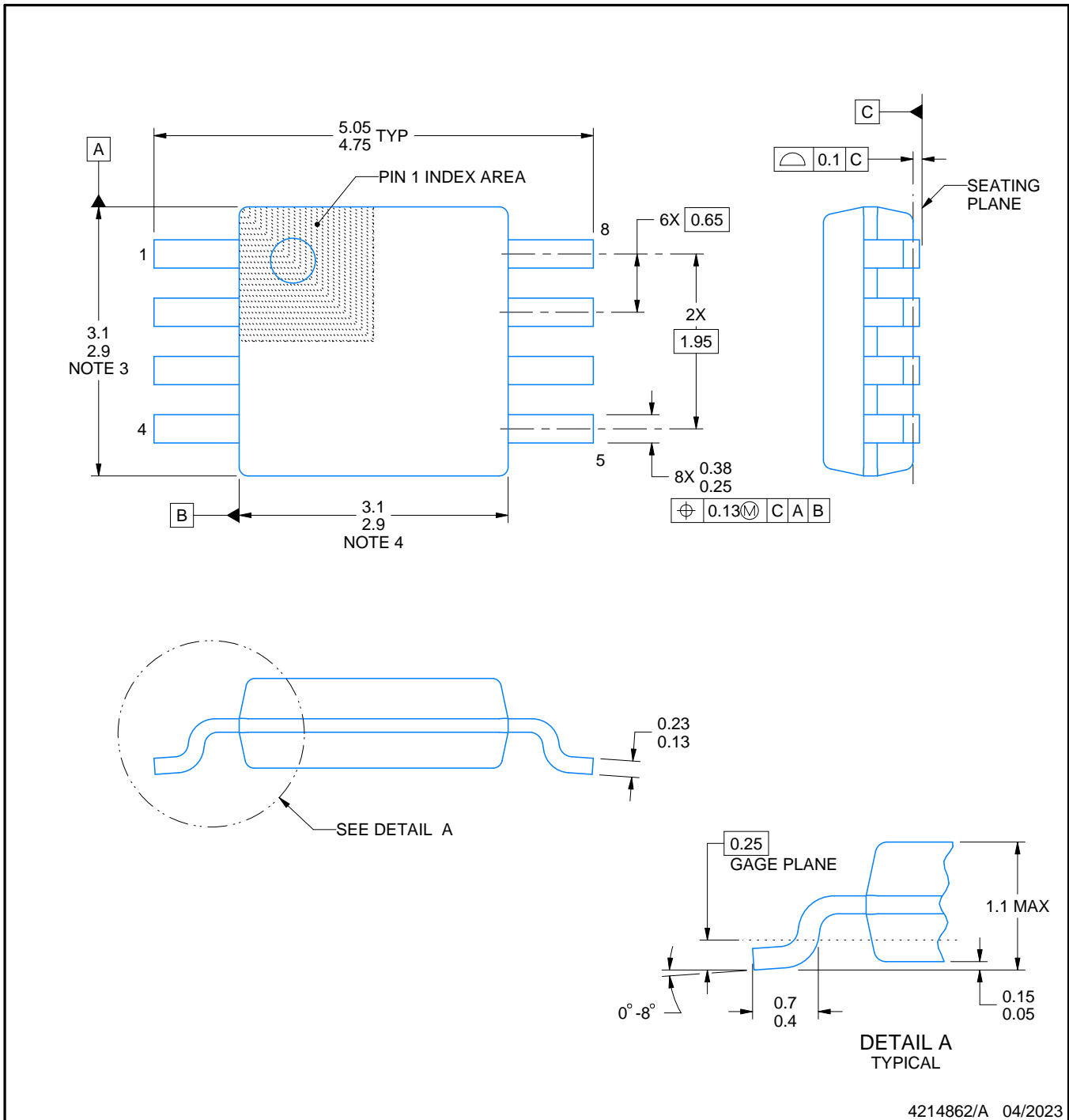

4214862/A 04/2023

NOTES:

PowerPAD is a trademark of Texas Instruments.

1. All linear dimensions are in millimeters. Any dimensions in parenthesis are for reference only. Dimensioning and tolerancing per ASME Y14.5M.
2. This drawing is subject to change without notice.
3. This dimension does not include mold flash, protrusions, or gate burrs. Mold flash, protrusions, or gate burrs shall not exceed 0.15 mm per side.
4. This dimension does not include interlead flash. Interlead flash shall not exceed 0.25 mm per side.
5. Reference JEDEC registration MO-187.

EXAMPLE BOARD LAYOUT

DGK0008A

™ VSSOP - 1.1 mm max height

SMALL OUTLINE PACKAGE



LAND PATTERN EXAMPLE
EXPOSED METAL SHOWN
SCALE: 15X



SOLDER MASK DETAILS

4214862/A 04/2023

NOTES: (continued)

6. Publication IPC-7351 may have alternate designs.
7. Solder mask tolerances between and around signal pads can vary based on board fabrication site.
8. Vias are optional depending on application, refer to device data sheet. If any vias are implemented, refer to their locations shown on this view. It is recommended that vias under paste be filled, plugged or tented.
9. Size of metal pad may vary due to creepage requirement.

EXAMPLE STENCIL DESIGN

DGK0008A

™ VSSOP - 1.1 mm max height

SMALL OUTLINE PACKAGE



SOLDER PASTE EXAMPLE
SCALE: 15X

4214862/A 04/2023

NOTES: (continued)

11. Laser cutting apertures with trapezoidal walls and rounded corners may offer better paste release. IPC-7525 may have alternate design recommendations.
12. Board assembly site may have different recommendations for stencil design.



4224643/D 07/2024

NOTES:

1. All linear dimensions are in millimeters. Any dimensions in parenthesis are for reference only. Dimensioning and tolerancing per ASME Y14.5M.
2. This drawing is subject to change without notice.
3. This dimension does not include mold flash, protrusions, or gate burrs. Mold flash, protrusions, or gate burrs shall not exceed 0.15 per side.
4. This dimension does not include interlead flash. Interlead flash shall not exceed 0.50 per side.
5. Reference JEDEC Registration MO-345, Variation AB

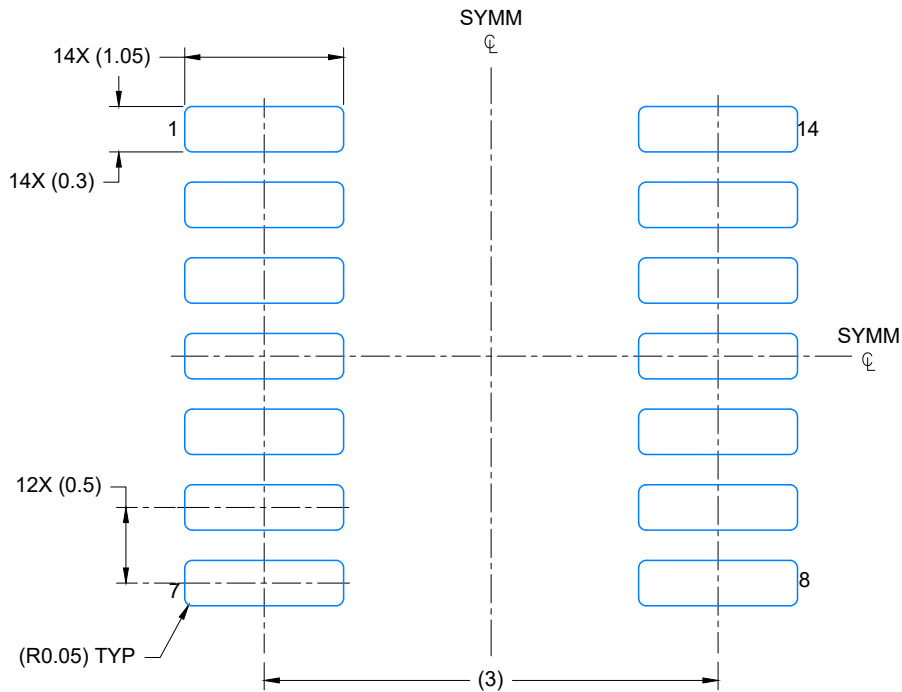

LAND PATTERN EXAMPLE
EXPOSED METAL SHOWN
SCALE: 20X

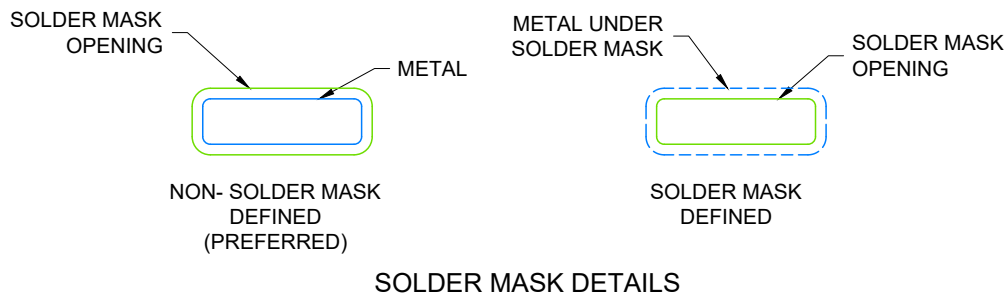

4224643/D 07/2024

NOTES: (continued)

- 6. Publication IPC-7351 may have alternate designs.
- 7. Solder mask tolerances between and around signal pads can vary based on board fabrication site.

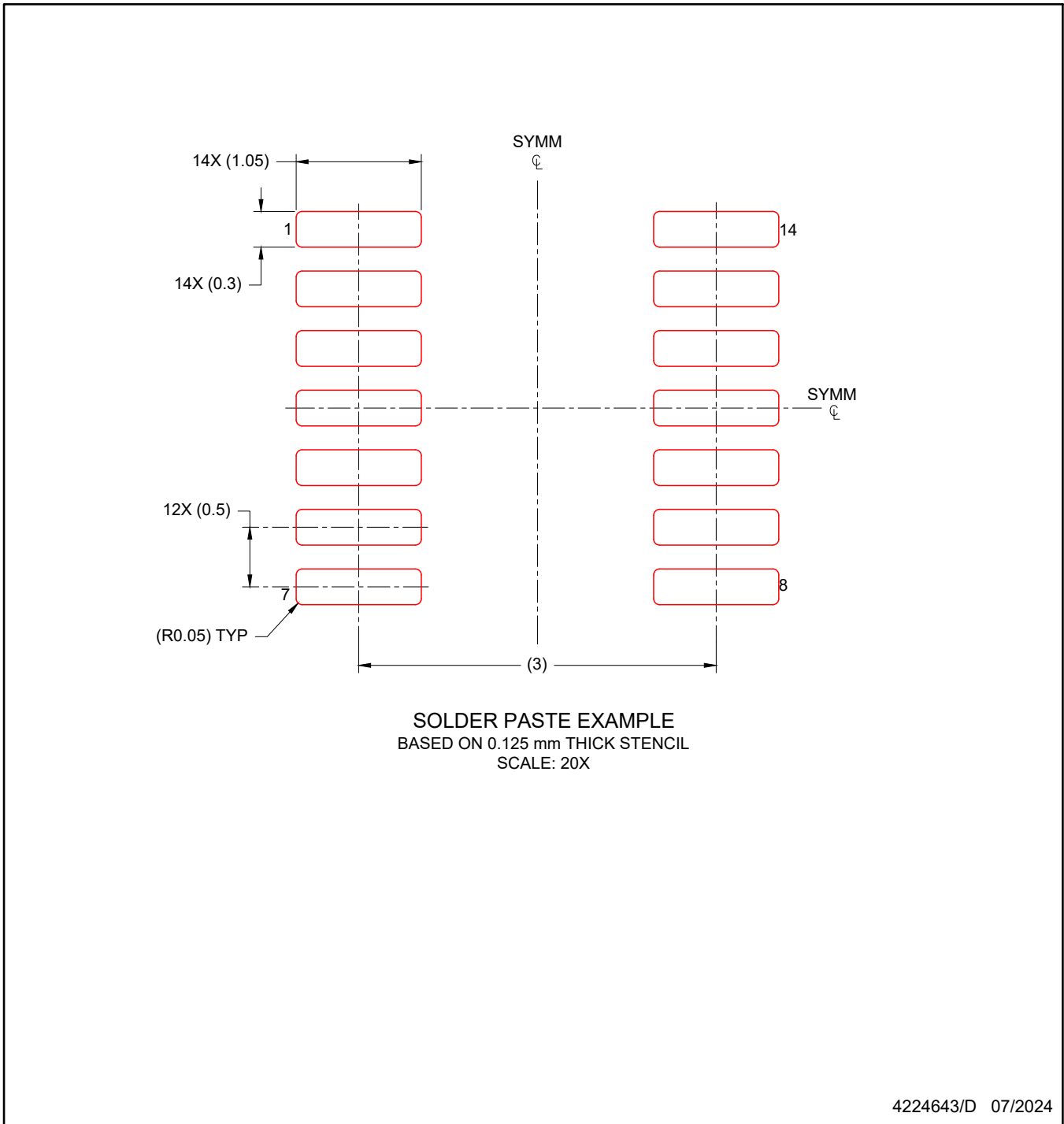

NOTES: (continued)

8. Laser cutting apertures with trapezoidal walls and rounded corners may offer better paste release. IPC-7525 may have alternate design recommendations.
9. Board assembly site may have different recommendations for stencil design.

D0014A

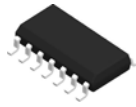

PACKAGE OUTLINE

SOIC - 1.75 mm max height

SMALL OUTLINE INTEGRATED CIRCUIT



4220718/A 09/2016

NOTES:

1. All linear dimensions are in millimeters. Dimensions in parenthesis are for reference only. Dimensioning and tolerancing per ASME Y14.5M.
2. This drawing is subject to change without notice.
3. This dimension does not include mold flash, protrusions, or gate burrs. Mold flash, protrusions, or gate burrs shall not exceed 0.15 mm, per side.
4. This dimension does not include interlead flash. Interlead flash shall not exceed 0.43 mm, per side.
5. Reference JEDEC registration MS-012, variation AB.

EXAMPLE BOARD LAYOUT

D0014A

SOIC - 1.75 mm max height

SMALL OUTLINE INTEGRATED CIRCUIT



LAND PATTERN EXAMPLE
SCALE:8X



SOLDER MASK DETAILS

4220718/A 09/2016

NOTES: (continued)

- 6. Publication IPC-7351 may have alternate designs.
- 7. Solder mask tolerances between and around signal pads can vary based on board fabrication site.

EXAMPLE STENCIL DESIGN

D0014A

SOIC - 1.75 mm max height

SMALL OUTLINE INTEGRATED CIRCUIT



SOLDER PASTE EXAMPLE
BASED ON 0.125 mm THICK STENCIL
SCALE:8X

4220718/A 09/2016

NOTES: (continued)

8. Laser cutting apertures with trapezoidal walls and rounded corners may offer better paste release. IPC-7525 may have alternate design recommendations.
9. Board assembly site may have different recommendations for stencil design.

DCK0005A



PACKAGE OUTLINE

SOT - 1.1 max height

SMALL OUTLINE TRANSISTOR

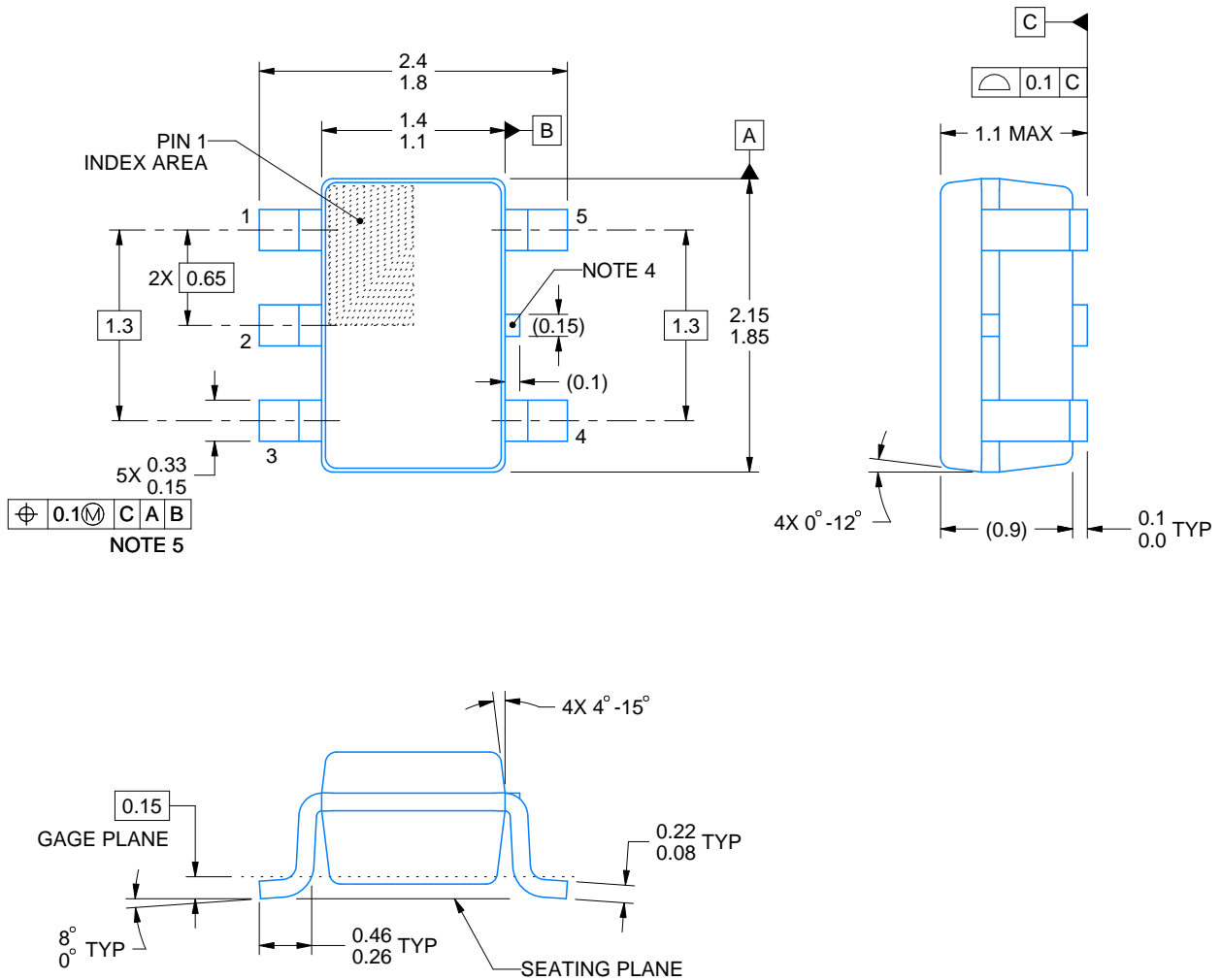

4214834/G 11/2024

NOTES:

1. All linear dimensions are in millimeters. Any dimensions in parenthesis are for reference only. Dimensioning and tolerancing per ASME Y14.5M.
2. This drawing is subject to change without notice.
3. Reference JEDEC MO-203.
4. Support pin may differ or may not be present.
5. Lead width does not comply with JEDEC.
6. Body dimensions do not include mold flash, protrusions, or gate burrs. Mold flash, protrusions, or gate burrs shall not exceed 0.25mm per side

EXAMPLE BOARD LAYOUT

DCK0005A

SOT - 1.1 max height

SMALL OUTLINE TRANSISTOR

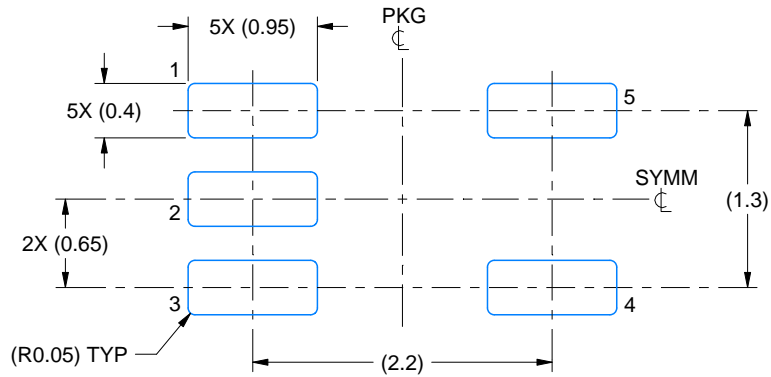

LAND PATTERN EXAMPLE
EXPOSED METAL SHOWN
SCALE:18X

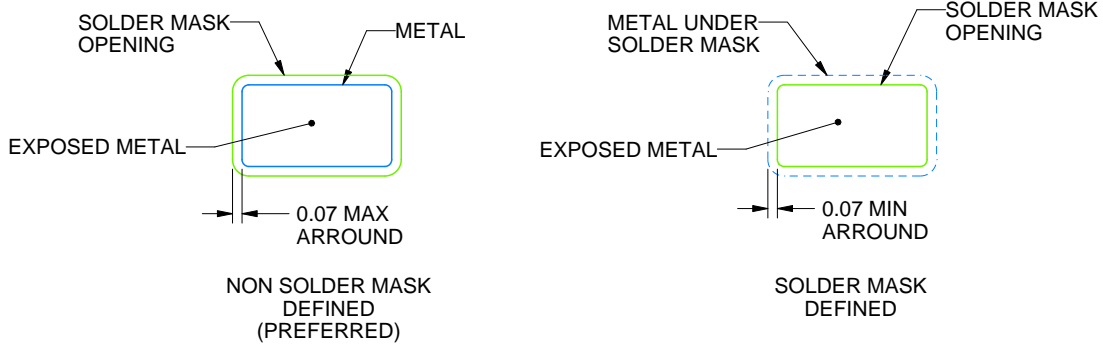

SOLDER MASK DETAILS

4214834/G 11/2024

NOTES: (continued)

- 7. Publication IPC-7351 may have alternate designs.
- 8. Solder mask tolerances between and around signal pads can vary based on board fabrication site.

EXAMPLE STENCIL DESIGN

DCK0005A

SOT - 1.1 max height

SMALL OUTLINE TRANSISTOR

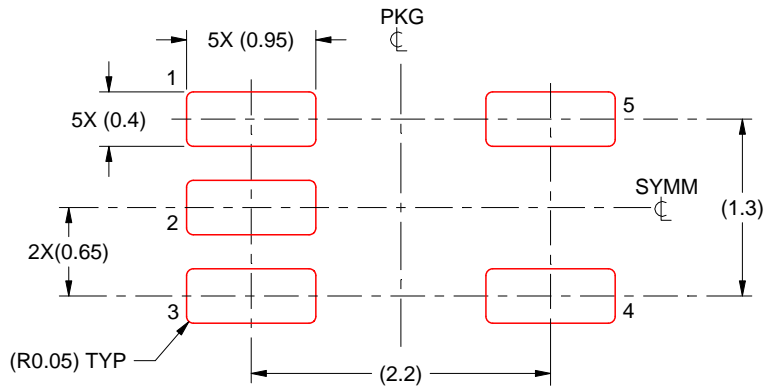

SOLDER PASTE EXAMPLE
BASED ON 0.125 THICK STENCIL
SCALE: 18X

4214834/G 11/2024

NOTES: (continued)

9. Laser cutting apertures with trapezoidal walls and rounded corners may offer better paste release. IPC-7525 may have alternate design recommendations.
10. Board assembly site may have different recommendations for stencil design.

DDF0008A



PACKAGE OUTLINE

SOT-23-THIN - 1.1 mm max height

PLASTIC SMALL OUTLINE

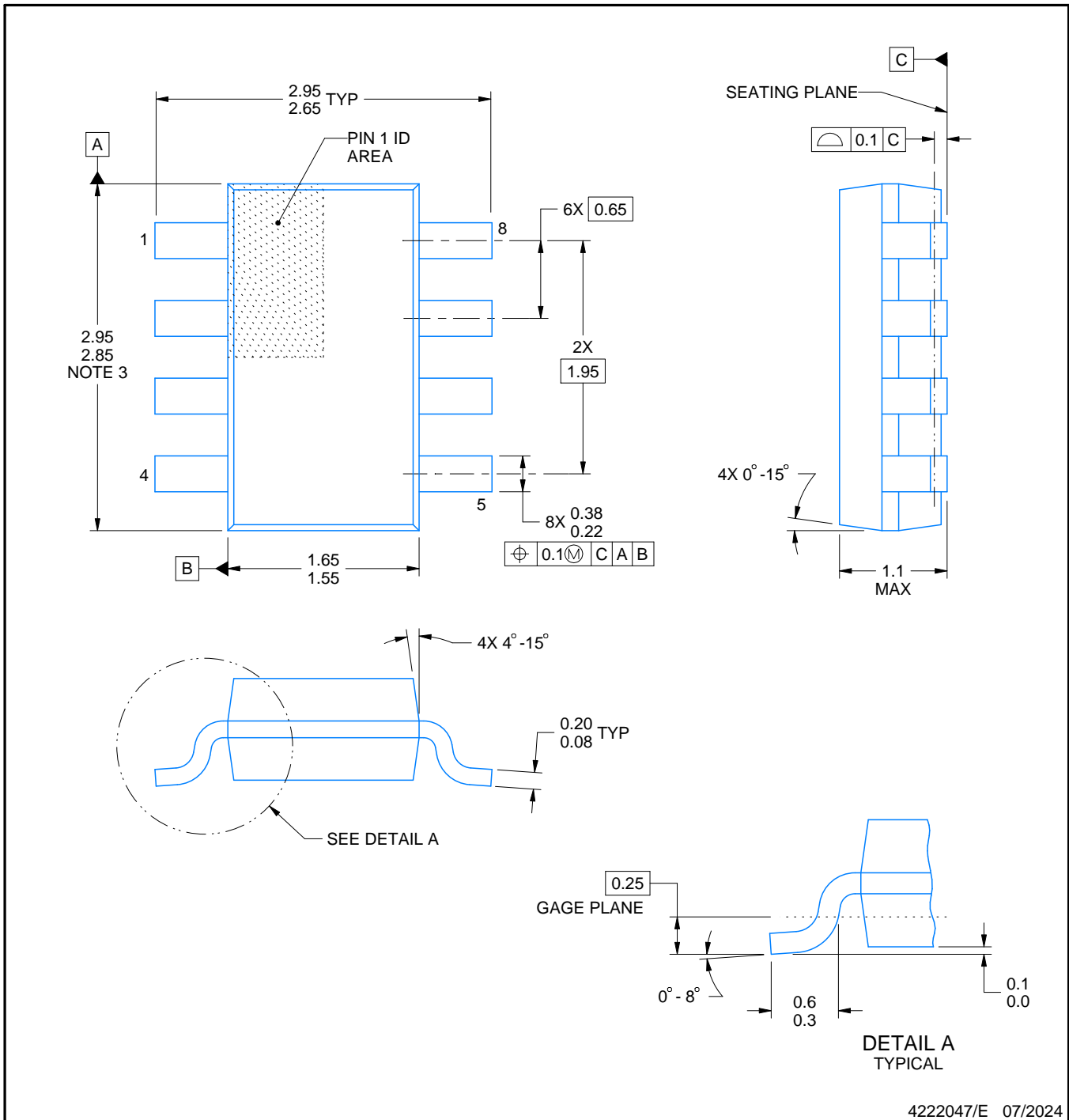

NOTES:

1. All linear dimensions are in millimeters. Any dimensions in parenthesis are for reference only. Dimensioning and tolerancing per ASME Y14.5M.
2. This drawing is subject to change without notice.
3. This dimension does not include mold flash, protrusions, or gate burrs. Mold flash, protrusions, or gate burrs shall not exceed 0.15 mm per side.

EXAMPLE BOARD LAYOUT

DDF0008A

SOT-23-THIN - 1.1 mm max height

PLASTIC SMALL OUTLINE

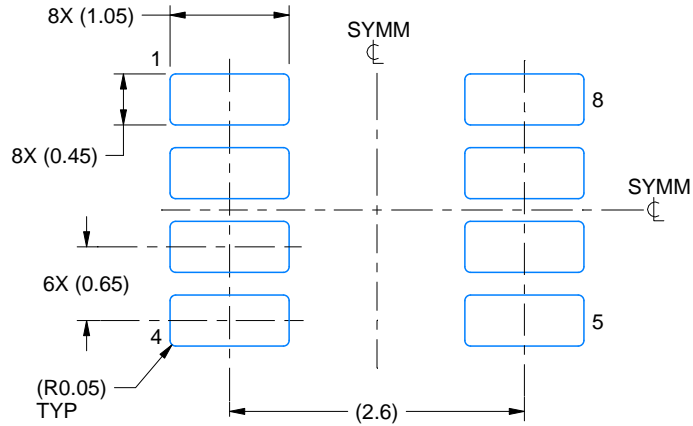

LAND PATTERN EXAMPLE
EXPOSED METAL SHOWN
SCALE:15X

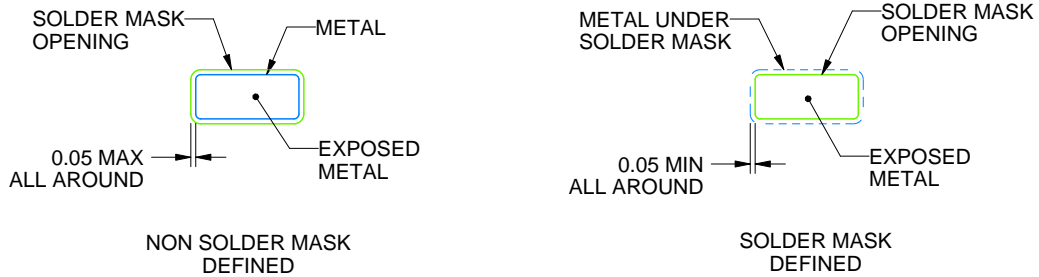

SOLDER MASK DETAILS

4222047/E 07/2024

NOTES: (continued)

- 4. Publication IPC-7351 may have alternate designs.
- 5. Solder mask tolerances between and around signal pads can vary based on board fabrication site.

EXAMPLE STENCIL DESIGN

DDF0008A

SOT-23-THIN - 1.1 mm max height

PLASTIC SMALL OUTLINE

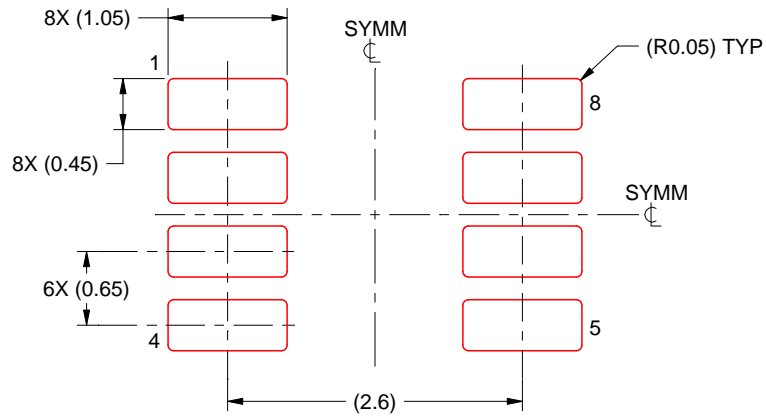

SOLDER PASTE EXAMPLE
BASED ON 0.125 mm THICK STENCIL
SCALE:15X

4222047/E 07/2024

NOTES: (continued)

6. Laser cutting apertures with trapezoidal walls and rounded corners may offer better paste release. IPC-7525 may have alternate design recommendations.
7. Board assembly site may have different recommendations for stencil design.



D0008A

PACKAGE OUTLINE

SOIC - 1.75 mm max height

SMALL OUTLINE INTEGRATED CIRCUIT



4214825/C 02/2019

NOTES:

- Linear dimensions are in inches [millimeters]. Dimensions in parenthesis are for reference only. Controlling dimensions are in inches. Dimensioning and tolerancing per ASME Y14.5M.
- This drawing is subject to change without notice.
- This dimension does not include mold flash, protrusions, or gate burrs. Mold flash, protrusions, or gate burrs shall not exceed .006 [0.15] per side.
- This dimension does not include interlead flash.
- Reference JEDEC registration MS-012, variation AA.

EXAMPLE BOARD LAYOUT

D0008A

SOIC - 1.75 mm max height

SMALL OUTLINE INTEGRATED CIRCUIT



LAND PATTERN EXAMPLE
EXPOSED METAL SHOWN
SCALE:8X



SOLDER MASK DETAILS

4214825/C 02/2019

NOTES: (continued)

6. Publication IPC-7351 may have alternate designs.

7. Solder mask tolerances between and around signal pads can vary based on board fabrication site.

EXAMPLE STENCIL DESIGN

D0008A

SOIC - 1.75 mm max height

SMALL OUTLINE INTEGRATED CIRCUIT

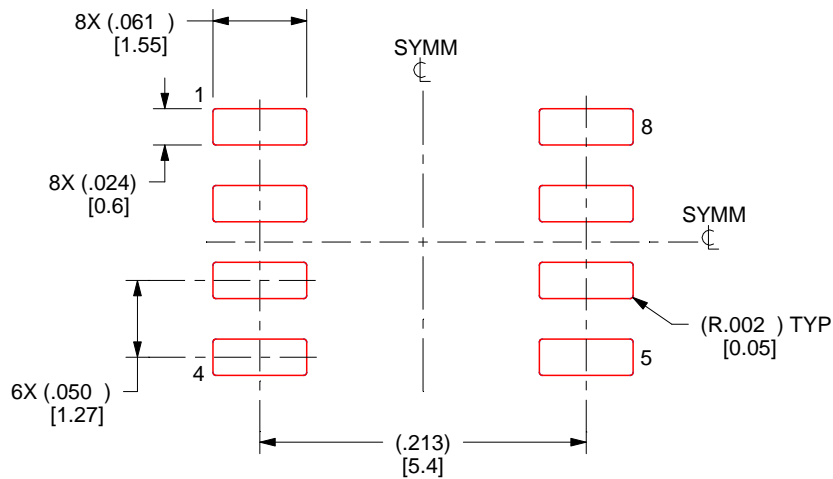

SOLDER PASTE EXAMPLE
BASED ON .005 INCH [0.125 MM] THICK STENCIL
SCALE:8X

4214825/C 02/2019

NOTES: (continued)

8. Laser cutting apertures with trapezoidal walls and rounded corners may offer better paste release. IPC-7525 may have alternate design recommendations.
9. Board assembly site may have different recommendations for stencil design.

PW0014A

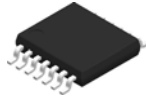

PACKAGE OUTLINE

TSSOP - 1.2 mm max height

SMALL OUTLINE PACKAGE

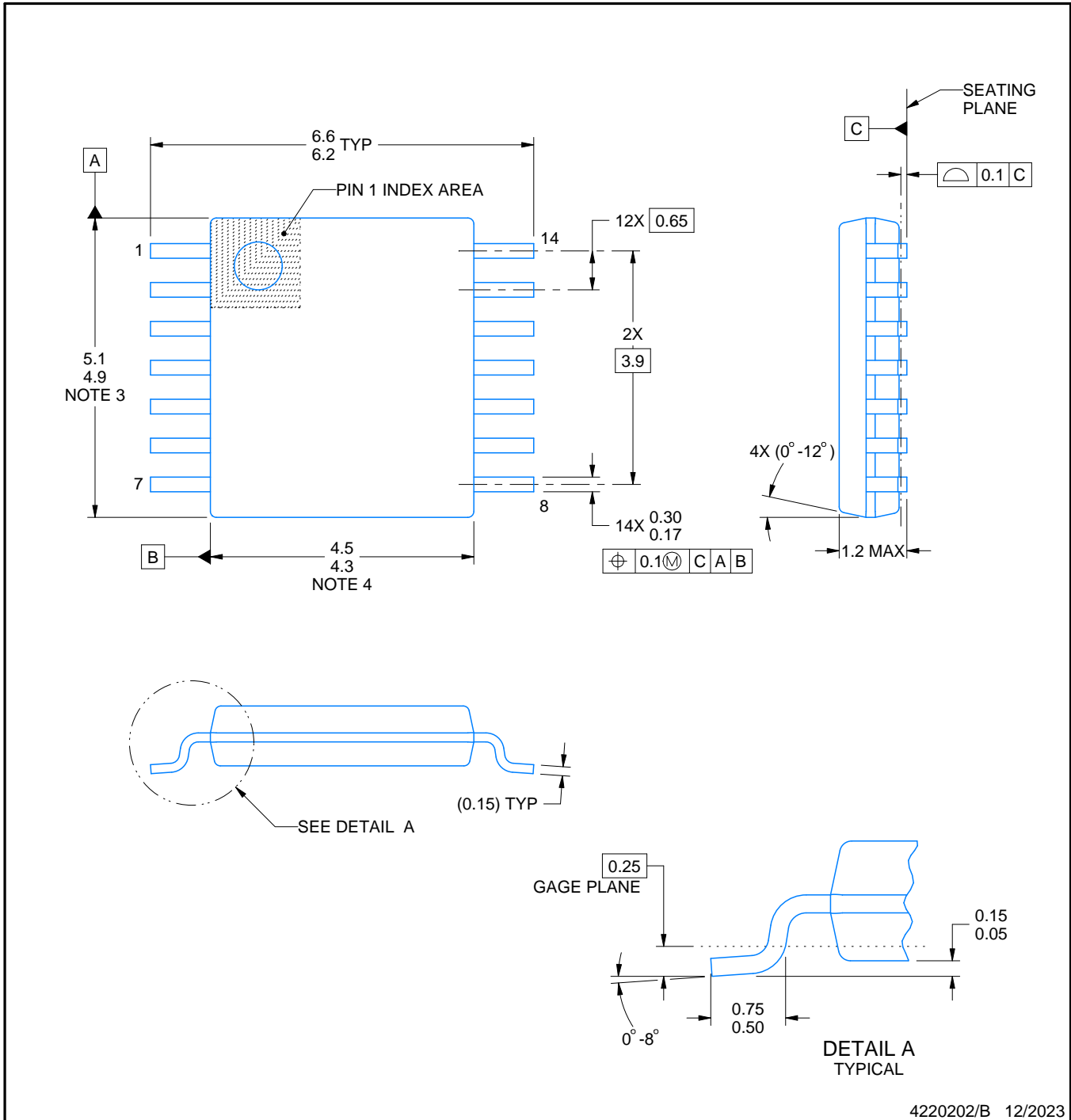

4220202/B 12/2023

NOTES:

1. All linear dimensions are in millimeters. Any dimensions in parenthesis are for reference only. Dimensioning and tolerancing per ASME Y14.5M.
2. This drawing is subject to change without notice.
3. This dimension does not include mold flash, protrusions, or gate burrs. Mold flash, protrusions, or gate burrs shall not exceed 0.15 mm per side.
4. This dimension does not include interlead flash. Interlead flash shall not exceed 0.25 mm per side.
5. Reference JEDEC registration MO-153.

EXAMPLE BOARD LAYOUT

PW0014A

TSSOP - 1.2 mm max height

SMALL OUTLINE PACKAGE

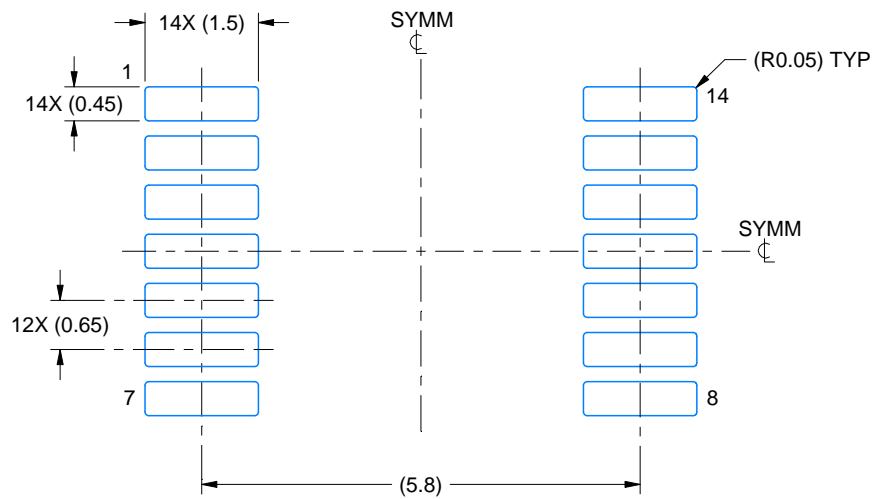

LAND PATTERN EXAMPLE
EXPOSED METAL SHOWN
SCALE: 10X

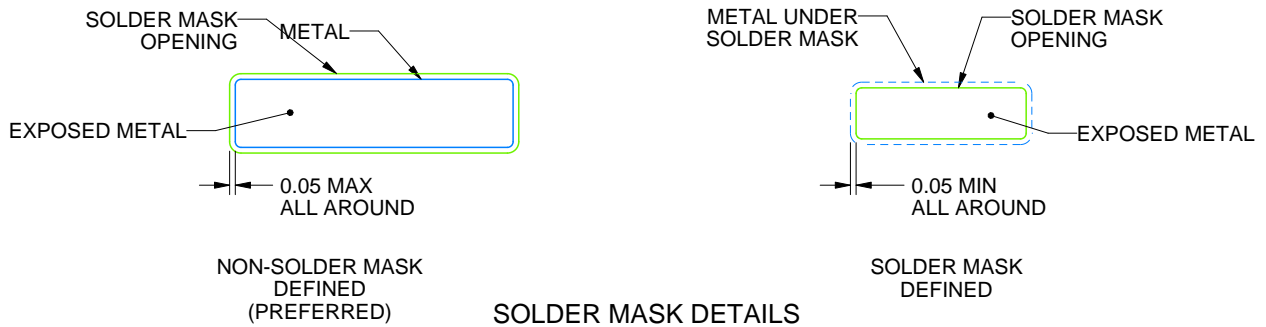

4220202/B 12/2023

NOTES: (continued)

- 6. Publication IPC-7351 may have alternate designs.
- 7. Solder mask tolerances between and around signal pads can vary based on board fabrication site.

EXAMPLE STENCIL DESIGN

PW0014A

TSSOP - 1.2 mm max height

SMALL OUTLINE PACKAGE

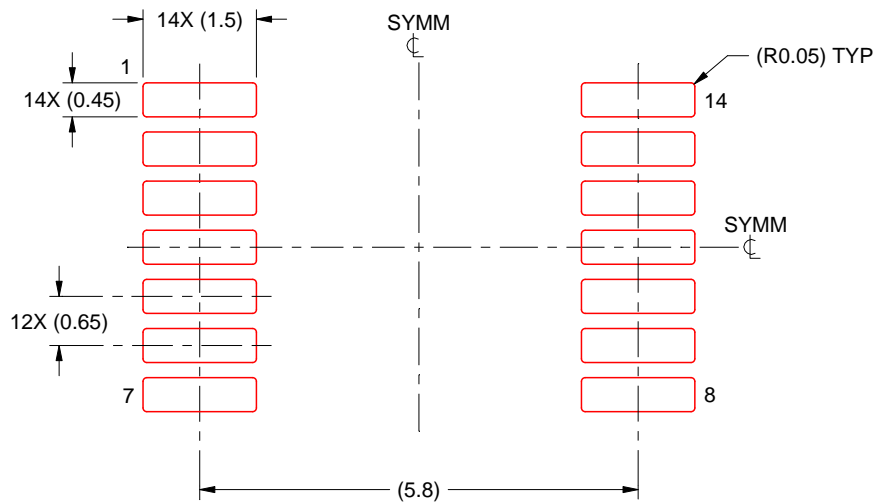

SOLDER PASTE EXAMPLE
BASED ON 0.125 mm THICK STENCIL
SCALE: 10X

4220202/B 12/2023

NOTES: (continued)

8. Laser cutting apertures with trapezoidal walls and rounded corners may offer better paste release. IPC-7525 may have alternate design recommendations.
9. Board assembly site may have different recommendations for stencil design.

PW0008A



PACKAGE OUTLINE

TSSOP - 1.2 mm max height

SMALL OUTLINE PACKAGE

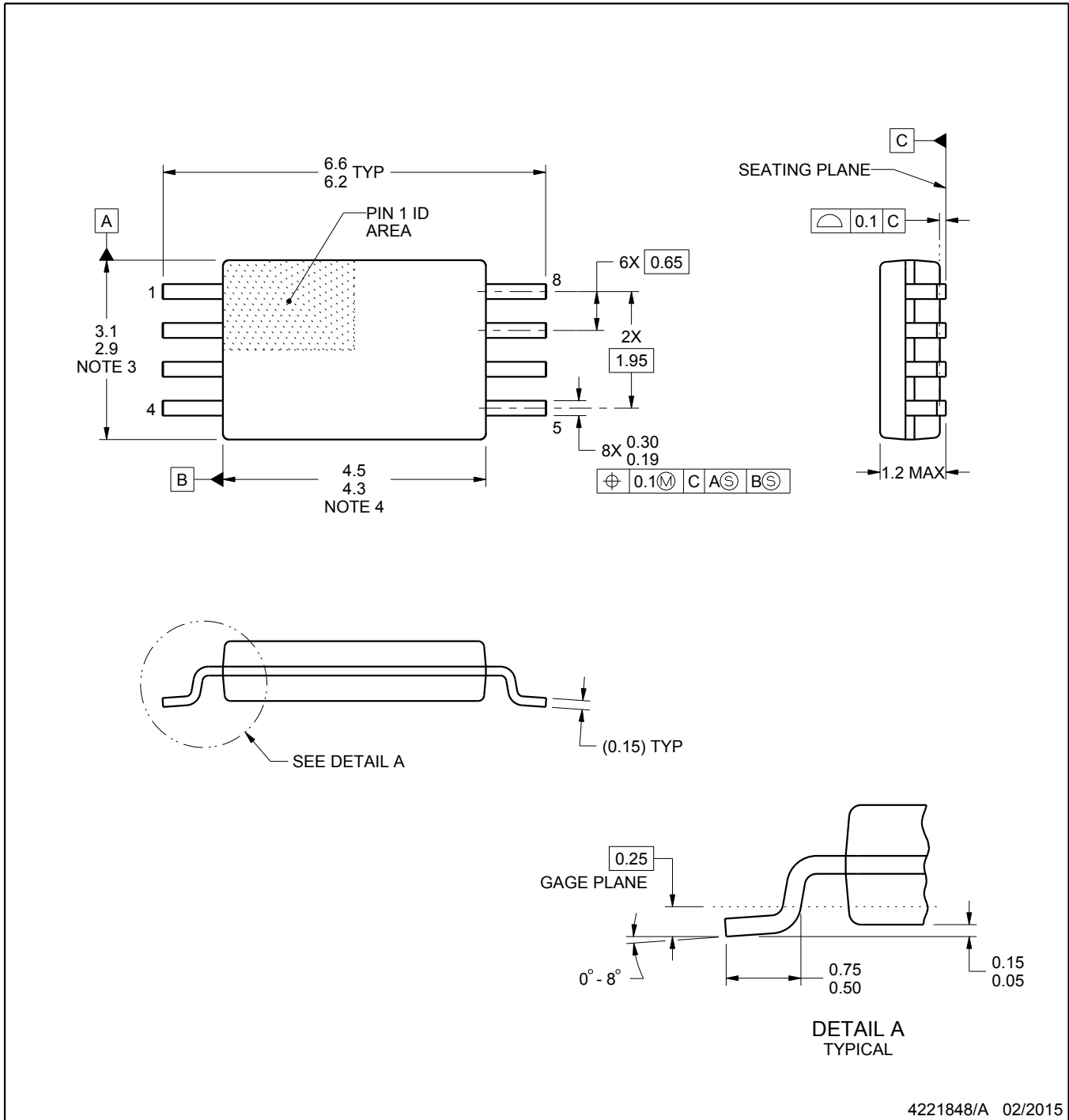

NOTES:

1. All linear dimensions are in millimeters. Any dimensions in parenthesis are for reference only. Dimensioning and tolerancing per ASME Y14.5M.
2. This drawing is subject to change without notice.
3. This dimension does not include mold flash, protrusions, or gate burrs. Mold flash, protrusions, or gate burrs shall not exceed 0.15 mm per side.
4. This dimension does not include interlead flash. Interlead flash shall not exceed 0.25 mm per side.
5. Reference JEDEC registration MO-153, variation AA.

EXAMPLE BOARD LAYOUT

PW0008A

TSSOP - 1.2 mm max height

SMALL OUTLINE PACKAGE

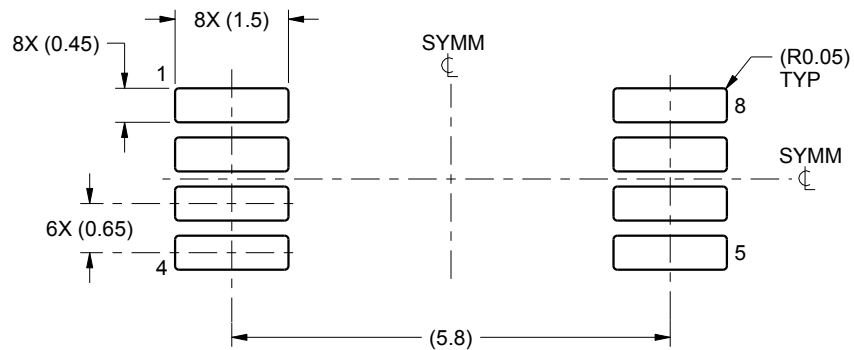

LAND PATTERN EXAMPLE
SCALE:10X

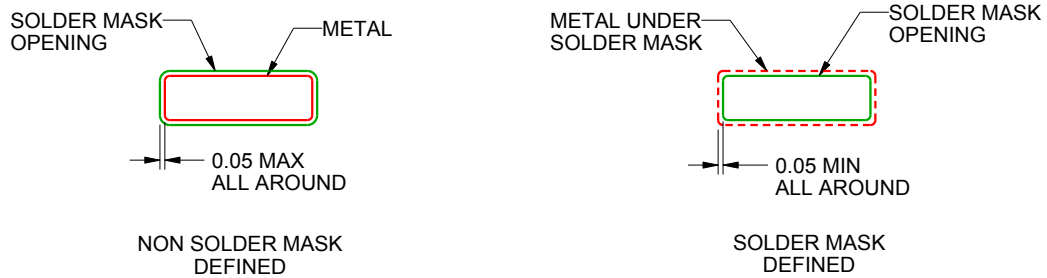

SOLDER MASK DETAILS
NOT TO SCALE

4221848/A 02/2015

NOTES: (continued)

- 6. Publication IPC-7351 may have alternate designs.
- 7. Solder mask tolerances between and around signal pads can vary based on board fabrication site.

EXAMPLE STENCIL DESIGN

PW0008A

TSSOP - 1.2 mm max height

SMALL OUTLINE PACKAGE

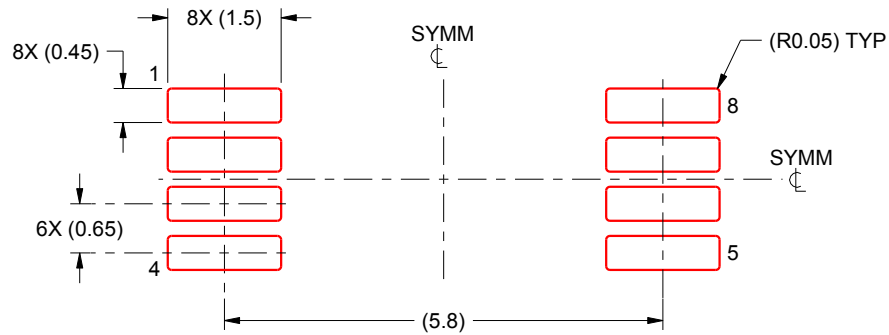

SOLDER PASTE EXAMPLE
BASED ON 0.125 mm THICK STENCIL
SCALE:10X

4221848/A 02/2015

NOTES: (continued)

8. Laser cutting apertures with trapezoidal walls and rounded corners may offer better paste release. IPC-7525 may have alternate design recommendations.
9. Board assembly site may have different recommendations for stencil design.

IMPORTANT NOTICE AND DISCLAIMER

TI PROVIDES TECHNICAL AND RELIABILITY DATA (INCLUDING DATASHEETS), DESIGN RESOURCES (INCLUDING REFERENCE DESIGNS), APPLICATION OR OTHER DESIGN ADVICE, WEB TOOLS, SAFETY INFORMATION, AND OTHER RESOURCES "AS IS" AND WITH ALL FAULTS, AND DISCLAIMS ALL WARRANTIES, EXPRESS AND IMPLIED, INCLUDING WITHOUT LIMITATION ANY IMPLIED WARRANTIES OF MERCHANTABILITY, FITNESS FOR A PARTICULAR PURPOSE OR NON-INFRINGEMENT OF THIRD PARTY INTELLECTUAL PROPERTY RIGHTS.

These resources are intended for skilled developers designing with TI products. You are solely responsible for (1) selecting the appropriate TI products for your application, (2) designing, validating and testing your application, and (3) ensuring your application meets applicable standards, and any other safety, security, regulatory or other requirements.

These resources are subject to change without notice. TI grants you permission to use these resources only for development of an application that uses the TI products described in the resource. Other reproduction and display of these resources is prohibited. No license is granted to any other TI intellectual property right or to any third party intellectual property right. TI disclaims responsibility for, and you fully indemnify TI and its representatives against any claims, damages, costs, losses, and liabilities arising out of your use of these resources.

TI's products are provided subject to [TI's Terms of Sale](#), [TI's General Quality Guidelines](#), or other applicable terms available either on ti.com or provided in conjunction with such TI products. TI's provision of these resources does not expand or otherwise alter TI's applicable warranties or warranty disclaimers for TI products. Unless TI explicitly designates a product as custom or customer-specified, TI products are standard, catalog, general purpose devices.

TI objects to and rejects any additional or different terms you may propose.

Copyright © 2026, Texas Instruments Incorporated

Last updated 10/2025