

SN74LVC1G66 Single Bilateral Analog Switch

1 Features

- Available in the Texas Instruments NanoFree™ Package
- 1.65V to 5.5V V_{CC} Operation
- Inputs Accept Voltages to 5.5V
- Max t_{pd} of 0.8ns at 3.3V
- High On-Off Output Voltage Ratio
- High Degree of Linearity
- High Speed, Typically 0.5ns ($V_{CC} = 3V$, $C_L = 50pF$)
- Low ON-State Resistance, Typically approximately 5.5Ω ($V_{CC} = 4.5V$)
- Latch-Up Performance Exceeds 100mA Per JESD 78, Class II
- ESD Protection Exceeds JESD 22
 - 2000V Human-Body Model (A114-A)
 - 200V Machine Model (A115-A)
 - 1000V Charged-Device Model (C101)

2 Applications

- Wireless Devices
- Audio and Video Signal Routing
- Portable Computing
- Wearable Devices
- Signal Gating, Chopping, Modulation or Demodulation (Modem)
- Signal Multiplexing for Analog-to-Digital and Digital-to-Analog Conversion Systems

3 Description

The SN74LVC1G66 single, bilateral analog switch is designed for 1.65V to 5.5V V_{CC} operation, and supports both analog and digital signals. SN74LVC1G66 permits bidirectional transmission of signals with amplitudes of up to 5.5V (peak). By using the die as the package, NanoFree package technology represents a significant advancement in IC packaging concepts.

Package Information

PART NUMBER	PACKAGE ⁽¹⁾	PACKAGE SIZE ⁽²⁾
SN74LVC1G66DBV	DBV (SOT-23, 5)	2.90mm × 2.80mm
SN74LVC1G66DCK	DCK (SC70, 5)	2.00mm × 2.10mm
SN74LVC1G66DRL	DRL (SOT, 5)	1.60mm × 1.60mm
SN74LVC1G66DRY	DRY (SON, 6)	1.45mm × 1.00mm
SN74LVC1G66YZP	YZP (DSBGA, 5)	1.39mm × 0.89mm
SN74LVC1G66DSF	DSF (SON, 6)	1.00mm × 1.00mm

- (1) For all available packages, see the orderable addendum at the end of the data sheet.
- (2) The package size (length × width) is a nominal value and includes pins, where applicable.

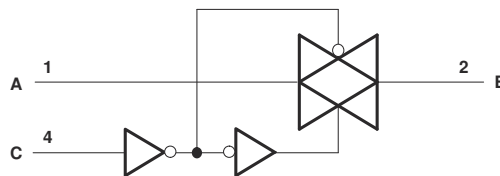

Logic Diagram (Positive Logic)



Table of Contents

1 Features	1	7.1 Overview.....	15
2 Applications	1	7.2 Functional Block Diagram.....	15
3 Description	1	7.3 Feature Description.....	15
4 Pin Configuration and Functions	3	7.4 Device Functional Modes.....	15
Pin Functions.....	4	8 Application and Implementation	16
Pin Functions.....	4	8.1 Application Information.....	16
5 Specifications	5	8.2 Typical Application.....	16
5.1 Absolute Maximum Ratings.....	5	8.3 Power Supply Recommendations.....	17
5.2 ESD Ratings.....	5	8.4 Layout.....	18
5.3 Recommended Operating Conditions.....	6	9 Device and Documentation Support	19
5.4 Thermal Information.....	6	9.1 Documentation Support.....	19
5.5 Electrical Characteristics.....	7	9.2 Receiving Notification of Documentation Updates....	19
5.6 Switching Characteristics: DBV, DCK.....	7	9.3 Support Resources.....	19
5.7 Switching Characteristics: DRL, DRY, YZP, DSF.....	8	9.4 Trademarks.....	19
5.8 Analog Switch Characteristics.....	9	9.5 Electrostatic Discharge Caution.....	19
5.9 Operating Characteristics.....	10	9.6 Glossary.....	19
5.10 Typical Characteristics.....	10	10 Revision History	20
6 Parameter Measurement Information	11	11 Mechanical, Packaging, and Orderable Information	20
7 Detailed Description	15		

4 Pin Configuration and Functions

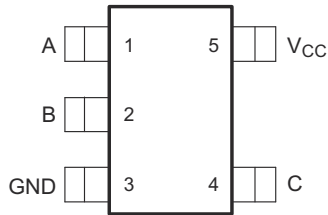

Figure 4-1. DBV Package 5-Pin SOT-23 (Top View)

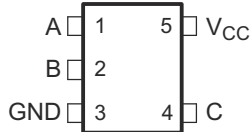

Figure 4-3. DRL Package 5-Pin SOT (Top View)

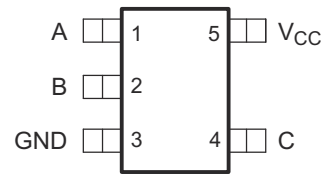

Figure 4-2. DCK Package 5-Pin SC70 (Top View)

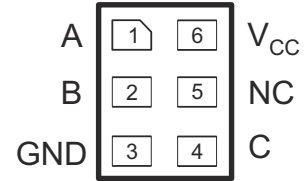

Figure 4-4. DSF Package 6-Pin X2SON (Top View)

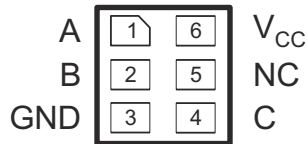

Figure 4-5. DRY Package 6-Pin USON (Top View)

Pin Functions

PIN			Type ⁽¹⁾	DESCRIPTION
NAME	SOT NO.	USON, X2SON NO.		
A	1	1	I/O	Bidirectional signal to be switched
B	2	2	I/O	Bidirectional signal to be switched
C	4	4	I	Controls the switch (L = OFF, H = ON)
GND	3	3	—	Ground pin
NC	—	5	—	Do not connect
V _{CC}	5	6	—	Power pin

(1) I = input; O = output; I/O = input or output

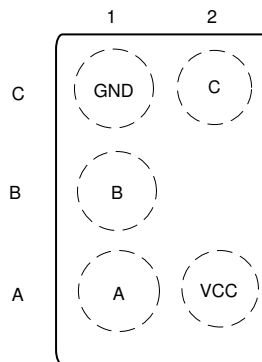

Figure 4-6. YZP Package 5-Pin DSBGA (BottomView)

Pin Functions

PIN		Type ⁽¹⁾	DESCRIPTION
NAME	DSBGA NO.		
A	A1	I/O	Bidirectional signal to be switched
B	B1	I/O	Bidirectional signal to be switched
C	C2	I	Controls the switch (L = OFF, H = ON)
GND	C1	—	Ground pin
V _{CC}	A2	—	Power pin

(1) I = input; O = output; I/O = input or output

5 Specifications

5.1 Absolute Maximum Ratings

over operating free-air temperature range (unless otherwise noted)⁽¹⁾

		MIN	MAX	UNIT	
V _{CC}	DCK, DBV Packages Supply voltage ⁽²⁾	-0.5	6	V	
V _{CC}	DRL, DRY, YZP, DSF Packages Supply voltage ⁽²⁾	-0.5	6.5	V	
V _I	DCK, DBV Packages Input voltage ^{(2) (3)}	-0.5	6	V	
V _I	DRL, DRY, YZP, DSF Packages Input voltage ^{(2) (3)}	-0.5	6.5	V	
V _{I/O}	Switch I/O voltage ^{(2) (3) (4)}	-0.5	V _{CC} + 0.5	V	
I _{IK}	Control input clamp current	V _I < 0		-50	mA
I _{IOK}	I/O port diode current	V _{I/O} < 0 or V _{I/O} > V _{CC}		±50	mA
I _T	ON-state switch current	V _{I/O} < 0 to V _{CC}		±50	mA
	Continuous current through V _{CC} or GND			±100	mA
T _{stg}	Storage Temperature	-65	150	°C	
T _j	Junction Temperature		150	°C	

- (1) Operation outside the *Absolute Maximum Ratings* may cause permanent device damage. *Absolute Maximum Ratings* do not imply functional operation of the device at these or any other conditions beyond those listed under *Recommended Operating Conditions*. If used outside the *Recommended Operating Conditions* but within the *Absolute Maximum Ratings*, the device may not be fully functional, and this may affect device reliability, functionality, performance, and shorten the device lifetime.
- (2) All voltages are with respect to ground, unless otherwise specified.
- (3) The input and output negative-voltage ratings can be exceeded if the input and output clamp-current ratings are observed.
- (4) This value is limited to 5.5V maximum.

5.2 ESD Ratings

		VALUE	UNIT
V _(ESD)	Electrostatic discharge	+2000	V
		+1000	

- (1) JEDEC document JEP155 states that 500V HBM allows safe manufacturing with a standard ESD control process.
- (2) JEDEC document JEP157 states that 250V CDM allows safe manufacturing with a standard ESD control process.

5.3 Recommended Operating Conditions

over operating free-air temperature range (unless otherwise noted)⁽¹⁾

		MIN	MAX	UNIT
V _{CC}	Supply voltage	1.65	5.5	V
V _{I/O}	I/O port voltage.	0	V _{CC}	V
V _{IH}	High-level input voltage, control input	V _{CC} = 1.65V to 1.95V	V _{CC} × 0.65	V
		V _{CC} = 2.3V to 2.7V	V _{CC} × 0.7	
		V _{CC} = 3V to 3.6V	V _{CC} × 0.7	
		V _{CC} = 4.5V to 5.5V	V _{CC} × 0.7	
V _{IL}	Low-level input voltage, control input	V _{CC} = 1.65V to 1.95V	V _{CC} × 0.35	V
		V _{CC} = 2.3V to 2.7V	V _{CC} × 0.3	
		V _{CC} = 3V to 3.6V	V _{CC} × 0.3	
		V _{CC} = 4.5V to 5.5V	V _{CC} × 0.3	
V _I	Control input voltage	0	5.5	V
Δt/Δv	Control input transition rise and fall time	V _{CC} = 1.65V to 1.95V	20	ns/V
		V _{CC} = 2.3V to 2.7V	20	
		V _{CC} = 3V to 3.6V	10	
		V _{CC} = 4.5V to 5.5V	10	
T _A	DCK, DBV Packages Operating free-air temperature	−40	125	°C
T _A	DRL, DRY, YZP, DSF Packages Operating free-air temperature	−40	85	°C

(1) All unused inputs of the device must be held at V_{CC} or GND to provide proper device operation. See also, the [Implications of Slow or Floating CMOS Inputs](#) application note.

5.4 Thermal Information

THERMAL METRIC ⁽¹⁾	SN74LVC1G66						UNIT	
	DBV (SOT-23)	DCK (SC70)	DRL (SOT)	DRY (USON)	DSF (X2SON)	YZP (DSBGA)		
	5 PINS	5 PINS	5 PINS	6 PINS	6 PINS	5 PINS		
R _{θJA}	Junction-to-ambient thermal resistance	262	313	142	355	348	132	°C/W
R _{θJC(top)}	Junction-to-case (top) thermal resistance	198	203	—	250	215	—	°C/W
R _{θJB}	Junction-to-board thermal resistance	142	195	—	222	211	—	°C/W
Ψ _{JT}	Junction-to-top characterization parameter	123	120	—	78	35	—	°C/W
Ψ _{JB}	Junction-to-board characterization parameter	142	194	—	221	210	—	°C/W

(1) For more information about traditional and new thermal metrics, see the [Semiconductor and IC Package Thermal Metrics](#) application note.

5.5 Electrical Characteristics

over recommended operating free-air temperature range (unless otherwise noted)

PARAMETER		TEST CONDITIONS	V _{CC}	MIN	TYP ⁽¹⁾	MAX	UNIT
r _{on}	ON-state switch resistance	V _I = V _{CC} or GND, V _C = V _{IH} (see Figure 6-1 and Figure 5-1)	I _S = 4mA	1.65V	12	30	Ω
			I _S = 8mA	2.3V	9	20	
			I _S = 24mA	3V	7.5	15	
			I _S = 32mA	4.5V	5.5	10	
r _{on(p)}	DCK, DBV Packages Peak on resistance	V _I = V _{CC} to GND, V _C = V _{IH} (see Figure 6-1 and Figure 5-1)	I _S = 4mA	1.65V	125	200	Ω
			I _S = 8mA	2.3V	35	60	
			I _S = 24mA	3V	11.5	25	
			I _S = 32mA	4.5V	7.5	15	
r _{on(p)}	DRL, DRY, YZP, DSF Packages Peak on resistance	V _I = V _{CC} to GND, V _C = V _{IH} (see Figure 6-1 and Figure 5-1)	I _S = 4mA	1.65V	74.5	120	Ω
			I _S = 8mA	2.3V	20	30	
			I _S = 24mA	3V	11.5	25	
			I _S = 32mA	4.5V	7.5	15	
I _{S(off)}	OFF-state switch leakage current	V _I = V _{CC} and V _O = GND or V _I = GND and V _O = V _{CC} , V _C = V _{IL} (see Figure 6-2)	T _A = 25°C	5.5V		±1	μA
				±0.1			
I _{S(on)}	ON-state switch leakage current	V _I = V _{CC} or GND, V _C = V _{IH} , V _O = Open (see Figure 6-3)	T _A = 25°C	5.5V		±1	μA
				±0.1			
I _I	Control input current	V _C = V _{CC} or GND	T _A = 25°C	5.5V		±1	μA
				±0.1			
I _{CC}	Supply current	V _C = V _{CC} or GND	T _A = 25°C	5.5V		10	μA
				1			
ΔI _{CC}	Supply current change	V _C = V _{CC} – 0.6V		5.5V		500	μA
C _{ic}	Control input capacitance			5V		2	pF
C _{io(off)}	Switch input and output capacitance			5V		6	pF
C _{io(on)}	DCK, DBV Packages Switch input and output capacitance			5V		15	pF
C _{io(on)}	DRL, DRY, YZP, DSF Packages Switch input and output capacitance			5V		13	pF

(1) T_A = 25°C

5.6 Switching Characteristics: DBV, DCK

over operating free-air temperature range of T_A = -40 to +125°C

PARAMETER	FROM (INPUT)	TO (OUTPUT)	V _{CC} = 1.8V ± 0.15V		V _{CC} = 2.5V ± 0.2V		V _{CC} = 3.3V ± 0.3V		V _{CC} = 5V ± 0.5V		UNIT
			MIN	MAX	MIN	MAX	MIN	MAX	MIN	MAX	
t _{pd} ⁽¹⁾	A or B	B or A		2.2		1.2		0.8		0.6	ns
t _{en} ⁽²⁾	C	A or B	2.5	12	1.9	6.5	1.8	5	1.5	4.2	ns
t _{dis} ⁽³⁾	C	A or B	2.2	11.5	1.4	6.9	2	6.5	1.4	6	ns

(1) t_{PLH} and t_{PHL} are the same as t_{pd}. The propagation delay is the calculated RC time constant of the typical ON-state resistance of the switch and the specified load capacitance, when driven by an ideal voltage source (zero output impedance).

(2) t_{PZL} and t_{PZH} are the same as t_{en}.

(3) t_{PLZ} and t_{PHZ} are the same as t_{dis}.

5.7 Switching Characteristics: DRL, DRY, YZP, DSF

over operating free-air temperature range of $T_A = -40$ to $+85^\circ\text{C}$

PARAMETER	FROM (INPUT)	TO (OUTPUT)	$V_{CC} = 1.8\text{V}$ $\pm 0.15\text{V}$		$V_{CC} = 2.5\text{V}$ $\pm 0.2\text{V}$		$V_{CC} = 3.3\text{V}$ $\pm 0.3\text{V}$		$V_{CC} = 5\text{V}$ $\pm 0.5\text{V}$		UNIT
			MIN	MAX	MIN	MAX	MIN	MAX	MIN	MAX	
$t_{pd}^{(1)}$	A or B	B or A		2		1.2		0.8		0.6	ns
$t_{en}^{(2)}$	C	A or B	2.5	12	1.9	6.5	1.8	5	1.5	4.2	ns
$t_{dis}^{(3)}$	C	A or B	2.2	10	1.4	6.9	2	6.5	1.4	5	ns

5.8 Analog Switch Characteristics

T_A = 25°C

PARAMETER	FROM (INPUT)	TO (OUTPUT)	TEST CONDITIONS	V _{CC}	TYP	UNIT
Frequency response ⁽¹⁾ (switch ON)	A or B	B or A	C _L = 50pF, R _L = 600Ω, f _{in} = sine wave (see Figure 6-5)	1.65V	35	MHz
				2.3V	120	
				3V	175	
				4.5V	195	
			C _L = 5pF, R _L = 50Ω, f _{in} = sine wave (see Figure 6-5)	1.65V	>300	
				2.3V	>300	
				3V	>300	
				4.5V	>300	
Crosstalk (control input to signal output)	C	A or B	C _L = 50pF, R _L = 600Ω, f _{in} = 1MHz (square wave) (see Figure 6-6)	1.65V	35	mV
				2.3V	50	
				3V	70	
				4.5V	100	
Feedthrough attenuation ⁽²⁾ (switch OFF)	A or B	B or A	C _L = 50pF, R _L = 600Ω, f _{in} = 1MHz (sine wave) (see Figure 6-7)	1.65V	-58	dB
				2.3V	-58	
				3V	-58	
				4.5V	-58	
			C _L = 5pF, R _L = 50Ω, f _{in} = 1MHz (sine wave) (see Figure 6-7)	1.65V	-42	
				2.3V	-42	
				3V	-42	
				4.5V	-42	
DCK, DBV Packages Sine-wave distortion	A or B	B or A	C _L = 50pF, R _L = 10kΩ, f _{in} = 1kHz (sine wave) (see Figure 6-8)	1.65V	0.5	%
				2.3V	0.025	
				3V	0.015	
				4.5V	0.01	
			C _L = 50pF, R _L = 10kΩ, f _{in} = 10kHz (sine wave) (see Figure 6-8)	1.65V	0.15	
				2.3V	0.025	
				3V	0.015	
				4.5V	0.01	
DRL, DRY, YZP, DSF Packages Sine-wave distortion	A or B	B or A	C _L = 50pF, R _L = 10kΩ, f _{in} = 1kHz (sine wave) (see Figure 6-8)	1.65V	0.1	%
				2.3V	0.025	
				3V	0.015	
				4.5V	0.01	
			C _L = 50pF, R _L = 10kΩ, f _{in} = 10kHz (sine wave) (see Figure 6-8)	1.65V	0.15	
				2.3V	0.025	
				3V	0.015	
				4.5V	0.01	

- (1) Adjust f_{in} voltage to obtain 0dBm at output. Increase f_{in} frequency until dB meter reads -3dB.
(2) Adjust f_{in} voltage to obtain 0dBm at input.

5.9 Operating Characteristics

$T_A = 25^\circ\text{C}$

PARAMETER	TEST CONDITIONS	$V_{CC} = 1.8\text{V}$	$V_{CC} = 2.5\text{V}$	$V_{CC} = 3.3\text{V}$	$V_{CC} = 5\text{V}$	UNIT
		TYP	TYP	TYP	TYP	
C_{pd} Power dissipation capacitance	$f = 10\text{MHz}$	8	9	9	11	pF

5.10 Typical Characteristics

$T_A = 25^\circ\text{C}$

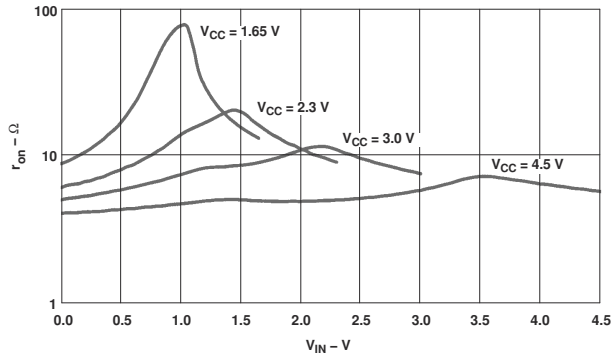

Figure 5-1. Typical r_{on} as a Function of Input Voltage (V_I) for $V_I = 0$ to V_{CC}

6 Parameter Measurement Information

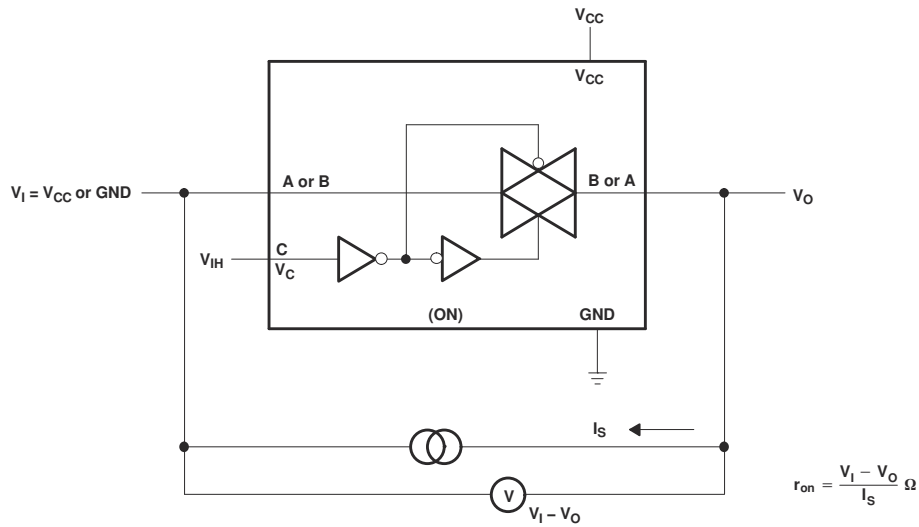

Figure 6-1. ON-State Resistance Test Circuit

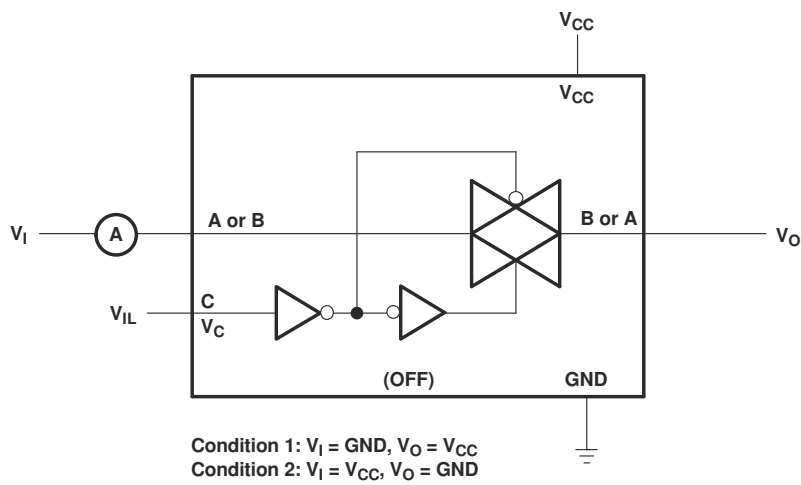

Figure 6-2. OFF-State Switch Leakage-Current Test Circuit

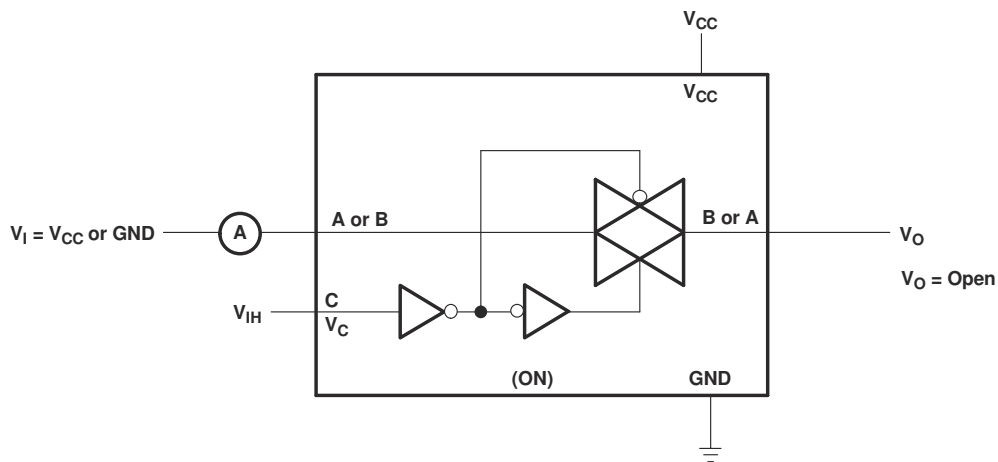
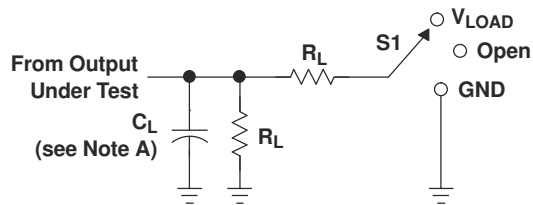

Figure 6-3. ON-State Switch Leakage-Current Test Circuit



TEST	S1
t_{PLH}/t_{PHL}	Open
t_{PLZ}/t_{PZL}	V_{LOAD}
t_{PHZ}/t_{PZH}	GND

LOAD CIRCUIT

V_{CC}	INPUTS		V_M	V_{LOAD}	C_L	R_L	V_{Δ}
	V_I	t_r/t_f					
$1.8\text{ V} \pm 0.15\text{ V}$	V_{CC}	$\leq 2\text{ ns}$	$V_{CC}/2$	$2 \times V_{CC}$	30 pF	1 k Ω	0.15 V
$2.5\text{ V} \pm 0.2\text{ V}$	V_{CC}	$\leq 2\text{ ns}$	$V_{CC}/2$	$2 \times V_{CC}$	30 pF	500 Ω	0.15 V
$3.3\text{ V} \pm 0.3\text{ V}$	V_{CC}	$\leq 2.5\text{ ns}$	$V_{CC}/2$	$2 \times V_{CC}$	50 pF	500 Ω	0.3 V
$5\text{ V} \pm 0.5\text{ V}$	V_{CC}	$\leq 2.5\text{ ns}$	$V_{CC}/2$	$2 \times V_{CC}$	50 pF	500 Ω	0.3 V

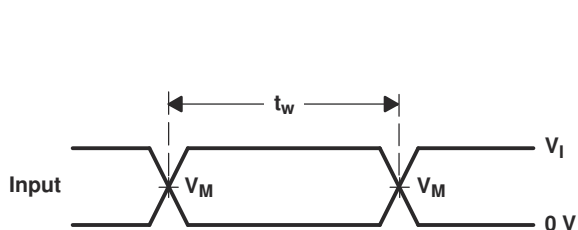

VOLTAGE WAVEFORMS
PULSE DURATION

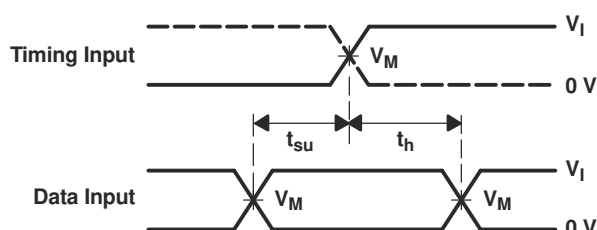

VOLTAGE WAVEFORMS
SETUP AND HOLD TIMES

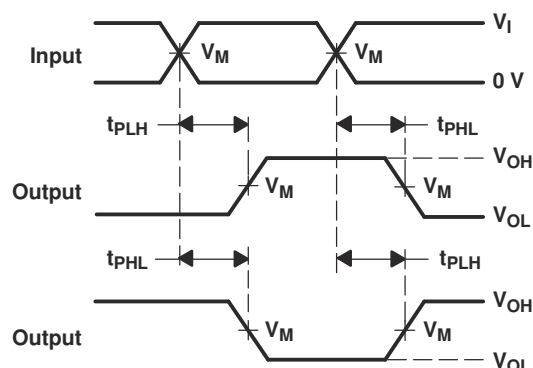

VOLTAGE WAVEFORMS
PROPAGATION DELAY TIMES
INVERTING AND NONINVERTING OUTPUTS

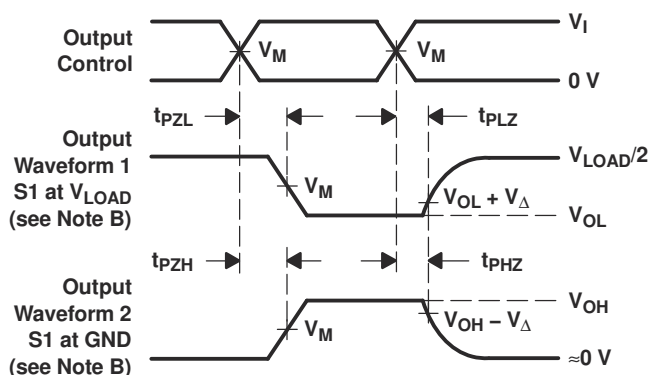

VOLTAGE WAVEFORMS
ENABLE AND DISABLE TIMES
LOW- AND HIGH-LEVEL ENABLING

- NOTES: A. C_L includes probe and jig capacitance.
 B. Waveform 1 is for an output with internal conditions such that the output is low, except when disabled by the output control. Waveform 2 is for an output with internal conditions such that the output is high, except when disabled by the output control.
 C. All input pulses are supplied by generators having the following characteristics: $PRR \leq 10\text{ MHz}$, $Z_O = 50\ \Omega$.
 D. The outputs are measured one at a time, with one transition per measurement.
 E. t_{PLZ} and t_{PHZ} are the same as t_{dis} .
 F. t_{PZL} and t_{PZH} are the same as t_{en} .
 G. t_{PLH} and t_{PHL} are the same as t_{pd} .
 H. All parameters and waveforms are not applicable to all devices.

Figure 6-4. Load Circuit and Voltage Waveforms

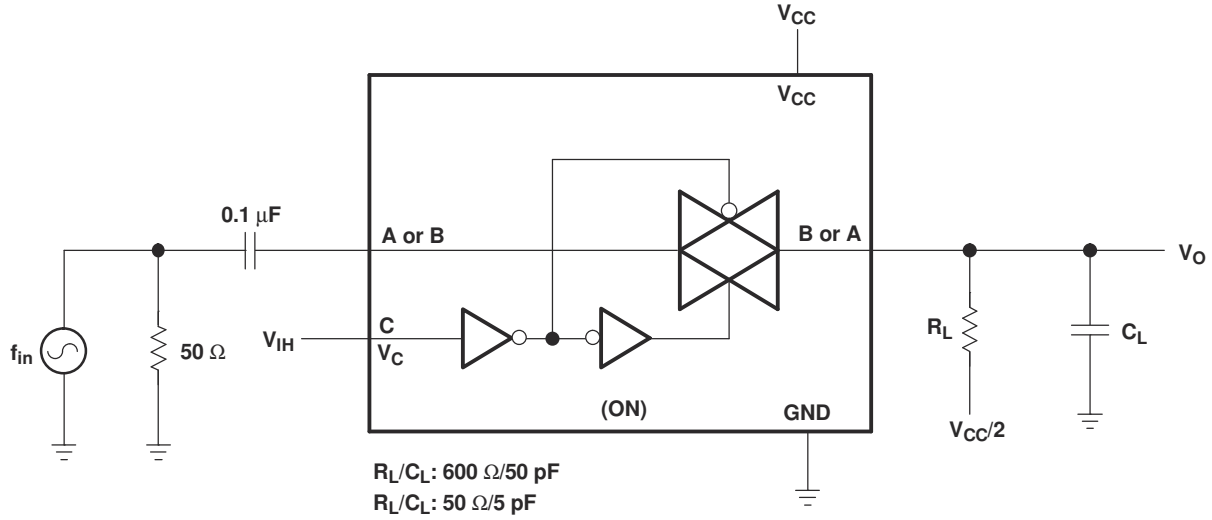

Figure 6-5. Frequency Response (Switch ON)

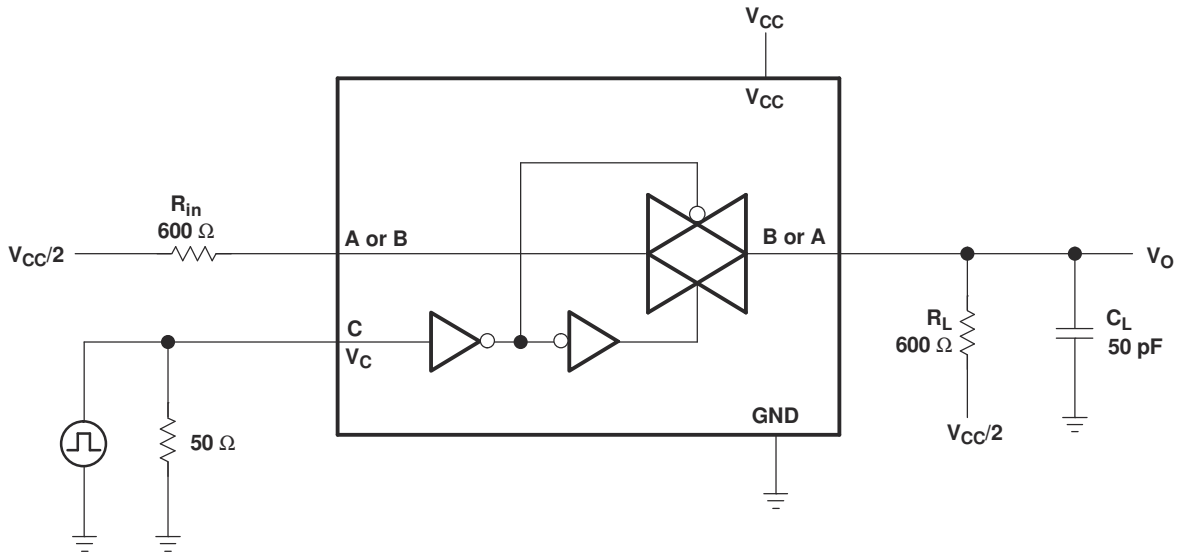

Figure 6-6. Crosstalk (Control Input – Switch Output)

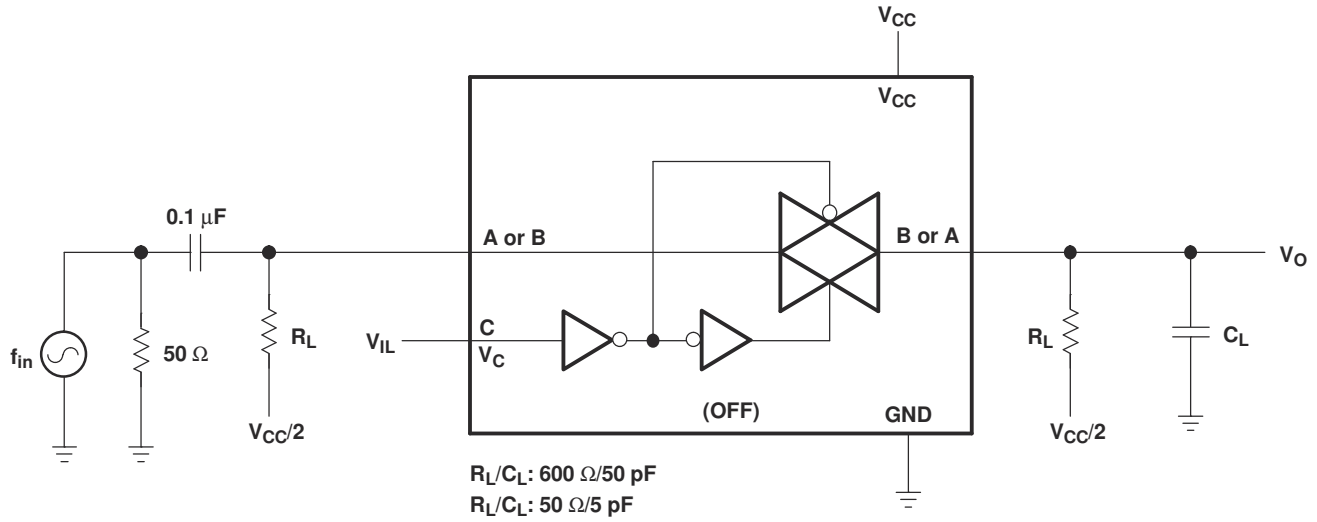

Figure 6-7. Feedthrough (Switch OFF)

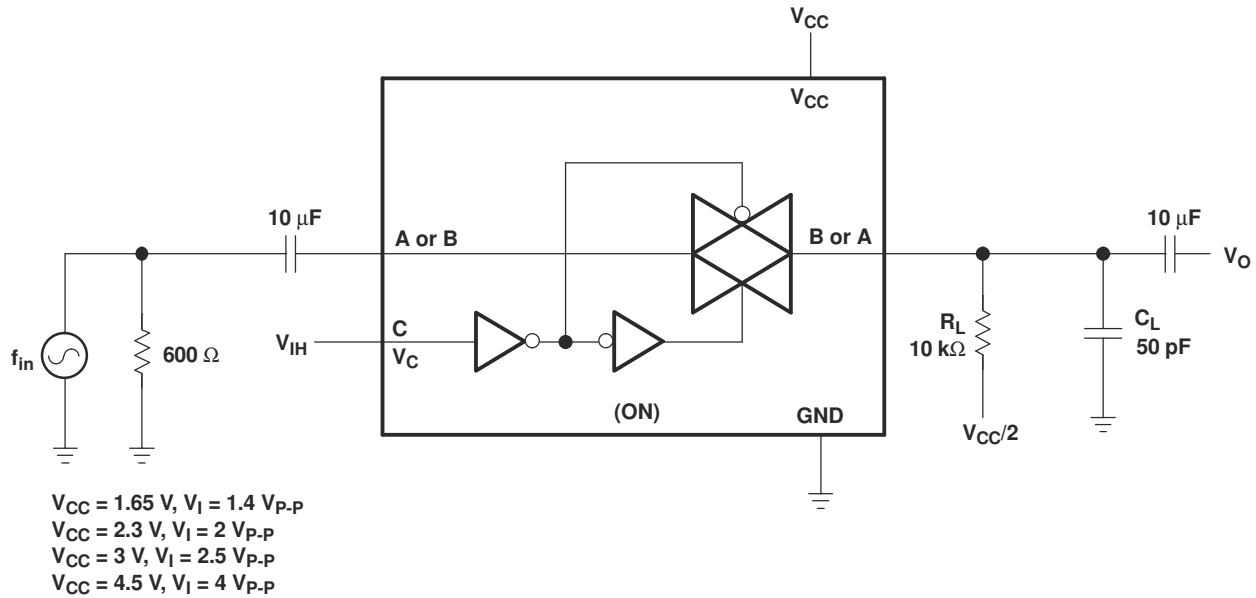

Figure 6-8. Sine-Wave Distortion

7 Detailed Description

7.1 Overview

The SN74LVC1G66 single, bilateral analog switch is designed for 1.65V to 5.5V V_{CC} operation, and supports both analog and digital signals. SN74LVC1G66 permits bidirectional transmission of signals with amplitudes of up to 5.5V (peak). By using the die as the package, NanoFree package technology represents a significant advancement in IC packaging concepts.

7.2 Functional Block Diagram

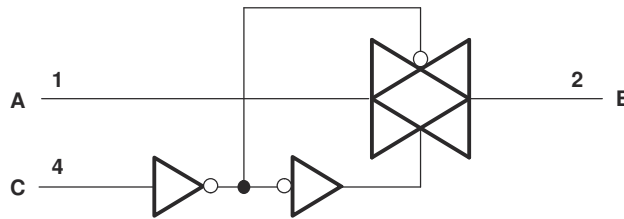

Logic Diagram (Positive Logic)

7.3 Feature Description

The TI NanoFree package is one of TI's smallest packages, which enables customers to save board space. The solder bumps enable easy testing. The SN74LVC1G66 has a wide V_{CC} range, enabling rail-to-rail operation of signals anywhere from a 1.8V to a 5V system. In addition, the control input (C Pin) tolerates up to 5.5V, enabling higher-voltage logic to interface to the switch control system.

7.4 Device Functional Modes

Table 7-1. Function Table

CONTROL INPUT (C)	SWITCH
L	OFF
H	ON

8 Application and Implementation

Note

Information in the following applications sections is not part of the TI component specification, and TI does not warrant its accuracy or completeness. TI's customers are responsible for determining suitability of components for their purposes. Customers should validate and test their design implementation to confirm system functionality.

8.1 Application Information

The SN74LVC1G66 can be used in any application where an SPST switch is used and a solid-state, voltage-controlled version is preferred.

8.2 Typical Application

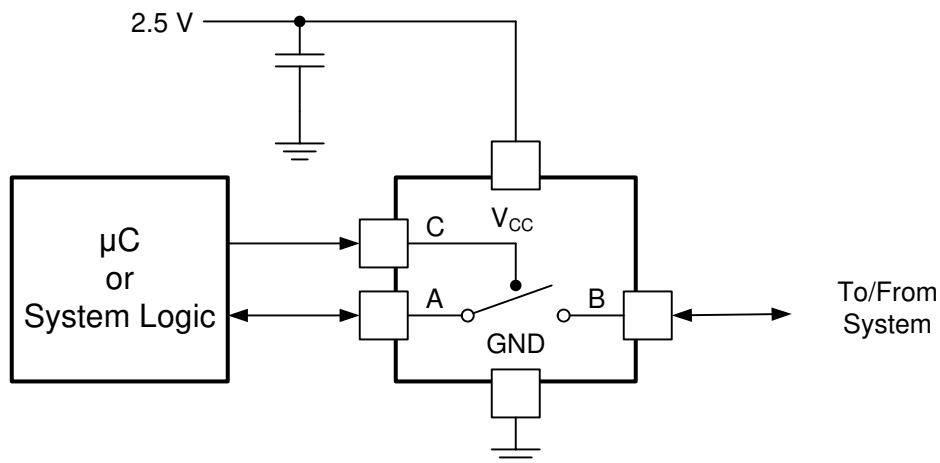

Figure 8-1. Typical Application Schematic

8.2.1 Design Requirements

The SN74LVC1G66 enables on and off control of analog and digital signals with a digital control signal. All input signals must remain between 0V and V_{CC} for optimal operation.

8.2.2 Detailed Design Procedure

1. Recommended Input Conditions:
 - For rise time and fall time specifications, see $\Delta t/\Delta v$ in [Section 5.3](#).
 - For specified high and low levels, see V_{IH} and V_{IL} in [Section 5.3](#).
 - Inputs and outputs are overvoltage tolerant allowing them to go as high as 5.5V at any valid V_{CC} .
2. Recommended Output Conditions:
 - Load currents must not exceed $\pm 50\text{mA}$.
3. Frequency Selection Criterion:
 - Maximum frequency tested is 150MHz.
 - Added trace resistance/capacitance can reduce maximum frequency capability; use layout practices as directed in [Section 8.4](#).

8.2.3 Application Curve

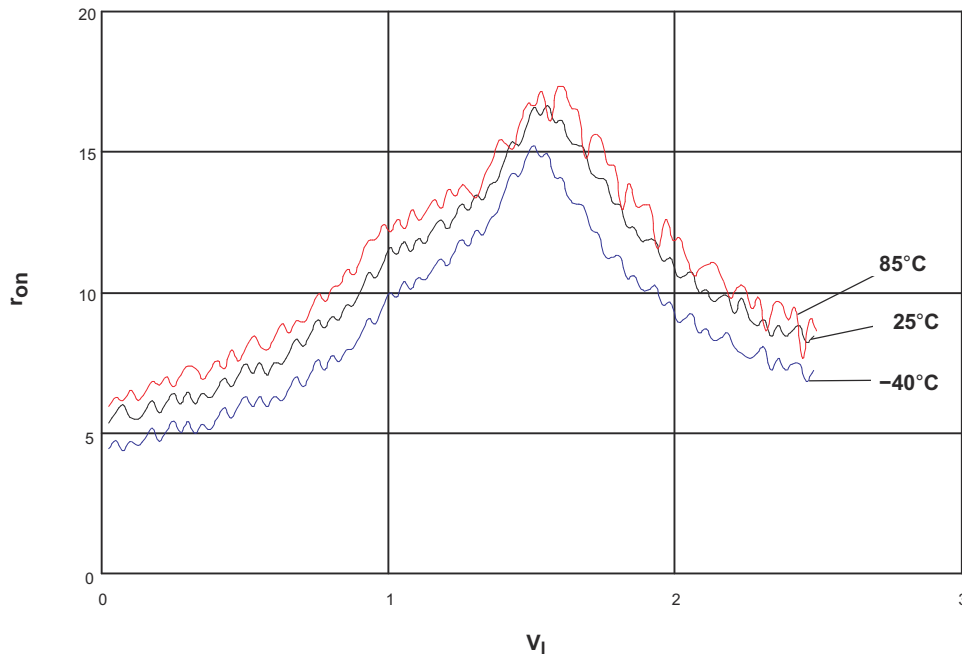

Figure 8-2. r_{on} vs V_I , $V_{CC} = 2.5V$ (SN74LVC1G66)

8.3 Power Supply Recommendations

The power supply can be any voltage between the minimum and maximum supply voltage rating located in [Section 5.3](#).

Each V_{CC} terminal must have a bypass capacitor to prevent power disturbance. For devices with a single supply, a $0.1\mu F$ bypass capacitor is recommended. If there are multiple pins labeled V_{CC} , then a $0.01\mu F$ or $0.022\mu F$ capacitor is recommended for each V_{CC} because the V_{CC} pins are connected internally. For devices with dual supply pins operating at different voltages (for example V_{CC} and V_{DD}), a $0.1\mu F$ bypass capacitor is recommended for each supply pin. Having parallel multiple bypass capacitors is acceptable to reject different frequencies of noise. $0.1\mu F$ and $1\mu F$ capacitors are commonly used in parallel. The bypass capacitor must be installed as close to the power terminal as possible for best results.

8.4 Layout

8.4.1 Layout Guidelines

Reflections and matching are closely related to loop antenna theory, but different enough to warrant a separate discussion. When a PCB trace turns a corner at a 90 degree angle, a reflection can occur. This occurs primarily due to the change of width of the trace. At the apex of the turn, the trace width is increased to 1.414 times the width. This upsets the transmission line characteristics — especially the distributed capacitance and self-inductance of the trace — resulting in the reflection.

Note

Not all PCB traces can be straight, and so can require turning corners. [Figure 8-3](#) shows progressively better techniques of rounding corners. Only the last example maintains constant trace width and minimizes reflections.

8.4.2 Layout Example

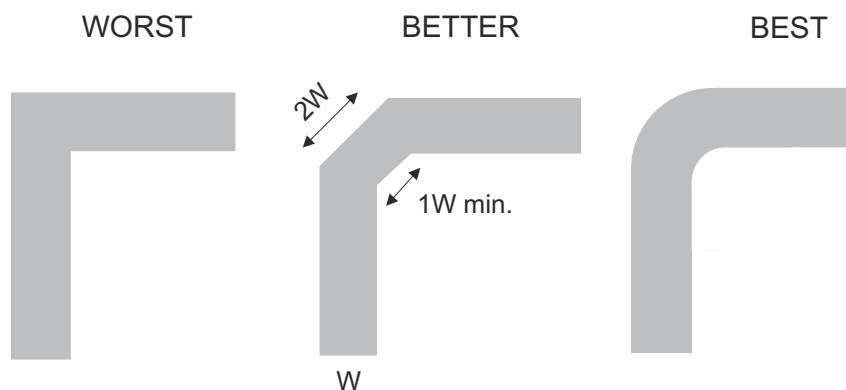

Figure 8-3. Trace Example

9 Device and Documentation Support

9.1 Documentation Support

9.1.1 Related Documentation

- Texas Instruments, [Implications of Slow or Floating CMOS Inputs](#)

9.2 Receiving Notification of Documentation Updates

To receive notification of documentation updates, navigate to the device product folder on [ti.com](#). Click on *Notifications* to register and receive a weekly digest of any product information that has changed. For change details, review the revision history included in any revised document.

9.3 Support Resources

[TI E2E™ support forums](#) are an engineer's go-to source for fast, verified answers and design help — straight from the experts. Search existing answers or ask your own question to get the quick design help you need.

Linked content is provided "AS IS" by the respective contributors. They do not constitute TI specifications and do not necessarily reflect TI's views; see TI's [Terms of Use](#).

9.4 Trademarks

NanoFree™ and TI E2E™ are trademarks of Texas Instruments.
All trademarks are the property of their respective owners.

9.5 Electrostatic Discharge Caution



This integrated circuit can be damaged by ESD. Texas Instruments recommends that all integrated circuits be handled with appropriate precautions. Failure to observe proper handling and installation procedures can cause damage.

ESD damage can range from subtle performance degradation to complete device failure. Precision integrated circuits may be more susceptible to damage because very small parametric changes could cause the device not to meet its published specifications.

9.6 Glossary

[TI Glossary](#) This glossary lists and explains terms, acronyms, and definitions.

10 Revision History

NOTE: Page numbers for previous revisions may differ from page numbers in the current version.

Changes from Revision Q (March 2017) to Revision R (September 2025)	Page
• Updated the numbering format for tables, figures, and cross-references throughout the document.....	1
• Updated Thermal Information.....	6
• Updated resistance range in Section 5.5	7
• Updated switching timing in Section 5.6	7
• Updated Sine-wave distortion in Section 5.8	9
• Added <i>Receiving Notifications of Documentation Updates</i> , <i>Support Resources</i> , <i>Electrostatic Discharge Caution</i> , and <i>Glossary</i> the sections.....	19

Changes from Revision P (March 2016) to Revision Q (March 2017)	Page
• Changed the YZP package pin out graphic.....	4

Changes from Revision O (March 2015) to Revision P (March 2016)	Page
• Added Junction temperature specification to <i>Absolute Maximum Ratings</i> table.....	5
• Added "Control" to "Input transition rise and fall time" in <i>Recommended Operating Conditions</i> table.....	6

Changes from Revision N (December 2012) to Revision O (March 2015)	Page
• Added <i>Pin Configuration and Functions</i> section, <i>ESD Ratings</i> table, <i>Feature Description</i> section, <i>Device Functional Modes</i> , <i>Application and Implementation</i> section, <i>Power Supply Recommendations</i> section, <i>Layout</i> section, <i>Device and Documentation Support</i> section, and <i>Mechanical, Packaging, and Orderable Information</i> section.....	1
• Removed <i>Ordering Information</i> table.....	1
• Added <i>Device Information</i> table.....	1

Changes from Revision M (January 2012) to Revision N (December 2012)	Page
• Added jumbo reel to <i>Ordering Information</i> table.....	1

Changes from Revision L (January 2007) to Revision M (January 2012)	Page
• Added DSF and DRY package to pin out graphic.....	3

11 Mechanical, Packaging, and Orderable Information

The following pages include mechanical, packaging, and orderable information. This information is the most current data available for the designated devices. This data is subject to change without notice and revision of this document. For browser-based versions of this data sheet, refer to the left-hand navigation.

PACKAGING INFORMATION

Orderable part number	Status (1)	Material type (2)	Package Pins	Package qty Carrier	RoHS (3)	Lead finish/ Ball material (4)	MSL rating/ Peak reflow (5)	Op temp (°C)	Part marking (6)
SN74LVC1G66DBVR	Active	Production	SOT-23 (DBV) 5	3000 LARGE T&R	Yes	NIPDAU SN	Level-1-260C-UNLIM	-40 to 85	(C665, C66J, C66R, C66T)
SN74LVC1G66DBVR.A	Active	Production	SOT-23 (DBV) 5	3000 LARGE T&R	Yes	SN	Level-1-260C-UNLIM	-40 to 85	(C665, C66J, C66R, C66T)
SN74LVC1G66DBVR.B	Active	Production	SOT-23 (DBV) 5	3000 LARGE T&R	Yes	SN	Level-1-260C-UNLIM	-40 to 85	(C665, C66J, C66R, C66T)
SN74LVC1G66DCKR	Active	Production	SC70 (DCK) 5	3000 LARGE T&R	Yes	NIPDAU SN	Level-1-260C-UNLIM	-40 to 85	(C65, C6F, C6J, C6K, C6O, C6R, C6T)
SN74LVC1G66DCKR.A	Active	Production	SC70 (DCK) 5	3000 LARGE T&R	Yes	NIPDAU	Level-1-260C-UNLIM	-40 to 85	(C65, C6F, C6J, C6K, C6O, C6R, C6T)
SN74LVC1G66DCKR.B	Active	Production	SC70 (DCK) 5	3000 LARGE T&R	Yes	NIPDAU	Level-1-260C-UNLIM	-40 to 85	(C65, C6F, C6J, C6K, C6O, C6R, C6T)
SN74LVC1G66DRLR	Active	Production	SOT-5X3 (DRL) 5	4000 LARGE T&R	Yes	NIPDAUAG	Level-1-260C-UNLIM	-40 to 85	(C67, C6R)
SN74LVC1G66DRLR.A	Active	Production	SOT-5X3 (DRL) 5	4000 LARGE T&R	Yes	NIPDAUAG	Level-1-260C-UNLIM	-40 to 85	(C67, C6R)
SN74LVC1G66DRLR.B	Active	Production	SOT-5X3 (DRL) 5	4000 LARGE T&R	Yes	NIPDAUAG	Level-1-260C-UNLIM	-40 to 85	(C67, C6R)
SN74LVC1G66DRYR	Active	Production	SON (DRY) 6	5000 LARGE T&R	Yes	NIPDAU	Level-1-260C-UNLIM	-40 to 85	C6
SN74LVC1G66DRYR.A	Active	Production	SON (DRY) 6	5000 LARGE T&R	Yes	NIPDAU	Level-1-260C-UNLIM	-40 to 85	C6
SN74LVC1G66DRYR.B	Active	Production	SON (DRY) 6	5000 LARGE T&R	Yes	NIPDAU	Level-1-260C-UNLIM	-40 to 85	C6
SN74LVC1G66DSFR	Active	Production	SON (DSF) 6	5000 LARGE T&R	Yes	NIPDAU	Level-1-260C-UNLIM	-40 to 85	C6
SN74LVC1G66DSFR.A	Active	Production	SON (DSF) 6	5000 LARGE T&R	Yes	NIPDAU	Level-1-260C-UNLIM	-40 to 85	C6
SN74LVC1G66DSFR.B	Active	Production	SON (DSF) 6	5000 LARGE T&R	Yes	NIPDAU	Level-1-260C-UNLIM	-40 to 85	C6
SN74LVC1G66YZPR	Active	Production	DSBGA (YZP) 5	3000 LARGE T&R	Yes	SNAGCU	Level-1-260C-UNLIM	-40 to 85	C6N
SN74LVC1G66YZPR.B	Active	Production	DSBGA (YZP) 5	3000 LARGE T&R	Yes	SNAGCU	Level-1-260C-UNLIM	-40 to 85	C6N

(1) **Status:** For more details on status, see our [product life cycle](#).

(2) **Material type:** When designated, preproduction parts are prototypes/experimental devices, and are not yet approved or released for full production. Testing and final process, including without limitation quality assurance, reliability performance testing, and/or process qualification, may not yet be complete, and this item is subject to further changes or possible discontinuation. If available for ordering, purchases will be subject to an additional waiver at checkout, and are intended for early internal evaluation purposes only. These items are sold without warranties of any kind.

(3) **RoHS values:** Yes, No, RoHS Exempt. See the [TI RoHS Statement](#) for additional information and value definition.

(4) **Lead finish/Ball material:** Parts may have multiple material finish options. Finish options are separated by a vertical ruled line. Lead finish/Ball material values may wrap to two lines if the finish value exceeds the maximum column width.

(5) **MSL rating/Peak reflow:** The moisture sensitivity level ratings and peak solder (reflow) temperatures. In the event that a part has multiple moisture sensitivity ratings, only the lowest level per JEDEC standards is shown. Refer to the shipping label for the actual reflow temperature that will be used to mount the part to the printed circuit board.

(6) **Part marking:** There may be an additional marking, which relates to the logo, the lot trace code information, or the environmental category of the part.

Multiple part markings will be inside parentheses. Only one part marking contained in parentheses and separated by a "~" will appear on a part. If a line is indented then it is a continuation of the previous line and the two combined represent the entire part marking for that device.

Important Information and Disclaimer:The information provided on this page represents TI's knowledge and belief as of the date that it is provided. TI bases its knowledge and belief on information provided by third parties, and makes no representation or warranty as to the accuracy of such information. Efforts are underway to better integrate information from third parties. TI has taken and continues to take reasonable steps to provide representative and accurate information but may not have conducted destructive testing or chemical analysis on incoming materials and chemicals. TI and TI suppliers consider certain information to be proprietary, and thus CAS numbers and other limited information may not be available for release.

In no event shall TI's liability arising out of such information exceed the total purchase price of the TI part(s) at issue in this document sold by TI to Customer on an annual basis.

OTHER QUALIFIED VERSIONS OF SN74LVC1G66 :

- Automotive : [SN74LVC1G66-Q1](#)

NOTE: Qualified Version Definitions:

- Automotive - Q100 devices qualified for high-reliability automotive applications targeting zero defects

TAPE AND REEL INFORMATION

QUADRANT ASSIGNMENTS FOR PIN 1 ORIENTATION IN TAPE

*All dimensions are nominal

Device	Package Type	Package Drawing	Pins	SPQ	Reel Diameter (mm)	Reel Width W1 (mm)	A0 (mm)	B0 (mm)	K0 (mm)	P1 (mm)	W (mm)	Pin1 Quadrant
SN74LVC1G66DBVR	SOT-23	DBV	5	3000	178.0	9.0	3.3	3.2	1.4	4.0	8.0	Q3
SN74LVC1G66DBVR	SOT-23	DBV	5	3000	178.0	8.4	3.2	3.2	1.4	4.0	8.0	Q3
SN74LVC1G66DBVR	SOT-23	DBV	5	3000	180.0	8.4	3.23	3.17	1.37	4.0	8.0	Q3
SN74LVC1G66DCKR	SC70	DCK	5	3000	178.0	9.0	2.4	2.5	1.2	4.0	8.0	Q3
SN74LVC1G66DCKR	SC70	DCK	5	3000	180.0	8.4	2.47	2.3	1.25	4.0	8.0	Q3
SN74LVC1G66DRLR	SOT-5X3	DRL	5	4000	180.0	8.4	1.98	1.78	0.69	4.0	8.0	Q3
SN74LVC1G66DRYR	SON	DRY	6	5000	180.0	9.5	1.15	1.6	0.75	4.0	8.0	Q1
SN74LVC1G66DSFR	SON	DSF	6	5000	180.0	8.4	1.16	1.16	0.5	4.0	8.0	Q2
SN74LVC1G66YZPR	DSBGA	YZP	5	3000	178.0	9.2	1.02	1.52	0.63	4.0	8.0	Q1

TAPE AND REEL BOX DIMENSIONS

*All dimensions are nominal

Device	Package Type	Package Drawing	Pins	SPQ	Length (mm)	Width (mm)	Height (mm)
SN74LVC1G66DBVR	SOT-23	DBV	5	3000	180.0	180.0	18.0
SN74LVC1G66DBVR	SOT-23	DBV	5	3000	208.0	191.0	35.0
SN74LVC1G66DBVR	SOT-23	DBV	5	3000	202.0	201.0	28.0
SN74LVC1G66DCKR	SC70	DCK	5	3000	180.0	180.0	18.0
SN74LVC1G66DCKR	SC70	DCK	5	3000	202.0	201.0	28.0
SN74LVC1G66DRLR	SOT-5X3	DRL	5	4000	202.0	201.0	28.0
SN74LVC1G66DRYR	SON	DRY	6	5000	184.0	184.0	19.0
SN74LVC1G66DSFR	SON	DSF	6	5000	210.0	185.0	35.0
SN74LVC1G66YZPR	DSBGA	YZP	5	3000	220.0	220.0	35.0

EXAMPLE BOARD LAYOUT

DBV0005A

SOT-23 - 1.45 mm max height

SMALL OUTLINE TRANSISTOR



LAND PATTERN EXAMPLE
EXPOSED METAL SHOWN
SCALE:15X



SOLDER MASK DETAILS

4214839/K 08/2024

NOTES: (continued)

- 6. Publication IPC-7351 may have alternate designs.
- 7. Solder mask tolerances between and around signal pads can vary based on board fabrication site.

EXAMPLE STENCIL DESIGN

DBV0005A

SOT-23 - 1.45 mm max height

SMALL OUTLINE TRANSISTOR



SOLDER PASTE EXAMPLE
BASED ON 0.125 mm THICK STENCIL
SCALE:15X

4214839/K 08/2024

NOTES: (continued)

8. Laser cutting apertures with trapezoidal walls and rounded corners may offer better paste release. IPC-7525 may have alternate design recommendations.
9. Board assembly site may have different recommendations for stencil design.

GENERIC PACKAGE VIEW

DRY 6

USON - 0.6 mm max height

PLASTIC SMALL OUTLINE - NO LEAD



Images above are just a representation of the package family, actual package may vary.
Refer to the product data sheet for package details.

4207181/G

DRY0006A



PACKAGE OUTLINE

USON - 0.6 mm max height

PLASTIC SMALL OUTLINE - NO LEAD

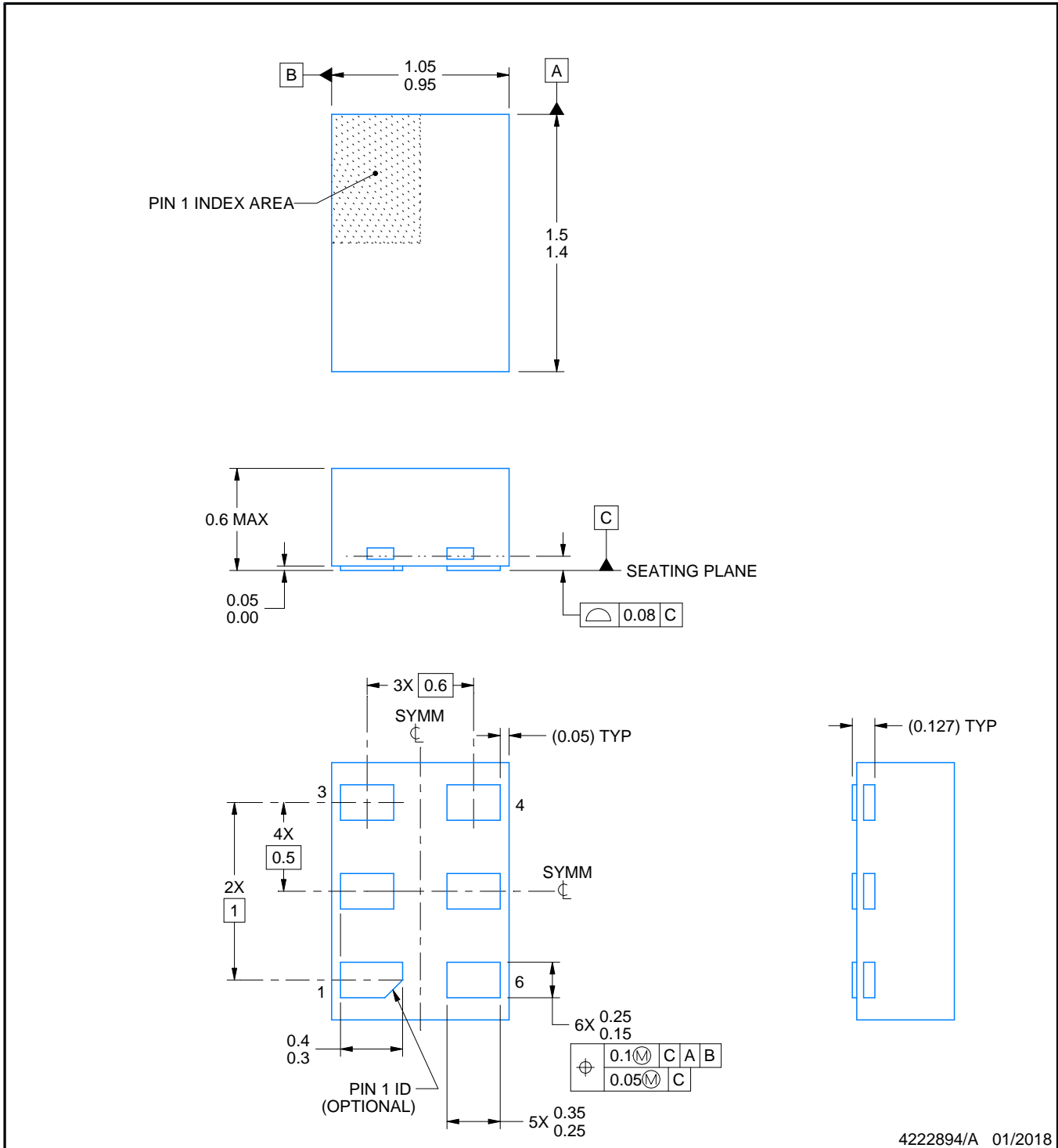

NOTES:

1. All linear dimensions are in millimeters. Any dimensions in parenthesis are for reference only. Dimensioning and tolerancing per ASME Y14.5M.
2. This drawing is subject to change without notice.

EXAMPLE BOARD LAYOUT

DRY0006A

USON - 0.6 mm max height

PLASTIC SMALL OUTLINE - NO LEAD



LAND PATTERN EXAMPLE
1:1 RATIO WITH PKG SOLDER PADS
EXPOSED METAL SHOWN
SCALE:40X



SOLDER MASK DETAILS

4222894/A 01/2018

NOTES: (continued)

3. For more information, see QFN/SON PCB application report in literature No. SLUA271 (www.ti.com/lit/sluea271).

EXAMPLE STENCIL DESIGN

DRY0006A

USON - 0.6 mm max height

PLASTIC SMALL OUTLINE - NO LEAD

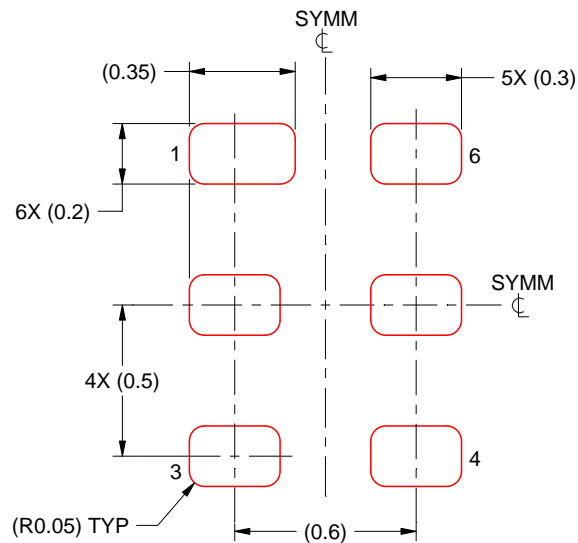

SOLDER PASTE EXAMPLE
BASED ON 0.075 - 0.1 mm THICK STENCIL
SCALE:40X

4222894/A 01/2018

NOTES: (continued)

4. Laser cutting apertures with trapezoidal walls and rounded corners may offer better paste release. IPC-7525 may have alternate design recommendations.



DSF0006A

PACKAGE OUTLINE

X2SON - 0.4 mm max height

PLASTIC SMALL OUTLINE - NO LEAD



NOTES:

1. All linear dimensions are in millimeters. Any dimensions in parenthesis are for reference only. Dimensioning and tolerancing per ASME Y14.5M.
2. This drawing is subject to change without notice.
3. Reference JEDEC registration MO-287, variation X2AAF.

EXAMPLE BOARD LAYOUT

DSF0006A

X2SON - 0.4 mm max height

PLASTIC SMALL OUTLINE - NO LEAD



LAND PATTERN EXAMPLE
EXPOSED METAL SHOWN
SCALE:40X



SOLDER MASK DETAILS

4220597/B 06/2022

NOTES: (continued)

4. For more information, see Texas Instruments literature number SLUA271 (www.ti.com/lit/slua271).

EXAMPLE STENCIL DESIGN

DSF0006A

X2SON - 0.4 mm max height

PLASTIC SMALL OUTLINE - NO LEAD



SOLDER PASTE EXAMPLE
BASED ON 0.09 mm THICK STENCIL

PRINTED SOLDER COVERAGE BY AREA UNDER PACKAGE
SCALE:40X

4220597/B 06/2022

4. Laser cutting apertures with trapezoidal walls and rounded corners may offer better paste release. IPC-7525 may have alternate design recommendations.

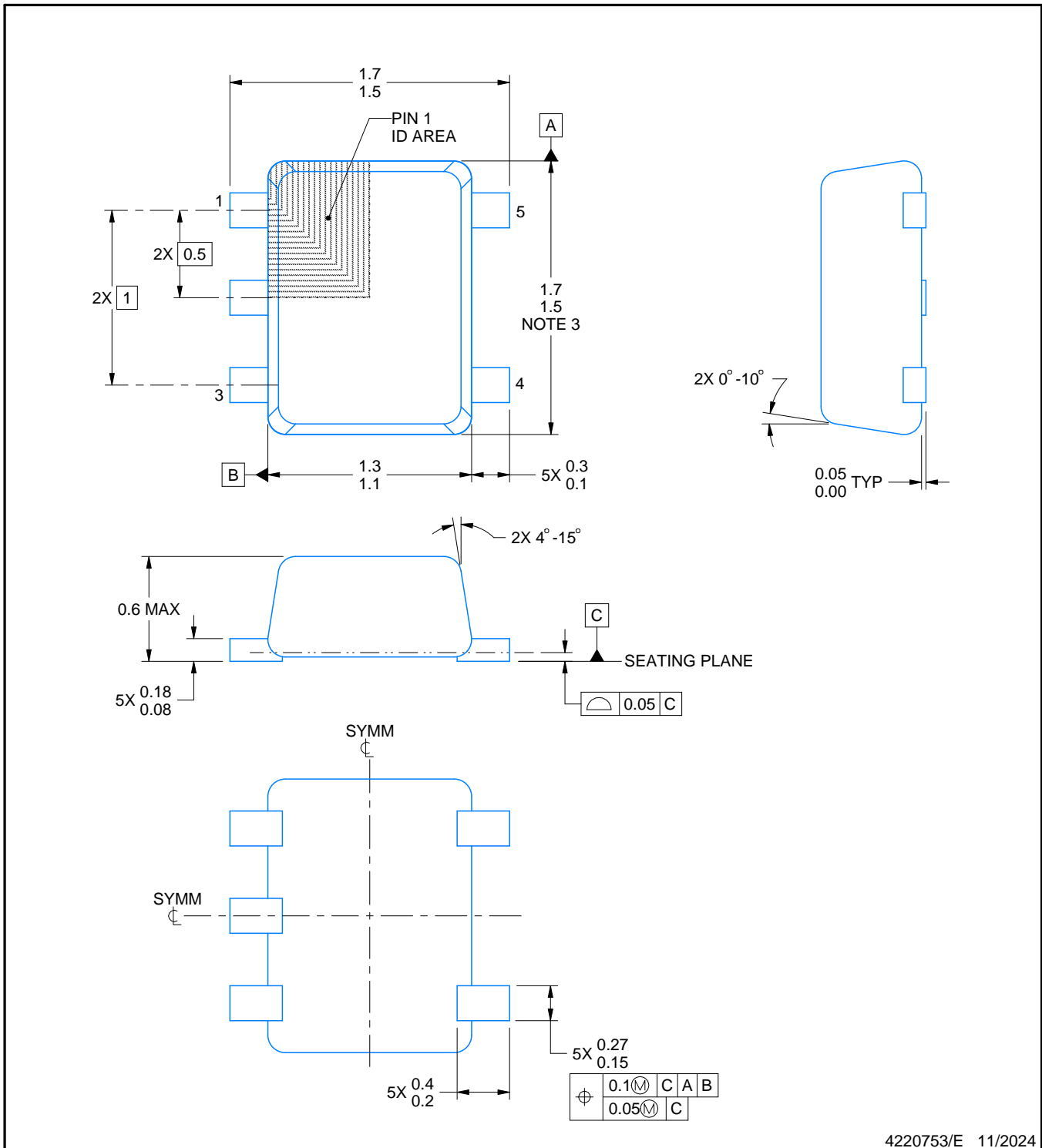

4220753/E 11/2024

NOTES:

1. All linear dimensions are in millimeters. Any dimensions in parenthesis are for reference only. Dimensioning and tolerancing per ASME Y14.5M.
2. This drawing is subject to change without notice.
3. This dimension does not include mold flash, protrusions, or gate burrs. Mold flash, protrusions, or gate burrs shall not exceed 0.15 mm per side.
4. Reference JEDEC registration MO-293 Variation UAAD-1

EXAMPLE BOARD LAYOUT

DRL0005A

SOT - 0.6 mm max height

PLASTIC SMALL OUTLINE



LAND PATTERN EXAMPLE
SCALE:30X

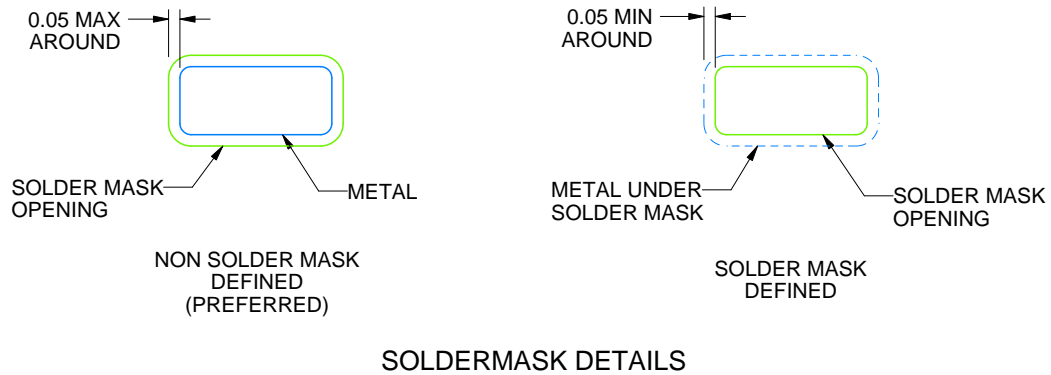

SOLDERMASK DETAILS

4220753/E 11/2024

NOTES: (continued)

- 5. Publication IPC-7351 may have alternate designs.
- 6. Solder mask tolerances between and around signal pads can vary based on board fabrication site.

EXAMPLE STENCIL DESIGN

DRL0005A

SOT - 0.6 mm max height

PLASTIC SMALL OUTLINE

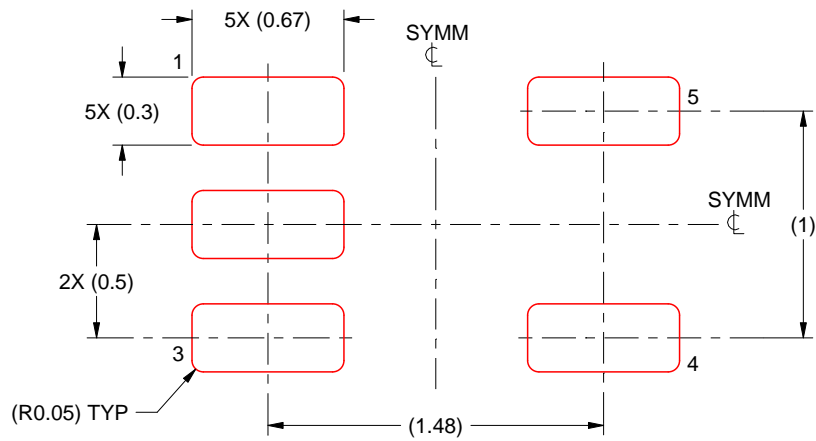

SOLDER PASTE EXAMPLE
BASED ON 0.1 mm THICK STENCIL
SCALE:30X

4220753/E 11/2024

NOTES: (continued)

7. Laser cutting apertures with trapezoidal walls and rounded corners may offer better paste release. IPC-7525 may have alternate design recommendations.
8. Board assembly site may have different recommendations for stencil design.

YZP0005

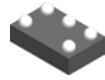

PACKAGE OUTLINE

DSBGA - 0.5 mm max height

DIE SIZE BALL GRID ARRAY

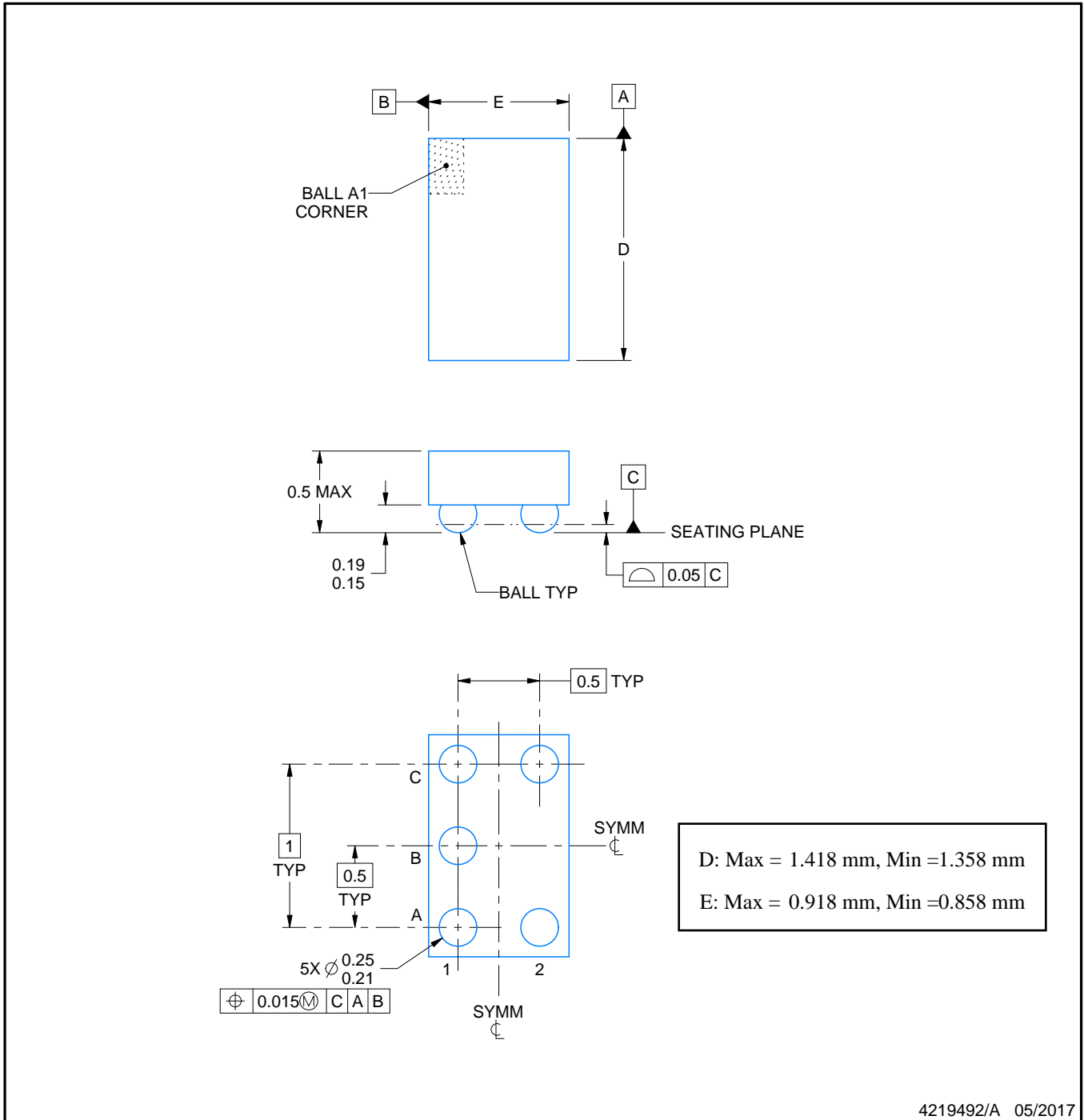

NOTES:

1. All linear dimensions are in millimeters. Any dimensions in parenthesis are for reference only. Dimensioning and tolerancing per ASME Y14.5M.
2. This drawing is subject to change without notice.

EXAMPLE BOARD LAYOUT

YZP0005

DSBGA - 0.5 mm max height

DIE SIZE BALL GRID ARRAY

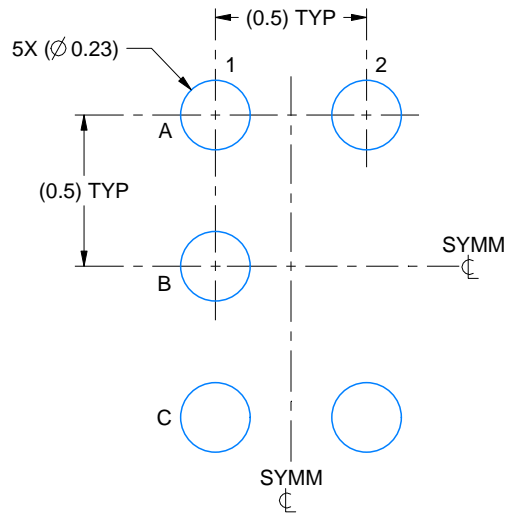

LAND PATTERN EXAMPLE
SCALE:40X

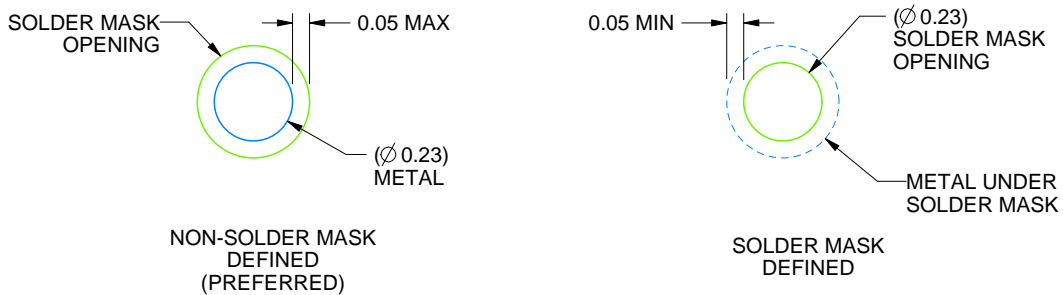

SOLDER MASK DETAILS
NOT TO SCALE

4219492/A 05/2017

NOTES: (continued)

3. Final dimensions may vary due to manufacturing tolerance considerations and also routing constraints. For more information, see Texas Instruments literature number SNVA009 (www.ti.com/lit/snva009).

EXAMPLE STENCIL DESIGN

YZP0005

DSBGA - 0.5 mm max height

DIE SIZE BALL GRID ARRAY

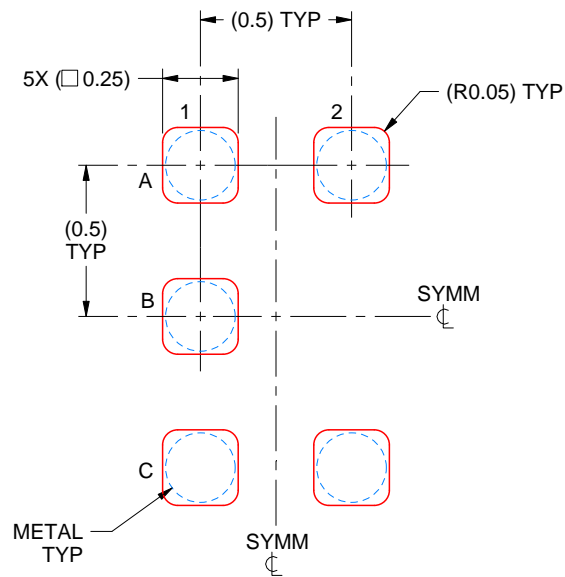

SOLDER PASTE EXAMPLE
BASED ON 0.1 mm THICK STENCIL
SCALE:40X

4219492/A 05/2017

NOTES: (continued)

4. Laser cutting apertures with trapezoidal walls and rounded corners may offer better paste release.

DCK0005A



PACKAGE OUTLINE

SOT - 1.1 max height

SMALL OUTLINE TRANSISTOR

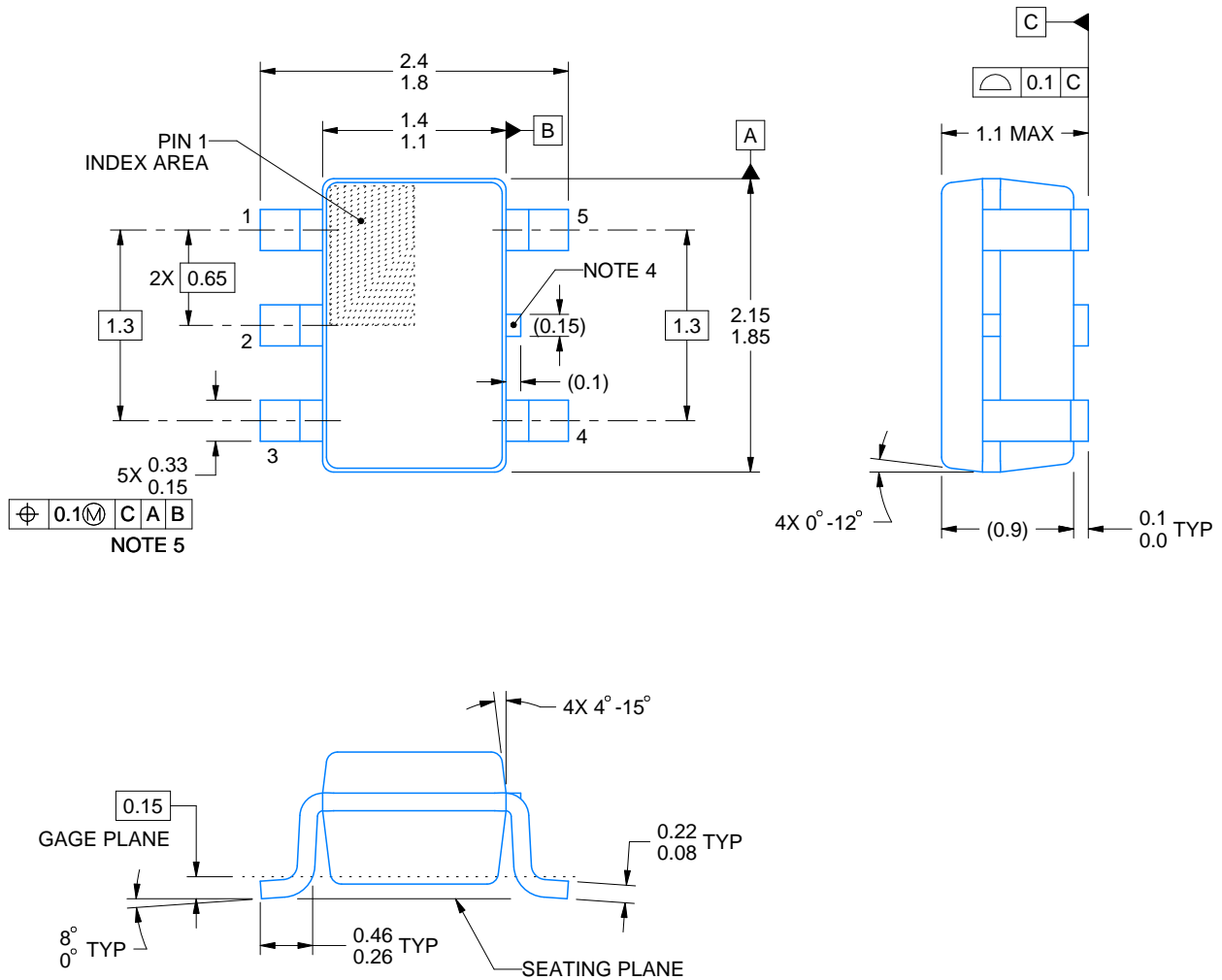

4214834/G 11/2024

NOTES:

1. All linear dimensions are in millimeters. Any dimensions in parenthesis are for reference only. Dimensioning and tolerancing per ASME Y14.5M.
2. This drawing is subject to change without notice.
3. Reference JEDEC MO-203.
4. Support pin may differ or may not be present.
5. Lead width does not comply with JEDEC.
6. Body dimensions do not include mold flash, protrusions, or gate burrs. Mold flash, protrusions, or gate burrs shall not exceed 0.25mm per side

EXAMPLE BOARD LAYOUT

DCK0005A

SOT - 1.1 max height

SMALL OUTLINE TRANSISTOR



LAND PATTERN EXAMPLE
EXPOSED METAL SHOWN
SCALE:18X



SOLDER MASK DETAILS

4214834/G 11/2024

NOTES: (continued)

- 7. Publication IPC-7351 may have alternate designs.
- 8. Solder mask tolerances between and around signal pads can vary based on board fabrication site.

EXAMPLE STENCIL DESIGN

DCK0005A

SOT - 1.1 max height

SMALL OUTLINE TRANSISTOR



SOLDER PASTE EXAMPLE
BASED ON 0.125 THICK STENCIL
SCALE:18X

4214834/G 11/2024

NOTES: (continued)

9. Laser cutting apertures with trapezoidal walls and rounded corners may offer better paste release. IPC-7525 may have alternate design recommendations.
10. Board assembly site may have different recommendations for stencil design.

IMPORTANT NOTICE AND DISCLAIMER

TI PROVIDES TECHNICAL AND RELIABILITY DATA (INCLUDING DATASHEETS), DESIGN RESOURCES (INCLUDING REFERENCE DESIGNS), APPLICATION OR OTHER DESIGN ADVICE, WEB TOOLS, SAFETY INFORMATION, AND OTHER RESOURCES "AS IS" AND WITH ALL FAULTS, AND DISCLAIMS ALL WARRANTIES, EXPRESS AND IMPLIED, INCLUDING WITHOUT LIMITATION ANY IMPLIED WARRANTIES OF MERCHANTABILITY, FITNESS FOR A PARTICULAR PURPOSE OR NON-INFRINGEMENT OF THIRD PARTY INTELLECTUAL PROPERTY RIGHTS.

These resources are intended for skilled developers designing with TI products. You are solely responsible for (1) selecting the appropriate TI products for your application, (2) designing, validating and testing your application, and (3) ensuring your application meets applicable standards, and any other safety, security, regulatory or other requirements.

These resources are subject to change without notice. TI grants you permission to use these resources only for development of an application that uses the TI products described in the resource. Other reproduction and display of these resources is prohibited. No license is granted to any other TI intellectual property right or to any third party intellectual property right. TI disclaims responsibility for, and you fully indemnify TI and its representatives against any claims, damages, costs, losses, and liabilities arising out of your use of these resources.

TI's products are provided subject to [TI's Terms of Sale](#), [TI's General Quality Guidelines](#), or other applicable terms available either on ti.com or provided in conjunction with such TI products. TI's provision of these resources does not expand or otherwise alter TI's applicable warranties or warranty disclaimers for TI products. Unless TI explicitly designates a product as custom or customer-specified, TI products are standard, catalog, general purpose devices.

TI objects to and rejects any additional or different terms you may propose.

Copyright © 2026, Texas Instruments Incorporated

Last updated 10/2025