

OPA1637 High-Fidelity, Low-Noise, Fully-Differential, Burr-Brown™ Audio Operational Amplifier



1 Features

- Low input voltage noise: 3.7 nV/ $\sqrt{\text{Hz}}$ at 1 kHz
- Low THD + N: -120 dB at 1 kHz
- Low supply current: 950 μA at ± 18 V
- Input offset voltage: ± 200 μV (maximum)
- Input bias current: 2 nA (maximum)
- Low bias current noise: 400 fA/ $\sqrt{\text{Hz}}$ at 10 Hz
- Gain-bandwidth product: 9.2 MHz
- Differential output slew rate: 15 V/ μs
- Wide input and output common-mode range
- Wide single-supply operating range: 3 V to 36 V
- Low supply current power-down feature: < 20 μA
- Overload power limit
- Current limit
- Package: 8-pin VSSOP
- Temperature range: -40°C to $+125^\circ\text{C}$

2 Applications

- Professional audio mixer or control surface
- Professional microphones and wireless systems
- Professional speaker systems
- Professional audio amplifier
- Soundbar
- Turntable
- Professional video camera
- Guitar and other instrument amplifier
- Data acquisition (DAQ)

3 Description

The OPA1637 is a low-noise, low total harmonic distortion (THD), fully differential, Burr-Brown™ Audio operational amplifier that easily filters and drives fully differential, audio signal chains.

The OPA1637 also converts single-ended sources to differential outputs required by high-fidelity analog-to-digital converters (ADCs). Designed for exceptional low noise and THD, the bipolar super-beta inputs yield a very low noise figure at very-low quiescent current and input bias current. This device is designed for audio circuits where low power consumption is required along with excellent signal-to-noise ratio (SNR) and spurious-free dynamic range (SFDR).

The OPA1637 features high-voltage supply capability, allowing for supply voltages up to ± 18 V. This capability allows high-voltage differential signal chains to benefit from the improved headroom and dynamic range without adding separate amplifiers for each polarity of the differential signal. Very-low voltage and current noise enables the OPA1637 for use in high-gain configurations with minimal impact to the audio signal noise.

The OPA1637 is characterized for operation over the wide temperature range of -40°C to $+125^\circ\text{C}$, and is available in an 8-pin VSSOP package.

Device Information (1)

| PART NUMBER | PACKAGE | BODY SIZE (NOM) |
|-------------|-----------|--------------------------|
| OPA1637 | VSSOP (8) | 3.00 mm \times 3.00 mm |

- (1) For all available packages, see the package option addendum at the end of the datasheet.

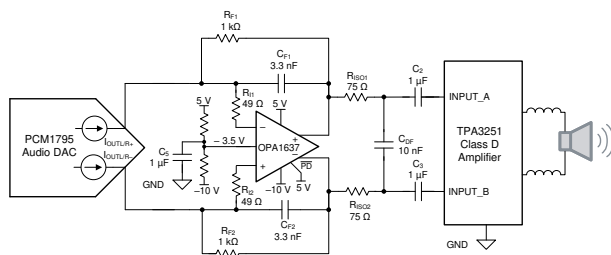

Low-Noise, Low-Power, Fully-Differential Amplifier Gain Block and Interface

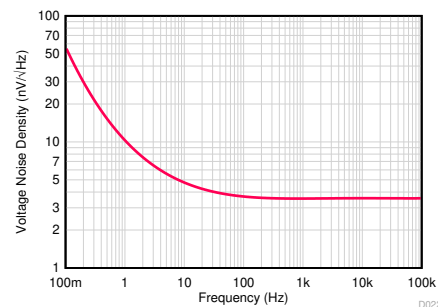

Low Input Voltage Noise



Table of Contents

| | | | |
|--|----|--|----|
| 1 Features | 1 | 8.4 Device Functional Modes..... | 17 |
| 2 Applications | 1 | 9 Application and Implementation | 18 |
| 3 Description | 1 | 9.1 Application Information..... | 18 |
| 4 Revision History | 2 | 9.2 Typical Applications..... | 22 |
| 5 Pin Configuration and Functions | 3 | 10 Power Supply Recommendations | 27 |
| 6 Specifications | 4 | 11 Layout | 27 |
| 6.1 Absolute Maximum Ratings..... | 4 | 11.1 Layout Guidelines..... | 27 |
| 6.2 ESD Ratings..... | 4 | 11.2 Layout Example..... | 27 |
| 6.3 Recommended Operating Conditions..... | 4 | 12 Device and Documentation Support | 28 |
| 6.4 Thermal Information..... | 4 | 12.1 Device Support..... | 28 |
| 6.5 Electrical Characteristics..... | 5 | 12.2 Documentation Support..... | 28 |
| 6.6 Typical Characteristics..... | 8 | 12.3 Receiving Notification of Documentation Updates.. | 28 |
| 7 Parameter Measurement Information | 15 | 12.4 Support Resources..... | 28 |
| 7.1 Characterization Configuration..... | 15 | 12.5 Trademarks..... | 28 |
| 8 Detailed Description | 16 | 12.6 Electrostatic Discharge Caution..... | 28 |
| 8.1 Overview..... | 16 | 12.7 Glossary..... | 28 |
| 8.2 Functional Block Diagram..... | 16 | 13 Mechanical, Packaging, and Orderable Information | 28 |
| 8.3 Feature Description..... | 17 | | |

4 Revision History

NOTE: Page numbers for previous revisions may differ from page numbers in the current version.

| Changes from Revision A (May 2020) to Revision B (August 2020) | Page |
|---|-------------|
| • Updated the numbering format for tables, figures, and cross-references throughout the document..... | 1 |
| • Changed front page application diagram to show correct label and value for R_{F1} | 1 |
| • Changed Figure 7-1 to show correct labels..... | 15 |
| • Changed Figure 9-5 to show correct label and value for R_{F1} | 22 |
| • Changed Figure 9-8 negative rail from 0 V to –5 V..... | 24 |

| Changes from Revision * (December 2019) to Revision A (May 2020) | Page |
|---|-------------|
| • Changed device status from advanced information (preview) to production data (active) | 1 |

5 Pin Configuration and Functions

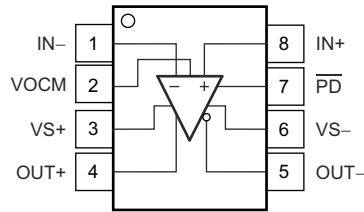

Figure 5-1. DGK Package, 8-Pin VSSOP, Top View

Pin Functions

| PIN | | I/O | DESCRIPTION |
|------|-----|-----|--|
| NAME | NO. | | |
| IN- | 1 | I | Inverting (negative) amplifier input |
| IN+ | 8 | I | Noninverting (positive) amplifier input |
| OUT- | 5 | O | Inverting (negative) amplifier output |
| OUT+ | 4 | O | Noninverting (positive) amplifier output |
| PD | 7 | I | Power down. $\overline{\text{PD}}$ = logic low = power off mode. $\overline{\text{PD}}$ = logic high = normal operation. The logic threshold is referenced to VS+. If power down is not needed, leave $\overline{\text{PD}}$ floating. |
| VOCM | 2 | I | Output common-mode voltage control input |
| VS- | 6 | I | Negative power-supply input |
| VS+ | 3 | I | Positive power-supply input |

6 Specifications

6.1 Absolute Maximum Ratings

over operating free-air temperature range (unless otherwise noted)⁽¹⁾

| | | | MIN | MAX | UNIT |
|------------------|---|---------------|------------------------|------------------------|------|
| V _S | Supply voltage | Single supply | | 40 | V |
| | | Dual supply | | ±20 | V |
| | IN+, IN-, Differential voltage ⁽²⁾ | | | ±0.5 | V |
| | IN+, IN-, VO _{CM} , P _D , OUT+, OUT- voltage ⁽³⁾ | | V _{VS-} - 0.5 | V _{VS+} + 0.5 | V |
| | IN+, IN- current | | -10 | 10 | mA |
| | OUT+, OUT- current | | -50 | 50 | mA |
| | Output short-circuit ⁽⁴⁾ | | | Continuous | |
| T _A | Operating Temperature | | -40 | 150 | °C |
| T _J | Junction Temperature | | -40 | 175 | °C |
| T _{stg} | Storage Temperature | | -65 | 150 | °C |

- (1) Stresses beyond those listed under *Absolute Maximum Ratings* may cause permanent damage to the device. These are stress ratings only, which do not imply functional operation of the device at these or any other conditions beyond those indicated under *Recommended Operating Conditions*. Exposure to absolute-maximum-rated conditions for extended periods may affect device reliability.
- (2) Input pins IN+ and IN- are connected with anti-parallel diodes in between the two terminals. Differential input signals that are greater than 0.5 V or less than -0.5 V must be current-limited to 10 mA or less.
- (3) Input terminals are diode-clamped to the supply rails (V_{S+}, V_{S-}). Input signals that swing more than 0.5 V greater or less the supply rails must be current-limited to 10 mA or less.
- (4) Short-circuit to V_S / 2.

6.2 ESD Ratings

| | | | VALUE | UNIT |
|--------------------|-------------------------|--|-------|------|
| V _(ESD) | Electrostatic discharge | Human body model (HBM), per ANSI/ESDA/JEDEC JS-001 ⁽¹⁾ | ±1000 | V |
| | | Charged device model (CDM), per JEDEC specification JESD22-C101 ⁽²⁾ | ±500 | |

- (1) JEDEC document JEP155 states that 500-V HBM allows safe manufacturing with a standard ESD control process.
- (2) JEDEC document JEP157 states that 250-V CDM allows safe manufacturing with a standard ESD control process.

6.3 Recommended Operating Conditions

over operating free-air temperature range (unless otherwise noted)

| | | | MIN | NOM | MAX | UNIT |
|----------------|-----------------------|---------------|------|-----|-----|------|
| V _S | Supply voltage | Single-supply | 3 | | 36 | V |
| | | Dual-supply | ±1.5 | | ±18 | |
| T _A | Specified temperature | | -40 | | 125 | °C |

6.4 Thermal Information

| THERMAL METRIC ⁽¹⁾ | | OPA1637 | UNIT |
|-------------------------------|--|-------------|------|
| | | DGK (VSSOP) | |
| | | 8 PINS | |
| R _{θJA} | Junction-to-ambient thermal resistance | 181.1 | °C/W |
| R _{θJC(top)} | Junction-to-case (top) thermal resistance | 68.3 | °C/W |
| R _{θJB} | Junction-to-board thermal resistance | 102.8 | °C/W |
| ψ _{JT} | Junction-to-top characterization parameter | 10.6 | °C/W |
| ψ _{JB} | Junction-to-board characterization parameter | 101.1 | °C/W |
| R _{θJC(bot)} | Junction-to-case (bottom) thermal resistance | N/A | °C/W |

- (1) For information about traditional and new thermal metrics, see the [Semiconductor and IC Package Thermal Metrics](#) application report.

6.5 Electrical Characteristics

at $T_A = 25^\circ\text{C}$, V_S (dual supply) = $\pm 1.5\text{ V}$ to $\pm 18\text{ V}$, $V_{VOCM} = 0\text{ V}$, input common mode voltage (V_{ICM}) = 0 V , $R_F = 2\text{ k}\Omega$, $V_{PD} = V_{VS+}$, $R_L = 10\text{ k}\Omega$ ⁽¹⁾ (unless otherwise noted)

| PARAMETER | | TEST CONDITIONS | MIN | TYP | MAX | UNIT |
|--|-------------------------------------|--|-----|---------|-----------|------------------------------|
| FREQUENCY RESPONSE | | | | | | |
| SSBW | Small-signal bandwidth | V_O ⁽²⁾ = 100 mV_{PP} , $G = -1\text{ V/V}$ | | 7 | | MHz |
| GBP | Gain-bandwidth product | $V_O = 100\text{ mV}_{PP}$, $G = -10\text{ V/V}$ | | 9.2 | | MHz |
| FBP | Full-power bandwidth | $V_O = -1\text{ V}_{PP}$, $G = -1\text{ V/V}$ | | 2.5 | | MHz |
| SR | Slew rate | $G = -1$, 10-V step | | 15 | | V/ μs |
| | Settling time | 0.1% of final value, $G = -1\text{ V/V}$, $V_O = 10\text{-V}$ step | | 1 | | μs |
| | | 0.01% of final value, $G = -1\text{ V/V}$, $V_O = 10\text{-V}$ step | | 2 | | |
| THD+N | Total harmonic distortion and noise | Differential input, $f = 1\text{ kHz}$, $V_O = 10\text{ V}_{PP}$ | | -120 | | dB |
| | | | | 0.0001 | | % |
| | | Single-ended input, $f = 1\text{ kHz}$, $V_O = 10\text{ V}_{PP}$ | | -115 | | dB |
| | | | | 0.00018 | | % |
| | | Differential input, $f = 10\text{ kHz}$, $V_O = 10\text{ V}_{PP}$ | | -112 | | dB |
| | | | | 0.00025 | | % |
| Single-ended input, $f = 10\text{ kHz}$, $V_O = 10\text{ V}_{PP}$ | | -107 | | dB | | |
| | | 0.00045 | | % | | |
| HD2 | Second-order harmonic distortion | Differential input, $f = 1\text{ kHz}$, $V_O = 10\text{ V}_{PP}$ | | -126 | | dB |
| | | Single-ended input, $f = 1\text{ kHz}$, $V_O = 10\text{ V}_{PP}$ | | -120 | | |
| HD3 | Third-order harmonic distortion | Differential input, $f = 1\text{ kHz}$, $V_O = 10\text{ V}_{PP}$ | | -131 | | dB |
| | | Single-ended input, $f = 1\text{ kHz}$, $V_O = 10\text{ V}_{PP}$ | | -119 | | |
| | Overdrive recovery time | $G = 5\text{ V/V}$, $2\times$ output overdrive, dc-coupled | | 3.3 | | μs |
| NOISE | | | | | | |
| e_n | Input differential voltage noise | $f = 1\text{ kHz}$ | | 3.7 | | nV/ $\sqrt{\text{Hz}}$ |
| | | $f = 10\text{ Hz}$ | | 4 | | |
| | | $f = 0.1\text{ Hz}$ to 10 Hz | | 0.1 | | |
| e_i | Input current noise, each input | $f = 1\text{ kHz}$ | | 300 | | fA/ $\sqrt{\text{Hz}}$ |
| | | $f = 10\text{ Hz}$ | | 400 | | |
| | | $f = 0.1\text{ Hz}$ to 10 Hz | | 13.4 | | |
| OFFSET VOLTAGE | | | | | | |
| V_{IO} | Input-referred offset voltage | | | 20 | ± 200 | μV |
| | | $T_A = -40^\circ\text{C}$ to $+125^\circ\text{C}$ | | | ± 250 | |
| | Input offset voltage drift | $T_A = -40^\circ\text{C}$ to $+125^\circ\text{C}$ | | 0.1 | ± 1 | $\mu\text{V}/^\circ\text{C}$ |
| PSRR | Power-supply rejection ratio | | | 0.025 | ± 0.5 | $\mu\text{V/V}$ |
| | | $T_A = -40^\circ\text{C}$ to $+125^\circ\text{C}$ | | | ± 1 | |
| INPUT BIAS CURRENT | | | | | | |
| I_B | Input bias current | | | 0.2 | ± 2 | nA |
| | | $T_A = -40^\circ\text{C}$ to $+125^\circ\text{C}$ | | | ± 4 | |
| | Input bias current drift | $T_A = -40^\circ\text{C}$ to $+125^\circ\text{C}$ | | 2 | ± 15 | pA/ $^\circ\text{C}$ |
| I_{OS} | Input offset current | | | 0.2 | ± 1 | nA |
| | | $T_A = -40^\circ\text{C}$ to $+125^\circ\text{C}$ | | | ± 3 | |
| | Input offset current drift | $T_A = -40^\circ\text{C}$ to $+125^\circ\text{C}$ | | 1 | ± 10 | pA/ $^\circ\text{C}$ |

6.5 Electrical Characteristics (continued)

at $T_A = 25^\circ\text{C}$, V_S (dual supply) = $\pm 1.5\text{ V}$ to $\pm 18\text{ V}$, $V_{VOCM} = 0\text{ V}$, input common mode voltage (V_{ICM}) = 0 V , $R_F = 2\text{ k}\Omega$, $V_{PD} = V_{VS+}$, $R_L = 10\text{ k}\Omega$ ⁽¹⁾ (unless otherwise noted)

| PARAMETER | | TEST CONDITIONS | MIN | TYP | MAX | UNIT |
|--|---|--|---------------|-----------|---------------|------------------------------|
| INPUT VOLTAGE | | | | | | |
| | Common-mode voltage | $T_A = -40^\circ\text{C}$ to $+125^\circ\text{C}$ | $V_{VS-} + 1$ | | $V_{VS+} - 1$ | V |
| CMRR | Common-mode rejection ratio | $V_{VS-} + 1\text{ V} \leq V_{ICM} \leq V_{VS+} - 1\text{ V}$ | | 140 | | dB |
| | | $V_{VS-} + 1\text{ V} \leq V_{ICM} \leq V_{VS+} - 1\text{ V}$, $V_S = \pm 18\text{ V}$ | 126 | 140 | | |
| | | $V_{VS-} + 1\text{ V} \leq V_{ICM} \leq V_{VS+} - 1\text{ V}$, $V_S = \pm 18\text{ V}$ $T_A = -40^\circ\text{C}$ to $+125^\circ\text{C}$ | 120 | | | |
| INPUT IMPEDANCE | | | | | | |
| | Input impedance differential mode | $V_{ICM} = 0\text{ V}$ | | 1 1 | | $\text{G}\Omega$ pF |
| OPEN-LOOP GAIN | | | | | | |
| A_{OL} | Open-loop voltage gain | $V_S = \pm 2.5\text{ V}$, $V_{VS-} + 0.2\text{ V} < V_O < V_{VS+} - 0.2\text{ V}$ | 115 | 120 | | dB |
| | | $V_S = \pm 2.5\text{ V}$, $V_{VS-} + 0.3\text{ V} < V_O < V_{VS+} - 0.3\text{ V}$, $T_A = -40^\circ\text{C}$ to $+125^\circ\text{C}$ | 110 | 120 | | |
| | | $V_S = \pm 15\text{ V}$, $V_{VS-} + 0.6\text{ V} < V_O < V_{VS+} - 0.6\text{ V}$ | 115 | 120 | | |
| | | $V_S = \pm 15\text{ V}$, $V_{VS-} + 0.6\text{ V} < V_O < V_{VS+} - 0.6\text{ V}$, $T_A = -40^\circ\text{C}$ to $+125^\circ\text{C}$ | 110 | 120 | | |
| OUTPUT | | | | | | |
| | Output voltage difference from supply voltage | $V_S = \pm 2.5\text{ V}$ | | ± 100 | | mV |
| | | $V_S = \pm 2.5\text{ V}$, $T_A = -40^\circ\text{C}$ to $+125^\circ\text{C}$ | | ± 100 | | |
| | | $V_S = \pm 18\text{ V}$ | | ± 230 | | |
| | | $V_S = \pm 18\text{ V}$, $T_A = -40^\circ\text{C}$ to $+125^\circ\text{C}$ | | ± 270 | | |
| I_{SC} | Short-circuit current | | | ± 31 | | mA |
| C_{LOAD} | Capacitive load drive | Differential capacitive load, no output Isolation resistors, phase margin = 30° | | 50 | | pF |
| Z_O | Open-loop output impedance | $f = 100\text{ kHz}$ (differential) | | 14 | | Ω |
| OUTPUT COMMON-MODE VOLTAGE (V_{OCM}) CONTROL | | | | | | |
| | Input Voltage Range | $V_S = \pm 2.5\text{ V}$ | $V_{VS-} + 1$ | | $V_{VS+} - 1$ | |
| | | $V_S = \pm 18\text{ V}$ | $V_{VS-} + 2$ | | $V_{VS+} - 2$ | |
| | Small-signal bandwidth from V _{OCM} pin | $V_{VOCM} = 100\text{ mV}_{PP}$ | | 2 | | MHz |
| | Large-signal bandwidth from V _{OCM} pin | $V_{VOCM} = 0.6\text{ V}_{PP}$ | | 5.7 | | |
| | Slew rate from V _{OCM} pin | $V_{VOCM} = 0.5\text{-V}$ step, rising | | 3.5 | | V/ μs |
| | | $V_{VOCM} = 0.5\text{-V}$ step, falling | | 5.5 | | |
| | DC output balance | V_{VOCM} fixed midsupply ($V_O = \pm 1\text{ V}$) | | 78 | | dB |
| | V _{OCM} input impedance | | | 2.5 1 | | $\text{M}\Omega$ pF |
| | V _{OCM} offset from mid-supply | V _{OCM} pin floating | | 2 | | mV |
| | V _{OCM} common-mode offset voltage | $V_{VOCM} = V_{ICM}$, $V_O = 0\text{ V}$ | | ± 1 | ± 6 | mV |
| | | $V_{VOCM} = V_{ICM}$, $V_O = 0\text{ V}$, $T_A = -40^\circ\text{C}$ to $+125^\circ\text{C}$ | | | ± 10 | |
| | V _{OCM} common-mode offset voltage drift | $V_{VOCM} = V_{ICM}$, $V_O = 0\text{ V}$, $T_A = -40^\circ\text{C}$ to $+125^\circ\text{C}$ | | ± 20 | ± 60 | $\mu\text{V}/^\circ\text{C}$ |
| POWER SUPPLY | | | | | | |
| I_Q | Quiescent operating current | | | 0.95 | 1.2 | mA |
| | | $T_A = -40^\circ\text{C}$ to $+125^\circ\text{C}$ | | | | |

6.5 Electrical Characteristics (continued)

at $T_A = 25^\circ\text{C}$, V_S (dual supply) = $\pm 1.5\text{ V}$ to $\pm 18\text{ V}$, $V_{VOCM} = 0\text{ V}$, input common mode voltage (V_{ICM}) = 0 V , $R_F = 2\text{ k}\Omega$, $V_{\overline{PD}} = V_{VS+}$, $R_L = 10\text{ k}\Omega$ ⁽¹⁾ (unless otherwise noted)

| PARAMETER | | TEST CONDITIONS | MIN | TYP | MAX | UNIT |
|--------------------------|------------------------------|---|-----------------|-----------------|-----|---------------|
| POWER DOWN | | | | | | |
| $V_{\overline{PD}(HI)}$ | Power-down enable voltage | $T_A = -40^\circ\text{C}$ to $+125^\circ\text{C}$ | $V_{VS+} - 0.5$ | | | V |
| $V_{\overline{PD}(LOW)}$ | Power-down disable voltage | $T_A = -40^\circ\text{C}$ to $+125^\circ\text{C}$ | | $V_{VS+} - 2.0$ | | V |
| | \overline{PD} bias current | $V_{\overline{PD}} = V_{VS+} - 2\text{ V}$ | | 1 | 2 | μA |
| | Powerdown quiescent current | | | 10 | 20 | μA |
| | Turn-on time delay | $V_{IN} = 100\text{ mV}$, time to $V_O = 90\%$ of final value | | 10 | | μs |
| | Turn-off time delay | $V_{IN} = 100\text{ mV}$, time to $V_O = 10\%$ of original value | | 15 | | μs |

- (1) R_L is connected differentially, from $\text{OUT}+$ to $\text{OUT}-$.
 (2) V_O refers to the differential output voltage, $V_{\text{OUT}+} - V_{\text{OUT}-}$.

6.6 Typical Characteristics

at $V_S = \pm 18\text{ V}$, $T_A = 25^\circ\text{C}$, $V_{VOCM} = V_{VICM} = 0\text{ V}$, $R_F = 2\text{ k}\Omega$, $R_L = 10\text{ k}\Omega$, $V_{OUT} = 2\text{ V}_{PP}$, $G = 1\text{ V/V}$, and $V_{PD} = V_S$ + (unless otherwise noted)

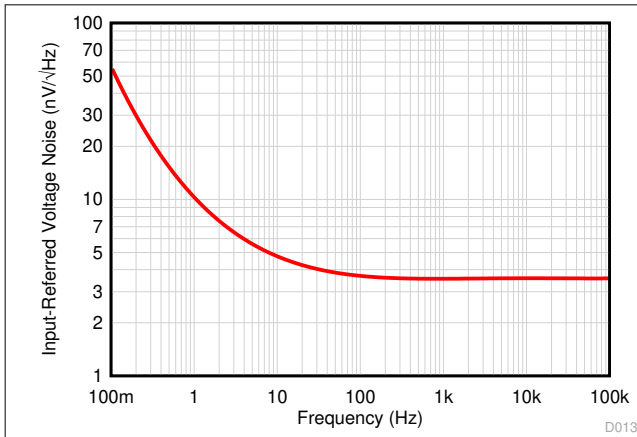

Figure 6-1. Input-Referred Voltage Noise vs Frequency

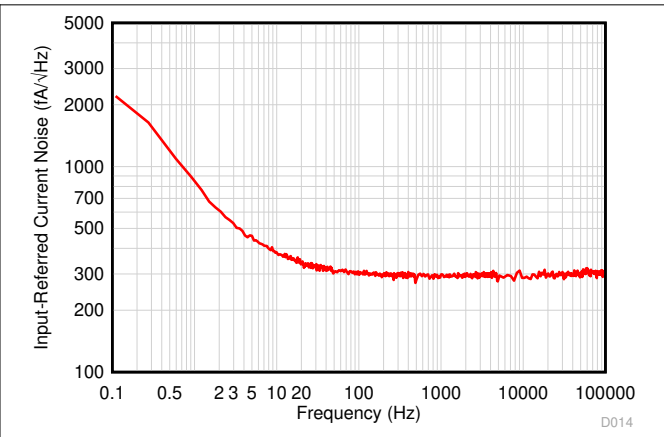

Figure 6-2. Current Noise vs Frequency

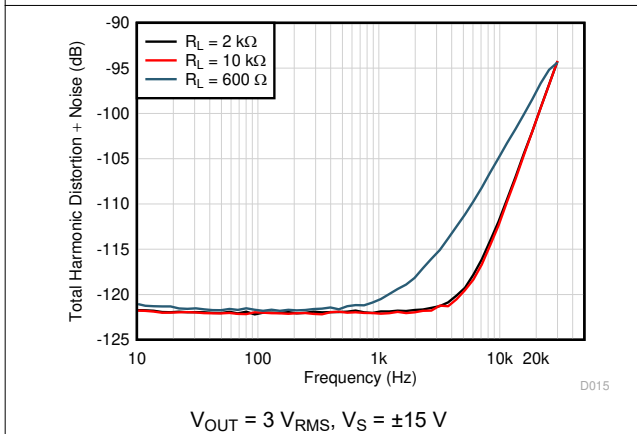

Figure 6-3. Total Harmonic Distortion + Noise vs Frequency

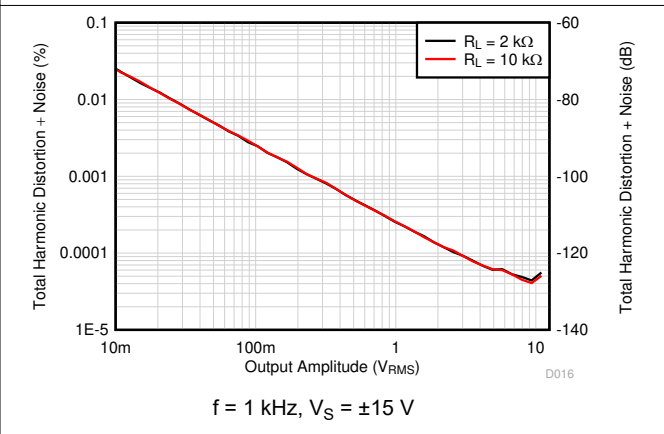

Figure 6-4. Total Harmonic Noise + Distortion vs Amplitude

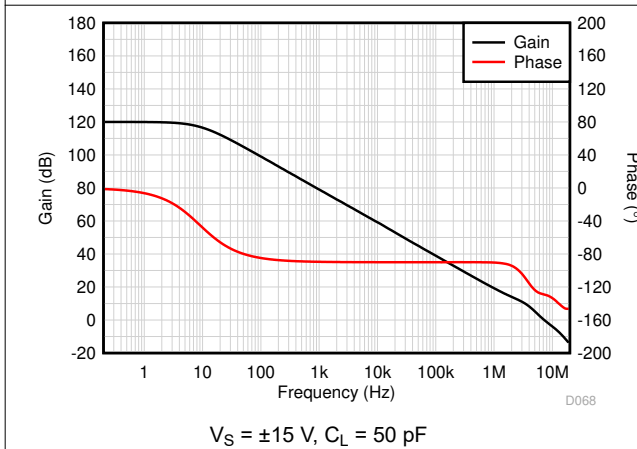

Figure 6-5. Open Loop Gain vs Frequency

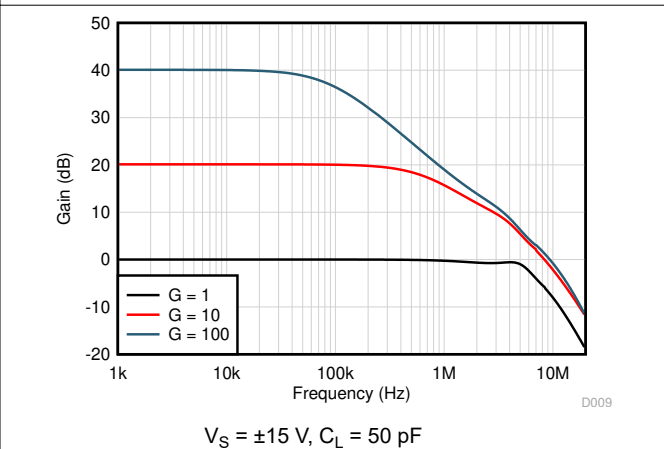

Figure 6-6. Closed-Loop Gain vs Frequency

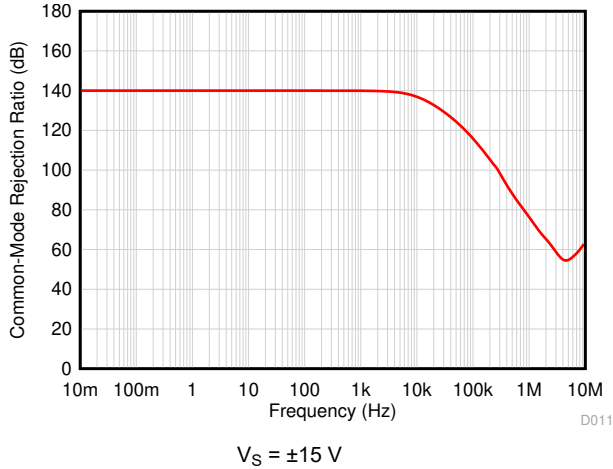

Figure 6-7. Common Mode Rejection Ratio vs Frequency

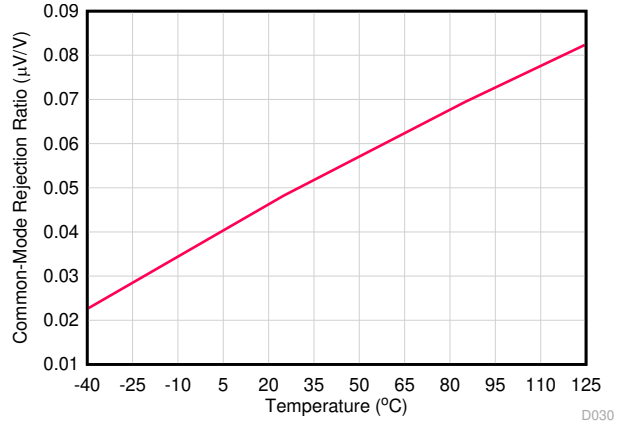

Figure 6-8. Common Mode Rejection Ratio vs Temperature

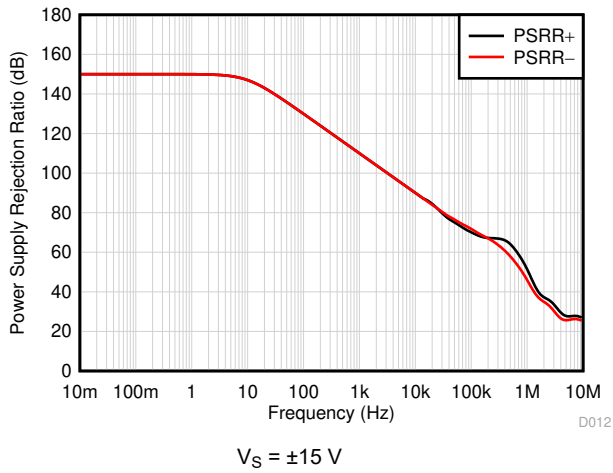

Figure 6-9. Power Supply Rejection Ratio vs Frequency

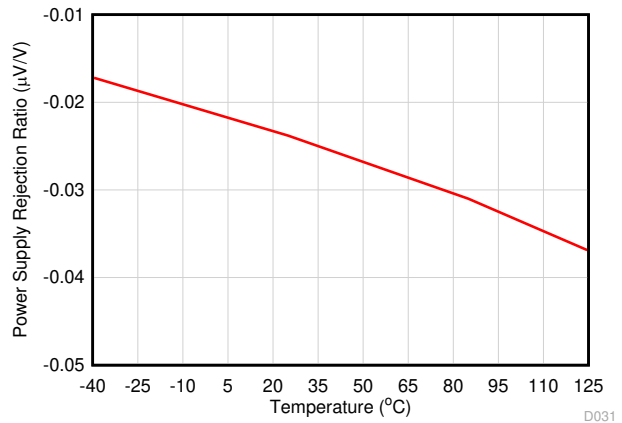

Figure 6-10. Power Supply Rejection Ratio vs Temperature

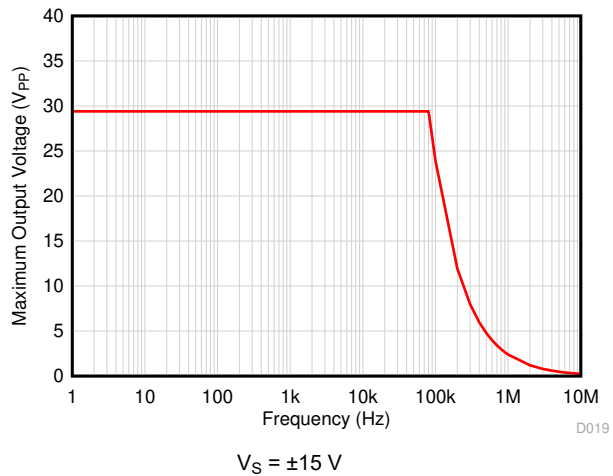

Figure 6-11. Maximum Output Voltage vs Frequency

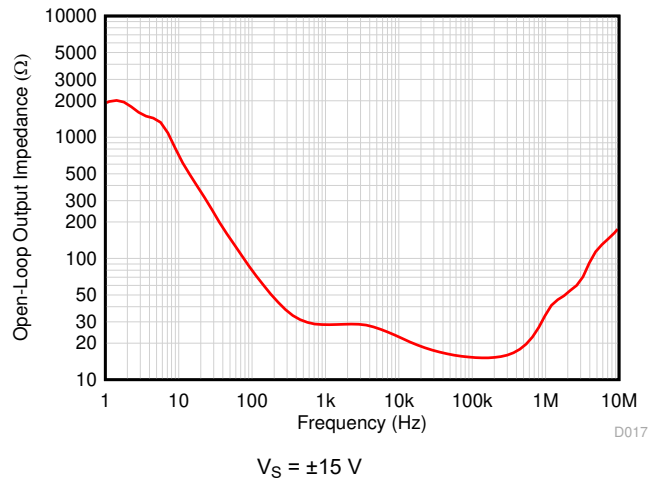

Figure 6-12. Output Impedance vs Frequency

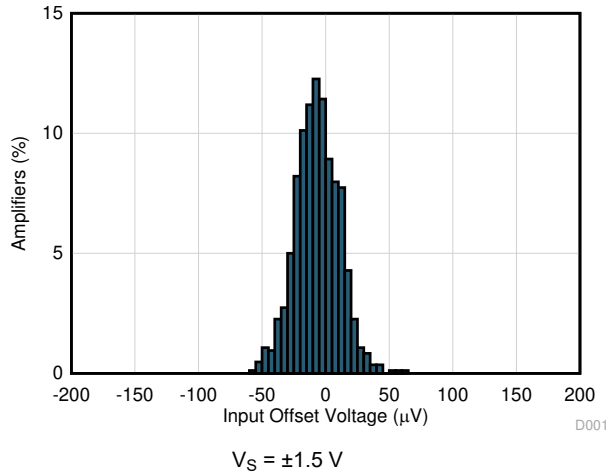

Figure 6-13. Input Offset Voltage Histogram

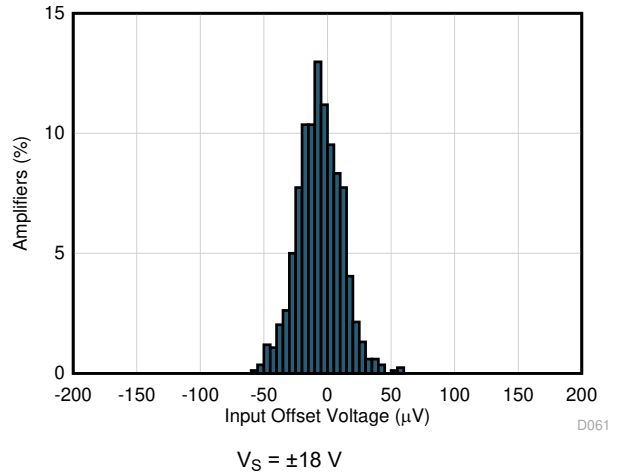

Figure 6-14. Input Offset Voltage Histogram

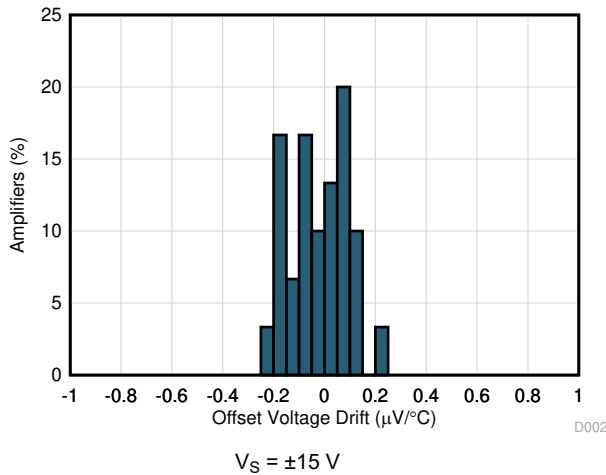

Figure 6-15. Input Offset Voltage Drift Histogram

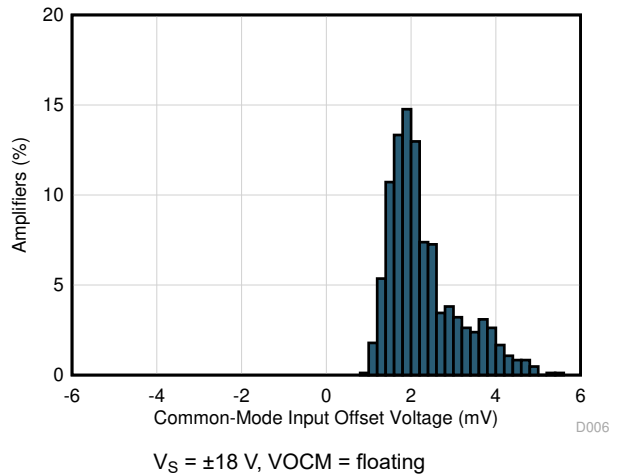

Figure 6-16. Output Common Mode Voltage Offset

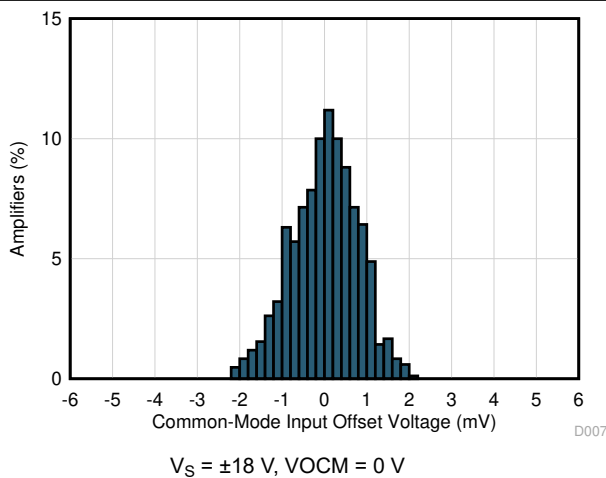

Figure 6-17. Output Common Mode Voltage Offset

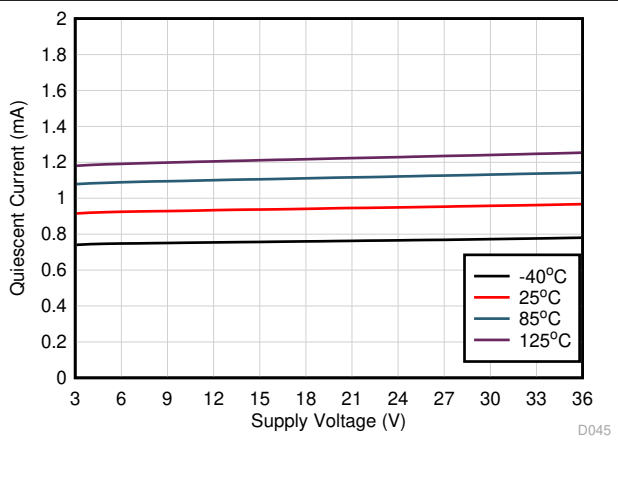

Figure 6-18. Quiescent Current vs Supply Voltage

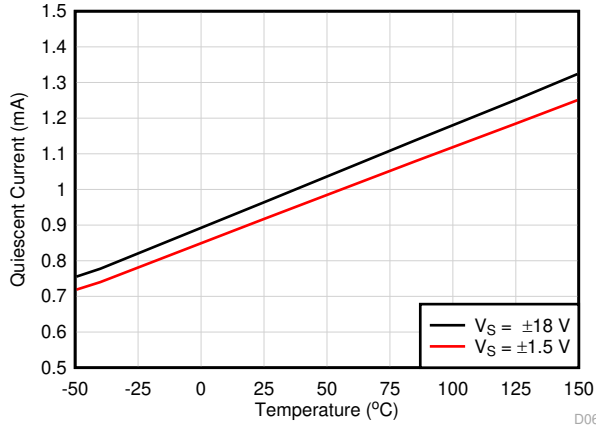

Figure 6-19. Quiescent Current vs Temperature

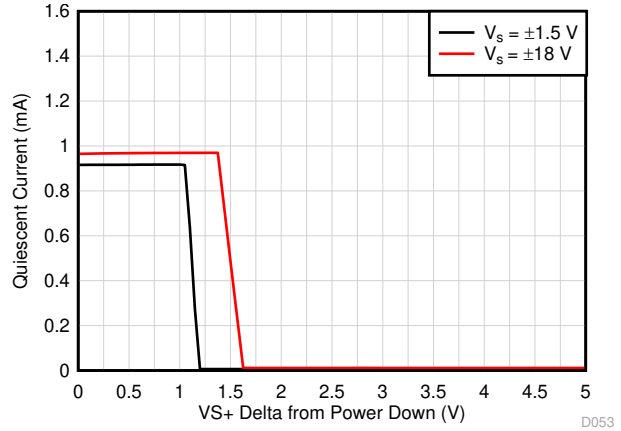

Figure 6-20. Quiescent Current vs Power-Down Delta from Supply Voltage

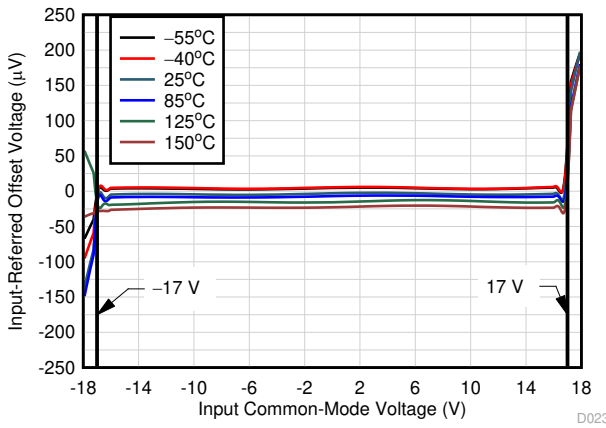

Figure 6-21. Input Offset Voltage vs Input Common-Mode Voltage

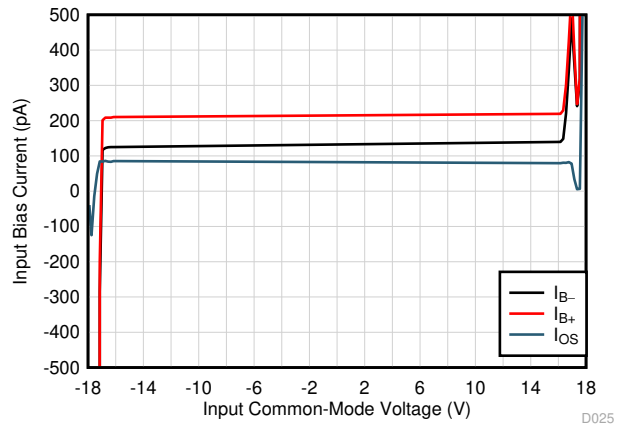

Figure 6-22. Input Bias Current vs Input Common-Mode Voltage

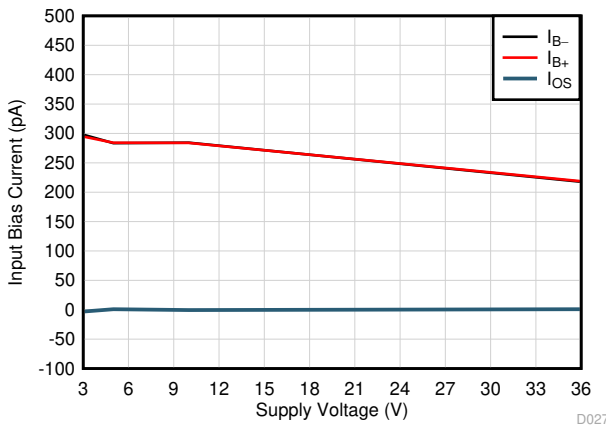

Figure 6-23. Input Bias Current vs Supply Voltage

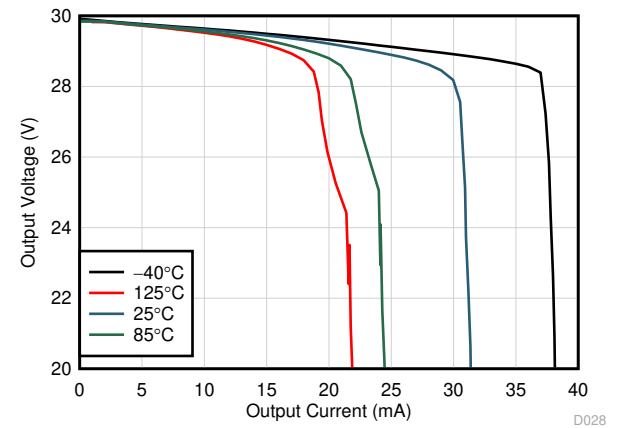

Figure 6-24. Output Voltage vs Output Current

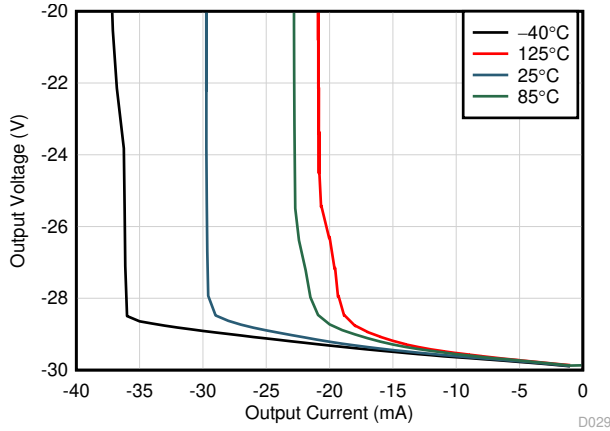

Figure 6-25. Output Voltage vs Output Current

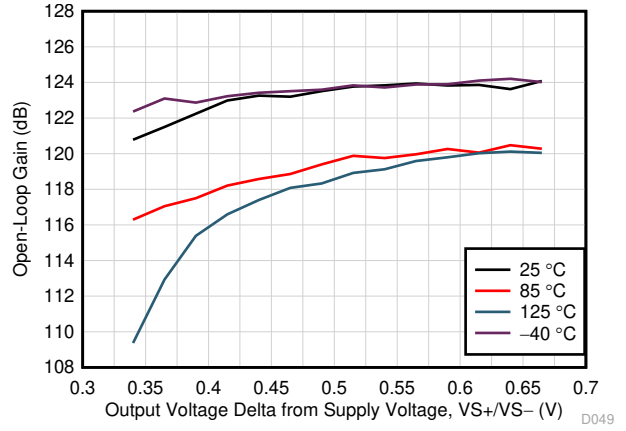

Figure 6-26. Open-Loop Gain vs Output Delta From Supply

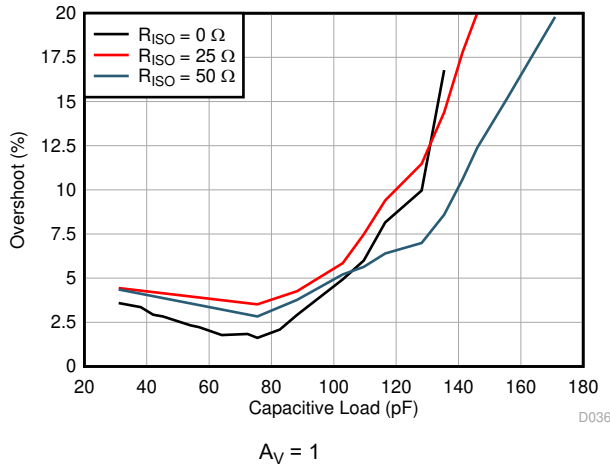

Figure 6-27. Small-Signal Overshoot vs Capacitive Load

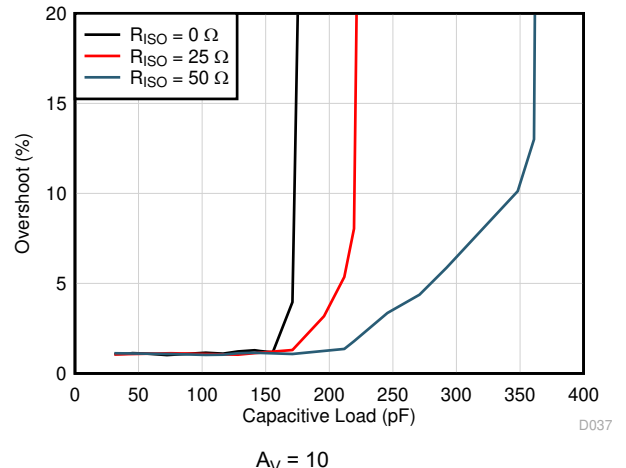

Figure 6-28. Small-Signal Overshoot vs Capacitive Load

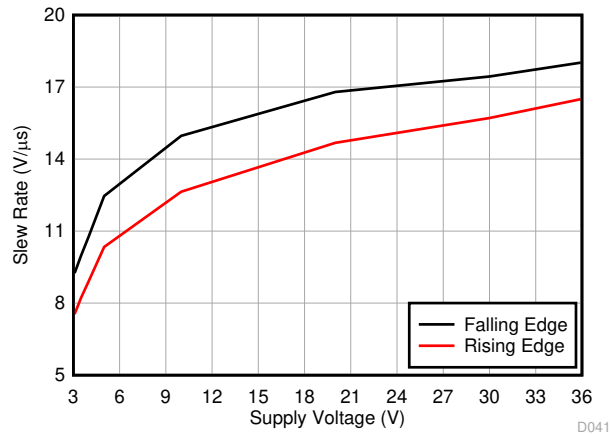

Figure 6-29. Output Slew Rate vs Supply Voltage

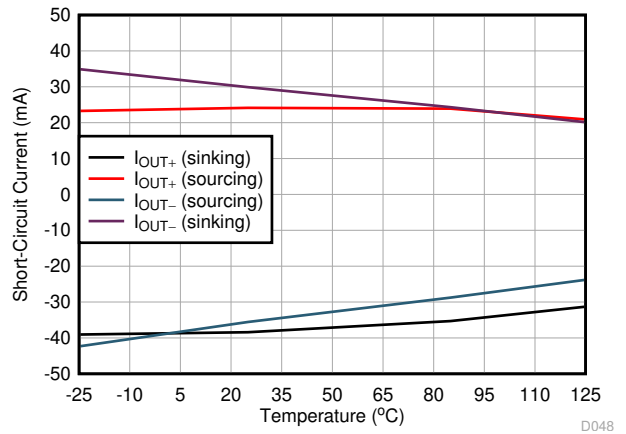

Figure 6-30. Short-Circuit Current vs Temperature

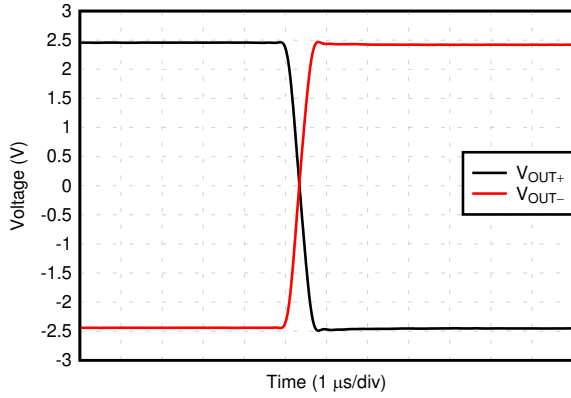

Figure 6-31. Large-Signal Step Response

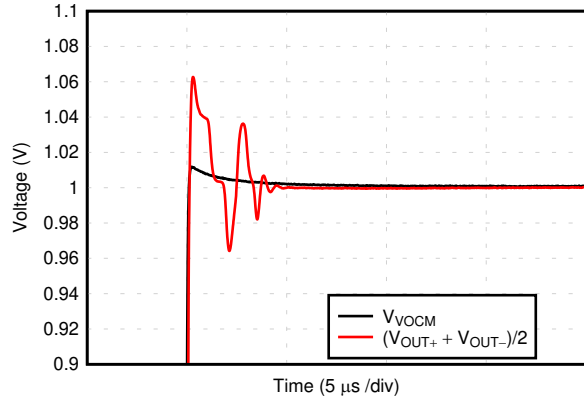

Figure 6-32. Output Common-Mode Step Response, Rising

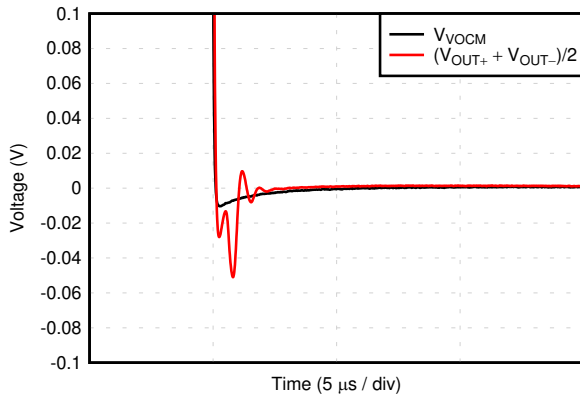

Figure 6-33. Output Common-Mode Step Response, Falling

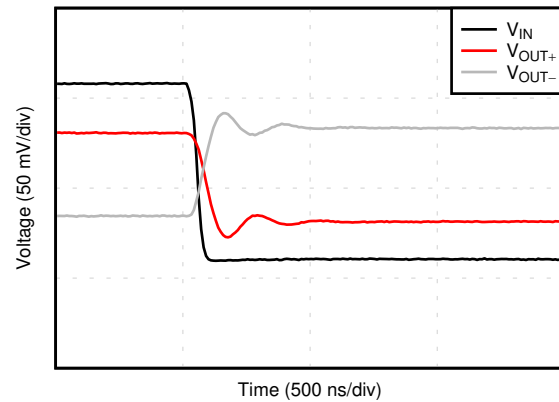

Figure 6-34. Small-Signal Step Response, Falling

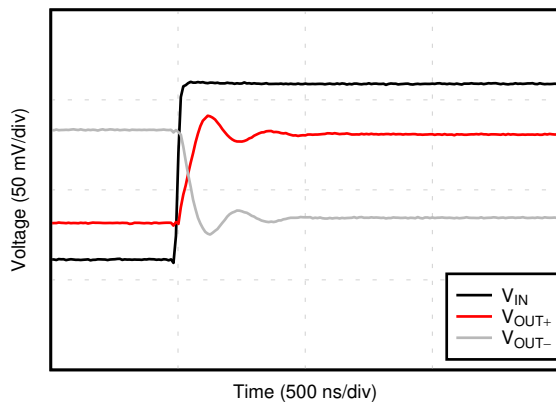

Figure 6-35. Small-Signal Step Response, Rising

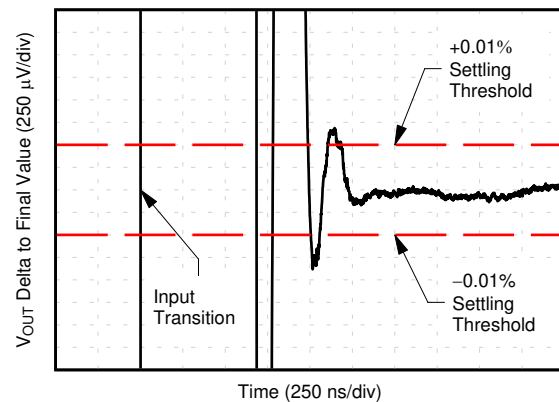

Figure 6-36. Output Settling Time to $\pm 0.01\%$

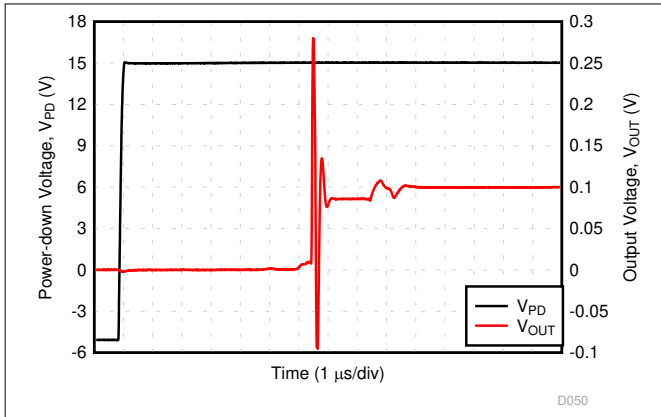

Figure 6-37. Power-Down Time (PD Low to High)

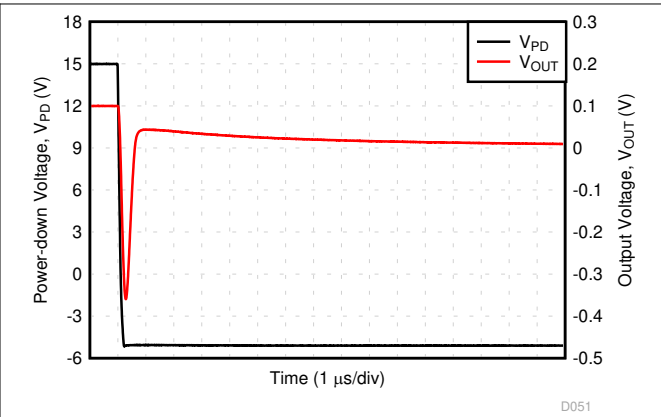

Figure 6-38. Power-Down Time (PD High to Low)

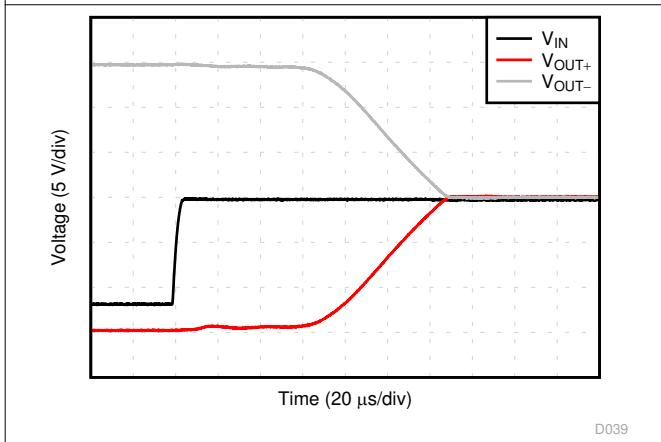

Figure 6-39. Output Negative Overload Recovery

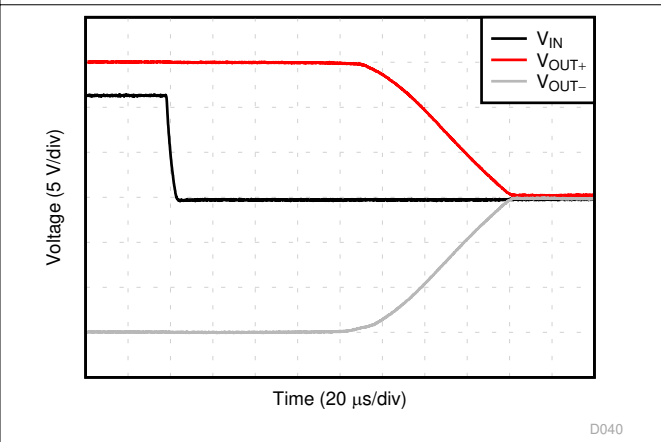

Figure 6-40. Output Positive Overload Recovery

7 Parameter Measurement Information

7.1 Characterization Configuration

The OPA1637 provides the advantages of a fully differential amplifier (FDA) configuration that offers very low noise and harmonic distortion in a single, low-power amplifier. The FDA is a flexible device, where the main aim is to provide a purely differential output signal centered on a user-configurable, common-mode voltage that is usually matched to the input common-mode voltage required by an analog-to-digital converter (ADC) or class-D amplifier. The circuit used for characterization of the differential-to-differential performance is seen in [Figure 7-1](#).

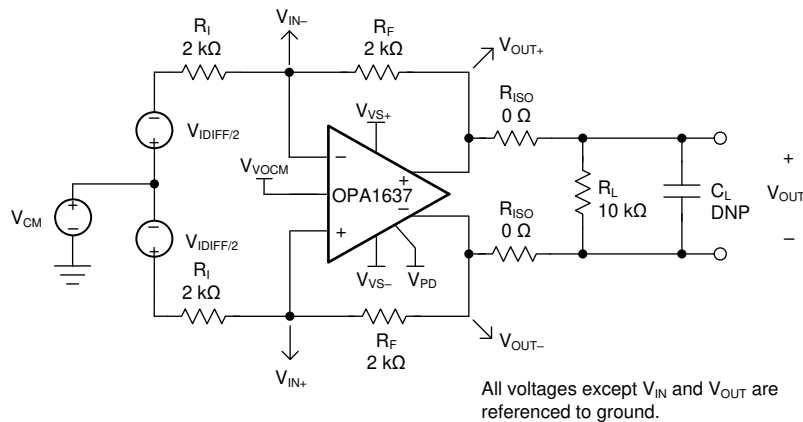

Figure 7-1. Differential Source to a Differential Gain of a 1-V/V Test Circuit

A similar circuit is used for single-ended to differential measurements, as shown in [Figure 7-2](#).

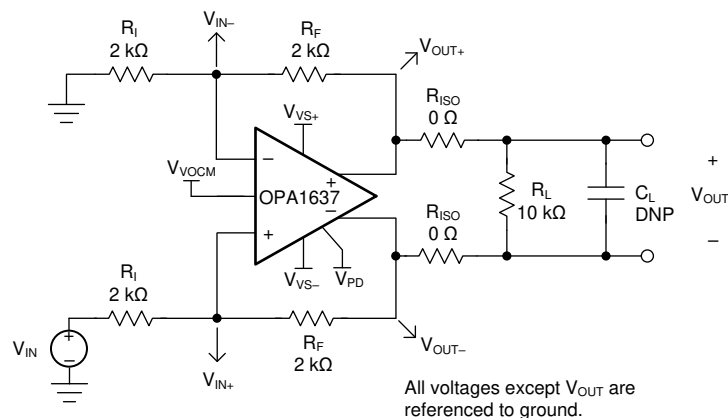

Figure 7-2. Single-Ended to Differential Gain of a 1-V/V Test Circuit

The FDA requires feedback resistor for both output pins to the input pins. These feedback resistors load the output differentially only if the input common-mode voltage is equal to the output common-mode voltage set by V_OCM. When V_OCM differs from the input common-mode range, the feedback resistors create single-ended loading. The characterization plots fix the R_F ($R_{F1} = R_{F2}$) value at 2 kΩ, unless otherwise noted. This value can be adjusted to match the system design parameters with the following considerations in mind:

- The current needed to drive R_F from the peak output voltage to the input common-mode voltage adds to the overall output load current. If the total load current (current through R_F + current through R_L) exceeds the current limit conditions, the device enters a current limit state, causing the output voltage to collapse.
- High feedback resistor values ($R_F > 100$ kΩ) interact with the amplifier input capacitance to create a zero in the feedback network. Compensation must be added to account for this potential source of instability; see the [TI Precision Labs FDA Stability Training](#) for guidance on designing an appropriate compensation network.

8 Detailed Description

8.1 Overview

The OPA1637 is a low-noise, low-distortion fully-differential amplifier (FDA) that features Texas Instrument's super-beta bipolar input devices. Super-beta input devices feature very low input bias current as compared to standard bipolar technology. The low input bias current and current noise makes the OPA1637 an excellent choice for audio applications that require low-noise differential signal processing without significant current consumption. This device is also designed for analog-to-digital audio input circuits that require low noise in a single fully-differential amplifier. This device achieves lower current consumption at lower noise levels than what is achievable with two low-noise amplifiers. The OPA1637 also features high-voltage capability, which allows the device to be used in $\pm 15\text{-V}$ supply circuits without any additional voltage clamping or regulators. This feature enables a direct, single amplifier for a 24-dBm differential output drive (commonly found on mixers and digital audio interfaces) without any additional amplification.

8.2 Functional Block Diagram

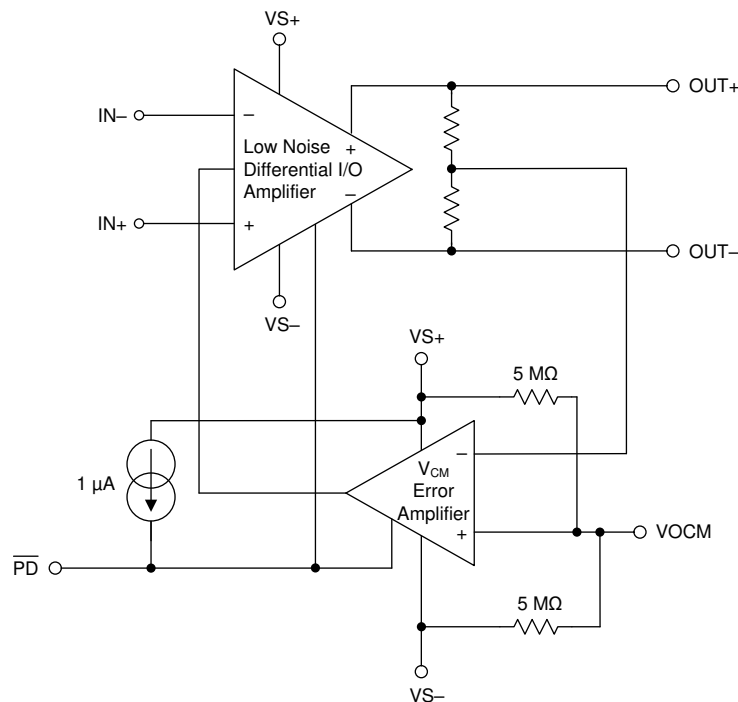

8.3 Feature Description

8.3.1 Super-Beta Input Bipolar Transistors

The OPA1637 is designed on a modern bipolar process that features TI's super-beta input transistors. Traditional bipolar transistors feature excellent voltage noise and offset drift, but suffer a tradeoff in high input bias current (I_B) and high input bias current noise. Super-beta transistors offer the benefits of low voltage noise and low offset drift with an order of magnitude reduction in input bias current and reduction in input bias current noise. For audio circuits, input bias current noise can dominate in circuits where higher resistance input resistors are used. The OPA1637 enables a fully-differential, low-noise amplifier design without restrictions of low input resistance at a power level unmatched by traditional single-ended amplifiers.

8.3.2 Power Down

The OPA1637 features a power-down circuit to disable the amplifier when a low-power mode is required by the system. In the power-down state, the amplifier outputs are in a high-impedance state, and the amplifier total quiescent current is reduced to less than 20 μA .

8.3.3 Flexible Gain Setting

The OPA1637 offers considerable flexibility in the configuration and selection of resistor values. Low input bias current and bias current noise allows for larger gain resistor values with minimal impact to noise or offset. The design starts with the selection of the feedback resistor value. The 2-k Ω feedback resistor value used for the characterization curves is a good compromise among power, noise, and phase margin considerations. With the feedback resistor values selected (and set equal on each side), the input resistors are set to obtain the desired gain, with the input impedance also set with these input resistors. Differential I/O designs provide an input impedance that is the sum of the two input resistors. Single-ended input to differential output designs present a more complicated input impedance. Most characteristic curves implement the single-ended to differential design as the more challenging requirement over differential-to-differential I/O.

8.3.4 Amplifier Overload Power Limit

In many bipolar-based amplifiers, the output stage of the amplifier can draw significant (several milliamperes) of quiescent current if the output voltage becomes clipped (meaning the output voltage becomes limited by the negative or positive supply voltage). This condition can cause the system to enter a high-power consumption state, and potentially cause oscillations between the power supply and signal chain. The OPA1637 has an advanced output stage design that eliminates this problem. When the output voltage reaches the V_{VS+} or V_{VS-} voltage, there is virtually no additional current consumption from the nominal quiescent current. This feature helps eliminate any potential system problems when the signal chain is disrupted by a large external transient voltage.

8.4 Device Functional Modes

The OPA1637 has two functional modes: normal operation and power-down. The power-down state is enabled when the voltage on the power-down pin is lowered to less than the power-down threshold. In the power-down state, the quiescent current is significantly reduced, and the output voltage is high-impedance. This high impedance can lead to the input voltages (+IN and -IN) separating, and forward-biasing the ESD protection diodes. See [Section 9](#) for guidance on power-down operation.

9 Application and Implementation

Note

Information in the following applications sections is not part of the TI component specification, and TI does not warrant its accuracy or completeness. TI's customers are responsible for determining suitability of components for their purposes. Customers should validate and test their design implementation to confirm system functionality.

9.1 Application Information

Most applications for the OPA1637 strive to deliver the best dynamic range in a design that delivers the desired signal processing along with adequate phase margin for the amplifier. The following sections detail some of the design issues with analysis and guidelines for improved performance.

9.1.1 Driving Capacitive Loads

The capacitive load of an ADC, or some other next-stage device, is commonly required to be driven. Directly connecting a capacitive load to the output pins of a closed-loop amplifier such as the OPA1637 can lead to an unstable response. One typical remedy to this instability is to add two small series resistors (R_{ISO}) at the outputs of the OPA1637 before the capacitive load. Good practice is to leave a place for the R_{ISO} elements in a board layout (a 0- Ω value initially) for later adjustment, in case the response appears unacceptable.

For applications where the OPA1637 is used as an output device to drive an unknown capacitive load, such as a cable, R_{ISO} is required. [Figure 9-1](#) shows the required R_{ISO} value for a 40-degree phase-margin response. The peak required R_{ISO} value occurs when C_L is between 500 pF and 1 nF. As C_L increases beyond 1 nF, the bandwidth response of the device reduces, resulting in a slower response but no major degradation in phase margin. For a typical cable type, such as Belden 8451, capacitive loading can vary from 340 pF (10-foot cable) to 1.7 nF (50-foot cable). Selecting R_{ISO} to be 100 Ω provides sufficient phase margin regardless of the cable length. R_{ISO} can also be used within the loop feedback of the amplifier; however, simulation must be used to verify the stability of the system.

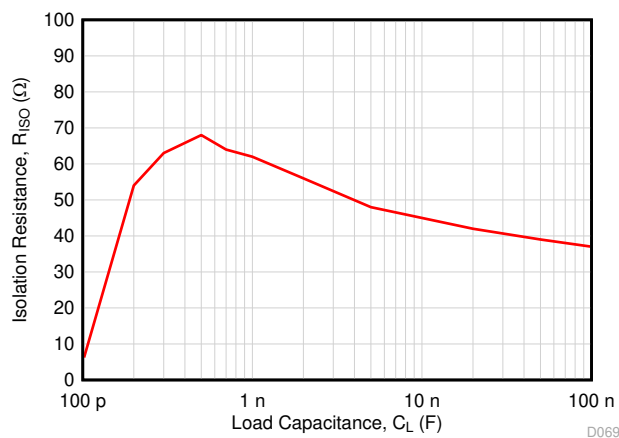

Figure 9-1. Required Isolation Resistance vs Capacitive Load for a 40° Phase Margin

9.1.2 Operating the Power-Down Feature

The power-down feature on the OPA1637 allows the device to be put into a low power-consumption state, in which quiescent current is minimized. To force the device into the low-power state, drive the $\overline{\text{PD}}$ pin lower than the power-down threshold voltage ($V_{\text{VS}+} - 2 \text{ V}$). Driving the PD pin lower than the power-down threshold voltage forces the internal logic to disable both the differential and common-mode amplifiers. The $\overline{\text{PD}}$ pin has an internal pullup current that allows the pin to be used in an open-drain MOSFET configuration without an additional pullup resistor, as seen in Figure 9-2. In this configuration, the logic level can be referenced to the MOSFET, and the voltage at the $\overline{\text{PD}}$ pin is level-shifted to account for use with high supply voltages. Be sure to select an N-type MOSFET with a maximum B_{VDSS} greater than the total supply voltage. For applications that do not use the power-down feature, tie the $\overline{\text{PD}}$ pin to the positive supply voltage.

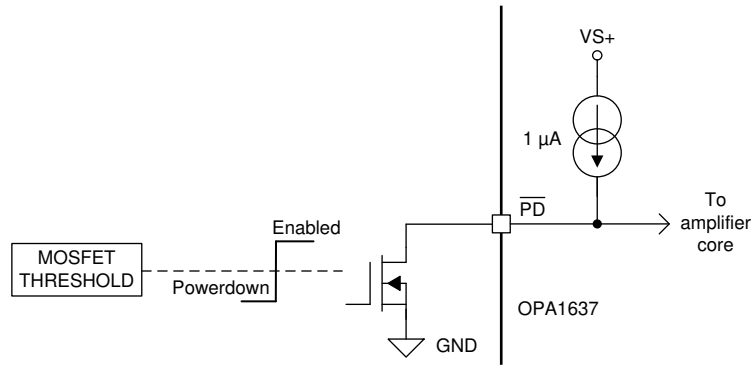

Figure 9-2. Power-Down ($\overline{\text{PD}}$) Pin Interface With Low-Voltage Logic Level Signals

When \overline{PD} is low (device is in power down) the output pins will be in a high-impedance state. When the device is in the power-down state, the outputs are high impedance, and the output voltage is no longer controlled by the amplifier, but dependant on the input and load configuration. In this case, the input voltage between $IN-$ and $IN+$ can drift to a voltage that may forward-bias the input protection diodes. Take care to avoid high currents flowing through the input diodes by using an input resistor to limit the current to less than 10 mA. In [Figure 9-3](#), the OPA1637 is configured in a differential gain of 5 with 100- Ω input resistors. When the device enters power down, the voltage between $IN-$ and $IN+$ increases until the internal protection diode is forward-biased. In this case, exceeding a voltage on V_{IN} with $R_{IN} = 0 \Omega$ of 2.5 V (diode forward voltage estimated at 0.5 V) results in a current greater than 10 mA. To avoid this high current, select R_{IN} so that the maximum current flow is less than 10 mA when V_{IN} is at maximum voltage.

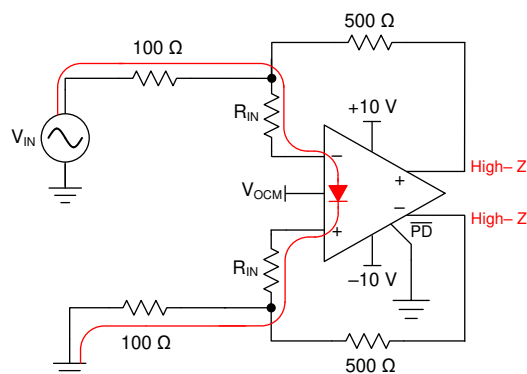

Figure 9-3. Path of Input Current Flow When $\overline{PD} = \text{Low}$

9.1.3 I/O Headroom Considerations

The starting point for most designs is to assign an output common-mode voltage for the OPA1637. For ac-coupled signal paths, this voltage is often the default midsupply voltage to retain the most available output swing around the voltage centered at the V_{OCM} voltage. For dc-coupled designs, set this voltage with consideration to the required minimum headroom to the supplies, as described in the specifications for the V_{OCM} control. For precision ADC drivers, this V_{OCM} output becomes the V_{CM} input to the ADC. Often, V_{CM} is set to $V_{REF} / 2$ to center the differential input on the available input when precision ADCs are being driven.

From target output V_{OCM} , the next step is to verify that the desired output differential peak-to-peak voltage, V_{OUTPP} , stays within the supplies. For any desired differential V_{OUTPP} , make sure that the absolute maximum voltage at the output pins swings with [Equation 1](#) and [Equation 2](#), and confirm that these expressions are within the supply rails minus the output headroom required for the RRO device.

$$V_{OUTMIN} = V_{OCM} - \frac{V_{OUTPP}}{4} \quad (1)$$

$$V_{OUTMAX} = V_{OCM} + \frac{V_{OUTPP}}{4} \quad (2)$$

With the output headroom confirmed, the input junctions must also stay within the operating range. The input range limitations require a maximum 1.0-V headroom from the supply voltages (V_{S+} and V_{S-}) over the full temperature range.

9.1.4 Noise Performance

The first step in the output noise analysis is to reduce the application circuit to the simplest form with equal feedback and gain setting elements to ground. Figure 9-4 shows the simplest analysis circuit with the FDA and resistor noise terms to be considered.

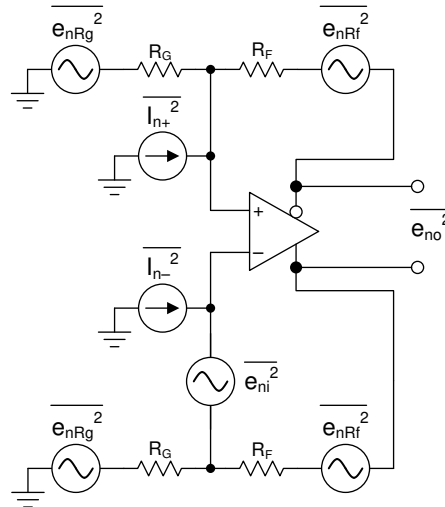

Figure 9-4. FDA Noise Analysis Circuit

The noise powers are shown in Figure 9-4 for each term. When the R_F and R_G (or R_I) terms are matched on each side, the total differential output noise is the root sum squared (RSS) of these separate terms. Using $NG \equiv 1 + R_F / R_G$, the total output noise is given by Equation 3. Each resistor noise term is a $4kT \times R$ power ($4kT = 1.6E-20$ J at 290 K).

$$e_o = \sqrt{(e_{ni}NG)^2 + 2(i_{n+}R_F)^2 + 2(4kTR_FNG)} \quad (3)$$

The first term is simply the differential input spot noise times the noise gain. The second term is the input current noise terms times the feedback resistor (and because there are two uncorrelated current noise terms, the power is two times one of them). The last term is the output noise resulting from both the R_F and R_G resistors, at again, twice the value for the output noise power of each side added together. Running a wide sweep of gains when holding R_F to 2 k Ω gives the standard values and resulting noise listed in Table 9-1. When the gain increases, the input-referred noise approaches only the gain of the FDA input voltage noise term at 3.7 nV/ $\sqrt{\text{Hz}}$.

Table 9-1. Swept Gain of the Output- and Input-Referred Spot Noise Calculations

| GAIN (V/V) | R_F (Ω) | R_{G1} (Ω) | A_V | E_O (nV/ $\sqrt{\text{Hz}}$) | E_I (nV/ $\sqrt{\text{Hz}}$) |
|------------|--------------------|-----------------------|-------|---------------------------------|---------------------------------|
| 0.1 | 2000 | 20000 | 0.1 | 9.4 | 93.9 |
| 1 | 2000 | 2000 | 1 | 13.6 | 13.6 |
| 2 | 2000 | 1000 | 2 | 17.8 | 8.9 |
| 5 | 2000 | 402 | 4.98 | 29.5 | 5.9 |
| 10 | 2000 | 200 | 10 | 48.6 | 4.9 |

9.2 Typical Applications

9.2.1 Current-Output Audio DAC Buffer to Class-D Amplifier

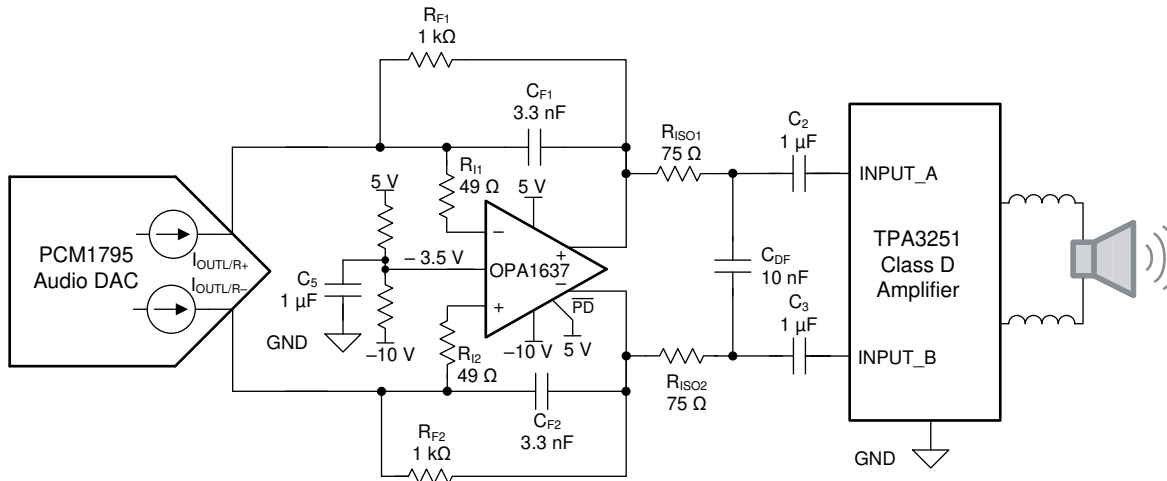

Figure 9-5. Differential Current-to-Voltage Converter

9.2.1.1 Design Requirements

The requirements for this application are:

- Differential current-to-voltage conversion and filtering
- 1-kmho transimpedance gain
- 40-kHz Butterworth response filter
- 0-V dc common-mode voltage at DAC output

9.2.1.2 Detailed Design Procedure

This design provides current-to-voltage conversion from a current-output audio DAC into a voltage-input, class-D amplifier. The order of design priorities are as follows:

- Select feedback-resistor values based on the gain required from the current-output stage to the voltage-input stage. For this design, the full-scale, peak-to-peak output current of the [PCM1795](#) ($I_{OUTL/R+} - I_{OUTL/R-}$) is ± 4 mA. A gain of 1k gives a wide voltage swing of ± 4 V, allowing for high SNR without exceeding the input voltage limit of the [TPA3251](#).
- After the gain is fixed, select the output common-mode voltage. The output common-mode voltage determines the input common-mode voltage in this configuration. To set the nominal output voltage of the PCM1795 to 0 V (which corresponds to the input common mode voltage of the OPA1637), shift the output negatively from the desired common-mode input voltage by the gain multiplied by the dc center current value of the PCM1795 (3.5 mA). In this case, -3.5 V satisfies the design goal.
- A bypass capacitor from the VOVM pin to ground must be selected to filter noise from the voltage divider. The capacitor selection is determined by balancing the startup time of the system with the output common-mode noise. A higher capacitance gives a lower frequency filter cutoff on the VOVM pin, thus giving lower noise performance, but also slows down the initial startup time of the circuit as a result of the RC delay from the resistor divider in combination with the filter capacitor.
- Select C_F so that the desired bandwidth of the active filter is achieved. The 3-dB frequency is determined by the reciprocal of the product of R_F and C_F .
- Use a passive filter on the output to increase noise filtering beyond the desired bandwidth. The passive filter formed by $R_{D1,2}$ and C_{DF} adds an additional real pole to the filter response. If the pole is designed at the same frequency as the active filter pole, the overall 3-dB frequency shifts to a lower frequency value, and the step response is overdamped. A trade-off must be made to give optimal transient response versus increased filter attenuation at higher frequencies. For this design, the second pole is set to 106 kHz.

9.2.1.3 Application Curves

The simulated response of the current-to-voltage audio DAC buffer can be seen in [Figure 9-6](#) and [Figure 9-7](#).

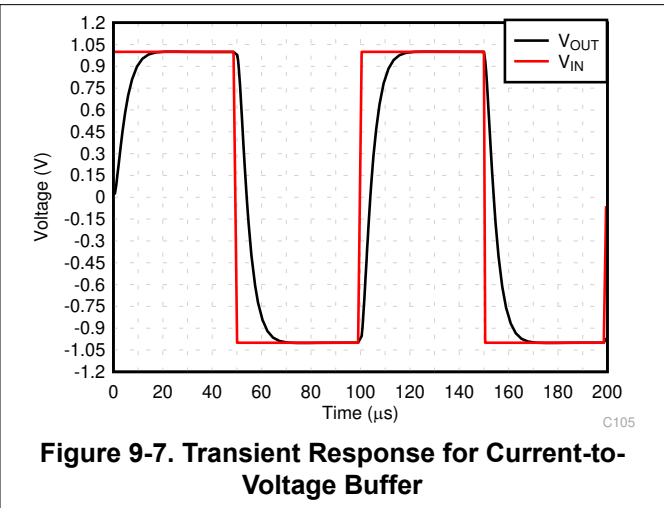
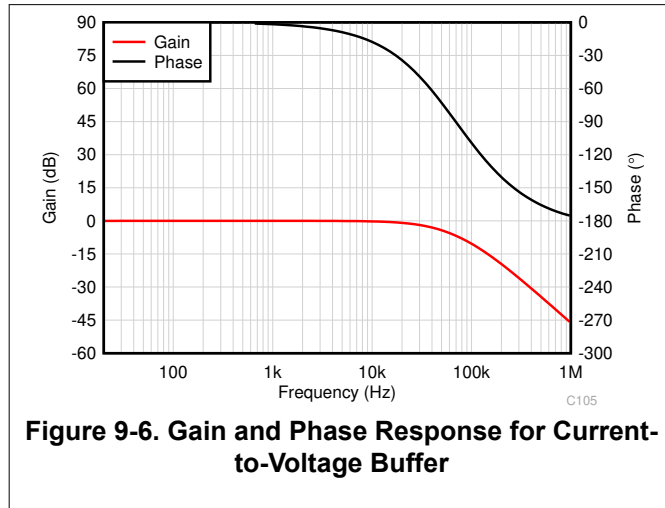

9.2.2 An MFB Filter Driving an ADC Application

A common application use case for fully-differential amplifiers is to easily convert a single-ended signal into a differential signal to drive a differential input source, such as an ADC or class-D amplifier. Figure 9-8 shows an example of the OPA1637 used to convert a single-ended, low-voltage signal audio source, such as a small electret microphone, and deliver a low-noise differential signal that is common-mode shifted to the center of the ADC input range. A multiple-feedback (MFB) configuration is used to provide a Butterworth filter response, giving a 40-dB/decade rolloff with a -3 -dB frequency of 30 kHz.

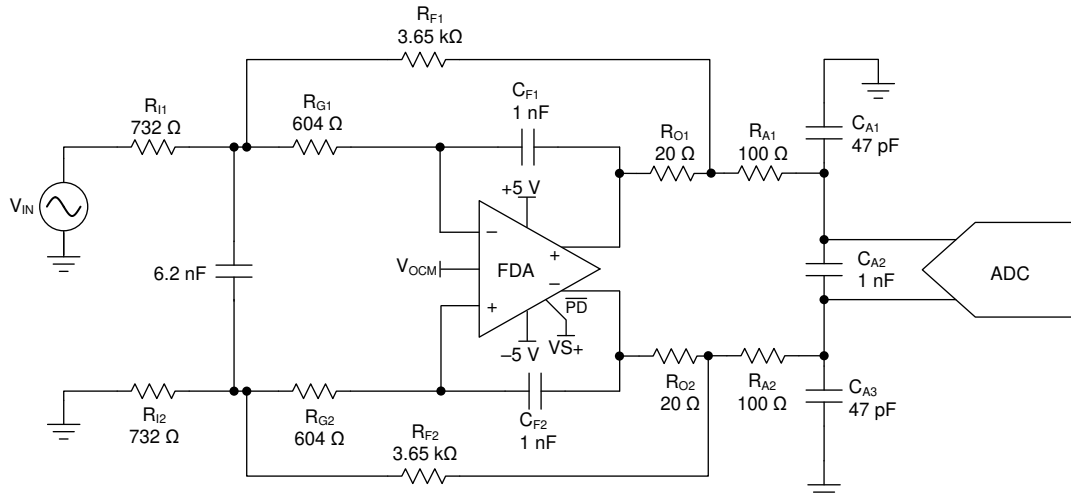

Figure 9-8. Example 30-kHz Butterworth Filter

9.2.2.1 Design Requirements

The requirements for this application are:

- Single-ended to differential conversion
- 5-V/V gain
- Active filter set to a Butterworth, 30-kHz response shape
- Output RC elements set by SAR input requirements (not part of the filter design)
- Filter element resistors and capacitors are set to limit added noise over the OPA1637 and noise peaking

9.2.2.2 Detailed Design Procedure

The design proceeds using the techniques and tools suggested in the [Design Methodology for MFB Filters in ADC Interface Applications application note](#). The process includes:

- Scale the resistor values to not meaningfully contribute to the output noise produced by the OPA1637.
- Select the RC ratios to hit the filter targets when reducing the noise gain peaking within the filter design.
- Set the output resistor to 100 Ω into a 1-nF differential capacitor.
- Add 47-pF common-mode capacitors to the load capacitor to improve common noise filtering.
- Inside the loop, add 20- Ω output resistors after the filter feedback capacitor to increase the isolation to the load capacitor.

9.2.2.3 Application Curves

The gain and phase plots are shown in [Figure 9-9](#). The MFB filter features a Butterworth responses feature very flat passband gain, with a 2-pole roll-off at 30 kHz to eliminate any higher-frequency noise from contaminating the signal chain, and potentially alias back into the audio band.

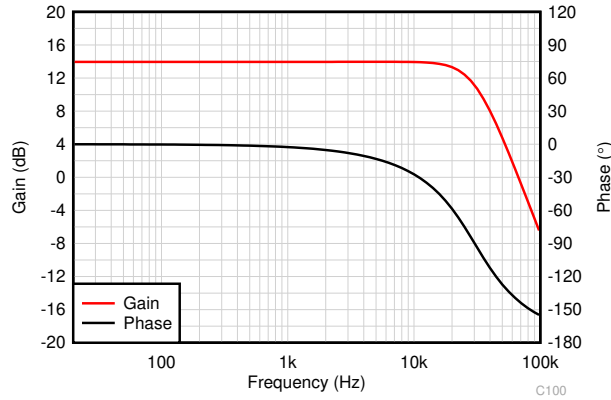

Figure 9-9. Gain and Phase Plot for a 30-kHz Butterworth Filter

9.2.3 Differential Microphone Input to Line Level

Professional dynamic microphones typically feature low output impedance to minimize noise coupling on the microphone cable. Interfacing the microphone with high-impedance circuitry typically requires the use of an impedance conversion stage, often done with a transformer or discrete amplifiers. The flexibility of the OPA1637 allows the device to be configured with a low differential input impedance and 20 dB of gain, simplifying the impedance conversion and gain stage into a single device. Figure 9-10 shows an example of a differential, low input impedance, microphone level voltage (10 mV to 100 mV) amplifier to a line-level amplitude signal that also has adjustable dc common-mode shift capability. This design example shows how the OPA1637 makes a great choice for driving an ADC class-D amplifier.

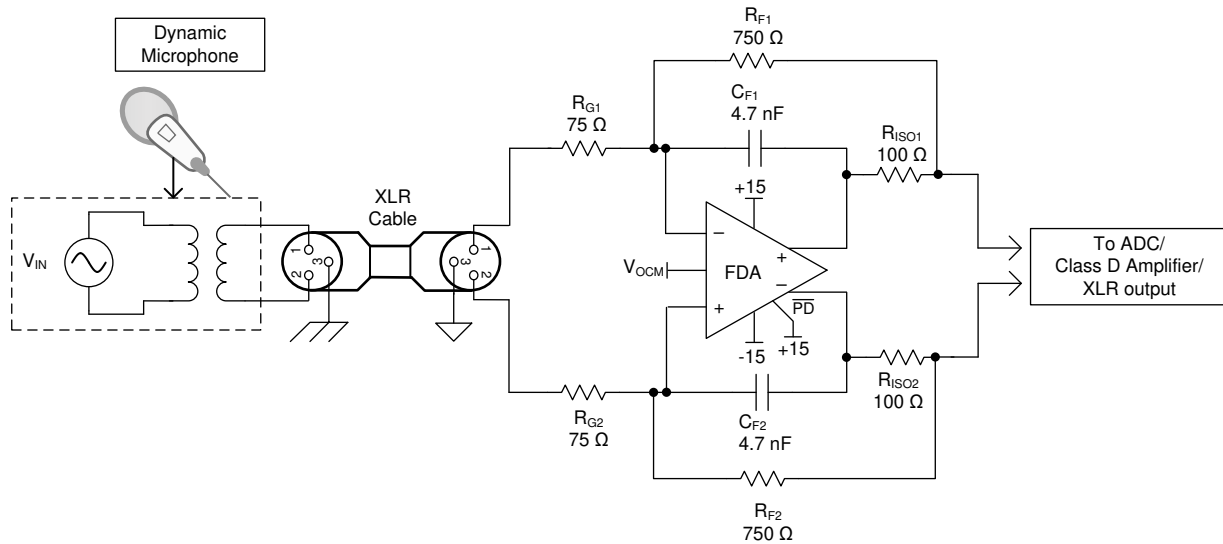

Figure 9-10. Fully Differential, Low-Noise, 20-dB Microphone Gain Block With DC Shift

9.2.3.1 Application Curves

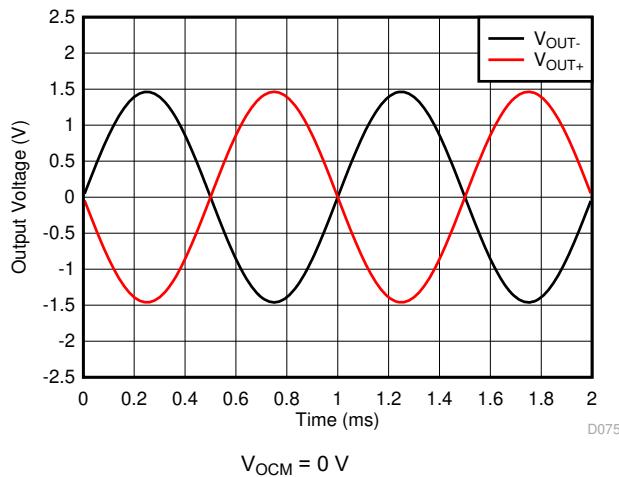

Figure 9-11. Output Waveform of the Microphone Amplifier

10 Power Supply Recommendations

The OPA1637 operates from supply voltages of 3.0 V to 36 V (± 1.5 V to ± 18 V, dual supply). Connect ceramic bypass capacitors from both VS+ and VS– to GND.

11 Layout

11.1 Layout Guidelines

11.1.1 Board Layout Recommendations

- Keep differential signals routed together to minimize parasitic impedance mismatch.
- Connect a 0.1- μ F capacitor to the supply nodes through a via.
- Connect a 0.1- μ F capacitor to the VO_{CM} pin if no external voltage is used.
- Keep any high-frequency nodes that can couple through parasitic paths away from the VO_{CM} node.
- Clean the PCB board after assembly to minimize any leakage paths from excess flux into the VO_{CM} node.

11.2 Layout Example

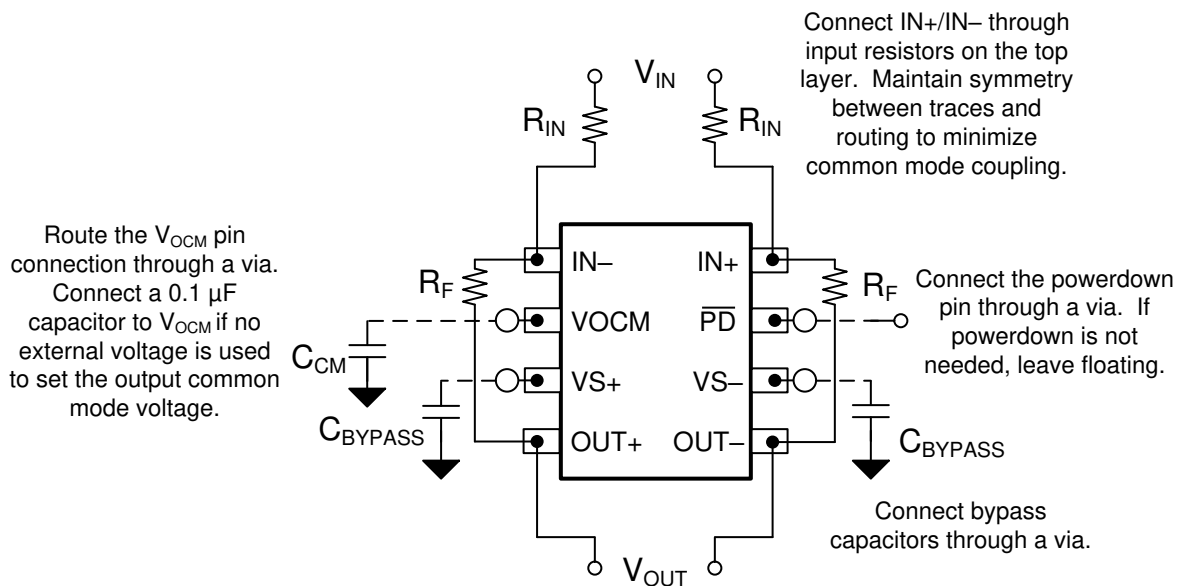

Figure 11-1. Example Layout

12 Device and Documentation Support

12.1 Device Support

12.1.1 Development Support

- [OPA1637 TINA-TI™ model](#)
- [TINA-TI Gain of 0.2 100kHz Butterworth MFB Filter](#)
- [TINA-TI 100kHz MFB filter LG test](#)
- [TINA-TI Differential Transimpedance LG Sim](#)

12.2 Documentation Support

12.2.1 Related Documentation

For related documentation see the following:

- Texas Instruments, [OPAx192 36-V, Precision, Rail-to-Rail Input/Output, Low Offset Voltage, Low Input Bias Current Op Amp with e-trim™ data sheet](#)
- Texas Instruments, [OPA161x SoundPlus™ High-Performance, Bipolar-Input Audio Operational Amplifiers data sheet](#)
- Texas Instruments, [Design Methodology for MFB Filters in ADC Interface Applications application report](#)
- Texas Instruments, [Design for Wideband Differential Transimpedance DAC Output application report](#)
- Texas Instruments, [PCM1795 32-Bit, 192-kHz Sampling, Advanced Segment, Stereo Audio Digital-to-Analog Converter data sheet](#)
- Texas Instruments, [TPA3251 175-W Stereo, 350-W Mono PurePath™ Ultra-HD Analog Input Class-D Amplifier data sheet](#)

12.3 Receiving Notification of Documentation Updates

To receive notification of documentation updates, navigate to the device product folder on ti.com. Click on *Subscribe to updates* to register and receive a weekly digest of any product information that has changed. For change details, review the revision history included in any revised document.

12.4 Support Resources

[TI E2E™ support forums](#) are an engineer's go-to source for fast, verified answers and design help — straight from the experts. Search existing answers or ask your own question to get the quick design help you need.

Linked content is provided "AS IS" by the respective contributors. They do not constitute TI specifications and do not necessarily reflect TI's views; see TI's [Terms of Use](#).

12.5 Trademarks

Burr-Brown™ and TI E2E™ are trademarks of Texas Instruments. All other trademarks are the property of their respective owners.

12.6 Electrostatic Discharge Caution



This integrated circuit can be damaged by ESD. Texas Instruments recommends that all integrated circuits be handled with appropriate precautions. Failure to observe proper handling and installation procedures can cause damage.

ESD damage can range from subtle performance degradation to complete device failure. Precision integrated circuits may be more susceptible to damage because very small parametric changes could cause the device not to meet its published specifications.

12.7 Glossary

[TI Glossary](#) This glossary lists and explains terms, acronyms, and definitions.

13 Mechanical, Packaging, and Orderable Information

The following pages include mechanical, packaging, and orderable information. This information is the most current data available for the designated devices. This data is subject to change without notice and revision of this document. For browser-based versions of this data sheet, refer to the left-hand navigation.

PACKAGING INFORMATION

| Orderable part number | Status (1) | Material type (2) | Package Pins | Package qty Carrier | RoHS (3) | Lead finish/ Ball material (4) | MSL rating/ Peak reflow (5) | Op temp (°C) | Part marking (6) |
|-----------------------------|---------------|----------------------|-----------------|-----------------------|-------------|--------------------------------------|-----------------------------------|--------------|---------------------|
| OPA1637DGKR | Active | Production | VSSOP (DGK) 8 | 2500 LARGE T&R | Yes | NIPDAU SN NIPDAUAG | Level-2-260C-1 YEAR | -40 to 125 | 1637 |
| OPA1637DGKR.B | Active | Production | VSSOP (DGK) 8 | 2500 LARGE T&R | Yes | NIPDAU | Level-2-260C-1 YEAR | -40 to 125 | 1637 |
| OPA1637DGKRG4 | Active | Production | VSSOP (DGK) 8 | 2500 LARGE T&R | Yes | NIPDAU | Level-2-260C-1 YEAR | -40 to 125 | 1637 |
| OPA1637DGKRG4.B | Active | Production | VSSOP (DGK) 8 | 2500 LARGE T&R | Yes | NIPDAU | Level-2-260C-1 YEAR | -40 to 125 | 1637 |
| OPA1637DGKT | Active | Production | VSSOP (DGK) 8 | 250 SMALL T&R | Yes | NIPDAU SN NIPDAUAG | Level-2-260C-1 YEAR | -40 to 125 | 1637 |
| OPA1637DGKT.B | Active | Production | VSSOP (DGK) 8 | 250 SMALL T&R | Yes | NIPDAU | Level-2-260C-1 YEAR | -40 to 125 | 1637 |

(1) **Status:** For more details on status, see our [product life cycle](#).

(2) **Material type:** When designated, preproduction parts are prototypes/experimental devices, and are not yet approved or released for full production. Testing and final process, including without limitation quality assurance, reliability performance testing, and/or process qualification, may not yet be complete, and this item is subject to further changes or possible discontinuation. If available for ordering, purchases will be subject to an additional waiver at checkout, and are intended for early internal evaluation purposes only. These items are sold without warranties of any kind.

(3) **RoHS values:** Yes, No, RoHS Exempt. See the [TI RoHS Statement](#) for additional information and value definition.

(4) **Lead finish/Ball material:** Parts may have multiple material finish options. Finish options are separated by a vertical ruled line. Lead finish/Ball material values may wrap to two lines if the finish value exceeds the maximum column width.

(5) **MSL rating/Peak reflow:** The moisture sensitivity level ratings and peak solder (reflow) temperatures. In the event that a part has multiple moisture sensitivity ratings, only the lowest level per JEDEC standards is shown. Refer to the shipping label for the actual reflow temperature that will be used to mount the part to the printed circuit board.

(6) **Part marking:** There may be an additional marking, which relates to the logo, the lot trace code information, or the environmental category of the part.

Multiple part markings will be inside parentheses. Only one part marking contained in parentheses and separated by a "~" will appear on a part. If a line is indented then it is a continuation of the previous line and the two combined represent the entire part marking for that device.

Important Information and Disclaimer: The information provided on this page represents TI's knowledge and belief as of the date that it is provided. TI bases its knowledge and belief on information provided by third parties, and makes no representation or warranty as to the accuracy of such information. Efforts are underway to better integrate information from third parties. TI has taken and continues to take reasonable steps to provide representative and accurate information but may not have conducted destructive testing or chemical analysis on incoming materials and chemicals. TI and TI suppliers consider certain information to be proprietary, and thus CAS numbers and other limited information may not be available for release.

In no event shall TI's liability arising out of such information exceed the total purchase price of the TI part(s) at issue in this document sold by TI to Customer on an annual basis.

TAPE AND REEL INFORMATION

QUADRANT ASSIGNMENTS FOR PIN 1 ORIENTATION IN TAPE

*All dimensions are nominal

| Device | Package Type | Package Drawing | Pins | SPQ | Reel Diameter (mm) | Reel Width W1 (mm) | A0 (mm) | B0 (mm) | K0 (mm) | P1 (mm) | W (mm) | Pin1 Quadrant |
|---------------|--------------|-----------------|------|------|--------------------|--------------------|---------|---------|---------|---------|--------|---------------|
| OPA1637DGKR | VSSOP | DGK | 8 | 2500 | 330.0 | 12.4 | 5.3 | 3.4 | 1.4 | 8.0 | 12.0 | Q1 |
| OPA1637DGKRG4 | VSSOP | DGK | 8 | 2500 | 330.0 | 12.4 | 5.3 | 3.4 | 1.4 | 8.0 | 12.0 | Q1 |
| OPA1637DGKT | VSSOP | DGK | 8 | 250 | 330.0 | 12.4 | 5.3 | 3.4 | 1.4 | 8.0 | 12.0 | Q1 |
| OPA1637DGKT | VSSOP | DGK | 8 | 250 | 330.0 | 12.4 | 5.25 | 3.35 | 1.25 | 8.0 | 12.0 | Q1 |
| OPA1637DGKT | VSSOP | DGK | 8 | 250 | 330.0 | 12.4 | 5.3 | 3.4 | 1.4 | 8.0 | 12.0 | Q1 |

TAPE AND REEL BOX DIMENSIONS



*All dimensions are nominal

| Device | Package Type | Package Drawing | Pins | SPQ | Length (mm) | Width (mm) | Height (mm) |
|---------------|--------------|-----------------|------|------|-------------|------------|-------------|
| OPA1637DGKR | VSSOP | DGK | 8 | 2500 | 353.0 | 353.0 | 32.0 |
| OPA1637DGKRG4 | VSSOP | DGK | 8 | 2500 | 353.0 | 353.0 | 32.0 |
| OPA1637DGKT | VSSOP | DGK | 8 | 250 | 366.0 | 364.0 | 50.0 |
| OPA1637DGKT | VSSOP | DGK | 8 | 250 | 366.0 | 364.0 | 50.0 |
| OPA1637DGKT | VSSOP | DGK | 8 | 250 | 353.0 | 353.0 | 32.0 |

DGK0008A



PACKAGE OUTLINE

VSSOP - 1.1 mm max height

SMALL OUTLINE PACKAGE



4214862/A 04/2023

PowerPAD is a trademark of Texas Instruments.

NOTES:

- All linear dimensions are in millimeters. Any dimensions in parenthesis are for reference only. Dimensioning and tolerancing per ASME Y14.5M.
- This drawing is subject to change without notice.
- This dimension does not include mold flash, protrusions, or gate burrs. Mold flash, protrusions, or gate burrs shall not exceed 0.15 mm per side.
- This dimension does not include interlead flash. Interlead flash shall not exceed 0.25 mm per side.
- Reference JEDEC registration MO-187.

EXAMPLE BOARD LAYOUT

DGK0008A

™ VSSOP - 1.1 mm max height

SMALL OUTLINE PACKAGE



LAND PATTERN EXAMPLE
EXPOSED METAL SHOWN
SCALE: 15X



SOLDER MASK DETAILS

4214862/A 04/2023

NOTES: (continued)

6. Publication IPC-7351 may have alternate designs.
7. Solder mask tolerances between and around signal pads can vary based on board fabrication site.
8. Vias are optional depending on application, refer to device data sheet. If any vias are implemented, refer to their locations shown on this view. It is recommended that vias under paste be filled, plugged or tented.
9. Size of metal pad may vary due to creepage requirement.

EXAMPLE STENCIL DESIGN

DGK0008A

TM VSSOP - 1.1 mm max height

SMALL OUTLINE PACKAGE



SOLDER PASTE EXAMPLE
SCALE: 15X

4214862/A 04/2023

NOTES: (continued)

11. Laser cutting apertures with trapezoidal walls and rounded corners may offer better paste release. IPC-7525 may have alternate design recommendations.
12. Board assembly site may have different recommendations for stencil design.

IMPORTANT NOTICE AND DISCLAIMER

TI PROVIDES TECHNICAL AND RELIABILITY DATA (INCLUDING DATASHEETS), DESIGN RESOURCES (INCLUDING REFERENCE DESIGNS), APPLICATION OR OTHER DESIGN ADVICE, WEB TOOLS, SAFETY INFORMATION, AND OTHER RESOURCES "AS IS" AND WITH ALL FAULTS, AND DISCLAIMS ALL WARRANTIES, EXPRESS AND IMPLIED, INCLUDING WITHOUT LIMITATION ANY IMPLIED WARRANTIES OF MERCHANTABILITY, FITNESS FOR A PARTICULAR PURPOSE OR NON-INFRINGEMENT OF THIRD PARTY INTELLECTUAL PROPERTY RIGHTS.

These resources are intended for skilled developers designing with TI products. You are solely responsible for (1) selecting the appropriate TI products for your application, (2) designing, validating and testing your application, and (3) ensuring your application meets applicable standards, and any other safety, security, regulatory or other requirements.

These resources are subject to change without notice. TI grants you permission to use these resources only for development of an application that uses the TI products described in the resource. Other reproduction and display of these resources is prohibited. No license is granted to any other TI intellectual property right or to any third party intellectual property right. TI disclaims responsibility for, and you fully indemnify TI and its representatives against any claims, damages, costs, losses, and liabilities arising out of your use of these resources.

TI's products are provided subject to [TI's Terms of Sale](#), [TI's General Quality Guidelines](#), or other applicable terms available either on ti.com or provided in conjunction with such TI products. TI's provision of these resources does not expand or otherwise alter TI's applicable warranties or warranty disclaimers for TI products. Unless TI explicitly designates a product as custom or customer-specified, TI products are standard, catalog, general purpose devices.

TI objects to and rejects any additional or different terms you may propose.

Copyright © 2026, Texas Instruments Incorporated

Last updated 10/2025