

LP8764-Q1 Four-Phase, 20-A Buck Converter With Integrated Switches

1 Features

- AEC-Q100 Qualified with the following results:
 - Input voltage: 2.8 V to 5.5 V
 - Device temperature grade 1: -40°C to $+125^{\circ}\text{C}$ ambient operating temperature range
 - Device HBM ESD classification Level 2
 - Device CDM ESD classification Level C4B
- Functional Safety-Compliant
 - Developed for functional safety applications
 - Documentation available to aid ISO 26262 system design up to ASIL-D
 - Documentation available to aid IEC 61508 system design up to SIL-3
 - Systematic capability up to ASIL-D
 - Hardware integrity up to ASIL-D
 - Windowed voltage and over-current monitors
 - Watchdog with selectable trigger / Q&A mode
 - Level or PWM error signal monitoring (ESM)
 - Thermal monitoring with high temperature warning and thermal shutdown
 - Bit-integrity (CRC) error detection on configuration registers and non-volatile memory
- 4 high-efficiency step-down DC/DC converters:
 - Output voltage: 0.3 V to 3.34 V (0.3 V to 1.9 V for multi-phase outputs)
 - Maximum output current: 5 A per phase, up to 20 A with 4-phase configuration
 - Programmable output voltage slew-rate: 0.5 mV/ μs to 33 mV/ μs
 - Switching frequency: 2.2 MHz or 4.4 MHz
- 10 configurable general purpose I/O (GPIO)
- SPMI interface for multi-PMIC synchronization
- Input overvoltage monitor (OVP) and undervoltage lockout (UVLO)

2 Applications

- [Advanced driver assistance systems \(ADAS\)](#)
- [Front camera](#)
- [Surround view system ECU](#)
- [Long range radar](#)
- [Sensor fusion](#)
- [Domain controller](#)

3 Description

The LP8764-Q1 device is designed to meet the power management requirements of the latest processors and platforms in various safety-relevant automotive and industrial applications. The device has four step-down DC/DC converter cores, that are configurable for five different phase configurations from one 4-phase output to four 1-phase outputs. The device settings can be changed by I²C-compatible serial interface or by a SPI serial interface.

The automatic PFM/PWM (AUTO mode) operation together with the automatic phase adding and phase shedding maximizes efficiency over a wide output-current range. The LP8764-Q1 device supports remote differential voltage sensing for multiphase outputs to compensate IR drop between the regulator output and the point-of-load (POL) that improves the accuracy of the output voltage. The switching clock can be forced to PWM mode and the phases are interleaved. The switching can be synchronized to an external clock and spread-spectrum mode can be enabled to minimize the disturbances.

Device Information

PART NUMBER	PACKAGE ⁽¹⁾	BODY SIZE (NOM)
LP8764-Q1	VQFN-HR (32)	5.50mm × 5.00mm

- (1) For all available packages, see the orderable addendum at the end of the data sheet.

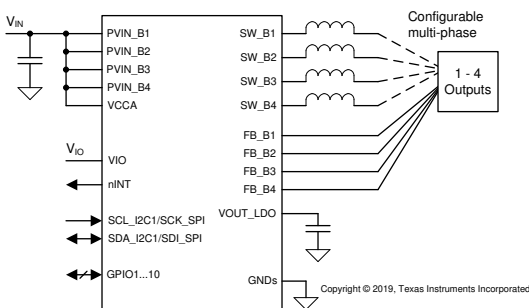

Simplified Schematic

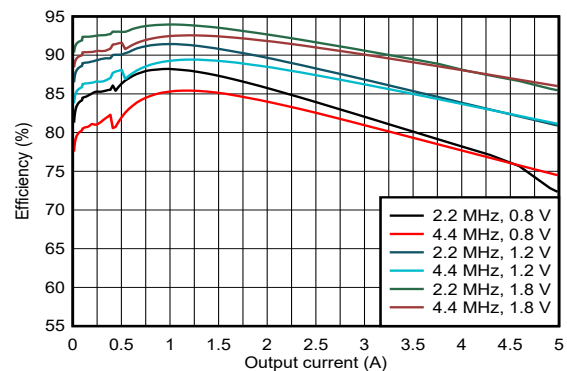

Efficiency vs Output Current (1-phase), $V_{IN} = 3.3\text{V}$



Table of Contents

1 Features	1	4.3 Trademarks.....	3
2 Applications	1	4.4 Electrostatic Discharge Caution.....	3
3 Description	1	4.5 Glossary.....	3
4 Device and Documentation Support	3	5 Revision History	3
4.1 Receiving Notification of Documentation Updates.....	3	6 Mechanical, Packaging, and Orderable Information	3
4.2 Support Resources.....	3		

4 Device and Documentation Support

4.1 Receiving Notification of Documentation Updates

To receive notification of documentation updates, navigate to the device product folder on [ti.com](https://www.ti.com). Click on *Notifications* to register and receive a weekly digest of any product information that has changed. For change details, review the revision history included in any revised document.

4.2 Support Resources

[TI E2E™ support forums](#) are an engineer's go-to source for fast, verified answers and design help — straight from the experts. Search existing answers or ask your own question to get the quick design help you need.

Linked content is provided "AS IS" by the respective contributors. They do not constitute TI specifications and do not necessarily reflect TI's views; see TI's [Terms of Use](#).

4.3 Trademarks

TI E2E™ is a trademark of Texas Instruments.
All trademarks are the property of their respective owners.

4.4 Electrostatic Discharge Caution



This integrated circuit can be damaged by ESD. Texas Instruments recommends that all integrated circuits be handled with appropriate precautions. Failure to observe proper handling and installation procedures can cause damage.

ESD damage can range from subtle performance degradation to complete device failure. Precision integrated circuits may be more susceptible to damage because very small parametric changes could cause the device not to meet its published specifications.

4.5 Glossary

[TI Glossary](#) This glossary lists and explains terms, acronyms, and definitions.

5 Revision History

NOTE: Page numbers for previous revisions may differ from page numbers in the current version.

DATE	REVISION	NOTES
November 2024	*	Initial Release

6 Mechanical, Packaging, and Orderable Information

The following pages include mechanical, packaging, and orderable information. This information is the most current data available for the designated devices. This data is subject to change without notice and revision of this document. For browser-based versions of this data sheet, refer to the left-hand navigation.

PACKAGING INFORMATION

Orderable part number	Status (1)	Material type (2)	Package Pins	Package qty Carrier	RoHS (3)	Lead finish/ Ball material (4)	MSL rating/ Peak reflow (5)	Op temp (°C)	Part marking (6)
LP876411B4RQKRQ1	Active	Production	VQFN-HR (RQK) 32	3000 LARGE T&R	Yes	SN	Level-2-260C-1 YEAR	-40 to 125	LP8764 11B4-Q1
LP876411B4RQKRQ1.A	Active	Production	VQFN-HR (RQK) 32	3000 LARGE T&R	Yes	SN	Level-2-260C-1 YEAR	-40 to 125	LP8764 11B4-Q1
LP876411B5RQKRQ1	Active	Production	VQFN-HR (RQK) 32	3000 LARGE T&R	Yes	SN	Level-2-260C-1 YEAR	-40 to 125	LP8764 11B5-Q1
LP876411B5RQKRQ1.A	Active	Production	VQFN-HR (RQK) 32	3000 LARGE T&R	Yes	SN	Level-2-260C-1 YEAR	-40 to 125	LP8764 11B5-Q1
LP876429CFRQKRQ1	Active	Production	VQFN-HR (RQK) 32	3000 LARGE T&R	Yes	SN	Level-2-260C-1 YEAR	-40 to 125	LP8764 29CF-Q1
LP876440C0RQKRQ1	Active	Production	VQFN-HR (RQK) 32	3000 LARGE T&R	Yes	SN	Level-2-260C-1 YEAR	-40 to 125	LP8764 40C0-Q1
LP876440C0RQKRQ1.A	Active	Production	VQFN-HR (RQK) 32	3000 LARGE T&R	Yes	SN	Level-2-260C-1 YEAR	-40 to 125	LP8764 40C0-Q1
LP876441B1RQKRQ1	Active	Production	VQFN-HR (RQK) 32	3000 LARGE T&R	Yes	NIPDAU SN	Level-2-260C-1 YEAR	-40 to 125	LP8764 41B1-Q1
LP876441B1RQKRQ1.A	Active	Production	VQFN-HR (RQK) 32	3000 LARGE T&R	Yes	NIPDAU	Level-2-260C-1 YEAR	-40 to 125	LP8764 41B1-Q1
LP876449CERQKRQ1	Active	Production	VQFN-HR (RQK) 32	3000 LARGE T&R	Yes	SN	Level-2-260C-1 YEAR	-40 to 125	LP8764 49CE-Q1
LP876459CDRQKRQ1	Active	Production	VQFN-HR (RQK) 32	3000 LARGE T&R	Yes	SN	Level-2-260C-1 YEAR	-40 to 125	LP8764 59CD-Q1

(1) **Status:** For more details on status, see our [product life cycle](#).

(2) **Material type:** When designated, preproduction parts are prototypes/experimental devices, and are not yet approved or released for full production. Testing and final process, including without limitation quality assurance, reliability performance testing, and/or process qualification, may not yet be complete, and this item is subject to further changes or possible discontinuation. If available for ordering, purchases will be subject to an additional waiver at checkout, and are intended for early internal evaluation purposes only. These items are sold without warranties of any kind.

(3) **RoHS values:** Yes, No, RoHS Exempt. See the [TI RoHS Statement](#) for additional information and value definition.

(4) **Lead finish/Ball material:** Parts may have multiple material finish options. Finish options are separated by a vertical ruled line. Lead finish/Ball material values may wrap to two lines if the finish value exceeds the maximum column width.

⁽⁵⁾ **MSL rating/Peak reflow:** The moisture sensitivity level ratings and peak solder (reflow) temperatures. In the event that a part has multiple moisture sensitivity ratings, only the lowest level per JEDEC standards is shown. Refer to the shipping label for the actual reflow temperature that will be used to mount the part to the printed circuit board.

⁽⁶⁾ **Part marking:** There may be an additional marking, which relates to the logo, the lot trace code information, or the environmental category of the part.

Multiple part markings will be inside parentheses. Only one part marking contained in parentheses and separated by a "~" will appear on a part. If a line is indented then it is a continuation of the previous line and the two combined represent the entire part marking for that device.

Important Information and Disclaimer: The information provided on this page represents TI's knowledge and belief as of the date that it is provided. TI bases its knowledge and belief on information provided by third parties, and makes no representation or warranty as to the accuracy of such information. Efforts are underway to better integrate information from third parties. TI has taken and continues to take reasonable steps to provide representative and accurate information but may not have conducted destructive testing or chemical analysis on incoming materials and chemicals. TI and TI suppliers consider certain information to be proprietary, and thus CAS numbers and other limited information may not be available for release.

In no event shall TI's liability arising out of such information exceed the total purchase price of the TI part(s) at issue in this document sold by TI to Customer on an annual basis.

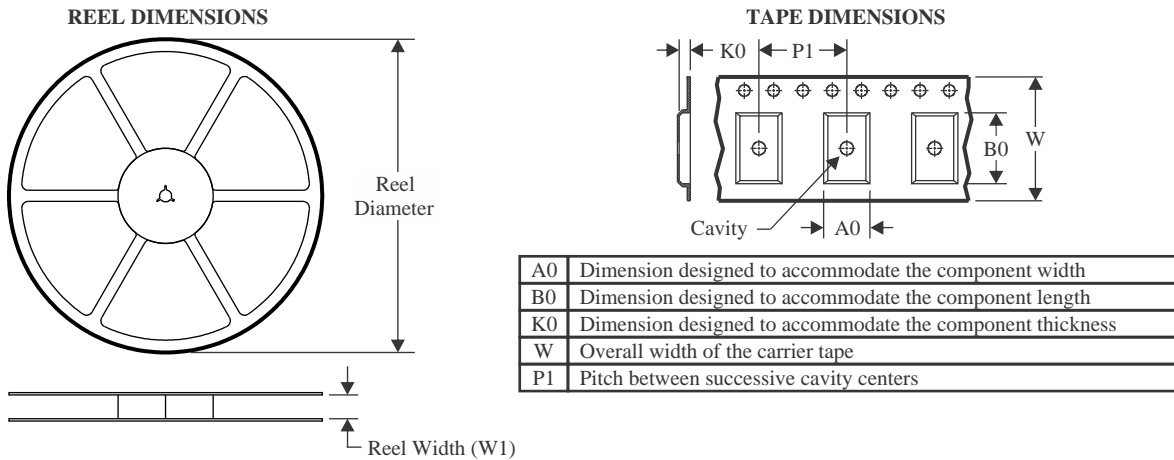
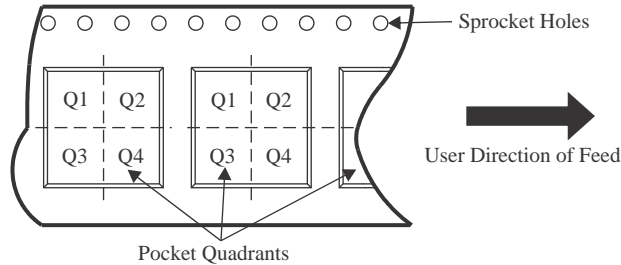
TAPE AND REEL INFORMATION

QUADRANT ASSIGNMENTS FOR PIN 1 ORIENTATION IN TAPE

*All dimensions are nominal

Device	Package Type	Package Drawing	Pins	SPQ	Reel Diameter (mm)	Reel Width W1 (mm)	A0 (mm)	B0 (mm)	K0 (mm)	P1 (mm)	W (mm)	Pin1 Quadrant
LP876411B4RQKRQ1	VQFN-HR	RQK	32	3000	330.0	12.4	5.25	5.75	1.05	8.0	12.0	Q1
LP876411B5RQKRQ1	VQFN-HR	RQK	32	3000	330.0	12.4	5.25	5.75	1.05	8.0	12.0	Q1
LP876429CFRQKRQ1	VQFN-HR	RQK	32	3000	330.0	12.4	5.25	5.75	1.05	8.0	12.0	Q1
LP876440C0RQKRQ1	VQFN-HR	RQK	32	3000	330.0	12.4	5.25	5.75	1.05	8.0	12.0	Q1
LP876441B1RQKRQ1	VQFN-HR	RQK	32	3000	330.0	12.4	5.25	5.75	1.05	8.0	12.0	Q1
LP876449CERQKRQ1	VQFN-HR	RQK	32	3000	330.0	12.4	5.25	5.75	1.05	8.0	12.0	Q1
LP876459CDRQKRQ1	VQFN-HR	RQK	32	3000	330.0	12.4	5.25	5.75	1.05	8.0	12.0	Q1

TAPE AND REEL BOX DIMENSIONS

*All dimensions are nominal

Device	Package Type	Package Drawing	Pins	SPQ	Length (mm)	Width (mm)	Height (mm)
LP876411B4RQKRQ1	VQFN-HR	RQK	32	3000	367.0	367.0	38.0
LP876411B5RQKRQ1	VQFN-HR	RQK	32	3000	367.0	367.0	38.0
LP876429CFRQKRQ1	VQFN-HR	RQK	32	3000	367.0	367.0	38.0
LP876440C0RQKRQ1	VQFN-HR	RQK	32	3000	367.0	367.0	38.0
LP876441B1RQKRQ1	VQFN-HR	RQK	32	3000	367.0	367.0	38.0
LP876449CERQKRQ1	VQFN-HR	RQK	32	3000	367.0	367.0	38.0
LP876459CDRQKRQ1	VQFN-HR	RQK	32	3000	367.0	367.0	38.0

GENERIC PACKAGE VIEW

RQK 32

VQFN-HR - 1 mm max height

5 x 5.5, 0.5 mm pitch

PLASTIC QUAD FLATPACK - NO LEAD

This image is a representation of the package family, actual package may vary.
Refer to the product data sheet for package details.

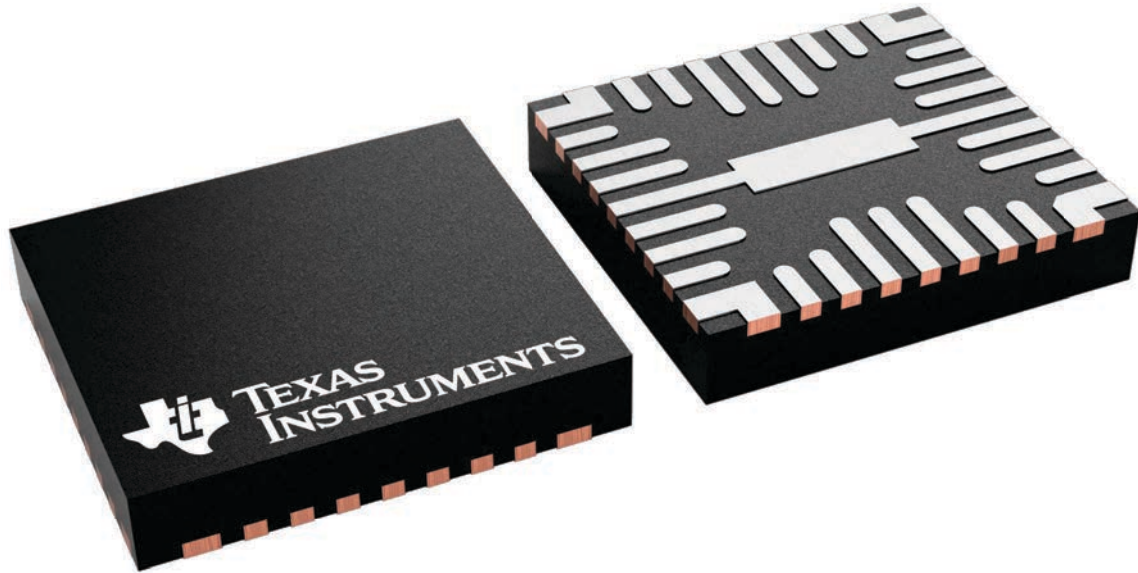

4225349/B

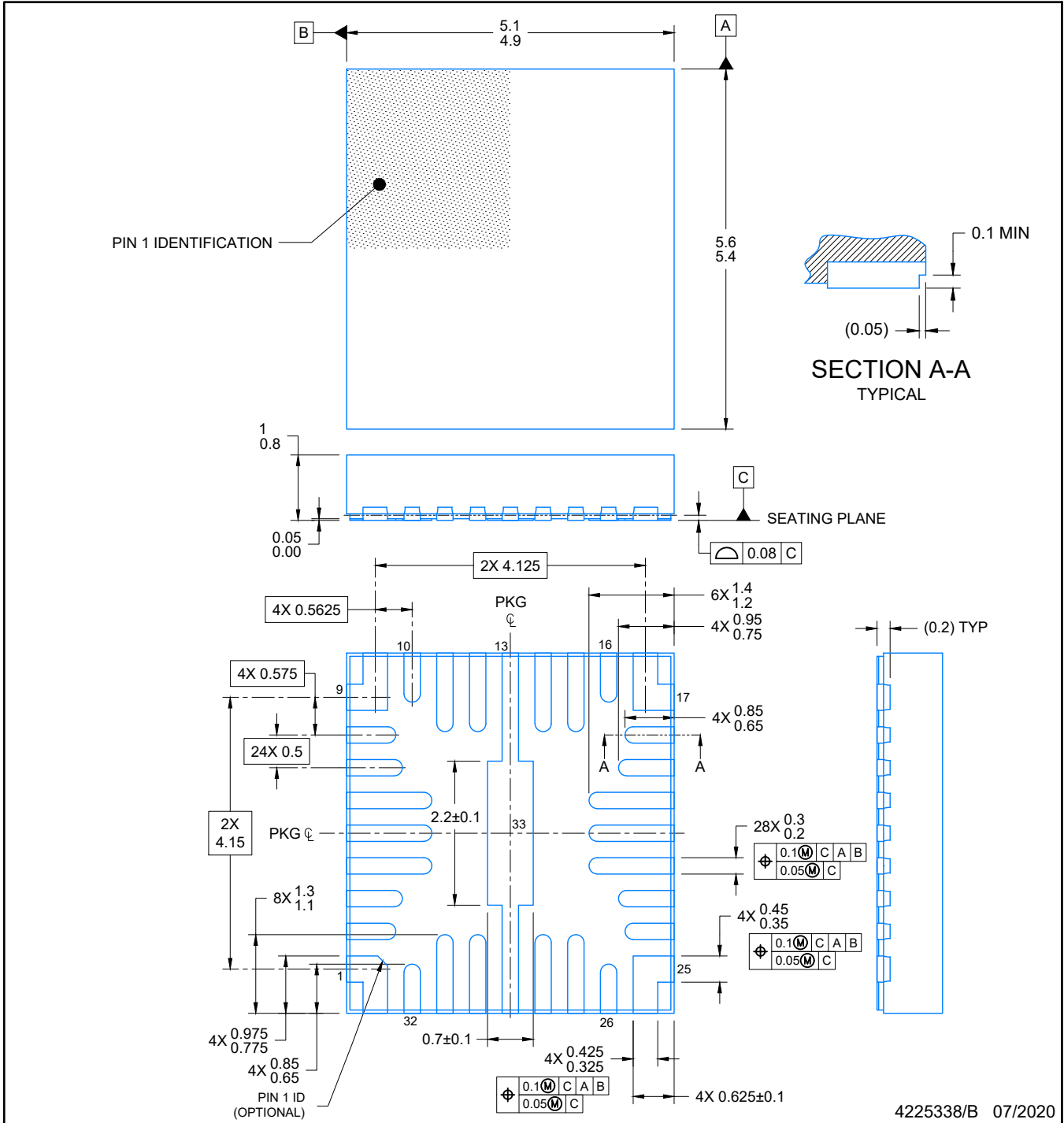

NOTES:

1. All linear dimensions are in millimeters. Any dimensions in parenthesis are for reference only. Dimensioning and tolerancing per ASME Y14.5M.
2. This drawing is subject to change without notice.

EXAMPLE STENCIL DESIGN

RQK0032A

VQFN-HR - 1 mm max height

PLASTIC QUAD FLATPACK-NO LEAD

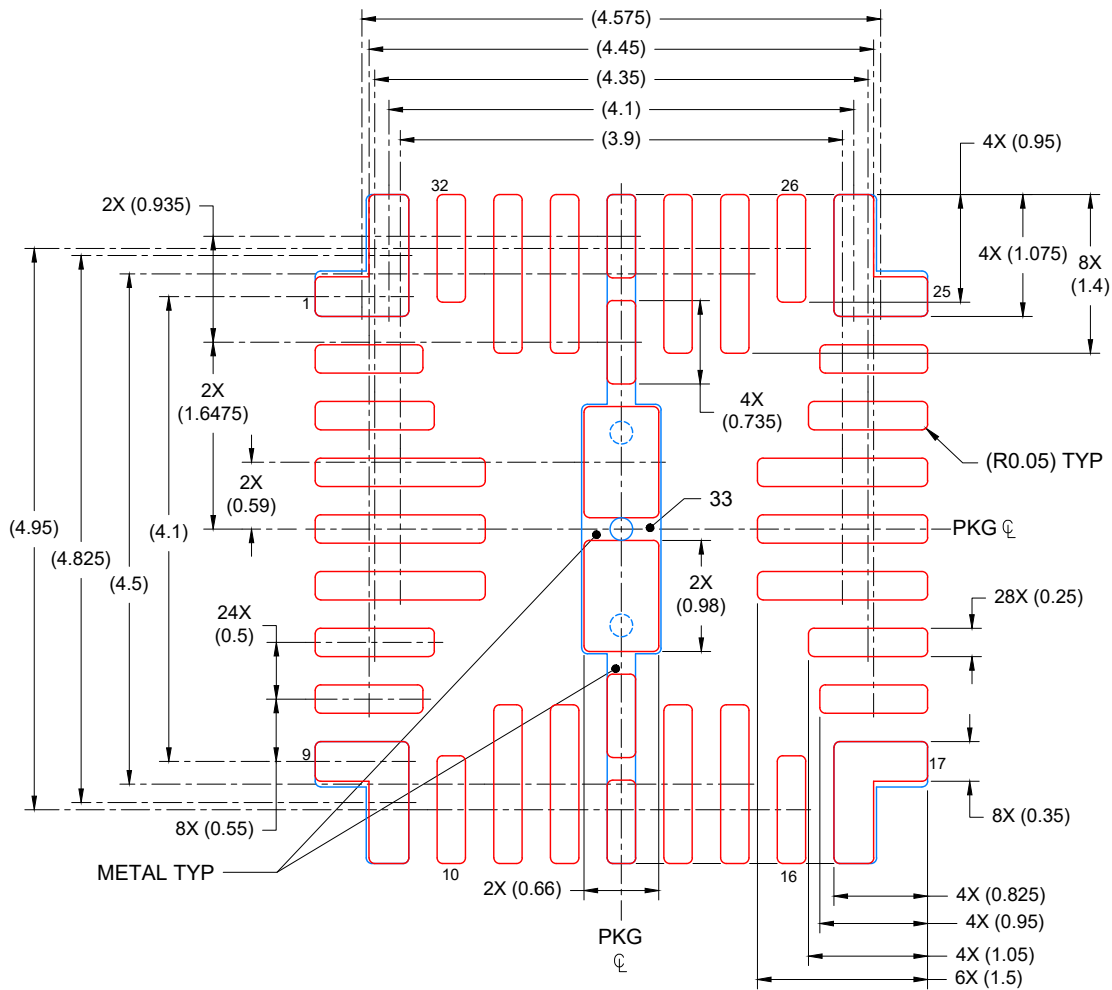

SOLDER PASTE EXAMPLE
BASED ON 0.1mm THICK STENCIL

PIN 1,9,16 & 25: 93%; PIN 13& 29: 79%; PIN 33: 84%
SCALE: 15X

4225338/B 07/2020

NOTES: (continued)

5. Laser cutting apertures with trapezoidal walls and rounded corners may offer better paste release. IPC-7525 may have alternate design recommendations.

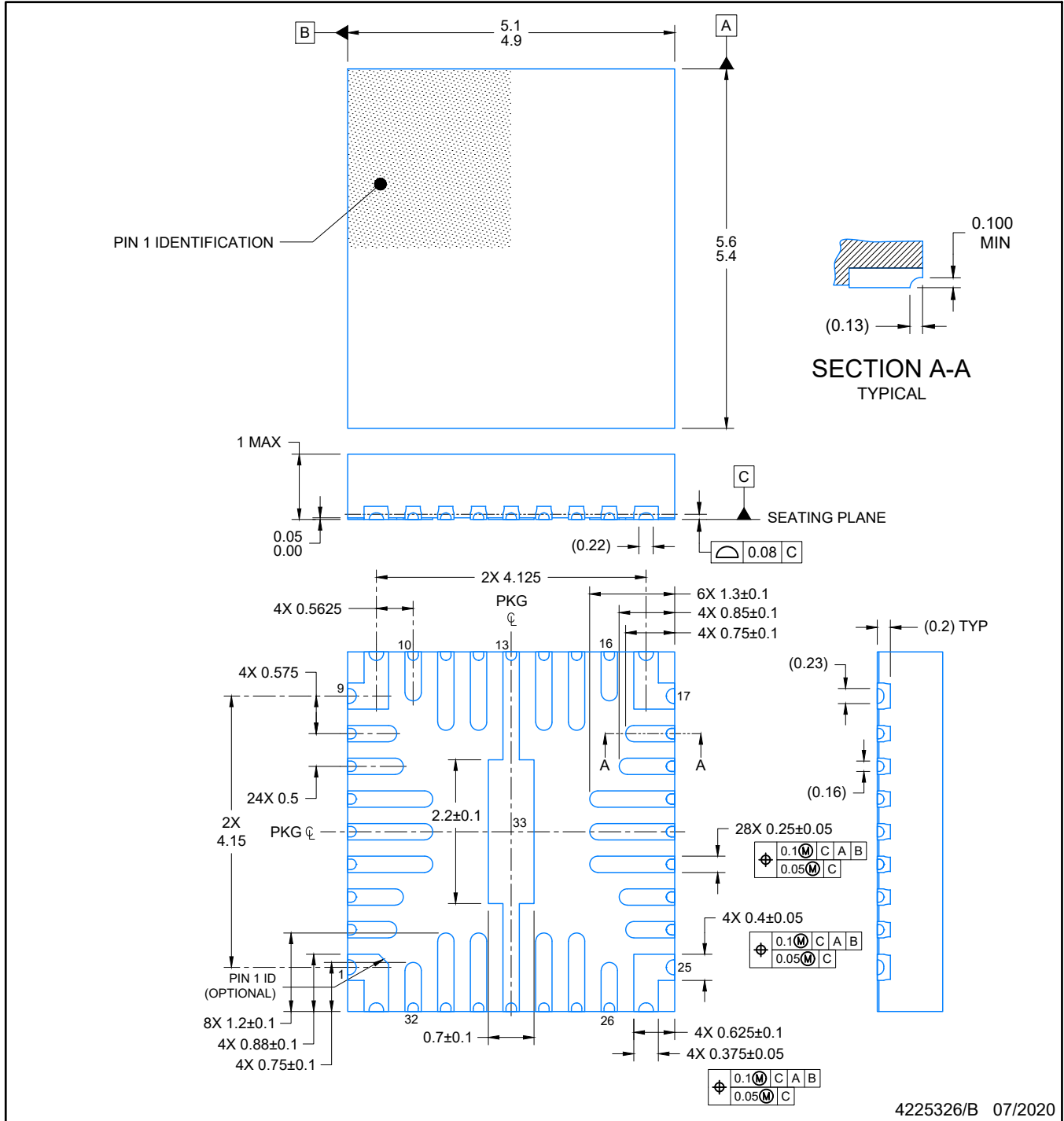

NOTES:

1. All linear dimensions are in millimeters. Any dimensions in parenthesis are for reference only. Dimensioning and tolerancing per ASME Y14.5M.
2. This drawing is subject to change without notice.

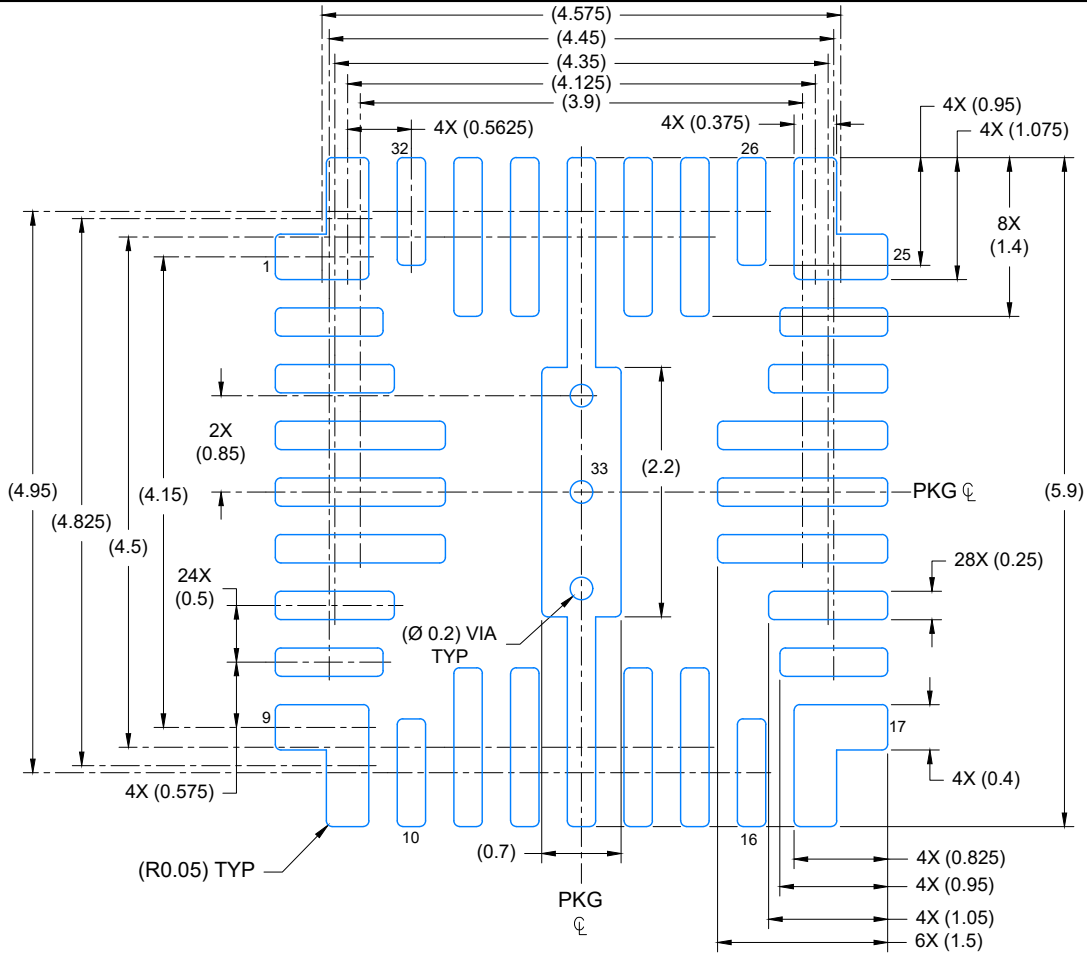

LAND PATTERN EXAMPLE
EXPOSED METAL SHOWN
SCALE: 15X

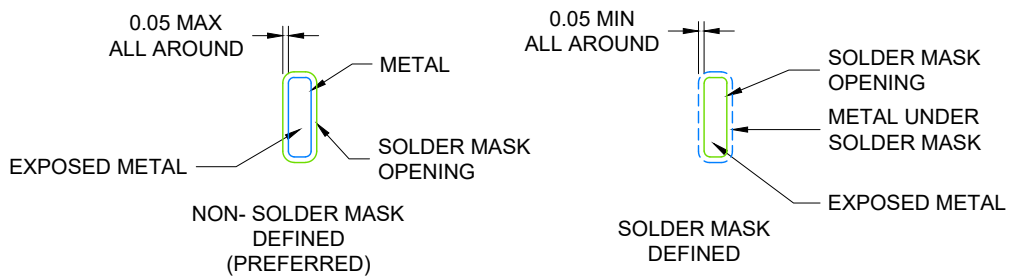

SOLDER MASK DETAILS
NOT TO SCALE

4225326/B 07/2020

NOTES: (continued)

3. For more information, see Texas Instruments literature number SLUA271 (www.ti.com/lit/sluea271).
4. Solder mask tolerances between and around signal pads can vary based on board fabrication site.

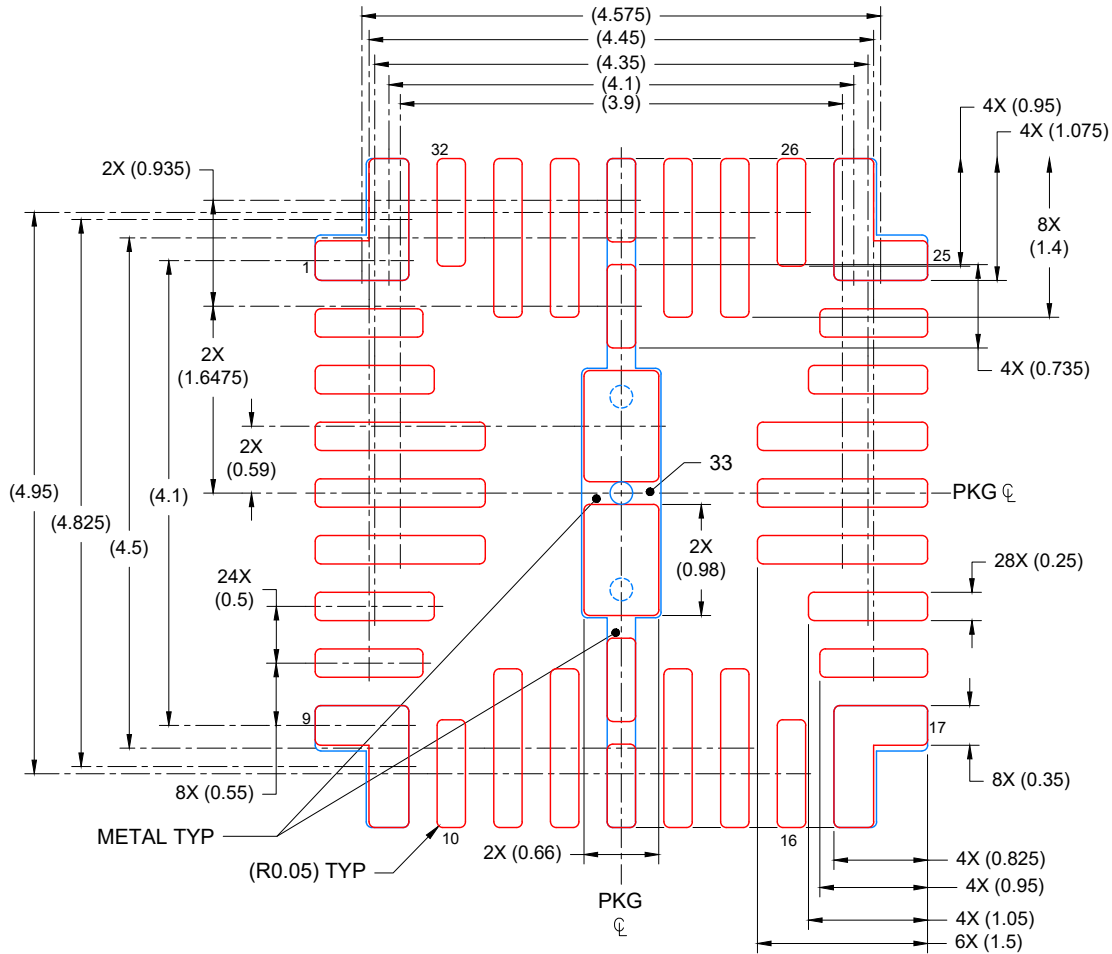

SOLDER PASTE EXAMPLE
 BASED ON 0.1mm THICK STENCIL

PIN 1,9,16 & 25: 93%; PIN 13& 29: 79%; PIN 33: 84%
 SCALE: 15X

4225326/B 07/2020

NOTES: (continued)

5. Laser cutting apertures with trapezoidal walls and rounded corners may offer better paste release. IPC-7525 may have alternate design recommendations.

IMPORTANT NOTICE AND DISCLAIMER

TI PROVIDES TECHNICAL AND RELIABILITY DATA (INCLUDING DATASHEETS), DESIGN RESOURCES (INCLUDING REFERENCE DESIGNS), APPLICATION OR OTHER DESIGN ADVICE, WEB TOOLS, SAFETY INFORMATION, AND OTHER RESOURCES "AS IS" AND WITH ALL FAULTS, AND DISCLAIMS ALL WARRANTIES, EXPRESS AND IMPLIED, INCLUDING WITHOUT LIMITATION ANY IMPLIED WARRANTIES OF MERCHANTABILITY, FITNESS FOR A PARTICULAR PURPOSE OR NON-INFRINGEMENT OF THIRD PARTY INTELLECTUAL PROPERTY RIGHTS.

These resources are intended for skilled developers designing with TI products. You are solely responsible for (1) selecting the appropriate TI products for your application, (2) designing, validating and testing your application, and (3) ensuring your application meets applicable standards, and any other safety, security, regulatory or other requirements.

These resources are subject to change without notice. TI grants you permission to use these resources only for development of an application that uses the TI products described in the resource. Other reproduction and display of these resources is prohibited. No license is granted to any other TI intellectual property right or to any third party intellectual property right. TI disclaims responsibility for, and you fully indemnify TI and its representatives against any claims, damages, costs, losses, and liabilities arising out of your use of these resources.

TI's products are provided subject to [TI's Terms of Sale](#), [TI's General Quality Guidelines](#), or other applicable terms available either on ti.com or provided in conjunction with such TI products. TI's provision of these resources does not expand or otherwise alter TI's applicable warranties or warranty disclaimers for TI products. Unless TI explicitly designates a product as custom or customer-specified, TI products are standard, catalog, general purpose devices.

TI objects to and rejects any additional or different terms you may propose.

Copyright © 2026, Texas Instruments Incorporated

Last updated 10/2025