

2.4 GHz IEEE 802.15.4 / ZigBee-ready RF Transceiver

Applications

- 2.4 GHz IEEE 802.15.4 systems
- ZigBee systems
- Home/building automation
- Industrial Control
- Wireless sensor networks
- PC peripherals
- Consumer Electronics

Product Description

The **CC2420** is a true single-chip 2.4 GHz IEEE 802.15.4 compliant RF transceiver designed for low power and low voltage wireless applications. **CC2420** includes a digital direct sequence spread spectrum baseband modem providing a spreading gain of 9 dB and an effective data rate of 250 kbps.

The **CC2420** is a low-cost, highly integrated solution for robust wireless communication in the 2.4 GHz unlicensed ISM band. It complies with worldwide regulations covered by ETSI EN 300 328 and EN 300 440 class 2 (Europe), FCC CFR47 Part 15 (US) and ARIB STD-T66 (Japan).

The **CC2420** provides extensive hardware support for packet handling, data buffering, burst transmissions, data encryption, data authentication, clear channel assessment, link quality indication and packet timing information. These

features reduce the load on the host controller and allow **CC2420** to interface low-cost microcontrollers.

The configuration interface and transmit / receive FIFOs of **CC2420** are accessed via an SPI interface. In a typical application **CC2420** will be used together with a microcontroller and a few external passive components.

CC2420 is based on Chipcon's SmartRF®-03 technology in 0.18 μm CMOS.



Key Features

- True single-chip 2.4 GHz IEEE 802.15.4 compliant RF transceiver with baseband modem and MAC support
- DSSS baseband modem with 2 MChips/s and 250 kbps effective data rate.
- Suitable for both RFD and FFD operation
- Low current consumption (RX: 18.8 mA, TX: 17.4 mA)
- Low supply voltage (2.1 – 3.6 V) with integrated voltage regulator
- Low supply voltage (1.6 – 2.0 V) with external voltage regulator
- Programmable output power
- No external RF switch / filter needed
- I/Q low-IF receiver
- I/Q direct upconversion transmitter
- Very few external components
- 128(RX) + 128(TX) byte data buffering
- Digital RSSI / LQI support
- Hardware MAC encryption (AES-128)
- Battery monitor
- QLP-48 package, 7x7 mm
- Complies with ETSI EN 300 328, EN 300 440 class 2, FCC CFR-47 part 15 and ARIB STD-T66
- Powerful and flexible development tools available

Table of contents

1	Abbreviations	5
2	References	6
3	Features	7
4	Absolute Maximum Ratings	8
5	Operating Conditions	8
6	Electrical Specifications	9
6.1	Overall	9
6.2	Transmit Section	9
6.3	Receive Section	10
6.4	RSSI / Carrier Sense	11
6.5	IF Section	11
6.6	Frequency Synthesizer Section	11
6.7	Digital Inputs/Outputs	12
6.8	Voltage Regulator	13
6.9	Battery Monitor	13
6.10	Power Supply	13
7	Pin Assignment	15
8	Circuit Description	17
9	Application Circuit	19
9.1	Input / output matching	19
9.2	Bias resistor	19
9.3	Crystal	19
9.4	Voltage regulator	19
9.5	Power supply decoupling and filtering	19
10	IEEE 802.15.4 Modulation Format	24
11	Configuration Overview	25
12	Evaluation Software	26
13	4-wire Serial Configuration and Data Interface	27
13.1	Pin configuration	27
13.2	Register access	27
13.3	Status byte	28
13.4	Command strobes	29
13.5	RAM access	29
13.6	FIFO access	31
13.7	Multiple SPI access	31
14	Microcontroller Interface and Pin Description	32
14.1	Configuration interface	32
14.2	Receive mode	33
14.3	RXFIFO overflow	33
14.4	Transmit mode	34
14.5	General control and status pins	35
15	Demodulator, Symbol Synchroniser and Data Decision	35
16	Frame Format	36
16.1	Synchronisation header	36
16.2	Length field	37
16.3	MAC protocol data unit	37
16.4	Frame check sequence	38

17	RF Data Buffering	39
17.1	Buffered transmit mode	39
17.2	Buffered receive mode	39
17.3	Unbuffered, serial mode	40
18	Address Recognition	41
19	Acknowledge Frames	41
20	Radio control state machine	43
21	MAC Security Operations (Encryption and Authentication)	45
21.1	Keys	45
21.2	Nonce / counter	45
21.3	Stand-alone encryption	46
21.4	In-line security operations	46
21.5	CTR mode encryption / decryption	47
21.6	CBC-MAC	47
21.7	CCM	47
21.8	Timing	48
22	Linear IF and AGC Settings	48
23	RSSI / Energy Detection	48
24	Link Quality Indication	49
25	Clear Channel Assessment	50
26	Frequency and Channel Programming	50
27	VCO and PLL Self-Calibration	51
27.1	VCO	51
27.2	PLL self-calibration	51
28	Output Power Programming	51
29	Voltage Regulator	51
30	Battery Monitor	52
31	Crystal Oscillator	53
32	Input / Output Matching	54
33	Transmitter Test Modes	55
33.1	Unmodulated carrier	55
33.2	Modulated spectrum	56
34	System Considerations and Guidelines	57
34.1	Frequency hopping and multi-channel systems	57
34.2	Data burst transmissions	57
34.3	Crystal accuracy and drift	57
34.4	Communication robustness	57
34.5	Communication security	57
34.6	Low-cost systems	58
34.7	Battery operated systems	58
34.8	BER / PER measurements	58
35	PCB Layout Recommendations	59
36	Antenna Considerations	59
37	Configuration Registers	61
38	Test Output Signals	81
39	Package Description (QLP 48)	Error! Bookmark not defined.
40	Recommended layout for package (QLP 48)	Error! Bookmark not defined.

40.1	Package thermal properties _____	Error! Bookmark not defined.
40.2	Soldering information _____	83
40.3	Plastic tube specification _____	Error! Bookmark not defined.
40.4	Carrier tape and reel specification _____	Error! Bookmark not defined.
41	Ordering Information _____	Error! Bookmark not defined.
42	General Information _____	84
42.1	Document History _____	84
42.2	Product Status Definitions _____	Error! Bookmark not defined.
43	Address Information _____	Error! Bookmark not defined.
44	TI Worldwide Technical Support _____	Error! Bookmark not defined.
	Important Notice _____	Error! Bookmark not defined.

1 Abbreviations

ADC	-	Analog to Digital Converter
AES	-	Advanced Encryption Standard
AGC	-	Automatic Gain Control
ARIB	-	Association of Radio Industries and Businesses
BER	-	Bit Error Rate
CBC-MAC	-	Cipher Block Chaining Message Authentication Code
CCA	-	Clear Channel Assessment
CCM	-	Counter mode + CBC-MAC
CFR	-	Code of Federal Regulations
CSMA-CA	-	Carrier Sense Multiple Access with Collision Avoidance
CTR	-	Counter mode (encryption)
CW	-	Continuous Wave
DAC	-	Digital to Analog Converter
DSSS	-	Direct Sequence Spread Spectrum
ESD	-	Electro Static Discharge
ESR	-	Equivalent Series Resistance
EVM	-	Error Vector Magnitude
FCC	-	Federal Communications Commission
FCF	-	Frame Control Field
FIFO	-	First In First Out
FFCTRL	-	FIFO and Frame Control
HSSD	-	High Speed Serial Debug
IEEE	-	Institute of Electrical and Electronics Engineers
IF	-	Intermediate Frequency
ISM	-	Industrial, Scientific and Medical
ITU-T	-	International Telecommunication Union – Telecommunication Standardization Sector
I/O	-	Input / Output
I/Q	-	In-phase / Quadrature-phase
kbps	-	kilo bits per second
LNA	-	Low-Noise Amplifier
LO	-	Local Oscillator
LQI	-	Link Quality Indication
LSB	-	Least Significant Bit / Byte
MAC	-	Medium Access Control
MFR	-	MAC Footer
MHR	-	MAC Header
MIC	-	Message Integrity Code
MPDU	-	MAC Protocol Data Unit
MSDU	-	MAC Service Data Unit
NA	-	Not Available
NC	-	Not Connected
O-QPSK	-	Offset - Quadrature Phase Shift Keying
PA	-	Power Amplifier
PCB	-	Printed Circuit Board
PER	-	Packet Error Rate
PHY	-	Physical Layer
PHR	-	PHY Header
PLL	-	Phase Locked Loop
PSDU	-	PHY Service Data Unit
QLP	-	Quad Leadless Package
RAM	-	Random Access Memory
RBW	-	Resolution BandWidth
RF	-	Radio Frequency
RSSI	-	Receive Signal Strength Indicator

RX	-	Receive
SHR	-	Synchronisation Header
SPI	-	Serial Peripheral Interface
TBD	-	To Be Decided / To Be Defined
T/R	-	Transmit / Receive
TX	-	Transmit
VCO	-	Voltage Controlled Oscillator
VGA	-	Variable Gain Amplifier

2 References

- [1] IEEE std. 802.15.4 - 2003: Wireless Medium Access Control (MAC) and Physical Layer (PHY) specifications for Low Rate Wireless Personal Area Networks (LR-WPANs)
- <http://standards.ieee.org/getieee802/download/802.15.4-2003.pdf>
- [2] NIST FIPS Pub 197: Advanced Encryption Standard (AES), Federal Information Processing Standards Publication 197, US Department of Commerce/N.I.S.T., November 26, 2001. Available from the NIST website.
- <http://csrc.nist.gov/publications/fips/fips197/fips-197.pdf>
- [3] R. Housley, D. Whiting, N. Ferguson, Counter with CBC-MAC (CCM), submitted to NIST, June 3, 2002. Available from the NIST website.
- <http://csrc.nist.gov/CryptoToolkit/modes/proposedmodes/ProposedModesPage.html>

3 Features

- 2400 – 2483.5 MHz RF Transceiver
 - Direct Sequence Spread Spectrum (DSSS) transceiver
 - 250 kbps data rate, 2 MChip/s chip rate
 - O-QPSK with half sine pulse shaping modulation
 - Very low current consumption (RX: 18.8 mA, TX: 17.4 mA)
 - High sensitivity (-95 dBm)
 - High adjacent channel rejection (30/45 dB)
 - High alternate channel rejection (53/54 dB)
 - On-chip VCO, LNA and PA
 - Low supply voltage (2.1 – 3.6 V) with on-chip voltage regulator
 - Programmable output power
 - I/Q low-IF soft decision receiver
 - I/Q direct up-conversion transmitter

- Separate transmit and receive FIFOs
 - 128 byte transmit data FIFO
 - 128 byte receive data FIFO

- Very few external components
 - Only reference crystal and a minimised number of passives
 - No external filters needed

- Easy configuration interface
 - 4-wire SPI interface
 - Serial clock up to 10 MHz

- 802.15.4 MAC hardware support:
 - Automatic preamble generator
 - Synchronisation word insertion/detection
 - CRC-16 computation and checking over the MAC payload
 - Clear Channel Assessment
 - Energy detection / digital RSSI
 - Link Quality Indication
 - Full automatic MAC security (CTR, CBC-MAC, CCM)

- 802.15.4 MAC hardware security:
 - Automated security operations within the receive and transmit FIFOs.
 - CTR mode encryption / decryption
 - CBC-MAC authentication
 - CCM encryption / decryption and authentication
 - Stand-alone AES encryption

- Development tools available
 - Fully equipped development kit
 - Demonstration board reference design with microcontroller code
 - Easy-to-use software for generating the **CC2420** configuration data

- Small size QLP-48 package, 7 x 7 mm
- Complies with EN 300 328, EN 300 440 class 2, FCC CFR47 part 15 and ARIB STD-T66

4 Absolute Maximum Ratings

Parameter	Min.	Max.	Units	Condition
Supply voltage for on-chip voltage regulator, VREG_IN pin 43.	-0.3	3.6	V	
Supply voltage (VDDIO) for digital I/Os, DVDD3.3, pin 25.	-0.3	3.6	V	
Supply voltage (VDD) on AVDD_VCO, DVDD1.8, etc (pin no 1, 2, 3, 4, 10, 14, 15, 17, 18, 20, 26, 35, 37, 44 and 48)	-0.3	2.0	V	
Voltage on any digital I/O pin, (pin no. 21, 27-34 and 41)	-0.3	VDDIO+0.3, max 3.6	V	
Voltage on any other pin, (pin no. 6, 7, 8, 11, 12, 13, 16, 36, 38, 39, 40, 45, 46 and 47)	-0.3	VDD+0.3, max 2.0	V	
Input RF level		10	dBm	
Storage temperature range	-50	150	°C	
Reflow solder temperature		260	°C	T = 10 s

The absolute maximum ratings given above should under no circumstances be violated. Stress exceeding one or more of

the limiting values may cause permanent damage to the device.

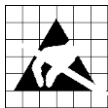

Caution! ESD sensitive device. Precaution should be used when handling the device in order to prevent permanent damage.

5 Operating Conditions

Parameter	Min.	Typ.	Max.	Units	Condition
Supply voltage for on-chip voltage regulator, VREG_IN pin 43.	2.1		3.6	V	
Supply voltage (VDDIO) for digital I/Os, DVDD3.3, pin 25.	1.6		3.6	V	The digital I/O voltage (DVDD3.3 pin) must match the external interfacing circuit (e.g. microcontroller).
Supply voltage (VDD) on AVDD_VCO, DVDD1.8, etc (pin no 1, 2, 3, 4, 10, 14, 15, 17, 18, 20, 26, 35, 37, 44 and 48)	1.6	1.8	2.0	V	The typical application uses regulated 1.8 V supply generated by the on-chip voltage regulator.
Operating ambient temperature range, T _A	-40		85	°C	

6 Electrical Specifications

Measured on **CC2420** EM with transmission line balun, $T_A = 25\text{ }^\circ\text{C}$, DVDD3.3 and VREG_IN = 3.3 V, internal voltage regulator used if nothing else stated.

6.1 Overall

Parameter	Min.	Typ.	Max.	Unit	Condition / Note
RF Frequency Range	2400		2483.5	MHz	Programmable in 1 MHz steps, 5 MHz steps for compliance with [1]

6.2 Transmit Section

Parameter	Min.	Typ.	Max.	Unit	Condition / Note
Transmit bit rate	250		250	kbps	As defined by [1]
Transmit chip rate	2000		2000	kChips/s	As defined by [1]
Nominal output power	-3	0		dBm	Delivered to a single ended 50 Ω load through a balun. [1] requires minimum -3 dBm
Programmable output power range		24		dB	The output power is programmable in 8 steps from approximately -24 to 0 dBm.
Harmonics 2 nd harmonic 3 rd harmonic		-44 -64		dBm dBm	Measured conducted with 1 MHz resolution bandwidth on spectrum analyser. At max output power delivered to a single ended 50 Ω load through a balun. See page 54.
Spurious emission 30 - 1000 MHz 1- 12.75 GHz 1.8 - 1.9 GHz 5.15 - 5.3 GHz		-56 -44 -56 -51		dBm dBm dBm dBm	Maximum output power. Complies with EN 300 328, EN 300 440, FCC CFR47 Part 15 and ARIB STD-T-66
Error Vector Magnitude (EVM)		11		%	Measured as defined by [1] [1] requires max. 35 %
Optimum load impedance		95 + j187		Ω	Differential impedance as seen from the RF-port (RF_P and RF_N) towards the antenna. For matching details see the Input / Output Matching section on page 54.

6.3 Receive Section

Parameter	Min.	Typ.	Max.	Unit	Condition / Note
Receiver Sensitivity	-90	-95		dBm	PER = 1%, as specified by [1] Measured in a 50Ω single-ended load through a balun. [1] requires -85 dBm
Saturation (maximum input level)	0	10		dBm	PER = 1%, as specified by [1] Measured in a 50Ω single-ended load through a balun. [1] requires -20 dBm
Adjacent channel rejection + 5 MHz channel spacing		45		dB	Wanted signal @ -82 dBm, adjacent modulated channel at +5 MHz, PER = 1 %, as specified by [1]. [1] requires 0 dB
Adjacent channel rejection - 5 MHz channel spacing		30		dB	Wanted signal @ -82 dBm, adjacent modulated channel at -5 MHz, PER = 1 %, as specified by [1]. [1] requires 0 dB
Alternate channel rejection + 10 MHz channel spacing		54		dB	Wanted signal @ -82 dBm, adjacent modulated channel at +10 MHz, PER = 1 %, as specified by [1] [1] requires 30 dB
Alternate channel rejection - 10 MHz channel spacing		53		dB	Wanted signal @ -82 dBm, adjacent modulated channel at -10 MHz, PER = 1 %, as specified by [1] [1] requires 30 dB
Channel rejection ≥ + 15 MHz		62		dB	Wanted signal @ -82 dBm. Undesired signal is an IEEE 802.15.4 modulated channel, stepped through all channels from 2405 to 2480 MHz. Signal level for PER = 1%.
≤ - 15 MHz		62		dB	
Co-channel rejection		-3		dB	Wanted signal @ -82 dBm. Undesired signal is an IEEE 802.15.4 modulated at the same frequency as the desired signal. Signal level for PER = 1%.
Blocking / Desensitisation +/- 5 MHz from band edge		-28		dBm	Wanted signal 3 dB above the sensitivity level, CW jammer, PER = 1%. Complies with EN 300 440 class 2.
+/- 20 MHz from band edge		-28		dBm	
+/- 30 MHz from band edge		-27		dBm	
+/- 50 MHz from band edge		-28		dBm	
Spurious emission 30 – 1000 MHz		-73		dBm	Conducted measurement in a 50 Ω single ended load. Measured according to EN 300 328, EN 300 440 class 2, FCC CFR47, Part 15 and ARIB STD-T-66
1 – 12.75 GHz		-58		dBm	

Parameter	Min.	Typ.	Max.	Unit	Condition / Note
Frequency error tolerance	-300		300	kHz	Difference between centre frequency of the received RF signal and local oscillator frequency [1] requires 200 kHz
Symbol rate error tolerance			120	ppm	Difference between incoming symbol rate and the internally generated symbol rate [1] requires 80 ppm
Data latency		3		μs	Processing delay in receiver. Time from complete transmission of SFD until complete reception of SFD, i.e. from SFD goes active on transmitter until active on receiver.

6.4 RSSI / Carrier Sense

Parameter	Min.	Typ.	Max.	Unit	Condition / Note
Carrier sense level		- 77		dBm	Programmable in <code>RSSI.CCA_THR</code>
RSSI dynamic range		100		dB	The range is approximately from -100 dBm to 0 dBm
RSSI accuracy		± 6		dB	See page 48 for details
RSSI linearity		± 3		dB	
RSSI average time		128		μs	8 symbol periods, as specified by [1]

6.5 IF Section

Parameter	Min.	Typ.	Max.	Unit	Condition / Note
Intermediate frequency (IF)		2		MHz	

6.6 Frequency Synthesizer Section

Parameter	Min.	Typ.	Max.	Unit	Condition / Note
Crystal oscillator frequency		16		MHz	See page 53 for details.
Crystal frequency accuracy requirement	- 40		40	ppm	Including aging and temperature dependency, as specified by [1]
Crystal operation		Parallel			C381 and C391 are loading capacitors, see page 53

Parameter	Min.	Typ.	Max.	Unit	Condition / Note
Crystal load capacitance	12	16	20	pF	16 pF recommended
Crystal ESR			60	Ω	
Crystal oscillator start-up time		1.0		ms	16 pF load
Phase noise		-109 -117 -117 -117		dBc/Hz dBc/Hz dBc/Hz dBc/Hz	Unmodulated carrier At ± 1 MHz offset from carrier At ± 2 MHz offset from carrier At ± 3 MHz offset from carrier At ± 5 MHz offset from carrier
PLL loop bandwidth		100		kHz	
PLL lock time			192	μ s	The startup time from the crystal oscillator is running and RX / TX turnaround time

6.7 Digital Inputs/Outputs

Parameter	Min.	Typ.	Max.	Unit	Condition / Note
General					Signal levels are referred to the voltage level at pin DVDD3 . 3
Logic "0" input voltage	0		0.3* DVDD	V	
Logic "1" input voltage	0.7* DVDD		DVDD	V	
Logic "0" output voltage	0		0.4	V	Output current -8 mA, 3.3 V supply voltage
Logic "1" output voltage	2.5		VDD	V	Output current 8 mA, 3.3 V supply voltage
Logic "0" input current	NA		-1	μ A	Input signal equals GND
Logic "1" input current	NA		1	μ A	Input signal equals VDD
FIFO setup time	20			ns	TX unbuffered mode, minimum time FIFO must be ready before the positive edge of FIFOP
FIFO hold time	10			ns	TX unbuffered mode, minimum time FIFO must be held after the positive edge of FIFOP
Serial interface pins (SCLK, SI, SO and CSn) timing specification					See Table 4 on page 28

6.8 Voltage Regulator

Parameter	Min.	Typ.	Max.	Unit	Condition / Note
General					Note that the internal voltage regulator can only supply CC2420 and no external circuitry.
Input Voltage	2.1	3.0	3.6	V	On the VREG_IN pin
Output Voltage	1.7	1.8	1.9	V	On the VREG_OUT pin
Quiescent current	13	20	29	μA	No current drawn from the VREG_OUT pin. Min and max numbers include 2.1 through 3.6 V input voltage
Start-up time		0.3	0.6	ms	

6.9 Battery Monitor

Parameter	Min.	Typ.	Max.	Unit	Condition / Note
Current consumption	6	30	90	μA	When enabled
Start-up time			100	μs	Voltage regulator already enabled
Settling time			2	μs	New toggle voltage programmed
Step size			50	mV	
Hysteresis			10	mV	
Absolute accuracy	-80		80	mV	May be software calibrated for known reference voltage
Relative accuracy	-50		50	mV	

6.10 Power Supply

Parameter	Min.	Typ.	Max.	Unit	Condition / Note
Current consumption in different modes (see Figure 25, page 44)					Current drawn from VREG_IN, through voltage regulator
Voltage regulator off (OFF)		0.02	1	μA	Voltage regulator off
Power Down mode (PD)		20		μA	Voltage regulator on
Idle mode (IDLE)		426		μA	Including crystal oscillator and voltage regulator
Current Consumption, receive mode		18.8		mA	

Parameter	Min.	Typ.	Max.	Unit	Condition / Note
Current Consumption, transmit mode:					
P = -25 dBm		8.5		mA	The output power is delivered differentially to a 50 Ω singled ended load through a balun, see also page 54.
P = -15 dBm		9.9		mA	
P = -10 dBm		11		mA	
P = -5 dBm		14		mA	
P = 0 dBm		17.4		mA	

7 Pin Assignment

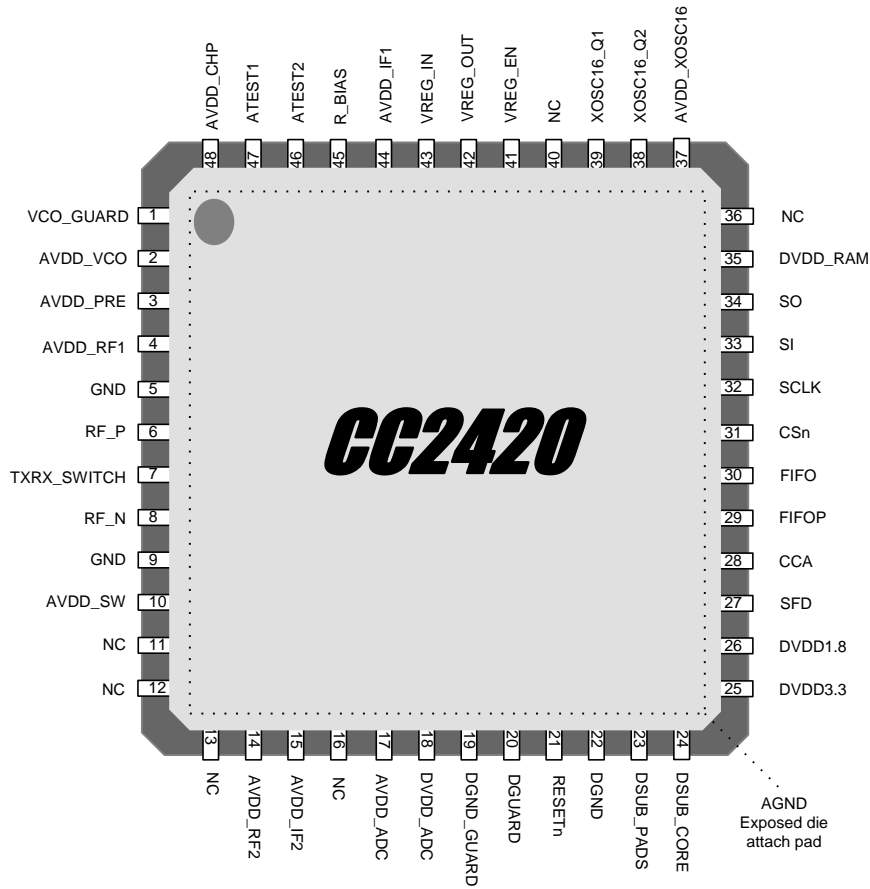

Figure 1. **CC2420** Pinout – Top View

Pin	Pin Name	Pin type	Pin Description
-	AGND	Ground (analog)	Exposed die attach pad. Must be connected to solid ground plane
1	VCO_GUARD	Power (analog)	Connection of guard ring for VCO (to AVDD) shielding
2	AVDD_VCO	Power (analog)	1.8 V Power supply for VCO
3	AVDD_PRE	Power (analog)	1.8 V Power supply for Prescaler
4	AVDD_RF1	Power (analog)	1.8 V Power supply for RF front-end
5	GND	Ground (analog)	Grounded pin for RF shielding
6	RF_P	RF I/O	Positive RF input/output signal to LNA/from PA in receive/transmit mode
7	TXRX_SWITCH	Power (analog)	Common supply connection for integrated RF front-end. Must be connected to RF_P and RF_N externally through a DC path
8	RF_N	RF I/O	Negative RF input/output signal to LNA/from PA in receive/transmit mode
9	GND	Ground (analog)	Grounded pin for RF shielding
10	AVDD_SW	Power (analog)	1.8 V Power supply for LNA / PA switch
11	NC	-	Not Connected
12	NC	-	Not Connected
13	NC	-	Not Connected
14	AVDD_RF2	Power (analog)	1.8 V Power supply for receive and transmit mixers

Pin	Pin Name	Pin type	Pin Description
15	AVDD_IF2	Power (analog)	1.8 V Power supply for transmit / receive IF chain
16	NC	-	Not Connected
17	AVDD_ADC	Power (analog)	1.8 V Power supply for analog parts of ADCs and DACs
18	DVDD_ADC	Power (digital)	1.8 V Power supply for digital parts of receive ADCs
19	DGND_GUARD	Ground (digital)	Ground connection for digital noise isolation
20	DGUARD	Power (digital)	1.8 V Power supply connection for digital noise isolation
21	RESETn	Digital Input	Asynchronous, active low digital reset
22	DGND	Ground (digital)	Ground connection for digital core and pads
23	DSUB_PADS	Ground (digital)	Substrate connection for digital pads
24	DSUB_CORE	Ground (digital)	Substrate connection for digital modules
25	DVDD3.3	Power (digital)	3.3 V Power supply for digital I/Os
26	DVDD1.8	Power (digital)	1.8 V Power supply for digital core
27	SFD	Digital output	SFD (Start of Frame Delimiter) / digital mux output
28	CCA	Digital output	CCA (Clear Channel Assessment) / digital mux output
29	FIFOP	Digital output	Active when number of bytes in FIFO exceeds threshold / serial RF clock output in test mode
30	FIFO	Digital I/O	Active when data in FIFO / serial RF data input / output in test mode
31	CSn	Digital input	SPI Chip select, active low
32	SCLK	Digital input	SPI Clock input, up to 10 MHz
33	SI	Digital input	SPI Slave Input. Sampled on the positive edge of SCLK
34	SO	Digital output (tristate)	SPI Slave Output. Updated on the negative edge of SCLK. Tristate when CSn high.
35	DVDD_RAM	Power (digital)	1.8 V Power supply for digital RAM
36	NC	-	Not Connected
37	AVDD_XOSC16	Power (analog)	1.8 V crystal oscillator power supply
38	XOSC16_Q2	Analog I/O	16 MHz Crystal oscillator pin 2
39	XOSC16_Q1	Analog I/O	16 MHz Crystal oscillator pin 1 or external clock input
40	NC	-	Not Connected
41	VREG_EN	Digital input	Voltage regulator enable, active high, held at VREG_IN voltage level when active. Note that VREG_EN is relative VREG_IN, not DVDD3.3.
42	VREG_OUT	Power output	Voltage regulator 1.8 V power supply output
43	VREG_IN	Power (analog)	Voltage regulator 2.1 to 3.6 V power supply input
44	AVDD_IF1	Power (analog)	1.8 V Power supply for transmit / receive IF chain
45	R_BIAS	Analog output	External precision resistor, 43 k Ω , \pm 1 %
46	ATEST2	Analog I/O	Analog test I/O for prototype and production testing
47	ATEST1	Analog I/O	Analog test I/O for prototype and production testing
48	AVDD_CHP	Power (analog)	1.8 V Power supply for phase detector and charge pump

NOTES:

The exposed die attach pad **must** be connected to a solid ground plane as this is the main ground connection for the chip.

8 Circuit Description

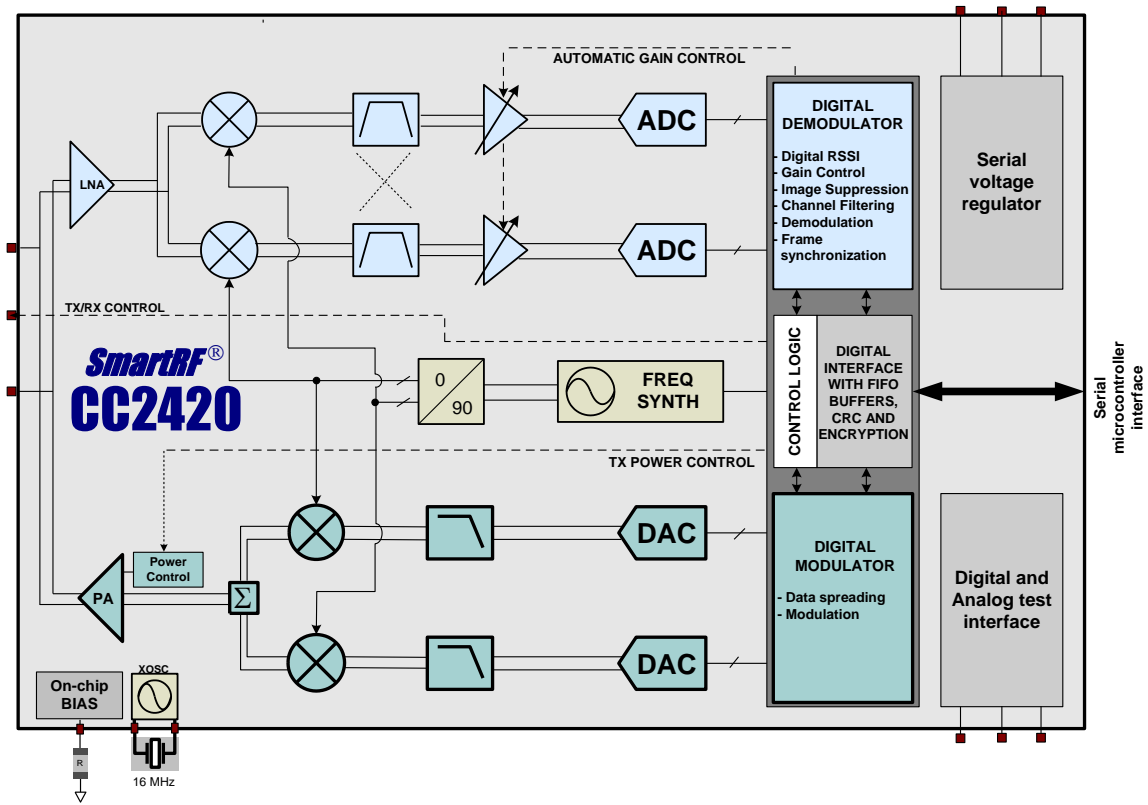

Figure 2. **CC2420** simplified block diagram

A simplified block diagram of **CC2420** is shown in Figure 2.

CC2420 features a low-IF receiver. The received RF signal is amplified by the low-noise amplifier (LNA) and down-converted in quadrature (I and Q) to the intermediate frequency (IF). At IF (2 MHz), the complex I/Q signal is filtered and amplified, and then digitized by the ADCs. Automatic gain control, final channel filtering, despreading, symbol correlation and byte synchronization are performed digitally.

When the `SFD` pin goes active, this indicates that a start of frame delimiter has been detected. **CC2420** buffers the received data in a 128 byte receive FIFO. The user may read the FIFO through an SPI interface. CRC is verified in hardware. RSSI and correlation values are appended to the frame. CCA is available on a pin in receive mode. Serial (unbuffered) data modes are also available for test purposes.

The **CC2420** transmitter is based on direct up-conversion. The data is buffered in a 128 byte transmit FIFO (separate from the receive FIFO). The preamble and start of frame delimiter are generated by hardware. Each symbol (4 bits) is spread using the IEEE 802.15.4 spreading sequence to 32 chips and output to the digital-to-analog converters (DACs).

An analog low pass filter passes the signal to the quadrature (I and Q) upconversion mixers. The RF signal is amplified in the power amplifier (PA) and fed to the antenna.

The internal T/R switch circuitry makes the antenna interface and matching easy. The RF connection is differential. A balun may be used for single-ended antennas. The biasing of the PA and LNA is done by connecting `TXRX_SWITCH` to `RF_P` and `RF_N` through an external DC path.

The frequency synthesizer includes a completely on-chip LC VCO and a 90

degrees phase splitter for generating the I and Q LO signals to the down-conversion mixers in receive mode and up-conversion mixers in transmit mode. The VCO operates in the frequency range 4800 – 4966 MHz, and the frequency is divided by two when split in I and Q.

A crystal must be connected to XOSC16_Q1 and XOSC16_Q2 and provides the reference frequency for the synthesizer. A digital lock signal is available from the PLL.

The digital baseband includes support for frame handling, address recognition, data buffering and MAC security.

The 4-wire SPI serial interface is used for configuration and data buffering.

An on-chip voltage regulator delivers the regulated 1.8 V supply voltage. The voltage regulator may be enabled / disabled through a separate pin.

A battery monitor may optionally be used to monitor the unregulated power supply voltage. The battery monitor is configurable through the SPI interface.

9 Application Circuit

Few external components are required for the operation of **CC2420**. A typical application circuit is shown in Figure 4. The external components shown are described in Table 1 and typical values are given in Table 2. Note that most decoupling capacitors are not shown on the application circuits. For the complete reference design please refer to Texas Instrument's web site: <http://www.ti.com>.

9.1 Input / output matching

The RF input/output is high impedance and differential. The optimum differential load for the RF port is $95+j187\ \Omega$.

When using an unbalanced antenna such as a monopole, a balun should be used in order to optimise performance. The balun can be implemented using low-cost discrete inductors and capacitors only or in combination with transmission lines.

Figure 3 shows the balun implemented in a two-layer reference design. It consists of a half wave transmission line, C81, L61, L71 and L81. The circuit will present the optimum RF termination to **CC2420** with a $50\ \Omega$ load on the antenna connection. This circuit has improved EVM performance, sensitivity and harmonic suppression compared to the design in Figure 4. Please refer to the input/output matching section on page 54 for more details.

The balun in Figure 4 consists of C61, C62, C71, C81, L61, L62 and L81, and will present the optimum RF termination to **CC2420** with a $50\ \Omega$ load on the antenna connection. A low pass filter may be added to add margin to the FCC requirement on second harmonic level.

If a balanced antenna such as a folded dipole is used, the balun can be omitted. If the antenna also provides a DC path from the TXRX_SWITCH pin to the RF pins, inductors are not needed for DC bias.

Figure 5 shows a suggested application circuit using a differential antenna. The antenna type is a standard folded dipole. The dipole has a virtual ground point; hence bias is provided without degradation in antenna performance.

9.2 Bias resistor

The bias resistor R451 is used to set an accurate bias current.

9.3 Crystal

An external crystal with two loading capacitors (C381 and C391) is used for the crystal oscillator. See page 53 for details.

9.4 Voltage regulator

The on chip voltage regulator supplies all 1.8 V power supply inputs. C42 is required for stability of the regulator. A series resistor may be used to comply with the ESR requirement.

9.5 Power supply decoupling and filtering

Proper power supply decoupling must be used for optimum performance. The placement and size of the decoupling capacitors and the power supply filtering are very important to achieve the best performance in an application. Texas Instruments provides a compact reference design that should be followed very closely..

Ref	Description
C42	Voltage regulator load capacitance
C61	Balun and match
C62	DC block to antenna and match
C71	Front-end bias decoupling and match
C81	Balun and match
C381	16MHz crystal load capacitor, see page 53
C391	16MHz crystal load capacitor, see page 53
L61	DC bias and match
L62	DC bias and match
L71	DC bias and match
L81	Balun and match
R451	Precision resistor for current reference generator
XTAL	16MHz crystal, see page 53

Table 1. Overview of external components

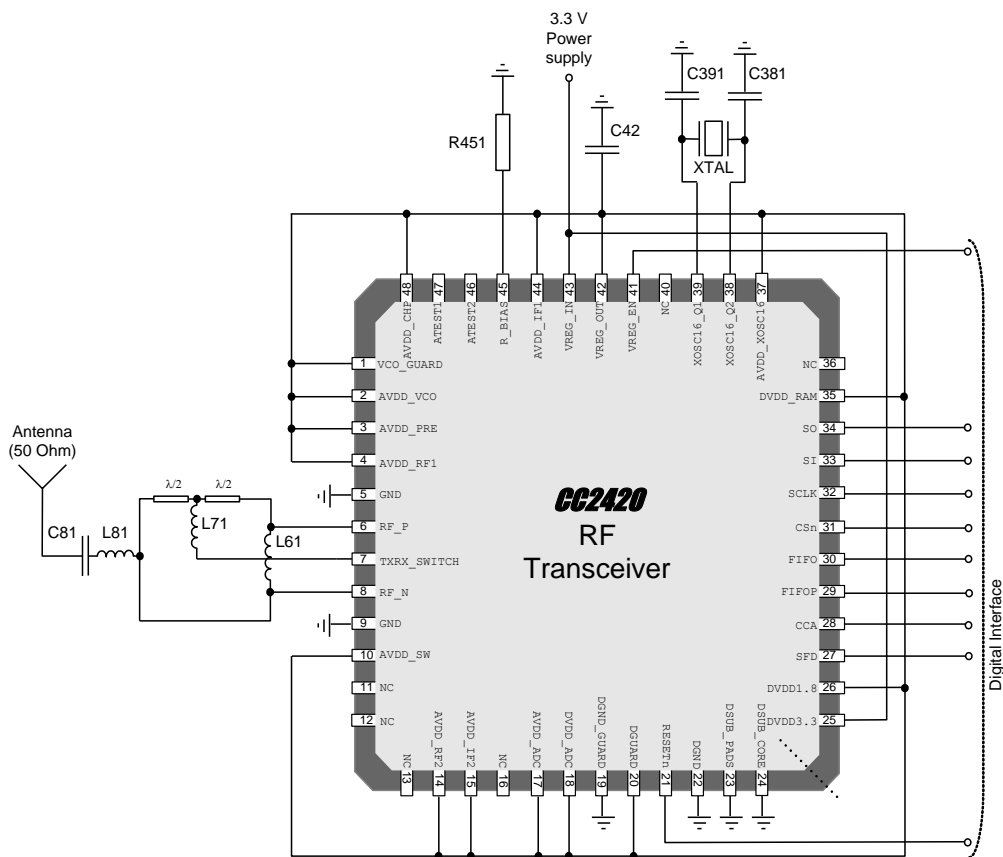

Figure 3. Typical application circuit with transmission line balun for single-ended operation

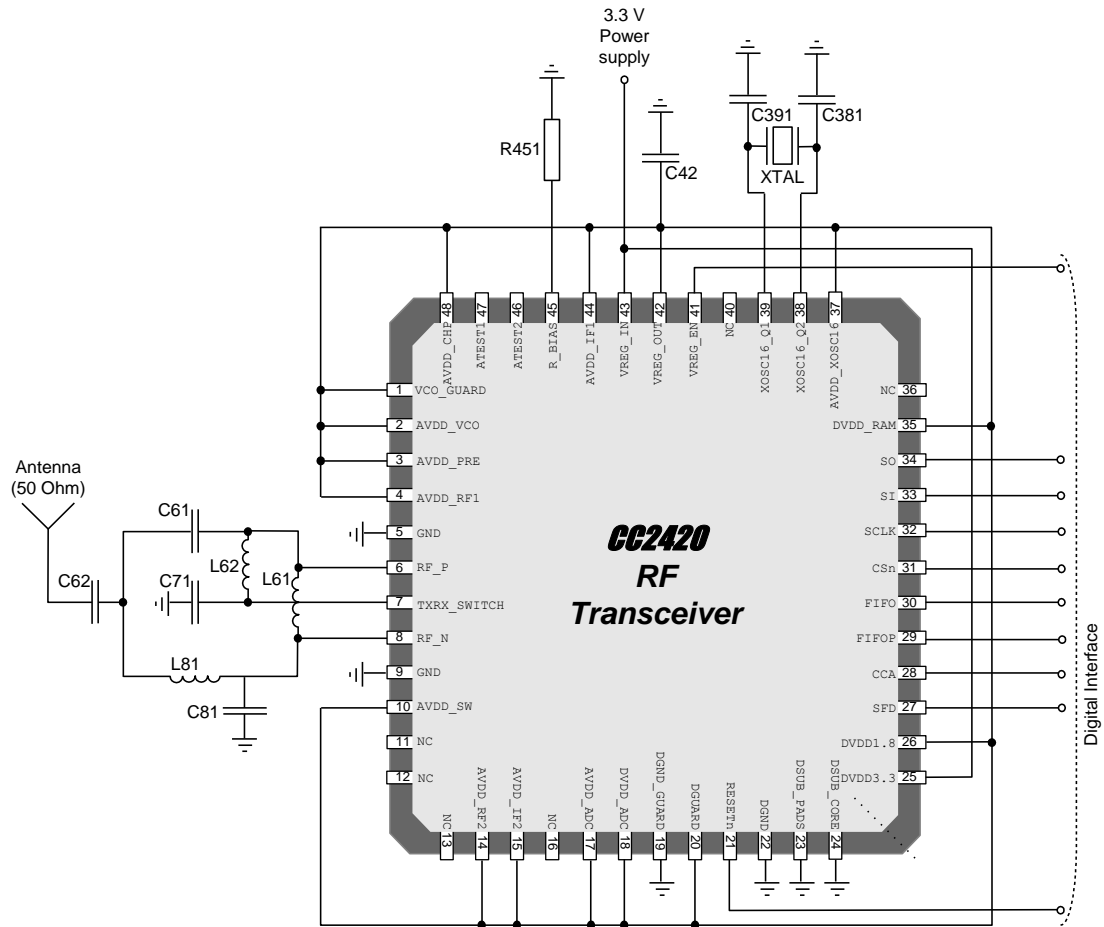

Figure 4. Typical application circuit with discrete balun for single-ended operation

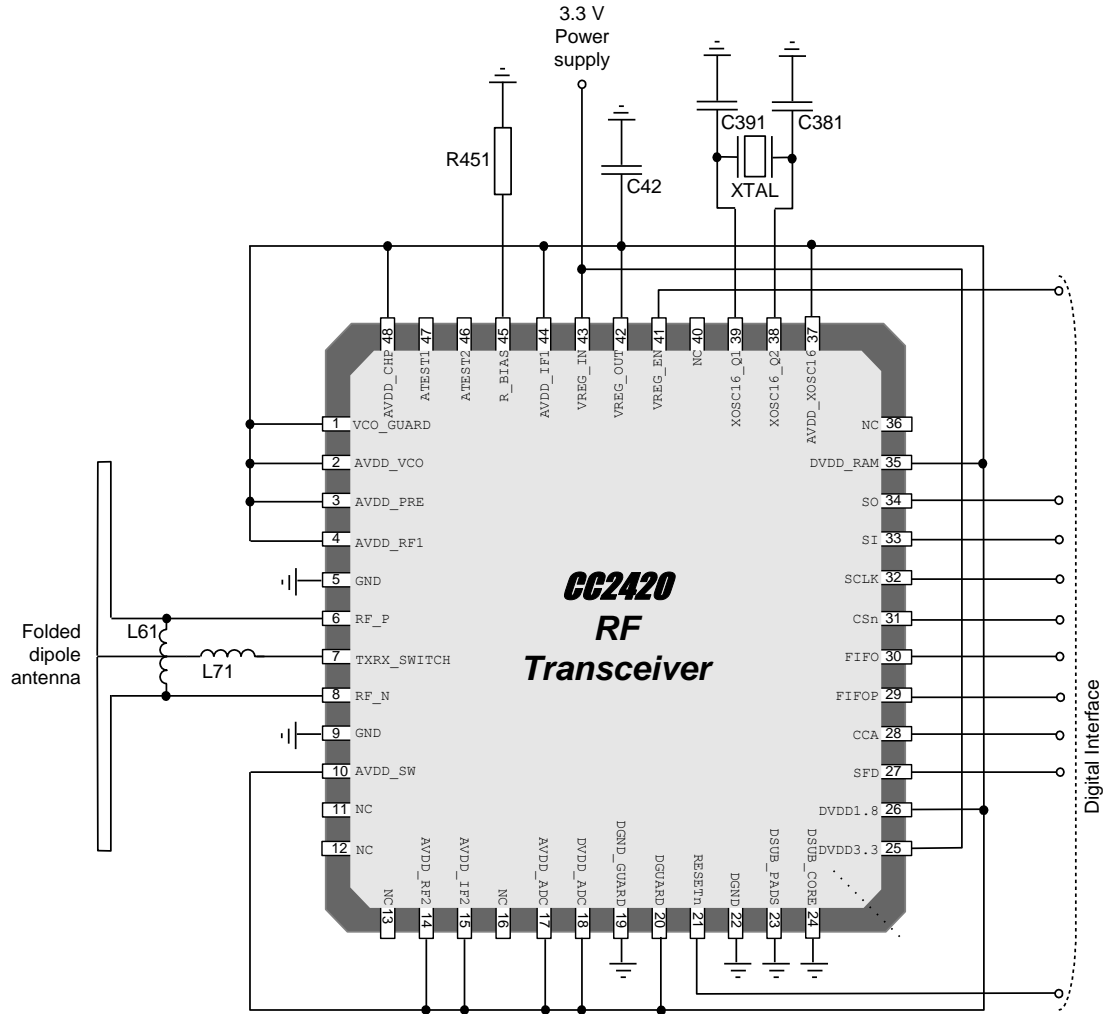

Figure 5. Suggested application circuit with differential antenna (folded dipole)

Item	Single ended output, transmission line balun	Single ended output, discrete balun	Differential antenna
C42	10 μ F, $0.5\Omega < \text{ESR} < 5\Omega$	10 μ F, $0.5\Omega < \text{ESR} < 5\Omega$	10 μ F, $0.5\Omega < \text{ESR} < 5\Omega$
C61	Not used	0.5 pF, +/- 0.25pF, NP0, 0402	Not used
C62	Not used	5.6 pF, +/- 0.25pF, NP0, 0402	Not used
C71	Not used	5.6 pF, 10%, X5R, 0402	Not used
C81	5.6 pF, +/- 0.25pF, NP0, 0402	0.5 pF, +/- 0.25pF, NP0, 0402	Not used
C381	27 pF, 5%, NP0, 0402	27 pF, 5%, NP0, 0402	27 pF, 5%, NP0, 0402
C391	27 pF, 5%, NP0, 0402	27 pF, 5%, NP0, 0402	27 pF, 5%, NP0, 0402
L61	8.2 nH, 5%, Monolithic/multilayer, 0402	7.5 nH, 5%, Monolithic/multilayer, 0402	27 nH, 5%, Monolithic/multilayer, 0402
L62	Not used	5.6 nH, 5%, Monolithic/multilayer, 0402	Not used
L71	22 nH, 5%, Monolithic/multilayer, 0402	Not used	12 nH, 5%, Monolithic/multilayer, 0402
L81	1.8 nH, +/- 0.3nH, Monolithic/multilayer, 0402	7.5 nH, 5%, Monolithic/multilayer, 0402	Not used
R451	43 k Ω , 1%, 0402	43 k Ω , 1%, 0402	43 k Ω , 1%, 0402
XTAL	16 MHz crystal, 16 pF load (C_L), ESR < 60 Ω	16 MHz crystal, 16 pF load (C_L), ESR < 60 Ω	16 MHz crystal, 16 pF load (C_L), ESR < 60 Ω

Table 2. Bill of materials for the application circuits

10 IEEE 802.15.4 Modulation Format

This section is meant as an introduction to the 2.4 GHz direct sequence spread spectrum (DSSS) RF modulation format defined in IEEE 802.15.4. For a complete description, please refer to [1].

The modulation and spreading functions are illustrated at block level in Figure 6 [1]. Each byte is divided into two symbols, 4 bits each. The least significant symbol is transmitted first. For multi-byte fields, the

least significant byte is transmitted first, except for security related fields where the most significant byte is transmitted first.

Each symbol is mapped to one out of 16 pseudo-random sequences, 32 chips each. The symbol to chip mapping is shown in Table 3. The chip sequence is then transmitted at 2 MChips/s, with the least significant chip (C_0) transmitted first for each symbol.

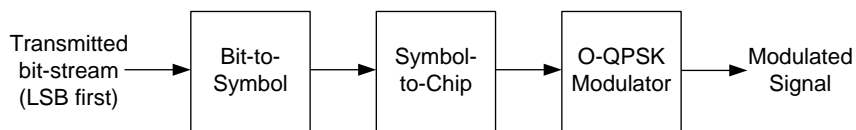

Figure 6. Modulation and spreading functions [1]

Symbol	Chip sequence ($C_0, C_1, C_2, \dots, C_{31}$)
0	11011001110000110101001000101110
1	11101101100111000011010100100010
2	00101110110110011100001101010010
3	00100010111011011001110000110101
4	01010010001011101101100111000011
5	00110101001000101110110110011100
6	11000011010100100010111011011001
7	10011100001101010010001011101101
8	10001100100101100000011101111011
9	10111000110010010110000001110111
10	01111011100011001001011000000111
11	01110111101110001100100101100000
12	00000111011110111000110010010110
13	01100000011101111011100011001001
14	10010110000001110111101110001100
15	11001001011000000111011110111000

Table 3. IEEE 802.15.4 symbol-to-chip mapping [1]

The modulation format is Offset – Quadrature Phase Shift Keying (O-QPSK) with half-sine chip shaping. This is equivalent to MSK modulation. Each chip

is shaped as a half-sine, transmitted alternately in the I and Q channels with one half chip period offset. This is illustrated for the zero-symbol in Figure 7.

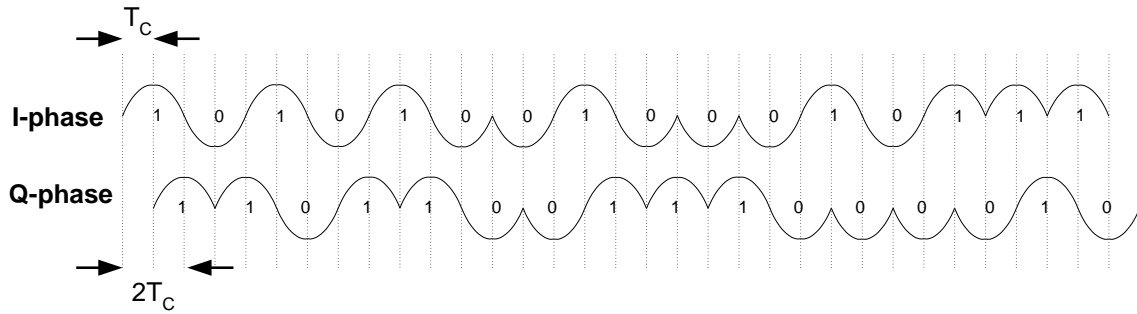

Figure 7. I / Q Phases when transmitting a zero-symbol chip sequence, $T_C = 0.5 \mu s$

11 Configuration Overview

CC2420 can be configured to achieve the best performance for different applications. Through the programmable configuration registers the following key parameters can be programmed:

- Receive / transmit mode
- RF channel selection
- RF output power
- Power-down / power-up mode
- Crystal oscillator power-up / power down
- Clear Channel Assessment mode
- Packet handling hardware support
- Encryption / Authentication modes

12 Evaluation Software

Texas Instruments (TI) provides users of **CC2420** with a software program, SmartRF® Studio (Windows interface) which may be used for radio performance and functionality evaluation. SmartRF®

Studio can be downloaded from TI's web page: <http://www.ti.com>. Figure 8 shows the user interface of the **CC2420** configuration software.

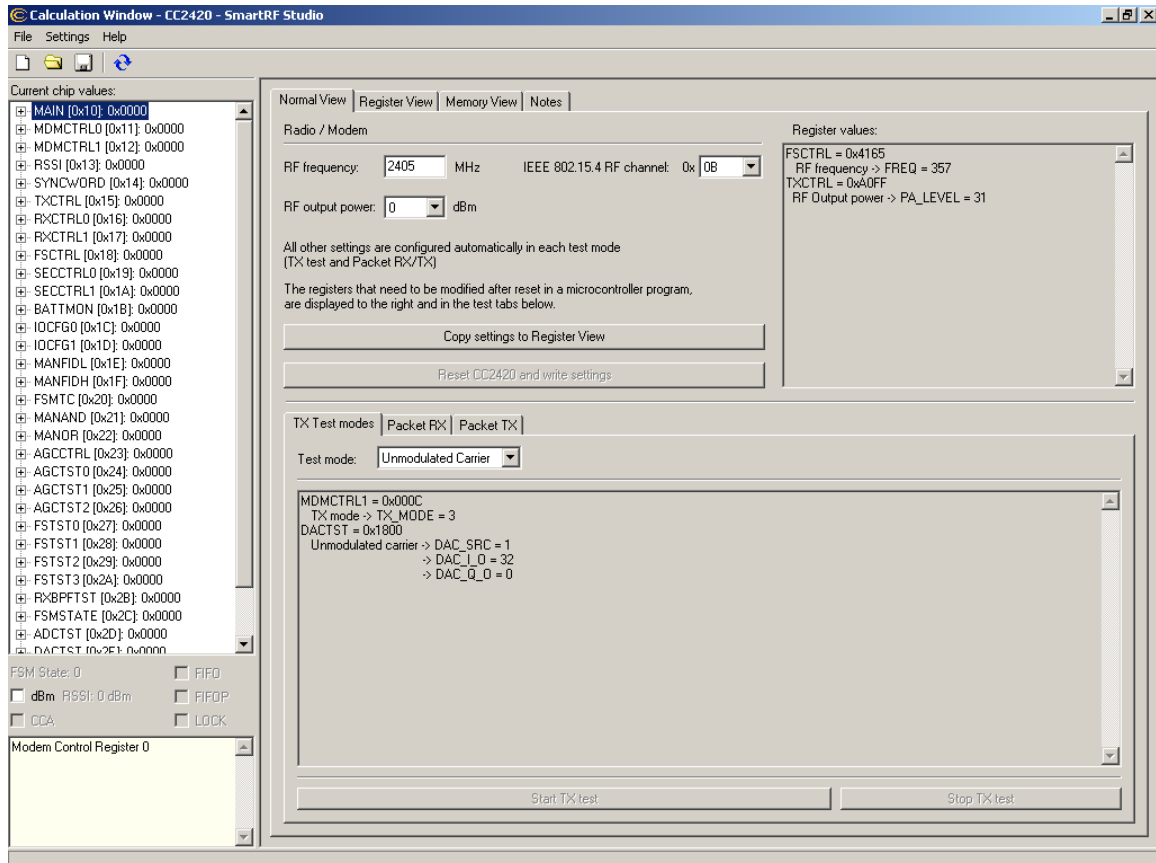

Figure 8. SmartRF Studio user interface

13 4-wire Serial Configuration and Data Interface

CC2420 is configured via a simple 4-wire SPI-compatible interface (pins *SI*, *SO*, *SCLK* and *CS_n*) where **CC2420** is the slave. This interface is also used to read and write buffered data (see page 39). All address and data transfer on the SPI interface is done most significant bit first.

13.1 Pin configuration

The digital inputs *SCLK*, *SI* and *CS_n* are high-impedance inputs (no internal pull-up) and should have external pull-ups if not driven. *SO* is high-impedance when *CS_n* is high. An external pull-up should be used at *SO* to prevent floating input at microcontroller. Unused I/O pins on the MCU can be set to outputs with a fixed '0' level to avoid leakage currents.

13.2 Register access

There are 33 16-bit configuration and status registers, 15 command strobe registers, and two 8-bit registers to access the separate transmit and receive FIFOs. Each of the 50 registers is addressed by a 6-bit address. The RAM/Register bit (bit 7) must be cleared for register access. The Read/Write bit (bit 6) selects a read or a write operation and makes up the 8-bit address field together with the 6-bit address.

In each register read or write cycle, 24 bits are sent on the *SI*-line. The *CS_n* pin (Chip Select, active low) must be kept low during this transfer. The bit to be sent first is the

RAM/Register bit (set to 0 for register access), followed by the R/W bit (0 for write, 1 for read). The following 6 bits are the address-bits (A5:0). A5 is the most significant bit of the address and is sent first. The 16 data-bits are then transferred (D15:0), also MSB first. See Figure 9 for an illustration.

The configuration registers can also be read by the microcontroller via the same configuration interface. The R/W bit must be set high to initiate the data read-back. **CC2420** then returns the data from the addressed register on the 16 clock cycles following the register address. The *SO* pin is used as the data output and must be configured as an input by the microcontroller.

The timing for the programming is also shown in Figure 9 with reference to Table 4. The clocking of the data on *SI* into the **CC2420** is done on the positive edge of *SCLK*. When the last bit, D0, of the 16 data-bits has been written, the data word is loaded in the internal configuration register.

Multiple registers may be written without releasing *CS_n*, as described in the Multiple SPI access section on page 31.

The register data will be retained during power down mode, but not when the power-supply is turned off (e.g. by disabling the voltage regulator using the *VREG_EN* pin). The registers can be programmed in any order.

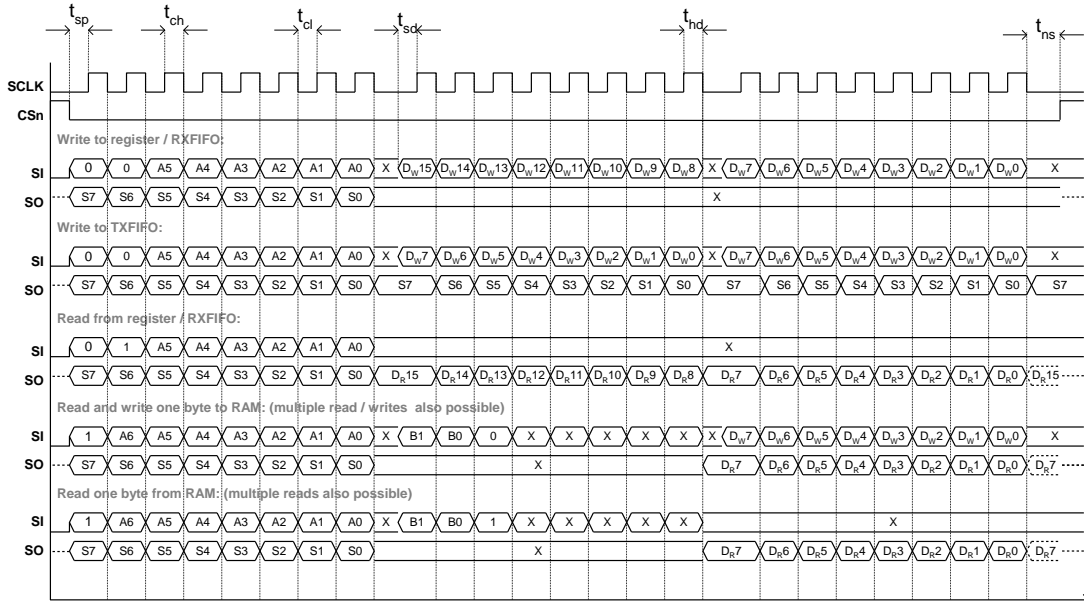

Figure 9. SPI timing diagram

Parameter	Symbol	Min	Max	Units	Conditions
SCLK, clock frequency	F_{SCLK}		10	MHz	
SCLK low pulse duration	t_{cl}	25		ns	The minimum time SCLK must be low.
SCLK high pulse duration	t_{ch}	25		ns	The minimum time SCLK must be high.
CSn setup time	t_{sp}	25		ns	The minimum time CSn must be low before the first <i>positive</i> edge of SCLK.
CSn hold time	t_{ns}	25		ns	The minimum time CSn must be held low after the last <i>negative</i> edge of SCLK.
SI setup time	t_{sd}	25		ns	The minimum time data on SI must be ready before the <i>positive</i> edge of SCLK.
SI hold time	t_{hd}	25		ns	The minimum time data must be held at SI, after the <i>positive</i> edge of SCLK.
Rise time	t_{rise}		100	ns	The maximum rise time for SCLK and CSn
Fall time	t_{fall}		100	ns	The maximum fall time for SCLK and CSn

Note: The set-up- and hold-times refer to 50% of VDD.

Table 4. SPI timing specification

13.3 Status byte

During transfer of the register access byte, command strobes, the first RAM address byte and data transfer to the TXFIFO, the **CC2420** status byte is returned on the SO

pin. The status byte contains 6 status bits which are described in Table 5.

Issuing a SNOP (no operation) command strobe may be used to read the status byte. It may also be read during access to

chip functions such as register or FIFO access.

Bit #	Name	Description
7	-	Reserved, ignore value
6	XOSC16M_STABLE	Indicates whether the 16 MHz oscillator is running or not 0 : The 16 MHz crystal oscillator is not running 1 : The 16 MHz crystal oscillator is running
5	TX_UNDERFLOW	Indicates whether an FIFO underflow has occurred during transmission. Must be cleared manually with a SFLUSHTX command strobe. 0 : No underflow has occurred 1 : An underflow has occurred
4	ENC_BUSY	Indicates whether the encryption module is busy 0 : Encryption module is idle 1 : Encryption module is busy
3	TX_ACTIVE	Indicates whether RF transmission is active 0 : RF Transmission is idle 1 : RF Transmission is active
2	LOCK	Indicates whether the frequency synthesizer PLL is in lock or not 0 : The PLL is out of lock 1 : The PLL is in lock
1	RSSI_VALID	Indicates whether the RSSI value is valid or not. 0 : The RSSI value is not valid 1 : The RSSI value is valid, always true when reception has been enabled at least 8 symbol periods (128 us)
0	-	Reserved, ignore value

Table 5. Status byte returned during address transfer and TXFIFO writing

13.4 Command strobes

Command strobes may be viewed as single byte instructions to **CC2420**. By addressing a command strobe register internal sequences will be started. These commands must be used to enable the crystal oscillator, enable receive mode, start decryption etc. All 15 command strobes are listed in Table 11 on page 62.

When the crystal oscillator is disabled (Power Down state in Figure 25 on page 44), only the SXOSCON command strobe may be used. All other command strobes will be ignored and will have no effect. The crystal oscillator must stabilise (see the XOSC16M_STABLE status bit in Table 5) before other command strobes are accepted.

The command strobe register is accessed in the same way as for a register write operation, but no data is transferred. That is, only the RAM/Register bit (set to 0),

R/W bit (set to 0) and the 6 address bits (in the range 0x00 through 0x0E) are written. A command strobe may be followed by any other SPI access without pulling CS_n high, and is executed on the last falling edge on SCLK.

13.5 RAM access

The internal 368 byte RAM may be accessed through the SPI interface. Single or multiple bytes may be read or written sending the address part (2 bytes) only once. The address is then automatically incremented by the **CC2420** hardware for each new byte. Data is read and written one byte at a time, unlike register access where 2 bytes are always required after each address byte.

The crystal oscillator must be running when accessing the RAM.

The RAM/Register bit must be set high to enable RAM access. The 9 bit RAM

address consists of two parts, B1:0 (MSB) selecting one of the three memory banks and A6:0 (LSB) selecting the address within the selected bank. The RAM is divided into three memory banks: TXFIFO (bank 0), RXFIFO (bank 1) and security (bank 2). The FIFO banks are 128 bytes each, while the security bank is 112 bytes.

A6:0 is transmitted directly after the RAM/Register bit as shown in Figure 9. For RAM access, a second byte is also required before the data transfer. This byte contains B1:0 in bits 7 and 6, followed by the R/W bit (0 for read+write, 1 for read). Bits 4 through 0 are don't care as shown in Figure 9.

For RAM write, data to be written must be input on the SI pin directly after the second address byte. RAM data read is output on the SO pin simultaneously, but may be ignored by the user if only writing is of interest.

For RAM read, the selected byte(s) are output on the SO pin directly after the second address byte.

See Figure 10 for an illustration on how multiple RAM bytes may be read or written in one operation.

The RAM memory space is shown in Table 6. The lower 256 bytes are used to store FIFO data. Note that RAM access should never be used for FIFO write operations because the FIFO counter will not be updated. Use RXFIFO and TXFIFO access instead as described in section FIFO access.

As with register data, data stored in RAM will be retained during power down mode, but not when the power-supply is turned off (e.g. by disabling the voltage regulator using the VREG_EN pin).

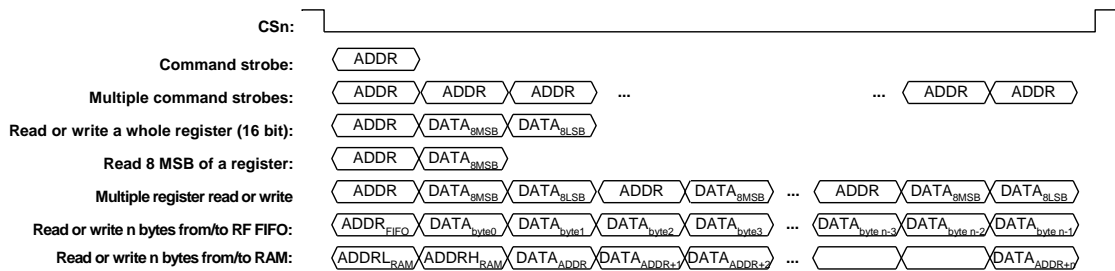

Note: FIFO and RAM access must be terminated with setting the CSn pin high. Command strobes and register access may be followed by any other access, since they are completed on the last negative edge on SCLK. They may however also be terminated with setting CSn high, if desirable, e.g. for reading only 8 bits from a configuration register.

Figure 10. Configuration registers write and read operations via SPI

Address	Byte Ordering	Name	Description
0x16F – 0x16C	-	-	Not used
0x16B – 0x16A	MSB LSB	SHORTADR	16-bit Short address, used for address recognition.
0x169 – 0x168	MSB LSB	PANID	16-bit PAN identifier, used for address recognition.
0x167 – 0x160	MSB LSB	IEEEADR	64-bit IEEE address of current node, used for address recognition.
0x15F – 0x150	MSB LSB	CBCSTATE	Temporary storage for CBC-MAC calculations
0x14F – 0x140	MSB (Flags) LSB	TXNONCE / TXCTR	Transmitter nonce for in-line authentication and transmitter counter for in-line encryption.
0x13F – 0x130	MSB LSB	KEY1	Encryption key 1
0x12F – 0x120	MSB LSB	SABUF	Stand-alone encryption buffer, for plaintext input and ciphertext output
0x11F – 0x110	MSB (Flags) LSB	RXNONCE / RXCTR	Receiver nonce for in-line authentication or receiver counter for in-line decryption.
0x10F – 0x100	MSB LSB	KEY0	Encryption key 0
0x0FF – 0x080	MSB LSB	RXFIFO	128 bytes receive FIFO
0x07F – 0x000	MSB LSB	TXFIFO	128 bytes transmit FIFO

Table 6. CC2420 RAM Memory Space

13.6 FIFO access

The TXFIFO and RXFIFO may be accessed through the TXFIFO (0x3E) and RXFIFO (0x3F) registers.

The TXFIFO is write only, but may be read back using RAM access as described in the previous section. Data is read and written one byte at a time, as with RAM access. The RXFIFO is both writeable and readable. Writing to the RXFIFO should however only be done for debugging or for using the RXFIFO for security operations (decryption / authentication).

The crystal oscillator must be running when accessing the FIFOs.

When writing to the TXFIFO, the status byte (see Table 5) is output for each new data byte on SO, as shown in Figure 9. This could be used to detect TXFIFO underflow (see section RF Data Buffering section on page 39) while writing data to the TXFIFO.

Multiple FIFO bytes may be accessed in one operation, as with the RAM access.

FIFO access can only be terminated by setting the CS_n pin high once it has been started.

The FIFO and FIFOP pins also provide additional information on the data in the receive FIFO, as will be described in the Microcontroller Interface and Pin Description section on page 32. Note that the FIFO and FIFOP pins only apply to the RXFIFO. The TXFIFO has its underflow flag in the status byte.

The TXFIFO may be flushed by issuing a SFLUSHTX command strobe. Similarly, a SFLUSHRX command strobe will flush the receive FIFO.

13.7 Multiple SPI access

Register access, command strobes, FIFO access and RAM access may be issued continuously without setting CS_n high. E.g. the user may issue a command strobe, a register write and writing 3 bytes to the TXFIFO in one operation, as illustrated in Figure 11. The only exception is that FIFO and RAM access must be terminated by setting CS_n high.

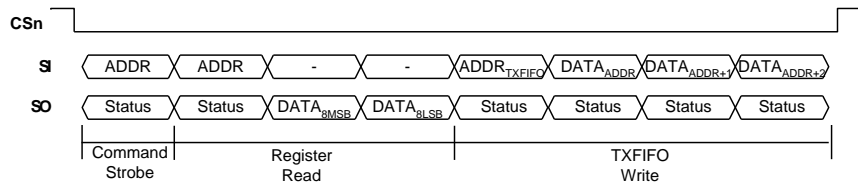

Figure 11. Multiple SPI Access Example

14 Microcontroller Interface and Pin Description

When used in a typical system, **CC2420** will interface to a microcontroller. This microcontroller must be able to:

- Program **CC2420** into different modes, read and write buffered data, and read back status information via the 4-wire SPI-bus configuration interface (SI, SO, SCLK and CSn).
- Interface to the receive and transmit FIFOs using the FIFO and FIFOP status pins.
- Interface to the CCA pin for clear channel assessment.
- Interface to the SFD pin for timing information (particularly for beaconing networks).

microcontroller uses 4 I/O pins for the SPI configuration interface (SI, SO, SCLK and CSn). SO should be connected to an input at the microcontroller. SI, SCLK and CSn must be microcontroller outputs. Preferably the microcontroller should have a hardware SPI interface.

The microcontroller pins connected to SI, SO and SCLK can be shared with other SPI-interface devices. SO is a high impedance output as long as CSn is not activated (active low).

CSn should have an external pull-up resistor or be set to a high level when the voltage regulator is turned off in order to prevent the input from floating. SI and SCLK should be set to a defined level to prevent the inputs from floating.

14.1 Configuration interface

A **CC2420** to microcontroller interface example is shown in Figure 12. The

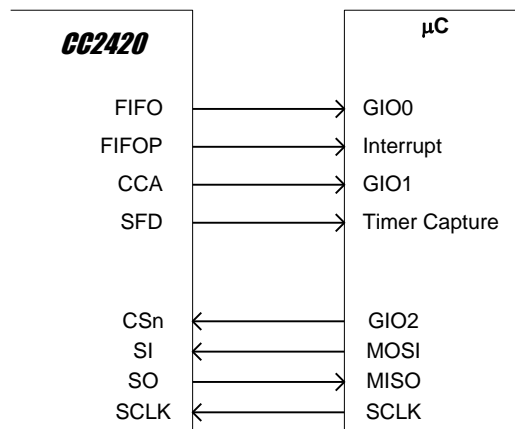

Figure 12. Microcontroller interface example

14.2 Receive mode

In receive mode, the `SFD` pin goes active after the start of frame delimiter (SFD) field has been completely received. If address recognition is disabled or is successful, the `SFD` pin goes inactive again only after the last byte of the MPDU has been received. If the received frame fails address recognition, the `SFD` pin goes inactive immediately. This is illustrated in Figure 13.

The `FIFO` pin is active when there are one or more data bytes in the RXFIFO. The first byte to be stored in the RXFIFO is the length field of the received frame, i.e. the `FIFO` pin goes active when the length field is written to the RXFIFO. The `FIFO` pin then remains active until the RXFIFO is empty.

If a previously received frame is completely or partially inside the RXFIFO, the `FIFO` pin will remain active until the RXFIFO is empty.

The `FIFOP` pin is active when the number of unread bytes in the RXFIFO exceeds the threshold programmed into `IOCFG0.FIFOP_THR`. When address recognition is enabled the `FIFOP` pin will remain inactive until the incoming frame passes address recognition, even if the number of bytes in the RXFIFO exceeds the programmed threshold.

The `FIFOP` pin will also go active when the last byte of a new packet is received, even if the threshold is not exceeded. If so, the `FIFOP` pin will go inactive once one byte has been read out of the RXFIFO.

When address recognition is enabled, data should not be read out of the RXFIFO before the address is completely received, since the frame may be automatically flushed by CC2420 if it fails address

recognition. This may be handled by using the `FIFOP` pin, since this pin does not go active until the frame passes address recognition.

Figure 14 shows an example of pin activity when reading a packet from the RXFIFO. In this example, the packet size is 8 bytes, `IOCFG0.FIFOP_THR = 3` and `MODEMCTRL0.AUTOCRC` is set. The length will be 8 bytes, `RSSI` will contain the average RSSI level during reception of the packet and `FCS/corr` contains information of FCS check result and the correlation levels.

14.3 RXFIFO overflow

The RXFIFO can only contain a maximum of 128 bytes at a given time. This may be divided between multiple frames, as long as the total number of bytes is 128 or less. If an overflow occurs in the RXFIFO, this is signalled to the microcontroller by making the `FIFO` pin go inactive while the `FIFOP` pin is active. Data already in the RXFIFO will not be affected by the overflow, i.e. frames already received may be read out.

A `SFLUSHRX` command strobe is required after an RXFIFO overflow to enable reception of new data. Note that the `SFLUSHRX` command strobe should be issued twice to ensure that the `SFD` pin goes back to its inactive state.

For security enabled frames, the MAC layer must read the source address of the received frame before it can decide which key to use to decrypt or authenticate. This data must therefore not be overwritten even if it has been read out of the RXFIFO by the microcontroller. If the `SECCTRL0.RXFIFO_PROTECTION` control bit is set, **CC2420** also protects the frame header of security enabled frames until decryption has been performed. If no MAC security is used or if it is implemented outside the **CC2420**, this bit may be cleared to achieve optimal use of the RXFIFO.

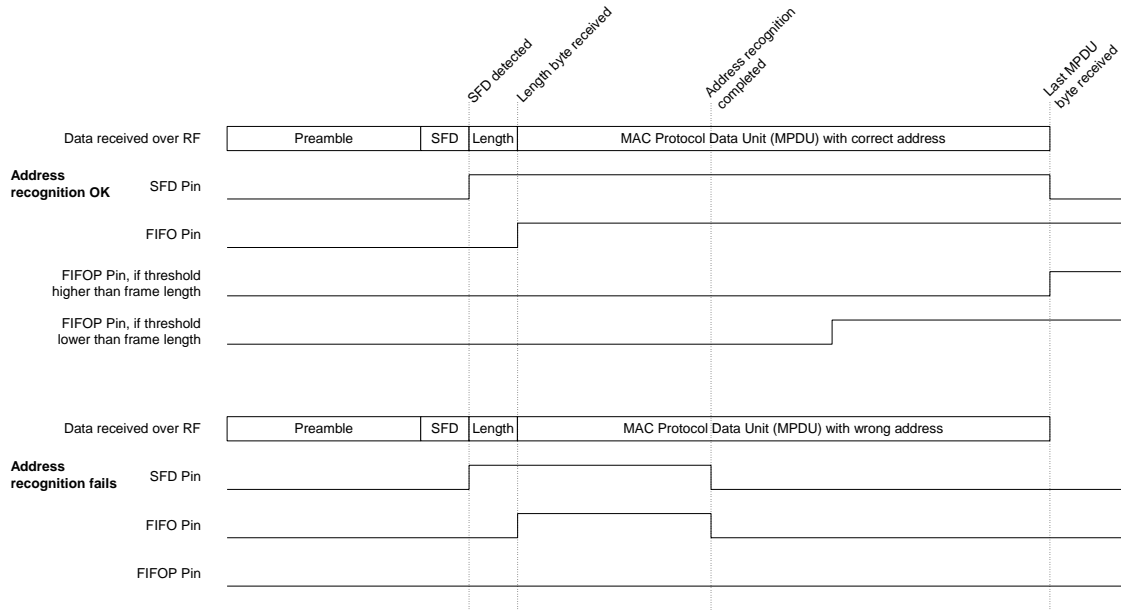

Figure 13. Pin activity examples during receive

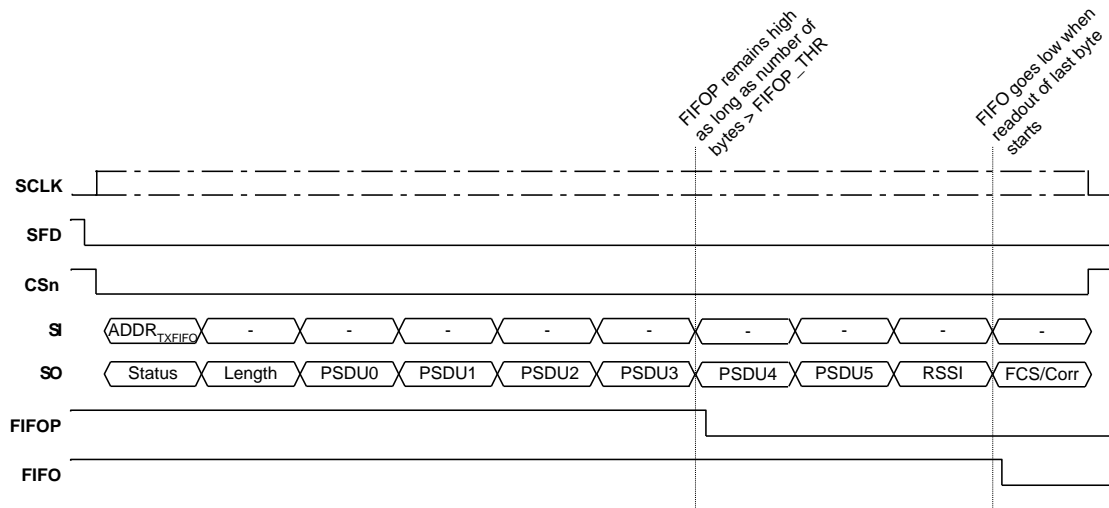

Figure 14. Example of pin activity when reading RXFIFO.

14.4 Transmit mode

During transmit the `FIFO` and `FIFOP` pins are still only related to the `RXFIFO`. The `SFD` pin is however active during transmission of a data frame, as shown in Figure 15.

The `SFD` pin goes active when the `SFD` field has been completely transmitted. It goes inactive again when the complete MPDU (as defined by the length field) has been transmitted or if an underflow is

detected. See the RF Data Buffering section on page 39 for more information on `TXFIFO` underflow.

As can be seen from comparing Figure 13 and Figure 15, the `SFD` pin behaves very similarly during reception and transmission of a data frame. If the `SFD` pins of the transmitter and the receiver are compared during the transmission of a data frame, a small delay of approximately 2 μ s can be seen because of bandwidth limitations in both the transmitter and the receiver.

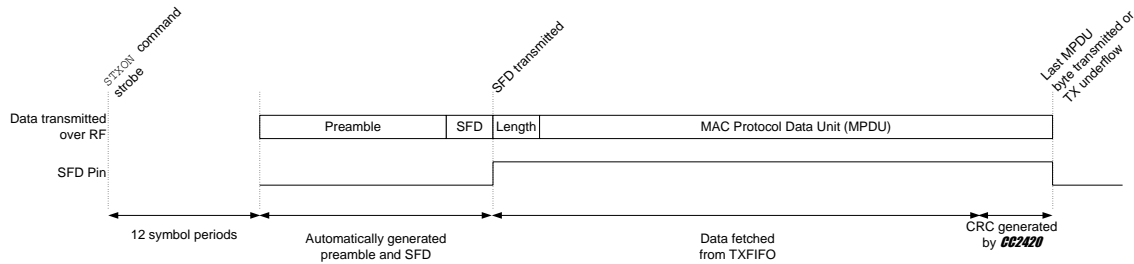

Figure 15. Pin activity example during transmit

14.5 General control and status pins

In receive mode, the `FIFOP` pin can be used to interrupt the microcontroller when a threshold has been exceeded or a complete frame has been received. This pin should then be connected to a microcontroller interrupt pin.

In receive mode, the `FIFO` pin can be used to detect if there is data at all in the receive `FIFO`.

The `SFD` pin can be used to extract the timing information of transmitted and

received data frames. The `SFD` pin will go active when a start of frame delimiter has been completely detected / transmitted. The `SFD` pin should preferably be connected to a timer capture pin on the microcontroller.

For debug purposes, the `SFD` and `CCA` pins can be used to monitor several status signals as selected by the `IOCFG1` register. See Table 12 and Table 13 for available signals.

The polarity of `FIFO`, `FIFOP`, `SFD` and `CCA` can be controlled by the `IOCFG0` register (address 0x1C).

15 Demodulator, Symbol Synchroniser and Data Decision

The block diagram for the **CC2420** demodulator is shown in Figure 16. Channel filtering and frequency offset compensation is performed digitally. The signal level in the channel is estimated to generate the `RSSI` level (see the `RSSI / Energy Detection` section on page 48 for more information). Data filtering is also included for enhanced performance.

With the ± 40 ppm frequency accuracy requirement from [1], a compliant receiver must be able to compensate for up to 80 ppm or 200 kHz. The **CC2420** demodulator tolerates up to 300 kHz offset without significant degradation of the receiver performance.

Soft decision is used at the chip level, i.e. the demodulator does not make a decision for each chip, only for each received symbol. De-spreading is performed using over sampled symbol correlators. Symbol

synchronisation is achieved by a continuous start of frame delimiter (SFD) search.

When a SFD is detected, data is written to the `RXFIFO` and may be read out by the microcontroller at a lower bit rate than the 250 kbps generated by the receiver.

The **CC2420** demodulator also handles symbol rate errors in excess of 120 ppm without performance degradation. Resynchronisation is performed continuously to adjust for error in the incoming symbol rate.

The `RXCTRL1.RXBPF_LOCUR` control bit should be written to 1.

The `MDMCTRL1.CORR_THR` control bits are by default set to 20 defining the threshold for detecting IEEE 802.15.4 start of frame delimiters.

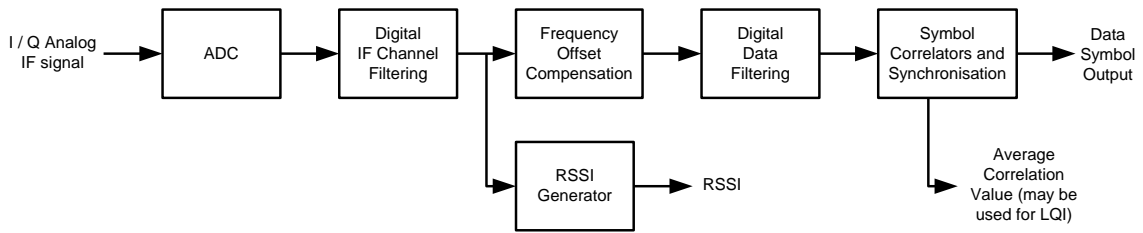

Figure 16. Demodulator Simplified Block Diagram

16 Frame Format

CC2420 has hardware support for parts of the IEEE 802.15.4 frame format. This section gives a brief summary to the IEEE 802.15.4 frame format, and describes how **CC2420** is set up to comply with this.

Figure 17 [1] shows a schematic view of the IEEE 802.15.4 frame format. Similar figures describing specific frame formats (data frames, beacon frames, acknowledgment frames and MAC command frames) are included in [1].

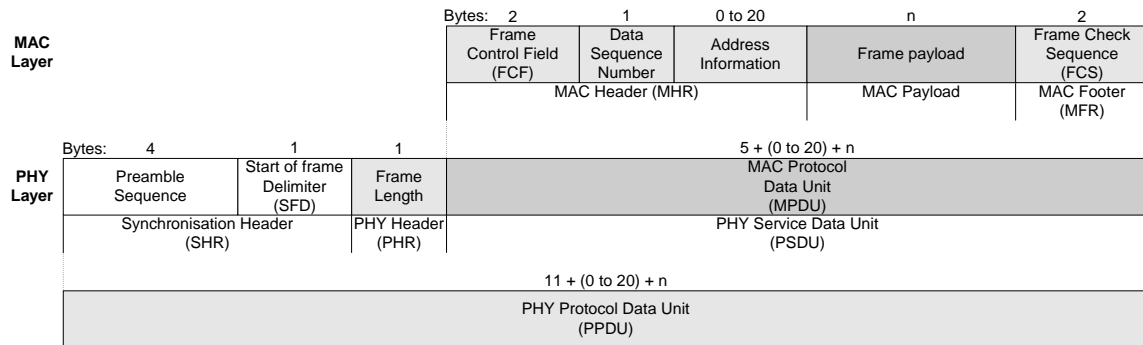

Figure 17. Schematic view of the IEEE 802.15.4 Frame Format [1]

16.1 Synchronisation header

The synchronisation header (SHR) consists of the preamble sequence followed by the start of frame delimiter (SFD). In [1], the preamble sequence is defined to be 4 bytes of 0x00. The SFD is one byte, set to 0xA7.

In **CC2420**, the preamble length and SFD is configurable. The default values are compliant with [1]. Changing these values will make the system non-compliant to IEEE 802.15.4.

A synchronisation header is always transmitted first in all transmit modes.

The preamble sequence length can be set by `MDMCTRL0.PREAMBLE_LENGTH`, while the SFD is programmed in the `SYNCWORD` register. `SYNCWORD` is 2 bytes long, which gives the user some extra flexibility as described below. Figure 18 shows how the **CC2420** synchronisation header relates to the IEEE 802.15.4 specification.

The programmable preamble length only applies to transmission, it does not affect receive mode. The preamble length should not be set shorter than the default value. Note that 2 of the 8 zero-symbols in the preamble sequence required by [1] are included in the `SYNCWORD` register so that the **CC2420** preamble sequence is only 6 symbols long for compliance with [1]. Two

additional zero symbols in SYNCWORD make **CC2420** compliant with [1].

In reception, **CC2420** synchronises to received zero-symbols and searches for the SFD sequence defined by the SYNCWORD register. The least significant symbols in SYNCWORD set to 0xF will be ignored, while symbols different from 0xF will be required for synchronisation. The default setting of 0xA70F thereby requires one additional zero-symbol for synchronisation. This will reduce the number of false frames detected due to noise.

The following illustrates how the programmed synch word is interpreted during reception by **CC2420**. If SYNCWORD = 0xA7FF, **CC2420** will require the incoming symbol sequence of (from left to right) 0 7

A. If SYNCWORD = 0xA70F, **CC2420** will require the incoming symbol sequence of (from left to right) 0 0 7 A. If SYNCWORD = 0xA700, **CC2420** will require the incoming symbol sequence of (from left to right) 0 0 0 7 A.

In receive mode **CC2420** uses the preamble sequence for symbol synchronisation and frequency offset adjustments. The SFD is used for byte synchronisation, and is not part of the data stored in the receive buffer (RXFIFO).

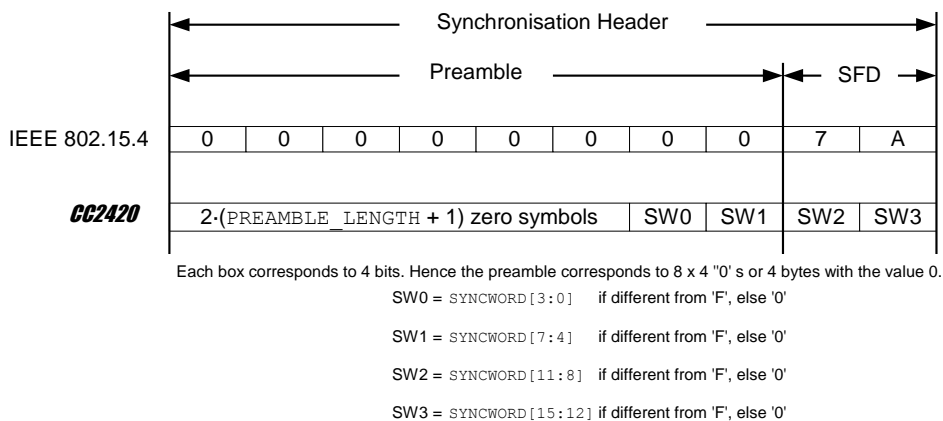

Figure 18. Transmitted Synchronisation Header

16.2 Length field

The frame length field shown in Figure 17 defines the number of bytes in the MPDU. Note that the length field does not include the length field itself. It does however include the FCS (Frame Check Sequence), even if this is inserted automatically by **CC2420** hardware. It also includes the MIC if authentication is used.

The length field is 7 bits and has a maximum value of 127. The most significant bit in the length field is reserved [1], and should be set to zero.

CC2420 uses the length field both for transmission and reception, so this field must always be included. In transmit mode, the length field is used for underflow detection, as described in the FIFO access section on page 31.

16.3 MAC protocol data unit

The FCF, data sequence number and address information follows the length field as shown in Figure 17. Together with the MAC data payload and Frame Check Sequence, they form the MAC Protocol Data Unit (MPDU).

The format of the FCF is shown in Figure 19. Please refer to [1] for details.

There is no hardware support for the data sequence number, this field must be inserted and verified by software.

CC2420 includes hardware address recognition, as described in the Address Recognition section on page 41.

Bits: 0-2	3	4	5	6	7-9	10-11	12-13	14-15
Frame Type	Security Enabled	Frame Pending	Acknowledge request	Intra PAN	Reserved	Destination addressing mode	Reserved	Source addressing mode

Figure 19. Format of the Frame Control Field (FCF) [1]

16.4 Frame check sequence

A 2-byte frame check sequence (FCS) follows the last MAC payload byte as shown in Figure 17. The FCS is calculated over the MPDU, i.e. the length field is not part of the FCS. This field is automatically generated and verified by hardware when the `MODEMCTRL0.AUTOCRC` control bit is set. It is recommended to always have this enabled, except possibly for debug purposes. If cleared, CRC generation and verification must be performed by software.

The FCS polynomial is [1]:

$$x^{16} + x^{12} + x^5 + 1$$

The **CC2420** hardware implementation is shown in Figure 20. Please refer to [1] for further details.

In transmit mode the FCS is appended at the correct position defined by the length field. The FCS is not written to the TXFIFO, but stored in a separate 16-bit register.

In receive mode the FCS is verified by hardware. The user is normally only

interested in the correctness of the FCS, not the FCS sequence itself. The FCS sequence itself is therefore not written to the RXFIFO during receive.

Instead, when `MODEMCTRL0.AUTOCRC` is set the two FCS bytes are replaced by the RSSI value, average correlation value (used for LQI) and CRC OK/not OK. This is illustrated in Figure 21.

The first FCS byte is replaced by the 8-bit RSSI value. This RSSI value is measured over the first 8 symbols following the SFD. See the RSSI section on page 48 for details.

The 7 least significant bits in the last FCS byte are replaced by the average correlation value of the 8 first symbols of the received PHY header (length field) and PHY Service Data Unit (PSDU). This correlation value may be used as a basis for calculating the LQI. See the Link Quality Indication section on page 49 for details.

The most significant bit in the last byte of each frame is set high if the CRC of the received frame is correct and low otherwise.

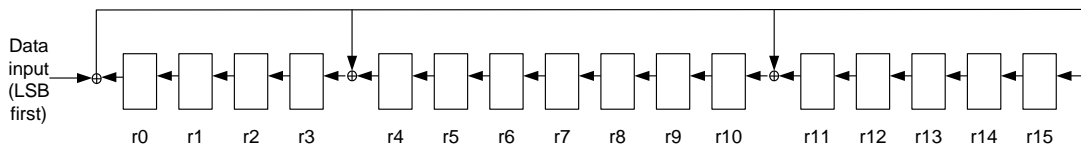

Figure 20. **CC2420** Frame Check Sequence (FCS) hardware implementation [1]

Multiple data frames may be in the RXFIFO simultaneously, as long as the total number of bytes does not exceed 128.

See the RXFIFO overflow section on page 33 for details on how a RXFIFO overflow is detected and signalled.

17.3 Unbuffered, serial mode

Unbuffered mode should be used for evaluation / debugging purposes only. Buffered mode is recommended for all applications.

In unbuffered mode, the FIFO and FIFOP pins are reconfigured as data and data clock pins. The TXFIFO and RXFIFO buffers are not used in this mode. A synchronous data clock is provided by **CC2420** at the FIFOP pin, and the FIFO pin is used as data input/output. The FIFOP clock frequency is 250 kHz when active. This is illustrated in Figure 22.

In serial transmit mode (MDMCTRL1.TX_MODE=1), a synchronisation sequence is inserted at the start of each frame by hardware, as in buffered mode. Data is sampled by **CC2420** on the positive edge of FIFOP and should be updated by the microcontroller on the negative edge of FIFOP. See Figure 22 for an illustration of the timing in serial transmit mode. The SFD and CCA pins retain their normal operation also in serial mode. **CC2420** will remain in serial transmit mode until transmission is turned off manually.

In serial receive mode (MDMCTRL1.RX_MODE=1) byte synchronisation is still performed by **CC2420**. This means that the FIFOP clock pin will remain inactive until a start of frame delimiter has been detected.

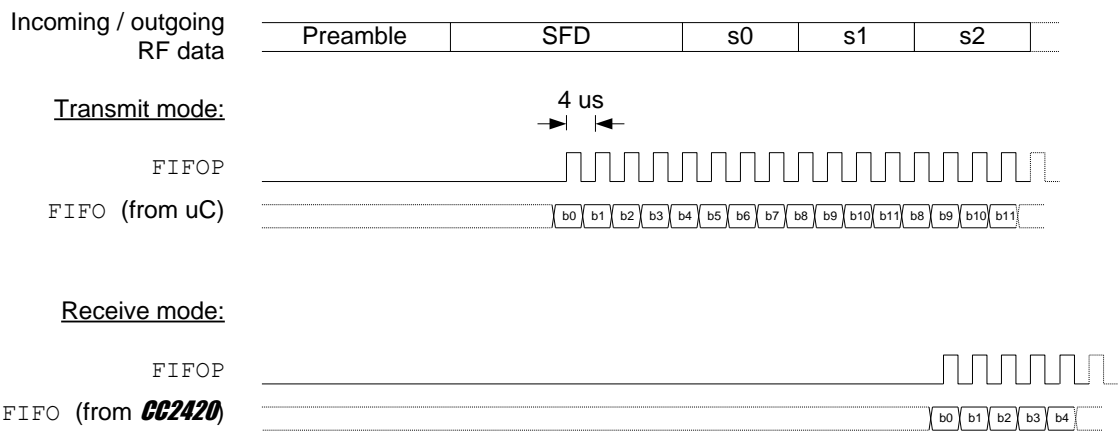

Figure 22. Unbuffered test mode, pin activity

18 Address Recognition

CC2420 includes hardware support for address recognition, as specified in [1]. Hardware address recognition may be enabled / disabled using the `MDMCTRL0.ADR_DECODE` control bit.

Address recognition is based on the following requirements, listed from section 7.5.6.2 in [1]:

- The frame type subfield shall not contain an illegal frame type
- If the frame type indicates that the frame is a beacon frame, the source PAN identifier shall match `macPANId` unless `macPANId` is equal to `0xFFFF`, in which case the beacon frame shall be accepted regardless of the source PAN identifier.
- If a destination PAN identifier is included in the frame, it shall match `macPANId` or shall be the broadcast PAN identifier (`0xFFFF`).
- If a short destination address is included in the frame, it shall match either `macShortAddress` or the broadcast address (`0xFFFF`). Otherwise if an extended destination address is included in the frame, it shall match `aExtendedAddress`.
- If only source addressing fields are included in a data or MAC command frame, the frame shall only be accepted if the device is a PAN coordinator and the source

PAN identifier matches `macPANId`.

If any of the above requirements are not satisfied and address recognition is enabled, **CC2420** will disregard the incoming frame and flush the data from the RXFIFO. Only data from the rejected frame is flushed, data from previously accepted frames may still be in the RXFIFO.

The `IOCFG0.BCN_ACCEPT` control bit must be set when the PAN identifier programmed into **CC2420** RAM is equal to `0xFFFF` and cleared otherwise. This particularly applies to active and passive scans as defined by [1], which requires all received beacons to be processed by the MAC sublayer.

Incoming frames with reserved frame types (FCF frame type subfield is 4, 5, 6 or 7) is however accepted if the `RESERVED_FRAME_MODE` control bit in `MDMCTRL0` is set. In this case, no further address recognition is performed on these frames. This option is included for future expansions of the IEEE 802.15.4 standard.

If a frame is rejected, **CC2420** will only start searching for a new frame after the rejected frame has been completely received (as defined by the length field) to avoid detecting false SFDs within the frame.

The `MDMCTRL0.PAN_COORDINATOR` control bit must be correctly set, since parts of the address recognition procedure requires knowledge about whether the current device is a PAN coordinator or not.

19 Acknowledge Frames

CC2420 includes hardware support for transmitting acknowledge frames, as specified in [1]. Figure 23 shows the format of the acknowledge frame.

If `MDMCTRL0.AUTOACK` is enabled, an acknowledge frame is transmitted for all incoming frames accepted by the address

recognition with the acknowledge request flag set and a valid CRC. `AUTOACK` therefore does not make sense unless also `ADR_DECODE` and `AUTOCRC` are enabled. The sequence number is copied from the incoming frame.

AUTOACK may be used for non-beacon systems as long as the frame pending field (see Figure 19) is cleared. The acknowledge frame is then transmitted 12

symbol periods after the last symbol of the incoming frame. This is as specified by [1] for non-beacon networks.

Bytes:	4	1	1	2	1	2
	Preamble Sequence	Start of Frame Delimiter (SFD)	Frame Length	Frame Control Field (FCF)	Data Sequence Number	Frame Check Sequence (FCS)
	Synchronisation Header (SHR)		PHY Header (PHR)	MAC Header (MHR)		MAC Footer (MFR)

Figure 23. Acknowledge frame format [1]

Two command strobes, SACK and SACKPEND are defined to transmit acknowledge frames with the frame pending field cleared or set, respectively. The acknowledge frame is only transmitted if the CRC is valid.

If a SACK or SACKPEND command strobe is issued while receiving an incoming frame, the acknowledge frame is transmitted 12 symbol periods after the last symbol of the incoming frame. This should be used to transmit acknowledge frames in non-beacon networks. This timing is also illustrated in Figure 24.

For systems using beacons, there is an additional timing requirement that the acknowledge frame transmission should be started on the first backoff-slot boundary (20 symbol periods) at least 12 symbol periods after the last symbol of the incoming frame. This timing must be controlled by the microcontroller by issuing the SACK and SACKPEND command strobe 12 symbol periods before the following backoff-slot boundary, as illustrated in Figure 24.

Using SACKPEND will set the pending data flag for automatically transmitted acknowledge frames using AUTOACK. The pending flag will then be set also for future acknowledge frames, until a SACK command strobe is issued.

Acknowledge frames may be manually transmitted using normal data transmission if desired.

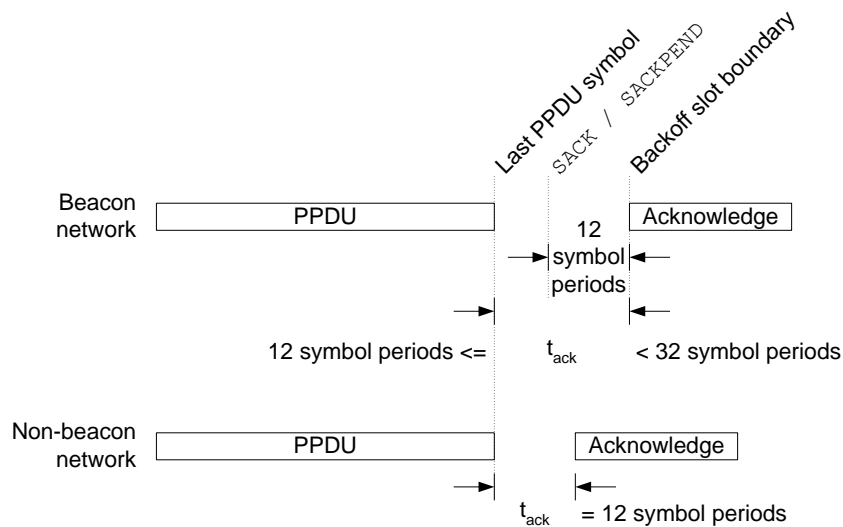

Figure 24. Acknowledge frame timing

20 Radio control state machine

CC2420 has a built-in state machine that is used to switch between different operational states (modes). The change of state is done either by using command strobes or by internal events such as SFD detected in receive mode.

The radio control state machine states are shown in Figure 25. The numbers in brackets refer to the state number readable in the `FSMSTATE` status register. Reading the `FSMSTATE` status register is primarily for test / debug purposes.

Before using the radio in either RX or TX mode, the voltage regulator and crystal oscillator must be turned on and become stable. The voltage regulator and crystal oscillator start-up times are given in the Electrical Specifications section on page 9.

The crystal oscillator is controlled by accessing the `SXOSCON` / `SXOSCOFF` command strobes. The `XOSC16M_STABLE` bit in the status register returned during address transfer indicates whether the oscillator is running and stable or not (see Table 5). This status register can be polled when waiting for the oscillator to start.

For test purposes, the frequency synthesizer (FS) can also be manually calibrated and started by using the `STXCAL` command strobe register. This will not start a transmission before a `STXON` command strobe is issued. This is not shown in Figure 25.

Enabling transmission is done by issuing a `STXON` or `STXONCCA` command strobe.

Turning off RF can be accomplished by using one of the `SRFOFF` or `SXOSCOFF` command strobe registers.

After reset the **CC2420** is in Power Down mode. All configuration registers can then be programmed in order to make the chip ready to operate at the correct frequency and mode. Due to the very fast start-up time, **CC2420** can remain in Power Down until a transmission session is requested.

As also described in the 4-wire Serial Configuration and Data Interface section on page 27, the crystal oscillator must be running (IDLE) in order to have access to the RAM and FIFOs.

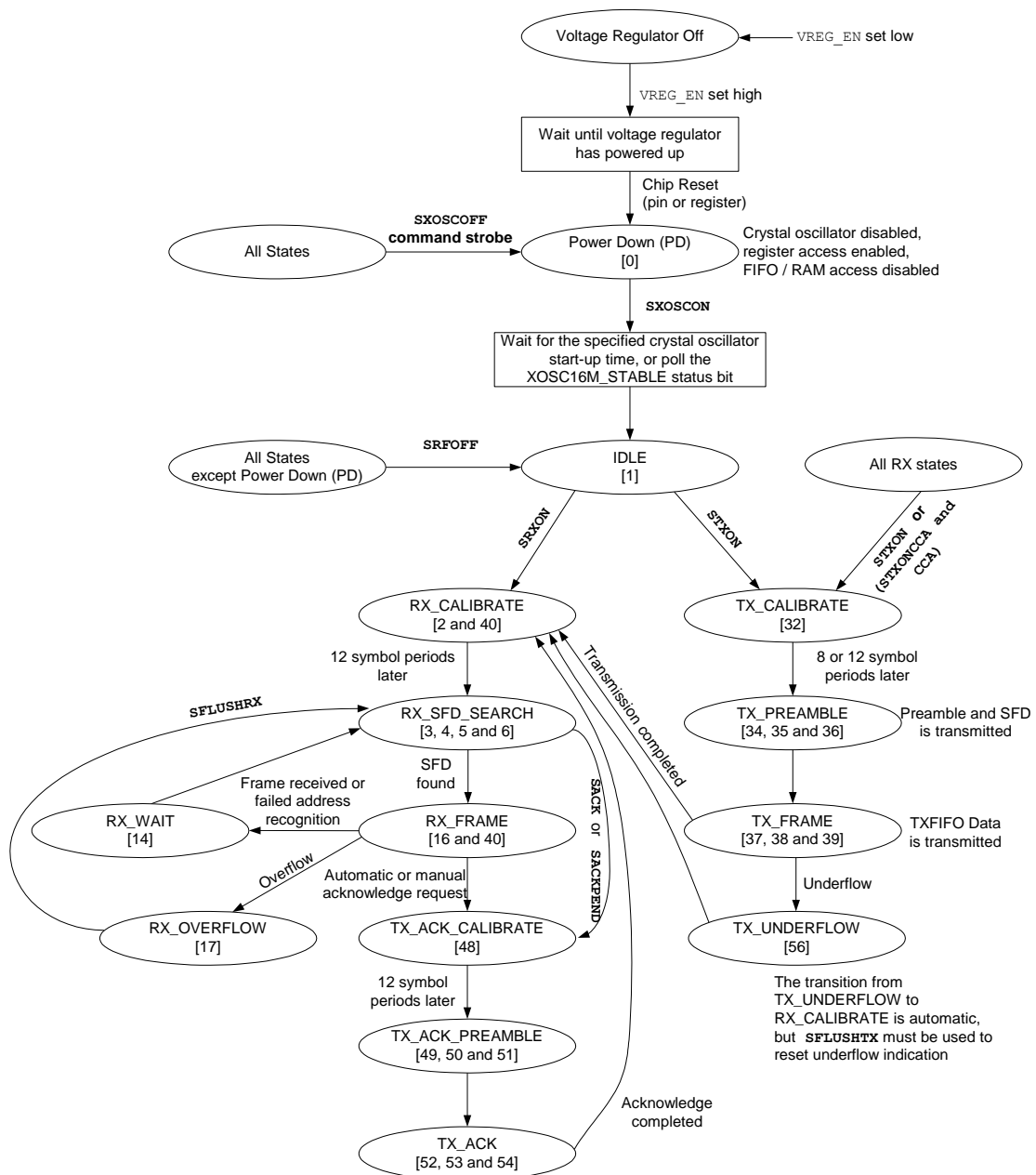

Figure 25. Radio control states

21 MAC Security Operations (Encryption and Authentication)

CC2420 features hardware IEEE 802.15.4 MAC security operations. This includes counter mode (CTR) encryption / decryption, CBC-MAC authentication and CCM encryption + authentication. All security operations are based on AES encryption [2] using 128 bit keys. Security operations are performed within the transmit and receive FIFOs on a frame basis.

CC2420 also includes stand-alone AES encryption, in which one 128 bit plaintext is encrypted to a 128 bit ciphertext.

The SAES, STXENC and SRXDEC command strobes are used to start security operations in **CC2420** as will be described in the following sections. The ENC_BUSY status bit (see Table 5) may be used to monitor when a security operation has been completed. Security command strobes issued while the security engine is busy will be ignored, and the ongoing operation will be completed.

Table 6 on page 31 shows the **CC2420** RAM memory map, including the security related data located from addresses 0x100 through 0x15F. RAM access (see the RAM access section on page 29) is used to write or read the keys, nonces and stand-alone buffer. All security related data is stored little-endian, i.e. the least significant byte is transferred first over the SPI interface during RAM read or write operations.

For a complete description of IEEE 802.15.4 MAC security operations, please refer to [1].

21.1 Keys

All security operations are based on 128 bit keys. The **CC2420** RAM space has storage space for two individual keys (KEY0 and KEY1). Transmit, receive and stand-alone encryption may select one of these two keys individually in the SEC_TXKEYSEL, SEC_RXKEYSEL and SEC_SAKEYSEL control bits (SECCTRL0).

As can be seen from Table 6 on page 31, KEY0 is located from address 0x100 and KEY1 from address 0x130.

A way of establishing the keys used for encryption and authentication must be decided for each particular application. IEEE 802.15.4 does not define how this is done, it is left to the higher layer of the protocol.

ZigBee uses an Elliptic Curve Cryptography (ECC) based approach to establish keys. For PC based solutions, more processor intensive solutions such as Diffie-Hellman may be chosen. Some applications may also use pre-programmed keys, e.g. for remote keyless entry where the key and lock are delivered in pairs. A push-button approach for loading keys may also be selected.

21.2 Nonce / counter

The receive and transmit nonces used for encryption / decryption are located in RAM from addresses 0x110 and 0x140 respectively. They are both 16 bytes.

The nonce must be correctly initialized before receive or transmit CTR or CCM operations are started. The format of the nonce is shown in Table 7. The block counter must be set to 1 for compliance with [1]. The key sequence counter is controlled by a layer above the MAC layer. The frame counter must be increased for each new frame by the MAC layer. The source address is the 64 bit IEEE address.

1 byte	8 bytes	4 bytes	1 byte	2 bytes
Flags	Source Address	Frame Counter	Key Sequence Counter	Block Counter

Table 7. IEEE 802.15.4 Nonce [1]

The block counter bytes are not updated in RAM, only in a local copy that is reloaded for each new in-line security operation. I.e. the block counter part of the nonce does not need to be rewritten. The **CC2420** block counter should be set to 0x0001 for compliance with [1].

CC2420 gives the user full flexibility in selecting the flags for both nonces. The flag setting is stored in the most significant byte of the nonce. The flag byte used for encryption and authentication is then generated as shown in Figure 26.

The frame counter part of the nonce must be incremented for each new packet by software.

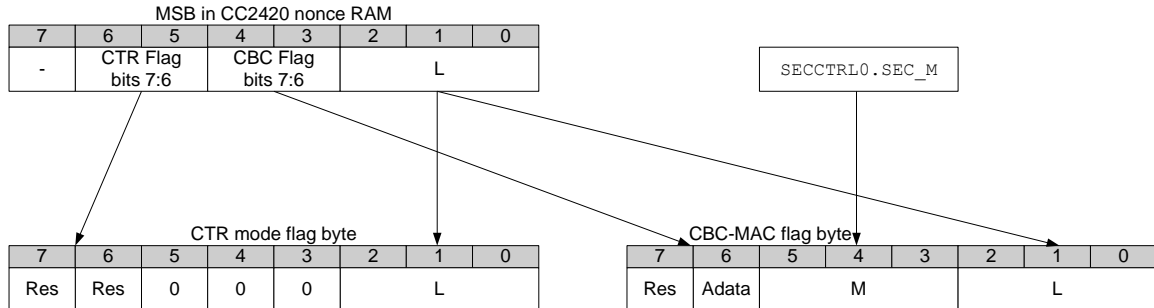

Figure 26. **CC2420** Security Flag Byte

21.3 Stand-alone encryption

Plain AES encryption, with 128 bit plaintext and 128 bit keys [2], is available using stand-alone encryption. The plaintext is stored in stand-alone buffer located at RAM location 0x120, as can be seen from Table 6 on page 31.

A stand-alone encryption operation is initiated by using the SAES command strobe. The selected key (`SECCTRL0.SEC_SKEYSEL`) is then used to encrypt the plaintext written to the stand-alone buffer. Upon completion of the encryption operation, the ciphertext is written back to the stand-alone buffer, thereby overwriting the plaintext.

Note that RAM write operations also output data currently in RAM, so that a new plaintext may be written at the same time as reading out the previous ciphertext.

21.4 In-line security operations

CC2420 can do MAC security operations (encryption, decryption and authentication) on frames within the TXFIFO and RXFIFO. These operations are called in-line security operations.

As with other MAC hardware support within **CC2420**, in-line security operation relies on the length field in the PHY header. A correct length field must

therefore be used for all security operations.

The key, nonce (does not apply to CBC-MAC), and `SECCTRL0` and `SECCTRL1` control registers must be correctly set before starting any in-line security operation.

The in-line security mode is set in `SECCTRL0.SEC_MODE` to one of the following modes:

- Disabled
- CBC-MAC (authentication)
- CTR (encryption / decryption)
- CCM (authentication and encryption / decryption)

When enabled, TX in-line security is started in one of two ways:

- Issue a `STXENC` command strobe. In-line security will be performed within the TXFIFO, but a RF transmission will not be started. Ciphertext may be read back using RAM read operations.
- Issue a `STXON` or `STXONCCA` command strobe. In-line security will be performed within the TXFIFO and a RF transmission of the ciphertext is started.

When enabled, RX in-line security is started as follows:

- Issue a `SRXDEC` command strobe. The first frame in the RXFIFO is then decrypted / authenticated as set by the current security mode.

RX in-line security operations are always performed on the first frame currently inside the RXFIFO, even if parts of this have already been read out over the SPI interface. This allows the receiver to first read the source address out to decide which key to use before doing authentication of the complete frame. In CTR or CCM mode it is of course important that bytes to be decrypted are not read out before the security operation is started.

When the `SRXDEC` command strobe is issued, the `FIFO` and `FIFOP` pins will go inactive. This is to indicate to the microcontroller that no further data may be read out before the next byte to be read has undergone the requested security operation.

The frame in the RXFIFO may be received over RF or it may be written into the RXFIFO over the SPI interface for debugging or higher layer security operations.

21.5 CTR mode encryption / decryption

CTR mode encryption / decryption is performed by **CC2420** on MAC frames within the TXFIFO / RXFIFO respectively.

`SECCTRL1.SEC_TXL / SEC_RXL` sets the number of bytes between the length field and the first byte to be encrypted / decrypted respectively. This controls the number of plaintext bytes in the current frame. For IEEE 802.15.4 MAC encryption, only the MAC payload (see Figure 17 on page 36) should be encrypted, so `SEC_TXL / SEC_RXL` is set to 3 + (0 to 20) depending on the address information in the current frame.

When encryption is initiated, the plaintext in the TXFIFO is then encrypted as specified by [1]. The encryption module will encrypt all the plaintext currently available, and wait if not everything is pre-buffered. The encryption operation may also be started without any data in the

TXFIFO at all, and data will be encrypted as it is written to the TXFIFO.

When decryption is initiated with a `SRXDEC` command strobe, the ciphertext of the RXFIFO is then decrypted as specified by [1].

21.6 CBC-MAC

CBC-MAC in-line authentication is provided by **CC2420** hardware.

`SECCTRL0.SEC_M` sets the MIC length M, encoded as $(M-2)/2$.

When enabling CBC-MAC in-line TXFIFO authentication, the generated MIC is written to the TXFIFO for transmission. The frame length must include the MIC.

`SECCTRL1.SEC_TXL / SEC_RXL` sets the number of bytes between the length field and the first byte to be authenticated, normally set to 0 for MAC authentication.

`SECCTRL0.SEC_CBC_HEAD` defines if the authentication length is used as the first byte of data to be authenticated or not. This bit should be set for compliance with [1].

When enabling CBC-MAC in-line RXFIFO authentication, the generated MIC is compared to the MIC in the RXFIFO. The last byte of the MIC is replaced in the RXFIFO with:

- 0x00 if the MIC is correct
- 0xFF if the MIC is incorrect

The other bytes in the MIC are left unchanged in the RXFIFO.

21.7 CCM

CCM combines CTR mode encryption and CBC-MAC authentication in one operation. CCM is described in [3].

`SECCTRL1.SEC_TXL / SEC_RXL` sets the number of bytes after the length field to be authenticated but not encrypted.

The MIC is generated and verified very much like with CBC-MAC described

above. The only differences are from the requirements in [1] for CCM.

21.8 Timing

Table 8 shows some examples of the time used by the security module for different operations.

Mode	I(a)	I(m)	I(MIC)	Time [us]
CCM	50	69	8	222
CTR	-	15	-	99
CBC	17	98	12	99
Stand-alone	-	16	-	14

Table 8. Security timing examples

22 Linear IF and AGC Settings

CC2420 is based on a linear IF chain where the signal amplification is done in an analog VGA (variable gain amplifier). The gain of the VGA is digitally controlled.

The AGC (Automatic Gain Control) loop ensures that the ADC operates inside its dynamic range by using an analog/digital feedback loop.

The AGC characteristics are set through the `AGCTRL`, `AGCTST0`, `AGCTST1` and `AGCTST2` registers. The reset values should be used for all AGC control and test registers.

23 RSSI / Energy Detection

CC2420 has a built-in RSSI (Received Signal Strength Indicator) providing a digital value that can be read from the 8 bit, signed 2's complement `RSSI.RSSI_VAL` register.

The RSSI value is always averaged over 8 symbol periods (128 μ s), in accordance with [1]. The `RSSI_VALID` status bit (Table 5) indicates when the RSSI value is valid, meaning that the receiver has been enabled for at least 8 symbol periods.

The RSSI register value `RSSI.RSSI_VAL` can be referred to the power P at the RF pins by using the following equations:

$$P = \text{RSSI_VAL} + \text{RSSI_OFFSET} \text{ [dBm]}$$

where the `RSSI_OFFSET` is found empirically during system development from the front end gain. `RSSI_OFFSET` is approximately -45 . E.g. if reading a value of -20 from the `RSSI` register, the RF input power is approximately -65 dBm.

A typical plot of the `RSSI_VAL` reading as function of input power is shown in Figure 27. It can be seen from the figure that the RSSI reading from **CC2420** is very linear and has a dynamic range of about 100 dB.

The RSSI register value `RSSI.RSSI_VAL` is calculated and continuously updated for each symbol after RSSI has become valid.

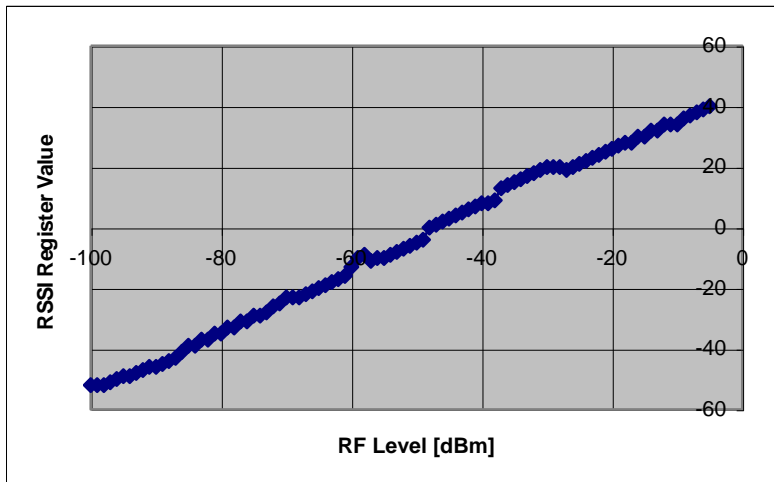

Figure 27. Typical RSSI value vs. input power

24 Link Quality Indication

The link quality indication (LQI) measurement is a characterisation of the strength and/or quality of a received packet, as defined by [1].

The RSSI value described in the previous section may be used by the MAC software to produce the LQI value. The LQI value is required by [1] to be limited to the range 0 through 255, with at least 8 unique values. Software is responsible for generating the appropriate scaling of the LQI value for the given application.

Using the RSSI value directly to calculate the LQI value has the disadvantage that e.g. a narrowband interferer inside the channel bandwidth will increase the LQI value although it actually reduces the true link quality. **CC2420** therefore also provides an average correlation value for each incoming packet, based on the 8 first symbols following the SFD. This unsigned 7-bit value can be looked upon as a measurement of the “chip error rate,” although **CC2420** does not do chip decision.

As described in the Frame check sequence section on page 38, the average correlation value for the 8 first symbols is appended to each received frame together with the RSSI and CRC OK/not OK when `MDMCTRL0.AUTOCRC` is set. A correlation value of ~110 indicates a maximum quality frame while a value of ~50 is typically the lowest quality frames detectable by **CC2420**.

Software must convert the correlation value to the range 0-255 defined by [1], e.g. by calculating:

$$LQI = (CORR - a) \cdot b$$

limited to the range 0-255, where *a* and *b* are found empirically based on PER measurements as a function of the correlation value.

A combination of RSSI and correlation values may also be used to generate the LQI value.

25 Clear Channel Assessment

The clear channel assessment signal is based on the measured RSSI value and a programmable threshold. The clear channel assessment function is used to implement the CSMA-CA functionality specified in [1]. CCA is valid when the receiver has been enabled for at least 8 symbol periods.

Carrier sense threshold level is programmed by `RSSI.CCA_THR`. The threshold value can be programmed in steps of 1 dB. A CCA hysteresis can also be programmed in the `MDMCTRL0.CCA_HYST` control bits.

All 3 CCA modes specified by [1] are implemented in **CC2420**. They are set in `MDMCTRL0.CCA_MODE`, as can be seen in the register description. The different modes are:

- 0 Reserved
- 1 Clear channel when received energy is below threshold.
- 2 Clear channel when not receiving valid IEEE 802.15.4 data.
- 3 Clear channel when energy is below threshold and not receiving valid IEEE 802.15.4 data

Clear channel assessment is available on the CCA output pin. CCA is active high, but the polarity may be changed by setting the `IOCFG0.CCA_POLARITY` control bit.

Implementing CSMA-CA may easiest be done by using the `STXONCCA` command strobe, as described in the Radio control state machine section on page 43. Transmission will then only start if the channel is clear. The `TX_ACTIVE` status bit (see Table 5) may be used to detect the result of the CCA.

26 Frequency and Channel Programming

The operating frequency is set by programming the 10 bit frequency word located in `FSCTRL.FREQ[9:0]`. The operating frequency F_C in MHz is given by:

$$F_C = 2048 + \text{FSCTRL.FREQ}[9:0] \text{ MHz}$$

The frequency can be programmed with 1 MHz resolution. In receive mode the actual LO frequency is $F_C - 2$ MHz, since a 2 MHz IF is used. Direct conversion is used for transmission, so here the LO frequency equals F_C . The 2 MHz IF is automatically set by **CC2420**, so the frequency programming is equal for RX and TX.

IEEE 802.15.4 specifies 16 channels within the 2.4 GHz band, in 5 MHz steps, numbered 11 through 26. The RF frequency of channel k is given by [1]:

$$F_C = 2405 + 5(k-11) \text{ MHz}, k=11, 12, \dots, 26$$

For operation in channel k, the `FSCTRL.FREQ` register should therefore be set to:

$$\text{FSCTRL.FREQ} = 357 + 5(k-11)$$

27 VCO and PLL Self-Calibration

27.1 VCO

The VCO is completely integrated and operates at 4800 – 4966 MHz. The VCO frequency is divided by 2 to generate frequencies in the desired band (2400-2483.5 MHz).

In order to ensure reliable operation the VCO's bias current and tuning range are automatically calibrated every time the RX mode or TX mode is enabled, i.e. in the RX_CALIBRATE, TX_CALIBRATE and TX_ACK_CALIBRATE control states in Figure 25 on page 44.

27.2 PLL self-calibration

The VCO's characteristics will vary with temperature, changes in supply voltages, and the desired operating frequency.

28 Output Power Programming

The RF output power of the device is programmable and is controlled by the TXCTRL.PA_LEVEL register. Table 9 shows the output power for different

settings, including the complete programming of the TXCTRL control register. The typical current consumption is also shown.

PA_LEVEL	TXCTRL register	Output Power [dBm]	Current Consumption [mA]
31	0xA0FF	0	17.4
27	0xA0FB	-1	16.5
23	0xA0F7	-3	15.2
19	0xA0F3	-5	13.9
15	0xA0EF	-7	12.5
11	0xA0EB	-10	11.2
7	0xA0E7	-15	9.9
3	0xA0E3	-25	8.5

Table 9. Output power settings and typical current consumption @ 2.45 GHz

29 Voltage Regulator

CC2420 includes a low drop-out voltage regulator. This is used to provide a 1.8 V power supply to the **CC2420** power supplies. The voltage regulator should not be used to provide power to other circuits because of limited power sourcing capability and noise considerations.

The regulated 1.8 V voltage output is available on the VREG_OUT pin. A simplified schematic of the voltage regulator is shown in Figure 28.

The voltage regulator input pin VREG_IN is connected to the unregulated 2.1 to 3.6 V power supply. The voltage regulator is enabled / disabled using the active high voltage regulator enable pin VREG_EN.

The voltage regulator requires external components as described in the Application Circuit section on page 19.

When disabling the voltage regulator, note that register and RAM programming will be lost as leakage current reduces the output voltage on the VREG_OUT pin below 1.6 V.

CC2420 should then be reset before the voltage regulator is disabled.

In applications where the internal voltage regulator is not used, connect `VREG_EN` and `VREG_IN` to ground. `VREG_OUT` shall

be left open. Note that the battery monitor will not work when the voltage regulator is not used.

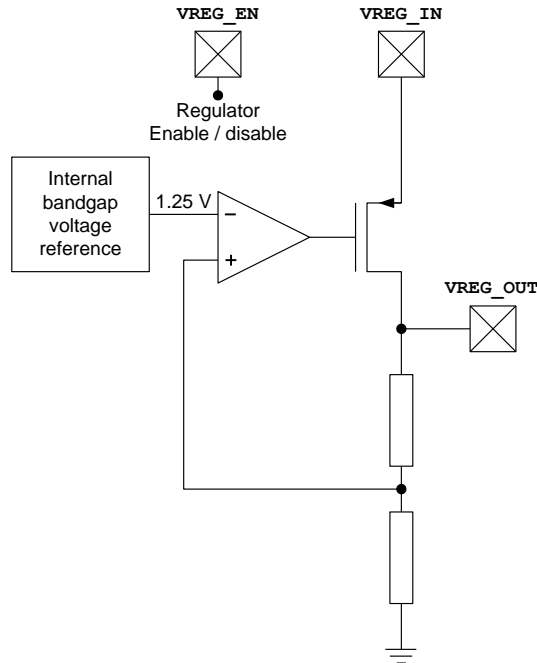

Figure 28. Voltage regulator, simplified schematic

30 Battery Monitor

The on-chip battery monitor enables monitoring the unregulated voltage on the `VREG_IN` pin. It gives status information on the voltage being above or below a

programmable threshold. A simplified schematic of the battery monitor is shown in Figure 29.

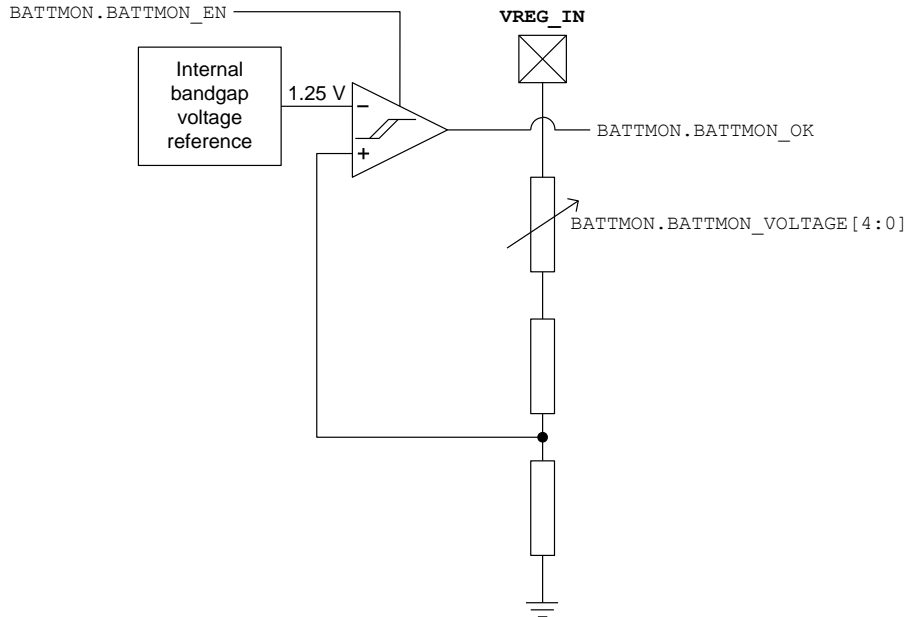

Figure 29. Battery monitor, simplified schematic

The battery monitor is controlled through the BATTMON control register. The battery monitor is enabled and disabled using the BATTMON.BATTMON_EN control bit. The voltage regulator must also be enabled when using the battery monitor.

The battery monitor status bit is available in the BATTMON.BATTMON_OK status bit. This bit is high when the VREG_IN input voltage is higher than the toggle voltage V_{toggle} .

The battery monitor toggle voltage is set in the 5-bit BATTMON.BATTMON_VOLTAGE control bits. BATTMON_VOLTAGE is an unsigned, positive number from 0 to 31. The toggle voltage is given by:

$$V_{toggle} = 1.25 \text{ V} \cdot \frac{72 - \text{BATTMON_VOLTAGE}}{27}$$

Alternatively, for a desired toggle voltage, BATTMON_VOLTAGE should be set according to:

$$\text{BATTMON_VOLTAGE} = 72 - 27 \cdot \frac{V_{toggle}}{1.25 \text{ V}}$$

The voltage regulator must be enabled for at least 100 μs before the first measurement. After being enabled, the BATTMON_OK status bit needs 2 μs to settle for each new toggle voltage programmed.

The main performance characteristics of the battery monitor is shown in the Electrical Specifications section on page 9.

31 Crystal Oscillator

An external clock signal or the internal crystal oscillator can be used as main frequency reference. The reference frequency must be 16 MHz. Because the crystal frequency is used as reference for the data rate as well as other internal signal processing functions, other frequencies cannot be used.

If an external clock signal is used this should be connected to XOSC16_Q1, while XOSC16_Q2 should be left open. The

MAIN.XOSC16M_BYPASS bit must be set when an external clock signal is used.

Using the internal crystal oscillator, the crystal must be connected between the XOSC16_Q1 and XOSC16_Q2 pins. The oscillator is designed for parallel mode operation of the crystal. In addition, loading capacitors (C_{381} and C_{391}) for the crystal are required. The loading capacitor values depend on the total load capacitance, C_L , specified for the crystal.

The total load capacitance seen between the crystal terminals should equal C_L for the crystal to oscillate at the specified frequency.

$$C_L = \frac{1}{\frac{1}{C_{381}} + \frac{1}{C_{391}}} + C_{parasitic}$$

The parasitic capacitance is constituted by pin input capacitance and PCB stray capacitance. The total parasitic capacitance is typically 2 pF - 5 pF.

The crystal oscillator circuit is shown in Figure 30. Typical component values for different values of C_L are given in Table 10.

The crystal oscillator is amplitude regulated. This means that a high current is used to start up the oscillations. When the amplitude builds up, the current is reduced to what is necessary to maintain a stable oscillation. This ensures a fast start-up and keeps the drive level to a minimum. The ESR of the crystal must be within the specification in order to ensure a reliable start-up (see the Electrical Specifications section).

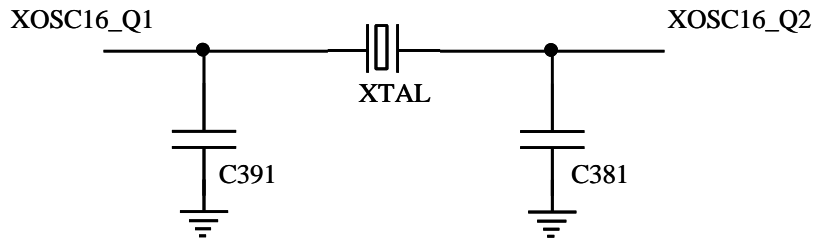

Figure 30. Crystal oscillator circuit

Item	$C_L = 16 \text{ pF}$
C381	27 pF
C391	27 pF

Table 10. Crystal oscillator component values

32 Input / Output Matching

The RF input / output is differential (RF_N and RF_P). In addition there is supply switch output pin ($TXRX_SWITCH$) that must have an external DC path to RF_N and RF_P .

In RX mode the $TXRX_SWITCH$ pin is at ground and will bias the LNA. In TX mode the $TXRX_SWITCH$ pin is at supply rail voltage and will properly bias the internal PA.

The RF output and DC bias can be done using different topologies. Some are shown in Figure 4 and Figure 5.

Component values are given in Table 2. Using a differential antenna, no balun is required.

If a single ended output is required (for a single ended connector or a single ended antenna), a balun should be used for optimum performance.

The balun adds the signals from the RF_N and RF_P . This is achieved having two paths with equal amplitude response, but 180 degrees phase difference.

33 Transmitter Test Modes

CC2420 can be set into different transmit test modes for performance evaluation. The test mode descriptions in the following sections requires that the chip is first reset, the crystal oscillator is enabled using the `SXOSCON` command strobe and that the crystal oscillator has stabilised.

`0x1800` to the `DACTST` register and issue a `STXON` command strobe. The transmitter is then enabled while the transmitter I/Q DACs are overridden to static values. An unmodulated carrier will then be available on the RF output pins.

A plot of the single carrier output spectrum from **CC2420** is shown in Figure 31 below.

33.1 Unmodulated carrier

An unmodulated carrier may be transmitted by setting `MDMCTRL1.TX_MODE` to 2 or 3, writing

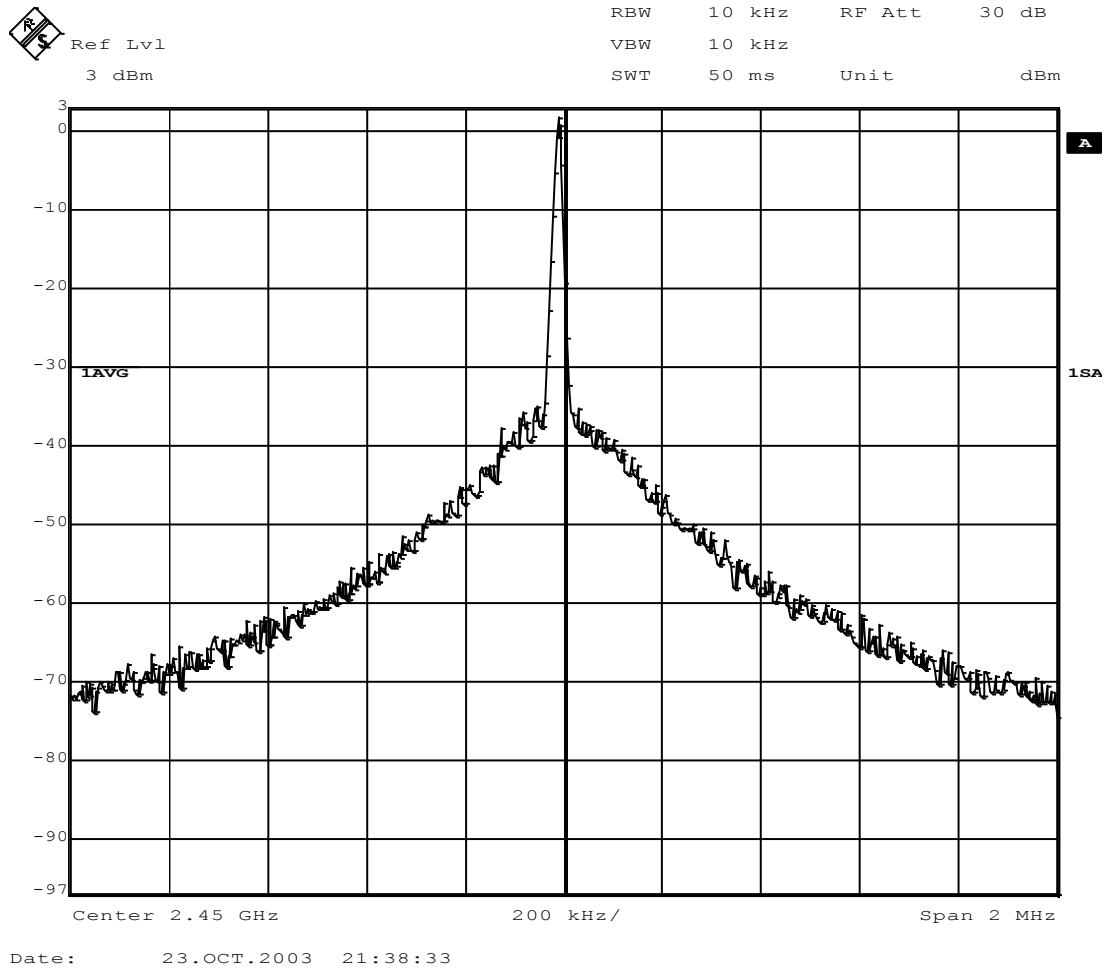

Figure 31. Single carrier output

33.2 Modulated spectrum

The **CC2420** has a built-in test pattern generator that can generate pseudo random sequence using the CRC generator. This is enabled by setting `MDMCTRL1.TX_MODE` to 3 and issues an `STXON` command strobe. The modulated spectrum is then available on the RF pins. The low byte of the CRC word is transmitted and the CRC is updated with 0xFF for each new byte. The length of the transmitted data sequence is 65535 bits. The transmitted data-sequence is then:

[Synchronisation header] [0x00, 0x78, 0xb8, 0x4b, 0x99, 0xc3, 0xe9, ...]

Since a synchronisation header (preamble and SFD) is transmitted in all TX modes, this test mode may also be used to transmit a known pseudorandom bit

sequence for bit error testing. Please note that **CC2420** requires symbol synchronisation, not only bit synchronisation, for correct reception. Packet error rate is therefore a better measurement for the true RF performance.

Another option to generate a modulated spectrum is to fill the TXFIFO with pseudo-random data and set `MDMCTRL1.TX_MODE` to 2. **CC2420** will then transmit data from the FIFO disregarding a TXFIFO underflow. The length of the transmitted data sequence is then 1024 bits (128 bytes).

A plot of the modulated spectrum from **CC2420** is shown in Figure 32. Note that to find the output power from the modulated spectrum, the RBW must be set to 3 MHz or higher.

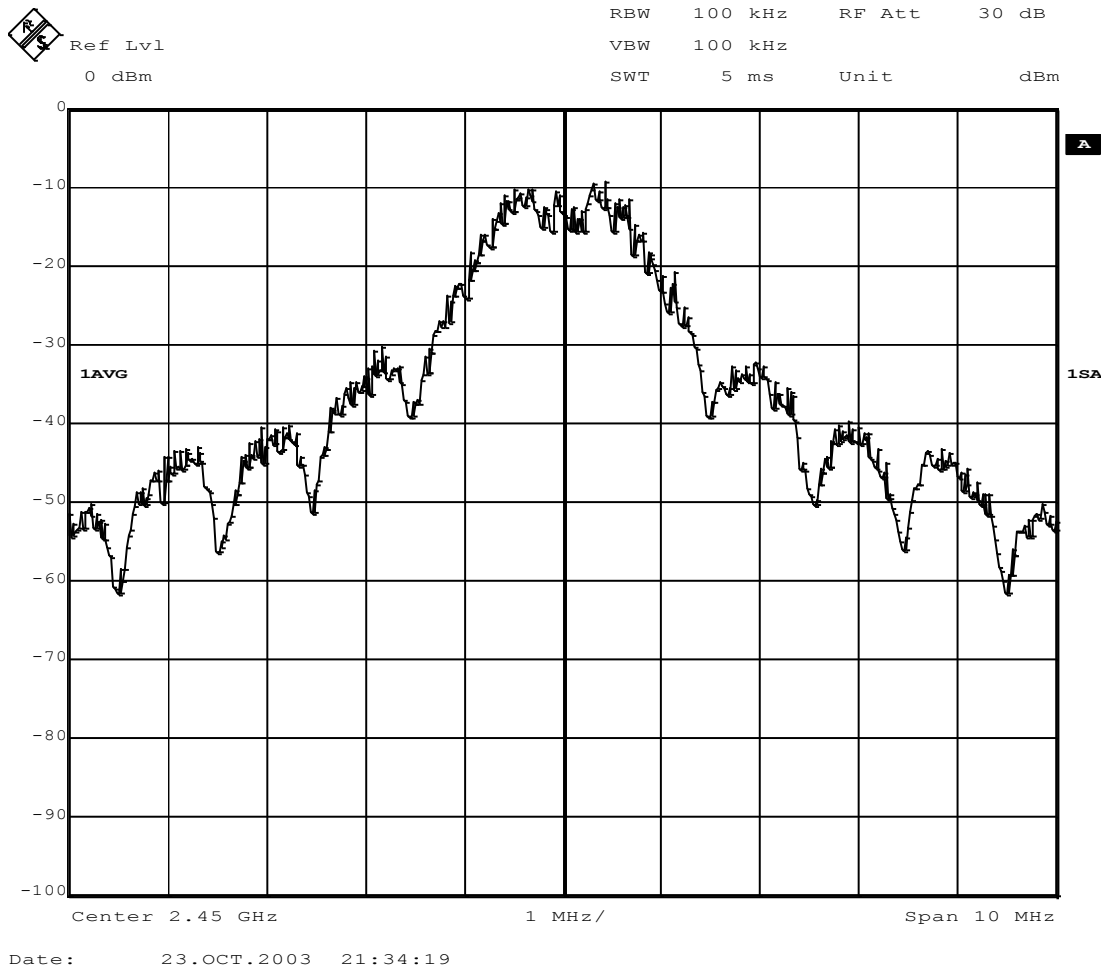

Figure 32. Modulated spectrum plot

34 System Considerations and Guidelines

SRD regulations

International regulations and national laws regulate the use of radio receivers and transmitters. SRDs (Short Range Devices) for license free operation are allowed to operate in the 2.4 GHz band worldwide. The most important regulations are ETSI EN 300 328 and EN 300 440 (Europe), FCC CFR-47 part 15.247 and 15.249 (USA), and ARIB STD-T66 (Japan).

34.1 Frequency hopping and multi-channel systems

The 2.4 GHz band is shared by many systems both in industrial, office and home environments. **CC2420** uses direct sequence spread spectrum (DSSS) as defined by [1] to spread the output power, thereby making the communication link more robust even in a noisy environment.

With **CC2420** it is also possible to combine both DSSS and FHSS (frequency hopping spread spectrum) in a proprietary non-IEEE 802.15.4 system. This is achieved by reprogramming the operating frequency (see the Frequency and Channel Programming section on page 50) before enabling RX or TX. A frequency synchronisation scheme must then be implemented within the proprietary MAC layer to make the transmitter and receiver operate on the same RF channel.

34.2 Data burst transmissions

The data buffering in **CC2420** lets the user have a lower data rate link between the microcontroller and the RF device than the RF bit rate of 250 kbps. This allows the microcontroller to buffer data at its own speed, reducing the workload and timing requirements.

The relatively high data rate of **CC2420** also reduces the average power consumption compared to the 868 / 915 MHz bands defined by [1], where only 20 / 40 kbps are available. **CC2420** may be powered up a smaller portion of the time, so that the average power consumption is reduced for a given amount of data to be transferred.

34.3 Crystal accuracy and drift

A crystal accuracy of ± 40 ppm is required for compliance with IEEE 802.15.4 [1]. This accuracy must also take ageing and temperature drift into consideration.

A crystal with low temperature drift and low aging could be used without further compensation. A trimmer capacitor in the crystal oscillator circuit (in parallel with C7) could be used to set the initial frequency accurately.

For non-IEEE 802.15.4 systems, the robust demodulator in **CC2420** allows up to 120 ppm total frequency offset between the transmitter and receiver. This could e.g. relax the accuracy requirement to 60 ppm for each of the devices.

Optionally in a star network topology, the FFD could be equipped with a more accurate crystal thereby relaxing the requirement on the RFD. This can make sense in systems where the RFDs ship in higher volumes than the FFDs.

34.4 Communication robustness

CC2420 provides very good adjacent, alternate and co channel rejection, image frequency suppression and blocking properties. The **CC2420** performance is significantly better than the requirements imposed by [1]. These are highly important parameters for reliable operation in the 2.4 GHz band, since an increasing number of devices/systems are using this license free frequency band.

34.5 Communication security

The hardware encryption and authentication operations in **CC2420** enable secure communication, which is required for many applications. Security operations require a lot of data processing, which is costly in an 8-bit microcontroller system. The hardware support within **CC2420** enables a high level of security even with a low-cost 8 bit controller.

34.6 Low-cost systems

As the **CC2420** provides 250 kbps multi-channel performance without any external filters, a very low-cost system can be made.

A differential antenna will eliminate the need for a balun, and the DC biasing can be achieved in the antenna topology.

34.7 Battery operated systems

In low power applications, the **CC2420** should be powered down when not being active. Extremely low power consumption may be achieved when disabling also the voltage regulator. This will require reprogramming of the register and RAM configuration.

34.8 BER / PER measurements

CC2420 includes test modes where data is received infinitely and output to pins (RX_MODE 2, see page 40). This mode may be used for Bit Error Rate (BER) measurements. However, the following actions must be taken to do such a measurement:

- A preamble and SFD sequence must be used, even if pseudo random data is transmitted, since receiving the DSSS modulated signal requires *symbol* synchronisation, not *bit* synchronisation like e.g. in 2FSK systems. The SYNCWORD may be set to another value to fit to the measurement setup if necessary.
- The data transmitted over air must be spread according to [1] and the description on page 24. This means that the transmitter used during measurements must be able to do spreading of the bit data to chip data. Remember that the *chip* sequence transmitted by the test setup is not the same as the *bit* sequence, which is output by **CC2420**.
- When operating at or below the sensitivity limit, **CC2420** may lose symbol synchronisation in infinite receive mode. A new SFD and restart of the receiver may be

required to re-gain synchronisation.

In an IEEE 802.15.4 system, all communication is based on packets. The sensitivity limit specified by [1] is based on Packet Error Rate (PER) measurements instead of BER. This is a more accurate measurement of the true RF performance since it mirrors the way the actual system operates.

It is recommended to perform PER measurements instead of BER measurements to evaluate the performance of IEEE 802.15.4 systems. To do PER measurements, the following may be used as a guideline:

- A valid preamble, SFD and length field must be used for each packet.
- The PSDU (see Figure 17 on page 36) length should be 20 bytes for sensitivity measurements as specified by [1].
- The sensitivity limit specified by [1] is the RF level resulting in a 1% PER. The packet sample space for a given measurement must then be $\gg 100$ to have a sufficiently large sample space. E.g. at least 1000 packets should be used to measure the sensitivity.
- The data transmitted over air must be spread according to [1] and the description on page 24. Pre-generated packets may be used, although [1] requires that the PER is averaged over random PSDU data.
- The **CC2420** receive FIFO may be used to buffer data received during PER measurements, since it is able to buffer up to 128 bytes.
- The MDMCTRL1.CORR_THR control register is by default set to 20, as described in the Demodulator, Symbol Synchroniser and Data Decision section.

- The `RXCTRL1.RXBPF_LOCUR` control bit should be set to 1.

The simplest way of making a PER measurement will be to use another **CC2420** as the reference transmitter. However, this makes it difficult to measure the exact receiver performance.

Using a signal generator, this may either be set up as O-QPSK with half-sine shaping or as MSK. If using O-QPSK, the phases must be selected according to [1]. If using MSK, the chip sequence must be modified such that the modulated MSK

signal has the same phase shifts as the O-QPSK sequence previously defined.

For a desired symbol sequence s_0, s_1, \dots, s_{n-1} of length n symbols, the desired chip sequence $c_0, c_1, c_2, \dots, c_{32n-1}$ of length $32n$ is found using table lookup from Table 3 on page 24. It can be seen from comparing the phase shifts of the O-QPSK signal with the frequency of a MSK signal that the MSK chip sequence is generated as:

$(c_0 \text{ XOR } c_1), (c_1 \text{ XOR } c_2), (c_2 \text{ XOR } c_3), \dots, (c_{32n-1} \text{ XOR } c_{32n})$ where c_{32n} may be arbitrarily selected.

35 PCB Layout Recommendations

Following Texas Instruments's reference design is highly recommended.

In our reference design, the top layer is used for signal routing, and the open areas are filled with metallisation connected to ground using several vias. Layer 2 has not been used in our CC2420 reference designs. Layer 3 is used for power routing and the bottom layer serves as ground plane with a little routing.

The area under the chip is used for grounding and must be well connected to the ground plane with several vias.

The ground pins should be connected to ground as close as possible to the package pin using individual vias. The decoupling capacitors should also be placed as close as possible to the supply pins and connected to the ground plane by separate

vias. Supply power filtering is very important.

The external components should be as small as possible (0402 is recommended) and surface mount devices must be used.

Caution should be used when placing the microcontroller in order to avoid interference with the RF circuitry.

A Development Kit with a fully assembled Evaluation Module is available. It is strongly advised that this reference layout is followed very closely in order to get the best performance.

The schematic, BOM and layout Gerber files for the reference designs are all available from the Texas Instruments website.

36 Antenna Considerations

CC2420 can be used together with various types of antennas. A differential antenna like a dipole would be the easiest to interface not needing a balun (balanced to un-balanced transformation network).

The length of the $\lambda/2$ -dipole antenna is given by:

$$L = 14250 / f$$

where f is in MHz, giving the length in cm. An antenna for 2450 MHz should be 5.8 cm. Each arm is therefore 2.9 cm.

Other commonly used antennas for short-range communication are monopole, helical and loop antennas. The single-ended monopole and helical would require a balun network between the differential output and the antenna.

Monopole antennas are resonant antennas with a length corresponding to one quarter of the electrical wavelength ($\lambda/4$). They are very easy to design and can be implemented simply as a "piece of wire" or even integrated into the PCB.

The length of the $\lambda/4$ -monopole antenna is given by:

$$L = 7125 / f$$

where f is in MHz, giving the length in cm. An antenna for 2450 MHz should be 2.9 cm.

Non-resonant monopole antennas shorter than $\lambda/4$ can also be used, but at the expense of range. In size and cost critical applications such an antenna may very well be integrated into the PCB.

Enclosing the antenna in high dielectric constant material reduces the overall size of the antenna. Many vendors offer such antennas intended for PCB mounting.

Helical antennas can be thought of as a combination of a monopole and a loop antenna. They are a good compromise in size critical applications. Helical antennas tend to be more difficult to optimize than the simple monopole.

Loop antennas are easy to integrate into the PCB, but are less effective due to difficult impedance matching because of their very low radiation resistance.

For low power applications the differential antenna is recommended giving the best range and because of its simplicity.

The antenna should be connected as close as possible to the IC. If the antenna is located away from the RF pins the antenna should be matched to the feeding transmission line (50 Ω).

37 Configuration Registers

The configuration of **CC2420** is done by programming the 16-bit configuration registers. Complete descriptions of the registers are given in the following tables. After chip reset (from the `RESETn` pin or programmable through the `MAIN.RESETn` configuration bit), all the registers have default values as shown in the tables.

Note that the `MAIN` register is only reset by using the pin reset `RESETn`. When writing to this register, all bits will get the value written, not the default value. This also means that the `MAIN.RESETn` bit must be written both low and then high to perform a chip reset through the serial interface.

15 registers are Strobe Command Registers, listed first in Table 11 below. Accessing these registers will initiate the change of an internal state or mode. There are 33 normal 16-bits registers, also listed

in Table 11. Many of these registers are for test purposes only, and need not be accessed for normal operation of **CC2420**.

The FIFOs are accessed through two 8-bit registers, `TXFIFO` and `RXFIFO`. The `TXFIFO` register is write only. Data may still be read out of the `TXFIFO` through regular RAM access (see section RAM access section on page 29), but data is then not removed from the FIFO. Note that the crystal oscillator must be active for all FIFO and RAM access.

During address transfer, and while data is being written to the `TXFIFO`, a status byte is returned on the serial data output pin `SO`. This status byte is described in Table 5 on page 29.

All configuration and status registers are described in the tables following Table 11.

Address	Register	Register type	Description
0x00	SNOP	S	No Operation (has no other effect than reading out status-bits)
0x01	SXOSCON	S	Turn on the crystal oscillator (set <code>XOSC16M_PD = 0</code> and <code>BIAS_PD = 0</code>)
0x02	STXCAL	S	Enable and calibrate frequency synthesizer for TX; Go from RX / TX to a wait state where only the synthesizer is running.
0x03	SRXON	S	Enable RX
0x04	STXON	S	Enable TX after calibration (if not already performed) Start TX in-line encryption if <code>SPI_SEC_MODE ≠ 0</code>
0x05	STXONCCA	S	If CCA indicates a clear channel: Enable calibration, then TX. Start in-line encryption if <code>SPI_SEC_MODE ≠ 0</code> else do nothing
0x06	SRFOFF	S	Disable RX/TX and frequency synthesizer
0x07	SXOSCOFF	S	Turn off the crystal oscillator and RF
0x08	SFLUSHRX	S	Flush the RX FIFO buffer and reset the demodulator. Always read at least one byte from the <code>RXFIFO</code> before issuing the <code>SFLUSHRX</code> command strobe
0x09	SFLUSHTX	S	Flush the TX FIFO buffer
0x0A	SACK	S	Send acknowledge frame, with pending field cleared.
0x0B	SACKPEND	S	Send acknowledge frame, with pending field set.
0x0C	SRXDEC	S	Start <code>RXFIFO</code> in-line decryption / authentication (as set by <code>SPI_SEC_MODE</code>)
0x0D	STXENC	S	Start <code>TXFIFO</code> in-line encryption / authentication (as set by <code>SPI_SEC_MODE</code>), without starting TX.

Address	Register	Register type	Description
0x0E	SAES	S	AES Stand alone encryption strobe. SPI_SEC_MODE is not required to be 0, but the encryption module must be idle. If not, the strobe is ignored.
0x0F	-	-	Not used
0x10	MAIN	R/W	Main Control Register
0x11	MDMCTRL0	R/W	Modem Control Register 0
0x12	MDMCTRL1	R/W	Modem Control Register 1
0x13	RSSI	R/W	RSSI and CCA Status and Control register
0x14	SYNCWORD	R/W	Synchronisation word control register
0x15	TXCTRL	R/W	Transmit Control Register
0x16	RXCTRL0	R/W	Receive Control Register 0
0x17	RXCTRL1	R/W	Receive Control Register 1
0x18	FSCTRL	R/W	Frequency Synthesizer Control and Status Register
0x19	SECCTRL0	R/W	Security Control Register 0
0x1A	SECCTRL1	R/W	Security Control Register 1
0x1B	BATTMON	R/W	Battery Monitor Control and Status Register
0x1C	IOCFG0	R/W	Input / Output Control Register 0
0x1D	IOCFG1	R/W	Input / Output Control Register 1
0x1E	MANFIDL	R/W	Manufacturer ID, Low 16 bits
0x1F	MANFIDH	R/W	Manufacturer ID, High 16 bits
0x20	FSMTC	R/W	Finite State Machine Time Constants
0x21	MANAND	R/W	Manual signal AND override register
0x22	MANOR	R/W	Manual signal OR override register
0x23	AGCCTRL	R/W	AGC Control Register
0x24	AGCTST0	R/W	AGC Test Register 0
0x25	AGCTST1	R/W	AGC Test Register 1
0x26	AGCTST2	R/W	AGC Test Register 2
0x27	FSTST0	R/W	Frequency Synthesizer Test Register 0
0x28	FSTST1	R/W	Frequency Synthesizer Test Register 1
0x29	FSTST2	R/W	Frequency Synthesizer Test Register 2
0x2A	FSTST3	R/W	Frequency Synthesizer Test Register 3
0x2B	RXBPFSTST	R/W	Receiver Bandpass Filter Test Register
0x2C	FSMSTATE	R	Finite State Machine State Status Register
0x2D	ADCTST	R/W	ADC Test Register
0x2E	DACTST	R/W	DAC Test Register
0x2F	TOPTST	R/W	Top Level Test Register
0x30	RESERVED	R/W	Reserved for future use control / status register
0x31-0x3D	-	-	Not used
0x3E	TXFIFO	W	Transmit FIFO Byte Register
0x3F	RXFIFO	R/W	Receiver FIFO Byte Register

R/W - Read/write (control/status), R - Read only, W – Write only, S – Command Strobe (perform action upon access)

Table 11. Configuration registers overview

MAIN (0x10) - Main Control Register

Bit	Field Name	Reset	R/W	Description
15	RESETn	1	R/W	Active low reset of the entire circuit should be applied before doing anything else. Equivalent to using the RESETn reset pin.
14	ENC_RESETn	1	R/W	Active low reset of the encryption module. (Test purposes only)
13	DEMOD_RESETn	1	R/W	Active low reset of the demodulator module. (Test purposes only)
12	MOD_RESETn	1	R/W	Active low reset of the modulator module. (Test purposes only)
11	FS_RESETn	1	R/W	Active low reset of the frequency synthesizer module. (Test purposes only)
10:1	-	0	W0	Reserved, write as 0
0	XOSC16M_BYPASS	0	R/W	Bypasses the crystal oscillator and uses a buffered version of the signal on Q1 directly. This can be used to apply an external rail-rail clock signal to the Q1 pin.

MDMCTRL0 (0x11) - Modem Control Register 0

Bit	Field Name	Reset	R/W	Description
15:14	–	0	W0	Reserved, write as 0
13	RESERVED_FRAME_MODE	0	R/W	Mode for accepting reserved IEEE 802.15.4 frame types when address recognition is enabled (MDMCTRL0.ADR_DECODE = 1). 0 : Reserved frame types (100, 101, 110, 111) are rejected by address recognition. 1 : Reserved frame types (100, 101, 110, 111) are always accepted by address recognition. No further address decoding is done. When address recognition is disabled (MDMCTRL0.ADR_DECODE = 0), all frames are received and RESERVED_FRAME_MODE is don't care.
12	PAN_COORDINATOR	0	R/W	Should be set high when the device is a PAN Coordinator. Used for filtering packets with no destination address, as specified in section 7.5.6.2 in 802.15.4, D18
11	ADR_DECODE	1	R/W	Hardware Address decode enable. 0 : Address decoding is disabled 1 : Address decoding is enabled
10:8	CCA_HYST [2:0]	2	R/W	CCA Hysteresis in dB, values 0 through 7 dB
7:6	CCA_MODE [1:0]	3	R/W	0 : Reserved 1 : CCA=1 when RSSI_VAL < CCA_THR - CCA_HYST CCA=0 when RSSI_VAL ≥ CCA_THR 2 : CCA=1 when not receiving valid IEEE 802.15.4 data, CCA=0 otherwise 3 : CCA=1 when RSSI_VAL < CCA_THR - CCA_HYST and not receiving valid IEEE 802.15.4 data. CCA=0 when RSSI_VAL ≥ CCA_THR or receiving a packet
5	AUTOCRC	1	R/W	In packet mode a CRC-16 (ITU-T) is calculated and is transmitted after the last data byte in TX. In RX CRC is calculated and checked for validity.
4	AUTOACK	0	R/W	If AUTOACK is set, all packets accepted by address recognition with the acknowledge request flag set and a valid CRC are acknowledged 12 symbol periods after being received.
3:0	PREAMBLE_LENGTH [3:0]	2	R/W	The number of preamble bytes (2 zero-symbols) to be sent in TX mode prior to the SYNCWORD, encoded in steps of 2. The reset value of 2 is compliant with IEEE 802.15.4, since the 4 th zero byte is included in the SYNCWORD. 0 : 1 leading zero bytes (not recommended) 1 : 2 leading zero bytes (not recommended) 2 : 3 leading zero bytes (IEEE 802.15.4 compliant) 3 : 4 leading zero bytes ... 15 : 16 leading zero bytes

MDMCTRL1 (0x12)– Modem Control Register 1

Bit	Field Name	Reset	R/W	Description
15:11	–	0	W0	Reserved, write as 0.
10:6	CORR_THR[4:0]	20	R/W	Demodulator correlator threshold value, required before SFD search. Note that on early CC2420 versions the reset value was 0.
5	DEMOD_AVG_MODE	0	R/W	Frequency offset average filter behaviour. 0 : Lock frequency offset filter after preamble match 1 : Continuously update frequency offset filter.
4	MODULATION_MODE	0	R/W	Set one of two RF modulation modes for RX / TX 0 : IEEE 802.15.4 compliant mode 1 : Reversed phase, non-IEEE compliant (could be used to set up a system which will not receive 802.15.4 packets)
3:2	TX_MODE[1:0]	0	R/W	Set test modes for TX 0 : Buffered mode, use TXFIFO (normal operation) 1 : Serial mode, use transmit data on serial interface, infinite transmission. For lab testing only. 2 : TXFIFO looping ignore underflow in TXFIFO and read cyclic, infinite transmission. For lab testing only. 3 : Send random data from CRC, infinite transmission. For lab testing only.
1:0	RX_MODE[1:0]	0	R/W	Set test mode of RX 0 : Buffered mode, use RXFIFO (normal operation) 1 : Receive serial mode, output received data on pins. Infinite RX. For lab testing only. 2 : RXFIFO looping ignore overflow in RXFIFO and write cyclic, infinite reception. For lab testing only. 3 : Reserved

RSSI (0x13) - RSSI and CCA Status and Control Register

Bit	Field Name	Reset	R/W	Description
15:8	CCA_THR[7:0]	-32	R/W	Clear Channel Assessment threshold value, signed number on 2's complement for comparison with the RSSI. The unit is 1 dB, offset is the same as for <code>RSSI_VAL</code> . The CCA signal goes active when the received signal is below this value. The CCA signal is available on the <code>CCA</code> pin. The reset value is approximately -77 dBm.
7:0	RSSI_VAL[7:0]	-128	R	RSSI estimate on a logarithmic scale, signed number on 2's complement. Unit is 1 dB, offset is described in the RSSI / Energy Detection section on page 48. The <code>RSSI_VAL</code> value is averaged over 8 symbol periods. The <code>RSSI_VALID</code> status bit may be checked to verify that the receiver has been enabled for at least 8 symbol periods. The reset value of -128 also indicates that the <code>RSSI_VAL</code> value is invalid.

SYNCWORD (0x14) - Sync Word

Bit	Field Name	Reset	R/W	Description
15:0	SYNCWORD[15:0]	0xA70F	R/W	<p>Synchronisation word. The SYNCWORD is processed from the least significant nibble (F at reset) to the most significant nibble (A at reset).</p> <p>SYNCWORD is used both during modulation (where 0xF's are replaced with 0x0's) and during demodulation (where 0xF's are not required for frame synchronisation). In reception an implicit zero is required before the first symbol required by SYNCWORD.</p> <p>The reset value is compliant with IEEE 802.15.4.</p>

TXCTRL (0x15) - Transmit Control Register

Bit	Field Name	Reset	R/W	Description
15:14	TXMIXBUF_CUR[1:0]	2	R/W	<p>TX mixer buffer bias current.</p> <p>0: 690uA 1: 980uA 2: 1.16mA (nominal) 3: 1.44mA</p>
13	TX_TURNAROUND	1	R/W	<p>Sets the wait time after STXON before transmission is started.</p> <p>0 : 8 symbol periods (128 us) 1 : 12 symbol periods (192 us)</p>
12:11	TXMIX_CAP_ARRAY[1:0]	0	R/W	Selects varactor array settings in the transmit mixers.
10:9	TXMIX_CURRENT[1:0]	0	R/W	<p>Transmit mixers current:</p> <p>0: 1.72 mA 1: 1.88 mA 2: 2.05 mA 3: 2.21 mA</p>
8:6	PA_CURRENT[2:0]	3	R/W	<p>Current programming of the PA</p> <p>0: -3 current adjustment 1: -2 current adjustment 2: -1 current adjustment 3: Nominal setting 4: +1 current adjustment 5: +2 current adjustment 6: +3 current adjustment 7: +4 current adjustment</p>
5	-	1	W1	Reserved, write as 1.
4:0	PA_LEVEL[4:0]	31	R/W	Output PA level. (-0 dBm)

RXCTRL0 (0x16) – Receive control register 0

Bit	Field Name	Reset	R/W	Description
15:14	–	0	W0	Reserved, write as 0.
13:12	RXMIXBUF_CUR[1:0]	1	R/W	RX mixer buffer bias current. 0: 690uA 1: 980uA (nominal) 2: 1.16mA 3: 1.44mA
11:10	HIGH_LNA_GAIN[1:0]	0	R/W	Controls current in the LNA gain compensation branch in AGC High gain mode. 0: Compensation disabled 1: 100 µA compensation current 2: 300 µA compensation current (Nominal) 3: 1000 µA compensation current
9:8	MED_LNA_GAIN[1:0]	2	R/W	Controls current in the LNA gain compensation branch in AGC Med gain mode.
7:6	LOW_LNA_GAIN[1:0]	3	R/W	Controls current in the LNA gain compensation branch in AGC Low gain mode
5:4	HIGH_LNA_CURRENT[1:0]	2	R/W	Controls main current in the LNA in AGC High gain mode 0: 240 µA LNA current (x2) 1: 480 µA LNA current (x2) 2: 640 µA LNA current (x2) 3: 1280 µA LNA current (x2)
3:2	MED_LNA_CURRENT[1:0]	1	R/W	Controls main current in the LNA in AGC Med gain mode
1:0	LOW_LNA_CURRENT[1:0]	1	R/W	Controls main current in the LNA in AGC Low gain mode

RXCTRL1 (0x17) - Receive control register 1

Bit	Field Name	Reset	R/W	Description
15:14	–	0	W0	Reserved, write as 0.
13	RXBPF_LOCUR	0	R/W	Controls reference bias current to RX bandpass filters: 0: 4 μ A (Reset value) Use 1 instead 1: 3 μ A Note: Recommended setting
12	RXBPF_MIDCUR	0	R/W	Controls reference bias current to RX bandpass filters: 0: 4 μ A (Default) 1: 3.5 μ A
11	LOW_LOWGAIN	1	R/W	LNA low gain mode setting in AGC low gain mode.
10	MED_LOWGAIN	0	R/W	LNA low gain mode setting in AGC medium gain mode.
9	HIGH_HGM	1	R/W	RX Mixers high gain mode setting in AGC high gain mode.
8	MED_HGM	0	R/W	RX Mixers high gain mode setting in AGC medium gain mode.
7:6	LNA_CAP_ARRAY[1:0]	1	R/W	Selects varactor array setting in the LNA 0: OFF 1: 0.1pF (x2) (Nominal) 2: 0.2pF (x2) 3: 0.3pF (x2)
5:4	RXMIX_TAIL[1:0]	1	R/W	Control of the receiver mixers output current. 0: 12 μ A 1: 16 μ A (Nominal) 2: 20 μ A 3: 24 μ A
3:2	RXMIX_VCM[1:0]	1	R/W	Controls VCM level in the mixer feedback loop 0: 8 μ A mixer current 1: 12 μ A mixer current (Nominal) 2: 16 μ A mixer current 3: 20 μ A mixer current
1:0	RXMIX_CURRENT[1:0]	2	R/W	Controls current in the mixer 0: 360 μ A mixer current (x2) 1: 720 μ A mixer current (x2) 2: 900 μ A mixer current (x2) (Nominal) 3: 1260 μ A mixer current (x2)

FSCTRL (0x18) - Frequency Synthesizer Control and Status

Bit	Field Name	Reset	R/W	Description
15:14	LOCK_THR[1:0]	1	R/W	Number of consecutive reference clock periods with successful synchronisation windows required to indicate lock: 0: 64 1: 128 (recommended) 2: 256 3: 512
13	CAL_DONE	0	R	Calibration has been performed since the last time the frequency synthesizer was turned on.
12	CAL_RUNNING	0	R	Calibration status, '1' when calibration in progress and '0' otherwise.
11	LOCK_LENGTH	0	R/W	Synchronisation window pulse width: 0: 2 prescaler clock periods (recommended) 1: 4 prescaler clock periods
10	LOCK_STATUS	0	R	Frequency synthesizer lock status: 0 : Frequency synthesizer is out of lock 1 : Frequency synthesizer is in lock
9:0	FREQ[9:0]	357 (2405 MHz)	R/W	Frequency control word, controlling the RF operating frequency F_c . In transmit mode, the local oscillator (LO) frequency equals F_c . In receive mode, the LO frequency is 2 MHz below F_c . $F_c = 2048 + \text{FREQ}[9:0] \text{ MHz}$ See the Frequency and Channel Programming section on page 50 for further information.

SECCTRL0 (0x19) - Security Control Register

Bit	Field Name	Reset	R/W	Description
15:10	–	0	W0	Reserved, write as 0
9	RXFIFO_PROTECTION	1	R/W	Protection enable of the RXFIFO, see description in the RXFIFO overflow section on page 33. Should be cleared if MAC level security is not used or is implemented outside CC2420.
8	SEC_CBC_HEAD	1	R/W	Defines what to use for the first byte in CBC-MAC (does <i>not</i> apply to CBC-MAC part of CCM): 0 : Use the first data byte as the first byte into CBC-MAC 1 : Use the length of the data to be authenticated (calculated as (the packet length field – SEC_TXL – 2) for TX or using SEC_RXL for RX) as the first byte into CBC-MAC (before the first data byte). This bit should be set high for CBC-MAC 802.15.4 inline security.
7	SEC_SAKKEYSEL	1	R/W	Stand Alone Key select 0 : Key 0 is used 1 : Key 1 is used
6	SEC_TXKEYSEL	1	R/W	TX Key select 0 : Key 0 is used 1 : Key 1 is used
5	SEC_RXKEYSEL	0	R/W	RX Key select 0 : Key 0 is used 1 : Key 1 is used
4:2	SEC_M[2:0]	1	R/W	Number of bytes in authentication field for CBC-MAC, encoded as (M-2)/2 0 : Reserved 1 : 4 2 : 6 3 : 8 4 : 10 5 : 12 6 : 14 7 : 16
1:0	SEC_MODE[1:0]	0	R/W	Security mode 0 : In-line security is disabled 1 : CBC-MAC 2 : CTR 3 : CCM

SECCTRL1 (0x1A) - Security Control Register

Bit	Field Name	Reset	R/W	Description
15	-	0	W0	Reserved, write as 0
14:8	SEC_TXL	0	R/W	Multi-purpose length byte for TX in-line security operations: CTR : Number of cleartext bytes between length byte and the first byte to be encrypted CBC/MAC : Number of cleartext bytes between length byte and the first byte to be authenticated CCM : l(a), defining the number of bytes to be authenticated but not encrypted Stand-alone : SEC_TXL has no effect
7	-	0	W0	Reserved, write as 0
6:0	SEC_RXL	0	R/W	Multi-purpose length byte for RX in-line security operations: CTR : Number of cleartext bytes between length byte and the first byte to be decrypted CBC/MAC : Number of cleartext bytes between length byte and the first byte to be authenticated CCM : l(a), defining the number of bytes to be authenticated but not decrypted Stand-alone : SEC_RXL has no effect

BATTMON (0x1B) – Battery Monitor Control register

Bit	Field Name	Reset	R/W	Description
15:7	-	0	W0	Reserved, write as 0
6	BATTMON_OK	1	R	Battery monitor comparator output, read only. BATT_OK is valid 5 us after BATTMON_EN has been asserted and BATTMON_VOLTAGE has been programmed. 0 : Power supply < Toggle Voltage 1 : Power supply > Toggle Voltage
5	BATTMON_EN	0	R/W	Battery monitor enable 0 : Battery monitor is disabled 1 : Battery monitor is enabled
4:0	BATTMON_VOLTAGE [4:0]	0	R/W	Battery monitor toggle voltage. The toggle voltage is given by: $V_{toggle} = 1.25 V \cdot \frac{72 - BATTMON_VOLTAGE}{27}$

IOCFG0 (0x1C) – I/O Configuration Register 0

Bit	Field Name	Reset	R/W	Description
15:12	–	0	W0	Reserved, write as 0
11	BCN_ACCEPT	0	R/W	Accept all beacon frames when address recognition is enabled. This bit should be set when the PAN identifier programmed into CC2420 RAM is equal to 0xFFFF and cleared otherwise. This bit is don't care when <code>MDMCTRL0.ADR_DECODE = 0</code> . 0 : Only accept beacons with a source PAN identifier which matches the PAN identifier programmed into CC2420 RAM 1 : Accept all beacons regardless of the source PAN identifier
10	FIFO_POLARITY	0	R/W	Polarity of the output signal FIFO. 0 : Polarity is active high 1 : Polarity is active low
9	FIFOP_POLARITY	0	R/W	Polarity of the output signal FIFOP. 0 : Polarity is active high 1 : Polarity is active low
8	SFD_POLARITY	0	R/W	Polarity of the SFD pin. 0 : Polarity is active high 1 : Polarity is active low
7	CCA_POLARITY	0	R/W	Polarity of the CCA pin. 0 : Polarity is active high 1 : Polarity is active low
6:0	FIFOP_THR[6:0]	64	R/W	FIFOP_THR sets the threshold in number of bytes in the RXFIFO for FIFOP to go active.

IOCFG1 (0x1D) – I/O Configuration Register 1

Bit	Field Name	Reset	R/W	Description
15:13	–	0	W0	Reserved, write as 0
12:10	HSSD_SRC [2:0]	0	R/W	<p>The HSSD module is used as follows:</p> <p>0: Off. 1: Output AGC status (gain setting / peak detector status / accumulator value) 2: Output ADC I and Q values. 3: Output I/Q after digital down mix and channel filtering. 4: Reserved 5: Reserved 6: Input ADC I and Q values 7: Input DAC I and Q values.</p> <p>The HSSD module requires that the FS is up and running as it uses CLK_PRE (~150 MHz) to produce its ~37.5 MHz data clock and serialize its output words.</p>
9:5	SFDMUX [4:0]	0	R/W	Multiplexer setting for the SFD pin.
4:0	CCAMUX [4:0]	0	R/W	Multiplexer setting for the CCA pin.

MANFIDL (0x1E) - Manufacturer ID, Lower 16 Bit

Bit	Field Name	Reset	R/W	Description
15:12	PARTNUM [3:0]	2	R	The device part number. CC2420 has part number 0x002.
11:0	MANFID [11:0]	0x33D	R	<p>Gives the JEDEC manufacturer ID. The actual manufacturer ID can be found in MANFID[7:1], the number of continuation bytes in MANFID[11:8] and MANFID[0]=1.</p> <p>Chipcon's JEDEC manufacturer ID is 0x7F 0x7F 0x7F 0x9E (0x1E preceded by three continuation bytes.)</p>

MANFIDH (0x1F) - Manufacturer ID, Upper 16 Bit

Bit	Field Name	Reset	R/W	Description
15:12	VERSION [3:0]	3	R	Version number. Current version is 3. Note that previous CC2420 versions will have lower reset values.
11:0	PARTNUM [15:4]	0	R	The device part number. CC2420 has part number 0x002.

FSMTC (0x20) - Finite state machine time constants

Bit	Field Name	Reset	R/W	Description
15:13	TC_RXCHAIN2RX [2:0]	3	R/W	The time in 5 us steps between the time the RX chain is enabled and the demodulator and AGC is enabled. The RX chain is started when the bandpass filter has been calibrated (after 6.5 symbol periods).
12:10	TC_SWITCH2TX [2:0]	6	R/W	The time in advance the RXTX switch is set high, before enabling TX. In μ s.
9:6	TC_PAON2TX [3:0]	10	R/W	The time in advance the PA is powered up before enabling TX. In μ s.
5:3	TC_TXEND2SWITCH [2:0]	2	R/W	The time after the last chip in the packet is sent, and the TXRX switch is disabled. In μ s.
2:0	TC_TXEND2PAOFF [2:0]	4	R/W	The time after the last chip in the packet is sent, and the PA is set in power-down. Also the time at which the modulator is disabled. In μ s.

MANAND (0x21) - Manual signal AND override register¹

Bit	Field Name	Reset	R/W	Description
15	VGA_RESET_N	1	R/W	The VGA_RESET_N signal is used to reset the peak detectors in the VGA in the RX chain.
14	BIAS_PD	1	R/W	Global bias power down (1)
13	BALUN_CTRL	1	R/W	The BALUN_CTRL signal controls whether the PA should receive its required external biasing (1) or not (0) by controlling the RX/TX output switch.
12	RXTX	1	R/W	RXTX signal: controls whether the LO buffers (0) or PA buffers (1) should be used.
11	PRE_PD	1	R/W	Powerdown of prescaler.
10	PA_N_PD	1	R/W	Powerdown of PA (negative path).
9	PA_P_PD	1	R/W	Powerdown of PA (positive path). When PA_N_PD=1 and PA_P_PD=1 the up-conversion mixers are in powerdown.
8	DAC_LPF_PD	1	R/W	Powerdown of TX DACs.
7	XOSC16M_PD	1	R/W	
6	RXBPF_CAL_PD	1	R/W	Powerdown control of complex bandpass receive filter calibration oscillator.
5	CHP_PD	1	R/W	Powerdown control of charge pump.
4	FS_PD	1	R/W	Powerdown control of VCO, I/Q generator, LO buffers.
3	ADC_PD	1	R/W	Powerdown control of the ADCs.
2	VGA_PD	1	R/W	Powerdown control of the VGA.
1	RXBPF_PD	1	R/W	Powerdown control of complex bandpass receive filter.
0	LNAMIX_PD	1	R/W	Powerdown control of LNA, down-conversion mixers and front-end bias.

¹ For some important signals the value used by analog and digital modules can be overridden manually. This is done as follows for the hypothetical important signal *IS*:

$$IS_USED = (IS * IS_AND_MASK) + IS_OR_MASK,$$

using boolean notation.

The AND-mask and OR-mask for the important signals listed resides in the MANAND and MANOR registers, respectively.

Examples:

- Writing 0xFFFE to MANAND and 0x0000 to MANOR will force LNAMIX_PD=0 whereas all other signals will be unaffected.
- Writing 0xFFFF to MANAND and 0x0001 to MANOR will force LNAMIX_PD=1 whereas all other signals will be unaffected.

MANOR (0x22) - Manual signal OR override register

Bit	Field Name	Reset	R/W	Description
15	VGA_RESET_N	0	R/W	The VGA_RESET_N signal is used to reset the peak detectors in the VGA in the RX chain.
14	BIAS_PD	0	R/W	Global Bias power down (1)
13	BALUN_CTRL	0	R/W	The BALUN_CTRL signal controls whether the PA should receive its required external biasing (1) or not (0) by controlling the RX/TX output switch.
12	RXTX	0	R/W	RXTX signal: controls whether the LO buffers (0) or PA buffers (1) should be used.
11	PRE_PD	0	R/W	Powerdown of prescaler.
10	PA_N_PD	0	R/W	Powerdown of PA (negative path).
9	PA_P_PD	0	R/W	Powerdown of PA (positive path). When PA_N_PD=1 and PA_P_PD=1 the up-conversion mixers are in powerdown.
8	DAC_LPF_PD	0	R/W	Powerdown of TX DACs.
7	XOSC16M_PD	0		
6	RXBPF_CAL_PD	0	R/W	Powerdown control of complex bandpass receive filter calibration oscillator.
5	CHP_PD	0	R/W	Powerdown control of charge pump.
4	FS_PD	0	R/W	Powerdown control of VCO, I/Q generator, LO buffers.
3	ADC_PD	0	R/W	Powerdown control of the ADCs.
2	VGA_PD	0	R/W	Powerdown control of the VGA.
1	RXBPF_PD	0	R/W	Powerdown control of complex bandpass receive filter.
0	LNAMIX_PD	0	R/W	Powerdown control of LNA, down-conversion mixers and front-end bias.

AGCTRL (0x23) - AGC Control

Bit	Field Name	Reset	R/W	Description
15:12	-	0	W0	Reserved, write as 0
11	VGA_GAIN_OE	0	R/W	Use the VGA_GAIN value during RX instead of the AGC value.
10:4	VGA_GAIN [6:0]	0x7F	R/W	When written, VGA manual gain override value; when read, the currently used VGA gain setting.
3:2	LNAMIX_GAINMODE_O [1:0]	0	R/W	LNA / Mixer Gain mode override setting 0 : Gain mode is set by AGC algorithm 1 : Gain mode is always low-gain 2 : Gain mode is always med-gain 3 : Gain mode is always high-gain
1:0	LNAMIX_GAINMODE [1:0]	3	R	Status bit, defining the currently selected gain mode selected by the AGC or overridden by the LNAMIX_GAINMODE_O setting.

AGCTST0 (0x24) - AGC Test Register 0

Bit	Field Name	Reset	R/W	Description
15:12	LNAMIX_HYST[3:0]	3	R/W	Hysteresis on the switching between different RF front-end gain modes, defined in 2 dB steps
11:6	LNAMIX_THR_H[5:0]	25	R/W	Threshold for switching between medium and high RF front-end gain mode, defined in 2 dB steps
5:0	LNAMIX_THR_L[5:0]	9	R/W	Threshold for switching between low and medium RF front-end gain mode, defined in 2 dB steps

AGCTST1 (0x25) - AGC Test Register 1

Bit	Field Name	Reset	R/W	Description
15	–	0	W0	Reserved, write as 0
14	AGC_BLANK_MODE	0	R/W	Set the VGA blanking mode when switching out a gain stage When VGA_GAIN_OE = 0: 0 : Blanking is performed when the AGC algorithm switches out one or more 14dB gain stages. 1 : Blanking is never performed. When VGA_GAIN_OE = 1: Blanking is performed when AGC_BLANK_MODE=1
13	PEAKDET_CUR_BOOST	0	R/W	Doubles the bias current in the peak-detectors in-between the VGA stages when set.
12:11	AGC_SETTLE_WAIT[1:0]	1	R/W	Timing for AGC to wait for analog gain to settle.
10:8	AGC_PEAK_DET_MODE[2:0]	0	R/W	Sets the AGC mode for use of the VGA peak detectors: Bit 2 : Digital ADC peak detector enable / disable Bit 1 : Analog fixed stages peak detector enable / disable Bit 0 : Analog variable gain stage peak detector enable / disable
7:6	AGC_WIN_SIZE[1:0]	1	R/W	Window size for the accumulate and dump function in the AGC. 0 : 8 samples 1 : 16 samples 2 : 32 samples 3 : 64 samples
5:0	AGC_REF[5:0]	20	R/W	Target value for the AGC control loop, given in 2 dB steps. Reset value corresponds to approximately 25% of the ADC dynamic range in reception.

AGCTST2 (0x26) - AGC Test Register 2

Bit	Field Name	Reset	R/W	Description
15:10	–	0	W0	Reserved, write as 0
9:5	MED2HIGHGAIN[4:0]	9	R/W	MED2HIGHGAIN sets the difference in the receiver LNA/MIXER gain from medium gain mode to high gain mode, used by the AGC for setting the correct front-end gain mode.
4:0	LOW2MEDGAIN[4:0]	10	R/W	LOW2MEDGAIN sets the difference in the receiver LNA/MIXER gain from low gain mode to medium gain mode, used by the AGC for setting the correct front-end gain mode.

FSTST0 (0x27) - Frequency Synthesizer Test Register 0

Bit	Field Name	Reset	R/W	Description
15:12	-	0	W0	Reserved, write as 0
11	VCO_ARRAY_SETTLE_LONG	0	R/W	When '1' this control bit doubles the time allowed for VCO settling during VCO calibration.
10	VCO_ARRAY_OE	0	R/W	VCO array manual override enable.
9:5	VCO_ARRAY_O[4:0]	16	R/W	VCO array override value.
4:0	VCO_ARRAY_RES[4:0]	16	R	The VCO array result holds the register content of the most recent calibration.

FSTST1 (0x28) - Frequency Synthesizer Test Register 1

Bit	Field Name	Reset	R/W	Description
15	VCO_TX_NOCAL	0	R/W	0 : VCO calibration is always performed when going to RX or when going to TX. 1 : VCO calibration is only performed when going to RX or when using the STXCAL command strobe
14	VCO_ARRAY_CAL_LONG	1	R/W	When '1' this control bit doubles the time allowed for VCO frequency measurements during VCO calibration. 0 : PLL Calibration time is 37 us 1 : PLL Calibration time is 57 us
13:10	VCO_CURRENT_REF[3:0]	4	R/W	The value of the reference current calibrated against during VCO calibration.
9:4	VCO_CURRENT_K[5:0]	0	R/W	VCO current calibration constant. (Current B override value when FSTST2.VCO_CURRENT_OE=1.)
3	VC_DAC_EN	0	R/W	Controls the source of the VCO VC node in normal operation (TOPTST.VC_IN_TEST_EN=0): 0: Loop filter (closed loop PLL) 1: VC DAC (open loop PLL)
2:0	VC_DAC_VAL[2:0]	2	R/W	VC DAC output value

FSTST2 (0x29) - Frequency Synthesizer Test Register 2

Bit	Field Name	Reset	R/W	Description
15	-	0	W0	Reserved, write as 0.
14:13	VCO_CURCAL_SPEED[1:0]	0	R/W	VCO current calibration speed: 0: Normal 1: Double speed 2: Half speed 3: Undefined.
12	VCO_CURRENT_OE	0	R/W	VCO current manual override enable.
11:6	VCO_CURRENT_O[5:0]	24	R/W	VCO current override value (current A).
5:0	VCO_CURRENT_RES[5:0]	32	R	The VCO current result holds the register content of the most recent calibration.

FSTST3 (0x2A) - Frequency Synthesizer Test Register 3

Bit	Field Name	Reset	R/W	Description
15	CHP_CAL_DISABLE	1	R/W	Disable charge pump during VCO calibration when set.
14	CHP_CURRENT_OE	0	R/W	Charge pump current override enable 0 : Charge pump current set by calibration 1 : Charge pump current set by START_CHP_CURRENT
13	CHP_TEST_UP	0	R/W	Forces the CHP to output "up" current when set
12	CHP_TEST_DN	0	R/W	Forces the CHP to output "down" current when set
11	CHP_DISABLE	0	R/W	Set to manually disable charge pump by masking the up and down pulses from the phase-detector.
10	PD_DELAY	0	R/W	Selects short or long reset delay in phase detector: 0: Short reset delay 1: Long reset delay
9:8	CHP_STEP_PERIOD[1:0]	2	R/W	The charge pump current value step period: 0: 0.25 us 1: 0.5 us 2: 1 us 3: 4 us
7:4	STOP_CHP_CURRENT[3:0]	13	R/W	The charge pump current to stop at after the current is stepped down from START_CHP_CURRENT after VCO calibration is complete. The current is stepped down periodically with intervals as defined in CHP_STEP_PERIOD.
3:0	START_CHP_CURRENT[3:0]	13	R/W	The charge pump current to start with after VCO calibration is complete. The current is then stepped down periodically to the value STOP_CHP_CURRENT with intervals as defined in CHP_STEP_PERIOD. Also used for overriding the charge pump current when CHP_CURRENT_OE='1'

RXBPFST (0x2B) - Receiver Bandpass Filters Test Register

Bit	Field Name	Reset	R/W	Description
15	-	0	W0	Reserved, write as 0.
14	RXBPF_CAP_OE	0	R/W	RX bandpass filter capacitance calibration override enable.
13:7	RXBPF_CAP_O[6:0]	0	R/W	RX bandpass filter capacitance calibration override value.
6:0	RXBPF_CAP_RES[6:0]	0	R	RX bandpass filter capacitance calibration result. 0: Minimum capacitance in the feedback. 1: Second smallest capacitance setting. ... 127: Maximum capacitance in the feedback.

FSMSTATE (0x2C) - Finite state machine information

Bit	Field Name	Reset	R/W	Description
15:6	-	0	W0	Reserved, write as 0.
5:0	FSM_CUR_STATE[5:0]	0	R	Provides the current state of the FIFO and Frame Control (FFCTRL) finite state machine. See the Radio control state machine section on page 43 for details.

ADCTST (0x2D) - ADC Test Register

Bit	Field Name	Reset	R/W	Description
15	ADC_CLOCK_DISABLE	0	R/W	ADC Clock Disable 0 : Clock enabled when ADC enabled 1 : Clock disabled, even if ADC is enabled
14:8	ADC_I[6:0]	0	R	Read the current ADC I-branch value.
7	-	0	W0	Reserved, write as 0.
6:0	ADC_Q[6:0]	0	R	Read the current ADC Q-branch value.

DACTST (0x2E) - DAC Test Register

Bit	Field Name	Reset	R/W	Description
15	-	0	W0	Reserved, write as 0.
14:12	DAC_SRC[2:0]	0	R/W	The TX DACs data source is selected by DAC_SRC according to: 0: Normal operation (from modulator). 1: The DAC_I_O and DAC_Q_O override values below.- 2: From ADC, most significant bits 3: I/Q after digital down mixing and channel filtering. 4: Full-spectrum White Noise (from CRC) 5: From ADC, least significant bits 6: RSSI / Cordic Magnitude Output 7: HSSD module. This feature will often require the DACs to be manually turned on in MANOR and TOPTST.ATESTMOD_MODE=4.
11:6	DAC_I_O[5:0]	0	R/W	I-branch DAC override value.
5:0	DAC_Q_O[5:0]	0	R/W	Q-branch DAC override value.

TOPTST (0x2F) - Top Level Test Register

Bit	Field Name	Reset	R/W	Description
15:8	–	0	W0	Reserved, write as 0.
7	RAM_BIST_RUN	0	R/W	Enable BIST of the RAM 0 : RAM BIST disabled, normal operation 1 : RAM BIST Enabled. Result output to pin, as set in IOCFG1.
6	TEST_BATMON_EN	0	R/W	Enable test output of the battery monitor.
5	VC_IN_TEST_EN	0	R/W	When ATESTMOD_MODE=7 this controls whether the ATEST2 in is used to output the VC node voltage (0) or to control the VC node voltage (1).
4	ATESTMOD_PD	1	R/W	Powerdown of analog test module. 0 : Power up 1 : Power down
3:0	ATESTMOD_MODE[3:0]	0		When ATESTMOD_PD=0, the function of the analog test module is as follows: 0: Outputs “I” (ATEST1) and “Q” (ATEST2) from RxMIX. 1: Inputs “I” (ATEST2) and “Q” (ATEST1) to BPF. 2: Outputs “I” (ATEST1) and “Q” (ATEST2) from VGA. 3: Inputs “I” (ATEST2) and “Q” (ATEST1) to ADC. 4: Outputs “I” (ATEST1) and “Q” (ATEST2) from LPF. 5: Inputs “I” (ATEST2) and “Q” (ATEST1) to TxMIX. 6: Outputs “P” (ATEST1) and “N” (ATEST2) from Prescaler. Must be terminated externally. 7: Connects TX IF to RX IF and simultaneously the ATEST1 pin to the internal VC node (see VC_IN_TEST_EN). 8. Connect ATEST1 (input) to ATEST2 (output) through single2diff and diff2single buffers, used for measurements on the test-interface

RESERVED (0x30) - Reserved register containing spare control and status bits

Bit	Field Name	Reset	R/W	Description
15:0	RES[15:0]	0	R/W	Reserved for future use

TXFIFO (0x3E) – Transmit FIFO Byte register

Bit	Field Name	Reset	R/W	Description
7:0	TXFIFO[7:0]	0	W	Transmit FIFO byte register, write only. Reading the TXFIFO is only possible using RAM read. Note that the crystal oscillator must be running for writing to the TXFIFO.

RXFIFO (0x3F) – Receive FIFO Byte register

Bit	Field Name	Reset	R/W	Description
7:0	RXFIFO[7:0]	0	R/W	Receive FIFO byte register, read / write. Note that the crystal oscillator must be running for accessing the RXFIFO.

38 Test Output Signals

The two digital output pins `CCA` and `SFD`, can be set up to output test signals defined by `IOCFG1.CCAMUX` and

`IOCFG1.SFDMUX`. This is summarized in Table 12 and Table 13 below.

CCAMUX	Signal output on CCA pin	Description
0	CCA	Normal operation
1	ADC_Q[0]	ADC, Q-branch, LSB used for random number generation
2	DEMOD_RESYNC_LATE	High one 16 MHz clock cycle each time the demodulator resynchronises late
3	LOCK_STATUS	Lock status, same as <code>FSCTRL.LOCK_STATUS</code>
4	MOD_CHIPCLK	Chip rate clock signal during transmission
5	MOD_SERIAL_CLK	Bit rate clock signal during transmission
6	FFCTRL_FS_PD	Frequency synthesizer power down, active high
7	FFCTRL_ADC_PD	ADC power down, active high
8	FFCTRL_VGA_PD	VGA power down, active high
9	FFCTRL_RXBPF_PD	Receiver bandpass filter power down, active high
10	FFCTRL_LNAMIX_PD	Receiver LNA / Mixer power down, active high
11	FFCTRL_PA_P_PD	Power amplifier power down, active high
12	AGC_UPDATE	High one 16 MHz clock cycle each time the AGC updates its gain setting
13	VGA_PEAK_DET[1]	VGA Peak detector, gain stage 1
14	VGA_PEAK_DET[3]	VGA Peak detector, gain stage 3
15	AGC_LNAMIX_GAINMODE[1]	RF receiver front-end gain mode, bit 1
16	AGC_VGA_GAIN[1]	VGA gain setting, bit 1
17	VGA_RESET_N	VGA peak-detector reset sign, active low.
18	-	Reserved
19	-	Reserved
20	-	Reserved
21	-	Reserved
22	-	Reserved
23	CLK_8M	8 MHz clock signal output
24	XOSC16M_STABLE	16 MHz crystal oscillator stabilised, same as the status bit in Table 5
25	FSDIG_FREF	Frequency synthesizer, 4 MHz reference signal
26	FSDIG_FPLL	Frequency synthesizer, 4 MHz divided signal
27	FSDIG_LOCK_WINDOW	Frequency synthesizer, lock window
28	WINDOW_SYNC	Frequency synthesizer, synchronized lock window
29	CLK_ADC	ADC clock signal 1
30	ZERO	Low
31	ONE	High

Table 12. CCA test signal select table

SFDMUX	Signal output on SFD pin	Description
0	SFD	Normal operation
1	ADC_I[0]	ADC, I-branch, LSB used for random number generation
2	DEMOD_RESYNCH_EARLY	High one 16 MHz clock cycle each time the demodulator resynchronises early
3	LOCK_STATUS	Lock status, same as FSCTRL.LOCK_STATUS
4	MOD_CHIP	Chip rate data signal during transmission
5	MOD_SERIAL_DATA_OUT	Bit rate data signal during transmission
6	FFCTRL_FS_PD	Frequency synthesizer power down, active high
7	FFCTRL_ADC_PD	ADC power down, active high
8	FFCTRL_VGA_PD	VGA power down, active high
9	FFCTRL_RXBPF_PD	Receiver bandpass filter power down, active high
10	FFCTRL_LNAMIX_PD	Receiver LNA / Mixer power down, active high
11	FFCTRL_PA_P_PD	Power amplifier power down, active high
12	VGA_PEAK_DET[0]	VGA Peak detector, gain stage 0
13	VGA_PEAK_DET[2]	VGA Peak detector, gain stage 2
14	VGA_PEAK_DET[4]	VGA Peak detector, gain stage 4
15	AGC_LNAMIX_GAINMODE[0]	RF receiver front-end gain mode, bit 0
16	AGC_VGA_GAIN[0]	VGA gain setting, bit 0
17	RXBPF_CAL_CLK	Receiver bandpass filter calibration clock
18	-	Reserved
19	-	Reserved
20	-	Reserved
21	-	Reserved
22	-	Reserved
23	-	Reserved
24	PD_F_COMP	Frequency synthesizer frequency comparator value
25	FSDIG_FREF	Frequency synthesizer, 4 MHz reference signal
26	FSDIG_FPLL	Frequency synthesizer, 4 MHz divided signal
27	FSDIG_LOCK_WINDOW	Frequency synthesizer, lock window
28	WINDOW_SYNC	Frequency synthesizer, synchronized lock window
29	CLK_ADC_DIG	ADC clock signal 2
30	ZERO	Low
31	ONE	High

Table 13. SFD test signal select table

39 Soldering information

Recommended soldering profile is according to IPC/JEDEC J-STD-020C. Please see the CC2420EM reference design for details on layout.

40 General Information

40.1 Document History

Revision	Date	Description/Changes
SWRS041c	2013-02-20	Changed packaging and orderable information to reflect change to RGZ package.
SWRS041b	2007-03-19	Slightly changed optimum load impedance on Page 9 and 19 to better describe the Application circuit.
SWRS041a	2006-12-18	Updated ordering information. Updated address information. Typical data latency changed from 2 to 3 us. Updates reflecting the programmable polarity of FIFO, FIFOP, SFD and CCA pins. Clarification relating to VREG_EN as digital input. BATT_OK changed to BATTMON_OK for consistency. MANFIDH.VERSION register, reset value changed to "current version is 3". Added reset values for several registers. Some typographical changes. Removed Chipcon specific Disclaimer, Trademarks and Life Support Policy sections.
SWRS041 (1.4)	2006-04-06	Ordering part number changed from CC2420-RTB2 and CC2420-RTR2 to CC2420Z-RTB1 and CC2420Z-RTR1 respectively.
1.3	2005-10-03	Important: New recommended setting for RXBPF_LOCUR in RXCTRL1 (0x17) use 1 instead of reset value 0. Updated address information. Added new balun circuit with transmission lines in section Application Circuit. Updated electrical specifications with measured data on CC2420 EM with new balun. Updated values and figure for suggested application circuit with folded dipole antenna. Corrected values for capacitors in Table 2, discrete balun. Added data latency figure in receiver specification. Updated crystal oscillator start up time. Updated PLL loop filter bandwidth. Updated adjacent channel rejection figures. Updated current consumption for RX mode. Typographical errors corrected in text and figures. Removed comment about tuning capacitor for crystal oscillator. Added statement that RAM access shall not be used for FIFO access. Added more details about RSSI. Clarified the interpretation of a programmed synchronisation word. Updated purchasing information. Updated soldering standard. Added chapter numbering and split table for electrical specifications for readability. Gathered and added information related to pin configurations in section 13. Included TX_UNDERFLOW and RX_UNDERFLOW in state diagram. Disclaimer updated to include Z-stack™ information. Product status changed to "Full Production".

Revision	Date	Description/Changes
1.2	2004-06-09	<p>Output power range: 24 dB (was 40 dB). Deleted option for single ended external PA. Adjacent channel rejection corrected to 46 dB for + 5MHz (was 39 dB), 39 dB for -5 MHz (was 46 dB) 58 dB for +10 MHz (was 53 dB) and 55 dB for -10 MHz (was 57 dB). "image channel" deleted in text for In band spurious reception. Revision for reference [1] updated. CSMA-CA added to abbreviations. Schematic view of the IEEE 802.15.4 Frame Format corrected, address field 0 to 20 bits. Changed blocking specifications to relate to EN 300 440 class 2. Updated addresses for Chipcon offices. Added section Operating Conditions. Section RAM access: A6:0 (LSB). IOCFG0.BCN_ACCEPT bit added and described in section Address recognition and the IOCFG0 register. The previous IDLE mode has been renamed to power down to be consistent with other Chipcon data sheets. Three power modes defined: Voltage regulator off (OFF), Power down (PD) (Voltage regulator enabled), IDLE (XOSC running) and used throughout the document. Default TXMIXBUF_CUR[1:0] in table for TXCTRL set to 2. Added information: compliance with EN 300 328 og EN 300 440 (Class 2). Added more information about FIFO in section Receive mode. Removed text about SO programmable pull up from entire document. In Voltage regulator section of Electrical Specifications: voltage regulator may only supply CC2420. MANFIDH.VERSION register, changed to "current version is 2". Included package height in package drawing. Included layout drawing for package. Power supply pins defined clearer in Absolute maximum ratings. Third harmonic level corrected to -51dBm in Electrical specifications, second harmonic to -37dBm. Table with Crystal oscillator component values corrected. Link to reference [3] corrected. Corrected spelling grammar and references to tables and figures. Figure showing SmartRF Studio user interface included. Added figure to describe pin activity during RXFIFO read out. Added description on how to connect pins when not using internal regulator.</p>
1.1	2004-03-22	<p>Application circuits: Pin 20 and pin 37 connected to 1.8 V from VREG_OUT. IOCFG0.SO_PULLUP deleted. Added document history table.</p>
1.0	2003-11-17	Initial release.

PACKAGING INFORMATION

Orderable part number	Status (1)	Material type (2)	Package Pins	Package qty Carrier	RoHS (3)	Lead finish/ Ball material (4)	MSL rating/ Peak reflow (5)	Op temp (°C)	Part marking (6)
CC2420RGZR	Active	Production	VQFN (RGZ) 48	2500 LARGE T&R	Yes	NIPDAU	Level-3-260C-168 HR	-40 to 85	CC2420
CC2420RGZR.A	Active	Production	VQFN (RGZ) 48	2500 LARGE T&R	Yes	NIPDAU	Level-3-260C-168 HR	-40 to 85	CC2420
CC2420RGZT	Active	Production	VQFN (RGZ) 48	250 SMALL T&R	Yes	NIPDAU	Level-3-260C-168 HR	-40 to 85	CC2420
CC2420RGZT.A	Active	Production	VQFN (RGZ) 48	250 SMALL T&R	Yes	NIPDAU	Level-3-260C-168 HR	-40 to 85	CC2420

(1) **Status:** For more details on status, see our [product life cycle](#).

(2) **Material type:** When designated, preproduction parts are prototypes/experimental devices, and are not yet approved or released for full production. Testing and final process, including without limitation quality assurance, reliability performance testing, and/or process qualification, may not yet be complete, and this item is subject to further changes or possible discontinuation. If available for ordering, purchases will be subject to an additional waiver at checkout, and are intended for early internal evaluation purposes only. These items are sold without warranties of any kind.

(3) **RoHS values:** Yes, No, RoHS Exempt. See the [TI RoHS Statement](#) for additional information and value definition.

(4) **Lead finish/Ball material:** Parts may have multiple material finish options. Finish options are separated by a vertical ruled line. Lead finish/Ball material values may wrap to two lines if the finish value exceeds the maximum column width.

(5) **MSL rating/Peak reflow:** The moisture sensitivity level ratings and peak solder (reflow) temperatures. In the event that a part has multiple moisture sensitivity ratings, only the lowest level per JEDEC standards is shown. Refer to the shipping label for the actual reflow temperature that will be used to mount the part to the printed circuit board.

(6) **Part marking:** There may be an additional marking, which relates to the logo, the lot trace code information, or the environmental category of the part.

Multiple part markings will be inside parentheses. Only one part marking contained in parentheses and separated by a "~" will appear on a part. If a line is indented then it is a continuation of the previous line and the two combined represent the entire part marking for that device.

Important Information and Disclaimer: The information provided on this page represents TI's knowledge and belief as of the date that it is provided. TI bases its knowledge and belief on information provided by third parties, and makes no representation or warranty as to the accuracy of such information. Efforts are underway to better integrate information from third parties. TI has taken and continues to take reasonable steps to provide representative and accurate information but may not have conducted destructive testing or chemical analysis on incoming materials and chemicals. TI and TI suppliers consider certain information to be proprietary, and thus CAS numbers and other limited information may not be available for release.

In no event shall TI's liability arising out of such information exceed the total purchase price of the TI part(s) at issue in this document sold by TI to Customer on an annual basis.

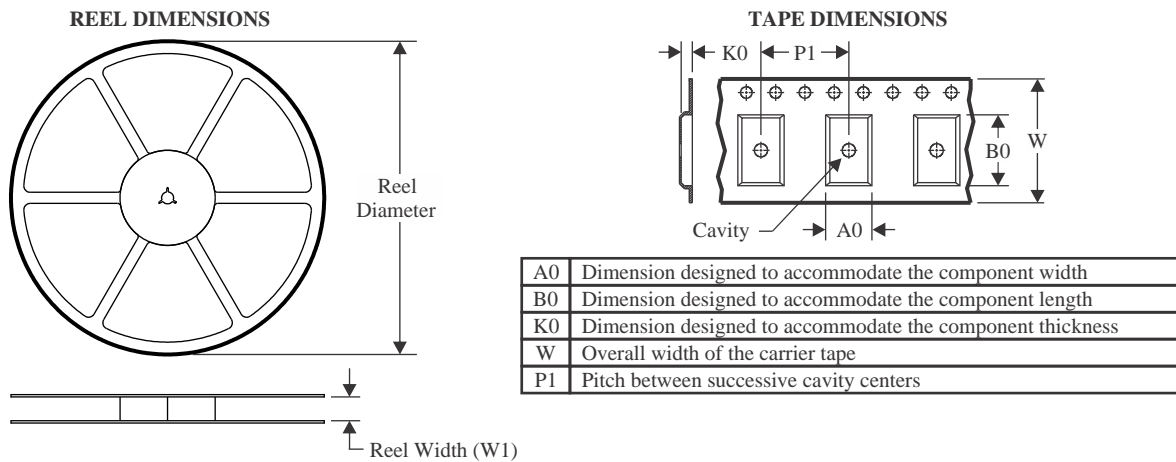
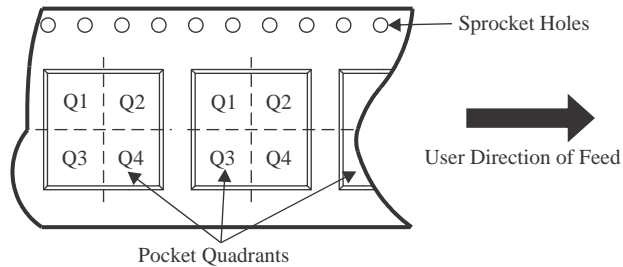
TAPE AND REEL INFORMATION

QUADRANT ASSIGNMENTS FOR PIN 1 ORIENTATION IN TAPE

*All dimensions are nominal

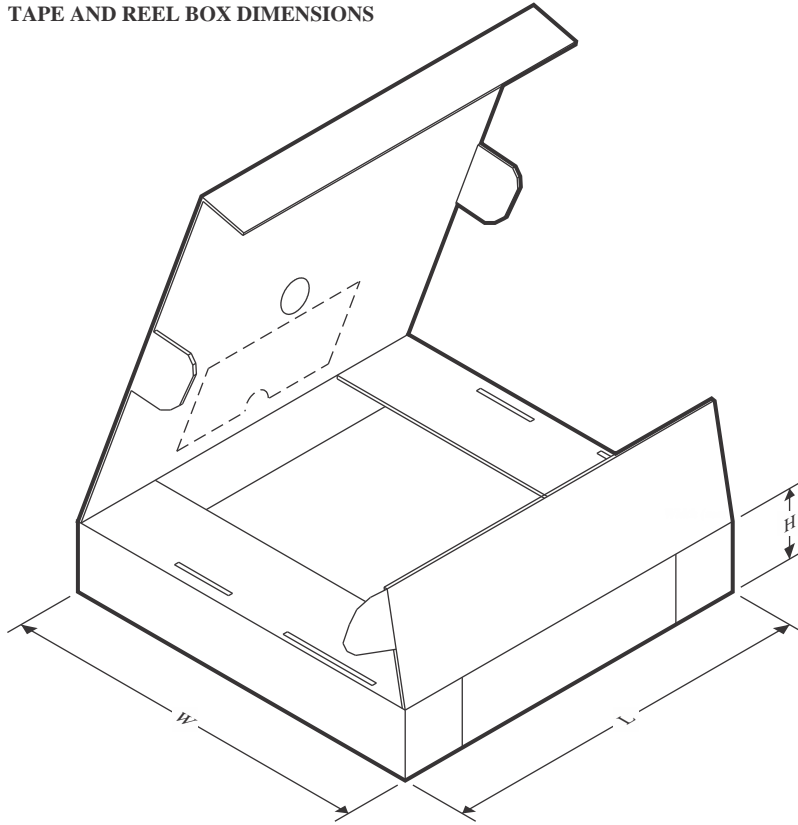
Device	Package Type	Package Drawing	Pins	SPQ	Reel Diameter (mm)	Reel Width W1 (mm)	A0 (mm)	B0 (mm)	K0 (mm)	P1 (mm)	W (mm)	Pin1 Quadrant
CC2420RGZR	VQFN	RGZ	48	2500	330.0	16.4	7.3	7.3	1.5	12.0	16.0	Q2

TAPE AND REEL BOX DIMENSIONS

*All dimensions are nominal

Device	Package Type	Package Drawing	Pins	SPQ	Length (mm)	Width (mm)	Height (mm)
CC2420RGZR	VQFN	RGZ	48	2500	350.0	350.0	43.0

GENERIC PACKAGE VIEW

RGZ 48

VQFN - 1 mm max height

7 x 7, 0.5 mm pitch

PLASTIC QUADFLAT PACK- NO LEAD

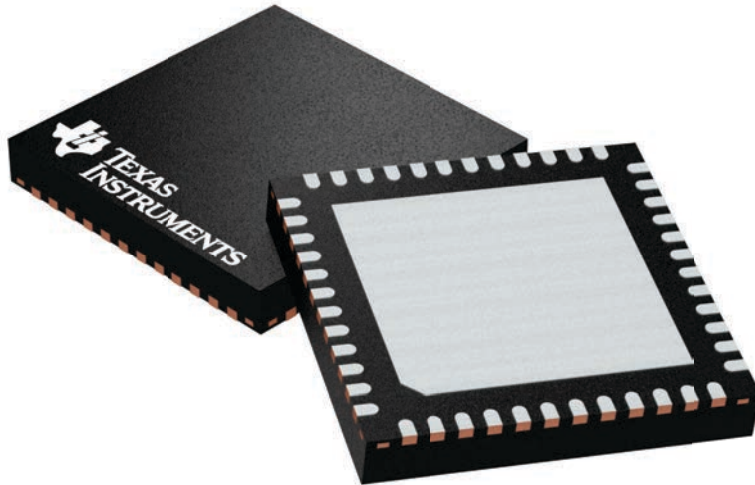

Images above are just a representation of the package family, actual package may vary.
Refer to the product data sheet for package details.

4224671/A

IMPORTANT NOTICE AND DISCLAIMER

TI PROVIDES TECHNICAL AND RELIABILITY DATA (INCLUDING DATASHEETS), DESIGN RESOURCES (INCLUDING REFERENCE DESIGNS), APPLICATION OR OTHER DESIGN ADVICE, WEB TOOLS, SAFETY INFORMATION, AND OTHER RESOURCES "AS IS" AND WITH ALL FAULTS, AND DISCLAIMS ALL WARRANTIES, EXPRESS AND IMPLIED, INCLUDING WITHOUT LIMITATION ANY IMPLIED WARRANTIES OF MERCHANTABILITY, FITNESS FOR A PARTICULAR PURPOSE OR NON-INFRINGEMENT OF THIRD PARTY INTELLECTUAL PROPERTY RIGHTS.

These resources are intended for skilled developers designing with TI products. You are solely responsible for (1) selecting the appropriate TI products for your application, (2) designing, validating and testing your application, and (3) ensuring your application meets applicable standards, and any other safety, security, regulatory or other requirements.

These resources are subject to change without notice. TI grants you permission to use these resources only for development of an application that uses the TI products described in the resource. Other reproduction and display of these resources is prohibited. No license is granted to any other TI intellectual property right or to any third party intellectual property right. TI disclaims responsibility for, and you fully indemnify TI and its representatives against any claims, damages, costs, losses, and liabilities arising out of your use of these resources.

TI's products are provided subject to [TI's Terms of Sale](#), [TI's General Quality Guidelines](#), or other applicable terms available either on ti.com or provided in conjunction with such TI products. TI's provision of these resources does not expand or otherwise alter TI's applicable warranties or warranty disclaimers for TI products. Unless TI explicitly designates a product as custom or customer-specified, TI products are standard, catalog, general purpose devices.

TI objects to and rejects any additional or different terms you may propose.

Copyright © 2026, Texas Instruments Incorporated

Last updated 10/2025