

AMC0381R Precision, High-Voltage DC Input, Reinforced Isolated Amplifier With Single-Ended Ratiometric Output

1 Features

- Integrated, high-voltage resistive divider for direct DC voltage sensing without external resistors
- Single-ended output, ratiometric to V_{REFIN}
 - Reference input: 2.7V to 5.5V
- Supply voltage range:
 - High-side (VDD1): 3.0V to 5.5V
 - Low-side (VDD2): 3.0V to 5.5V
- Low DC errors:
 - Offset error: $\pm 1.5\text{mV}$ (maximum)
 - Offset drift: $\pm 20\mu\text{V}/^\circ\text{C}$ (maximum)
 - Attenuation error: $\pm 0.25\%$ (maximum)
 - Attenuation drift: $\pm 40\text{ppm}/^\circ\text{C}$ (maximum)
 - Nonlinearity: 0.025% (maximum)
- High CMTI: 150V/ns (minimum)
- Low EMI: Meets CISPR-11 and CISPR-25 limits
- Available input options:
 - AMC0381R06: 600V, 10M Ω
 - AMC0381R10: 1000V, 12.5M Ω
 - AMC0381R16: 1600V, 33.5M Ω
- Safety-related certifications:
 - 7000V_{PK} reinforced isolation per DIN EN IEC 60747-17 (VDE 0884-17)
 - 5000V_{RMS} isolation for 1 minute per UL 1577
- Fully specified over the extended industrial temperature range: -40°C to $+125^\circ\text{C}$

2 Applications

- [Server power-supply units \(PSU\)](#)
- [Energy storage systems \(ESS\)](#)
- [Solar inverters](#)
- [EV charging stations](#)

3 Description

The AMC0381R is a precision, galvanically isolated amplifier with a high-voltage DC, high impedance input, and single-ended ratiometric output. The input is designed to connect directly to a high-voltage signal source.

The isolation barrier separates parts of the system that operate on different common-mode voltage levels. The isolation barrier is highly resistant to magnetic interference and is certified to provide reinforced isolation up to 5kV_{RMS} (60s).

The AMC0381R outputs a single-ended signal proportional to the input voltage. The full-scale output is set by the voltage applied to the REFIN pin. The output of the AMC0381R is designed to connect directly to the input of an ADC. Connect REFIN to the same reference voltage as the ADC to match the dynamic input voltage range of the ADC.

The AMC0381R is available in three linear input voltage ranges: 600V, 1000V, and 1600V. With an integrated precision resistive divider, the AMC0381R achieves better than 1% accuracy over the full temperature range, including lifetime drift.

The AMC0381R is available in a 15-pin, 0.65mm pitch SSOP package. The device is fully specified over the temperature range from -40°C to $+125^\circ\text{C}$.

Package Information

PART NUMBER	PACKAGE ⁽¹⁾	PACKAGE SIZE ⁽²⁾
AMC0381R	DFX (SSOP, 15)	12.8mm × 10.3mm

(1) For more information, see the [Mechanical, Packaging, and Orderable Information](#).

(2) The package size (length × width) is a nominal value and includes pins, where applicable.

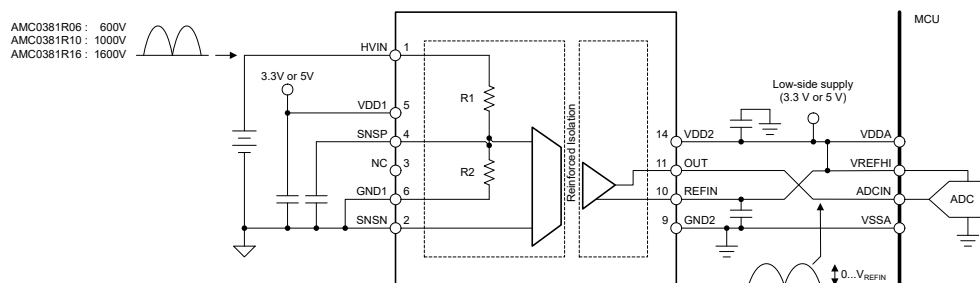

Typical Application



Table of Contents

1 Features	1	7.1 Overview.....	17
2 Applications	1	7.2 Functional Block Diagram.....	17
3 Description	1	7.3 Feature Description.....	17
4 Device Comparison Table	3	7.4 Device Functional Modes.....	20
5 Pin Configuration and Functions	4	8 Application and Implementation	21
6 Specifications	5	8.1 Application Information.....	21
6.1 Absolute Maximum Ratings.....	5	8.2 Typical Application.....	21
6.2 ESD Ratings.....	5	8.3 Best Design Practices.....	23
6.3 Recommended Operating Conditions.....	5	8.4 Power Supply Recommendations.....	24
6.4 Thermal Information.....	7	8.5 Layout.....	25
6.5 Power Ratings.....	7	9 Device and Documentation Support	26
6.6 Insulation Specifications.....	8	9.1 Documentation Support.....	26
6.7 Safety-Related Certifications.....	9	9.2 Receiving Notification of Documentation Updates.....	26
6.8 Safety Limiting Values.....	9	9.3 Support Resources.....	26
6.9 Electrical Characteristics.....	10	9.4 Trademarks.....	26
6.10 Switching Characteristics.....	11	9.5 Electrostatic Discharge Caution.....	26
6.11 Timing Diagram.....	11	9.6 Glossary.....	26
6.12 Insulation Characteristics Curves.....	12	10 Revision History	26
6.13 Typical Characteristics.....	13	11 Mechanical, Packaging, and Orderable Information	26
7 Detailed Description	17		

4 Device Comparison Table

Table 4-1. Device Comparison

DEVICE	R1 ⁽¹⁾	R2 ⁽¹⁾	DIVIDER RATIO	LINEAR INPUT RANGE	CLIPPING VOLTAGE	ABS MAX INPUT VOLTAGE
AMC0381R06	10MΩ	16.7kΩ	601:1	600V	769V	900V
AMC0381R10	12.5MΩ	12.5kΩ	1001:1	1000V	1281V	1500V
AMC0381R16	33.5MΩ	21kΩ	1601:1	1600V	2049V	2000V

(1) R1 and R2 are approximated resistor values and do not accurately reflect the divider ratio.

5 Pin Configuration and Functions

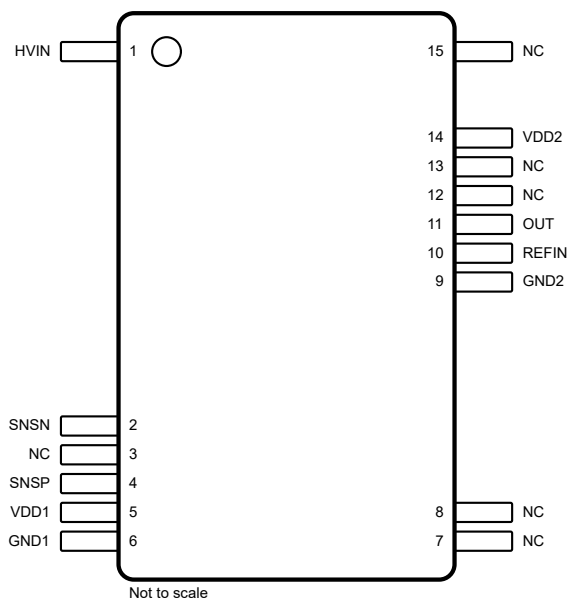

Figure 5-1. DFX Package, 15-Pin SOIC (Top View)

Table 5-1. Pin Functions

PIN		TYPE	DESCRIPTION
NO.	NAME		
1	HVIN	Analog input	High-voltage input
2	SNSN	Analog input	GND1 sense pin and inverting analog input to the amplifier. Connect to GND1.
3, 7, 8, 12, 13, 15	NC	N/A	No internal connection. The pin can be connected to any potential or left floating
4	SNSP	Analog input	Sense voltage pin and noninverting analog input to the amplifier. Connect to an external filter capacitor or leave floating.
5	VDD1	High-side power	Analog (high-side) power supply ⁽¹⁾
6	GND1	High-side ground	High-side ground
9	GND2	Low-side ground	Low-side ground
10	REFIN	Analog input	The voltage applied to this pin sets the full-scale output of the device. Internally, a 96kΩ resistor is connected from REFIN to GND2. For best accuracy, connect REFIN to a low-impedance source as described in the Connecting the REFIN Pin section.
11	OUT	Analog output	Analog output
14	VDD2	Low-side power	Low-side power supply ⁽¹⁾

(1) See the [Power Supply Recommendations](#) section for power-supply decoupling recommendations.

6 Specifications

6.1 Absolute Maximum Ratings

see⁽¹⁾

		MIN	MAX	UNIT
Power-supply voltage	High-side, VDD1 to GND1	-0.3	6.5	V
	Low-side, VDD2 to GND2	-0.3	6.5	
Analog input voltage	HVIN to GND1, AMC0381R06	-150	900	V
	HVIN to GND1, AMC0381R10	-150	1500	
	HVIN to GND1, AMC0381R16	-150	2000	
	SNSP, SNSN	GND1 - 0.5	VDD1 + 0.5	
Reference input voltage	REFIN to GND2	GND2 - 0.5	VDD2 + 0.5	V
Analog output voltage	OUT	GND2 - 0.5	VDD2 + 0.5	V
Input current	Continuous, any pin except power-supply and HVIN pins	-10	10	mA
Temperature	Junction, T _J		150	°C
	Storage, T _{stg}	-65	150	

- (1) Operation outside the *Absolute Maximum Ratings* may cause permanent device damage. *Absolute Maximum Ratings* do not imply functional operation of the device at these or any other conditions beyond those listed under *Recommended Operating Conditions*. If used outside the Recommended Operating Conditions but within the Absolute Maximum Ratings, the device may not be fully functional, and this may affect device reliability, functionality, performance, and shorten the device lifetime

6.2 ESD Ratings

			VALUE	UNIT
V _(ESD)	Electrostatic discharge	Human-body model (HBM), per ANSI/ESDA/JEDEC JS-001 ⁽¹⁾	±2000	V
		Charged-device model (CDM), per ANSI/ESDA/JEDEC JS-002 ⁽²⁾	±1000	

- (1) JEDEC document JEP155 states that 500-V HBM allows safe manufacturing with a standard ESD control process.
(2) JEDEC document JEP157 states that 250-V CDM allows safe manufacturing with a standard ESD control process.

6.3 Recommended Operating Conditions

over operating ambient temperature range (unless otherwise noted)

			MIN	NOM	MAX	UNIT
POWER SUPPLY						
VDD1	High-side power supply	VDD1 to GND1	3	5.0	5.5	V
VDD2	Low-side power supply	VDD2 to GND2	3	3.3	5.5	V
ANALOG INPUT						
V _{Clipping}	Nominal input voltage before clipping output	Referred to SNSP	0		1.28	V
		Referred to HVIN, AMC0381R06	0		769	
		Referred to HVIN, AMC0381R10	0		1281	
		Referred to HVIN, AMC0381R16	0		2049	
V _{FSR}	Specified linear input voltage ⁽¹⁾	Referred to SNSP	0.038		1	V
		Referred to HVIN, AMC0381R06	23		600	
		Referred to HVIN, AMC0381R10	38		1000	
		Referred to HVIN, AMC0381R16	60		1600	
REFERENCE INPUT						
V _{REFIN}	Reference input voltage	REFIN to GND2	2.7		VDD2	V
ANALOG OUTPUT						
C _{LOAD}	Capacitive load	OUT to GND2			500	pF

over operating ambient temperature range (unless otherwise noted)

			MIN	NOM	MAX	UNIT
R _{LOAD}	Resistive load	OUT to GND2		10	1	kΩ
TEMPERATURE RANGE						
T _A	Specified ambient temperature		-40		125	°C

(1) At V_{REFIN} = 5V. See the *Analog Output* section for details.

6.4 Thermal Information

THERMAL METRIC ⁽¹⁾		DFX (SSOP)	UNIT
		15 PINS	
$R_{\theta JA}$	Junction-to-ambient thermal resistance	86.9	°C/W
$R_{\theta JC(top)}$	Junction-to-case (top) thermal resistance	36.7	°C/W
$R_{\theta JB}$	Junction-to-board thermal resistance	43.5	°C/W
Ψ_{JT}	Junction-to-top characterization parameter	17	°C/W
Ψ_{JB}	Junction-to-board characterization parameter	41.8	°C/W
$R_{\theta JC(bot)}$	Junction-to-case (bottom) thermal resistance	N/A	°C/W

(1) For more information about traditional and new thermal metrics, see the [Semiconductor and IC Package Thermal Metrics](#) application note.

6.5 Power Ratings

PARAMETER	TEST CONDITIONS	VALUE	UNIT
P_D	Maximum power dissipation (both sides) AVDD = DVDD = 5.5V, $V_{HVIN} = V_{Clipping}$ AMC0381R06	130	mW
	AVDD = DVDD = 5.5V, $V_{HVIN} = V_{Clipping}$ AMC0381R10	200	
	AVDD = DVDD = 5.5V, $V_{HVIN} = V_{Clipping}$ AMC0381R16	190	
P_{D1}	Maximum power dissipation (high-side) AVDD = 5.5V, $V_{HVIN} = V_{Clipping}$ AMC0381R06	90	mW
	AVDD = 5.5V, $V_{HVIN} = V_{Clipping}$ AMC0381R10	160	
	AVDD = 5.5V, $V_{HVIN} = V_{Clipping}$ AMC0381R16	150	
P_{D2}	Maximum power dissipation (low-side) DVDD = 5.5V	40	mW

6.6 Insulation Specifications

over operating ambient temperature range (unless otherwise noted)

PARAMETER		TEST CONDITIONS	VALUE	UNIT
GENERAL				
CLR	External clearance ⁽¹⁾	Shortest pin-to-pin distance through air	≥ 8	mm
CPG	External creepage ⁽¹⁾	Shortest pin-to-pin distance across the package surface	≥ 9.7	mm
DTI	Distance through insulation	Minimum internal gap (internal clearance) of the double insulation	≥ 15.4	μm
CTI	Comparative tracking index	DIN EN 60112 (VDE 0303-11); IEC 60112	≥ 600	V
	Material group	According to IEC 60664-1	I	
	Overvoltage category per IEC 60664-1	Rated mains voltage ≤ 600V _{RMS}	I-III	
		Rated mains voltage ≤ 1000V _{RMS}	I-II	
DIN EN IEC 60747-17 (VDE 0884-17)⁽²⁾				
V _{IORM}	Maximum repetitive peak isolation voltage	At AC voltage	2120	V _{PK}
V _{IOWM}	Maximum-rated isolation working voltage	At AC voltage (sine wave)	1500	V _{RMS}
		At DC voltage	2120	V _{DC}
V _{IOTM}	Maximum transient isolation voltage	V _{TEST} = V _{IOTM} , t = 60s (qualification test), V _{TEST} = 1.2 × V _{IOTM} , t = 1s (100% production test)	7000	V _{PK}
V _{IMP}	Maximum impulse voltage ⁽³⁾	Tested in air, 1.2/50μs waveform per IEC 62368-1	7700	V _{PK}
V _{IOSM}	Maximum surge isolation voltage ⁽⁴⁾	Tested in oil (qualification test), 1.2/50μs waveform per IEC 62368-1	10000	V _{PK}
q _{pd}	Apparent charge ⁽⁵⁾	Method a, after input/output safety test subgroups 2 and 3, V _{pd(ini)} = V _{IOTM} , t _{ini} = 60s, V _{pd(m)} = 1.2 × V _{IORM} , t _m = 10s	≤ 5	pC
		Method a, after environmental tests subgroup 1, V _{pd(ini)} = V _{IOTM} , t _{ini} = 60s, V _{pd(m)} = 1.6 × V _{IORM} , t _m = 10s	≤ 5	
		Method b1, at preconditioning (type test) and routine test, V _{pd(ini)} = 1.2 × V _{IOTM} , t _{ini} = 1s, V _{pd(m)} = 1.875 × V _{IORM} , t _m = 1s	≤ 5	
		Method b2, at routine test (100% production) ⁽⁷⁾ V _{pd(ini)} = V _{pd(m)} = 1.2 × V _{IOTM} , t _{ini} = t _m = 1s	≤ 5	
C _{IO}	Barrier capacitance, input to output ⁽⁶⁾	V _{IO} = 0.5V _{PP} at 1MHz	≈ 1.5	pF
R _{IO}	Insulation resistance, input to output ⁽⁶⁾	V _{IO} = 500V at T _A = 25°C	> 10 ¹²	Ω
		V _{IO} = 500V at 100°C ≤ T _A ≤ 125°C	> 10 ¹¹	
		V _{IO} = 500V at T _S = 150°C	> 10 ⁹	
	Pollution degree		2	
	Climatic category		55/125/21	
UL1577				
V _{ISO}	Withstand isolation voltage	V _{TEST} = V _{ISO} , t = 60s (qualification test), V _{TEST} = 1.2 × V _{ISO} , t = 1s (100% production test)	5000	V _{RMS}

- (1) Apply creepage and clearance requirements according to the specific equipment isolation standards of an application. Care must be taken to maintain the creepage and clearance distance of a board design to ensure that the mounting pads of the isolator on the printed circuit board (PCB) do not reduce this distance. Creepage and clearance on a PCB become equal in certain cases. Techniques such as inserting grooves, ribs, or both on a PCB are used to help increase these specifications.
- (2) This coupler is suitable for *safe electrical insulation* only within the safety ratings. Compliance with the safety ratings shall be ensured by means of suitable protective circuits.
- (3) Testing is carried out in air to determine the surge immunity of the package.
- (4) Testing is carried in oil to determine the intrinsic surge immunity of the isolation barrier.
- (5) Apparent charge is electrical discharge caused by a partial discharge (pd).
- (6) All pins on each side of the barrier are tied together, creating a two-pin device.
- (7) Either method b1 or b2 is used in production.

6.7 Safety-Related Certifications

VDE	UL
DIN EN IEC 60747-17 (VDE 0884-17), EN IEC 60747-17, DIN EN IEC 62368-1 (VDE 0868-1), EN IEC 62368-1, IEC 62368-1 Clause : 5.4.3 ; 5.4.4.4 ; 5.4.9	Recognized under 1577 component recognition and CSA component acceptance NO 5 programs
Reinforced insulation	Single protection
Certificate number: Pending	File number: Pending

6.8 Safety Limiting Values

Safety limiting⁽¹⁾ intends to minimize potential damage to the isolation barrier upon failure of input or output circuitry. A failure of the I/O can allow low resistance to ground or the supply and, without current limiting, dissipate sufficient power to over-heat the die and damage the isolation barrier potentially leading to secondary system failures.

PARAMETER		TEST CONDITIONS	MIN	TYP	MAX	UNIT
I _{SI}	Safety input current	R _{θJA} = 86.9°C/W, VDDx = 5.5V, T _J = 150°C, T _A = 25°C, AMC0381R06			250	mA
		R _{θJA} = 86.9°C/W, VDDx = 5.5V, T _J = 150°C, T _A = 25°C, AMC0381R10			240	
		R _{θJA} = 86.9°C/W, VDDx = 5.5V, T _J = 150°C, T _A = 25°C, AMC0381R16			240	
I _{SO}	Safety output current	R _{θJA} = 86.9°C/W, VDDx = 5.5V, T _J = 150°C, T _A = 25°C			260	mA
P _S	Safety input, output, or total power	R _{θJA} = 86.9°C/W, T _J = 150°C, T _A = 25°C			1440	mW
T _S	Maximum safety temperature				150	°C

- (1) The maximum safety temperature, T_S, has the same value as the maximum junction temperature, T_J, specified for the device. The I_S and P_S parameters represent the safety current and safety power, respectively. Do not exceed the maximum limits of I_S and P_S. These limits vary with the ambient temperature, T_A.

The junction-to-air thermal resistance, R_{θJA}, in the Thermal Information table is that of a device installed on a high-K test board for leaded surface-mount packages. Use these equations to calculate the value for each parameter:

$T_J = T_A + R_{\theta JA} \times P$, where P is the power dissipated in the device.

$T_{J(max)} = T_S = T_A + R_{\theta JA} \times P_S$, where T_{J(max)} is the maximum junction temperature.

$P_S = I_S \times VDD_{max}$, where VDD_{max} is the maximum supply voltage for high-side and low-side.

6.9 Electrical Characteristics

minimum and maximum specifications apply from $T_A = -40^\circ\text{C}$ to $+125^\circ\text{C}$, $V_{DD1} = 3.0\text{V}$ to 5.5V , $V_{DD2} = 3.0\text{V}$ to 5.5V , $V_{REFIN} = 3.3\text{V}$, $V_{SNSP} = 0\text{V}$ to $+1\text{V}$, and $V_{SNSN} = 0\text{V}$; typical specifications are at $T_A = 25^\circ\text{C}$, $V_{DD1} = 5\text{V}$, $V_{DD2} = 3.3\text{V}$ (unless otherwise noted)

PARAMETER		TEST CONDITIONS	MIN	TYP	MAX	UNIT
ANALOG INPUT						
R_{IN}	Input resistance	AMC0381R06	8.5	10	11.5	M Ω
		AMC0381R10	10.6	12.5	14.4	
		AMC0381R16	28	33.5	39	
	Resistive divider ratio	V_{HVIN} / V_{SNSP} , AMC0381R06	598	601	604	V/V
		V_{HVIN} / V_{SNSP} , AMC0381R10	996	1001	1006	
		V_{HVIN} / V_{SNSP} , AMC0381R16	1596	1601	1606	
CMTI	Common-mode transient immunity	SNSP = GND1	150			V/ns
REFERENCE INPUT						
R_{REFIN}	DC input impedance	REFIN to GND2, $T_A = 25^\circ\text{C}$	81	96	111	k Ω
TCR_{REFIN}	Input impedance thermal drift			-235		ppm/ $^\circ\text{C}$
ANALOG OUTPUT						
	Nominal attenuation	V_{HVIN} / V_{OUT}		$\frac{V_{REFIN}}{ V_{Clipping} }$		V/V
$V_{OUT, SAT}$	Output saturation voltage	HVIN = GND1, $V_{REFIN} = 3.3\text{V}$, $I_{OUT} = -1\text{mA}$ (sinking)			150	mV
R_{OUT}	Output resistance			<0.2		Ω
	Output short-circuit current	sourcing or sinking, HVIN = GND1, output shorted to either GND or VDD2		11		mA
DC ACCURACY						
V_{OS}	Input offset voltage	Referred to SNSP, $T_A = 25^\circ\text{C}$, $V_{SNSP} = 0.25\text{V}$	-1.5	± 0.4	1.5	mV
		Referred to HVIN, $T_A = 25^\circ\text{C}$, AMC0381R06	-900	± 240	900	
		Referred to HVIN, $T_A = 25^\circ\text{C}$, AMC0381R10	-1500	± 400	1500	
		Referred to HVIN, $T_A = 25^\circ\text{C}$, AMC0381R16	-2400	± 640	2400	
TCV_{OS}	Input offset thermal drift ⁽³⁾	Referred to SNSP, $V_{SNSP} = 0.25\text{V}$	-0.02	± 0.005	0.02	mV/ $^\circ\text{C}$
		Referred to HVIN, AMC0381R06	-12	± 3	12	
		Referred to HVIN, AMC0381R10	-20	± 5	20	
		Referred to HVIN, AMC0381R16	-32	± 8	32	
E_A	Attenuation error ⁽¹⁾	$T_A = 25^\circ\text{C}$	-0.25%	$\pm 0.02\%$	0.25%	
TCE_A	Attenuation error temperature drift ⁽⁴⁾		-40	± 20	40	ppm/ $^\circ\text{C}$
	Nonlinearity ⁽²⁾		-0.025%	$\pm 0.01\%$	0.025%	
	Output noise	$V_{IN} = \text{GND1}$, BW = 50kHz		160		μVrms
PSRR	Power-supply rejection ratio ⁽⁵⁾	VDD1 DC PSRR, $V_{SNSP} = 0.25\text{V}$, VDD1 from 3V to 5.5V		-77		dB
		VDD1 AC PSRR, $V_{SNSP} = 0.25\text{V}$, VDD1 with 10kHz / 100mV ripple		-49		
		VDD2 DC PSRR, $V_{SNSP} = 0.25\text{V}$, VDD2 from 3V to 5.5V		-100		
		VDD2 AC PSRR, $V_{SNSP} = 0.25\text{V}$, VDD2 with 10kHz / 100mV ripple		-62		
AC ACCURACY						
BW	Output bandwidth		120	145		kHz
THD	Total harmonic distortion	$V_{SNSP} = 1V_{PP}$, SNSN = GND1, $f_{IN} = 10\text{kHz}$		-80	-73	dB
SNR	Signal-to-noise ratio	$V_{SNSP} = 1V_{PP}$, SNSN = GND1, $f_{IN} = 1\text{kHz}$, BW = 10kHz	71	75		dB

6.9 Electrical Characteristics (continued)

minimum and maximum specifications apply from $T_A = -40^{\circ}\text{C}$ to $+125^{\circ}\text{C}$, $V_{DD1} = 3.0\text{V}$ to 5.5V , $V_{DD2} = 3.0\text{V}$ to 5.5V , $V_{REFIN} = 3.3\text{V}$, $V_{SNSP} = 0\text{V}$ to $+1\text{V}$, and $V_{SNSN} = 0\text{V}$; typical specifications are at $T_A = 25^{\circ}\text{C}$, $V_{DD1} = 5\text{V}$, $V_{DD2} = 3.3\text{V}$ (unless otherwise noted)

PARAMETER		TEST CONDITIONS	MIN	TYP	MAX	UNIT
SNR	Signal-to-noise ratio	$V_{SNSP} = 1V_{PP}$, $SNSN = \text{GND1}$, $f_{IN} = 10\text{kHz}$, $\text{BW} = 50\text{kHz}$		68		dB
POWER SUPPLY						
I_{DD1}	High-side supply current			4.3	5.6	mA
I_{DD2}	Low-side supply current			4.8	7.4	mA
V_{DD1UV}	High-side undervoltage detection threshold	VDD1 rising	2.5	2.6	2.7	V
		VDD1 falling	1.9	2.0	2.1	
V_{DD2UV}	Low-side undervoltage detection threshold	VDD2 rising	2.3	2.5	2.7	V
		VDD2 falling	1.9	2.05	2.2	

- The typical value includes one sigma statistical variation.
- Integral nonlinearity is defined as the maximum deviation from a straight line passing through the end-points of the ideal ADC transfer function expressed as number of LSBs or as a percent of the specified linear full-scale range FSR.
- Offset error drift is calculated using the box method, as described by the following equation:
 $TCE_O = (\text{value}_{MAX} - \text{value}_{MIN}) / \text{TempRange}$
- Attenuation error drift is calculated using the box method, as described by the following equation:
 $TCE_A (\text{ppm}) = ((\text{value}_{MAX} - \text{value}_{MIN}) / (\text{value} \times \text{TempRange})) \times 10^6$
- This parameter is referred to SNSP.

6.10 Switching Characteristics

over operating ambient temperature range (unless otherwise noted)

PARAMETER		TEST CONDITIONS	MIN	TYP	MAX	UNIT
t_r	Output signal rise time			2.6		μs
t_f	Output signal fall time			2.6		μs
	V_{SNSP} to V_{OUT} signal delay (50% – 10%)	Unfiltered output		1.6		μs
	V_{SNSP} to V_{OUT} signal delay (50% – 50%)	Unfiltered output		2.9	3.2	μs
	V_{SNSP} to V_{OUT} signal delay (50% – 90%)	Unfiltered output		4.3		μs
t_{AS}	Analog settling time	VDD1 step to 3.0V with $V_{DD2} \geq 3.0\text{V}$, to V_{OUT} valid, 0.1% settling		20	100	μs

6.11 Timing Diagram

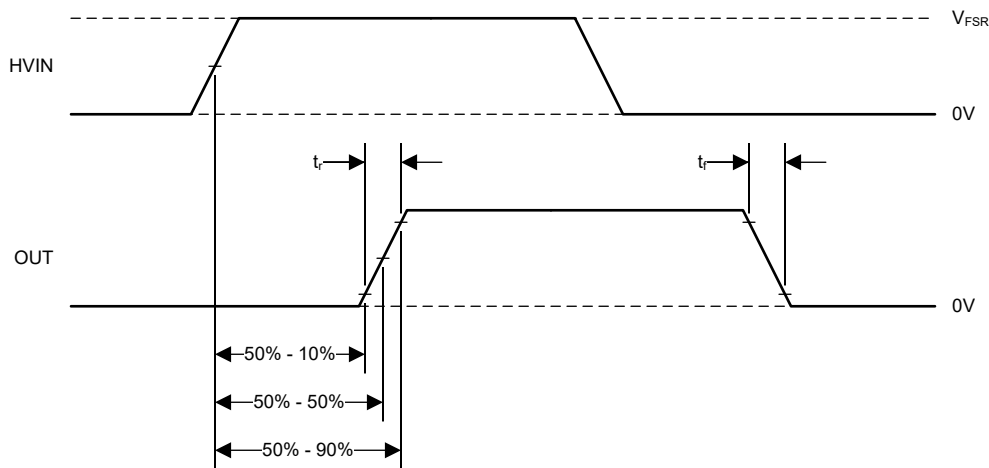

Figure 6-1. Rise, Fall, and Delay Time Definitions

6.12 Insulation Characteristics Curves

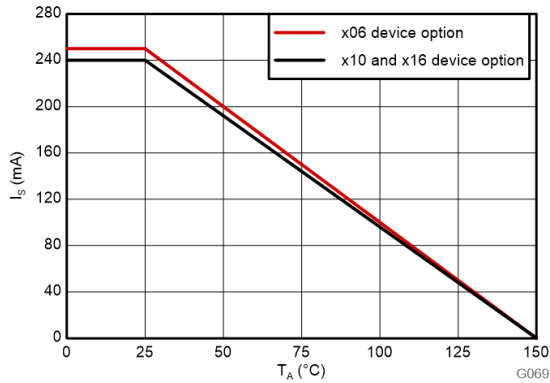

Figure 6-2. Thermal Derating Curve for Safety-Limiting Current per VDE

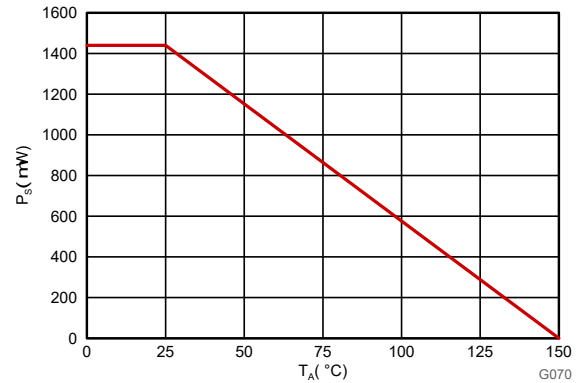
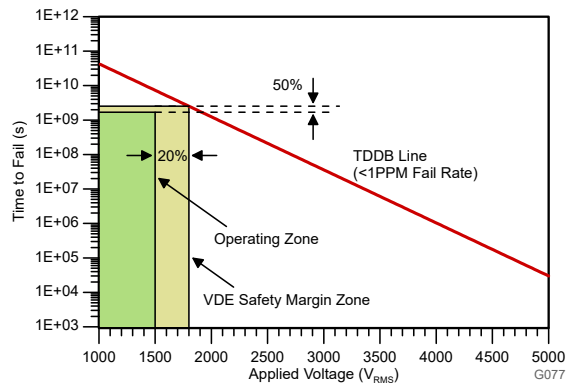

Figure 6-3. Thermal Derating Curve for Safety-Limiting Power per VDE



T_A up to 150°C, stress-voltage frequency = 60Hz, isolation working voltage = 1500V_{RMS}, projected operating lifetime ≥50 years

Figure 6-4. Reinforced Isolation Capacitor Lifetime Projection

6.13 Typical Characteristics

at VDD1 = 5V, VDD2 = 3.3V, SNSN = GND1, and $f_{IN} = 10\text{kHz}$ (unless otherwise noted)

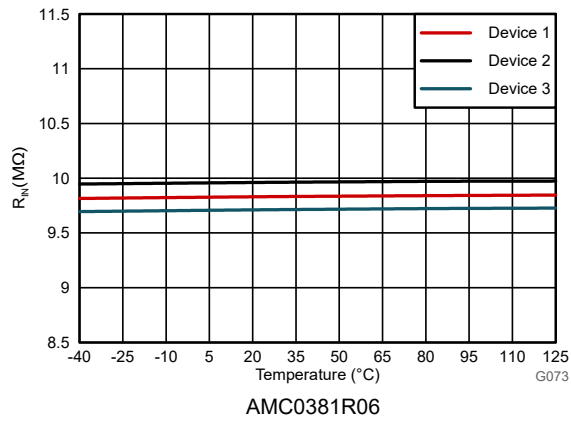

Figure 6-5. Input Resistance vs Temperature

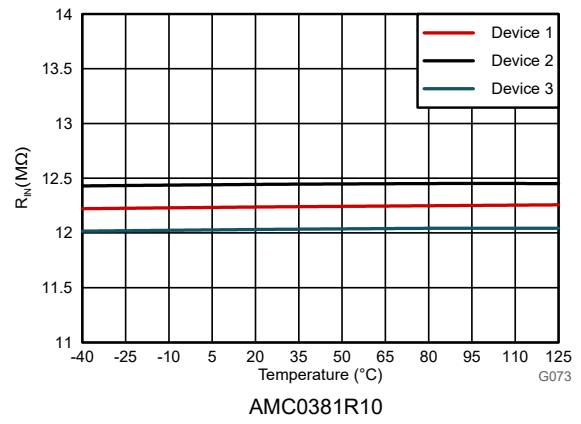

Figure 6-6. Input Resistance vs Temperature

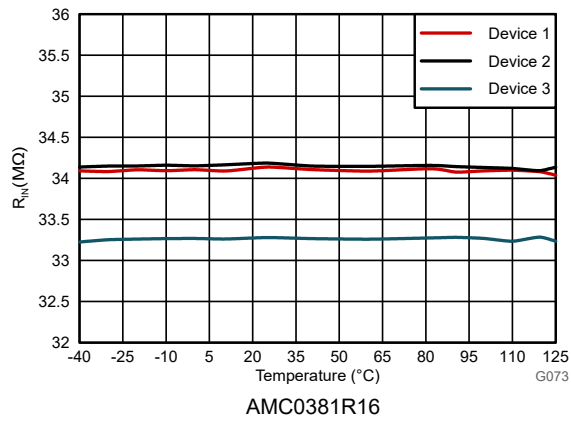

Figure 6-7. Input Resistance vs Temperature

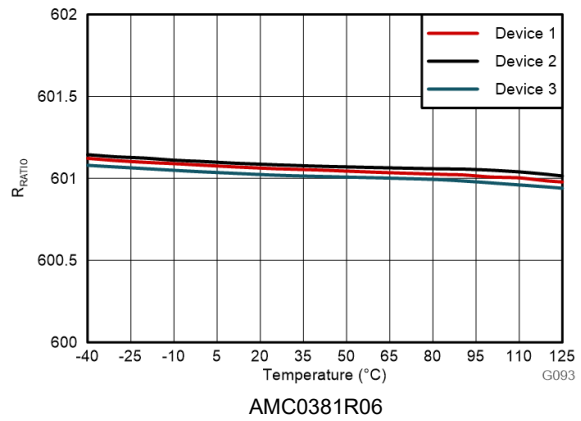

Figure 6-8. Divider Ratio vs Temperature

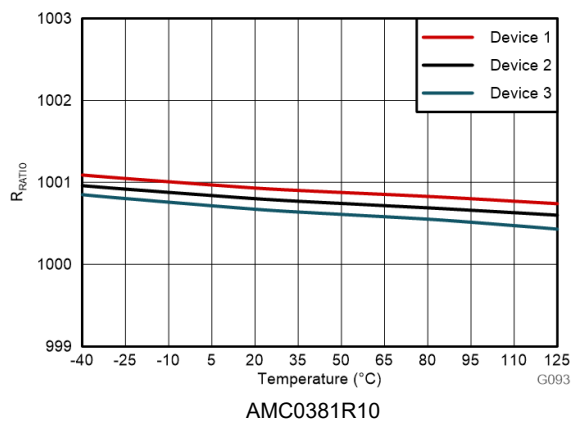

Figure 6-9. Divider Ratio vs Temperature

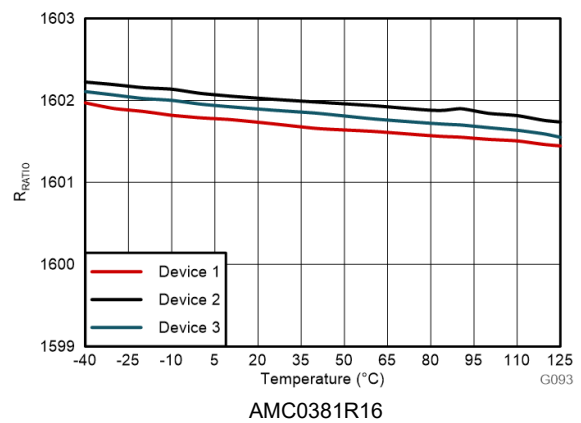
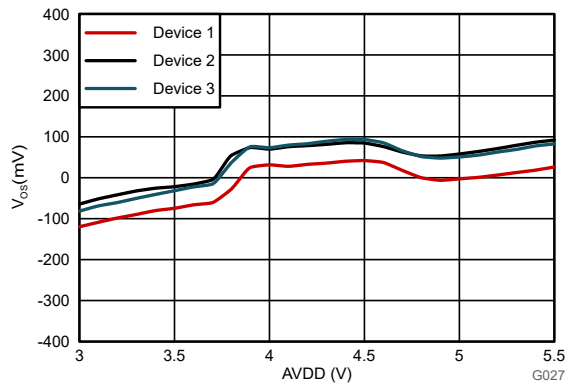

Figure 6-10. Divider Ratio vs Temperature

6.13 Typical Characteristics (continued)

at VDD1 = 5V, VDD2 = 3.3V, SNSN = GND1, and $f_{IN} = 10\text{kHz}$ (unless otherwise noted)



AMC0381R06

Figure 6-11. Input Offset Voltage vs High-Side Supply Voltage

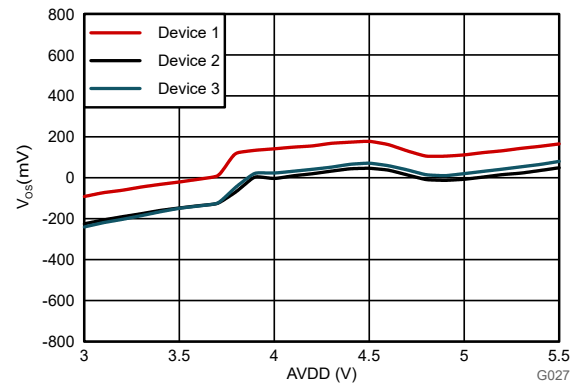

AMC0381R10

Figure 6-12. Input Offset Voltage vs High-Side Supply Voltage

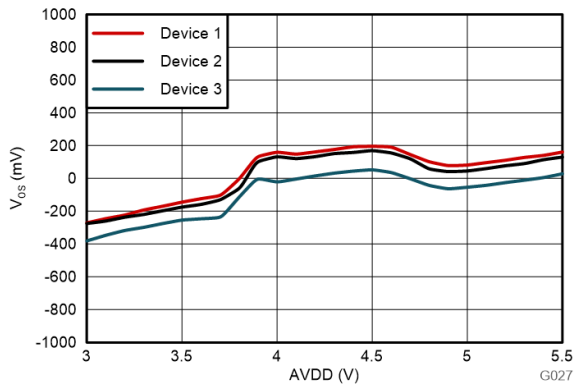

AMC0381R16

Figure 6-13. Input Offset Voltage vs High-Side Supply Voltage

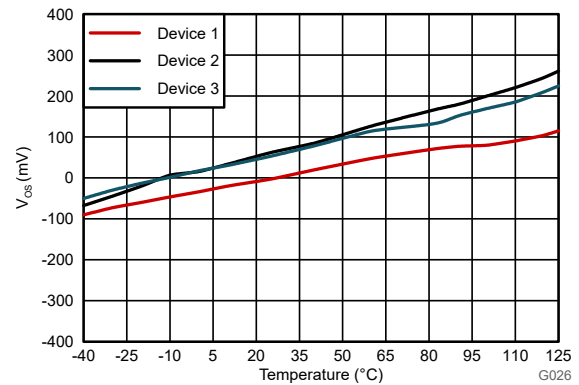

AMC0381R06

Figure 6-14. Input Offset Voltage vs Temperature

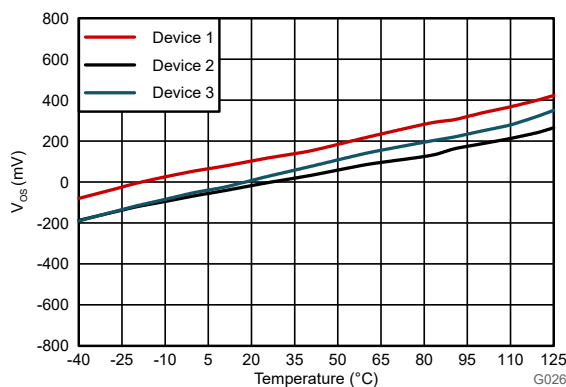

AMC0381R10

Figure 6-15. Input Offset Voltage vs Temperature

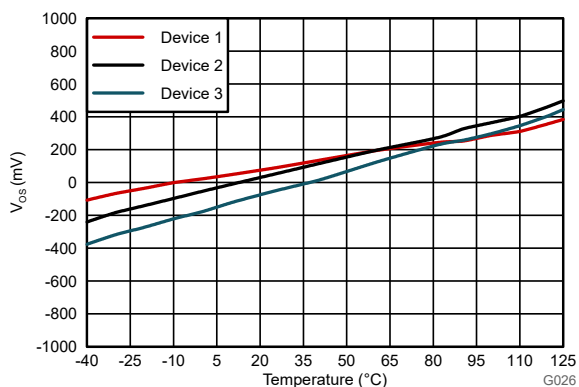

AMC0381R16

Figure 6-16. Input Offset Voltage vs Temperature

6.13 Typical Characteristics (continued)

at VDD1 = 5V, VDD2 = 3.3V, SNSN = GND1, and $f_{IN} = 10\text{kHz}$ (unless otherwise noted)

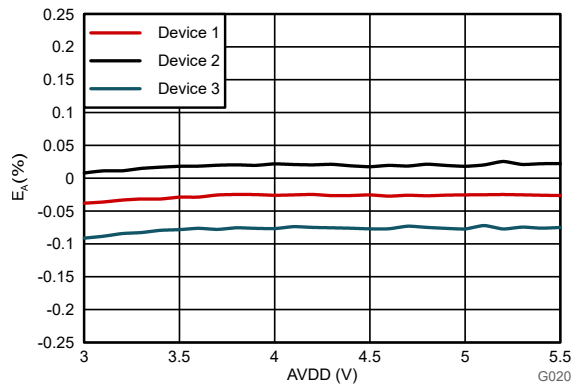

Figure 6-17. Attenuation Error vs High-Side Supply Voltage

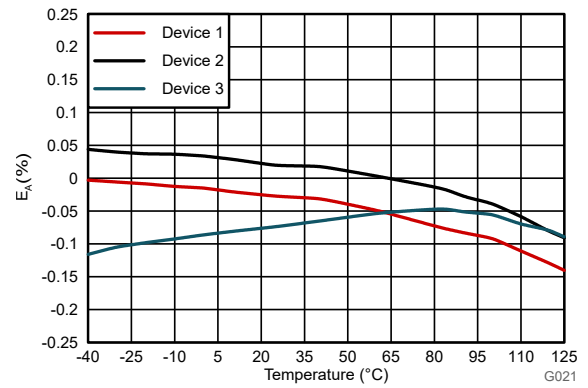

Figure 6-18. Attenuation Error vs Temperature

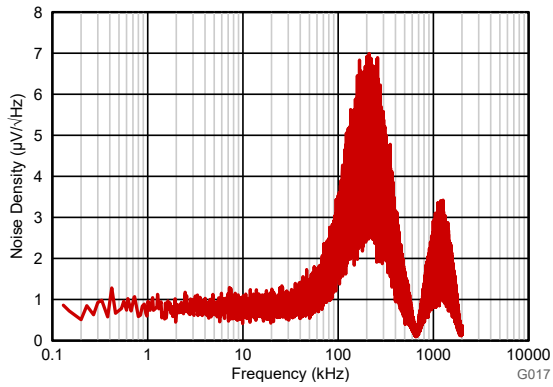

Figure 6-19. Input-Referred Noise Density vs Frequency

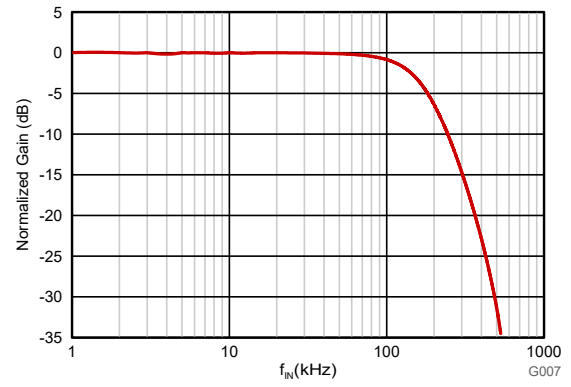

Figure 6-20. Normalized Gain vs Input Frequency

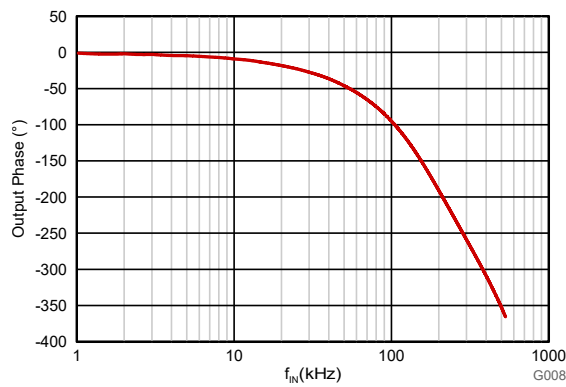

Figure 6-21. Output Phase vs Input Frequency

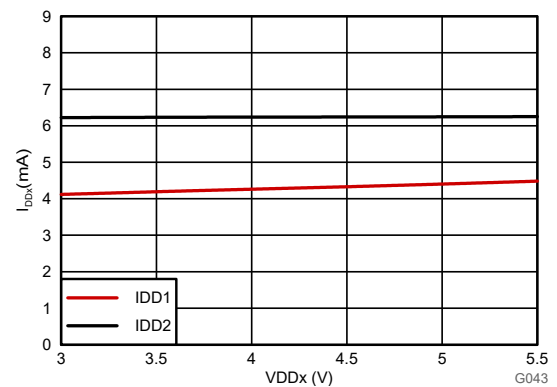

Figure 6-22. Supply Current vs Supply Voltage

6.13 Typical Characteristics (continued)

at VDD1 = 5V, VDD2 = 3.3V, SNSN = GND1, and f_{IN} = 10kHz (unless otherwise noted)

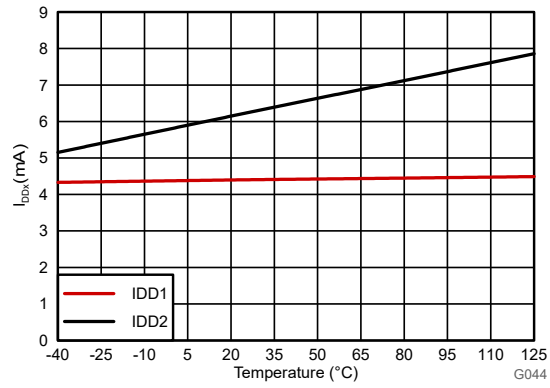

Figure 6-23. Supply Current vs Temperature

7 Detailed Description

7.1 Overview

The AMC0381R is a precision, galvanically isolated amplifier with a high-voltage DC, high impedance input, and single-ended ratiometric output. The input stage of the device drives a second-order, delta-sigma ($\Delta\Sigma$) modulator. The modulator converts the analog input signal into a digital bitstream that is transferred across the isolation barrier that separates the high-side from the low-side.

On the low-side, the received bitstream is processed by an analog filter that outputs a GND2-referenced, single-ended signal at the OUT pin. This single-ended output signal is proportional to the input signal. The full-scale output voltage of the isolated amplifier is equal to the voltage applied to the REFIN pin.

The SiO₂-based, capacitive isolation barrier supports a high level of magnetic field immunity, as described in the [ISO72x Digital Isolator Magnetic-Field Immunity application note](#). The digital modulation used in the AMC0381R transmits data across the isolation barrier. This modulation, and the isolation barrier characteristics, result in high reliability and high common-mode transient immunity.

7.2 Functional Block Diagram

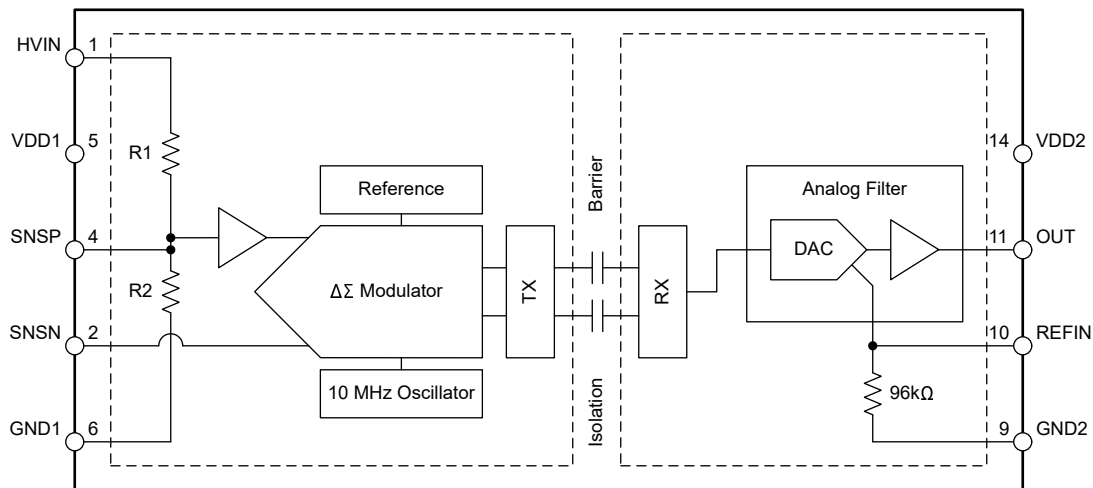

7.3 Feature Description

7.3.1 Analog Input

The resistive divider at the input of the AMC0381R scales down the voltage applied to the HVIN pin to a 1V linear full-scale level. This signal is available on the SNSP pin, which is also the input of the analog signal chain.

The high-impedance input buffer on the SNSP pin feeds a second-order, switched-capacitor, feed-forward $\Delta\Sigma$ modulator. The modulator converts the analog signal into a bitstream that is transferred across the isolation barrier, as described in the [Isolation Channel Signal Transmission](#) section.

7.3.2 Isolation Channel Signal Transmission

As shown in [Figure 7-1](#), the AMC0381R uses an on-off keying (OOK) modulation scheme to transmit the modulator output bitstream across the SiO₂-based isolation barrier. The transmit driver (TX) is illustrated in the [Functional Block Diagram](#). TX transmits an internally generated, high-frequency carrier across the isolation barrier to represent a digital *one*. However, TX does not send a signal to represent a digital *zero*. The nominal frequency of the carrier used inside the AMC0381R is 480MHz.

The receiver (RX) on the other side of the isolation barrier recovers and demodulates the signal and provides the input to the analog filter. The AMC0381R transmission channel is optimized to achieve the highest level of common-mode transient immunity (CMTI) and the lowest level of radiated emissions. The high-frequency carrier and RX/TX buffer switching cause these emissions.

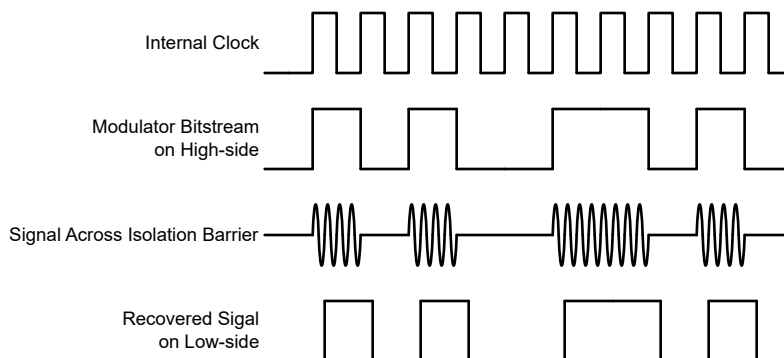

Figure 7-1. OOK-Based Modulation Scheme

7.3.3 Analog Output

The AMC0381R provides a single-ended analog output voltage proportional to the input voltage. The output is referred to GND2 and is galvanically isolated from the input of the device. The output is designed to connect directly to the input of an ADC.

The full-scale output voltage is set by the REFIN pin. For any input voltage within the specified linear input range, the device outputs a voltage equal to:

$$V_{OUT} = V_{HVIN} / V_{Clipping} \times V_{REFIN} \quad (1)$$

Connect REFIN to the same reference voltage as the ADC to match the ADC dynamic input voltage range. With a shared reference voltage, the ADC outputs a positive full-scale code when the clipping voltage is applied to the input of the AMC0381R. The output buffer requires a minimum headroom of 150mV against GND2 for linear operation. Therefore, the device shows non-linear behavior for input voltages near 0V.

Calculate the minimum input voltage for linear operation as follows:

$$V_{HVIN, MIN} = (150mV \times V_{Clipping}) / V_{REFIN} \quad (2)$$

For example, the minimum linear input voltage for the with a clipping voltage of 1281V and $V_{REFIN} = 5V$, is 38.4V.

The device is linear within the specified linear full-scale range. Beyond the linear full-scale range, the output continues to follow the input, but with reduced linearity performance. The output clips when the input voltage reaches the clipping voltage. Figure 7-2 shows the input-to-output transfer characteristic.

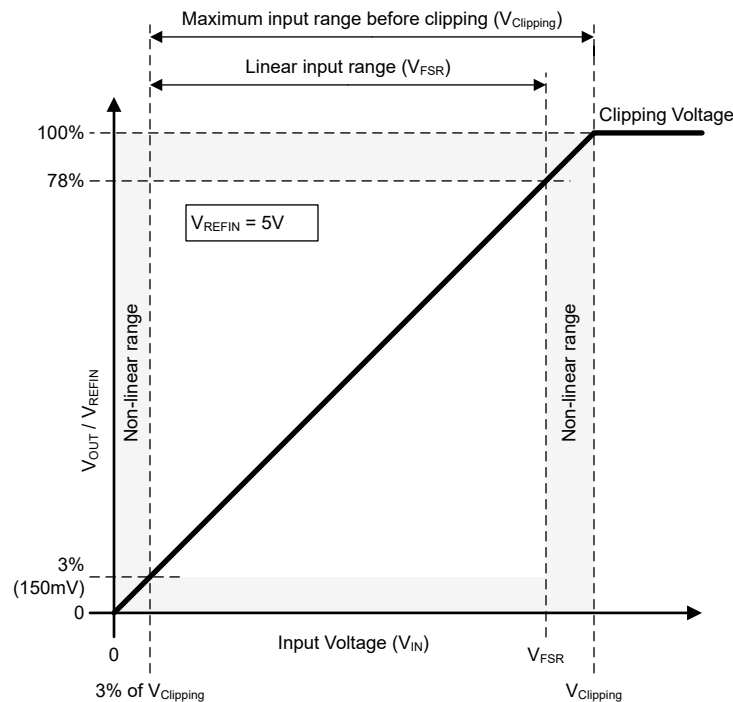

Figure 7-2. Input-to-Output Transfer Curve of the AMC0381R

7.4 Device Functional Modes

The AMC0381R operates in one of the following states:

- Off-state: The low-side supply (VDD2) is below the $VDD2_{UV}$ threshold. The device is not responsive. OUT is in Hi-Z state. Internally, OUT is clamped to VDD2 and GND2 by ESD protection diodes.
- Missing high-side supply: The low-side of the device (VDD2) is supplied and within recommended operating conditions. The high-side supply (VDD1) is below the $VDD1_{UV}$ threshold. The OUT pin is driven to GND2.
- Analog input overrange (positive full-scale input): VDD1 and VDD2 are within recommended operating conditions but the analog input voltage V_{IN} is above the maximum clipping voltage $V_{Clipping, MAX}$. The device outputs V_{REFIN} at the OUT pin.
- Analog input underrange (negative full-scale input): VDD1 and VDD2 are within recommended operating conditions but the analog input voltage V_{IN} is below the minimum clipping voltage $V_{Clipping, MIN}$. The OUT pin is driven to GND2.
- Normal operation: VDD1, VDD2, and V_{IN} are within the recommended operating conditions. The device outputs a voltage that is proportional to the input voltage.

Table 7-1 lists the operating modes.

Table 7-1. Device Operational Modes

OPERATING CONDITION	VDD1	VDD2	V_{IN}	DEVICE RESPONSE
Off	Don't care	$VDD2 < VDD2_{UV}$	Don't care	OUT is in Hi-Z state. Internally, OUT is clamped to VDD2 and GND2 by ESD protection diodes.
Missing high-side supply	$VDD1 < VDD1_{UV}$	Valid ⁽¹⁾	Don't care	The OUT pin is driven to GND2.
Input overrange	Valid ⁽¹⁾	Valid ⁽¹⁾	$V_{IN} > V_{Clipping, MAX}$	The device outputs V_{REFIN} at the OUT pin.
Input underrange	Valid ⁽¹⁾	Valid ⁽¹⁾	$V_{IN} < V_{Clipping, MIN}$	The OUT pin is driven to GND2.
Normal operation	Valid ⁽¹⁾	Valid ⁽¹⁾	Valid ⁽¹⁾	The device outputs a voltage that is proportional to the input voltage.

(1) *Valid* denotes operation within the recommended operating conditions.

8 Application and Implementation

Note

Information in the following applications sections is not part of the TI component specification, and TI does not warrant its accuracy or completeness. TI's customers are responsible for determining suitability of components for their purposes, as well as validating and testing their design implementation to confirm system functionality.

8.1 Application Information

Industrial power systems such as motor drives are divided into two or more voltage domains that are galvanically isolated from each other. For example, the high-voltage domain includes the AC grid, DC link, and power stage for driving the motor. The low-voltage includes the system controller and human interface. The controller measures the value of the DC link voltage while remaining galvanically isolated from the high-voltage side for safety reasons. With the high-impedance input and galvanically isolated output, the AMC0381R enables this measurement.

8.2 Typical Application

The following image illustrates a simplified schematic of an AC inverter for a three-phase motor drive. The AMC0381R is used for DC link voltage sensing. In the power domain, the AMC0381R is connected directly between DC(+) and DC(-). The low-side gate driver supply is regulated to a 5V level to power the high-voltage side of the AMC0381R. In the signal domain, on the opposite side of the isolation barrier, the AMC0381R outputs a voltage proportional to the DC link voltage.

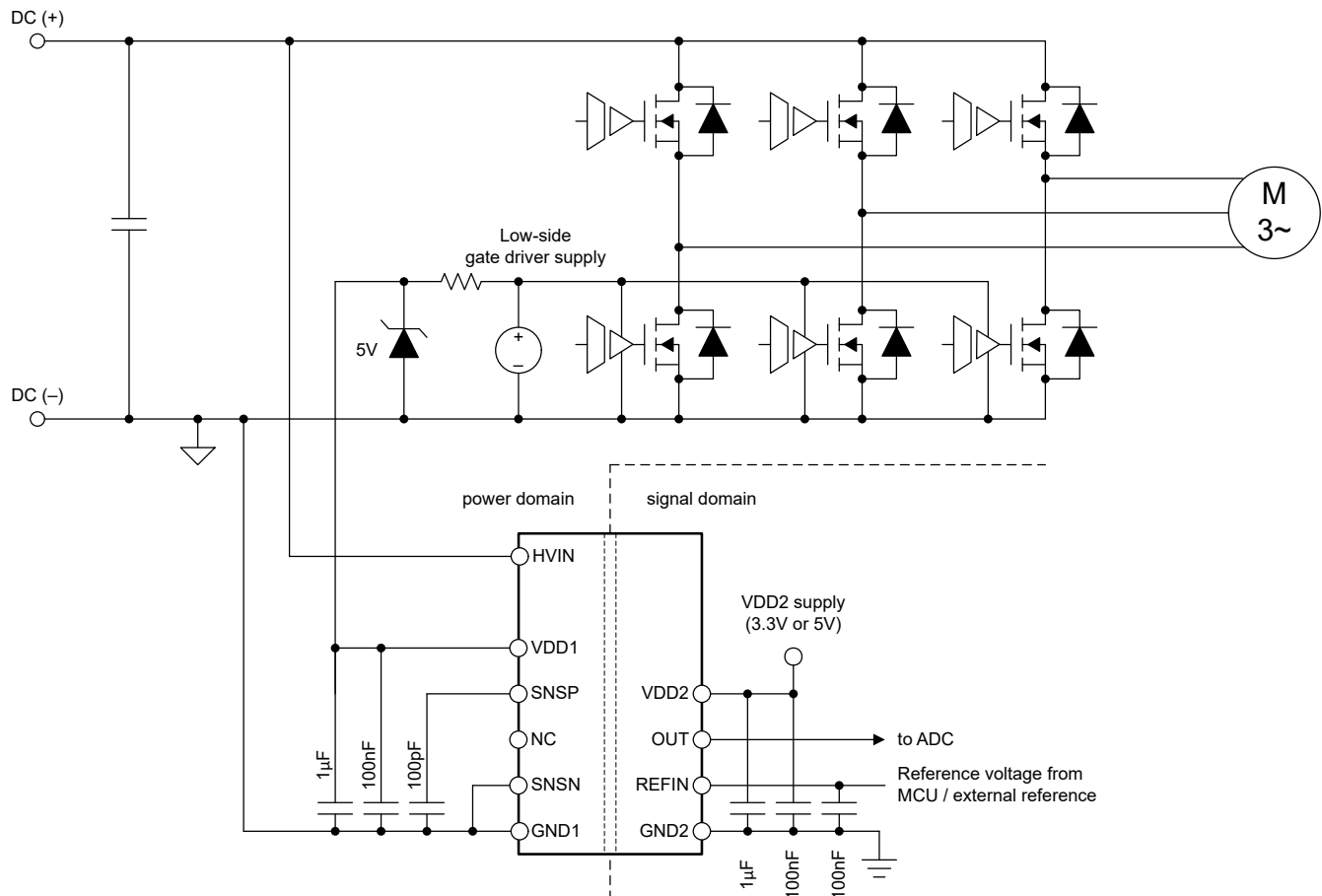

Figure 8-1. Using the AMC0381R in a Typical Application

8.2.1 Design Requirements

Table 8-1 lists the parameters for this typical application.

Table 8-1. Design Requirements

PARAMETER	VALUE
DC link voltage	450V (maximum)
High-side supply voltage	5V
Low-side supply voltage	3.3V

8.2.2 Detailed Design Procedure

In this design example the maximum DC link voltage is 450V. For best measurement resolution, select a device from the AMC0381R family with a linear input range that closest matches the peak input voltage. The AMC0381R06 supports a linear input range of 600V and is a good fit for the application. Connect HVIN directly to DC (+) and GND1 to DC (-); see the diagram in the [Typical Application](#) section.

8.2.2.1 Input Filter Design

Connect a filter capacitor to the SNSP pin to improve signal-to-noise performance of the signal path. Input noise with a frequency close to the $\Delta\Sigma$ modulator sampling frequency (typically 10MHz) is folded back into the low-frequency range by the modulator. The purpose of the RC filter is to attenuate high-frequency noise below the desired noise level of the measurement. In practice, a cutoff frequency that is two orders of magnitude lower than the modulator frequency yields good results.

The cutoff frequency of the input filter is determined by the internal sensing resistor R2 and the external filter capacitor C5. The cutoff frequency is calculated as $1 / (2 \times \pi \times R2 \times C5)$.

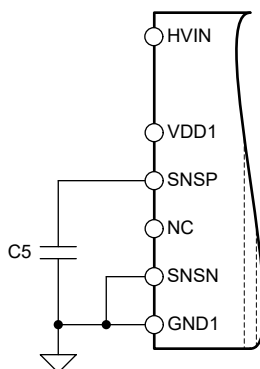

Figure 8-2. Input Filter

8.2.2.2 Connecting the REFIN Pin

The reference input has a finite input impedance as shown in the [Functional Block Diagram](#). Consider this impedance when driving the REFIN pin from a high-impedance source. Connect a 100nF capacitor from REFIN to GND2 to filter out high-frequency noise at the reference input. [Figure 8-3](#) shows different options for connecting the REFIN pin.

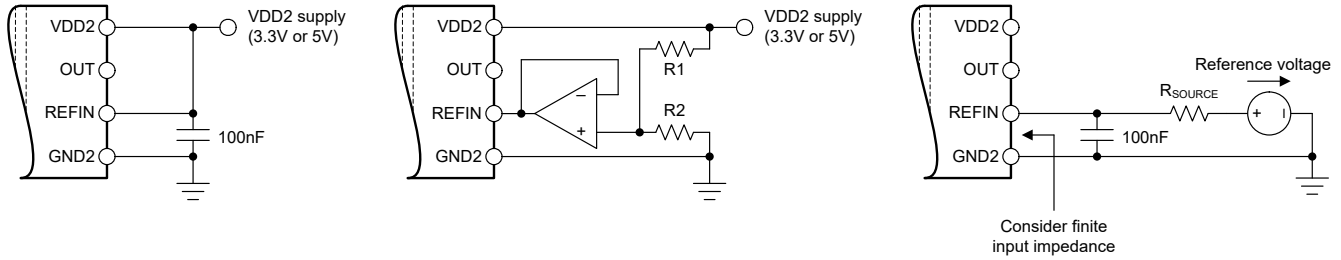

Figure 8-3. Connecting the REFIN Pin

In the first example, REFIN is shorted to VDD2. In the second example, V_{REFIN} is derived from VDD2 through a buffered resistive divider. In the third example, an external voltage source drives the reference input pin.

8.2.3 Application Curve

Figure 8-4 shows the typical full-scale step response of the AMC0381R.

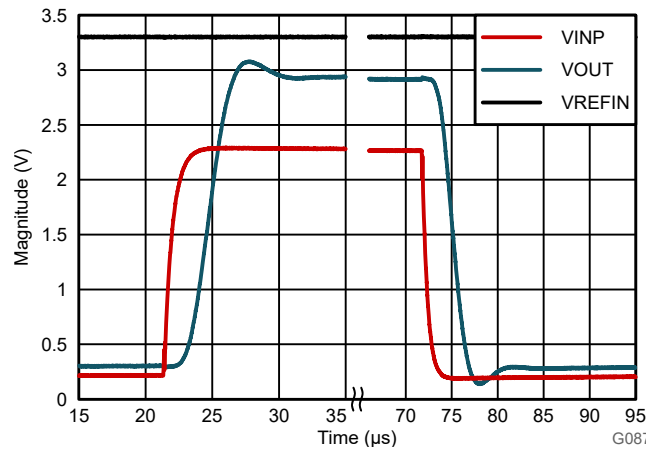

Figure 8-4. Step Response of the AMC0381R

8.3 Best Design Practices

Avoid any kind of leakage current between the HVIN and SNSP pin. Leakage current potentially introduces significant measurement error. See the [Layout Example](#) for layout recommendations.

8.4 Power Supply Recommendations

In a typical application, the high-side power supply (VDD1) for the AMC0381R is generated from the low-side supply (VDD2) by an isolated DC/DC converter. A low-cost option is based on the push-pull driver [SN6501](#) and a transformer that supports the desired isolation voltage ratings.

The AMC0381R does not require any specific power-up sequencing. The high-side power supply (VDD1) is decoupled with a low-ESR, 100nF capacitor (C1) parallel to a low-ESR, 1 μ F capacitor (C2). The low-side power supply (VDD2) is equally decoupled with a low-ESR, 100nF capacitor (C3) parallel to a low-ESR, 1 μ F capacitor (C4). Place all four capacitors (C1, C2, C3, and C4) as close to the device as possible. [Figure 8-5](#) shows a decoupling diagram for the AMC0381R.

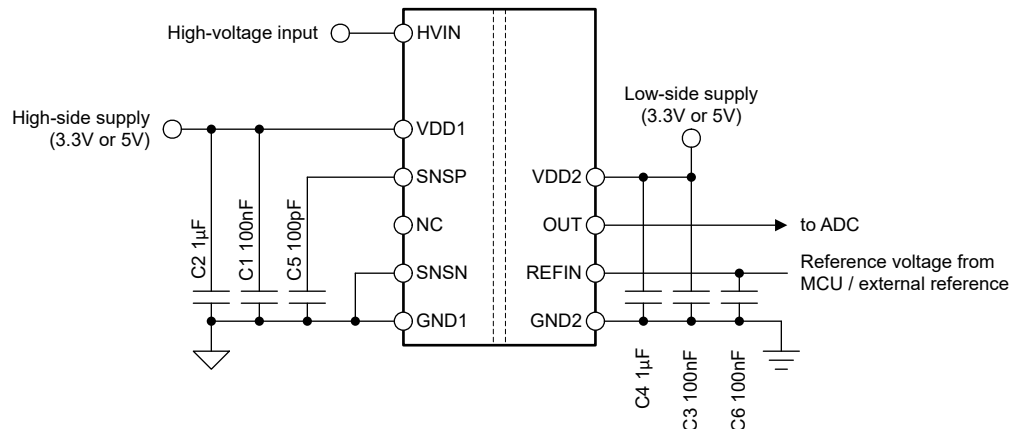

Figure 8-5. Decoupling of the AMC0381R

Verify capacitors provide adequate *effective* capacitance under the applicable DC bias conditions experienced in the application. Multilayer ceramic capacitors (MLCC) typically exhibit only a fraction of the nominal capacitance under real-world conditions. Consider this factor when selecting these capacitors. This issue is especially acute in low-profile capacitors, where the dielectric field strength is higher than in taller components. Reputable capacitor manufacturers provide capacitance versus DC bias curves that greatly simplify component selection.

8.5 Layout

8.5.1 Layout Guidelines

The *Layout Example* section details a layout recommendation with the critical placement of the decoupling capacitors (as close as possible to the AMC0381R supply pins). This example also depicts the placement of other components required by the device.

8.5.2 Layout Example

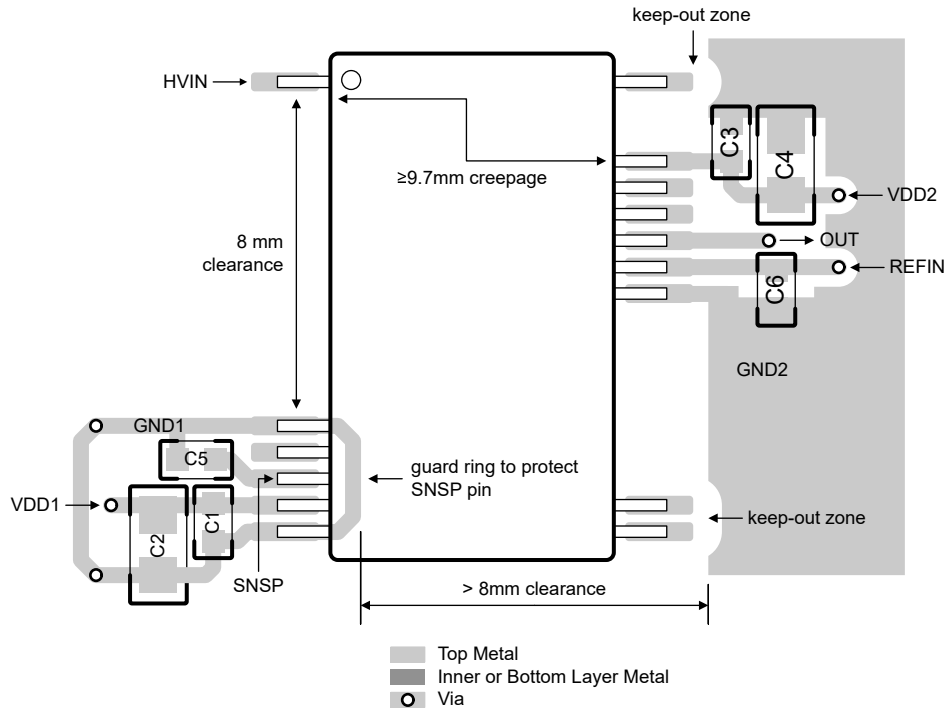

Figure 8-6. Recommended Layout of the AMC0381R

9 Device and Documentation Support

9.1 Documentation Support

9.1.1 Related Documentation

For related documentation, see the following:

- Texas Instruments, [Isolation Glossary application note](#)
- Texas Instruments, [Semiconductor and IC Package Thermal Metrics application note](#)
- Texas Instruments, [ISO72x Digital Isolator Magnetic-Field Immunity application note](#)
- Texas Instruments, [Isolated Amplifier Voltage Sensing Excel Calculator design tool](#)

9.2 Receiving Notification of Documentation Updates

To receive notification of documentation updates, navigate to the device product folder on ti.com. Click on *Notifications* to register and receive a weekly digest of any product information that has changed. For change details, review the revision history included in any revised document.

9.3 Support Resources

[TI E2E™ support forums](#) are an engineer's go-to source for fast, verified answers and design help — straight from the experts. Search existing answers or ask your own question to get the quick design help you need.

Linked content is provided "AS IS" by the respective contributors. They do not constitute TI specifications and do not necessarily reflect TI's views; see TI's [Terms of Use](#).

9.4 Trademarks

TI E2E™ is a trademark of Texas Instruments.

All trademarks are the property of their respective owners.

9.5 Electrostatic Discharge Caution



This integrated circuit can be damaged by ESD. Texas Instruments recommends that all integrated circuits be handled with appropriate precautions. Failure to observe proper handling and installation procedures can cause damage.

ESD damage can range from subtle performance degradation to complete device failure. Precision integrated circuits may be more susceptible to damage because very small parametric changes could cause the device not to meet its published specifications.

9.6 Glossary

[TI Glossary](#) This glossary lists and explains terms, acronyms, and definitions.

10 Revision History

NOTE: Page numbers for previous revisions may differ from page numbers in the current version.

DATE	REVISION	NOTES
November 2025	*	Initial Release

11 Mechanical, Packaging, and Orderable Information

The following pages include mechanical, packaging, and orderable information. This information is the most current data available for the designated devices. This data is subject to change without notice and revision of this document. For browser-based versions of this data sheet, refer to the left-hand navigation.

PACKAGING INFORMATION

Orderable part number	Status (1)	Material type (2)	Package Pins	Package qty Carrier	RoHS (3)	Lead finish/ Ball material (4)	MSL rating/ Peak reflow (5)	Op temp (°C)	Part marking (6)
AMC0381R06DFXR	Active	Production	SSOP (DFX) 15	750 LARGE T&R	Yes	NIPDAU	Level-3-260C-168 HR	-40 to 125	AMC0381R06
AMC0381R10DFXR	Active	Production	SSOP (DFX) 15	750 LARGE T&R	Yes	NIPDAU	Level-3-260C-168 HR	-40 to 125	AMC0381R10
AMC0381R16DFXR	Active	Production	SSOP (DFX) 15	750 LARGE T&R	Yes	NIPDAU	Level-3-260C-168 HR	-40 to 125	AMC0381R16

(1) **Status:** For more details on status, see our [product life cycle](#).

(2) **Material type:** When designated, preproduction parts are prototypes/experimental devices, and are not yet approved or released for full production. Testing and final process, including without limitation quality assurance, reliability performance testing, and/or process qualification, may not yet be complete, and this item is subject to further changes or possible discontinuation. If available for ordering, purchases will be subject to an additional waiver at checkout, and are intended for early internal evaluation purposes only. These items are sold without warranties of any kind.

(3) **RoHS values:** Yes, No, RoHS Exempt. See the [TI RoHS Statement](#) for additional information and value definition.

(4) **Lead finish/Ball material:** Parts may have multiple material finish options. Finish options are separated by a vertical ruled line. Lead finish/Ball material values may wrap to two lines if the finish value exceeds the maximum column width.

(5) **MSL rating/Peak reflow:** The moisture sensitivity level ratings and peak solder (reflow) temperatures. In the event that a part has multiple moisture sensitivity ratings, only the lowest level per JEDEC standards is shown. Refer to the shipping label for the actual reflow temperature that will be used to mount the part to the printed circuit board.

(6) **Part marking:** There may be an additional marking, which relates to the logo, the lot trace code information, or the environmental category of the part.

Multiple part markings will be inside parentheses. Only one part marking contained in parentheses and separated by a "-" will appear on a part. If a line is indented then it is a continuation of the previous line and the two combined represent the entire part marking for that device.

Important Information and Disclaimer: The information provided on this page represents TI's knowledge and belief as of the date that it is provided. TI bases its knowledge and belief on information provided by third parties, and makes no representation or warranty as to the accuracy of such information. Efforts are underway to better integrate information from third parties. TI has taken and continues to take reasonable steps to provide representative and accurate information but may not have conducted destructive testing or chemical analysis on incoming materials and chemicals. TI and TI suppliers consider certain information to be proprietary, and thus CAS numbers and other limited information may not be available for release.

In no event shall TI's liability arising out of such information exceed the total purchase price of the TI part(s) at issue in this document sold by TI to Customer on an annual basis.

OTHER QUALIFIED VERSIONS OF AMC0381R :

- Automotive : [AMC0381R-Q1](#)

NOTE: Qualified Version Definitions:

- Automotive - Q100 devices qualified for high-reliability automotive applications targeting zero defects

TAPE AND REEL INFORMATION

QUADRANT ASSIGNMENTS FOR PIN 1 ORIENTATION IN TAPE

*All dimensions are nominal

Device	Package Type	Package Drawing	Pins	SPQ	Reel Diameter (mm)	Reel Width W1 (mm)	A0 (mm)	B0 (mm)	K0 (mm)	P1 (mm)	W (mm)	Pin1 Quadrant
AMC0381R06DFXR	SSOP	DFX	15	750	330.0	24.4	10.85	13.4	4.0	16.0	24.0	Q1
AMC0381R10DFXR	SSOP	DFX	15	750	330.0	24.4	10.85	13.4	4.0	16.0	24.0	Q1
AMC0381R16DFXR	SSOP	DFX	15	750	330.0	24.4	10.85	13.4	4.0	16.0	24.0	Q1

TAPE AND REEL BOX DIMENSIONS

*All dimensions are nominal

Device	Package Type	Package Drawing	Pins	SPQ	Length (mm)	Width (mm)	Height (mm)
AMC0381R06DFXR	SSOP	DFX	15	750	350.0	350.0	43.0
AMC0381R10DFXR	SSOP	DFX	15	750	350.0	350.0	43.0
AMC0381R16DFXR	SSOP	DFX	15	750	350.0	350.0	43.0

DFX0015A



PACKAGE OUTLINE

SSOP - 3.55 mm max height

SMALL OUTLINE PACKAGE

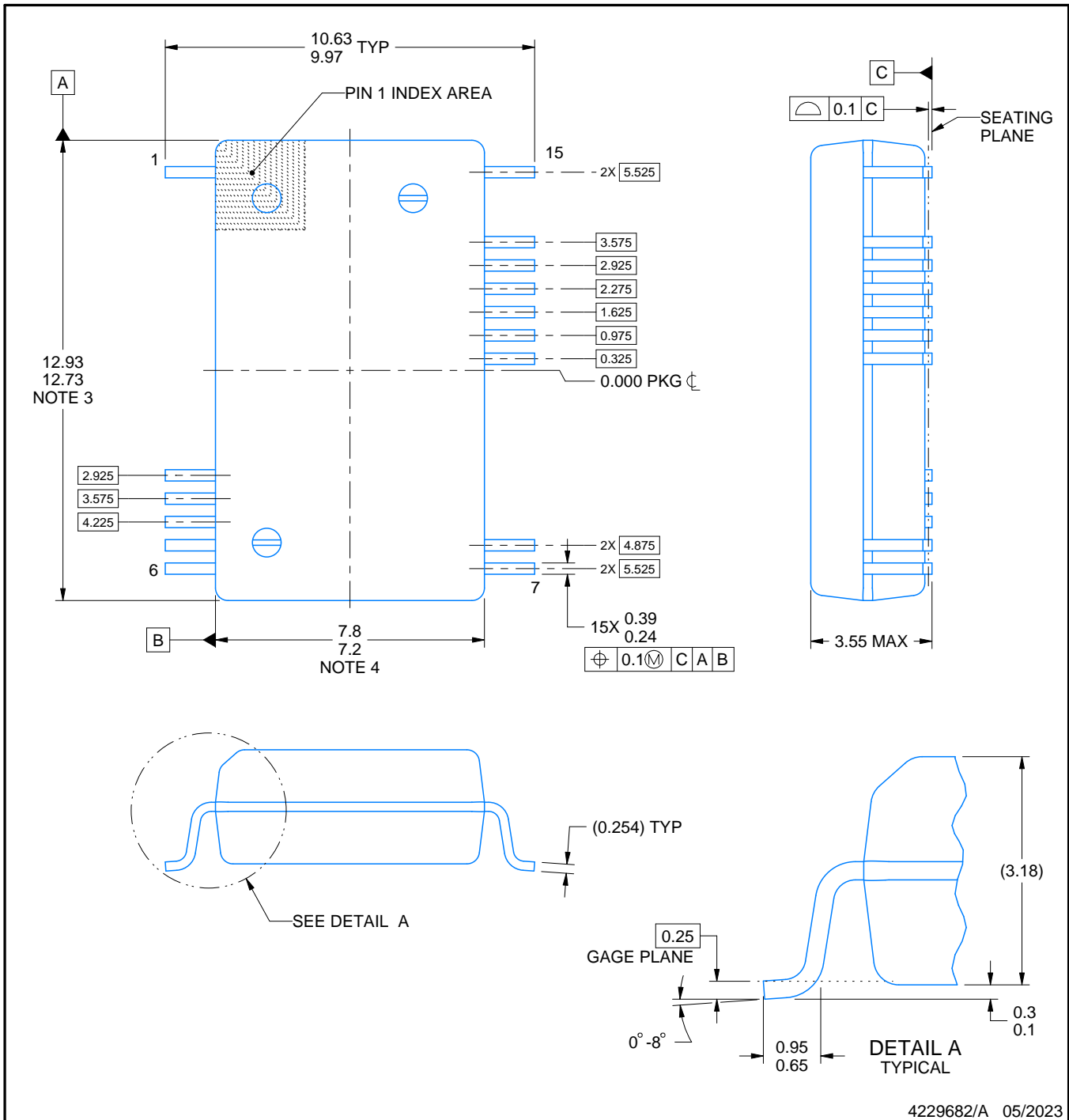

4229682/A 05/2023

NOTES:

1. All linear dimensions are in millimeters. Any dimensions in parenthesis are for reference only. Dimensioning and tolerancing per ASME Y14.5M.
2. This drawing is subject to change without notice.
3. This dimension does not include mold flash, protrusions, or gate burrs. Mold flash, protrusions, or gate burrs shall not exceed 0.15 mm per side.
4. This dimension does not include interlead flash. Interlead flash shall not exceed 0.25 mm per side.

EXAMPLE BOARD LAYOUT

DFX0015A

SSOP - 3.55 mm max height

SMALL OUTLINE PACKAGE

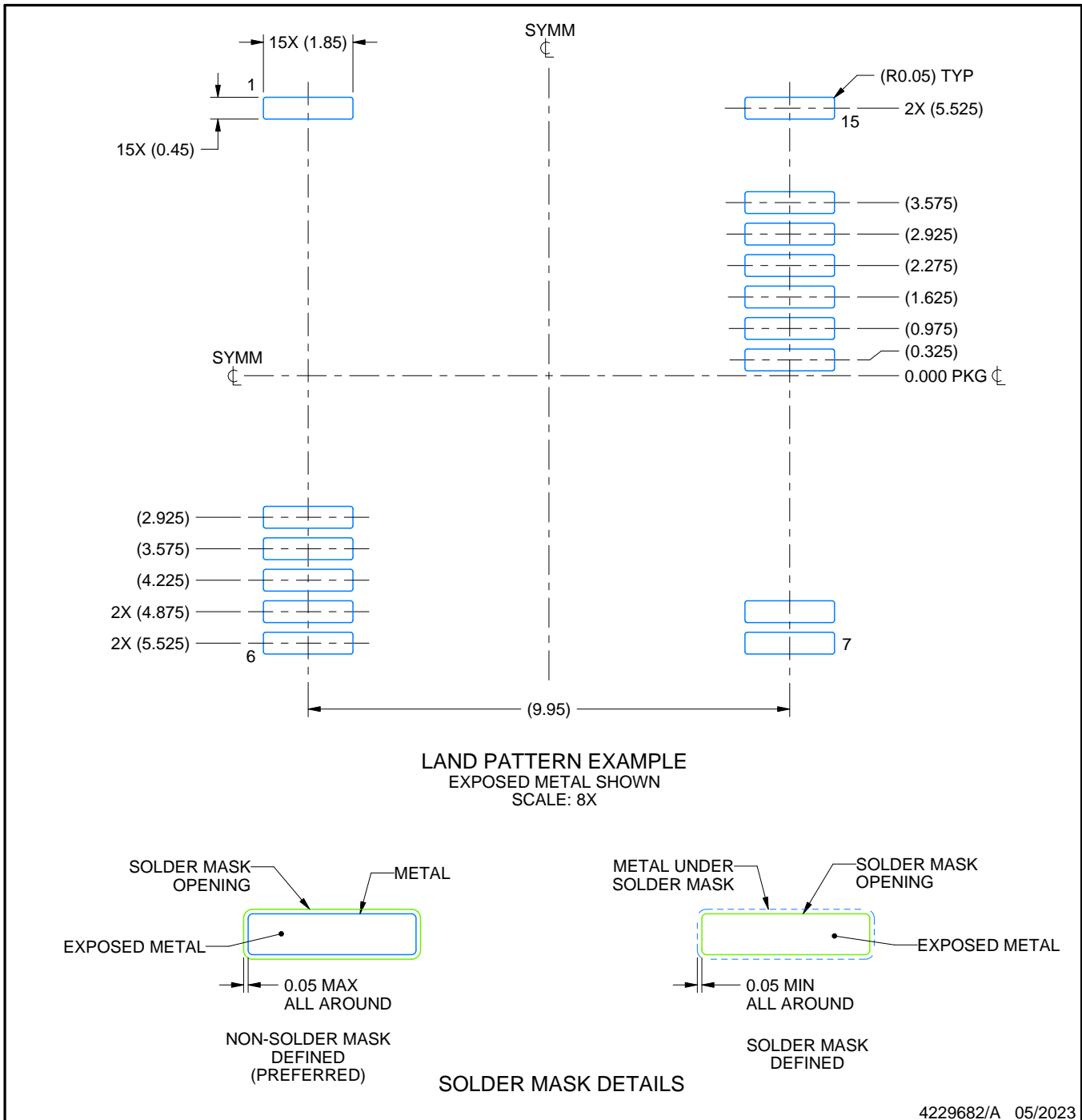

NOTES: (continued)

5. Publication IPC-7351 may have alternate designs.
6. Solder mask tolerances between and around signal pads can vary based on board fabrication site.

EXAMPLE STENCIL DESIGN

DFX0015A

SSOP - 3.55 mm max height

SMALL OUTLINE PACKAGE

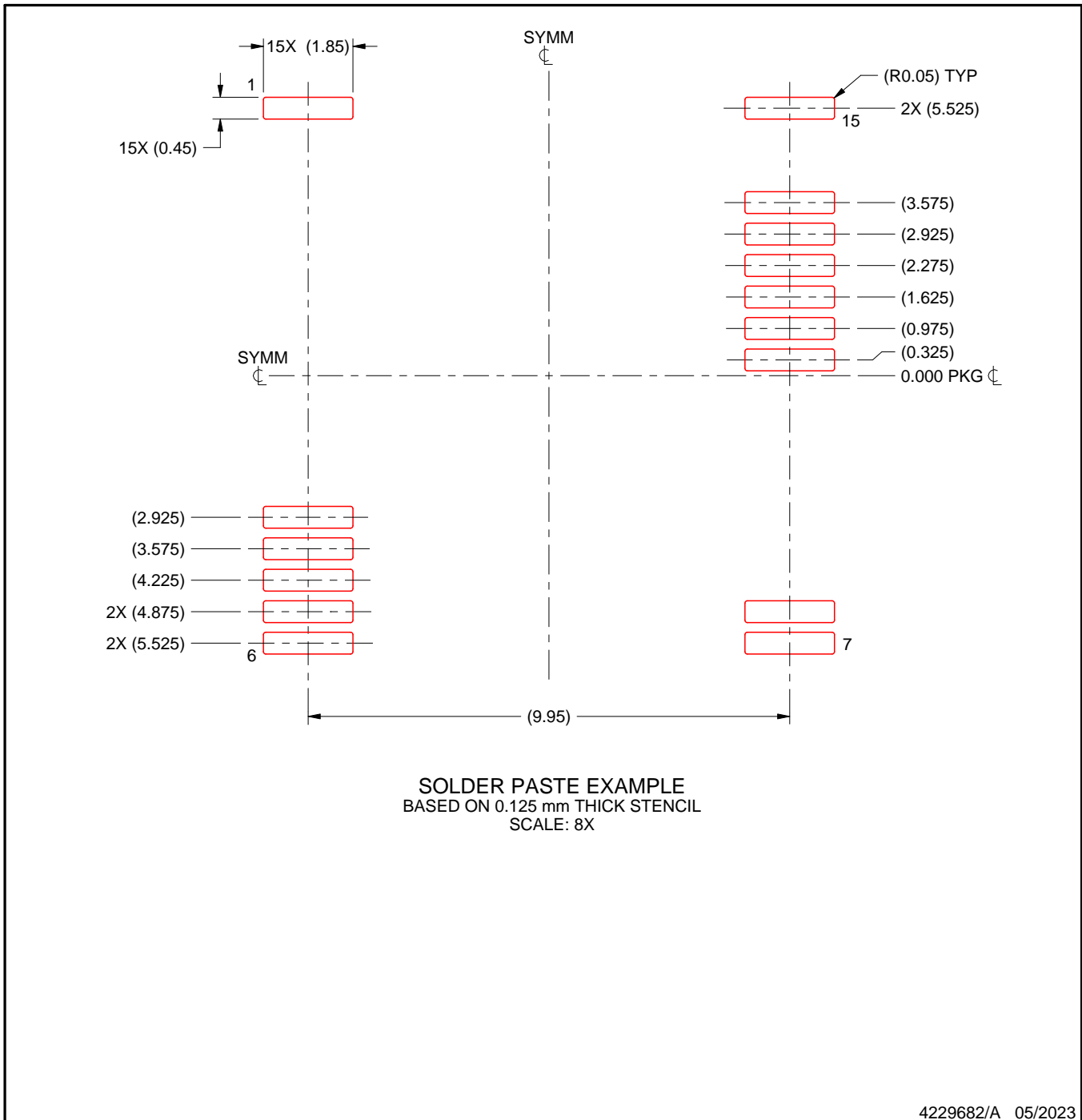

NOTES: (continued)

- 7. Laser cutting apertures with trapezoidal walls and rounded corners may offer better paste release. IPC-7525 may have alternate design recommendations.
- 8. Board assembly site may have different recommendations for stencil design.

IMPORTANT NOTICE AND DISCLAIMER

TI PROVIDES TECHNICAL AND RELIABILITY DATA (INCLUDING DATASHEETS), DESIGN RESOURCES (INCLUDING REFERENCE DESIGNS), APPLICATION OR OTHER DESIGN ADVICE, WEB TOOLS, SAFETY INFORMATION, AND OTHER RESOURCES "AS IS" AND WITH ALL FAULTS, AND DISCLAIMS ALL WARRANTIES, EXPRESS AND IMPLIED, INCLUDING WITHOUT LIMITATION ANY IMPLIED WARRANTIES OF MERCHANTABILITY, FITNESS FOR A PARTICULAR PURPOSE OR NON-INFRINGEMENT OF THIRD PARTY INTELLECTUAL PROPERTY RIGHTS.

These resources are intended for skilled developers designing with TI products. You are solely responsible for (1) selecting the appropriate TI products for your application, (2) designing, validating and testing your application, and (3) ensuring your application meets applicable standards, and any other safety, security, regulatory or other requirements.

These resources are subject to change without notice. TI grants you permission to use these resources only for development of an application that uses the TI products described in the resource. Other reproduction and display of these resources is prohibited. No license is granted to any other TI intellectual property right or to any third party intellectual property right. TI disclaims responsibility for, and you fully indemnify TI and its representatives against any claims, damages, costs, losses, and liabilities arising out of your use of these resources.

TI's products are provided subject to [TI's Terms of Sale](#), [TI's General Quality Guidelines](#), or other applicable terms available either on ti.com or provided in conjunction with such TI products. TI's provision of these resources does not expand or otherwise alter TI's applicable warranties or warranty disclaimers for TI products. Unless TI explicitly designates a product as custom or customer-specified, TI products are standard, catalog, general purpose devices.

TI objects to and rejects any additional or different terms you may propose.

Copyright © 2026, Texas Instruments Incorporated

Last updated 10/2025