

AMC1336 小型、高精度、強化絶縁型デルタ-シグマ変調器 電圧センシング・アプリケーション用

1 特長

- 電圧測定用に最適化された入力構造
 - 入力電圧範囲: $\pm 1\text{V}$
 - 入力抵抗: $1.5\text{G}\Omega$ (標準値)
- 非常に優れた DC 性能
 - オフセット誤差: $\pm 0.5\text{mV}$ (最大値)
 - オフセット・ドリフト係数: $\pm 4\mu\text{V}/^\circ\text{C}$ (最大値)
 - ゲイン誤差: $\pm 0.25\%$ (最大値)
 - ゲイン・ドリフト係数: $\pm 40\text{ppm}/^\circ\text{C}$ (最大値)
- 過渡耐性: $115\text{ kV}/\mu\text{s}$ (標準値)
- ハイサイド電源喪失の検出
- 安全関連の認定
 - DIN VDE V 0884-11: 2017-01 に準拠した強化絶縁耐圧: $8000\text{V}_{\text{PEAK}}$
 - UL 1577 に準拠した絶縁耐圧: $5700\text{V}_{\text{RMS}}$ (1 分間)
 - IEC 62368-1 最終機器標準

2 アプリケーション

- 次の用途での絶縁 AC および DC 電圧測定
 - 無停電電源
 - 太陽光発電インバータ
 - モータ・ドライブ

3 概要

AMC1336 は高精度のデルタ-シグマ ($\Delta\Sigma$) 変調器で、磁気干渉に対して高い耐性のある二重の静電容量性絶縁バリアを採用して、入力回路と出力回路を電気的に分離しています。この絶縁バリアは、DIN VDE V 0884-11 および UL1577 規格に準拠した、 $8000\text{V}_{\text{PEAK}}$ までの強化絶縁体に認定されています。この絶縁変調器を絶縁電源と組み合わせて使用すると、システムの中で異なる同相電圧レベルで動作する部分が分離され、低電圧部分の損傷を防ぎます。

AMC1336 独自の広いバイポーラの $\pm 1\text{V}$ 入力電圧範囲と、高い入力抵抗から、高電圧アプリケーションでデバイスを分圧抵抗に直接接続できます。デジタル・フィルタ (TMS320F28004x、TMS320F2807x、TMS320F2837x マイクロコントローラ・ファミリに内蔵されているものなど) を使用して出力ビットストリームを間引くと、 82kSPS のデータ速度、 87dB のダイナミック・レンジで、16 ビットの分解能が得られます。

ハイサイドでは、AMC1336 は 3.3V または 5V 電源から給電されます。絶縁デジタル・インターフェイスは、 3.0V 、 3.3V 、 5V の電源で動作します。

AMC1336 は、 $-40^\circ\text{C} \sim +125^\circ\text{C}$ の拡張工業用温度範囲で動作が規定されています。

製品情報⁽¹⁾

型番	パッケージ	本体サイズ(公称)
AMC1336	SOIC (8)	5.85mm×7.50mm

(1) 利用可能なすべてのパッケージについては、このデータシートの末尾にある注文情報を参照してください。

概略回路図

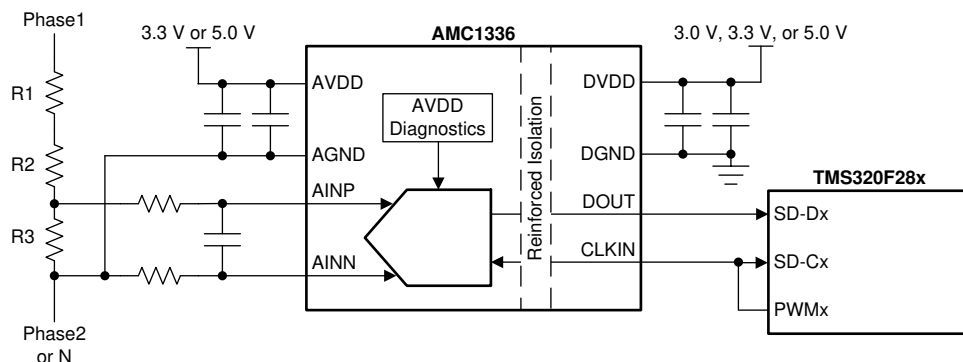

目次

1	特長	1	7.2	Functional Block Diagram	17
2	アプリケーション	1	7.3	Feature Description	17
3	概要	1	7.4	Device Functional Modes	23
4	改訂履歴	2	8	Application and Implementation	24
5	Pin Configuration and Functions	3	8.1	Application Information	24
6	Specifications	4	8.2	Typical Application	25
6.1	Absolute Maximum Ratings	4	9	Power Supply Recommendations	29
6.2	ESD Ratings	4	10	Layout	30
6.3	Recommended Operating Conditions	4	10.1	Layout Guidelines	30
6.4	Thermal Information	5	10.2	Layout Example	30
6.5	Power Ratings	5	11	デバイスおよびドキュメントのサポート	31
6.6	Insulation Specifications	6	11.1	デバイス・サポート	31
6.7	Safety-Related Certifications	7	11.2	ドキュメントのサポート	31
6.8	Safety Limiting Values	7	11.3	ドキュメントの更新通知を受け取る方法	31
6.9	Electrical Characteristics	7	11.4	コミュニティ・リソース	31
6.10	Switching Characteristics	9	11.5	商標	31
6.11	Insulation Characteristics Curves	10	11.6	静電気放電に関する注意事項	31
6.12	Typical Characteristics	11	11.7	Glossary	31
7	Detailed Description	17	12	メカニカル、パッケージ、および注文情報	32
7.1	Overview	17			

4 改訂履歴

資料番号末尾の英字は改訂を表しています。その改訂履歴は英語版に準じています。

Revision A (December 2019) から Revision B に変更	Page
• Changed P_D ($AVDD = DVDD = 5.5\text{ V}$) from 88 mW to 90.75 mW	5
• Changed P_{D1} ($AVDD = 5.5\text{ V}$) from 55 mW to 57.75 mW	5
• Added UL certification file number	7

2019年8月発行のものから更新	Page
• ドキュメント・ステータスを事前情報から量産データに変更	1

5 Pin Configuration and Functions

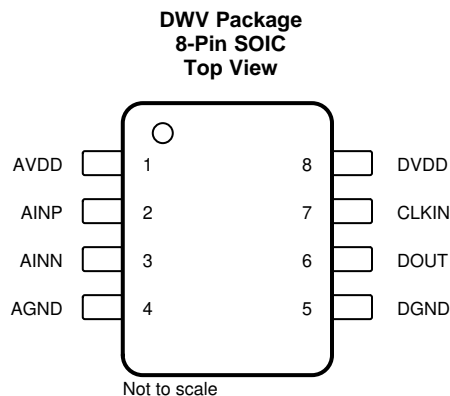

Pin Functions

PIN		I/O	DESCRIPTION
NO.	NAME		
1	AVDD	—	Analog (high-side) power supply, 3.0 V to 5.5 V. See the Power Supply Recommendations section for decoupling recommendations.
2	AINP	I	Noninverting analog input
3	AINN	I	Inverting analog input
4	AGND	—	Analog (high-side) ground reference
5	DGND	—	Digital (controller-side) ground reference
6	DOUT	O	Modulator bitstream output, updated with the rising edge of the clock signal present on CLKIN. Use the rising edge of the clock to latch the modulator bitstream at the input of the digital filter device.
7	CLKIN	I	Modulator clock input with internal pulldown resistor (typical value: 1 M Ω). The clock signal must be applied continuously for proper device operation; see the Clock Input section for additional details.
8	DVDD	—	Digital (controller-side) power supply, 2.7 V to 5.5 V. See the Power Supply Recommendations section for decoupling recommendations.

6 Specifications

6.1 Absolute Maximum Ratings

see⁽¹⁾

		MIN	MAX	UNIT
Power-supply voltage	AVDD to AGND	-0.3	6.5	V
	DVDD to DGND	-0.3	6.5	
Analog input voltage	On the AINP and AINN pins	AGND – 5	AVDD + 0.5	V
Digital input voltage	On the CLKIN pin	DGND – 0.5	DVDD + 0.5	V
Digital output voltage	On the DOUT pin	DGND – 0.5	DVDD + 0.5	V
Input current	Continuous, any pin except power-supply pins	-10	10	mA
Temperature	Junction, T _J		150	°C
	Storage, T _{stg}	-65	150	

(1) Stresses beyond those listed under *Absolute Maximum Ratings* may cause permanent damage to the device. These are stress ratings only, which do not imply functional operation of the device at these or any other conditions beyond those indicated under *Recommended Operating Conditions*. Exposure to absolute-maximum-rated conditions for extended periods may affect device reliability.

6.2 ESD Ratings

			VALUE	UNIT
V _(ESD)	Electrostatic discharge	Human-body model (HBM), per ANSI/ESDA/JEDEC JS-001 ⁽¹⁾	±2000	V
		Charged-device model (CDM), per JEDEC specification JESD22-C101 ⁽²⁾	±1000	

(1) JEDEC document JEP155 states that 500-V HBM allows safe manufacturing with a standard ESD control process.

(2) JEDEC document JEP157 states that 250-V CDM allows safe manufacturing with a standard ESD control process.

6.3 Recommended Operating Conditions

over operating ambient temperature range (unless otherwise noted)

				MIN	NOM	MAX	UNIT
POWER SUPPLY							
AVDD	High-side supply voltage	AVDD to AGND		3.0	5.0	5.5	V
DVDD	Controller-side	DVDD to DGND		2.7	3.3	5.5	V
ANALOG INPUT							
V _{Clipping}	Differential input voltage before clipping output	V _{IN} = V _{AINP} – V _{AINN}		±1.25			V
V _{FSR}	Specified linear differential full-scale voltage	V _{IN} = V _{AINP} – V _{AINN}		-1		1	V
	Absolute common-mode input voltage ⁽¹⁾	(V _{AINP} + V _{AINN}) / 2 to AGND		-2		AVDD	V
V _{CM}	Operating common-mode input voltage ⁽²⁾	(V _{AINP} + V _{AINN}) / 2 to AGND, 3.0 V ≤ AVDD < 4 V, V _{AINP} = V _{AINN}		-1.4		AVDD – 1.4	V
		(V _{AINP} + V _{AINN}) / 2 to AGND, 3.0 V ≤ AVDD < 4.5 V, V _{AINP} – V _{AINN} = 1.25 V		-0.8		AVDD – 2.4	
		(V _{AINP} + V _{AINN}) / 2 to AGND, 4 V ≤ AVDD ≤ 5.5 V, V _{AINP} = V _{AINN}		-1.4		2.7	
		(V _{AINP} + V _{AINN}) / 2 to AGND, 4.5 V ≤ AVDD ≤ 5.5 V, V _{AINP} – V _{AINN} = 1.25 V		-0.8		2.1	
DIGITAL INPUT							
	Input voltage	V _{CLKIN} to DGND		DGND		DVDD	V
TEMPERATURE RANGE							
T _A	Operating ambient temperature			-40	25	125	°C

(1) Steady-state voltage supported by the device in case of a system failure. See specified common-mode input voltage V_{CM} for normal operation. Observe analog input voltage range as specified in the *Absolute Maximum Ratings* table.

(2) See the *Analog Input* section for more details.

6.4 Thermal Information

THERMAL METRIC ⁽¹⁾		AMC1336	
		DWV (SOIC)	
		8 PINS	
			UNIT
R _{θJA}	Junction-to-ambient thermal resistance	94	°C/W
R _{θJC(top)}	Junction-to-case (top) thermal resistance	36	°C/W
R _{θJB}	Junction-to-board thermal resistance	46.1	°C/W
ψ _{JT}	Junction-to-top characterization parameter	11.5	°C/W
ψ _{JB}	Junction-to-board characterization parameter	44.4	°C/W
R _{θJC(bot)}	Junction-to-case (bottom) thermal resistance	N/A	°C/W

- (1) For more information about traditional and new thermal metrics, see the [Semiconductor and IC Package Thermal Metrics application report](#).

6.5 Power Ratings

PARAMETER		TEST CONDITIONS	VALUE	UNIT
P _D	Maximum power dissipation (both sides)	AVDD = DVDD = 5.5 V	90.75	mW
		AVDD = DVDD = 3.6 V	50.4	
P _{D1}	Maximum power dissipation (high-side supply)	AVDD = 5.5 V	57.75	mW
		AVDD = 3.6 V	32.4	
P _{D2}	Maximum power dissipation (controller-side supply)	DVDD = 5.5 V	33	mW
		DVDD = 3.6 V	18	

6.6 Insulation Specifications

over operating ambient temperature range (unless otherwise noted)

PARAMETER		TEST CONDITIONS	VALUE	UNIT
GENERAL				
CLR	External clearance ⁽¹⁾	Shortest pin-to-pin distance through air	≥ 8.5	mm
CPG	External creepage ⁽¹⁾	Shortest pin-to-pin distance across the package surface	≥ 8.5	mm
DTI	Distance through insulation	Minimum internal gap (internal clearance) of the double insulation	≥ 0.021	mm
CTI	Comparative tracking index	DIN EN 60112 (VDE 0303-11); IEC 60112	≥ 600	V
	Material group	According to IEC 60664-1	I	
	Overvoltage category per IEC 60664-1	Rated mains voltage ≤ 600 V _{RMS}	I-IV	
		Rated mains voltage ≤ 1000 V _{RMS}	I-III	
DIN VDE V 0884-11: 2017-01⁽²⁾				
V _{IORM}	Maximum repetitive peak isolation voltage	At AC voltage	2121	V _{PK}
V _{IOWM}	Maximum-rated isolation working voltage	At AC voltage (sine wave); see 5	1500	V _{RMS}
		At DC voltage	2121	V _{DC}
V _{IOTM}	Maximum transient isolation voltage	V _{TEST} = V _{IOTM} , t = 60 s (qualification test)	8000	V _{PK}
		V _{TEST} = 1.2 × V _{IOTM} , t = 1 s (100% production test)	9600	
V _{IOSM}	Maximum surge isolation voltage ⁽³⁾	Test method per IEC 60065, 1.2/50-μs waveform, V _{TEST} = 1.6 × V _{IOSM} = 12800 V _{PK} (qualification)	8000	V _{PK}
q _{pd}	Apparent charge ⁽⁴⁾	Method a, after input/output safety test subgroups 2 & 3, V _{ini} = V _{IOTM} , t _{ini} = 60 s, V _{pd(m)} = 1.2 × V _{IORM} , t _m = 10 s	≤ 5	pC
		Method a, after environmental tests subgroup 1, V _{ini} = V _{IOTM} , t _{ini} = 60 s, V _{pd(m)} = 1.6 × V _{IORM} , t _m = 10 s	≤ 5	
		Method b1, at routine test (100% production) and preconditioning (type test), V _{ini} = V _{IOTM} , t _{ini} = 1 s, V _{pd(m)} = 1.875 × V _{IORM} , t _m = 1 s	≤ 5	
C _{IO}	Barrier capacitance, input to output ⁽⁵⁾	V _{IO} = 0.5 V _{PP} at 1 MHz	~1	pF
R _{IO}	Insulation resistance, input to output ⁽⁵⁾	V _{IO} = 500 V at T _A = 25°C	> 10 ¹²	Ω
		V _{IO} = 500 V at 100°C ≤ T _A ≤ 125°C	> 10 ¹¹	
		V _{IO} = 500 V at T _S = 150°C	> 10 ⁹	
	Pollution degree		2	
	Climatic category		55/125/21	
UL1577				
V _{ISO}	Withstand isolation voltage	V _{TEST} = V _{ISO} = 5700 V _{RMS} , t = 60 s (qualification), V _{TEST} = 1.2 × V _{ISO} = 6840 V _{RMS} , t = 1 s (100% production test)	5700	V _{RMS}

- (1) Apply creepage and clearance requirements according to the specific equipment isolation standards of an application. Care must be taken to maintain the creepage and clearance distance of a board design to ensure that the mounting pads of the isolator on the printed circuit board (PCB) do not reduce this distance. Creepage and clearance on a PCB become equal in certain cases. Techniques such as inserting grooves, ribs, or both on a PCB are used to help increase these specifications.
- (2) This coupler is suitable for *safe electrical insulation* only within the safety ratings. Compliance with the safety ratings shall be ensured by means of suitable protective circuits.
- (3) Testing is carried out in air or oil to determine the intrinsic surge immunity of the isolation barrier.
- (4) Apparent charge is electrical discharge caused by a partial discharge (pd).
- (5) All pins on each side of the barrier are tied together, creating a two-pin device.

6.7 Safety-Related Certifications

VDE	UL
Certified according to DIN VDE V 0884-11: 2017-01, DIN EN 62368-1: 2016-05, EN 62368-1: 2014, and IEC 62368-1: 2014	Recognized under 1577 component recognition
Reinforced insulation	Single protection
Certificate number: 40040142	File number: E181974

6.8 Safety Limiting Values

Safety limiting intends to minimize potential damage to the isolation barrier upon failure of input or output circuitry.

PARAMETER		TEST CONDITIONS	MIN	TYP	MAX	UNIT
I _S	Safety input, output, or supply current	R _{θJA} = 94°C/W, T _J = 150°C, T _A = 25°C, AVDD = DVDD = 5.5 V, see Figure 3			241	mA
		R _{θJA} = 94°C/W, T _J = 150°C, T _A = 25°C, AVDD = DVDD = 3.6 V, see Figure 3			369	
P _S	Safety input, output, or total power ⁽¹⁾	R _{θJA} = 94°C/W, T _J = 150°C, T _A = 25°C, see Figure 4			1329	mW
T _S	Maximum safety temperature				150	°C

- (1) The maximum safety temperature, T_S, has the same value as the maximum junction temperature, T_J, specified for the device. The I_S and P_S parameters represent the safety current and safety power, respectively. Do not exceed the maximum limits of I_S and P_S. These limits vary with the ambient temperature, T_A.

The junction-to-air thermal resistance, R_{θJA}, in the [Thermal Information](#) table is that of a device installed on a high-K test board for leaded surface-mount packages. Use these equations to calculate the value for each parameter:

T_J = T_A + R_{θJA} × P, where P is the power dissipated in the device.

T_{J(max)} = T_S = T_A + R_{θJA} × P_S, where T_{J(max)} is the maximum junction temperature.

P_S = I_S × AVDD_{max} + I_S × DVDD_{max}, where AVDD_{max} is the maximum high-side voltage and DVDD_{max} is the maximum controller-side supply voltage.

6.9 Electrical Characteristics

minimum and maximum specifications apply from T_A = –40°C to +125°C, AVDD = 3.0 V to 5.5 V, DVDD = 2.7 V to 5.5 V, AINP = –1 V to +1 V, and AINN = AGND = 0 V; typical specifications are at T_A = 25°C, AVDD = 5 V, DVDD = 3.3 V, and f_{CLKIN} = 20 MHz (unless otherwise noted)

PARAMETER		TEST CONDITIONS	MIN	TYP	MAX	UNIT
ANALOG INPUT						
R _{IN}	Single-ended input resistance	AINN = AGND	0.1	1.5		GΩ
R _{IND}	Differential input resistance		0.16	1.5		GΩ
C _{IN}	Single-ended input capacitance	AINN = AGND, f _{CLKIN} = 20 MHz		2		pF
C _{IND}	Differential input capacitance	f _{CLKIN} = 20 MHz		2		pF
I _{IB}	Input bias current	AINP = AINN = AGND; I _{IB} = (I _{AINP} + I _{AINN}) / 2	–10	±3	10	nA
TCI _{IB}	Input bias current drift	AINP = AINN = AGND; I _{IB} = (I _{AINP} + I _{AINN}) / 2		–14		pA/°C
I _{IO}	Input offset current	I _{IO} = I _{AINP} – I _{AINN}	–5	±1	5	nA
CMTI	Common-mode transient immunity	AGND – DGND = 1 kV	80	115		kV/μs

Electrical Characteristics (continued)

minimum and maximum specifications apply from $T_A = -40^{\circ}\text{C}$ to $+125^{\circ}\text{C}$, $AVDD = 3.0\text{ V}$ to 5.5 V , $DVDD = 2.7\text{ V}$ to 5.5 V , $AINP = -1\text{ V}$ to $+1\text{ V}$, and $AINN = AGND = 0\text{ V}$; typical specifications are at $T_A = 25^{\circ}\text{C}$, $AVDD = 5\text{ V}$, $DVDD = 3.3\text{ V}$, and $f_{CLKIN} = 20\text{ MHz}$ (unless otherwise noted)

PARAMETER		TEST CONDITIONS	MIN	TYP	MAX	UNIT
DC ACCURACY						
	Resolution	Decimation filter output set to 16 bits	16			Bit
INL	Integral nonlinearity ⁽¹⁾	Resolution: 16 bits	-4	± 1.6	4	LSB
E_O	Offset error	Initial, at $T_A = 25^{\circ}\text{C}$, $AINP = AINN = AGND$	-0.5	± 0.03	0.5	mV
TCE_O	Offset error drift ⁽²⁾		-4	± 0.6	4	$\mu\text{V}/^{\circ}\text{C}$
E_G	Gain error ⁽³⁾	Initial, at $T_A = 25^{\circ}\text{C}$, $V_{AINP} = 1\text{ V}$ or $V_{AINN} = -1\text{ V}$, $AINN = AGND$	-0.25	± 0.02	0.25	%
TCE_G	Gain error drift ⁽⁴⁾		-40	± 20	40	ppm/ $^{\circ}\text{C}$
CMRR	Common-mode rejection ratio	$AINP = AINN$, $f_{IN} = 0\text{ Hz}$, $V_{CM\ min} \leq V_{CM} \leq V_{CM\ max}$		-104		dB
		$AINP = AINN$, $f_{IN} = 10\text{ kHz}$, $-0.5\text{ V} \leq V_{IN} \leq 0.5\text{ V}$		-96		
PSRR	Power-supply rejection ratio	PSRR vs AVDD, at DC		-83		dB
		PSRR vs AVDD, 100-mV and 10-kHz ripple		-83		
AC ACCURACY						
SNR	Signal-to-noise ratio	$V_{IN} = 2 V_{PP}$, $f_{IN} = 1\text{ kHz}$	82	87		dB
SINAD	Signal-to-noise + distortion	$V_{IN} = 2 V_{PP}$, $f_{IN} = 1\text{ kHz}$	79	85		dB
THD	Total harmonic distortion	$V_{IN} = 2 V_{PP}$, $f_{IN} = 1\text{ kHz}$		-91	-80	dB
SFDR	Spurious-free dynamic range	$V_{IN} = 2 V_{PP}$, $f_{IN} = 1\text{ kHz}$	80	92		dB
DIGITAL INPUT (CMOS Logic With Schmitt-Trigger)						
I_{IN}	Input current	$DGND \leq V_{IN} \leq DVDD$			7	μA
C_{IN}	Input capacitance			4		pF
V_{IH}	High-level input voltage		$0.7 \times DVDD$		$DVDD + 0.3$	V
V_{IL}	Low-level input voltage		-0.3		$0.3 \times DVDD$	V
DIGITAL OUTPUT (CMOS)						
C_{LOAD}	Output load capacitance	$f_{CLKIN} = 21\text{ MHz}$		15	30	pF
V_{OH}	High-level output voltage	$I_{OH} = -20\ \mu\text{A}$		$DVDD - 0.1$		V
		$I_{OH} = -4\text{ mA}$		$DVDD - 0.4$		
V_{OL}	Low-level output voltage	$I_{OL} = 20\ \mu\text{A}$			0.1	V
		$I_{OL} = 4\text{ mA}$			0.4	
POWER SUPPLY						
$AVDD_{POR}$	AVDD power-on reset threshold voltage	AVDD falling	2.4	2.6	2.8	V
I_{AVDD}	High-side supply current	$3\text{ V} \leq AVDD \leq 3.6\text{ V}$		6.8	9	mA
		$4.5\text{ V} \leq AVDD \leq 5.5\text{ V}$		7.8	10.5	
I_{DVDD}	Controller-side supply current	$2.7\text{ V} \leq DVDD \leq 3.6\text{ V}$, $C_{LOAD} = 15\text{ pF}$		3.4	5	mA
		$4.5\text{ V} \leq DVDD \leq 5.5\text{ V}$, $C_{LOAD} = 15\text{ pF}$		3.7	6	

- (1) Integral nonlinearity is defined as the maximum deviation from a straight line passing through the end-points of the ideal ADC transfer function expressed as number of LSBs or as a percent of the specified linear full-scale range FSR.
- (2) Offset error drift is calculated using the box method, as described by the following equation:

$$TCE_O = (\text{value}_{MAX} - \text{value}_{MIN}) / \text{TempRange}$$
- (3) The typical value includes one sigma statistical variation.
- (4) Gain error drift is calculated using the box method, as described by the following equation:

$$TCE_G (\text{ppm}) = ((\text{value}_{MAX} - \text{value}_{MIN}) / (\text{value} \times \text{TempRange})) \times 10^6$$

6.10 Switching Characteristics

over operating ambient temperature range (unless otherwise noted)

PARAMETER		TEST CONDITIONS	MIN	TYP	MAX	UNIT
f_{CLKIN}	CLKIN clock frequency	$3.0\text{ V} \leq \text{AVDD} \leq 5.5\text{ V}$	9	20	21	MHz
		$4.5\text{ V} \leq \text{AVDD} \leq 5.5\text{ V}$	5	20	21	
	CLKIN duty cycle		40%	50%	60%	
t_{H1}	DOUT hold time after rising edge of CLKIN	$C_{\text{LOAD}} = 15\text{ pF}$	3.5			ns
t_{D1}	Rising edge of CLKIN to DOUT valid delay	$C_{\text{LOAD}} = 15\text{ pF}$			15	ns
t_r	DOUT rise time	10% to 90%, $2.7\text{ V} \leq \text{DVDD} \leq 3.6\text{ V}$, $C_{\text{LOAD}} = 15\text{ pF}$		2.5	6	ns
		10% to 90%, $4.5\text{ V} \leq \text{DVDD} \leq 5.5\text{ V}$, $C_{\text{LOAD}} = 15\text{ pF}$		3.2	6	ns
t_f	DOUT fall time	10% to 90%, $2.7\text{ V} \leq \text{DVDD} \leq 3.6\text{ V}$, $C_{\text{LOAD}} = 15\text{ pF}$		2.2	6	ns
		10% to 90%, $4.5\text{ V} \leq \text{DVDD} \leq 5.5\text{ V}$, $C_{\text{LOAD}} = 15\text{ pF}$		2.9	6	ns
t_{ASTART}	Analog start-up time	AVDD step to 3.0 V; 0.1%-settling, clock applied		0.25		ms

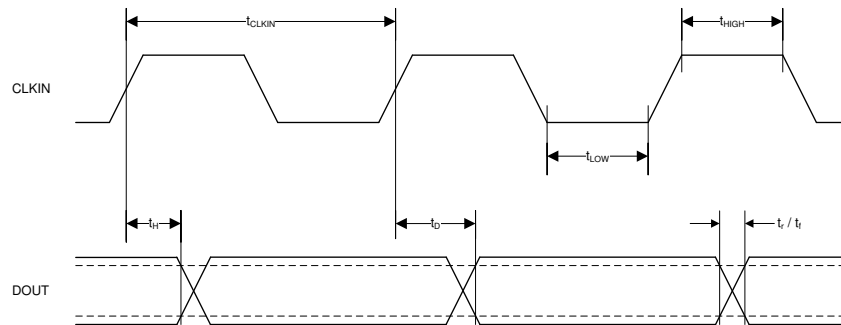

1. Digital Interface Timing

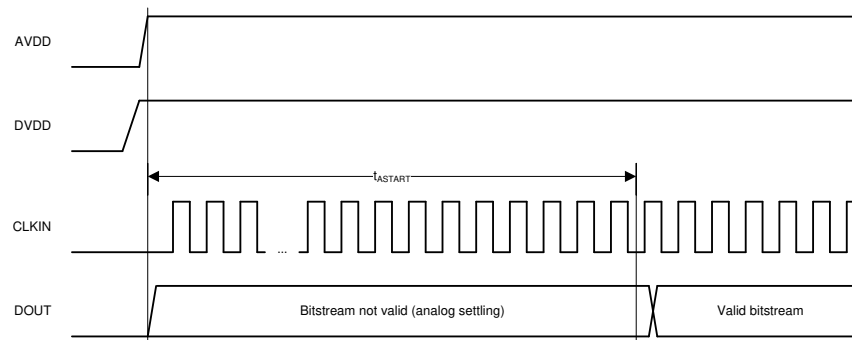

2. Device Start-Up Timing

6.11 Insulation Characteristics Curves

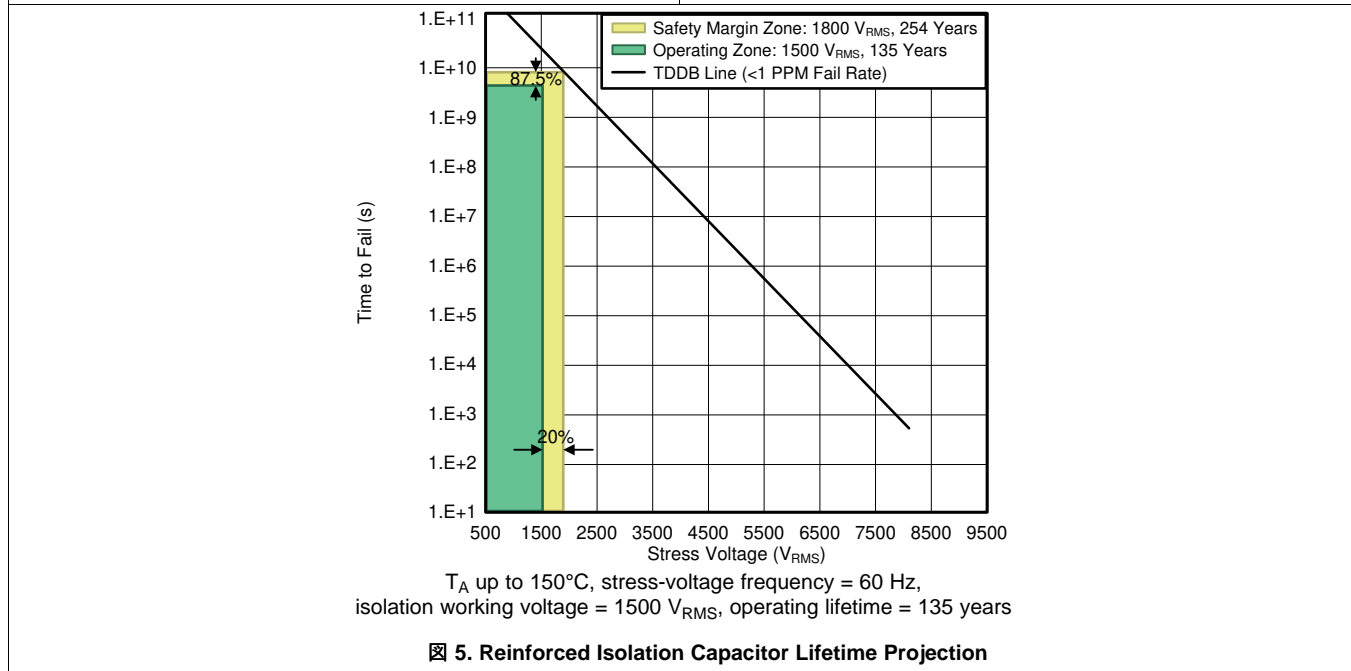
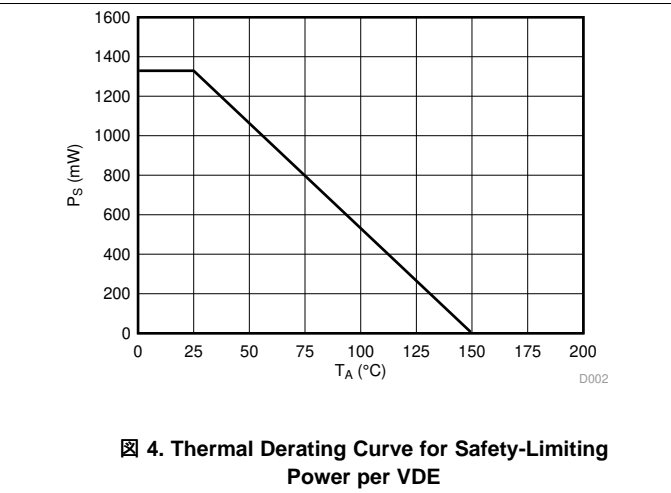
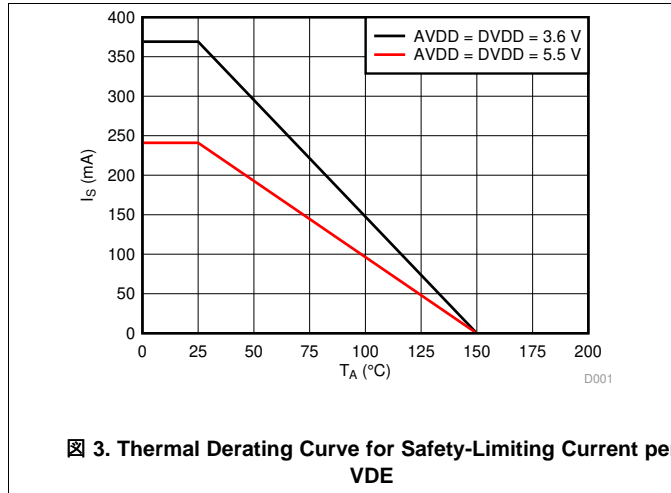

6.12 Typical Characteristics

at AVDD = 5 V, DVDD = 3.3 V, AINP = -1 V to 1 V, AINN = AGND, $f_{CLKIN} = 20$ MHz, and sinc³ filter with OSR = 256 (unless otherwise noted)



图 6. Input Bias Current vs Common-Mode Input Voltage



图 7. Integral Nonlinearity vs Input Voltage

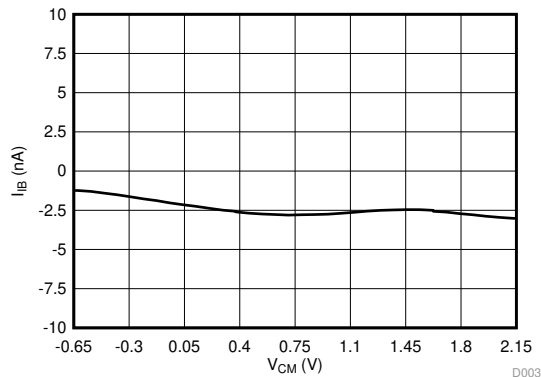

图 8. Integral Nonlinearity vs Temperature

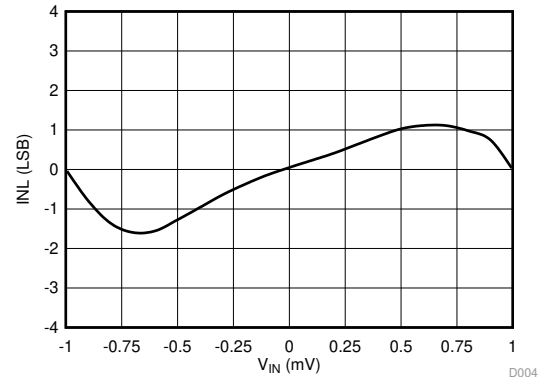

图 9. Offset Error Histogram

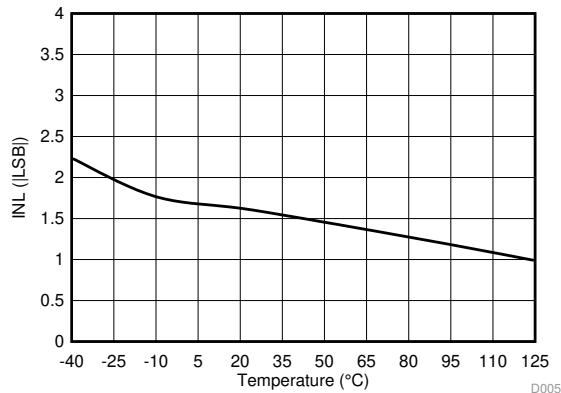

图 10. Offset Error vs High-Side Supply Voltage

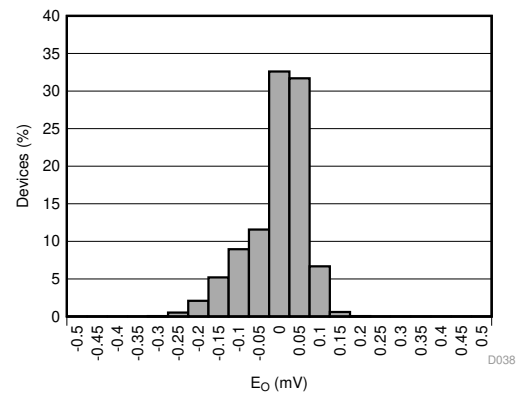

图 11. Offset Error vs Temperature

Typical Characteristics (continued)

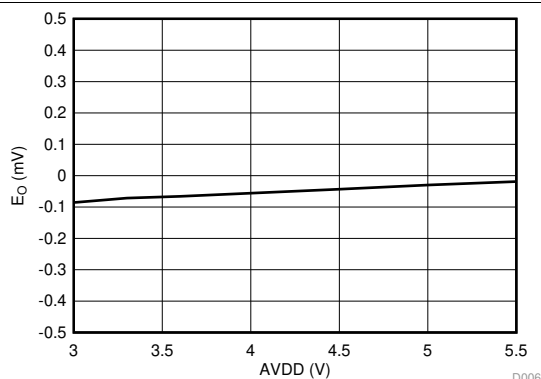
at AVDD = 5 V, DVDD = 3.3 V, AINP = -1 V to 1 V, AINN = AGND, $f_{CLKIN} = 20$ MHz, and sinc³ filter with OSR = 256 (unless otherwise noted)

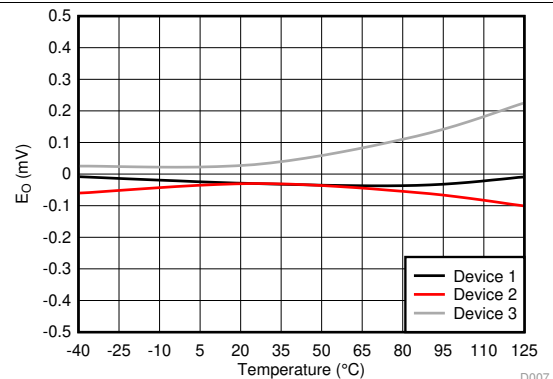
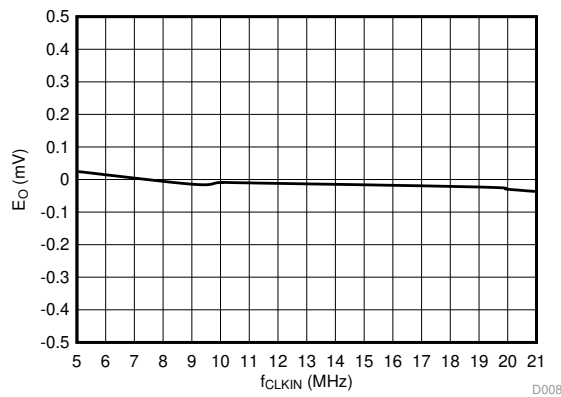

$f_{CLKIN} < 9$ MHz with AVDD \geq 4.5 V only

Figure 12. Offset Error vs Clock Frequency

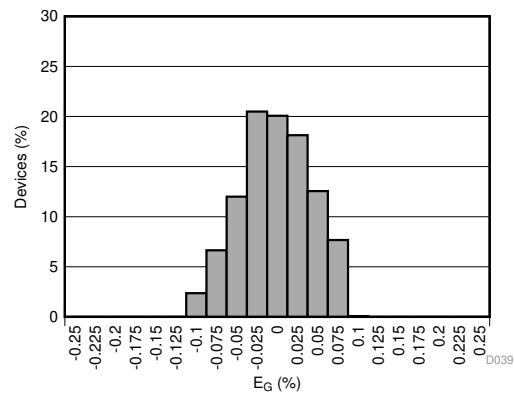

Figure 13. Gain Error Histogram

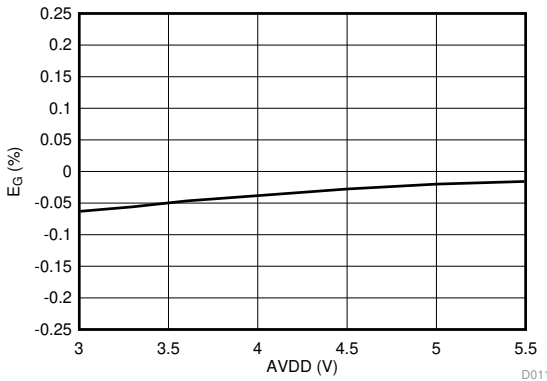

Figure 14. Gain Error vs High-Side Supply Voltage

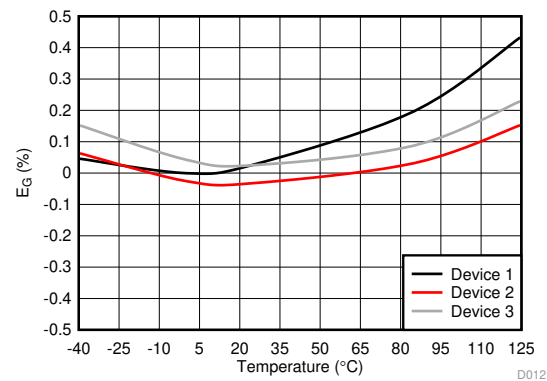
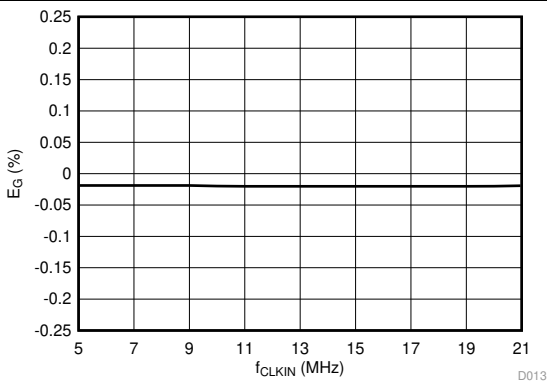

Figure 15. Gain Error vs Temperature



$f_{CLKIN} < 9$ MHz with AVDD \geq 4.5 V only

Figure 16. Gain Error vs Clock Frequency

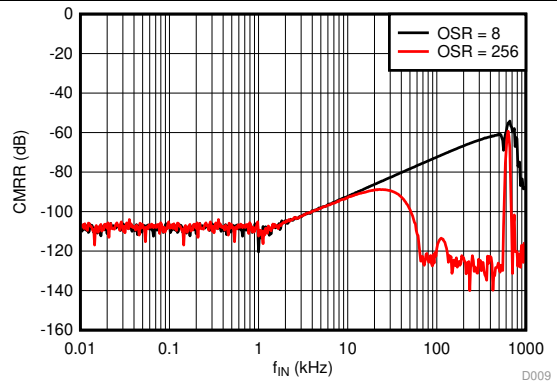
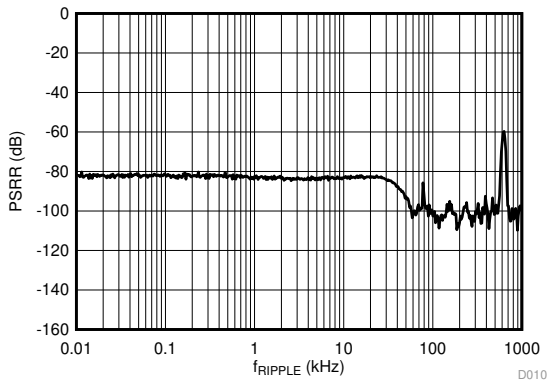

Figure 17. Common-Mode Rejection Ratio vs Input Signal Frequency

Typical Characteristics (continued)

at AVDD = 5 V, DVDD = 3.3 V, AINP = -1 V to 1 V, AINN = AGND, $f_{CLKIN} = 20$ MHz, and sinc³ filter with OSR = 256 (unless otherwise noted)



18. Power-Supply Rejection Ratio vs Ripple Frequency

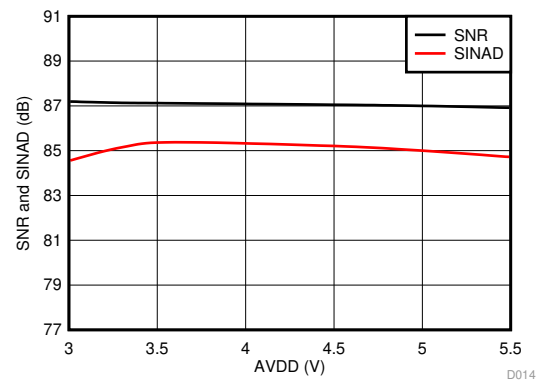

19. Signal-to-Noise Ratio and Signal-to-Noise + Distortion vs High-Side Supply Voltage

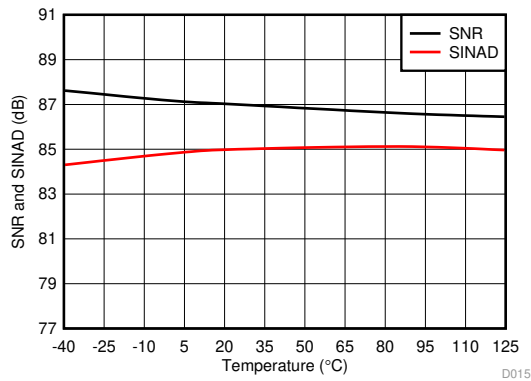

20. Signal-to-Noise Ratio and Signal-to-Noise + Distortion vs Temperature

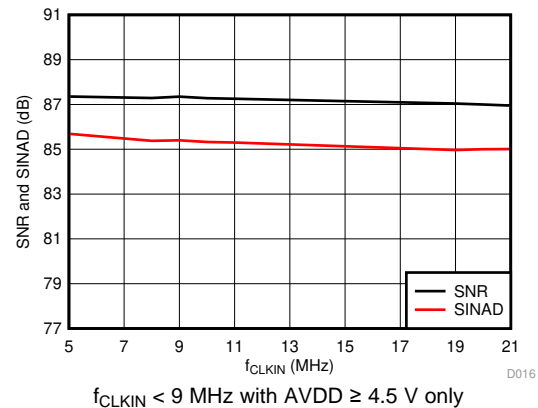

21. Signal-to-Noise Ratio and Signal-to-Noise + Distortion vs Clock Frequency

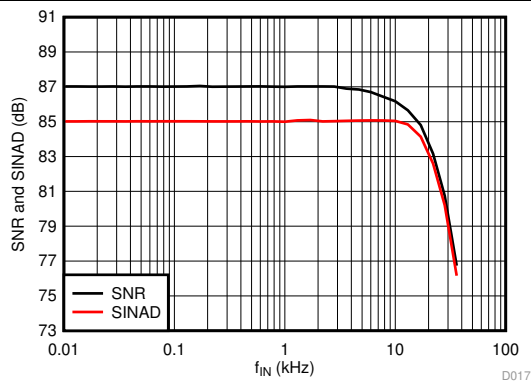

22. Signal-to-Noise Ratio and Signal-to-Noise + Distortion vs Input Signal Frequency

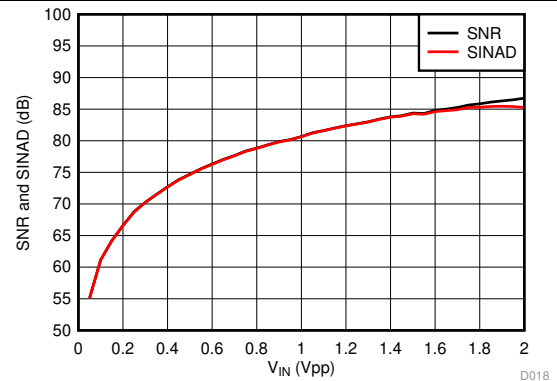

23. Signal-to-Noise Ratio and Signal-to-Noise + Distortion vs Input Signal Amplitude

Typical Characteristics (continued)

at AVDD = 5 V, DVDD = 3.3 V, AINP = -1 V to 1 V, AINN = AGND, $f_{CLKIN} = 20$ MHz, and sinc³ filter with OSR = 256 (unless otherwise noted)

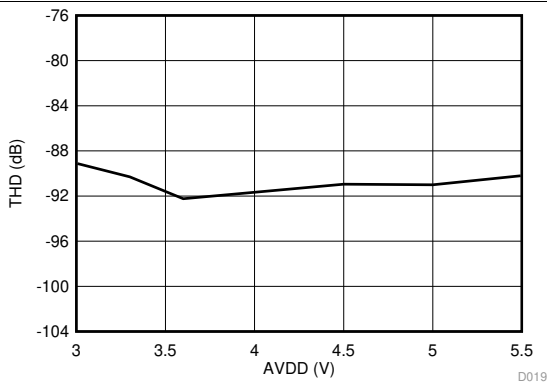

Figure 24. Total Harmonic Distortion vs High-Side Supply Voltage

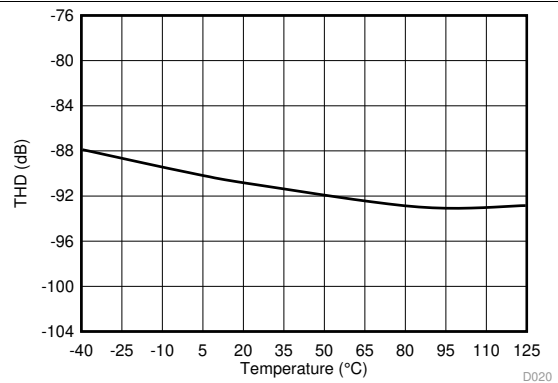

Figure 25. Total Harmonic Distortion vs Temperature

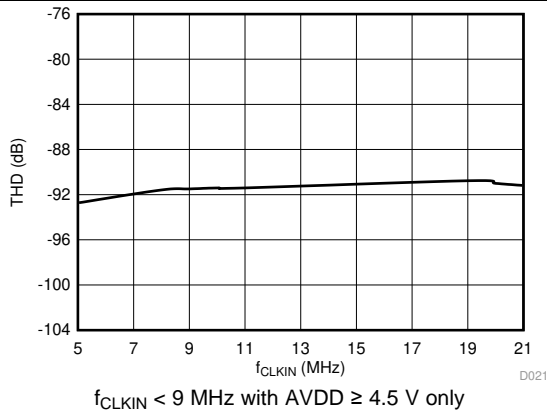

Figure 26. Total Harmonic Distortion vs Clock Frequency

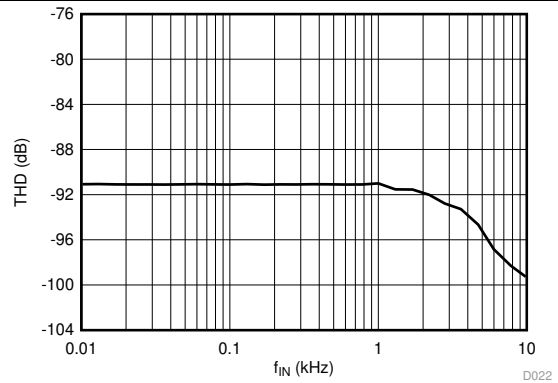

Figure 27. Total Harmonic Distortion vs Input Signal Frequency

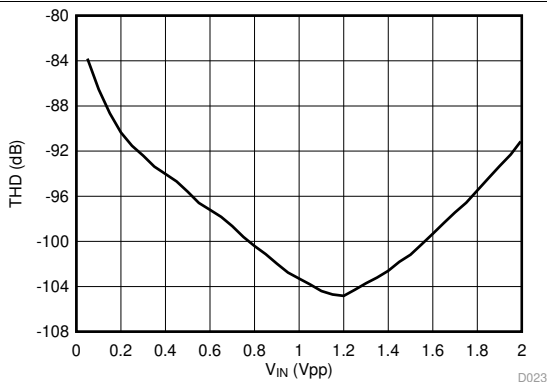

Figure 28. Total Harmonic Distortion vs Input Signal Amplitude

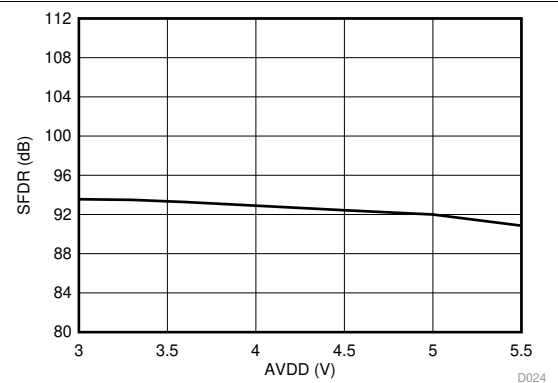
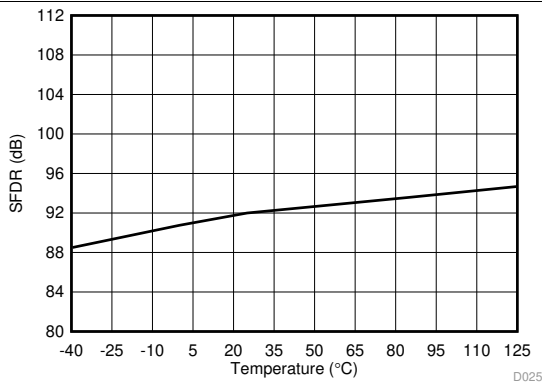

Figure 29. Spurious-Free Dynamic Range vs High-Side Supply Voltage

Typical Characteristics (continued)

at AVDD = 5 V, DVDD = 3.3 V, AINP = -1 V to 1 V, AINN = AGND, $f_{CLKIN} = 20$ MHz, and sinc³ filter with OSR = 256 (unless otherwise noted)



30. Spurious-Free Dynamic Range vs Temperature

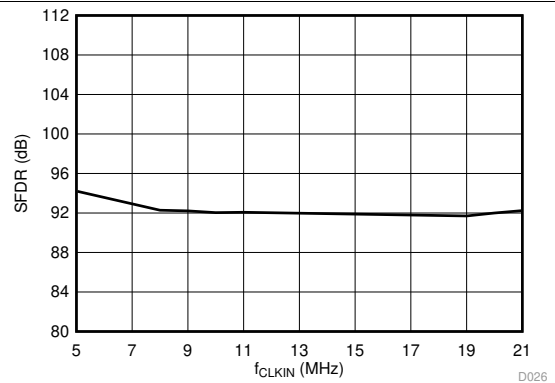

$f_{CLKIN} < 9$ MHz with AVDD ≥ 4.5 V only

31. Spurious-Free Dynamic Range vs Clock Frequency

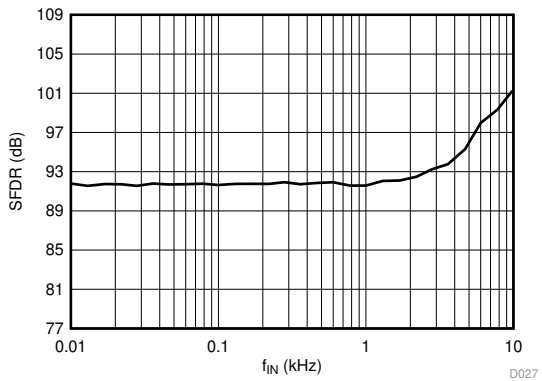

32. Spurious-Free Dynamic Range vs Input Signal Frequency

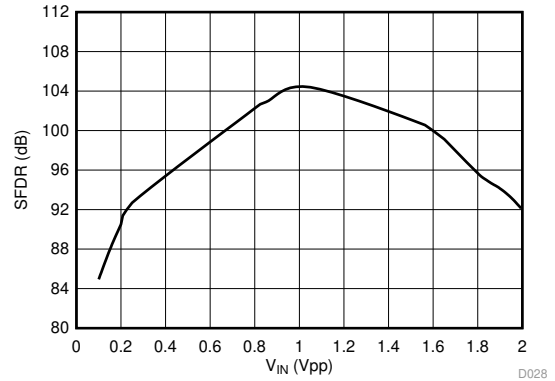

33. Spurious-Free Dynamic Range vs Input Signal Amplitude

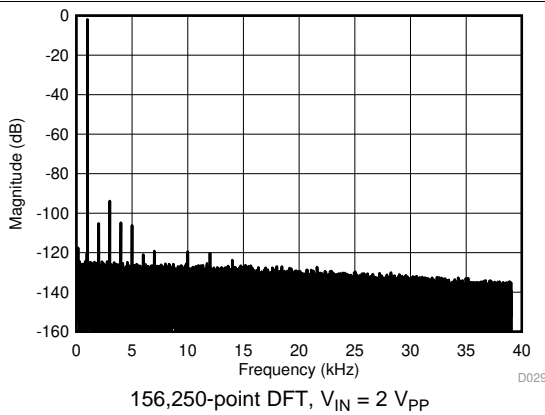

34. Frequency Spectrum with 1-kHz Input Signal

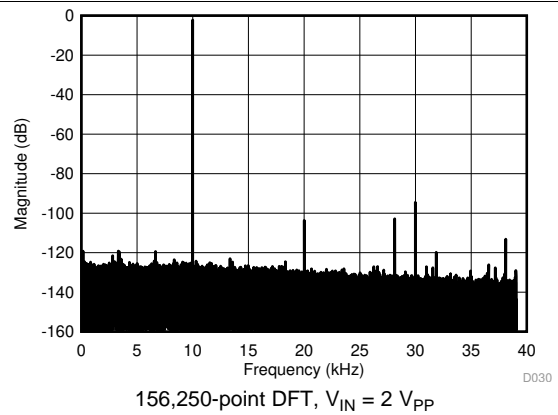

35. Frequency Spectrum with 10-kHz Input Signal

Typical Characteristics (continued)

at AVDD = 5 V, DVDD = 3.3 V, AINP = -1 V to 1 V, AINN = AGND, f_{CLKIN} = 20 MHz, and sinc³ filter with OSR = 256 (unless otherwise noted)

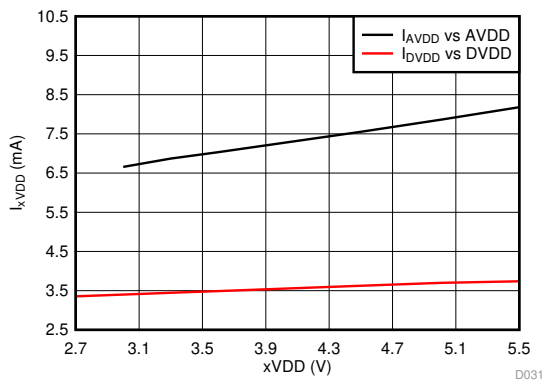

36. Supply Current vs Supply Voltage

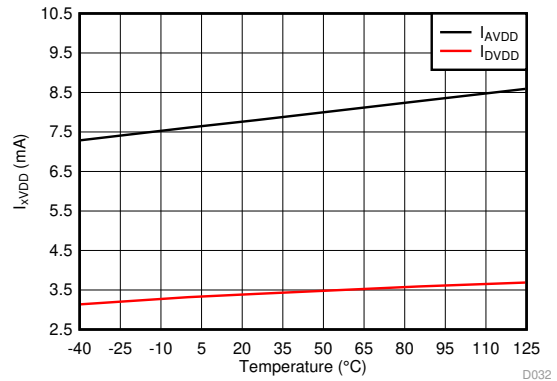

37. Supply Current vs Temperature

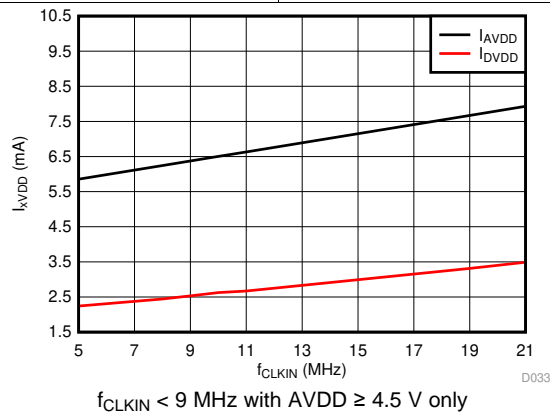

f_{CLKIN} < 9 MHz with AVDD ≥ 4.5 V only

38. Supply Current vs Clock Frequency

7 Detailed Description

7.1 Overview

The differential analog input (comprised of input signals AINP and AINN) of the AMC1336 is a chopper-stabilized instrumentation amplifier, followed by the switched-capacitor input of a second-order, delta-sigma ($\Delta\Sigma$) modulator stage that digitizes the input signal into a 1-bit output stream. The data output DOUT of the converter provides a stream of digital ones and zeros that is synchronous to the externally provided clock source at the CLKIN pin with a frequency in the range of 5 MHz to 21 MHz. The time average of this serial bitstream output is proportional to the analog input voltage. The [Functional Block Diagram](#) section shows a detailed block diagram of the AMC1336. The 1.6-G Ω differential input resistance of the analog input stage supports low gain-error signal sensing in high-voltage applications using resistive dividers. The external clock input simplifies the synchronization of multiple current-sensing channels on the system level.

The silicon-dioxide (SiO₂)-based capacitive isolation barrier supports a high level of magnetic field immunity, as described in the [ISO72x Digital Isolator Magnetic-Field Immunity](#) application report, available for download at www.ti.com.

7.2 Functional Block Diagram

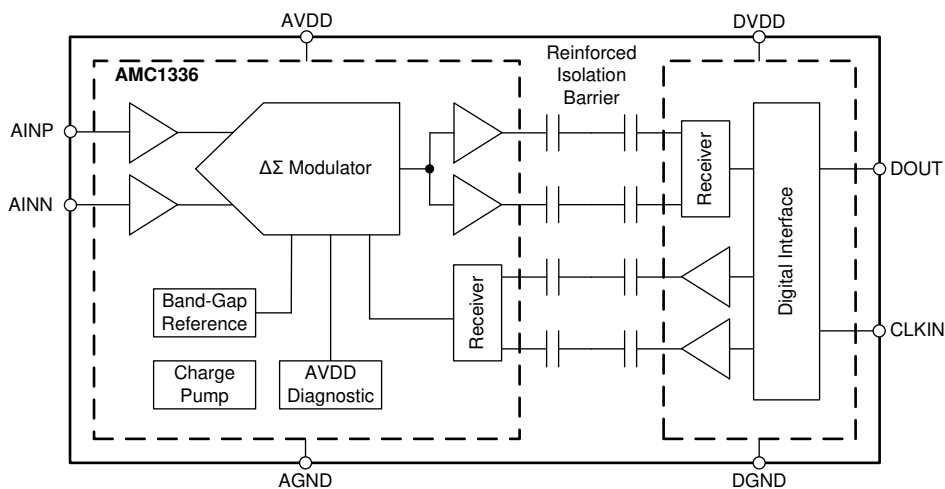

7.3 Feature Description

7.3.1 Analog Input

The AMC1336 incorporates front-end circuitry that contains an instrumentation amplifier, followed by a $\Delta\Sigma$ modulator. To support a bipolar input range with a unipolar high-side supply AVDD, the device uses a charge pump to simplify the overall system design and minimize circuit cost. For reduced offset and offset drift, the input buffer is chopper-stabilized with the switching frequency set at $f_{CLKIN} / 32$. [Figure 39](#) illustrates the spur created by the switching frequency.

Feature Description (continued)

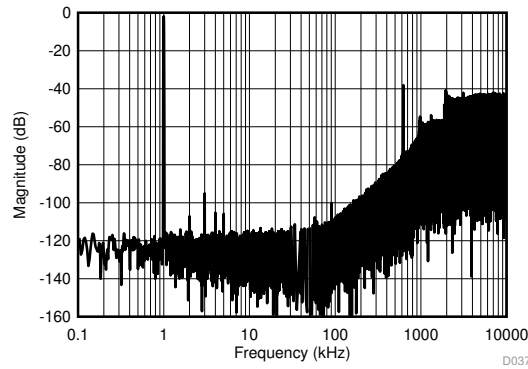

sinc^3 filter, $\text{OSR} = 1$, $f_{\text{CLKIN}} = 20 \text{ MHz}$, $f_{\text{IN}} = 1 \text{ kHz}$

Figure 39. Quantization Noise Shaping

The linearity and noise performance of the device are ensured only when the differential analog input voltage remains within the specified linear full-scale range (FSR), that is $\pm 1 \text{ V}$, and within the specified input common-mode range.

Figure 40 shows the specified common-mode input voltage that applies for the full-scale input voltage range as specified in this document.

If smaller input signals are used, the operational common-mode input voltage range widens. Figure 41 shows the common-mode input voltage that applies with no differential input signal; that is, when the voltage applied on AINP is equal to the voltage applied on AINN. The common-mode input voltage range scales with the actual differential input voltage between this range and the range in Figure 40.

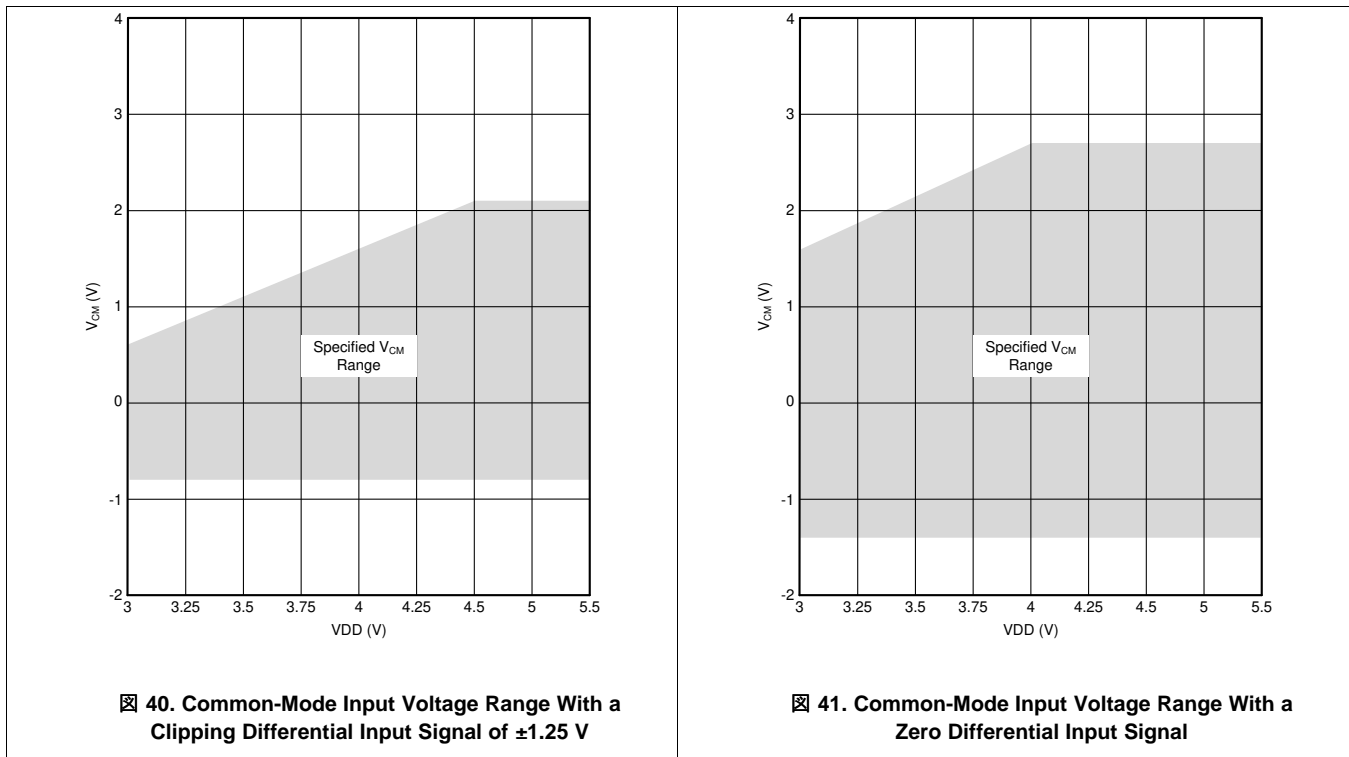

Figure 40. Common-Mode Input Voltage Range With a Clipping Differential Input Signal of $\pm 1.25 \text{ V}$

Figure 41. Common-Mode Input Voltage Range With a Zero Differential Input Signal

Feature Description (continued)

There are two restrictions on the analog input signals (AINP and AINN). First, if the input voltage exceeds the range $AGND - 5\text{ V}$ to $AVDD + 0.5\text{ V}$, the input current must be limited to 10 mA because the device input electrostatic discharge (ESD) diodes turn on. In addition, the linearity and noise performance of the device are ensured only when the differential analog input voltage remains within the specified linear full-scale range (FSR) and within the specified input common-mode range.

7.3.2 Modulator

The modulator implemented in the AMC1336, as conceptualized in [Figure 42](#), is a second-order, switched-capacitor, feed-forward $\Delta\Sigma$ modulator. The analog input voltage V_{IN} and the output V_5 of the 1-bit digital-to-analog converter (DAC) are subtracted, providing an analog voltage V_1 at the input of the first integrator stage. The output of the first integrator feeds the input of the second integrator stage, resulting in an output voltage V_3 that is differentiated with the input signal V_{IN} and the output of the first integrator V_2 . Depending on the polarity of the resulting voltage V_4 , the output of the comparator is changed. In this case, the 1-bit DAC responds on the next clock pulse by changing the associated analog output voltage V_5 , causing the integrators to progress in the opposite direction and forcing the value of the integrator output to track the average value of the input.

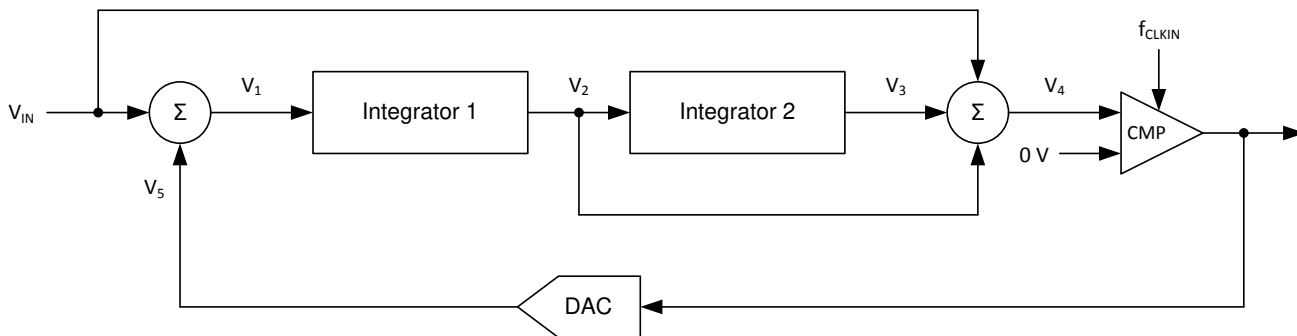

Figure 42. Block Diagram of a Second-Order Modulator

As depicted in [Figure 39](#), the modulator shifts the quantization noise to high frequencies. Therefore, use a low-pass digital filter at the output of the device to increase the overall performance. This filter is also used to convert from the 1-bit data stream at a high sampling rate into a higher-bit data word at a lower rate (decimation). TI's microcontroller families [TMS320F2807x](#) and [TMS320F2837x](#) offer a suitable programmable, hardwired filter structure termed a *sigma-delta filter module* (SDFM) optimized for usage with the AMC1336. Furthermore, the SD24_B converters on the [MSP430F677x](#) microcontrollers offer a path to directly access the integrated sinc filters for a simple system-level solution for multichannel, isolated current sensing. An additional option is to use a suitable application-specific device, such as the [AMC1210](#) (a four-channel digital sinc-filter). Alternatively, a field-programmable gate array (FPGA) can be used to implement the filter.

Feature Description (continued)

7.3.3 Isolation Channel Signal Transmission

The AMC1336 uses an on-off keying (OOK) modulation scheme to transmit the modulator output bitstream across the capacitive SiO₂-based isolation barrier. The transmitter modulates the bitstream at TX IN in [Figure 43](#) with an internally-generated, 480-MHz carrier across the isolation barrier to represent a digital *one* and sends a *no signal* to represent the digital *zero*. The receiver demodulates the signal after advanced signal conditioning and produces the output. The symmetrical design of each isolation channel improves the common-mode transient immunity (CMTI) performance and reduces the radiated emissions caused by the high-frequency carrier. [Figure 43](#) shows the block diagram of an isolation channel integrated in the AMC1336.

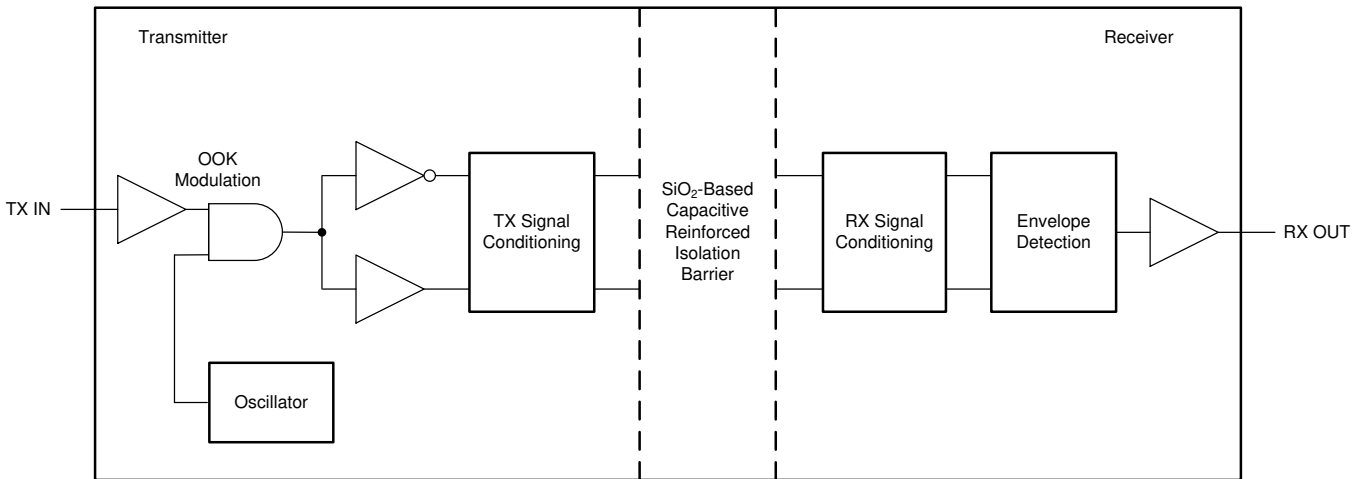

Figure 43. Block Diagram of an Isolation Channel

[Figure 44](#) shows the concept of the on-off keying scheme.

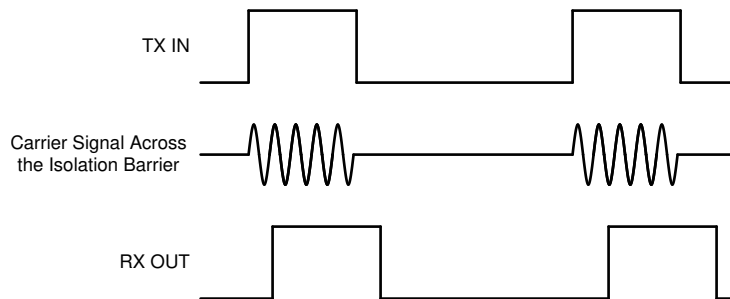

Figure 44. OOK-Based Modulation Scheme

Feature Description (continued)

7.3.4 Clock Input

The AMC1336 system clock is provided externally at the CLKIN pin. The clock signal must be applied continuously for proper device operation.

To support the bipolar input voltage range with a unipolar high-side supply AVDD, the AMC1336 includes a charge pump. This charge pump stops operating if the clock signal is below the specified frequency range or if the signal is paused or missing. In that case, the input bias current increases beyond the specified range and significantly reduces the input resistance of the device. When the clock signal is paused or missing, the modulator stops the analog signal conversion and the digital output signal remains frozen in the last logic state. When the clock signal is applied again after a pause, the internal analog circuitry biasing must settle for proper device performance. In this case, consider the t_{ASTART} specification in the [Switching Characteristics](#) table.

7.3.5 Digital Output

A differential input signal of 0 V ideally produces a stream of ones and zeros that are high 50% of the time. A differential input of 1 V produces a stream of ones and zeros that are high 90% of the time. With 16 bits of resolution, that percentage ideally corresponds to code 58982 (an unsigned code). A differential input of –1 V produces a stream of ones and zeros that are high 10% of the time and ideally results in code 6553 with 16-bit resolution. These input voltages are also the specified linear range of the AMC1336 with performance as specified in this document. If the input voltage value exceeds this range, the output of the modulator shows nonlinear behavior when the quantization noise increases. The output of the modulator clips with a stream of only zeros with an input less than or equal to –1.25 V or with a stream of only ones with an input greater than or equal to 1.25 V. In this case, however, the AMC1336 generates a single 1 (if the input is at negative full-scale) or 0 every 128 clock cycles to indicate proper device function (see the [AVDD Diagnostics and Fail-Safe Output](#) section for more details). [Figure 45](#) shows the input voltage versus the output modulator signal.

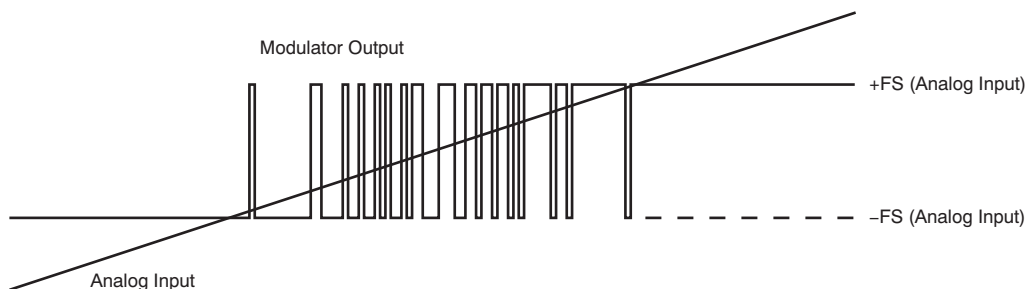



Figure 45. Analog Input versus the AMC1336 Modulator Output

[Equation 1](#) calculates the density of ones in the output bitstream for any input voltage value (with the exception of a full-scale input signal, as described in the [Output Behavior in Case of a Full-Scale Input](#) section):

$$\frac{V_{IN} + V_{Clipping}}{2 \times V_{Clipping}} \quad (1)$$

The modulator bitstream on the DOUT pin changes with the rising edge of the clock signal applied on the CLKIN pin. Use the rising edge of the clock to latch the modulator bitstream at the input of the digital filter device.

Feature Description (continued)

The AMC1336 features a slew-rate-controlled output stage that reduces the over- and undershoots of the output amplitude and radiated emissions of the DOUT line in the system.  46 and  47 show examples of rising and falling edges of DOUT with different capacitive loads.

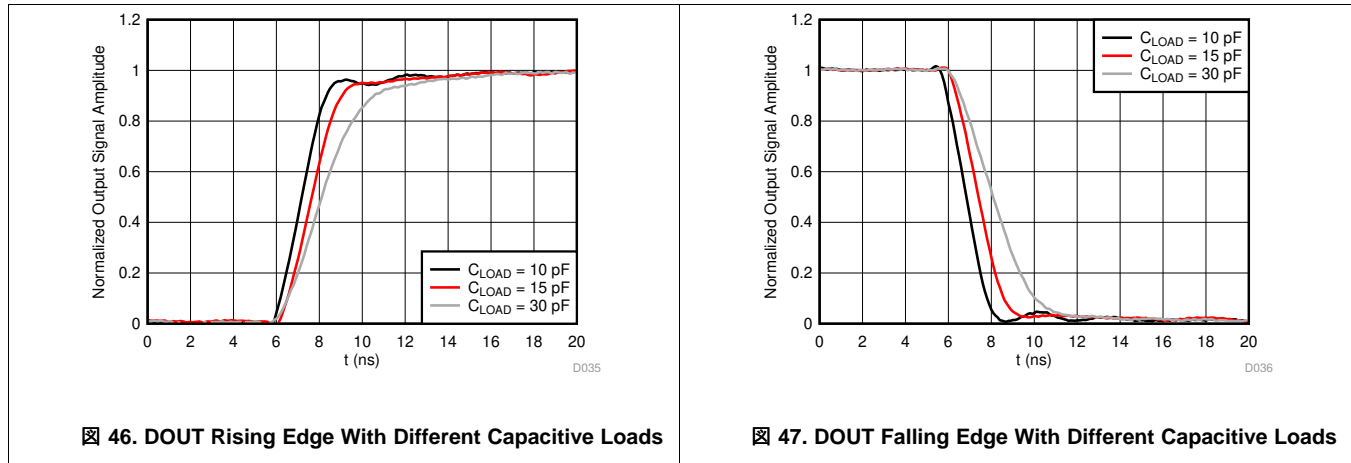

7.4 Device Functional Modes

The AMC1336 is operational when the power supplies AVDD and DVDD, and the clock signal CLKIN are applied, as specified in the [Recommended Operating Conditions](#) and [Switching Characteristics](#) tables.

7.4.1 Output Behavior in Case of a Full-Scale Input

Figure 48 shows that if a full-scale input signal is applied to the AMC1336 (that is, $V_{IN} \geq V_{Clipping}$), the device generates a single one or zero every 128 bits at DOUT, depending on the actual polarity of the signal being sensed. This feature can be used for advanced system-level diagnostics to differentiate between system failures caused by missing high-side supply AVDD or input overvoltage events.

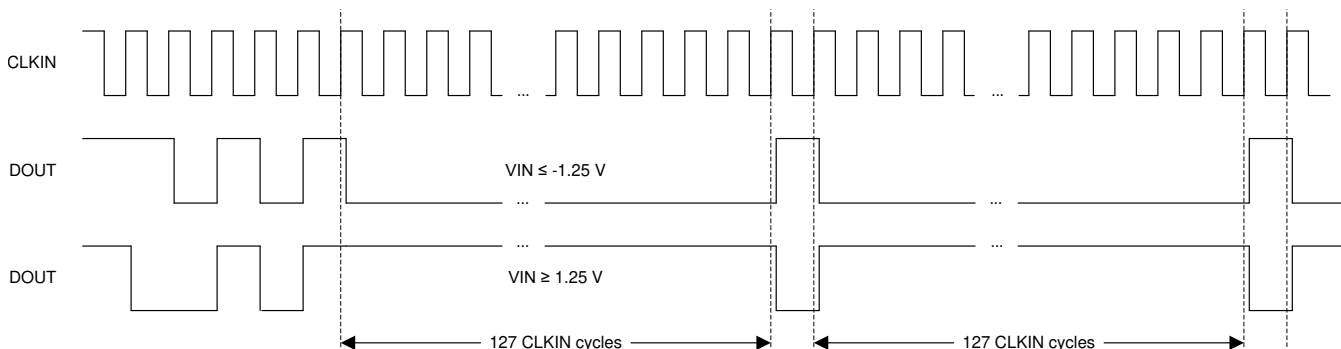

Figure 48. Out-of-Range Output of the AMC1336

7.4.2 AVDD Diagnostics and Fail-Safe Output

In the case of a missing high-side supply voltage AVDD, the output of a $\Delta\Sigma$ modulator is not defined and can cause a system malfunction. In systems with high safety requirements, this behavior is not acceptable. As shown in Figure 49, the AMC1336 implements an AVDD diagnostics and fail-safe output function that ensures that the output DOUT of the device offers a steady-state bitstream of logic 0's in case of a missing AVDD. Sample at least 128 CLKIN cycles in order to distinguish a missing AVDD condition from an input underrange condition.

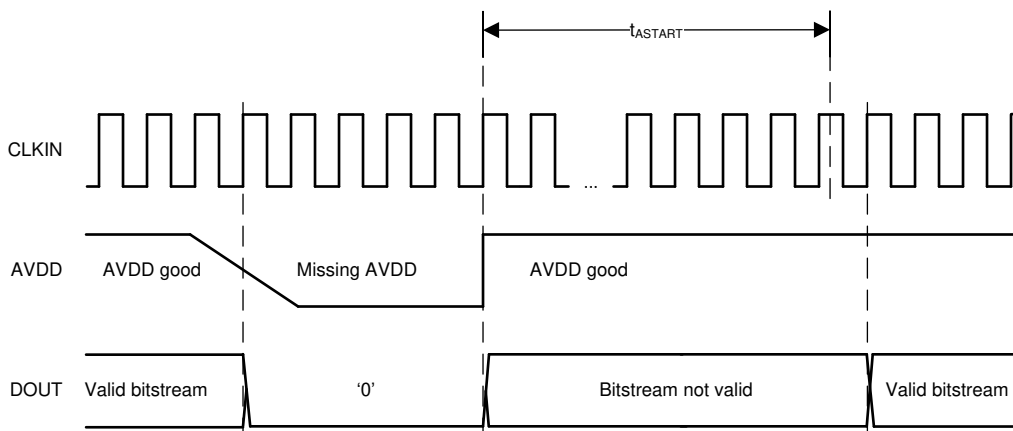

Figure 49. Fail-Safe Output of the AMC1336

8 Application and Implementation

注

Information in the following applications sections is not part of the TI component specification, and TI does not warrant its accuracy or completeness. TI's customers are responsible for determining suitability of components for their purposes. Customers should validate and test their design implementation to confirm system functionality.

8.1 Application Information

8.1.1 Digital Filter Usage

The modulator generates a bitstream that is processed by a digital filter to obtain a digital word similar to a conversion result of a conventional analog-to-digital converter (ADC). 式 2 shows a sinc³-type filter, which is a very simple filter that is built with minimal effort and hardware:

$$H(z) = \left(\frac{1 - z^{-\text{OSR}}}{1 - z^{-1}} \right)^3 \quad (2)$$

This filter provides the best output performance at the lowest hardware size (count of digital gates) for a second-order modulator. All the characterization in this document is also done with a sinc³ filter with an oversampling ratio (OSR) of 256 and an output word width of 16 bits.

An example code for implementing a sinc³ filter in an FPGA is discussed in the [Combining the ADS1202 with an FPGA Digital Filter for Current Measurement in Motor Control Applications](#) application note, available for download at www.ti.com.

8.2 Typical Application

Isolated $\Delta\Sigma$ modulators are widely used in frequency inverter designs because of their high AC and DC performance. Frequency inverters are critical parts of industrial motor drives, photovoltaic inverters (string and central inverters), uninterruptible power supplies (UPS), and other industrial applications.

Figure 50 shows a simplified schematic of a frequency inverter application with the AMC1336 used for the DC-link and output phase voltage sensing. In this example, the ground reference point for the microcontroller is not connected by any means to the power stage. This configuration is usually the case in systems with the microcontroller located on a dedicated control card or PCB.

Current feedback is performed with shunt resistors (R_{SHUNT}) and TI's AMC1306M25 isolated modulators. Depending on the system design, either all three or only two motor phase currents are sensed.

Depending on the overall digital processing power requirements and with a total of eight $\Delta\Sigma$ modulator bitstreams to be processed by the microcontroller (MCU), a derivative from either the low-cost single-core TMS320F2807x or the dual-core TMS320F2837x families can be used in this application.

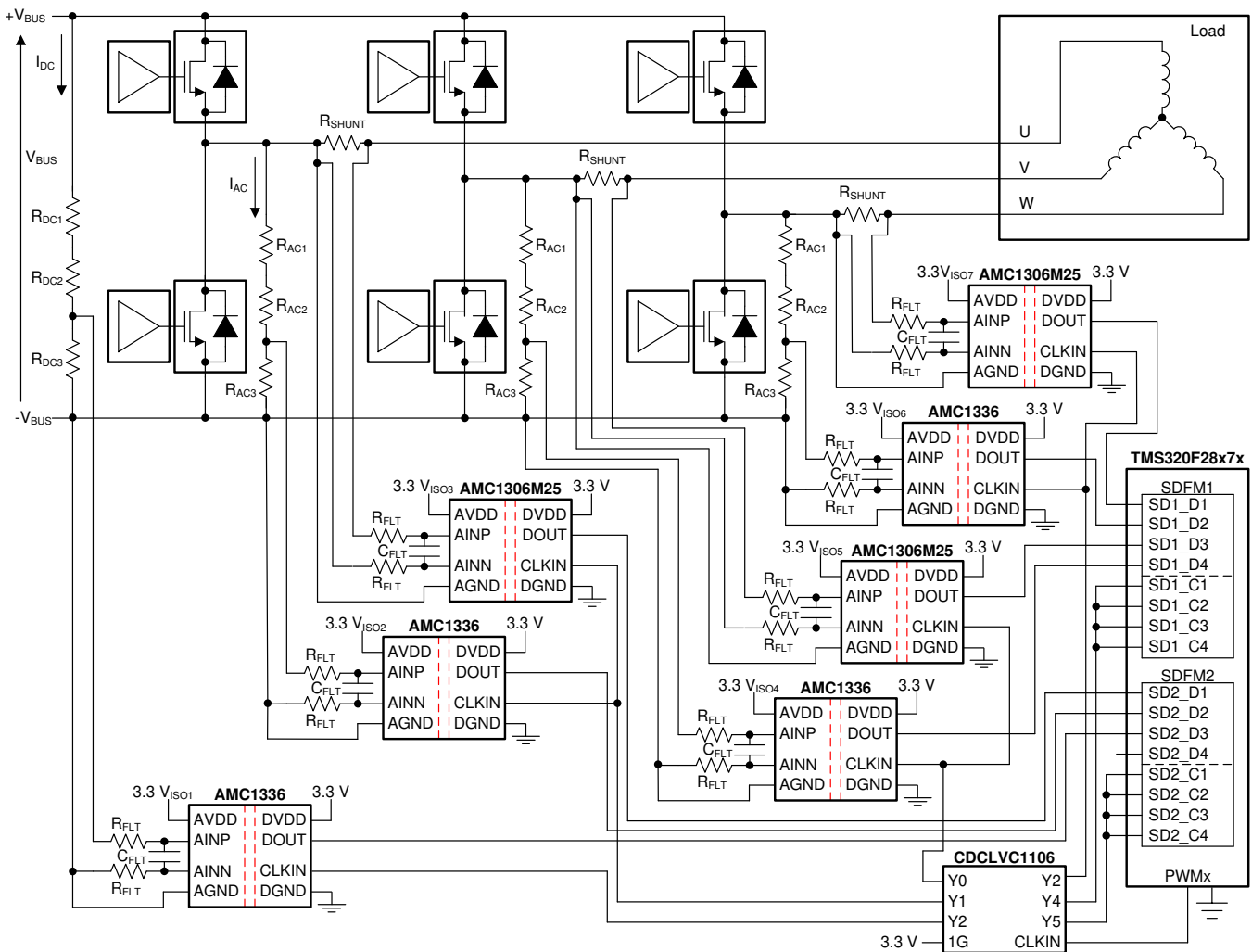

Figure 50. The AMC1336 in a Frequency Inverter Application

Typical Application (continued)

Figure 51 shows an additional example of the AMC1336 used for input phase and DC-link voltage sensing. Also in this case, the microcontroller is located on a dedicated control card and the AMC1306M25 is used for shunt-based current sensing.

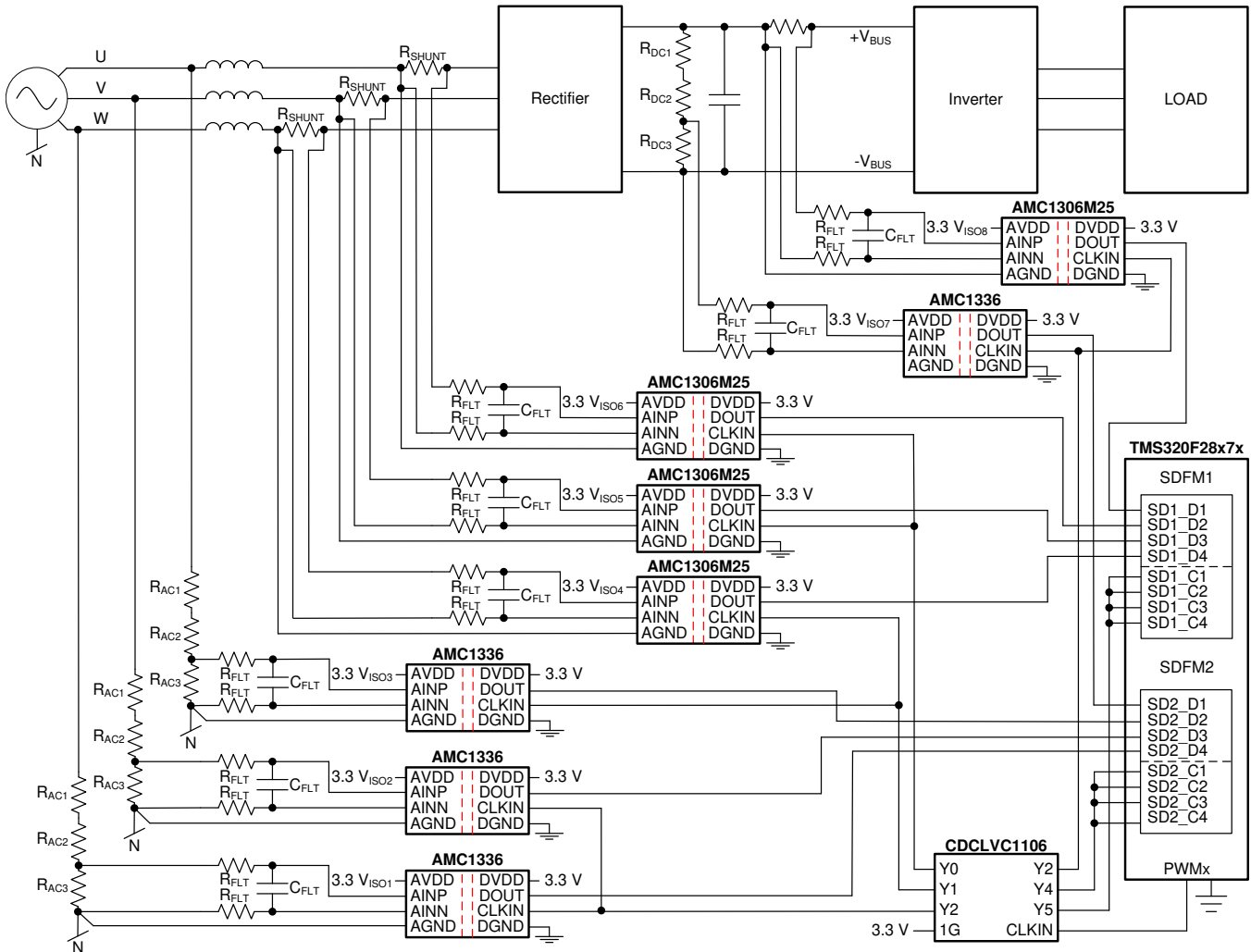

Figure 51. Input Phase Voltage Sensing Application with AMC1336

Typical Application (continued)

8.2.1 Design Requirements

表 1 lists the parameters for this typical application.

表 1. Design Requirements

PARAMETER	VALUE
Supply voltage	3.3 V
Voltage drop across the sensing resistor R_{DC1} for a linear response	1 V (maximum)
Voltage drop across the sensing resistors R_{ACx} for a linear response	± 1 V (maximum)
Current through the sensing resistors R_{ACx}	± 100 μ A (maximum)

8.2.2 Detailed Design Procedure

Use Ohm's Law to calculate the minimum total resistance of the resistive dividers to limit the cross current to the desired values:

- For the voltage sensing on the DC bus: $R_{DC1} + R_{DC2} + R_{DC3} = V_{BUS} / I_{DC}$
- For the voltage sensing on the output phases U, V, and W: $R_{AC1} + R_{AC2} + R_{AC3} = V_{PHASE (max)} / I_{AC}$

Consider the following two restrictions to choose the proper value of the resistors R_{DC3} and R_{AC3} :

- The voltage drop caused by the nominal voltage range of the system must not exceed the recommended input voltage range of the AMC1336: $V_{XC3} \leq V_{FSR}$
- The voltage drop caused by the maximum allowed system overvoltage must not exceed the input voltage that causes a clipping output: $V_{XC3} \leq V_{Clipping}$

Use similar approach for calculation of the shunt resistor values R_{SHUNT} and see the [AMC1306M25 data sheet](#) for further details.

表 2 lists examples of nominal E96-series (1% accuracy) resistor values for systems using 600 V and 800 V on the DC bus.

表 2. Resistor Value Examples for DC Bus Sensing

PARAMETER	600-V DC BUS	800-V DC BUS
Resistive divider resistor R_{DC1}	3.01 M Ω	4.22 M Ω
Resistive divider resistor R_{DC2}	3.01 M Ω	4.22 M Ω
Sense resistor R_{DC3}	10 k Ω	10.5 k Ω
Resulting current through resistive divider I_{DC}	99.5 μ A	94.7 μ A
Resulting voltage drop on sense resistor V_{RDC3}	0.995 V	0.994 V

表 3 lists examples of nominal E96-series (1% accuracy) resistor values for systems using 230 V and 690 V on the input or output phases.

表 3. Resistor Value Examples for Phase Voltage Sensing

PARAMETER	± 400 -V _{AC} PHASE	± 690 -V _{AC} PHASE
Resistive divider resistor R_{AC1}	2.0 M Ω	3.48 M Ω
Resistive divider resistor R_{AC2}	2.0 M Ω	3.48 M Ω
Sense resistor R_{AC3}	10.0 k Ω	10.0 k Ω
Resulting current through resistive divider I_{AC}	99.8 μ A	99.0 μ A
Resulting voltage drop on sense resistor V_{RAC3}	± 0.998 V	± 0.990 V

Use a power supply with a nominal voltage of 3.3 V for DVDD to directly connect all modulators to the microcontroller.

For modulator output bitstream filtering, a device from TI's [TMS320F2807x](#) family of low-cost microcontrollers (MCUs) or [TMS320F2837x](#) family of dual-core MCUs is recommended. These MCU families support up to eight channels of dedicated hardwired filter structures called sigma-delta filter modules (SDFMs) that significantly simplify system level design by offering two filtering paths per channel: one providing high accuracy results for the control loop and one that offers a fast response path for overcurrent detection. Use one of the pulse-width modulation (PWM) sources inside the MCU to generate the clock for the modulators and for easy synchronization of all feedback signals and the switching control of the gate drivers.

The application examples in [Figure 50](#) and [Figure 51](#) use a clock buffer to distribute the clock reference signal generated on one of the PWMx outputs of the MCU to all modulators used in the circuit and as a reference for the digital filters in the MCU. In this example, TI's [CDCLVC1106](#) is used for this purpose. Each CDCLVC1106 output can drive a load of 8 pF that is sufficient to drive up to two modulator and up to four SDFM clock inputs.

8.2.3 Application Curve

The effective number of bits (ENOB) is often used to compare the performance of ADCs and $\Delta\Sigma$ modulators. [Figure 52](#) shows the ENOB of the AMC1336 with different oversampling ratios. In this document, this number is calculated from the SINAD by using following equation: $SINAD = 1.76 \text{ dB} + 6.02 \times ENOB$.

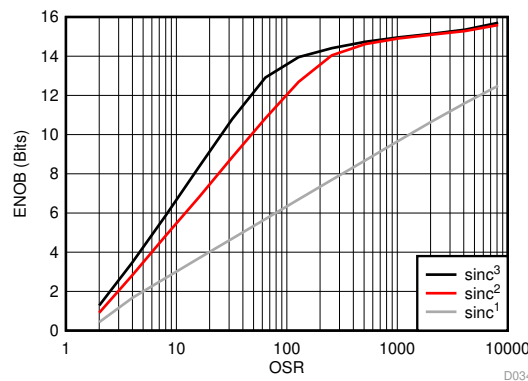

Figure 52. Measured Effective Number of Bits versus Oversampling Ratio

8.2.4 What to Do and What Not to Do

Do not leave the inputs of the AMC1336 unconnected (floating) when the device is powered up. If either modulator input is left floating, the input bias current can drive this input beyond the specified common-mode input voltage range. If both inputs are beyond that range, the gain of the front-end diminishes and the output bitstream is not valid.

9 Power Supply Recommendations

In a typical frequency-inverter application, the high-side power supply (AVDD) for the AMC1336 is generated from the controller-side supply (DVDD) of the device by an isolated dc/dc converter circuit. [Figure 53](#) shows a low-cost solution based on the push-pull driver [SN6501](#) and a transformer that supports the desired isolation voltage ratings. TI recommends using a low-ESR decoupling capacitor of 0.1 μF and an additional capacitor of minimum 1 μF for both supplies of the AMC1336. Place these decoupling capacitors as close as possible to the device power-supply pins to minimize supply current loops and electromagnetic emissions.

The AMC1336 does not require any specific power up sequencing. Consider the analog settling time t_{ASTART} as specified in the [Switching Characteristics](#) table after ramp up of the AVDD high-side supply.

Connect the high-side ground pin AGND of the AMC1336 to one of the analog inputs AINx to avoid common-mode input voltage range violations.

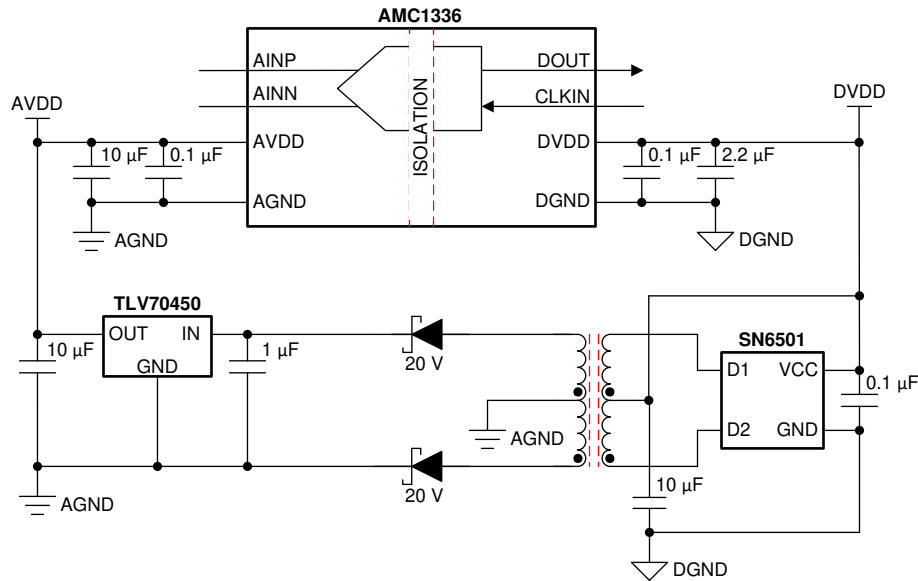



Figure 53. Decoupling the AMC1336

10 Layout

10.1 Layout Guidelines

 54 shows an example layout that is used on the AMC1336 evaluation module. For best performance, place the smaller 0.1- μ F decoupling capacitors (C7 and C9) as close as possible to the AMC1336 power-supply pins, followed by the additional C1 and C11 capacitors with a minimum value of 1 μ F. The resistors and capacitors used for the analog input filter (R1, R2, C4, C5, and C8) are placed next to the decoupling capacitors. Use 1206-size, SMD-type, ceramic decoupling capacitors and route the traces to the AINx pins underneath. Connect the supply voltage sources in a way that allows the supply current to flow through the pads of the decoupling capacitors before powering the device.

Consider use of RC filters on the digital clock and data lines to reduce reflections and slew rate that cause radiated emissions. The AMC1336 evaluation module offers placeholders for RC filters (termed R8 and C13 in  54) for the CLKIN line, and R7 and C12 for the DOUT line.

10.2 Layout Example

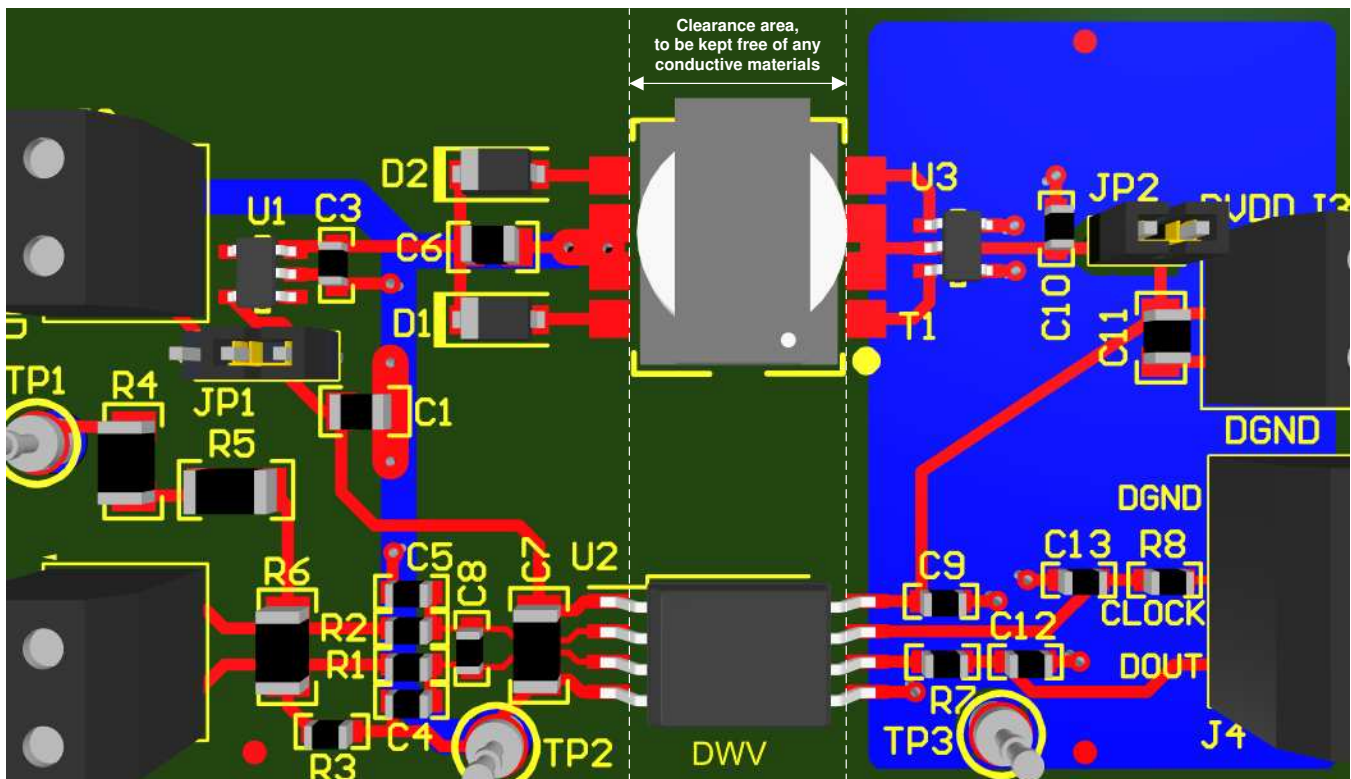

 54. Recommended Layout of the AMC1336

11 デバイスおよびドキュメントのサポート

11.1 デバイス・サポート

11.1.1 デバイスの項目表記

11.1.1.1 絶縁の用語集

『絶縁の用語集』を参照してください。

11.2 ドキュメントのサポート

11.2.1 関連資料

関連資料については、以下を参照してください。

- テキサス・インスツルメンツ、『TMS320F28004x Piccolo™ マイクロコントローラ』データシート
- テキサス・インスツルメンツ、『TMS320F2807x Piccolo™ マイクロコントローラ』データシート
- テキサス・インスツルメンツ、『TMS320F2837xD デュアル・コア Delfino™ マイクロコントローラ』データシート
- テキサス・インスツルメンツ、『ISO72x デジタルアイソレータ磁界耐性』
- テキサス・インスツルメンツ、『MSP430F677x, MSP430F676x, MSP430F674x 多相メータリング SoC』データシート
- テキサス・インスツルメンツ、『AMC1210 2次デルタ-シグマ変調器用のクワッド・デジタル・フィルタ』データシート
- テキサス・インスツルメンツ、『ADS1202とFPGA デジタル・フィルタとの組み合わせによるモータ制御アプリケーションでの電流測定』アプリケーション・レポート
- テキサス・インスツルメンツ、『AMC1306x 高CMTI、小型、高精度の強化絶縁デルタ-シグマ変調器』データシート
- テキサス・インスツルメンツ、『CDCLVC11xx 3.3Vおよび2.5V LVCMOS 高性能クロック・バッファ・ファミリ』データシート
- テキサス・インスツルメンツ、『SN6501 絶縁電源用の変圧器ドライバ』データシート
- テキサス・インスツルメンツ、『AMC1303, AMC1306, and AMC1336 Evaluation Module』ユーザー・ガイド (英語)

11.3 ドキュメントの更新通知を受け取る方法

ドキュメントの更新についての通知を受け取るには、ti.comのデバイス製品フォルダを開いてください。右上の「アラートを受け取る」をクリックして登録すると、変更されたすべての製品情報に関するダイジェストを毎週受け取れます。変更の詳細については、修正されたドキュメントに含まれている改訂履歴をご覧ください。

11.4 コミュニティ・リソース

[TI E2E™ support forums](#) are an engineer's go-to source for fast, verified answers and design help — straight from the experts. Search existing answers or ask your own question to get the quick design help you need.

Linked content is provided "AS IS" by the respective contributors. They do not constitute TI specifications and do not necessarily reflect TI's views; see TI's [Terms of Use](#).

11.5 商標

E2E is a trademark of Texas Instruments.
All other trademarks are the property of their respective owners.

11.6 静電気放電に関する注意事項



すべての集積回路は、適切なESD保護方法を用いて、取扱いと保存を行うようにして下さい。

静電気放電はわずかな性能の低下から完全なデバイスの故障に至るまで、様々な損傷を与えます。高精度の集積回路は、損傷に対して敏感であり、極めてわずかなパラメータの変化により、デバイスに規定された仕様に適合しなくなる場合があります。

11.7 Glossary

[SLYZ022](#) — *TI Glossary*.

This glossary lists and explains terms, acronyms, and definitions.

12 メカニカル、パッケージ、および注文情報

以降のページには、メカニカル、パッケージ、および注文に関する情報が記載されています。この情報は、そのデバイスについて利用可能な最新のデータです。このデータは予告なく変更されることがあり、ドキュメントが改訂される場合もあります。本データシートのブラウザ版を使用されている場合は、画面左側の説明をご覧ください。

PACKAGING INFORMATION

Orderable part number	Status (1)	Material type (2)	Package Pins	Package qty Carrier	RoHS (3)	Lead finish/ Ball material (4)	MSL rating/ Peak reflow (5)	Op temp (°C)	Part marking (6)
AMC1336DWV	Active	Production	SOIC (DWV) 8	64 TUBE	Yes	NIPDAU	Level-3-260C-168 HR	-40 to 125	AMC1336
AMC1336DWV.A	Active	Production	SOIC (DWV) 8	64 TUBE	Yes	NIPDAU	Level-3-260C-168 HR	-40 to 125	AMC1336
AMC1336DWV.B	Active	Production	SOIC (DWV) 8	64 TUBE	-	Call TI	Call TI	-40 to 125	
AMC1336DWVR	Active	Production	SOIC (DWV) 8	1000 LARGE T&R	Yes	NIPDAU	Level-3-260C-168 HR	-40 to 125	AMC1336
AMC1336DWVR.A	Active	Production	SOIC (DWV) 8	1000 LARGE T&R	Yes	NIPDAU	Level-3-260C-168 HR	-40 to 125	AMC1336
AMC1336DWVR.B	Active	Production	SOIC (DWV) 8	1000 LARGE T&R	-	Call TI	Call TI	-40 to 125	

(1) **Status:** For more details on status, see our [product life cycle](#).

(2) **Material type:** When designated, preproduction parts are prototypes/experimental devices, and are not yet approved or released for full production. Testing and final process, including without limitation quality assurance, reliability performance testing, and/or process qualification, may not yet be complete, and this item is subject to further changes or possible discontinuation. If available for ordering, purchases will be subject to an additional waiver at checkout, and are intended for early internal evaluation purposes only. These items are sold without warranties of any kind.

(3) **RoHS values:** Yes, No, RoHS Exempt. See the [TI RoHS Statement](#) for additional information and value definition.

(4) **Lead finish/Ball material:** Parts may have multiple material finish options. Finish options are separated by a vertical ruled line. Lead finish/Ball material values may wrap to two lines if the finish value exceeds the maximum column width.

(5) **MSL rating/Peak reflow:** The moisture sensitivity level ratings and peak solder (reflow) temperatures. In the event that a part has multiple moisture sensitivity ratings, only the lowest level per JEDEC standards is shown. Refer to the shipping label for the actual reflow temperature that will be used to mount the part to the printed circuit board.

(6) **Part marking:** There may be an additional marking, which relates to the logo, the lot trace code information, or the environmental category of the part.

Multiple part markings will be inside parentheses. Only one part marking contained in parentheses and separated by a "~" will appear on a part. If a line is indented then it is a continuation of the previous line and the two combined represent the entire part marking for that device.

Important Information and Disclaimer:The information provided on this page represents TI's knowledge and belief as of the date that it is provided. TI bases its knowledge and belief on information provided by third parties, and makes no representation or warranty as to the accuracy of such information. Efforts are underway to better integrate information from third parties. TI has taken and continues to take reasonable steps to provide representative and accurate information but may not have conducted destructive testing or chemical analysis on incoming materials and chemicals. TI and TI suppliers consider certain information to be proprietary, and thus CAS numbers and other limited information may not be available for release.

In no event shall TI's liability arising out of such information exceed the total purchase price of the TI part(s) at issue in this document sold by TI to Customer on an annual basis.

OTHER QUALIFIED VERSIONS OF AMC1336 :

- Automotive : [AMC1336-Q1](#)

NOTE: Qualified Version Definitions:

- Automotive - Q100 devices qualified for high-reliability automotive applications targeting zero defects

TAPE AND REEL INFORMATION

QUADRANT ASSIGNMENTS FOR PIN 1 ORIENTATION IN TAPE

*All dimensions are nominal

Device	Package Type	Package Drawing	Pins	SPQ	Reel Diameter (mm)	Reel Width W1 (mm)	A0 (mm)	B0 (mm)	K0 (mm)	P1 (mm)	W (mm)	Pin1 Quadrant
AMC1336DWVR	SOIC	DWV	8	1000	330.0	16.4	12.15	6.2	3.05	16.0	16.0	Q1

TAPE AND REEL BOX DIMENSIONS

*All dimensions are nominal

Device	Package Type	Package Drawing	Pins	SPQ	Length (mm)	Width (mm)	Height (mm)
AMC1336DWVR	SOIC	DWV	8	1000	353.0	353.0	32.0

TUBE

*All dimensions are nominal

Device	Package Name	Package Type	Pins	SPQ	L (mm)	W (mm)	T (μm)	B (mm)
AMC1336DWV	DWV	SOIC	8	64	505.46	13.94	4826	6.6
AMC1336DWV.A	DWV	SOIC	8	64	505.46	13.94	4826	6.6

PACKAGE OUTLINE

DWV0008A



SOIC - 2.8 mm max height

SOIC

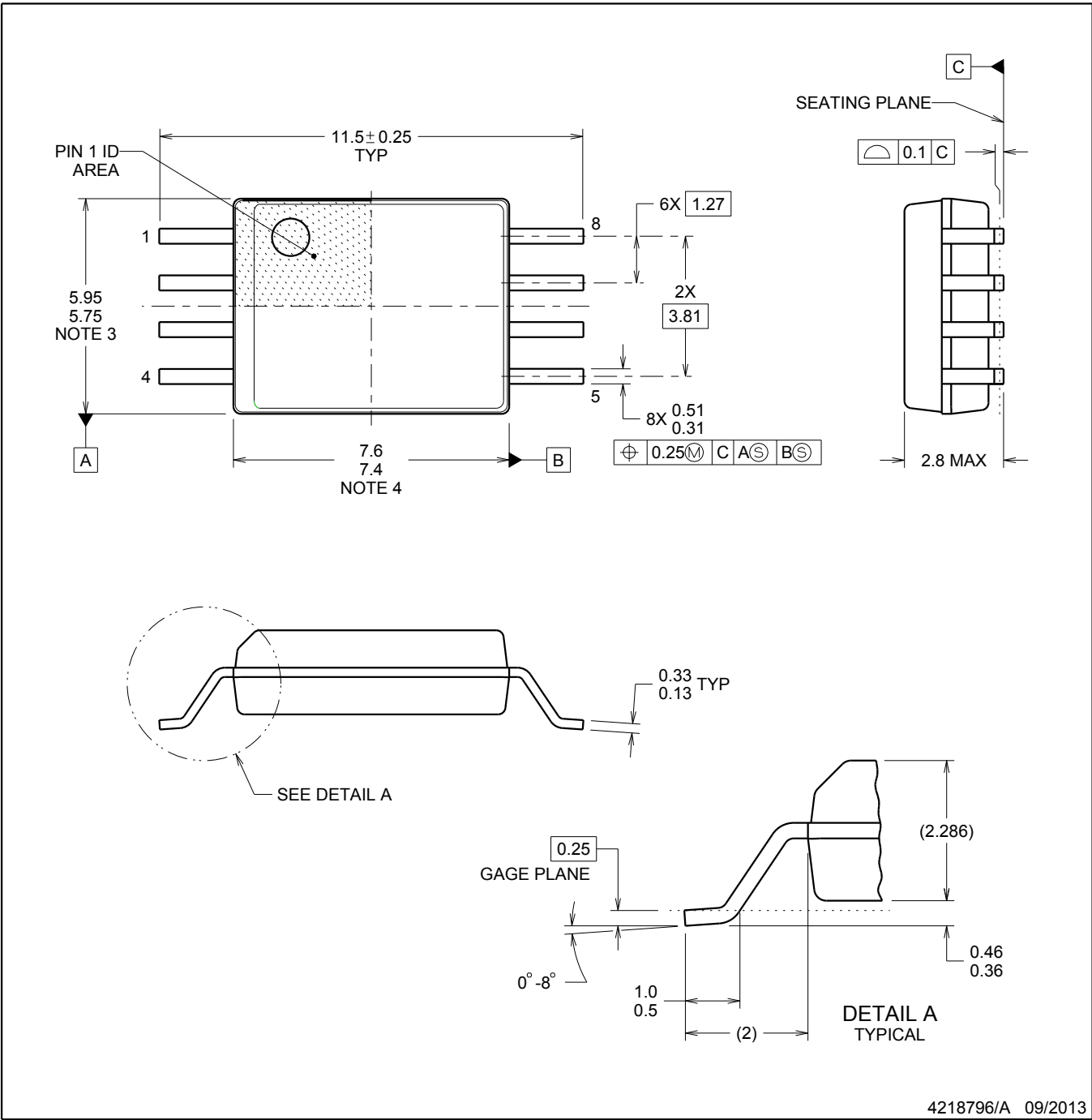

4218796/A 09/2013

NOTES:

1. All linear dimensions are in millimeters. Dimensions in parenthesis are for reference only. Dimensioning and tolerancing per ASME Y14.5M.
2. This drawing is subject to change without notice.
3. This dimension does not include mold flash, protrusions, or gate burrs. Mold flash, protrusions, or gate burrs shall not exceed 0.15 mm, per side.
4. This dimension does not include interlead flash. Interlead flash shall not exceed 0.25 mm, per side.

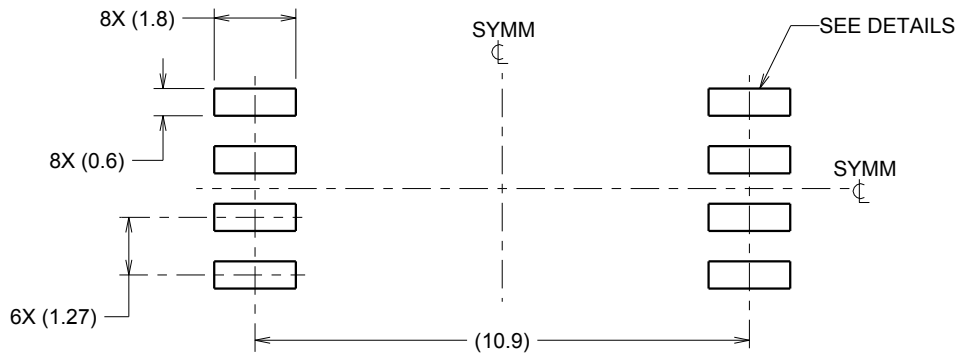

LAND PATTERN EXAMPLE
9.1 mm NOMINAL CLEARANCE/CREEPAGE
SCALE:6X

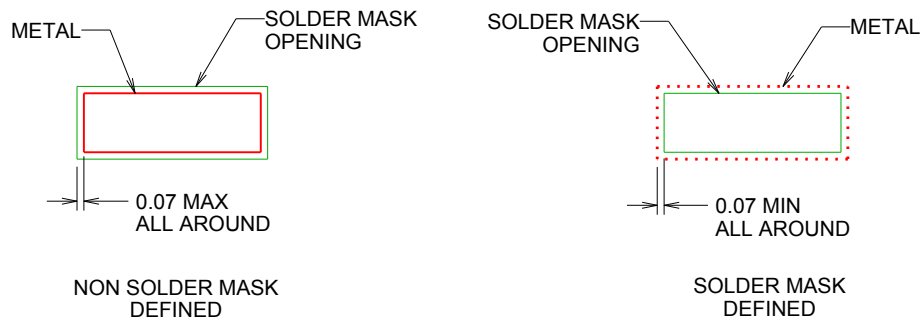

SOLDER MASK DETAILS

4218796/A 09/2013

NOTES: (continued)

- 5. Publication IPC-7351 may have alternate designs.
- 6. Solder mask tolerances between and around signal pads can vary based on board fabrication site.

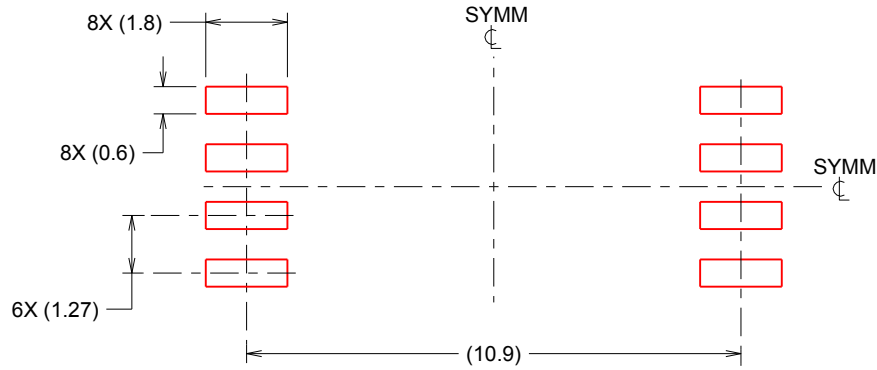

SOLDER PASTE EXAMPLE
 BASED ON 0.125 mm THICK STENCIL
 SCALE:6X

4218796/A 09/2013

NOTES: (continued)

- 7. Laser cutting apertures with trapezoidal walls and rounded corners may offer better paste release. IPC-7525 may have alternate design recommendations.
- 8. Board assembly site may have different recommendations for stencil design.

重要なお知らせと免責事項

TI は、技術データと信頼性データ(データシートを含みます)、設計リソース(リファレンス デザインを含みます)、アプリケーションや設計に関する各種アドバイス、Web ツール、安全性情報、その他のリソースを、欠陥が存在する可能性のある「現状のまま」提供しており、商品性および特定目的に対する適合性の黙示保証、第三者の知的財産権の非侵害保証を含むいかなる保証も、明示的または黙示的にかかわらず拒否します。

これらのリソースは、TI 製品を使用する設計の経験を積んだ開発者への提供を意図したものです。(1) お客様のアプリケーションに適した TI 製品の選定、(2) お客様のアプリケーションの設計、検証、試験、(3) お客様のアプリケーションに該当する各種規格や、その他のあらゆる安全性、セキュリティ、規制、または他の要件への確実な適合に関する責任を、お客様のみが単独で負うものとし、

上記の各種リソースは、予告なく変更される可能性があります。これらのリソースは、リソースで説明されている TI 製品を使用するアプリケーションの開発の目的でのみ、TI はその使用をお客様に許諾します。これらのリソースに関して、他の目的で複製することや掲載することは禁止されています。TI や第三者の知的財産権のライセンスが付与されている訳ではありません。お客様は、これらのリソースを自身で使用した結果発生するあらゆる申し立て、損害、費用、損失、責任について、TI およびその代理人を完全に補償するものとし、TI は一切の責任を拒否します。

TI の製品は、[TI の販売条件](#)、[TI の総合的な品質ガイドライン](#)、[ti.com](#) または TI 製品などに関連して提供される他の適用条件に従い提供されます。TI がこれらのリソースを提供することは、適用される TI の保証または他の保証の放棄の拡大や変更を意味するものではありません。TI がカスタム、またはカスタマー仕様として明示的に指定していない限り、TI の製品は標準的なカタログに掲載される汎用機器です。

お客様がいかなる追加条項または代替条項を提案する場合も、TI はそれらに異議を唱え、拒否します。

Copyright © 2025, Texas Instruments Incorporated

最終更新日：2025 年 10 月