

# EVM User's Guide: TPLD1202-RWS-EVM

## TPLD1202RWS 和 TPLD1202RWB 评估模块



### 说明

借助 TPLD1202-RWS-EVM，用户无需将 TPLD1202RWS 和 TPLD1202RWB 器件焊接到电路板上即可对器件进行配置。用户可以使用 **InterConnect Studio (ICS)** 进行快速评估、开发、仿真和编程。编程完成后，即可从插座移除 TPLD 器件并将其置于用户的系统中。用户可以在不对电路板进行任何更改的情况下对任一器件进行编程。

### 开始使用

1. 订购 **TPLD1202-RWS-EVM** 和 **TPLD-PROGRAM**
2. 下载最新版本的 **InterConnect Studio (ICS)**
3. 使用 **TPLD-PROGRAM** 套件随附的电缆连接系统
4. 将未编程的 TPLD1202RWS 或 TPLD1202RWB 插入插座中，并使用 ICS 进行配置

### 特性

- 可使用 RWS/RWB 插座轻松对 TPLD1202RWS 和 TPLD1202RWB 进行编程和评估
- 通过输入按钮、电位器和输出 LED 可实现快速评估
- 可通过接头引脚和测试点来连接定制系统
- 使用标准键控 14 引脚电缆与 TPLD-PROGRAM 连接

### 应用

- 工厂自动化和控制
- 通信设备
- 零售自动化和支付
- 测试和测量
- 专业音频、视频和标牌
- 个人电子产品

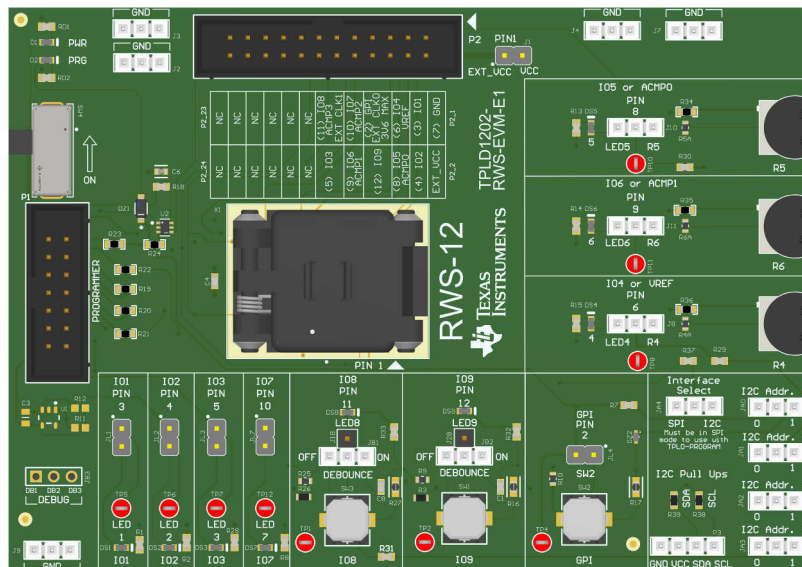

## 1 评估模块概述

### 1.1 简介

本用户指南包含 TPLD1202RWS 和 TPLD1202RWB 评估模块 (EVM) 的支持文档。本指南介绍了如何设置和配置 EVM、如何将 EVM 与 TPLD-PROGRAM 板结合使用，以及如何使用 InterConnect Studio 配置 TPLD1202。此外，本指南还介绍了 TPLD1202-RWS-EVM 的印刷电路板 (PCB) 布局布线、原理图和物料清单 (BOM)。

TPLD1202RWS 和 TPLD1202RWB 属于 TI 可编程逻辑器件 (TPLD) 系列，该系列器件采用具有组合逻辑、时序逻辑和混合信号功能的多功能可编程逻辑 IC，可提供集成、紧凑的低功耗设计来实现常见系统功能（例如时序延迟、电压监测器、系统复位、电源序列发生器以及 I/O 扩展器等）。

#### 备注

为了对器件进行编程，需要 TPLD-PROGRAM 板和 InterConnect Studio。

TI 仅支持使用 TPLD-PROGRAM 套件中提供的电缆连接 EVM 和编程器板。

### 1.2 套件内容

表 1-1. TPLD1202-RWS-EVM 套件内容

条目	说明	数量
TPLD1202-RWS-EVM	PCB	1
TPLD1202RWS 或 TPLD1202RWB	12 引脚 TI 可编程逻辑器件	5
快速入门指南	系统设置指南	1

### 1.3 规格

参数	条件	最小值	典型值	最大值	单位
Vcc	由编程器提供支持		3.3		V
Vcc	外部电源	1.71		5.5	V
Vi	每引脚输入	0		Vcc	V
Vo	每引脚输出	0		Vcc	V
GPI	输入	0		Vcc	V

### 1.4 器件信息

TPLD1202 是 TI 可编程逻辑器件 (TPLD) 系列器件中的一款，具有多用途可编程逻辑 IC，支持组合逻辑、顺序逻辑和混合信号功能。TPLD 提供了集成、紧凑、低功耗的设计方案来实现常见的系统功能，例如时序延迟、电压监控器、系统复位、电源序列发生器、I/O 扩展器等。此款成本优化型器件在小型封装中提供了一组丰富的功能，支持从 -40°C 到 125°C 的工作温度范围，并可在 1.71V 至 5.5V 的电源电压范围内运行。

## 2 硬件

### 2.1 功能块

本节介绍了 TPLD1202-RWS-EVM 的不同功能块。

#### 2.1.1 测试点

插槽式 TPLD1202RWS 或 TPLD1202RWB 器件的每个 GPIO 和 GPI 引脚均直接连接到测试点，方便用户使用器件的每个引脚进行探测和测试。各引脚按如下方式连接到测试点：

表 2-1. 测试点

RWS 引脚编号	RWB 引脚编号	IO 名称	测试点
11	1	IO8	TP1
12	2	IO9	TP2
2	4	GPI	TP4
3	5	IO1	TP5
4	6	IO2	TP6
5	7	IO3	TP7
6	8	IO4	TP8
8	10	IO5	TP10
9	11	IO6	TP11
10	12	IO7	TP12

每个测试点均直接连接到相应的引脚，因此任何断开的接头引脚都不会从引脚断开测试点。

#### 2.1.2 编程器接头块 (P1)

编程器接头块接受用于将 TPLD1202-RWS-EVM 连接到 TPLD-PROGRAM 的 14 位电缆。TI 建议使用此接头仅通过 TPLD-PROGRAM 套件随附的电缆连接到 TPLD-PROGRAM。该接头为键控接头，因此 14 位电缆只在键槽朝向正确方向时才能插入外壳。要将 TPLD1202-RWS-EVM 连接到 TPLD-PROGRAM，请按照节 3.2 中的步骤操作。

SW4 将编程器接头的 3V3 线路连接到 EVM 的 VCC 线路。通过 TPLD-PROGRAM 为 EVM 供电时，3V3 线路必须处于 ON 位置。

#### 2.1.3 外部连接接头块

使用 P2 接头块将 TPLD1202-RWS-EVM 与外部系统连接。根据 EVM 丝印上的指南，将 TPLD 引脚与外部系统连接，从而支持在客户系统中进行原型设计和测试。使用 P2 接头块为 TPLD 供电时，SW4 必须处于 OFF 位置，并在 J1 上放置一个分流器，将外部 VCC 电源从 P2 (VCC\_EXT) 连接到 EVM 的 VCC 网络。TI 建议不要将电路板同时连接到外部系统和 TPLD-PROGRAM，以避免损坏 TPLD-PROGRAM 和外部系统的风险。



图 2-1. P2 和 J1 接头

### 2.1.4 GPI 保护块

在永久编程过程中，对 TPLD 的 GPI 引脚施加 8V 电压。该电路可防止 P2 上的电压超过 3.3V。

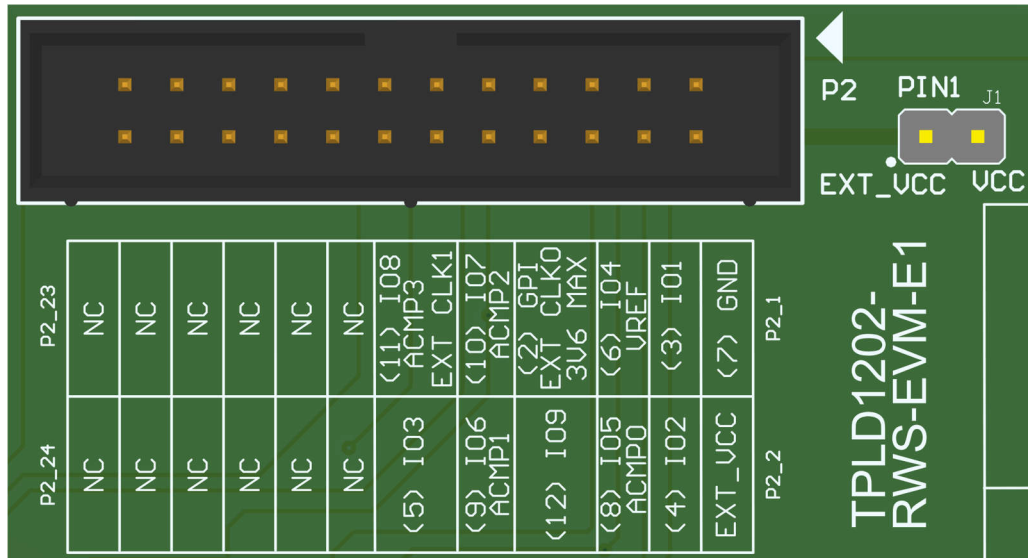

图 2-2. GPI 保护块

### 2.1.5 I2C 地址块

TPLD1202 具有可选的 I2C 地址硬件配置特性，允许通过器件启动时某些引脚的状态，来设置 TPLD1202 的 I2C 地址。该地址块包含上拉和下拉电阻器，可用于设置 TPLD1202 的 I2C 地址。要设置器件的 I2C 地址，可使用分流器将地址的每个位设置为 1 或 0。要将位设置为 1，请在地址位的中间引脚和标记为 1 的引脚之间放置一个分流器。要将位设置为 0，请在地址位的中间引脚和标记为 0 的引脚之间放置一个分流器。

表 2-2. I2C 地址块

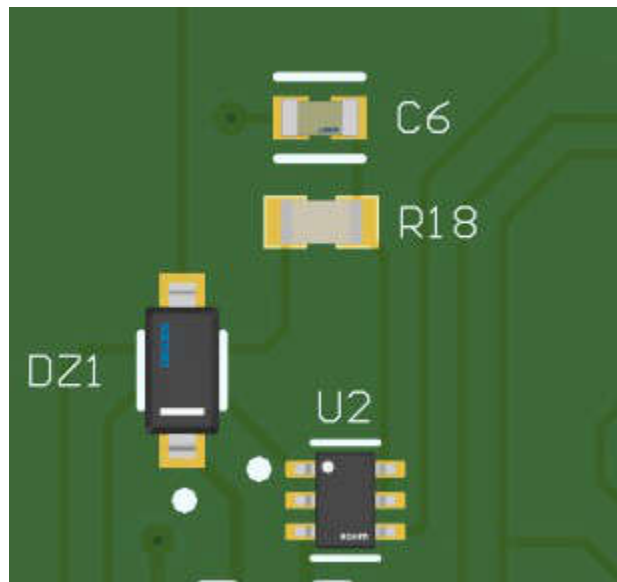
I2C 地址位	引脚编号	IO 名称
0	4	GPI
1	8	IO4
2	10	IO5

表 2-2. I2C 地址块 (续)

I2C 地址位	引脚编号	IO 名称
3	1	IO8



图 2-3. I2C 地址块

### 2.1.6 接口选择块

使用 I2C 或 SPI 对 TPLD1202 进行编程。在器件启动期间，未编程的 TPLD 会选择可通过其进行编程的 SPI 或 I2C。可根据启动期间 IO1 上的电压进行此选择。如果该电压高，则器件以 SPI 模式启动。如果该电压较低，则器件以 I2C 模式启动。器件在该引脚上有一个内部下拉电阻器，因此器件默认为 I2C 模式。

接口选择块包含一个三态开关选择，即 SPI 模式 (上拉) 或 I2C 模式 (下拉)。

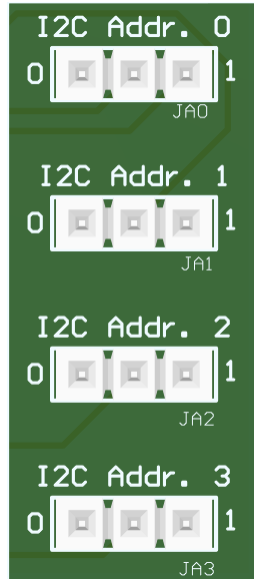
为了防止在对其地址已预先配置的 TPLD 进行编程时发生冲突，TPLD-PROGRAM 使用 SPI 与插座中的器件进行通信。这意味着接口选择块必须设置为 SPI 模式才能使用 TPLD-PROGRAM 对器件进行编程。



图 2-4. I2C 地址和接口选择块

### 2.1.7 RWS/RWB 插座

RWS/RWB 插座用于测试 TPLD 器件以及对其进行编程，而无需将器件焊接到 EVM。插座可以容纳 TPLD1202RWS 和 TPLD1202RWB 器件，而无需更改电路板。

要将器件插入插座中，请按照节 3.2 中的步骤操作。

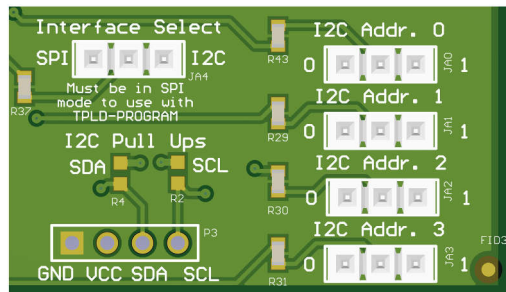
## 2.2 GPIO 测试块

该器件上的 10 个 GPIO 引脚连接到各种测试块，以进行原型设计。GPIO 测试块 指示了连接。

表 2-3. GPIO 测试块

RWS 引脚编号	RWB 引脚编号 (未印制在电路板上)	IO 名称	测试块	测试块名称
3	5	IO1	LED	LED1
4	6	IO2	LED	LED2
6	7	IO3	LED	LED3
10	12	IO7	LED	LED7
11	1	IO8	SW/LED	SW3/LED8
12	2	IO9	SW/LED	SW1/LED9
2	4	GPI	SW	SW2
6	8	IO4	LED/POT	LED4/R4
8	10	IO5	LED/POT	LED5/R5
9	11	IO6	LED/POT	LED11/R6

### 2.2.1 LED 块

每个 LED 块包含一个 LED，该 LED 可以通过接头与 TPLD 引脚连接或断开。要将 LED 连接到相应引脚，请在两个接头引脚之间的相应接头上放置一个分流器。



图 2-5. LED 块

### 2.2.2 开关/LED 块

每个 SW/LED 块均包含一个 4 位接头，该接头可连接到具有可选去抖电路的触控开关或连接到 LED。4 位接头的一侧 (标有 OFF) 直接连接到开关输出，4 位接头的另一侧 (标有 ON) 连接到一个去抖电路，然后再连接到开关输出。标有 LED 的引脚连接到 LED。接头的中间引脚连接到相应的 TPLD 引脚。要直接连接到开关输出，请在接头的中间引脚和 OFF 引脚之间放置一个分流器。要连接到去抖电路，请在接头的中间引脚和 OFF 引脚之间放置一个分流器。要连接到 LED，请在接头的中间引脚和 LED 引脚之间放置一个分流器。如果在任何一组引脚之间均未放置分流器，则 TPLD 引脚悬空。

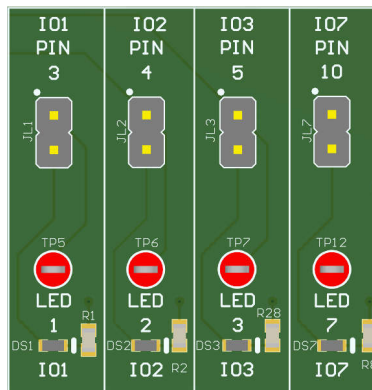

图 2-6. 开关/LED 块

### 2.2.3 开关模块

GPI 线路连接到一个触控式开关。该开关没有去抖功能。这是为了在编程期间保护 GPI 信号。

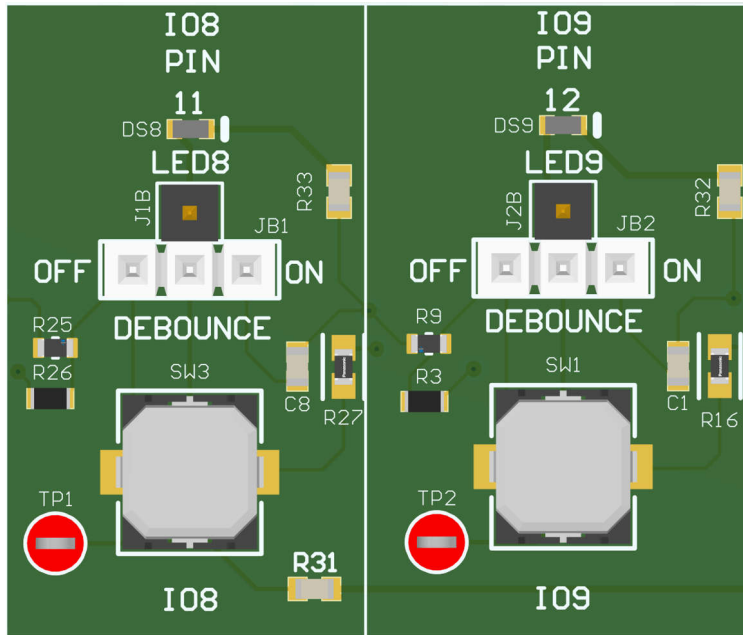

图 2-7. 开关模块

### 2.2.4 LED/电位器块

每个 LED/POT 块均包含一个三态接头引脚，用于将相应的 GPIO 引脚连接到模拟电压源或 LED。接头的中间引脚连接到 TPLD 的相应 GPIO 引脚。接头引脚的左侧 ( 标有 LED ) 连接到 LED。接头引脚的右侧 ( 标有 R ) 连接到模拟电压源。要将相应的 GPIO 连接到 LED，请在中间引脚和 LED 引脚之间放置一个分流器。要将 GPIO 连接到模拟电压源，请在中间引脚和 R 引脚之间放置一个分流器。

模拟电压源包含一个使用 POT 的分压器。当 POT 按顺时针旋转到底时，模拟电压源可输出最高 0.2V 的电压。当 POT 按逆时针方向旋转到底时，模拟电压源输出至少 VCC - 0.2V 的电压。

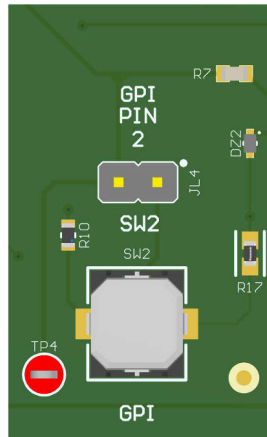

图 2-8. LED/POT 块

## 3 软件

### 3.1 使用 TPLD1202-RWS-EVM

本节介绍了如何使用 TPLD1202-RWS-EVM 对 TPLD1202 进行编程。如需获取有关使用 InterConnect Studio (ICS) 自行创建电路的更多帮助，请参阅“[InterConnect Studio 用户指南](#)”。

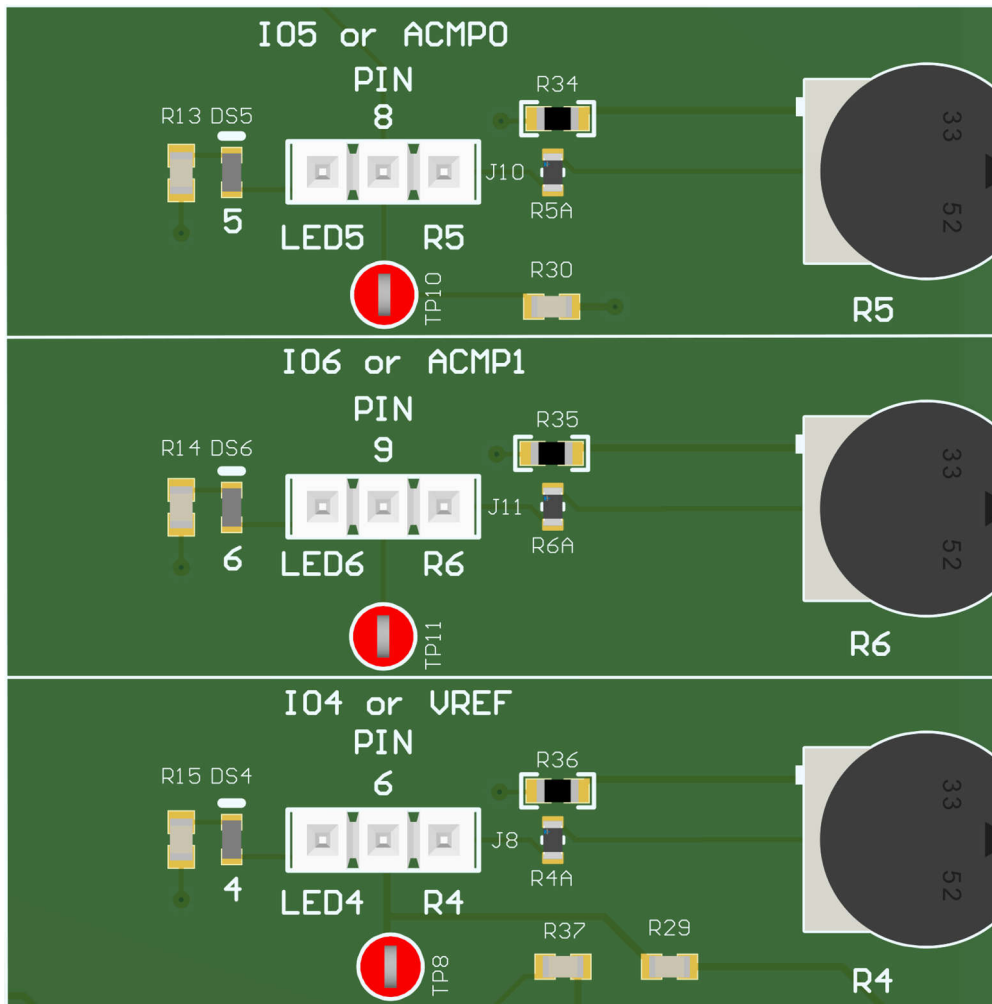
#### 3.1.1 编程所需的设备

要使用 TPLD1202-RWS-EVM 对 TPLD 器件进行编程，需要一个 TPLD-PROGRAM 套件和一台运行 InterConnect Studio 的计算机。TPLD-PROGRAM 套件包含将计算机连接到 TPLD1202-RWS-EVM 所需的一切。按照节 3.1.2 中的说明从 TI.com 下载 InterConnect Studio。

#### 备注

当 TPLD-PROGRAM 通电并连接 TPLD1202-RWS-EVM 时，如果在相关跳线上放置了分流器，则 LED1 和 LED2 会亮起。这属于正常现象，是由 TPLD-PROGRAM 上这些线路所安装的 I2C 上拉电阻所致。



图 3-1. 连接 TPLD EVM 和编程器

#### 3.1.2 安装软件

InterConnect Studio (ICS) 可从 [interconnect\\_studio.itg.ti.com](http://interconnect_studio.itg.ti.com) 免费获取

有关使用 InterConnect Studio (ICS) 的详细信息，请参阅“[InterConnect Studio 用户指南](#)”。

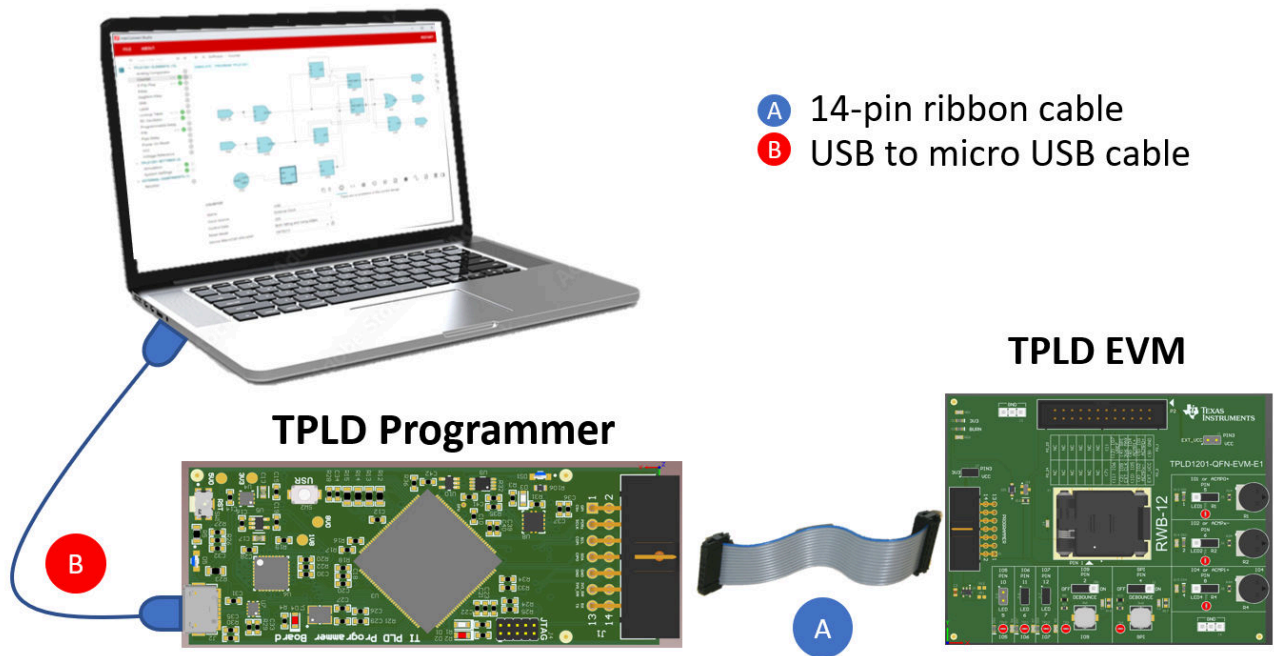
### 3.2 配置 TPLD 器件

本节介绍了使用 TPLD1202-RWS-EVM 和 TPLD-PROGRAM 套件对 TPLD1202RWS 或 TPLD1202RWB 进行编程的步骤。

#### 3.2.1 用于编程的 TPLD1202-RWS-EVM 设置

确保满足以下条件：

1. 将 SW4 置于 ON 位置
2. 删除 I2C 地址 0 跳线

3. 移除 EXT\_VCC (J1) 跳线
4. 断开 P2 与任何外部系统的连接
5. 在接口选择模块的 SPI 侧和中间引脚之间放置



图 3-2. 编程设置中考虑的元素

### 3.2.2 将 TPLD1202RWS 插入 RWS/RWB 插座

请勿在通电电路板上移除、更换或添加 TPLD 器件。请勿将手指放在插座内或触摸插座底部的触点。TI 建议在处理 TPLD1202RWS 或 TPLD1202RWB 时遵循典型的 ESD 保护程序。

1. 轻轻拉动闩锁以打开插座，直到盖板弹开。
2. 用干净的压缩空气吹净插座触点和器件焊盘，确保插座干净整洁。
3. 使用真空笔或防静电镊子将器件导入插座。将器件的引脚 1 与插座的引脚 1 对齐，如下所示。
4. 合上插座盖，直至闩锁卡入到位并将盖板固定到位。

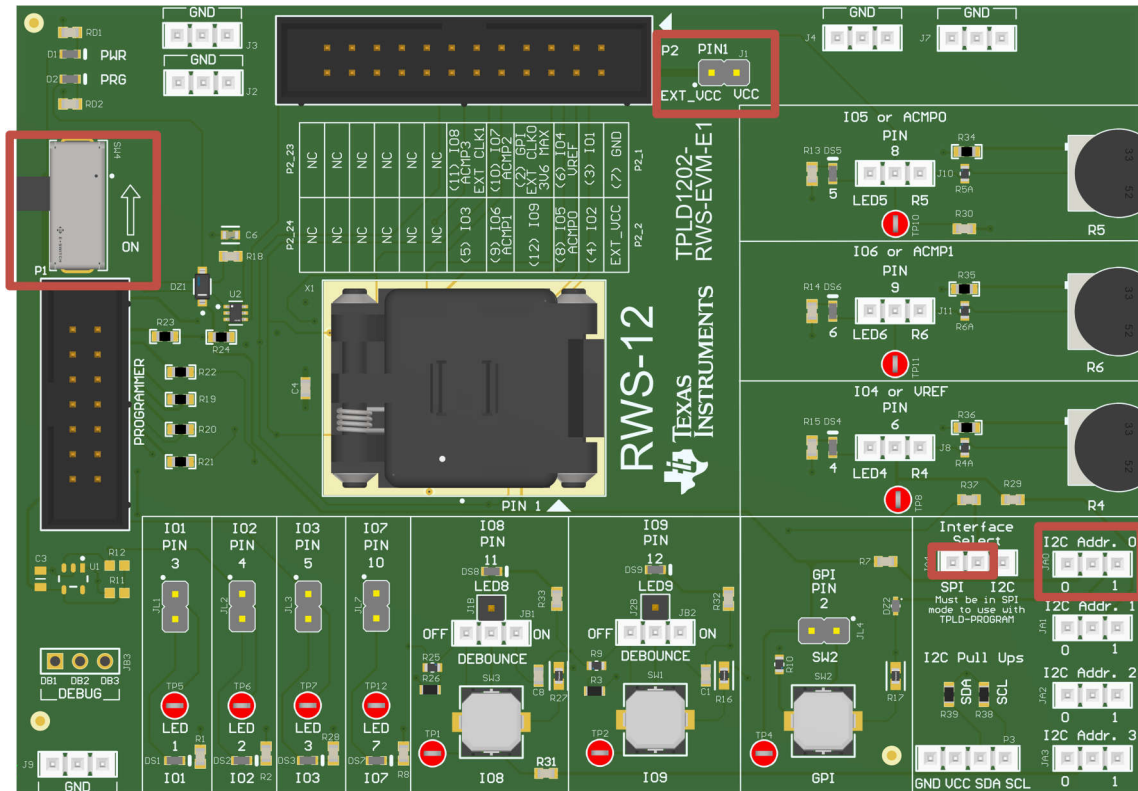

图 3-3. RWS/RWB 插座

### 3.2.3 将 TPLD1202-RWS-EVM 连接到 TPLD-PROGRAM 板

随附的所有电缆均为键控电缆，只有在朝向正确方向时才能插入。如果在轻微施力的情况下无法插入电缆，请尝试调换电缆的方向，并确保接头外壳未被阻塞，然后再次尝试。强制连接可能会导致电缆和电路板损坏。

1. 使用提供的 USB 电缆将编程器板连接到运行 InterConnect Studio 的计算机。确保 TPLD-PROGRAM 和计算机之间连接良好，即 TPLD-PROGRAM 上的两个蓝色 LED 都亮起。使用 TPLD1202-RWS-EVM 中显示了一个完全连接的 EVM 示例。
2. 使用提供的 14 位带状电缆将 TPLD-PROGRAM 与 TPLD1202-RWS-EVM 连接在一起。确保 TPLD1202-RWS-EVM 和 TPLD-PROGRAM 之间连接良好，即 EVM 左上方的 3V3 LED 指示亮起。

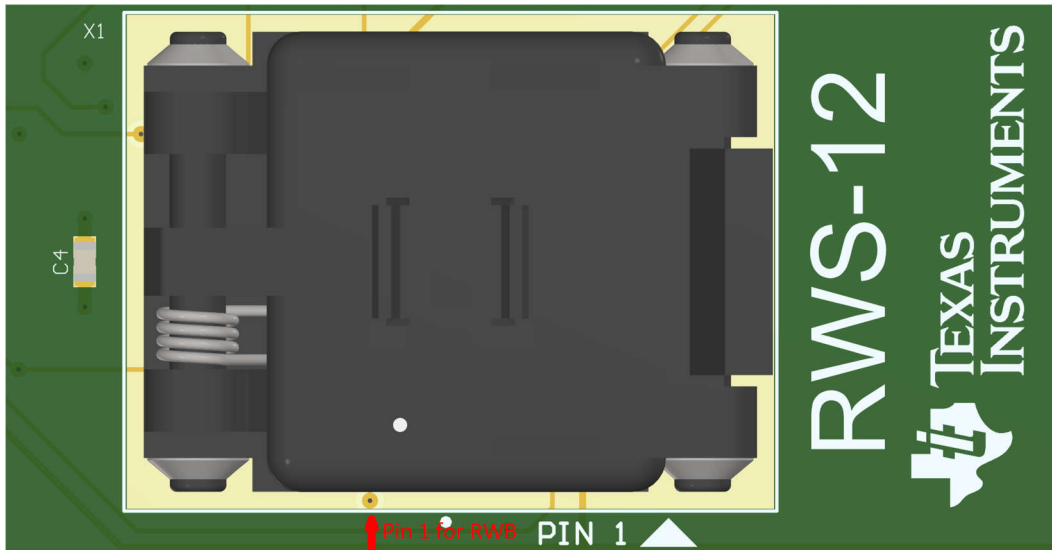
#### 备注

当 TPLD-PROGRAM 通电并连接 TPLD1202-RWS-EVM 时，如果在相关跳线上放置了分流器，则 LED1 和 LED2 会亮起。这属于正常现象，是由 TPLD-PROGRAM 上这些线路所安装的 I2C 上拉电阻所致。



图 3-4. 键控接头插座

### 3.2.4 对 TPLD 器件进行临时配置

本节介绍了如何使用 InterConnect Studio 来配置 TPLD1202。

如果对 TPLD 进行了临时配置，断开器件电源会导致 TPLD 复位并擦除配置的电路。TPLD 可以多次重新配置，而无需在两种配置之间复位。

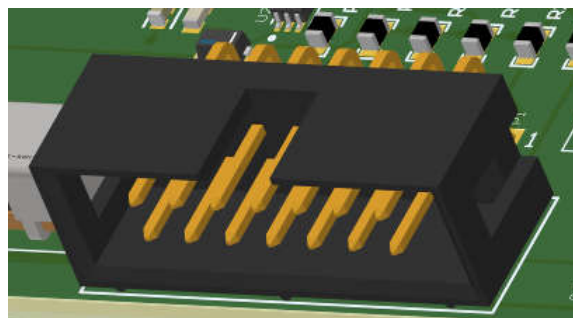
1. 在 TPLD-PROGRAM 连接到的计算机上打开 InterConnect Studio。在 *Device* 下，选择 *TPLD1202*。在 *Package* 下，选择 *RWS (X2QFN, 12)* 或 *RWB (X2QFN, 12)*。
2. 从预先设计的电路列表选择一个演示，或选择 *Empty Design* 构建定制电路。



图 3-5. 在 ICS 中选择 TPLD1202RWS 或 TPLD1202RWB

3. InterConnect Studio 会打开所选电路。
4. 选择 InterConnect Studio 左上角的 *CONFIGURE TPLD1202*，以使用 InterConnect Studio 所示的电路配置 EVM 插座中的 TPLD。选择连接到 TPLD-PROGRAM 的串行端口，然后选择 *OK*。

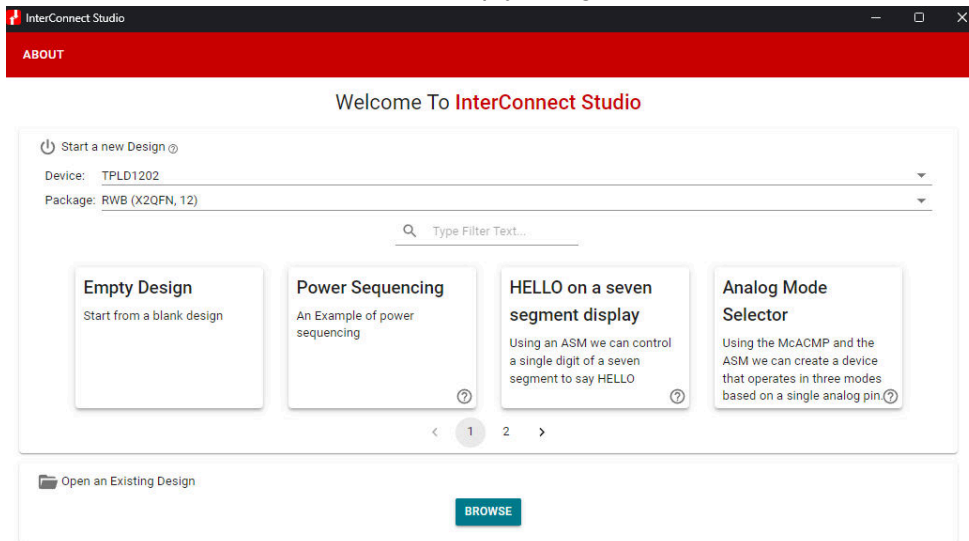

图 3-6. 在 ICS 中进行临时配置

- a. TPLD1202-RWS-EVM 上的某些 LED 会在编程序列期间闪烁，这是正常现象。
- b. 如果配置失败，请检查 EVM 和计算机之间的连接，确保 SW4 处于 ON 位置并检查 TPLD 器件和插座触点之间的连接，然后重试。

编程序列完成后，会使用 InterConnect Studio 中内置的电路临时配置电路板上的 TPLD 器件。配置的电路可以使用 EVM 上提供的按钮、电位器和 LED 进行测试。

### 3.2.5 对 TPLD 器件进行永久编程

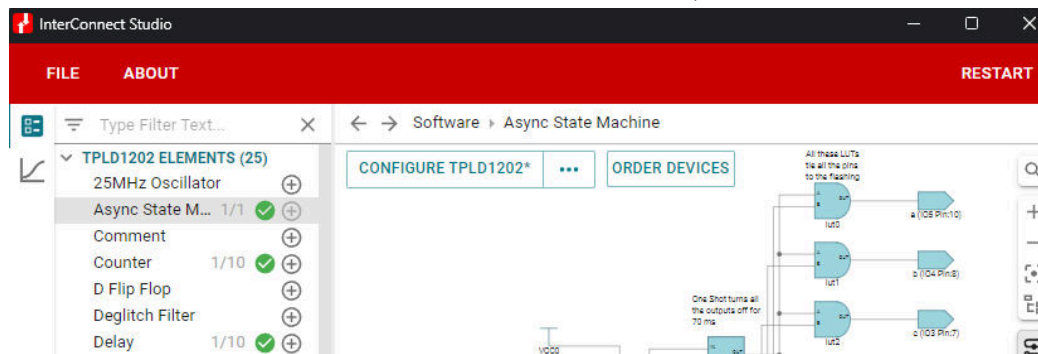
本节介绍了如何使用 InterConnect Studio 对 TPLD1202 进行永久编程。永久编程的器件会在电源复位后保留已编程的配置。

不得再次对经过永久编程的器件进行永久编程，以避免损坏器件。

1. 在 InterConnect Studio 中打开要在 TPLD1202 中永久编程的所需配置。
2. 选择 *CONFIGURE TPLD1202* 按钮旁边的三点图标，以打开“Configure Settings”。
3. 选择 *Permanently Configure Device*。如果使用 TPLD-PROGRAM 为 EVM 供电，则将“Power Source”保留为 *Programmer*。选择 *OK*。



图 3-7. 在 ICS 中进行永久编程

4. 选择连接到 TPLD-PROGRAM 的串行端口，然后再次选择 OK。
  - a. TPLD1202-RWS-EVM 上的某些 LED 可能会在编程序列期间闪烁，这是正常现象。
  - b. 如果配置失败，请检查 EVM 和计算机之间的连接，确保 SW4 处于 ON 位置并检查 TPLD 器件和插座触点之间的连接，然后重试。
5. 在移除永久编程的 TPLD1202 之前，请先断开 EVM 的电源。

### 3.3 使用 TPLD1202-RWS-EVM 对 TPLD1202RWB 或 TPLD1202RWS 进行编程

TPLD1202-RWS-EVM 无需对电路板进行任何更改，即可对 TPLD1202RWS 和 TPLD1202RWB 进行编程。要对 TPLD1202RWB 进行编程，请按照节 3.2.2 中的说明将 TPLD1202RWB 器件插入 RWS/RWB 插座。使用 TPLD1202-RWS-EVM，选择 TPLD1202RWB 设计和 ICS 并正常配置，如节 3.2 所述。

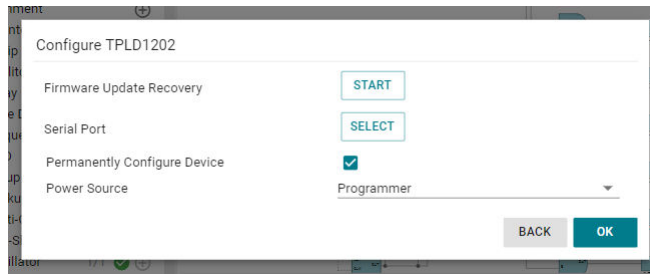

图 3-8. RWS/RWB 插座

评估 TPLD1202RWB 或 TPLD1202RWS 器件时，EVM 上印制的 IO 映射正确，但引脚编号会映射到器件的错误引脚，因为映射对应于 TPLD1202RWB 或 TPLD1202RWS 的引脚。使用此图表，通过电路板上的标识来确定 RWB 器件的正确引脚编号。

引脚名称	RWS 引脚编号	RWB 引脚编号
IO1	3	5
IO2	4	6
IO3	5	7
IO4	6	8
IO5	8	10
IO6	9	11

引脚名称	RWS 引脚编号	RWB 引脚编号
IO7	10	12
IO8	11	1
IO9	12	2
GPI	2	4
VCC	1	3
GND	7	9

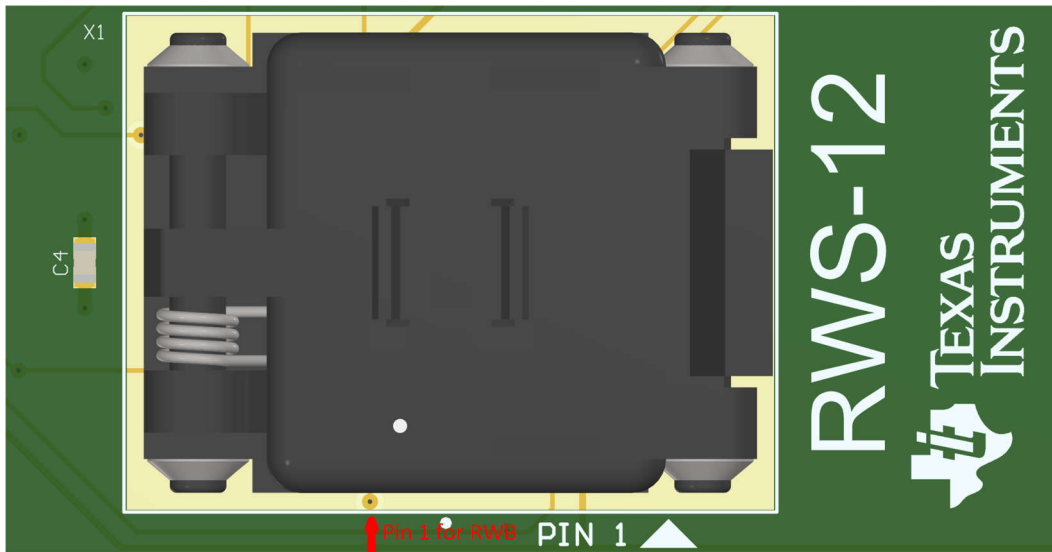
## 4 硬件设计文件

### 4.1 原理图



图 4-1. TPLD1202-RWS-EVM 原理图 1

## Switches / LEDs



## I2C Address Selector

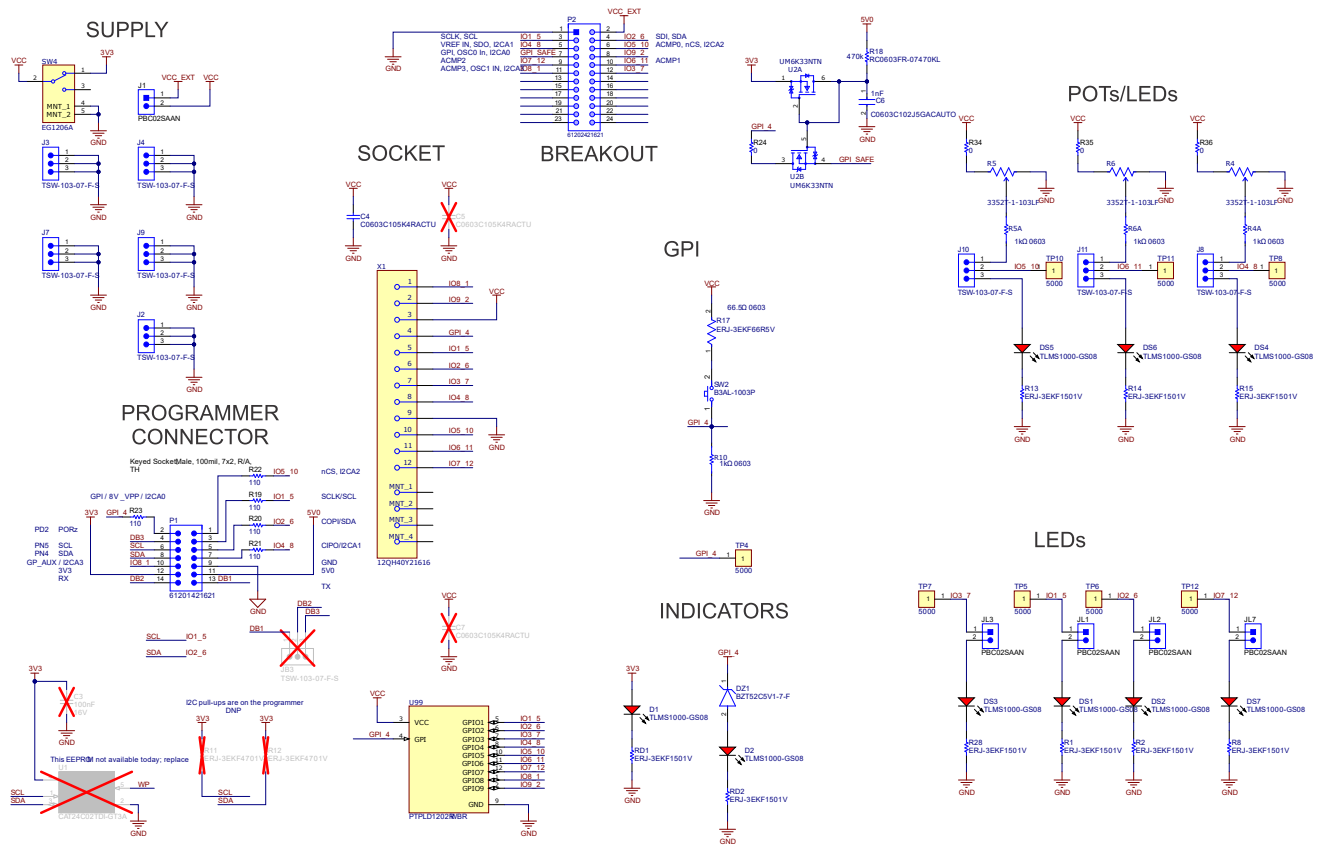
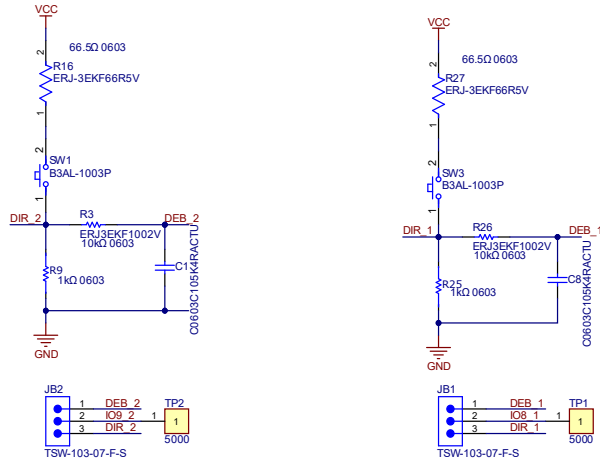

图 4-2. TPLD1202-RWS-EVM 原理图 2

## 4.2 PCB 布局

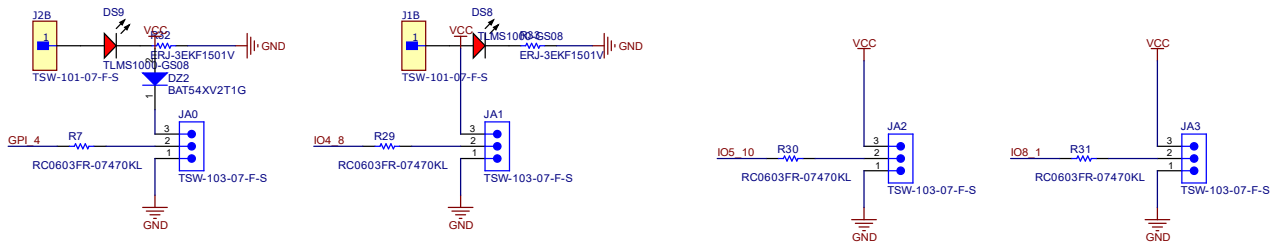

图 4-3. TPLD1202-RWS-EVM 布局

### 4.2.1 PCB 概述



图 4-4. TPLD1202-RWS-EVM 电路板正面

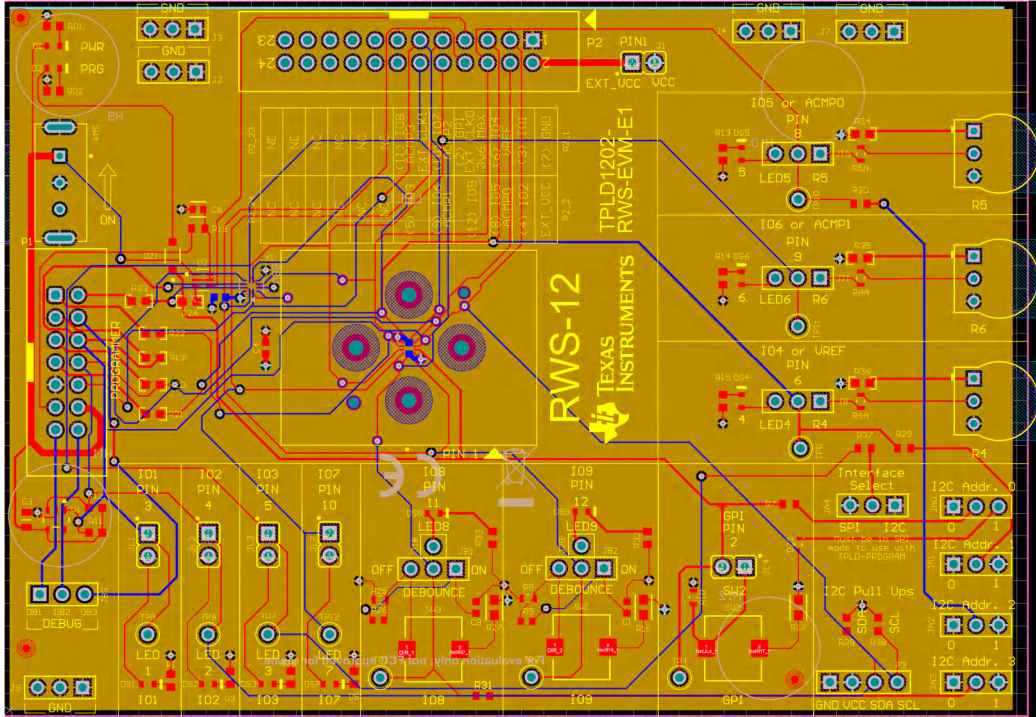

图 4-5. TPLD1202-RWS-EVM 电路板底层

### 4.3 物料清单

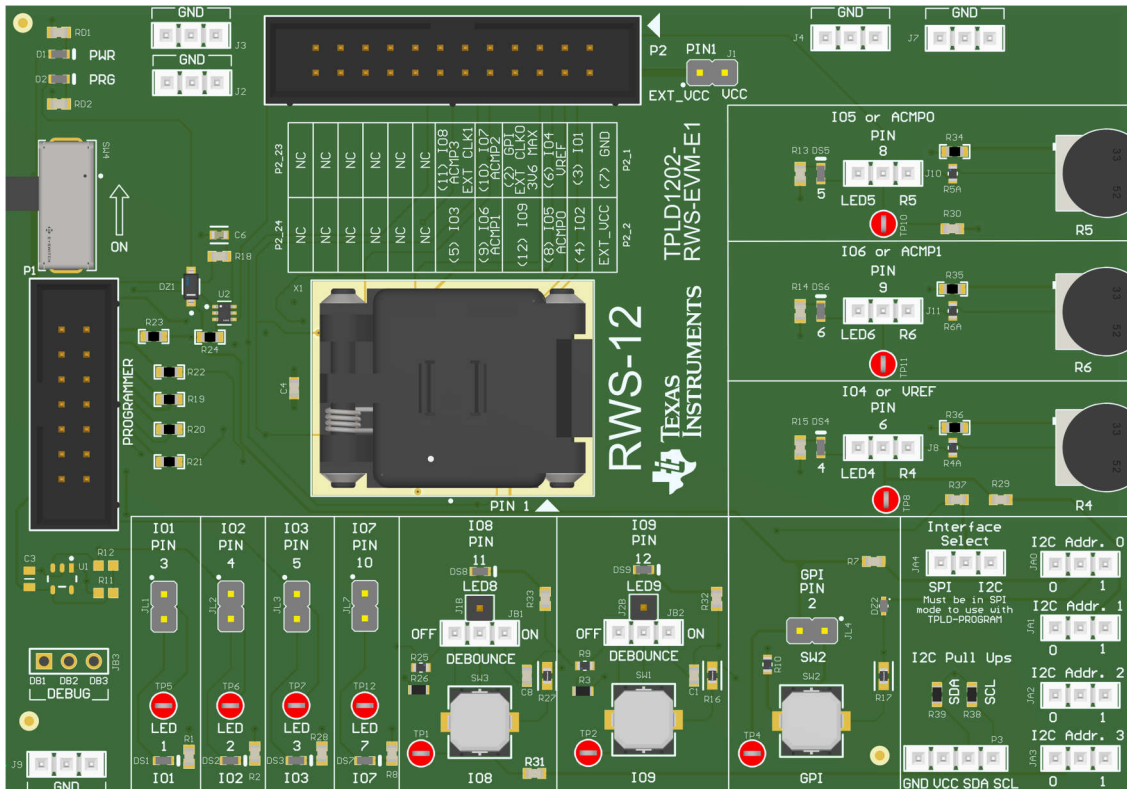
本节提供了有关可与 TPLD1202-RWS-EVM 一同使用的元件的信息。可以使用其他元件，只要这些元件适合提供的电镀孔和焊盘即可。

**表 4-1. TPLD1202-RWS-EVM 物料清单**

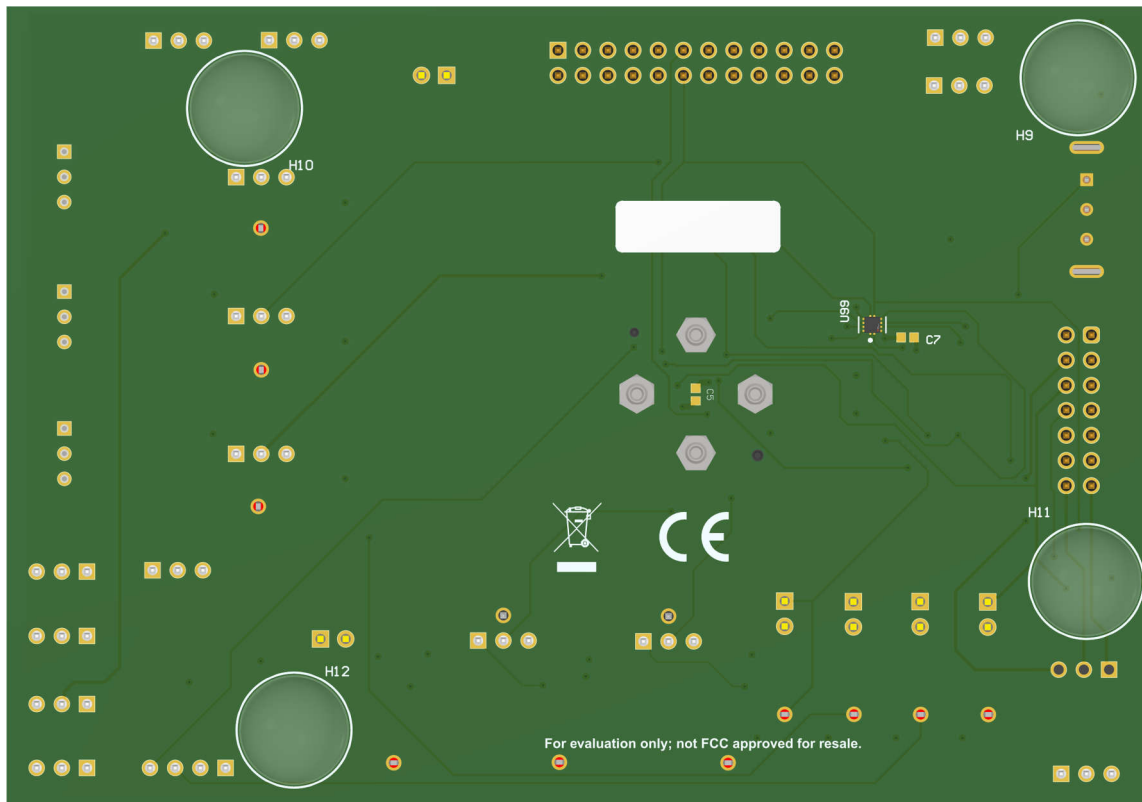
位号	条目	值	制造商	器件型号
C1、C4、C8	电容器	1 $\mu$ F	Yageo	C0603C105K4RACTU
C5、C7	电容器	DNP	Knowles Syfer	060330160104JXT
C6	电容器	1000pF	KEMET	C0603C102J5GACAUTO
D1、D2、DS1、DS2、DS4、DS6、DS7、DS8	LED	红色	Vishay	TLMS1000-GS08
DZ1	二极管	5.1V	二极管	BZT52C5V1-7F
DZ2	二极管	800mV	ON Semiconductor	BAT54XV2T1G
H9、H10、H11、H12	Bumpon	清除	3M	SJ-5303 (CLEAR)
J1、JL1、JL2、JL3、JL7	接头	2x1	Sullins	PBC02SAAN
J1B、J2B	接头	1x1	Samtec	TSW-101-07F-S
J2、J3、J4、J7、J8、J9、J10、J11、JA0、JA1、JA2、JA3、JB1、JB2	接头	3x1	Samtec	TSW-103-07F-S
P1	接头	7x2	Würth Electronics	61201421721
P2	接头	12x2	Würth Electronics	61202421621
R4、R5、R6	电阻器	10k $\Omega$	Bourns	3352T-1-103LF
R4A、R5A、R6A、R9、R10、R25	电阻器	1k $\Omega$	Vishay	CRCW06031K00FKEAC
R3、R26	电阻器	10k $\Omega$	Vishay Dale	CRCW060310K0FKEC
R1、R2、R8、R13、R14、R15、R28、R32、R33、RD1、RD2	电阻器	1.5k $\Omega$	Panasonic	ERJ-3EKF1501V
R11、R12	电阻器	DNP	Yageo	ERJ-3EKF4701V
R16、R17、R27	电阻器	66.5 $\Omega$	Panasonic	ERJ-3EKF66R5V
R7、R18、R29、R30、R31	电阻器	470k $\Omega$	Yageo	RC0603FR-07470KL
R24、R34、R35、R36	电阻器	0 $\Omega$	Stackpole Electronics Inc	RMCF0603ZT0R00
R19、R20、R21、R22、R23	电阻器	110 $\Omega$	Vishay Dale	CRCW0603110RJNEA
SH-J1、SH-J2、SH-J3、SH-J4、SH-J5、SH-J6、SH-J7、SH-J8、SH-J9、SH-J10、SH-J11、SH-J12、SH-J13	分流器		Sullins Connector Solutions	SPC02SYAN
SW4	开关	滑动	E-Switch	EG1206A
SW1、SW2、SW3	开关	触控式	欧姆龙 (Omron)	B3AL-1003P
TP1、TP2、TP4、TP5、TP6、TP7、TP8、TP10、TP11、TP12	测试点	红色	Keystone Electronics	5000
U1	EEPROM	DNP	Microchip/Atmel	CAT24C02TDI-GT3A
U2	晶体管		Rohm	UM6K33NTN

表 4-1. TPLD1202-RWS-EVM 物料清单 (续)

位号	条目	值	制造商	器件型号
X1	插座	RWB	Plastronics	12QH40Y21616
U99	TPLD	DNP	德州仪器 (TI)	TPLD1202RWSR

## 5 其他信息

### 5.1 商标

所有商标均为其各自所有者的财产。

## 6 参考资料

1. 德州仪器 (TI) , [CMOS 输入缓慢或悬空的影响 应用手册](#)

## 7 修订历史记录

注：以前版本的页码可能与当前版本的页码不同

<b>Changes from Revision A (December 2025) to Revision B (June 2026)</b>	<b>Page</b>
• 将 EVM 器件从 TPLD1202-RWB-EVM 更新到 TPLD1202-RWS-EVM.....	1
• 通篇添加了 TPLD1202RWB.....	1
• 将器件信息段落移至简介.....	1
• 添加了标题到 <a href="#">表 2-1</a> .....	3
• 添加了标题到 <a href="#">表 2-2</a> .....	4
• 添加了标题到 <a href="#">表 2-3</a> .....	5
• 已使用 TPLD1202-RWS-EVM 将 TPLD1202RWB 或 TPLD1202RWS 编程到软件中.....	13

<b>Changes from Revision * (August 2024) to Revision A (December 2025)</b>	<b>Page</b>
• 更新了硬件图像.....	1

## STANDARD TERMS FOR EVALUATION MODULES

1. *Delivery:* TI delivers TI evaluation boards, kits, or modules, including any accompanying demonstration software, components, and/or documentation which may be provided together or separately (collectively, an "EVM" or "EVMs") to the User ("User") in accordance with the terms set forth herein. User's acceptance of the EVM is expressly subject to the following terms.
  - 1.1 EVMs are intended solely for product or software developers for use in a research and development setting to facilitate feasibility evaluation, experimentation, or scientific analysis of TI semiconductors products. EVMs have no direct function and are not finished products. EVMs shall not be directly or indirectly assembled as a part or subassembly in any finished product. For clarification, any software or software tools provided with the EVM ("Software") shall not be subject to the terms and conditions set forth herein but rather shall be subject to the applicable terms that accompany such Software
  - 1.2 EVMs are not intended for consumer or household use. EVMs may not be sold, sublicensed, leased, rented, loaned, assigned, or otherwise distributed for commercial purposes by Users, in whole or in part, or used in any finished product or production system.
2. *Limited Warranty and Related Remedies/Disclaimers:*
  - 2.1 These terms do not apply to Software. The warranty, if any, for Software is covered in the applicable Software License Agreement.
  - 2.2 TI warrants that the TI EVM will conform to TI's published specifications for ninety (90) days after the date TI delivers such EVM to User. Notwithstanding the foregoing, TI shall not be liable for a nonconforming EVM if (a) the nonconformity was caused by neglect, misuse or mistreatment by an entity other than TI, including improper installation or testing, or for any EVMs that have been altered or modified in any way by an entity other than TI, (b) the nonconformity resulted from User's design, specifications or instructions for such EVMs or improper system design, or (c) User has not paid on time. Testing and other quality control techniques are used to the extent TI deems necessary. TI does not test all parameters of each EVM. User's claims against TI under this Section 2 are void if User fails to notify TI of any apparent defects in the EVMs within ten (10) business days after delivery, or of any hidden defects with ten (10) business days after the defect has been detected.
  - 2.3 TI's sole liability shall be at its option to repair or replace EVMs that fail to conform to the warranty set forth above, or credit User's account for such EVM. TI's liability under this warranty shall be limited to EVMs that are returned during the warranty period to the address designated by TI and that are determined by TI not to conform to such warranty. If TI elects to repair or replace such EVM, TI shall have a reasonable time to repair such EVM or provide replacements. Repaired EVMs shall be warranted for the remainder of the original warranty period. Replaced EVMs shall be warranted for a new full ninety (90) day warranty period.

### **WARNING**

**Evaluation Kits are intended solely for use by technically qualified, professional electronics experts who are familiar with the dangers and application risks associated with handling electrical mechanical components, systems, and subsystems.**

**User shall operate the Evaluation Kit within TI's recommended guidelines and any applicable legal or environmental requirements as well as reasonable and customary safeguards. Failure to set up and/or operate the Evaluation Kit within TI's recommended guidelines may result in personal injury or death or property damage. Proper set up entails following TI's instructions for electrical ratings of interface circuits such as input, output and electrical loads.**

**NOTE:**

**EXPOSURE TO ELECTROSTATIC DISCHARGE (ESD) MAY CAUSE DEGRADATION OR FAILURE OF THE EVALUATION KIT; TI RECOMMENDS STORAGE OF THE EVALUATION KIT IN A PROTECTIVE ESD BAG.**

### 3 Regulatory Notices:

#### 3.1 United States

##### 3.1.1 Notice applicable to EVMs not FCC-Approved:

**FCC NOTICE:** This kit is designed to allow product developers to evaluate electronic components, circuitry, or software associated with the kit to determine whether to incorporate such items in a finished product and software developers to write software applications for use with the end product. This kit is not a finished product and when assembled may not be resold or otherwise marketed unless all required FCC equipment authorizations are first obtained. Operation is subject to the condition that this product not cause harmful interference to licensed radio stations and that this product accept harmful interference. Unless the assembled kit is designed to operate under part 15, part 18 or part 95 of this chapter, the operator of the kit must operate under the authority of an FCC license holder or must secure an experimental authorization under part 5 of this chapter.

##### 3.1.2 For EVMs annotated as FCC – FEDERAL COMMUNICATIONS COMMISSION Part 15 Compliant:

#### **CAUTION**

This device complies with part 15 of the FCC Rules. Operation is subject to the following two conditions: (1) This device may not cause harmful interference, and (2) this device must accept any interference received, including interference that may cause undesired operation.

Changes or modifications not expressly approved by the party responsible for compliance could void the user's authority to operate the equipment.

#### **FCC Interference Statement for Class A EVM devices**

*NOTE: This equipment has been tested and found to comply with the limits for a Class A digital device, pursuant to part 15 of the FCC Rules. These limits are designed to provide reasonable protection against harmful interference when the equipment is operated in a commercial environment. This equipment generates, uses, and can radiate radio frequency energy and, if not installed and used in accordance with the instruction manual, may cause harmful interference to radio communications. Operation of this equipment in a residential area is likely to cause harmful interference in which case the user will be required to correct the interference at his own expense.*

#### **FCC Interference Statement for Class B EVM devices**

*NOTE: This equipment has been tested and found to comply with the limits for a Class B digital device, pursuant to part 15 of the FCC Rules. These limits are designed to provide reasonable protection against harmful interference in a residential installation. This equipment generates, uses and can radiate radio frequency energy and, if not installed and used in accordance with the instructions, may cause harmful interference to radio communications. However, there is no guarantee that interference will not occur in a particular installation. If this equipment does cause harmful interference to radio or television reception, which can be determined by turning the equipment off and on, the user is encouraged to try to correct the interference by one or more of the following measures:*

- Reorient or relocate the receiving antenna.
- Increase the separation between the equipment and receiver.
- Connect the equipment into an outlet on a circuit different from that to which the receiver is connected.
- Consult the dealer or an experienced radio/TV technician for help.

#### 3.2 Canada

##### 3.2.1 For EVMs issued with an Industry Canada Certificate of Conformance to RSS-210 or RSS-247

#### **Concerning EVMs Including Radio Transmitters:**

This device complies with Industry Canada license-exempt RSSs. Operation is subject to the following two conditions:

(1) this device may not cause interference, and (2) this device must accept any interference, including interference that may cause undesired operation of the device.

#### **Concernant les EVMs avec appareils radio:**

Le présent appareil est conforme aux CNR d'Industrie Canada applicables aux appareils radio exempts de licence. L'exploitation est autorisée aux deux conditions suivantes: (1) l'appareil ne doit pas produire de brouillage, et (2) l'utilisateur de l'appareil doit accepter tout brouillage radioélectrique subi, même si le brouillage est susceptible d'en compromettre le fonctionnement.

#### **Concerning EVMs Including Detachable Antennas:**

Under Industry Canada regulations, this radio transmitter may only operate using an antenna of a type and maximum (or lesser) gain approved for the transmitter by Industry Canada. To reduce potential radio interference to other users, the antenna type and its gain should be so chosen that the equivalent isotropically radiated power (e.i.r.p.) is not more than that necessary for successful communication. This radio transmitter has been approved by Industry Canada to operate with the antenna types listed in the user guide with the maximum permissible gain and required antenna impedance for each antenna type indicated. Antenna types not included in this list, having a gain greater than the maximum gain indicated for that type, are strictly prohibited for use with this device.

### Concernant les EVMs avec antennes détachables

Conformément à la réglementation d'Industrie Canada, le présent émetteur radio peut fonctionner avec une antenne d'un type et d'un gain maximal (ou inférieur) approuvé pour l'émetteur par Industrie Canada. Dans le but de réduire les risques de brouillage radioélectrique à l'intention des autres utilisateurs, il faut choisir le type d'antenne et son gain de sorte que la puissance isotrope rayonnée équivalente (p.i.r.e.) ne dépasse pas l'intensité nécessaire à l'établissement d'une communication satisfaisante. Le présent émetteur radio a été approuvé par Industrie Canada pour fonctionner avec les types d'antenne énumérés dans le manuel d'usage et ayant un gain admissible maximal et l'impédance requise pour chaque type d'antenne. Les types d'antenne non inclus dans cette liste, ou dont le gain est supérieur au gain maximal indiqué, sont strictement interdits pour l'exploitation de l'émetteur.

#### 3.3 Japan

3.3.1 *Notice for EVMs delivered in Japan:* Please see [http://www.tij.co.jp/lstds/ti\\_ja/general/eStore/notice\\_01.page](http://www.tij.co.jp/lstds/ti_ja/general/eStore/notice_01.page) 日本国内に輸入される評価用キット、ボードについては、次のところをご覧ください。

<https://www.ti.com/ja-jp/legal/notice-for-evaluation-kits-delivered-in-japan.html>

3.3.2 *Notice for Users of EVMs Considered "Radio Frequency Products" in Japan:* EVMs entering Japan may not be certified by TI as conforming to Technical Regulations of Radio Law of Japan.

If User uses EVMs in Japan, not certified to Technical Regulations of Radio Law of Japan, User is required to follow the instructions set forth by Radio Law of Japan, which includes, but is not limited to, the instructions below with respect to EVMs (which for the avoidance of doubt are stated strictly for convenience and should be verified by User):

1. Use EVMs in a shielded room or any other test facility as defined in the notification #173 issued by Ministry of Internal Affairs and Communications on March 28, 2006, based on Sub-section 1.1 of Article 6 of the Ministry's Rule for Enforcement of Radio Law of Japan,
2. Use EVMs only after User obtains the license of Test Radio Station as provided in Radio Law of Japan with respect to EVMs, or
3. Use of EVMs only after User obtains the Technical Regulations Conformity Certification as provided in Radio Law of Japan with respect to EVMs. Also, do not transfer EVMs, unless User gives the same notice above to the transferee. Please note that if User does not follow the instructions above, User will be subject to penalties of Radio Law of Japan.

【無線電波を送信する製品の開発キットをお使いになる際の注意事項】 開発キットの中には技術基準適合証明を受けていないものがあります。技術適合証明を受けていないものご使用に際しては、電波法遵守のため、以下のいずれかの措置を取っていただく必要がありますのでご注意ください。

1. 電波法施行規則第6条第1項第1号に基づく平成18年3月28日総務省告示第173号で定められた電波暗室等の試験設備でご使用いただく。
2. 実験局の免許を取得後ご使用いただく。
3. 技術基準適合証明を取得後ご使用いただく。

なお、本製品は、上記の「ご使用にあたっての注意」を譲渡先、移転先に通知しない限り、譲渡、移転できないものとします。

上記を遵守頂けない場合は、電波法の罰則が適用される可能性があることをご留意ください。日本テキサス・イ

ンスツルメンツ株式会社

東京都新宿区西新宿 6 丁目 2 4 番 1 号

西新宿三井ビル

3.3.3 *Notice for EVMs for Power Line Communication:* Please see [http://www.tij.co.jp/lstds/ti\\_ja/general/eStore/notice\\_02.page](http://www.tij.co.jp/lstds/ti_ja/general/eStore/notice_02.page)

電力線搬送波通信についての開発キットをお使いになる際の注意事項については、次のところをご覧ください。 <https://www.ti.com/ja-jp/legal/notice-for-evaluation-kits-for-power-line-communication.html>

#### 3.4 European Union

3.4.1 *For EVMs subject to EU Directive 2014/30/EU (Electromagnetic Compatibility Directive):*

This is a class A product intended for use in environments other than domestic environments that are connected to a low-voltage power-supply network that supplies buildings used for domestic purposes. In a domestic environment this product may cause radio interference in which case the user may be required to take adequate measures.

- 
4. *EVM Use Restrictions and Warnings:*
    - 4.1 EVMS ARE NOT FOR USE IN FUNCTIONAL SAFETY AND/OR SAFETY CRITICAL EVALUATIONS, INCLUDING BUT NOT LIMITED TO EVALUATIONS OF LIFE SUPPORT APPLICATIONS.
    - 4.2 User must read and apply the user guide and other available documentation provided by TI regarding the EVM prior to handling or using the EVM, including without limitation any warning or restriction notices. The notices contain important safety information related to, for example, temperatures and voltages.
    - 4.3 *Safety-Related Warnings and Restrictions:*
      - 4.3.1 User shall operate the EVM within TI's recommended specifications and environmental considerations stated in the user guide, other available documentation provided by TI, and any other applicable requirements and employ reasonable and customary safeguards. Exceeding the specified performance ratings and specifications (including but not limited to input and output voltage, current, power, and environmental ranges) for the EVM may cause personal injury or death, or property damage. If there are questions concerning performance ratings and specifications, User should contact a TI field representative prior to connecting interface electronics including input power and intended loads. Any loads applied outside of the specified output range may also result in unintended and/or inaccurate operation and/or possible permanent damage to the EVM and/or interface electronics. Please consult the EVM user guide prior to connecting any load to the EVM output. If there is uncertainty as to the load specification, please contact a TI field representative. During normal operation, even with the inputs and outputs kept within the specified allowable ranges, some circuit components may have elevated case temperatures. These components include but are not limited to linear regulators, switching transistors, pass transistors, current sense resistors, and heat sinks, which can be identified using the information in the associated documentation. When working with the EVM, please be aware that the EVM may become very warm.
      - 4.3.2 EVMs are intended solely for use by technically qualified, professional electronics experts who are familiar with the dangers and application risks associated with handling electrical mechanical components, systems, and subsystems. User assumes all responsibility and liability for proper and safe handling and use of the EVM by User or its employees, affiliates, contractors or designees. User assumes all responsibility and liability to ensure that any interfaces (electronic and/or mechanical) between the EVM and any human body are designed with suitable isolation and means to safely limit accessible leakage currents to minimize the risk of electrical shock hazard. User assumes all responsibility and liability for any improper or unsafe handling or use of the EVM by User or its employees, affiliates, contractors or designees.
    - 4.4 User assumes all responsibility and liability to determine whether the EVM is subject to any applicable international, federal, state, or local laws and regulations related to User's handling and use of the EVM and, if applicable, User assumes all responsibility and liability for compliance in all respects with such laws and regulations. User assumes all responsibility and liability for proper disposal and recycling of the EVM consistent with all applicable international, federal, state, and local requirements.
  5. *Accuracy of Information:* To the extent TI provides information on the availability and function of EVMs, TI attempts to be as accurate as possible. However, TI does not warrant the accuracy of EVM descriptions, EVM availability or other information on its websites as accurate, complete, reliable, current, or error-free.
  6. *Disclaimers:*
    - 6.1 EXCEPT AS SET FORTH ABOVE, EVMS AND ANY MATERIALS PROVIDED WITH THE EVM (INCLUDING, BUT NOT LIMITED TO, REFERENCE DESIGNS AND THE DESIGN OF THE EVM ITSELF) ARE PROVIDED "AS IS" AND "WITH ALL FAULTS." TI DISCLAIMS ALL OTHER WARRANTIES, EXPRESS OR IMPLIED, REGARDING SUCH ITEMS, INCLUDING BUT NOT LIMITED TO ANY EPIDEMIC FAILURE WARRANTY OR IMPLIED WARRANTIES OF MERCHANTABILITY OR FITNESS FOR A PARTICULAR PURPOSE OR NON-INFRINGEMENT OF ANY THIRD PARTY PATENTS, COPYRIGHTS, TRADE SECRETS OR OTHER INTELLECTUAL PROPERTY RIGHTS.
    - 6.2 EXCEPT FOR THE LIMITED RIGHT TO USE THE EVM SET FORTH HEREIN, NOTHING IN THESE TERMS SHALL BE CONSTRUED AS GRANTING OR CONFERRING ANY RIGHTS BY LICENSE, PATENT, OR ANY OTHER INDUSTRIAL OR INTELLECTUAL PROPERTY RIGHT OF TI, ITS SUPPLIERS/LICENSORS OR ANY OTHER THIRD PARTY, TO USE THE EVM IN ANY FINISHED END-USER OR READY-TO-USE FINAL PRODUCT, OR FOR ANY INVENTION, DISCOVERY OR IMPROVEMENT, REGARDLESS OF WHEN MADE, CONCEIVED OR ACQUIRED.
  7. *USER'S INDEMNITY OBLIGATIONS AND REPRESENTATIONS.* USER WILL DEFEND, INDEMNIFY AND HOLD TI, ITS LICENSORS AND THEIR REPRESENTATIVES HARMLESS FROM AND AGAINST ANY AND ALL CLAIMS, DAMAGES, LOSSES, EXPENSES, COSTS AND LIABILITIES (COLLECTIVELY, "CLAIMS") ARISING OUT OF OR IN CONNECTION WITH ANY HANDLING OR USE OF THE EVM THAT IS NOT IN ACCORDANCE WITH THESE TERMS. THIS OBLIGATION SHALL APPLY WHETHER CLAIMS ARISE UNDER STATUTE, REGULATION, OR THE LAW OF TORT, CONTRACT OR ANY OTHER LEGAL THEORY, AND EVEN IF THE EVM FAILS TO PERFORM AS DESCRIBED OR EXPECTED.
-

8. *Limitations on Damages and Liability:*

8.1 *General Limitations.* IN NO EVENT SHALL TI BE LIABLE FOR ANY SPECIAL, COLLATERAL, INDIRECT, PUNITIVE, INCIDENTAL, CONSEQUENTIAL, OR EXEMPLARY DAMAGES IN CONNECTION WITH OR ARISING OUT OF THESE TERMS OR THE USE OF THE EVMS , REGARDLESS OF WHETHER TI HAS BEEN ADVISED OF THE POSSIBILITY OF SUCH DAMAGES. EXCLUDED DAMAGES INCLUDE, BUT ARE NOT LIMITED TO, COST OF REMOVAL OR REINSTALLATION, ANCILLARY COSTS TO THE PROCUREMENT OF SUBSTITUTE GOODS OR SERVICES, RETESTING, OUTSIDE COMPUTER TIME, LABOR COSTS, LOSS OF GOODWILL, LOSS OF PROFITS, LOSS OF SAVINGS, LOSS OF USE, LOSS OF DATA, OR BUSINESS INTERRUPTION. NO CLAIM, SUIT OR ACTION SHALL BE BROUGHT AGAINST TI MORE THAN TWELVE (12) MONTHS AFTER THE EVENT THAT GAVE RISE TO THE CAUSE OF ACTION HAS OCCURRED.

8.2 *Specific Limitations.* IN NO EVENT SHALL TI'S AGGREGATE LIABILITY FROM ANY USE OF AN EVM PROVIDED HEREUNDER, INCLUDING FROM ANY WARRANTY, INDEMNITY OR OTHER OBLIGATION ARISING OUT OF OR IN CONNECTION WITH THESE TERMS, , EXCEED THE TOTAL AMOUNT PAID TO TI BY USER FOR THE PARTICULAR EVM(S) AT ISSUE DURING THE PRIOR TWELVE (12) MONTHS WITH RESPECT TO WHICH LOSSES OR DAMAGES ARE CLAIMED. THE EXISTENCE OF MORE THAN ONE CLAIM SHALL NOT ENLARGE OR EXTEND THIS LIMIT.

9. *Return Policy.* Except as otherwise provided, TI does not offer any refunds, returns, or exchanges. Furthermore, no return of EVM(s) will be accepted if the package has been opened and no return of the EVM(s) will be accepted if they are damaged or otherwise not in a resalable condition. If User feels it has been incorrectly charged for the EVM(s) it ordered or that delivery violates the applicable order, User should contact TI. All refunds will be made in full within thirty (30) working days from the return of the components(s), excluding any postage or packaging costs.

10. *Governing Law:* These terms and conditions shall be governed by and interpreted in accordance with the laws of the State of Texas, without reference to conflict-of-laws principles. User agrees that non-exclusive jurisdiction for any dispute arising out of or relating to these terms and conditions lies within courts located in the State of Texas and consents to venue in Dallas County, Texas. Notwithstanding the foregoing, any judgment may be enforced in any United States or foreign court, and TI may seek injunctive relief in any United States or foreign court.

Mailing Address: Texas Instruments, Post Office Box 655303, Dallas, Texas 75265  
Copyright © 2023, Texas Instruments Incorporated

## 重要通知和免责声明

TI“按原样”提供技术和可靠性数据（包括数据表）、设计资源（包括参考设计）、应用或其他设计建议、网络工具、安全信息和其他资源，不保证没有瑕疵且不做任何明示或暗示的担保，包括但不限于对适销性、与某特定用途的适用性或不侵犯任何第三方知识产权的暗示担保。

这些资源可供使用 TI 产品进行设计的熟练开发人员使用。您将自行承担以下全部责任：(1) 针对您的应用选择合适的 TI 产品，(2) 设计、验证并测试您的应用，(3) 确保您的应用满足相应标准以及任何其他安全、安保法规或其他要求。

这些资源如有变更，恕不另行通知。TI 授权您仅可将这些资源用于研发本资源所述的 TI 产品的相关应用。严禁以其他方式对这些资源进行复制或展示。您无权使用任何其他 TI 知识产权或任何第三方知识产权。对于因您对这些资源的使用而对 TI 及其代表造成的任何索赔、损害、成本、损失和债务，您将全额赔偿，TI 对此概不负责。

TI 提供的产品受 [TI 销售条款](#)、[TI 通用质量指南](#) 或 [ti.com](#) 上其他适用条款或 TI 产品随附的其他适用条款的约束。TI 提供这些资源并不会扩展或以其他方式更改 TI 针对 TI 产品发布的适用的担保或担保免责声明。除非德州仪器 (TI) 明确将某产品指定为定制产品或客户特定产品，否则其产品均为按确定价格收入目录的标准通用器件。

TI 反对并拒绝您可能提出的任何其他或不同的条款。

版权所有 © 2026，德州仪器 (TI) 公司

最后更新日期：2025 年 10 月