

AWR2243 Evaluation Module (AWR2243BOOST) mmWave Sensing Solution

User's Guide



Literature Number: SPRUIT8D
FEBRUARY 2020 – REVISED FEBRUARY 2021

1 Getting Started	7
1.1 Introduction.....	7
1.2 Key Features.....	7
1.3 What is Included.....	7
2 Hardware	9
2.1 Block Diagram.....	10
2.2 Connecting BoosterPack™ to LaunchPad™ or MMWAVE-DEVPACK.....	11
2.3 Power Connections.....	12
2.4 Connectors.....	12
2.5 PC Connection.....	16
2.6 Antenna.....	17
2.7 Jumpers, Switches, and LEDs.....	19
3 Design Files and Software Tools	23
3.1 LDO Bypass Requirement.....	23
4 Design Revision History	25
5 Mechanical Mounting of PCB	27
6 PCB Storage and Handling Recommendations	29
7 Regulatory Information	31
Revision History	32

List of Figures

Figure 2-1. EVM Front View.....	9
Figure 2-2. EVM Rear View.....	10
Figure 2-3. BoosterPack™ Block Diagram.....	10
Figure 2-4. 3V3 and 5-V Mark on the LaunchPad™ (White Triangle).....	11
Figure 2-5. Power Connector.....	12
Figure 2-6. 20-Pin BoosterPack™ Connectors (J5 and J6).....	13
Figure 2-7. High Density Connector (60 Pin).....	15
Figure 2-8. XDS110 Ports.....	16
Figure 2-9. PCB Antenna.....	17
Figure 2-10. Antenna Pattern in H-Plane.....	18
Figure 2-11. Antenna Pattern in E-Plane.....	18
Figure 2-12. SOP Jumpers.....	19
Figure 2-13. Current Measurement Point.....	19
Figure 2-14. S1 Switch to Select Between SPI or CAN Interface.....	21
Figure 3-1. LDO Bypass Enable.....	24
Figure 5-1. Vertical Assembly of the EVM.....	27

List of Tables

Table 2-1. 20-Pin Connector Definition (J6).....	14
Table 2-2. 20-Pin Connector Definition (J5).....	14
Table 2-3. HD Connector Pin Definition.....	15
Table 2-4. SOP Modes.....	19
Table 2-5. Push Buttons.....	20
Table 2-6. LEDs.....	20
Table 4-1. Design Revision History.....	25

This page intentionally left blank.

Trademarks

BoosterPack™ and LaunchPad™ are trademarks of Texas Instruments.
Windows® is a registered trademark of Microsoft Corporation.
All trademarks are the property of their respective owners.

This page intentionally left blank.

1.1 Introduction

The AWR2243 BoosterPack™ is an evaluation board for the AWR2243 mmWave high-performance front end. The evaluation platform enables raw capture of ADC data from the front end and evaluation of RF performance.

1.2 Key Features

- 40-pin LaunchPad™ standard that leverages the LaunchPad ecosystem
- Backchannel UART through USB to PC, for logging purposes
- Onboard antenna
- 60-pin high density (HD) connector, for raw ADC data over CSI, or the high-speed debug interface
- One button and two LEDs, for user interaction
- 5-V power jack, to power the board

1.3 What is Included

1.3.1 Kit Contents

- AWR2243BOOST
- Mounting brackets, screws, and nuts, to allow placing the PCB vertical
- Micro USB cable to connect to the PC

Note

Not included: 5 V, >2.5-A supply brick with 2.1-mm barrel jack (center positive). TI recommends using an external power supply that complies with applicable regional safety standards such as UL, CSA, VDE, CCC, PSE, and so on. The cable length of the power cord must be < 3 m.

1.3.2 mmWave Proximity Demo

TI provides sample demo codes to easily get started with the AWR2243 evaluation module and experience the functionality of the AWR2243 mmWave sensor. For details on getting started with these demos, see the [mmWave SDK User Guide](#).

This page intentionally left blank.

Figure 2-1 and Figure 2-2 show the front and rear views of the evaluation board, respectively.

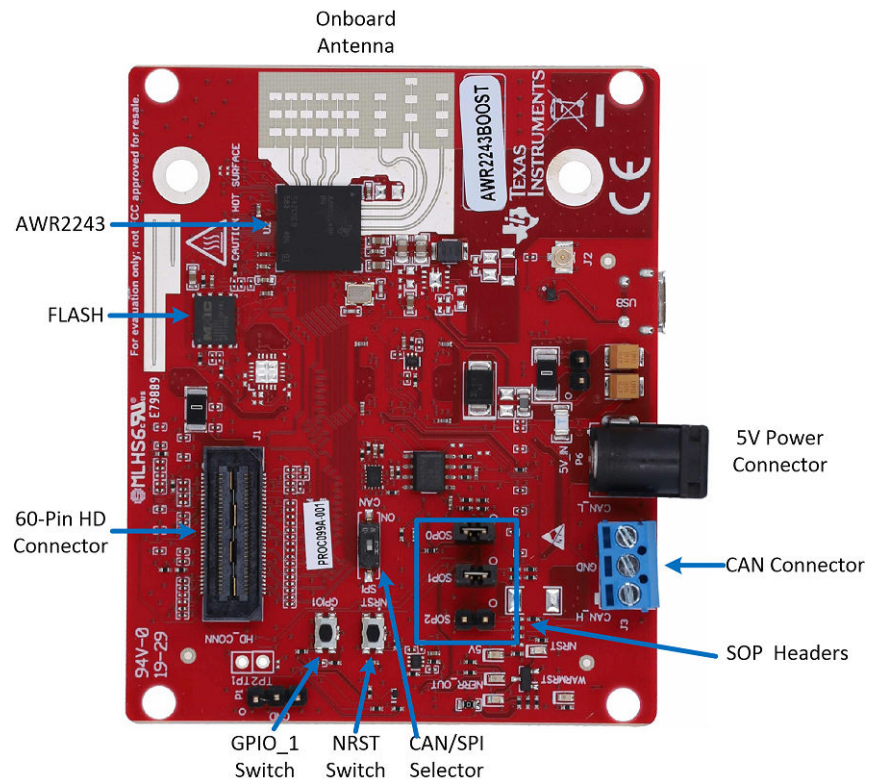

Figure 2-1. EVM Front View

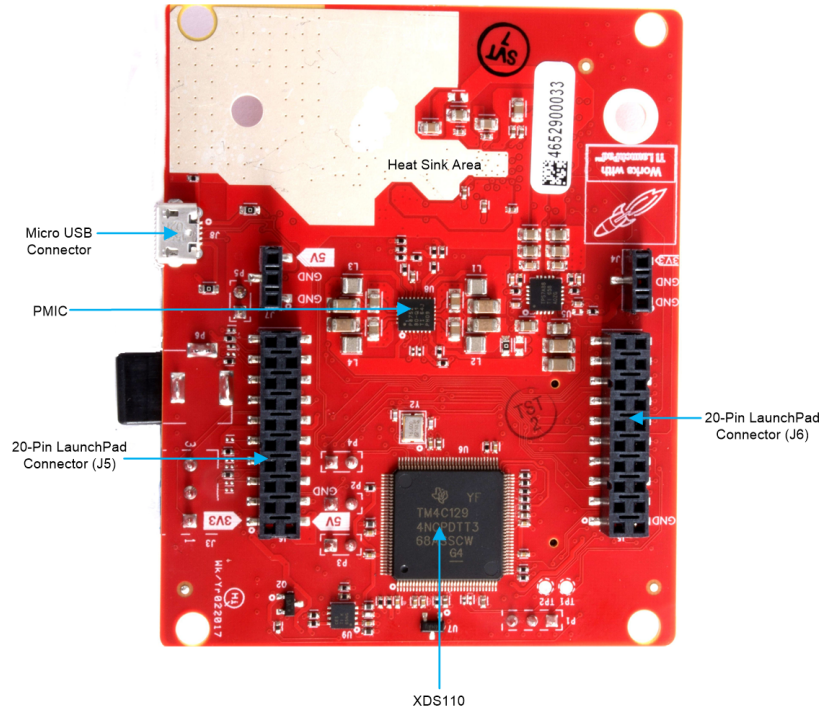

Figure 2-2. EVM Rear View

2.1 Block Diagram

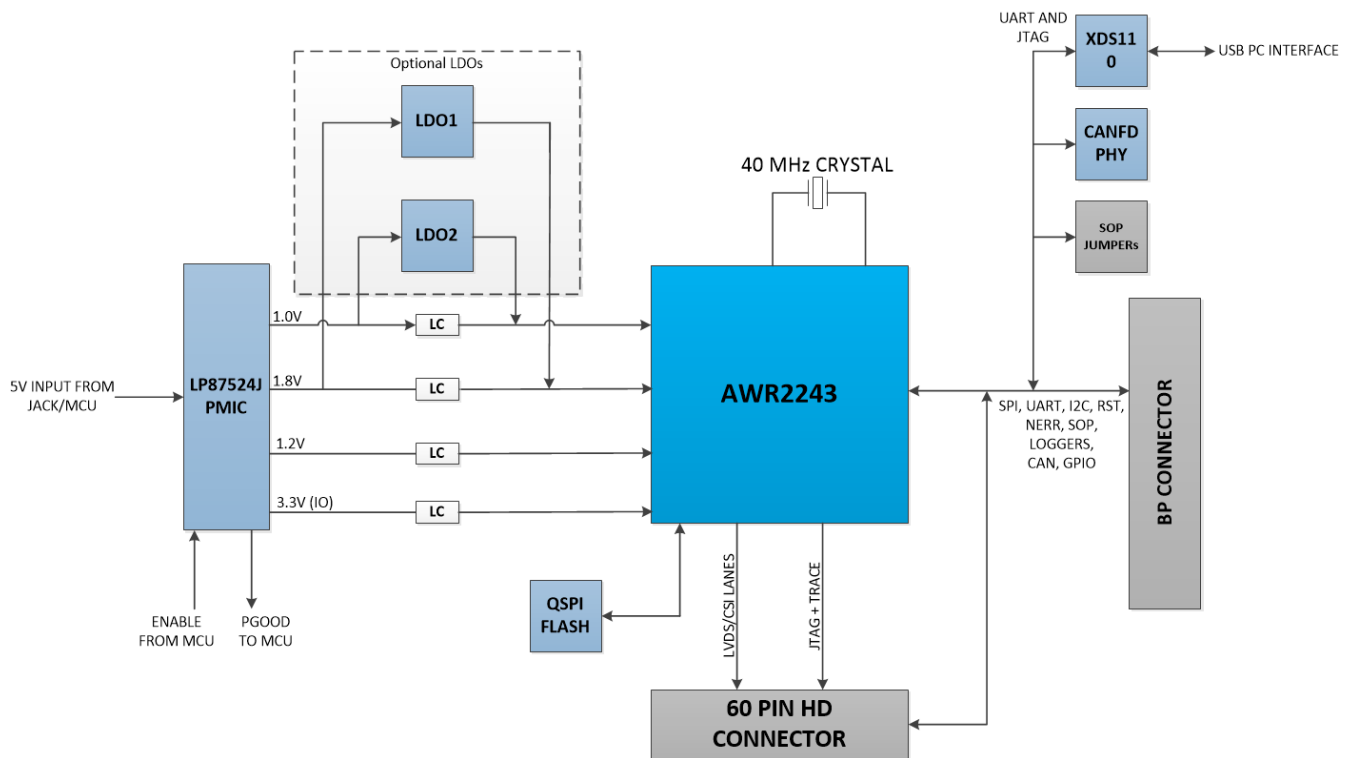

Figure 2-3. BoosterPack™ Block Diagram

Note

The AWR2243 does not support CAN communication. Because the AWR2243BOOST shares the same PCB as the AWR1443BOOST, the PCB contains a CAN connector (J3) and CAN PHY (U3); however, the connector and PHY are not functional. The SPI/CAN selector switch (refer to [Section 2.7.4](#) for more details) should always be set to 'SPI' mode on the AWR2243BOOST.

2.2 Connecting BoosterPack™ to LaunchPad™ or MMWAVE-DEVPACK

This BoosterPack can be stacked on top of the Launchpad, or the [MMWAVE-DEVPACK](#), using the two 20-pin connectors. The connectors do not have a key to prevent the misalignment of the pins or reverse connection. Therefore, ensure reverse mounting does not take place. On the AWR2243 BoosterPack, we have provided 3V3 marking near pin 1 (see [Figure 2-4](#)). This same marking is provided on compatible LaunchPads which must be aligned before powering up the boards.

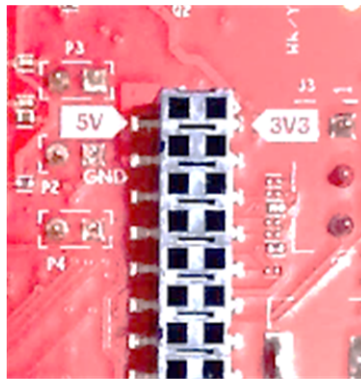

Figure 2-4. 3V3 and 5-V Mark on the LaunchPad™ (White Triangle)

2.3 Power Connections

The BoosterPack is powered by the 5-V power jack (>2.5-A current limit). As soon as the power is provided, the NRST and 5-V LEDs glow, indicating that the board is powered up (see [Figure 2-5](#)).

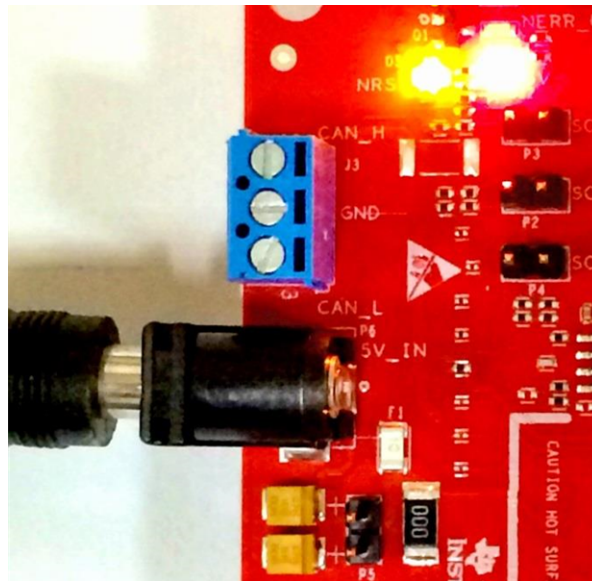

Figure 2-5. Power Connector

Note

After the 5-V power supply is provided to the EVM, TI recommends pressing the NRST switch (SW2) once to ensure a reliable boot up state.

2.4 Connectors

2.4.1 20-Pin BoosterPack™ Connectors

The BoosterPack has the standard LaunchPad connectors (J5 and J6) which enable the BoosterPack to be directly connected to all TI MCU LaunchPads (see [Table 2-1](#)). While connecting the BoosterPack to other LaunchPads, ensure the pin 1 orientation is correct by matching the 3V3 and 5-V signal marking on the boards (see [Figure 2-6](#)).

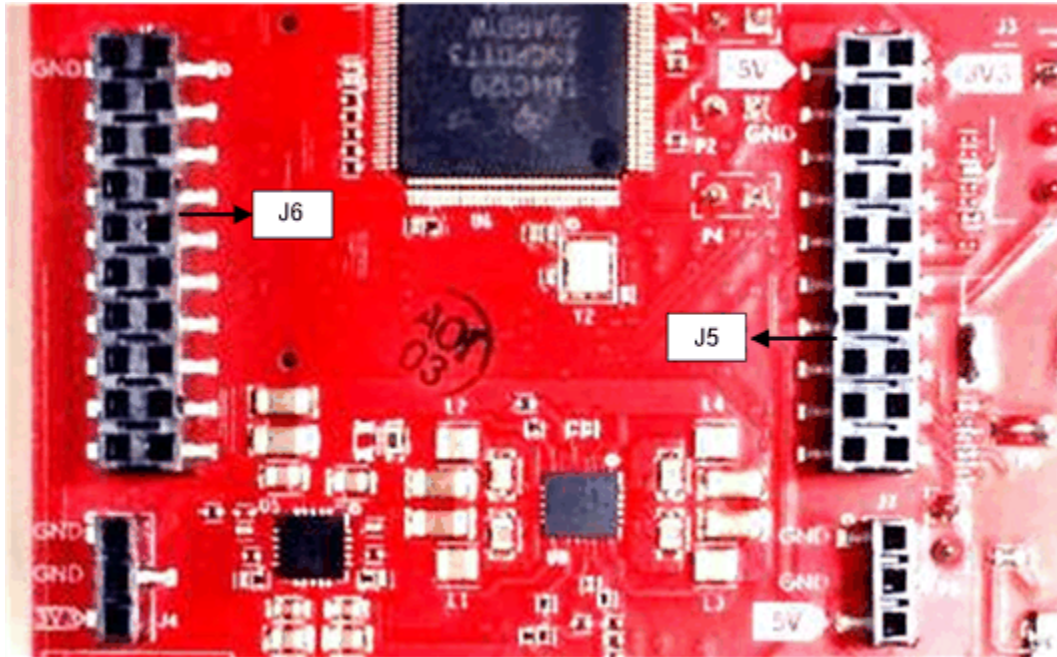

Figure 2-6. 20-Pin BoosterPack™ Connectors (J5 and J6)

Table 2-1 and Table 2-2 provide the connector-pin information.

Table 2-1. 20-Pin Connector Definition (J6)

Pin Number	Description	Pin Number	Description
1	NERROUT	2	GND
3	NERRIN	4	NC
5	MCUCLK OUT	6	SPI_CS
7	NC	8	GPIO1
9	MSS LOGGER	10	nRESET
11	WARMRST	12	SPI_MOSI
13	BSS LOGGER	14	SPI_MISO
15	SOP2	16	HOSTINT
17	SOP1	18	GPIO2
19	SOP0	20	NC

Table 2-2. 20-Pin Connector Definition (J5)

Pin Number	Description	Pin Number	Description
1	3V3	2	5 V
3	NC	4	GND
5	RS232TX (Tx from IWR device)	6	ANA1
7	RS232RX (Rx into IWR device)	8	ANA2
9	SYNC_IN	10	ANA3
11	NC	12	ANA4
13	SPI_CLK	14	PGOOD (onboard VIO)
15	GPIO0	16	PMIC Enable
17	SCL	18	SYNC_OUT
19	SDA	20	PMIC CLK OUT

- PGOOD – This signal indicates the state of the onboard VIO supply for the AWR device coming from the onboard PMIC. A high on the PGOOD signal (3.3 V) indicates that the supply is stable. Because the IOs are not failsafe, the MCU must ensure that it does not drive any IO signals to the AWR device before this IO supply is stable. Otherwise, there could be leakage current into the IOs.
- PMIC Enable – This signal goes onboard PMIC enable. The MCU can use this signal to completely shut down the PMIC and AWR device to save power. The power up of the PMIC takes approximately 5 ms once the Enable signal is released.

Note

To enable this feature, the R102 resistor must be populated on the EVM.

2.4.2 60-Pin High Density (HD) Connector

The 60-pin HD connector provides high speed data over CSI or the HS_DEBUG interface, and controls signals (SPI, UART, I2C, NRST, NERR, and SOPs) and JTAG debug signals (see [Table 2-3](#)). This connector can be connected to the MMWAVE-DEVPACK board and interface with the TSW1400 (see [Figure 2-7](#)).

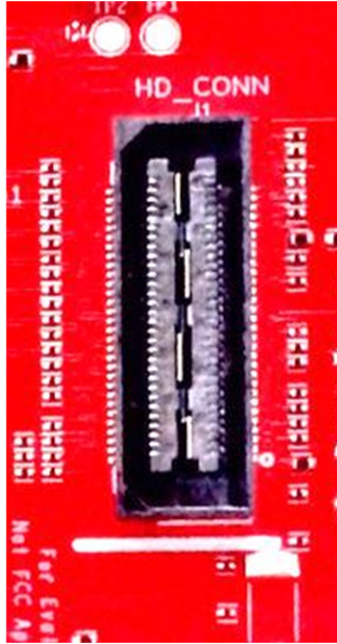

Figure 2-7. High Density Connector (60 Pin)

Table 2-3. HD Connector Pin Definition

Pin Number	Description	Pin Number	Description
1	5 V	2	5 V
3	5 V	4	TDO
5	TDI	6	TCK
7	SPI_CS	8	TMS
9	SPI_CLK	10	HOSTINT
11	SPI_MOSI	12	SPI_MISO
13	PGOOD (onboard VIO)	14	NERROUT
15	NC	16	SYNC_IN
17	NC	18	GND
19	NC	20	DEBUG_VALIDP
21	NC	22	DEBUG_VALIDM
23	NC	24	GND
25	NC	26	DEBUG_FRCLKP
27	NC	28	DEBUG_FRCLKM
29	NC	30	GND
31	NC	32	DEBUG/CSI_3P
33	NC	34	DEBUG/CSI_3M
35	NC	36	GND
37	NC	38	DEBUG/CSI_2P
39	NC	40	DEBUG/CSI_2M
41	NC	42	GND

Table 2-3. HD Connector Pin Definition (continued)

Pin Number	Description	Pin Number	Description
43	NC	44	DEBUG/CSI_CLKP
45	NC	46	DEBUG/CSI_CLKM
47	NC	48	GND
49	NC	50	DEBUG/CSI_1P
51	I2C_SDA	52	DEBUG/CSI_1M
53	I2C_SCL	54	GND
55	RS232RX (Rx into AWR device)	56	DEBUG/CSI_0P
57	RS232TX (Tx from AWR device)	58	DEBUG/CSI_0M
59	nRESET	60	GND

PGOOD – This signal indicates that the state of the onboard VIO supply for the AWR device coming from the onboard PMIC. A high on the PGOOD signal (3.3 V) indicates the supply is stable. Because the I/Os are not failsafe, the MCU must ensure that it does not drive any I/O signals to the AWR device before this I/O supply is stable, to avoid leakage current into the I/Os.

2.5 PC Connection

Connectivity is provided using the micro USB connector over the onboard XDS110 (TM4C1294NCPDT) emulator. This connection provides the following interfaces to the PC:

- JTAG for CCS connectivity
- UART1 for flashing the onboard serial flash, downloading FW using RADAR studio, and getting application data sent over the UART
- MSS logger UART, which can be used to get MSS code logs on the PC

When the USB is connected to the PC the device manager recognizes the following COM ports, as shown in [Figure 2-8](#):

- XDS110 Class Application/User UART → the UART1 port
- XDS110 Class Auxiliary Data port → the MSS logger port

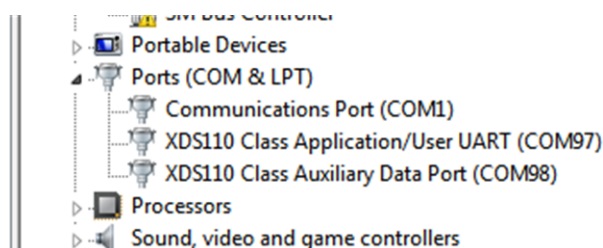
**Figure 2-8. XDS110 Ports**

If Windows® is unable to recognize the COM ports previously shown, install the emupack available [here](#)

2.5.1 Erasing Onboard Serial Flash

Before loading the code to the serial flash or connecting the board to RADAR Studio, TI recommends completely erasing the onboard serial flash. The instructions to erase the onboard serial flash are in the [mmWave SDK User Guide](#).

2.5.2 Connection With MMWAVE-DEVPACK

Mmwave SDK demos and released labs do not require the DevPack to be used with the BoosterPack. Users may be required to use the DevPack along with the BoosterPack for the following use cases:

- Connecting to RADAR studio. This tool provides capability to configure the mmWave front end from the PC. This tool is available in the [DFP package](#).
- Capturing high-speed LVDS data using the TSW1400 platform from TI. This device allows the user to capture raw ADC data over the high-speed debug interface and post process it in the PC. The RADAR Studio tool provides an interface to the TSW1400 platform as well, so that the front end configurations and data capture can be done using a single interface. Details on this board can be found at <http://www.ti.com/tool/tsw1400evm>

For details on these use cases, see the [mmWave-DevPack User Guide](#).

2.5.3 Connecting the BoosterPack to the DCA1000

The BoosterPack can be connected to the DCA1000 FPGA platform for LVDS streaming over Ethernet. For detailed information on how to capture LVDS data using the DCA1000, see the following resources:

- [DCA1000 Product Page](#)
- [DCA1000 User's Guide](#)
- [DCA1000 Training Video](#)

2.6 Antenna

The BoosterPack includes onboard etched antennas for the four receivers and three transmitters, which enables tracking multiple objects with their distance and angle information. This antenna design enables estimation of both azimuth and elevation angles, which enables object detection in a 3-D plane (see [Figure 2-9](#)).

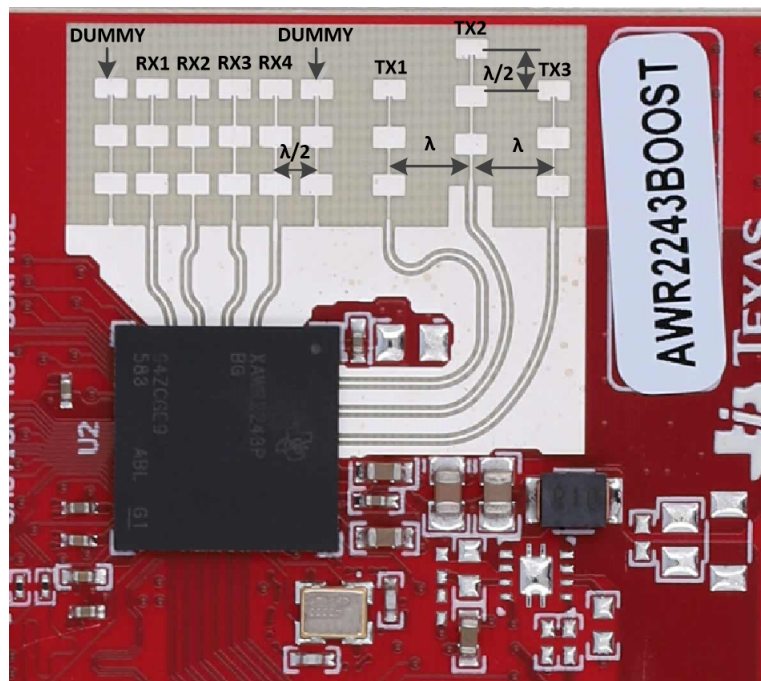

Figure 2-9. PCB Antenna

The antenna peak gain is > 10.5 dBi across the frequency band of 76 to 81 GHz. The radiation pattern of the antenna in the horizontal plan (H-plane) and elevation plan (E-plane) is as shown in [Figure 2-10](#) and [Figure 2-11](#).

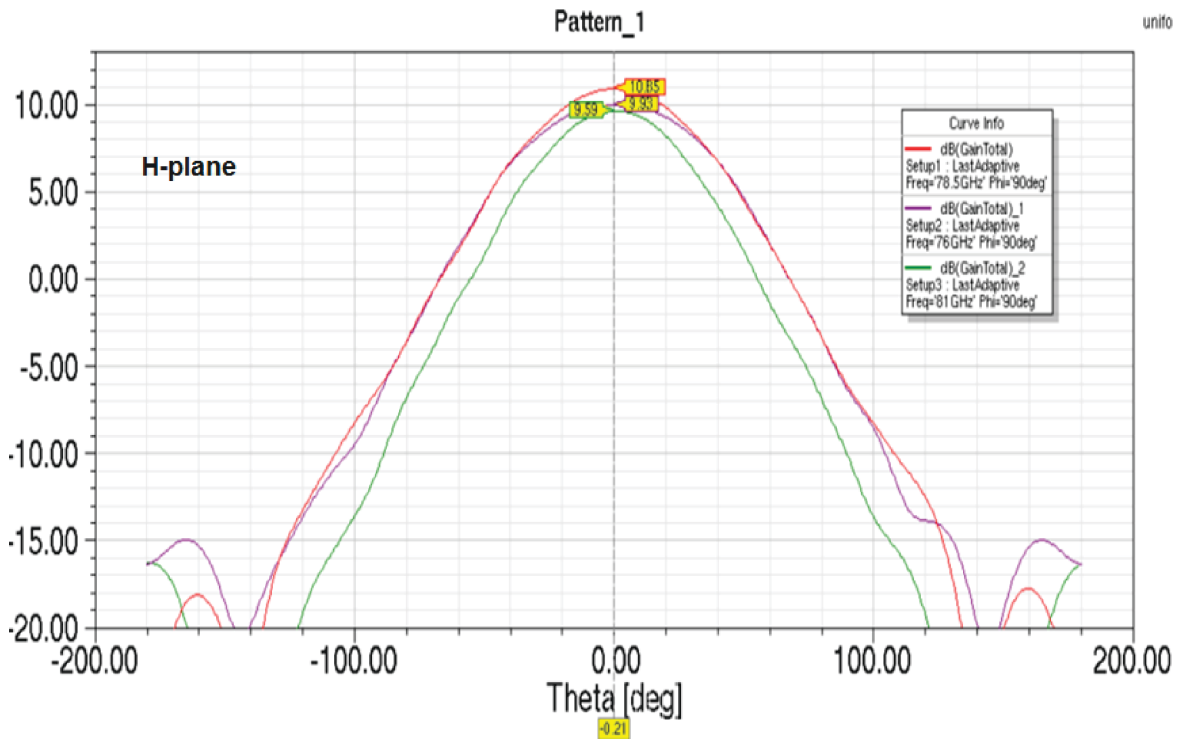

Figure 2-10. Antenna Pattern in H-Plane

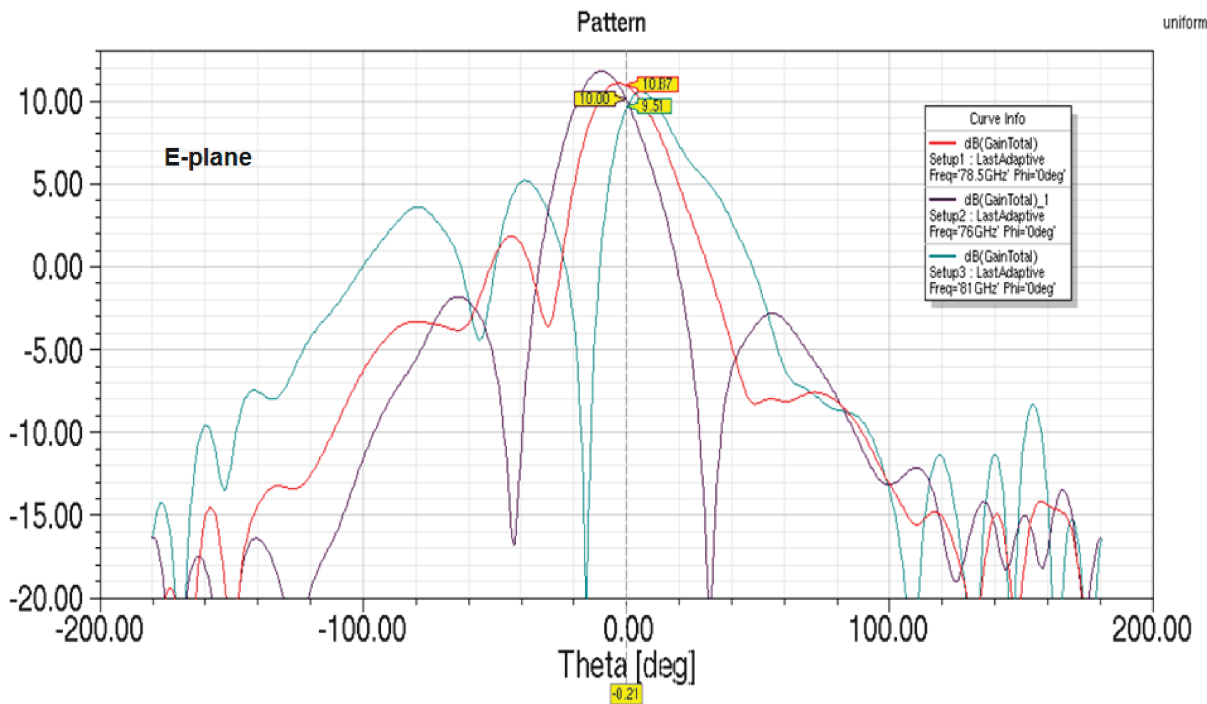

Figure 2-11. Antenna Pattern in E-Plane

2.7 Jumpers, Switches, and LEDs

2.7.1 Sense On Power Jumpers

The AWR2243 device can be set to operate in three different modes, based on the state of the SOP (sense on power) lines (see [Figure 2-12](#)). These lines are *only* sensed during boot up of the AWR device. The state of the device is described by [Table 2-4](#).

A closed jumper refers to a 1 and an open jumper refers to a 0 state of the SOP signal going to the AWR device.

Table 2-4. SOP Modes

Reference	Use	Comments
P3 (SOP 2)	SOP[2:0]	101 (SOP mode 5) = Flash programming 001 (SOP mode 4) = Functional mode 011 (SOP mode 2) = Dev mode
P2 (SOP 1)		
P4 (SOP 0)		



Figure 2-12. SOP Jumpers

2.7.2 Current Measurement

The P5 jumper enables measurement of the current being consumed by the reference design (AWR device + PMIC + LDOs) at the 5-V level.

To measure the current, R118 must be removed and a series ammeter can be put across the P5 pins (see [Figure 2-13](#)).



Figure 2-13. Current Measurement Point

2.7.3 Push Buttons and LEDs

Table 2-5 and Table 2-6 list the push button and LED uses, respectively.

Table 2-5. Push Buttons







Reference	Use	Comments	Image
SW2	RESET	This button is used to reset the radar device. This signal is also brought out on the 20-pin connector and 60-pin HD connector, so that an external processor can control the AWR device. The onboard XDS110 can also use this reset.	
SW1	GPIO_1	When this button is pushed, the GPIO_1 is pulled to V _{CC} .	

Table 2-6. LEDs

Reference	Color	Use	Comments	Image
DS2	Red	5-V supply indication	This LED indicates the presence of the 5-V supply.	
DS4	Yellow	nRESET	This LED is used to indicate the state of nRESET pin. If this LED is on, the device is out of reset. This LED glows only after the 5-V supply is provided.	
DS1	Red	NERR_OUT	This LED turns on if there is any hardware error in the AWR device.	
DS3	Yellow	GPIO_1	This LED turns on when the GPIO is logic-1.	

2.7.4 Selection Between SPI and CAN Interface

The AWR2243BOOST contains a SPI/CAN selector switch (S1) shown in Figure 2-14. However, the AWR2243 does not support CAN communication, so this switch should always be set to the 'SPI' position to bring out the SPI interface to the HD connector (J1). For more details on the HD connector, refer to Section 2.4.2.

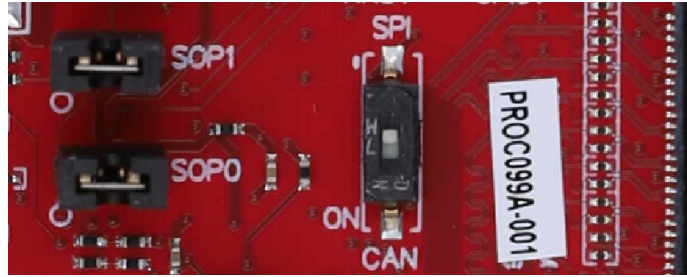

Figure 2-14. S1 Switch to Select Between SPI or CAN Interface

This page intentionally left blank.

For Rev A boards:

- [AWR2243BOOST Schematics, Assembly, and BOM Details](#)
- [AWR2243BOOST Design Database and Layout Details](#)

Note

Boards with a Rev 'B' sticker have had capacitor C56 (VBGAP decoupling capacitor) changed from 0.22 μ F to 0.047 μ F (part number CGA2B3X7R1H473K050BB). TI recommends that customers incorporate this change with an equivalent capacitor in their designs.

3.1 LDO Bypass Requirement

The AWR2243BOOST uses a 1.0-V supply on the RF1 and RF2 power rails. To support the third transmitter, the VOUT_PA output is connected to the RF2 power rail. For best performance and to prevent damage to the device, select the 'RF LDO Bypass Enable' and 'PA LDO I/P Disable' options in the Static Configuration when using mmWave Studio. Additionally, the LDO bypass can be configured using the AWR_RF_LDO_BYPASS_SB API. To enable the RF LDO Bypass and PA LDO I/P Disable through the API, issue an `ar1.RfLdoBypassConfig(0x3)` command.

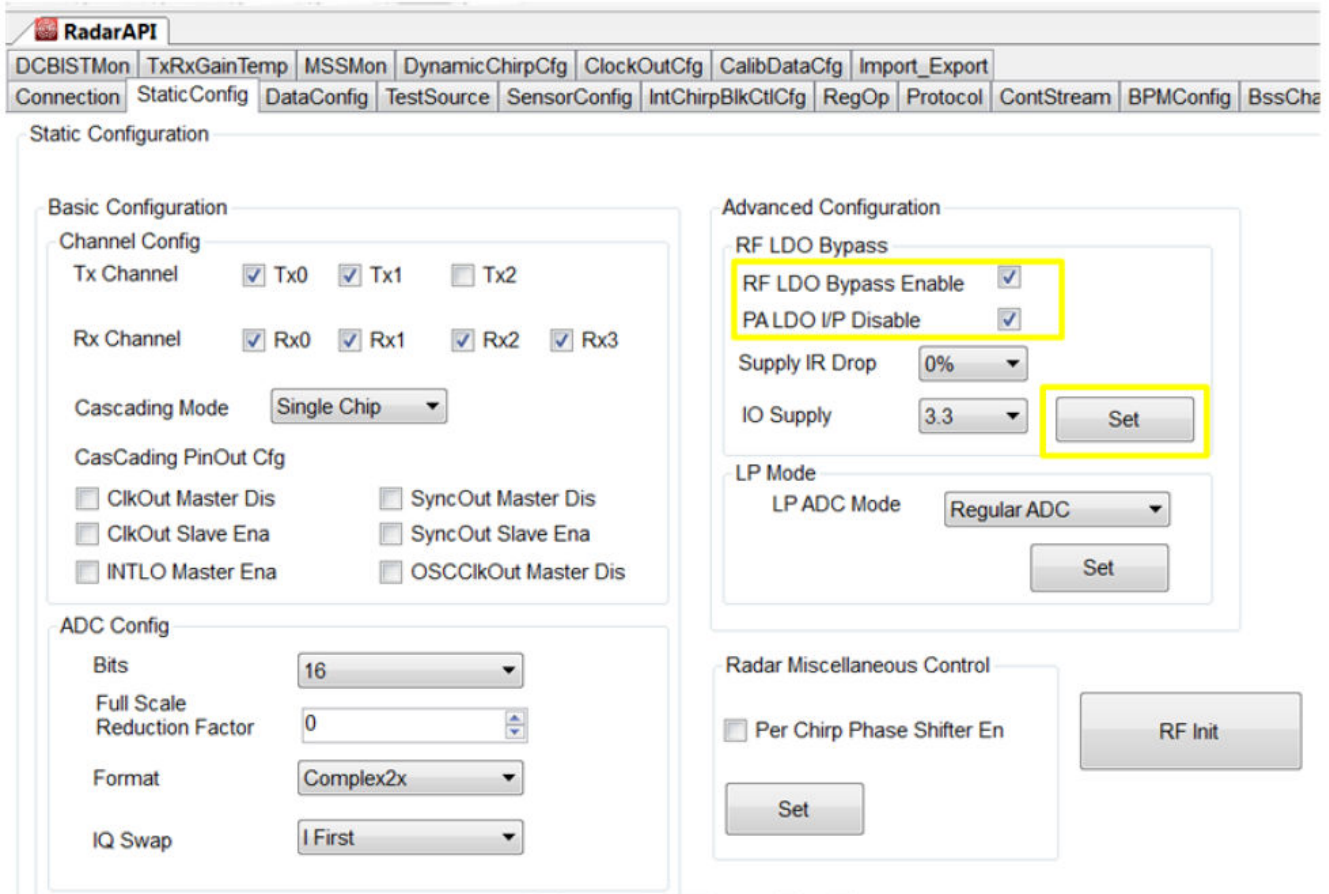

Figure 3-1. LDO Bypass Enable

Table 4-1. Design Revision History

PCB Revision	Notes
B	Added switch control to move between SPI and CAN interface
	Enabled, by default, the 5-V supply from the 60-pin HD connector
	Enabled, by default, the SYNC_IN signal connection to the J6 connector
	Serial flash part number updated to MX25V1635FZNQ
	Added series resistors on I2C lines
	Removed the series diode on the NRST signal
	Enabled, by default, the LDO bypass option

This page intentionally left blank.

The field of view of the radar sensor is orthogonal to the PCB. The L-brackets provided with the AWR2243 EVM kit, along with the screws and nuts help in the vertical mounting of the EVM. [Figure 5-1](#) shows how the L-brackets can be assembled.

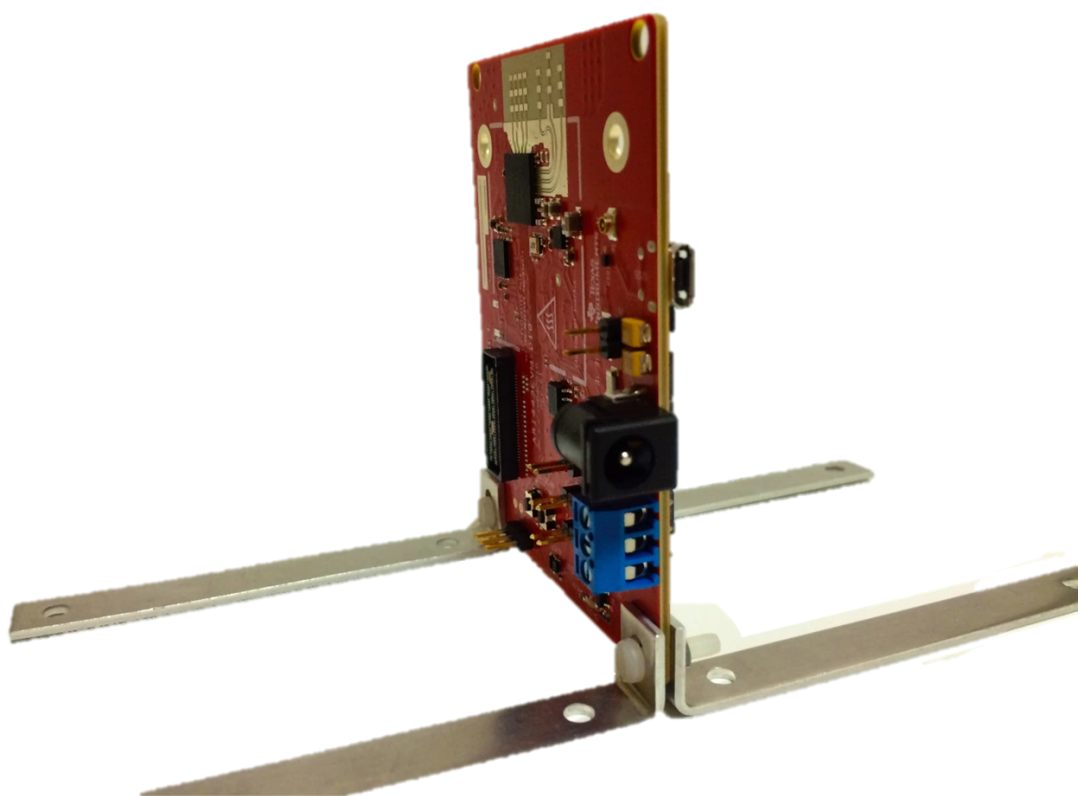

Figure 5-1. Vertical Assembly of the EVM

This page intentionally left blank.

PCB Storage and Handling Recommendations

The immersion silver finish of the PCB provides a better high-frequency performance but is also prone to oxidation in an open environment. This oxidation causes the surface around the antenna region to blacken. To avoid this effect, store the PCB in an ESD cover and keep it at controlled room temperature with low humidity conditions. All ESD precautions must be taken while using and handling the EVM.

This page intentionally left blank.

Developers and integrators that incorporate the chipset in any end products are responsible for obtaining applicable regulatory approvals for such an end product.

The European RF exposure radiation limit is fulfilled if a minimum distance of 5 cm between the users body and the radio transmitter is respected.

Note

The EUT has been tested in the 76 – 77 GHz band (2 Tx at a time) at a maximum peak power of 26 dBm EIRP, and in the 77 – 81 GHz band (1 Tx at a time) with maximum peak power of 21 dBm EIRP across the temperature range of –20°C to 60°C.

NOTE: Page numbers for previous revisions may differ from page numbers in the current version.

Changes from May 1, 2020 to February 28, 2021 (from Revision C (April 2020) to Revision D (February 2021))

Page

-
- Added Note.....10
 - Updated Selection Between SPI and CAN Interface section.....20
-

STANDARD TERMS FOR EVALUATION MODULES

1. *Delivery:* TI delivers TI evaluation boards, kits, or modules, including any accompanying demonstration software, components, and/or documentation which may be provided together or separately (collectively, an "EVM" or "EVMs") to the User ("User") in accordance with the terms set forth herein. User's acceptance of the EVM is expressly subject to the following terms.
 - 1.1 EVMs are intended solely for product or software developers for use in a research and development setting to facilitate feasibility evaluation, experimentation, or scientific analysis of TI semiconductor products. EVMs have no direct function and are not finished products. EVMs shall not be directly or indirectly assembled as a part or subassembly in any finished product. For clarification, any software or software tools provided with the EVM ("Software") shall not be subject to the terms and conditions set forth herein but rather shall be subject to the applicable terms that accompany such Software
 - 1.2 EVMs are not intended for consumer or household use. EVMs may not be sold, sublicensed, leased, rented, loaned, assigned, or otherwise distributed for commercial purposes by Users, in whole or in part, or used in any finished product or production system.
2. *Limited Warranty and Related Remedies/Disclaimers:*
 - 2.1 These terms do not apply to Software. The warranty, if any, for Software is covered in the applicable Software License Agreement.
 - 2.2 TI warrants that the TI EVM will conform to TI's published specifications for ninety (90) days after the date TI delivers such EVM to User. Notwithstanding the foregoing, TI shall not be liable for a nonconforming EVM if (a) the nonconformity was caused by neglect, misuse or mistreatment by an entity other than TI, including improper installation or testing, or for any EVMs that have been altered or modified in any way by an entity other than TI, (b) the nonconformity resulted from User's design, specifications or instructions for such EVMs or improper system design, or (c) User has not paid on time. Testing and other quality control techniques are used to the extent TI deems necessary. TI does not test all parameters of each EVM. User's claims against TI under this Section 2 are void if User fails to notify TI of any apparent defects in the EVMs within ten (10) business days after delivery, or of any hidden defects with ten (10) business days after the defect has been detected.
 - 2.3 TI's sole liability shall be at its option to repair or replace EVMs that fail to conform to the warranty set forth above, or credit User's account for such EVM. TI's liability under this warranty shall be limited to EVMs that are returned during the warranty period to the address designated by TI and that are determined by TI not to conform to such warranty. If TI elects to repair or replace such EVM, TI shall have a reasonable time to repair such EVM or provide replacements. Repaired EVMs shall be warranted for the remainder of the original warranty period. Replaced EVMs shall be warranted for a new full ninety (90) day warranty period.

WARNING

Evaluation Kits are intended solely for use by technically qualified, professional electronics experts who are familiar with the dangers and application risks associated with handling electrical mechanical components, systems, and subsystems.

User shall operate the Evaluation Kit within TI's recommended guidelines and any applicable legal or environmental requirements as well as reasonable and customary safeguards. Failure to set up and/or operate the Evaluation Kit within TI's recommended guidelines may result in personal injury or death or property damage. Proper set up entails following TI's instructions for electrical ratings of interface circuits such as input, output and electrical loads.

NOTE:

EXPOSURE TO ELECTROSTATIC DISCHARGE (ESD) MAY CAUSE DEGRADATION OR FAILURE OF THE EVALUATION KIT; TI RECOMMENDS STORAGE OF THE EVALUATION KIT IN A PROTECTIVE ESD BAG.

3 Regulatory Notices:

3.1 United States

3.1.1 Notice applicable to EVMs not FCC-Approved:

FCC NOTICE: This kit is designed to allow product developers to evaluate electronic components, circuitry, or software associated with the kit to determine whether to incorporate such items in a finished product and software developers to write software applications for use with the end product. This kit is not a finished product and when assembled may not be resold or otherwise marketed unless all required FCC equipment authorizations are first obtained. Operation is subject to the condition that this product not cause harmful interference to licensed radio stations and that this product accept harmful interference. Unless the assembled kit is designed to operate under part 15, part 18 or part 95 of this chapter, the operator of the kit must operate under the authority of an FCC license holder or must secure an experimental authorization under part 5 of this chapter.

3.1.2 For EVMs annotated as FCC – FEDERAL COMMUNICATIONS COMMISSION Part 15 Compliant:

CAUTION

This device complies with part 15 of the FCC Rules. Operation is subject to the following two conditions: (1) This device may not cause harmful interference, and (2) this device must accept any interference received, including interference that may cause undesired operation.

Changes or modifications not expressly approved by the party responsible for compliance could void the user's authority to operate the equipment.

FCC Interference Statement for Class A EVM devices

NOTE: This equipment has been tested and found to comply with the limits for a Class A digital device, pursuant to part 15 of the FCC Rules. These limits are designed to provide reasonable protection against harmful interference when the equipment is operated in a commercial environment. This equipment generates, uses, and can radiate radio frequency energy and, if not installed and used in accordance with the instruction manual, may cause harmful interference to radio communications. Operation of this equipment in a residential area is likely to cause harmful interference in which case the user will be required to correct the interference at his own expense.

FCC Interference Statement for Class B EVM devices

NOTE: This equipment has been tested and found to comply with the limits for a Class B digital device, pursuant to part 15 of the FCC Rules. These limits are designed to provide reasonable protection against harmful interference in a residential installation. This equipment generates, uses and can radiate radio frequency energy and, if not installed and used in accordance with the instructions, may cause harmful interference to radio communications. However, there is no guarantee that interference will not occur in a particular installation. If this equipment does cause harmful interference to radio or television reception, which can be determined by turning the equipment off and on, the user is encouraged to try to correct the interference by one or more of the following measures:

- Reorient or relocate the receiving antenna.
- Increase the separation between the equipment and receiver.
- Connect the equipment into an outlet on a circuit different from that to which the receiver is connected.
- Consult the dealer or an experienced radio/TV technician for help.

3.2 Canada

3.2.1 For EVMs issued with an Industry Canada Certificate of Conformance to RSS-210 or RSS-247

Concerning EVMs Including Radio Transmitters:

This device complies with Industry Canada license-exempt RSSs. Operation is subject to the following two conditions:

(1) this device may not cause interference, and (2) this device must accept any interference, including interference that may cause undesired operation of the device.

Concernant les EVMs avec appareils radio:

Le présent appareil est conforme aux CNR d'Industrie Canada applicables aux appareils radio exempts de licence. L'exploitation est autorisée aux deux conditions suivantes: (1) l'appareil ne doit pas produire de brouillage, et (2) l'utilisateur de l'appareil doit accepter tout brouillage radioélectrique subi, même si le brouillage est susceptible d'en compromettre le fonctionnement.

Concerning EVMs Including Detachable Antennas:

Under Industry Canada regulations, this radio transmitter may only operate using an antenna of a type and maximum (or lesser) gain approved for the transmitter by Industry Canada. To reduce potential radio interference to other users, the antenna type and its gain should be so chosen that the equivalent isotropically radiated power (e.i.r.p.) is not more than that necessary for successful communication. This radio transmitter has been approved by Industry Canada to operate with the antenna types listed in the user guide with the maximum permissible gain and required antenna impedance for each antenna type indicated. Antenna types not included in this list, having a gain greater than the maximum gain indicated for that type, are strictly prohibited for use with this device.

Concernant les EVMs avec antennes détachables

Conformément à la réglementation d'Industrie Canada, le présent émetteur radio peut fonctionner avec une antenne d'un type et d'un gain maximal (ou inférieur) approuvé pour l'émetteur par Industrie Canada. Dans le but de réduire les risques de brouillage radioélectrique à l'intention des autres utilisateurs, il faut choisir le type d'antenne et son gain de sorte que la puissance isotrope rayonnée équivalente (p.i.r.e.) ne dépasse pas l'intensité nécessaire à l'établissement d'une communication satisfaisante. Le présent émetteur radio a été approuvé par Industrie Canada pour fonctionner avec les types d'antenne énumérés dans le manuel d'usage et ayant un gain admissible maximal et l'impédance requise pour chaque type d'antenne. Les types d'antenne non inclus dans cette liste, ou dont le gain est supérieur au gain maximal indiqué, sont strictement interdits pour l'exploitation de l'émetteur.

3.3 Japan

3.3.1 *Notice for EVMs delivered in Japan:* Please see http://www.tij.co.jp/lstds/ti_ja/general/eStore/notice_01.page 日本国内に輸入される評価用キット、ボードについては、次のところをご覧ください。

<https://www.ti.com/ja-jp/legal/notice-for-evaluation-kits-delivered-in-japan.html>

3.3.2 *Notice for Users of EVMs Considered "Radio Frequency Products" in Japan:* EVMs entering Japan may not be certified by TI as conforming to Technical Regulations of Radio Law of Japan.

If User uses EVMs in Japan, not certified to Technical Regulations of Radio Law of Japan, User is required to follow the instructions set forth by Radio Law of Japan, which includes, but is not limited to, the instructions below with respect to EVMs (which for the avoidance of doubt are stated strictly for convenience and should be verified by User):

1. Use EVMs in a shielded room or any other test facility as defined in the notification #173 issued by Ministry of Internal Affairs and Communications on March 28, 2006, based on Sub-section 1.1 of Article 6 of the Ministry's Rule for Enforcement of Radio Law of Japan,
2. Use EVMs only after User obtains the license of Test Radio Station as provided in Radio Law of Japan with respect to EVMs, or
3. Use of EVMs only after User obtains the Technical Regulations Conformity Certification as provided in Radio Law of Japan with respect to EVMs. Also, do not transfer EVMs, unless User gives the same notice above to the transferee. Please note that if User does not follow the instructions above, User will be subject to penalties of Radio Law of Japan.

【無線電波を送信する製品の開発キットをお使いになる際の注意事項】 開発キットの中には技術基準適合証明を受けていないものがあります。技術適合証明を受けていないものご使用に際しては、電波法遵守のため、以下のいずれかの措置を取っていただく必要がありますのでご注意ください。

1. 電波法施行規則第6条第1項第1号に基づく平成18年3月28日総務省告示第173号で定められた電波暗室等の試験設備でご使用いただく。
2. 実験局の免許を取得後ご使用いただく。
3. 技術基準適合証明を取得後ご使用いただく。

なお、本製品は、上記の「ご使用にあたっての注意」を譲渡先、移転先に通知しない限り、譲渡、移転できないものとします。

上記を遵守頂けない場合は、電波法の罰則が適用される可能性があることをご留意ください。日本テキサス・イ

ンスツルメンツ株式会社

東京都新宿区西新宿 6 丁目 2 4 番 1 号

西新宿三井ビル

3.3.3 *Notice for EVMs for Power Line Communication:* Please see http://www.tij.co.jp/lstds/ti_ja/general/eStore/notice_02.page

電力線搬送波通信についての開発キットをお使いになる際の注意事項については、次のところをご覧ください。 <https://www.ti.com/ja-jp/legal/notice-for-evaluation-kits-for-power-line-communication.html>

3.4 European Union

3.4.1 *For EVMs subject to EU Directive 2014/30/EU (Electromagnetic Compatibility Directive):*

This is a class A product intended for use in environments other than domestic environments that are connected to a low-voltage power-supply network that supplies buildings used for domestic purposes. In a domestic environment this product may cause radio interference in which case the user may be required to take adequate measures.

-
- 4 *EVM Use Restrictions and Warnings:*
 - 4.1 EVMS ARE NOT FOR USE IN FUNCTIONAL SAFETY AND/OR SAFETY CRITICAL EVALUATIONS, INCLUDING BUT NOT LIMITED TO EVALUATIONS OF LIFE SUPPORT APPLICATIONS.
 - 4.2 User must read and apply the user guide and other available documentation provided by TI regarding the EVM prior to handling or using the EVM, including without limitation any warning or restriction notices. The notices contain important safety information related to, for example, temperatures and voltages.
 - 4.3 *Safety-Related Warnings and Restrictions:*
 - 4.3.1 User shall operate the EVM within TI's recommended specifications and environmental considerations stated in the user guide, other available documentation provided by TI, and any other applicable requirements and employ reasonable and customary safeguards. Exceeding the specified performance ratings and specifications (including but not limited to input and output voltage, current, power, and environmental ranges) for the EVM may cause personal injury or death, or property damage. If there are questions concerning performance ratings and specifications, User should contact a TI field representative prior to connecting interface electronics including input power and intended loads. Any loads applied outside of the specified output range may also result in unintended and/or inaccurate operation and/or possible permanent damage to the EVM and/or interface electronics. Please consult the EVM user guide prior to connecting any load to the EVM output. If there is uncertainty as to the load specification, please contact a TI field representative. During normal operation, even with the inputs and outputs kept within the specified allowable ranges, some circuit components may have elevated case temperatures. These components include but are not limited to linear regulators, switching transistors, pass transistors, current sense resistors, and heat sinks, which can be identified using the information in the associated documentation. When working with the EVM, please be aware that the EVM may become very warm.
 - 4.3.2 EVMs are intended solely for use by technically qualified, professional electronics experts who are familiar with the dangers and application risks associated with handling electrical mechanical components, systems, and subsystems. User assumes all responsibility and liability for proper and safe handling and use of the EVM by User or its employees, affiliates, contractors or designees. User assumes all responsibility and liability to ensure that any interfaces (electronic and/or mechanical) between the EVM and any human body are designed with suitable isolation and means to safely limit accessible leakage currents to minimize the risk of electrical shock hazard. User assumes all responsibility and liability for any improper or unsafe handling or use of the EVM by User or its employees, affiliates, contractors or designees.
 - 4.4 User assumes all responsibility and liability to determine whether the EVM is subject to any applicable international, federal, state, or local laws and regulations related to User's handling and use of the EVM and, if applicable, User assumes all responsibility and liability for compliance in all respects with such laws and regulations. User assumes all responsibility and liability for proper disposal and recycling of the EVM consistent with all applicable international, federal, state, and local requirements.
 5. *Accuracy of Information:* To the extent TI provides information on the availability and function of EVMs, TI attempts to be as accurate as possible. However, TI does not warrant the accuracy of EVM descriptions, EVM availability or other information on its websites as accurate, complete, reliable, current, or error-free.
 6. *Disclaimers:*
 - 6.1 EXCEPT AS SET FORTH ABOVE, EVMS AND ANY MATERIALS PROVIDED WITH THE EVM (INCLUDING, BUT NOT LIMITED TO, REFERENCE DESIGNS AND THE DESIGN OF THE EVM ITSELF) ARE PROVIDED "AS IS" AND "WITH ALL FAULTS." TI DISCLAIMS ALL OTHER WARRANTIES, EXPRESS OR IMPLIED, REGARDING SUCH ITEMS, INCLUDING BUT NOT LIMITED TO ANY EPIDEMIC FAILURE WARRANTY OR IMPLIED WARRANTIES OF MERCHANTABILITY OR FITNESS FOR A PARTICULAR PURPOSE OR NON-INFRINGEMENT OF ANY THIRD PARTY PATENTS, COPYRIGHTS, TRADE SECRETS OR OTHER INTELLECTUAL PROPERTY RIGHTS.
 - 6.2 EXCEPT FOR THE LIMITED RIGHT TO USE THE EVM SET FORTH HEREIN, NOTHING IN THESE TERMS SHALL BE CONSTRUED AS GRANTING OR CONFERRING ANY RIGHTS BY LICENSE, PATENT, OR ANY OTHER INDUSTRIAL OR INTELLECTUAL PROPERTY RIGHT OF TI, ITS SUPPLIERS/LICENSORS OR ANY OTHER THIRD PARTY, TO USE THE EVM IN ANY FINISHED END-USER OR READY-TO-USE FINAL PRODUCT, OR FOR ANY INVENTION, DISCOVERY OR IMPROVEMENT, REGARDLESS OF WHEN MADE, CONCEIVED OR ACQUIRED.
 7. *USER'S INDEMNITY OBLIGATIONS AND REPRESENTATIONS.* USER WILL DEFEND, INDEMNIFY AND HOLD TI, ITS LICENSORS AND THEIR REPRESENTATIVES HARMLESS FROM AND AGAINST ANY AND ALL CLAIMS, DAMAGES, LOSSES, EXPENSES, COSTS AND LIABILITIES (COLLECTIVELY, "CLAIMS") ARISING OUT OF OR IN CONNECTION WITH ANY HANDLING OR USE OF THE EVM THAT IS NOT IN ACCORDANCE WITH THESE TERMS. THIS OBLIGATION SHALL APPLY WHETHER CLAIMS ARISE UNDER STATUTE, REGULATION, OR THE LAW OF TORT, CONTRACT OR ANY OTHER LEGAL THEORY, AND EVEN IF THE EVM FAILS TO PERFORM AS DESCRIBED OR EXPECTED.

8. *Limitations on Damages and Liability:*

8.1 *General Limitations.* IN NO EVENT SHALL TI BE LIABLE FOR ANY SPECIAL, COLLATERAL, INDIRECT, PUNITIVE, INCIDENTAL, CONSEQUENTIAL, OR EXEMPLARY DAMAGES IN CONNECTION WITH OR ARISING OUT OF THESE TERMS OR THE USE OF THE EVMS , REGARDLESS OF WHETHER TI HAS BEEN ADVISED OF THE POSSIBILITY OF SUCH DAMAGES. EXCLUDED DAMAGES INCLUDE, BUT ARE NOT LIMITED TO, COST OF REMOVAL OR REINSTALLATION, ANCILLARY COSTS TO THE PROCUREMENT OF SUBSTITUTE GOODS OR SERVICES, RETESTING, OUTSIDE COMPUTER TIME, LABOR COSTS, LOSS OF GOODWILL, LOSS OF PROFITS, LOSS OF SAVINGS, LOSS OF USE, LOSS OF DATA, OR BUSINESS INTERRUPTION. NO CLAIM, SUIT OR ACTION SHALL BE BROUGHT AGAINST TI MORE THAN TWELVE (12) MONTHS AFTER THE EVENT THAT GAVE RISE TO THE CAUSE OF ACTION HAS OCCURRED.

8.2 *Specific Limitations.* IN NO EVENT SHALL TI'S AGGREGATE LIABILITY FROM ANY USE OF AN EVM PROVIDED HEREUNDER, INCLUDING FROM ANY WARRANTY, INDEMNITY OR OTHER OBLIGATION ARISING OUT OF OR IN CONNECTION WITH THESE TERMS, , EXCEED THE TOTAL AMOUNT PAID TO TI BY USER FOR THE PARTICULAR EVM(S) AT ISSUE DURING THE PRIOR TWELVE (12) MONTHS WITH RESPECT TO WHICH LOSSES OR DAMAGES ARE CLAIMED. THE EXISTENCE OF MORE THAN ONE CLAIM SHALL NOT ENLARGE OR EXTEND THIS LIMIT.

9. *Return Policy.* Except as otherwise provided, TI does not offer any refunds, returns, or exchanges. Furthermore, no return of EVM(s) will be accepted if the package has been opened and no return of the EVM(s) will be accepted if they are damaged or otherwise not in a resalable condition. If User feels it has been incorrectly charged for the EVM(s) it ordered or that delivery violates the applicable order, User should contact TI. All refunds will be made in full within thirty (30) working days from the return of the components(s), excluding any postage or packaging costs.

10. *Governing Law:* These terms and conditions shall be governed by and interpreted in accordance with the laws of the State of Texas, without reference to conflict-of-laws principles. User agrees that non-exclusive jurisdiction for any dispute arising out of or relating to these terms and conditions lies within courts located in the State of Texas and consents to venue in Dallas County, Texas. Notwithstanding the foregoing, any judgment may be enforced in any United States or foreign court, and TI may seek injunctive relief in any United States or foreign court.

Mailing Address: Texas Instruments, Post Office Box 655303, Dallas, Texas 75265
Copyright © 2023, Texas Instruments Incorporated

IMPORTANT NOTICE AND DISCLAIMER

TI PROVIDES TECHNICAL AND RELIABILITY DATA (INCLUDING DATASHEETS), DESIGN RESOURCES (INCLUDING REFERENCE DESIGNS), APPLICATION OR OTHER DESIGN ADVICE, WEB TOOLS, SAFETY INFORMATION, AND OTHER RESOURCES "AS IS" AND WITH ALL FAULTS, AND DISCLAIMS ALL WARRANTIES, EXPRESS AND IMPLIED, INCLUDING WITHOUT LIMITATION ANY IMPLIED WARRANTIES OF MERCHANTABILITY, FITNESS FOR A PARTICULAR PURPOSE OR NON-INFRINGEMENT OF THIRD PARTY INTELLECTUAL PROPERTY RIGHTS.

These resources are intended for skilled developers designing with TI products. You are solely responsible for (1) selecting the appropriate TI products for your application, (2) designing, validating and testing your application, and (3) ensuring your application meets applicable standards, and any other safety, security, regulatory or other requirements.

These resources are subject to change without notice. TI grants you permission to use these resources only for development of an application that uses the TI products described in the resource. Other reproduction and display of these resources is prohibited. No license is granted to any other TI intellectual property right or to any third party intellectual property right. TI disclaims responsibility for, and you fully indemnify TI and its representatives against any claims, damages, costs, losses, and liabilities arising out of your use of these resources.

TI's products are provided subject to [TI's Terms of Sale](#), [TI's General Quality Guidelines](#), or other applicable terms available either on ti.com or provided in conjunction with such TI products. TI's provision of these resources does not expand or otherwise alter TI's applicable warranties or warranty disclaimers for TI products. Unless TI explicitly designates a product as custom or customer-specified, TI products are standard, catalog, general purpose devices.

TI objects to and rejects any additional or different terms you may propose.

Copyright © 2026, Texas Instruments Incorporated

Last updated 10/2025