

UCC276x4: Enabling Higher Efficiency in a Smaller Package



Jeremiah Vo and Sam Wallace

The UCC276x4 devices are a family of high-current, low-side drivers designed primarily to drive MOSFETs and IGBTs in both automotive and industrial applications. The family includes both the single channel UCC27614 and dual channel UCC27624 and UCC27624V. Some of the benefits are discussed below:

Power Density: The UCC276x4 family features high drive current, up to 10A, to reduce switching losses and improve overall system efficiency. This combined with the small SON package options for both the dual and single channel versions makes the UCC276x4 family one of the most power dense gate drivers available.

Robustness: The UCC276x4 family has a 30V max V_{DD} and the –10V negative voltage handling enables excellent noise and transient handling without the need for external components such as clamp diodes on the inputs and outputs.

Flexibility: The UCC276x4 family of devices come in a multitude of common industry packages to fit design engineers' preferences and requirements. Package differences include thermal package options or even leadless options.

Table 1. Product Summary

Product Features	Product Benefits	Key Applications
Up to 10A Drive Strength	Enables higher efficiency systems	<ul style="list-style-type: none">• Server Power• HEV/EV OBC + DC/DC• EV Charging• Micro-Inverter• Factory Automation• E-compressor• Data Center
30V Max V _{DD}	An excellent choice for handling transients and noise in operation	
–10V Negative Voltage Handling		
4V or 8V UVLO Options	Fit for MosFET, GaN FET, or IGBT applications	
2mm × 2mm Package (UCC27614) Option	High power density	
10ns Minimum Input Pulse	1MHz+ operation	

Target End Equipments

The UCC276x4 family of devices can be used in many end equipments. Consider how the product features can improve a system design.

Table 2. The UCC276x4 Helps Improve Your System

Product Characteristic	System Improvement
Size	2mm × 2mm packages enable small board size.
Robustness	30V VDD and -10V negative voltage handling allows the UCC276x4 to better withstand noise and transients
Cost	The excellent transient performance reduces the need for external components such as clamp diodes.
	Using the UCC27624 with a pulse transformer eliminates the need for a bias supply.
Efficiency	4V UVLO allows for use with 5V power rail reducing overall power loss.
	The 5A/10A output current helps reduce switching losses.
	High drive current and low rise and fall times enable switching above 1MHz.
Flexibility	UVLO, channel count, and package options help keep your system optimized.

Figure 1 through Figure 3 help explore some of the most popular use cases and respective topologies.

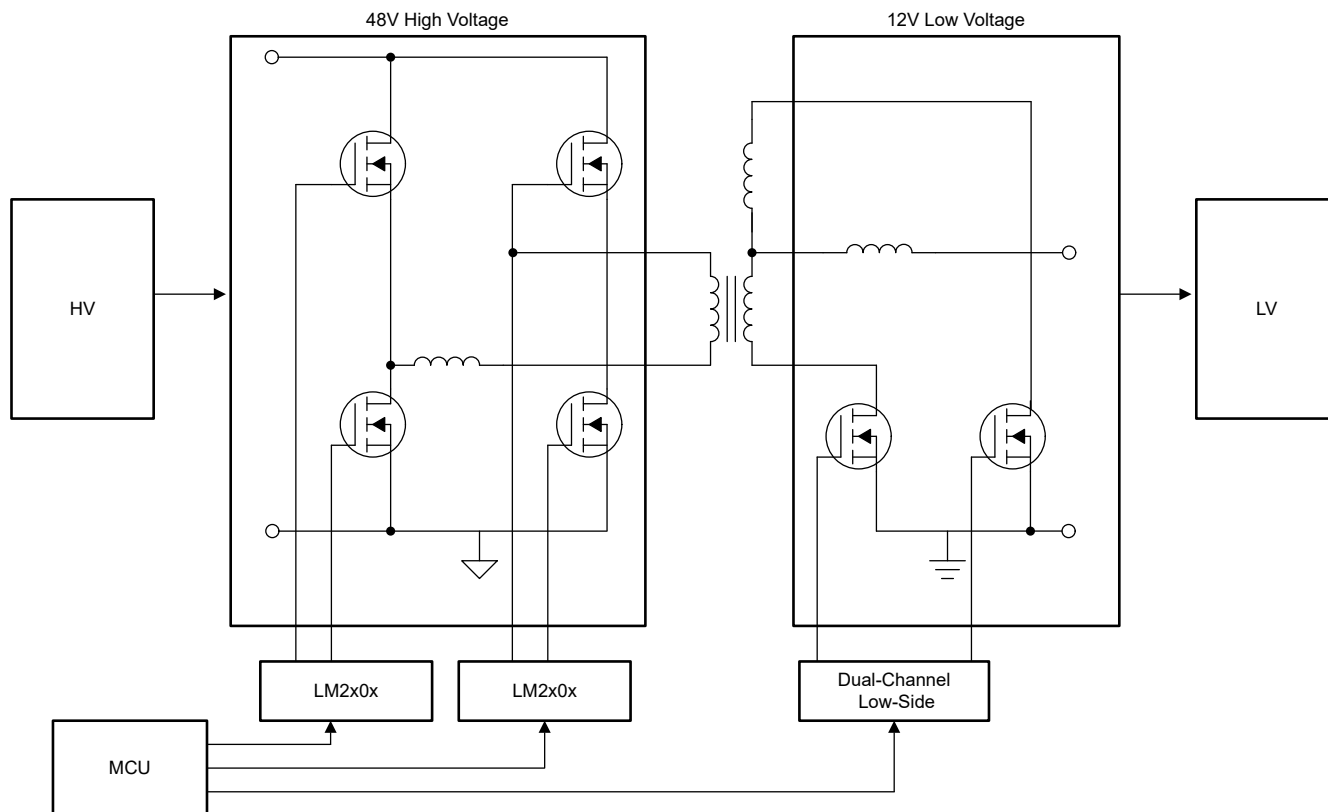

Figure 1. UCC27624-Q1 in HEV-EV DC-DC

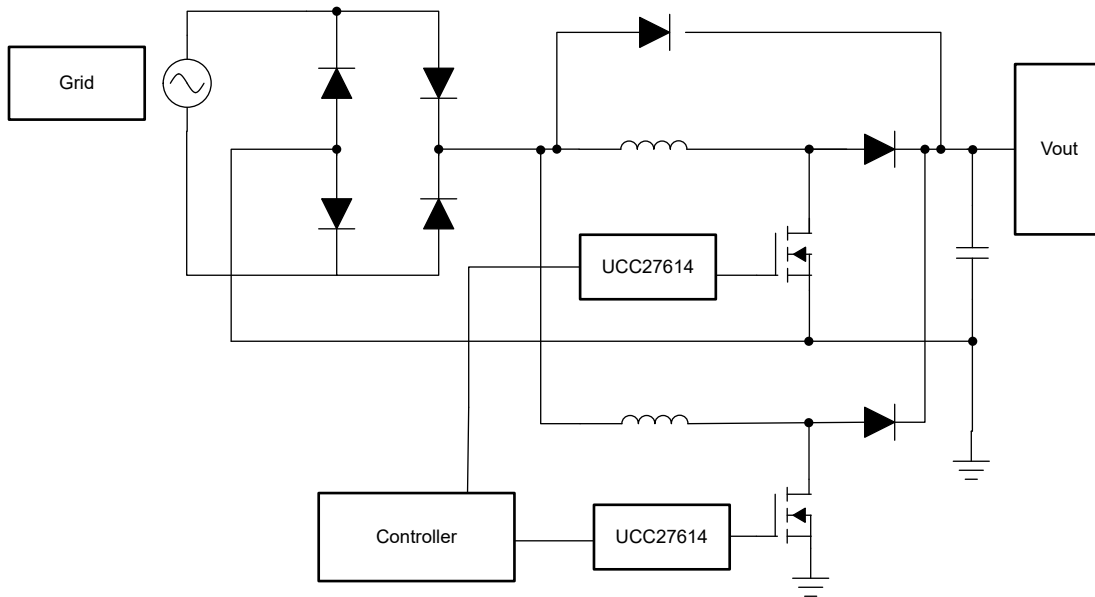

Figure 2. UCC27614 in Server Power Using Interleaved Boost PFC

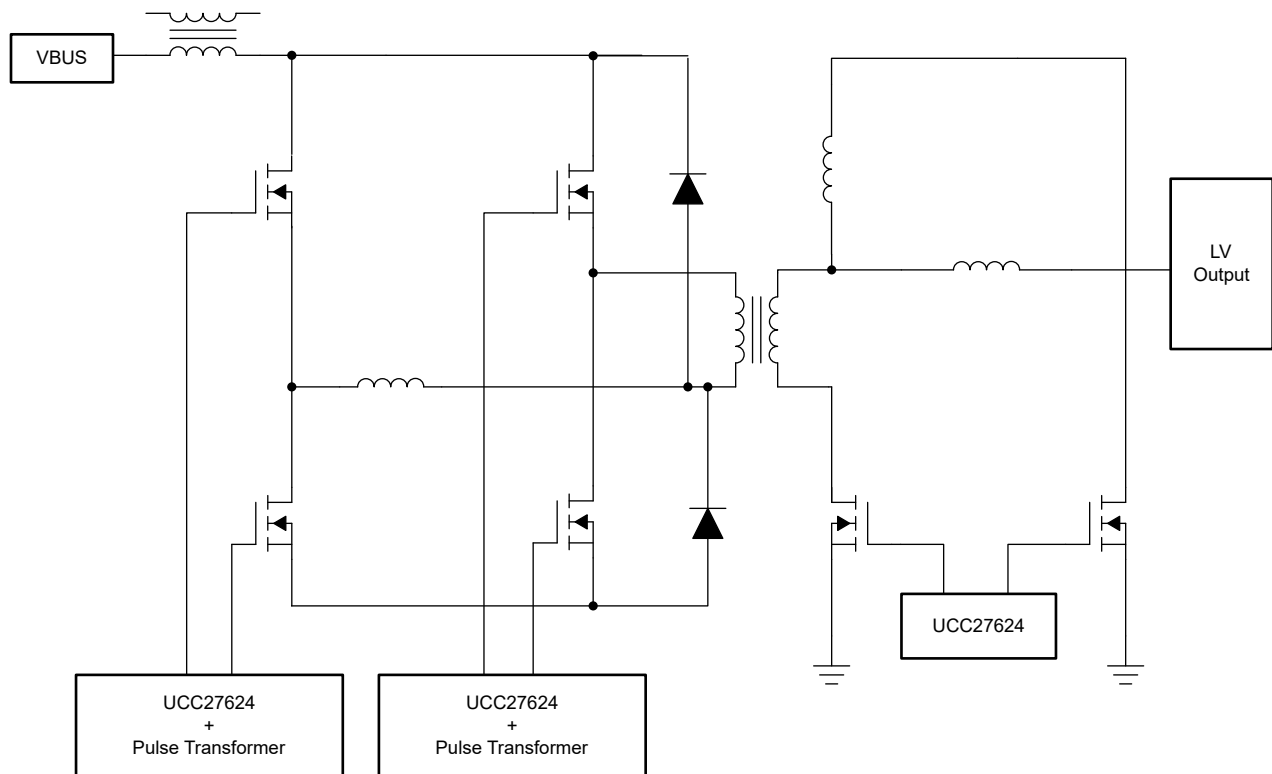

Figure 3. UCC27624 in EV Charging Using Phase-Shifted Full Bridge Driven by Pulse Transformers

Device Selection Guide

The UCC276x4 devices have distinct features, electrical specifications, and pinouts. To aid in selection, [Table 3](#) through [Table 6](#) help distinguish major differences between part numbers and variants, as well as provide insight to how these compare to legacy offerings.

Table 3. Device Selection Guide

Part Number	Channel Count	Gate Drive Output(Sink-Source)	UVLO	Package Options
UCC27614 (-Q1)	1	10A–10A	4V	D, DGN, DSG
UCC27624 (-Q1)	2	5A–5A	4V	D, DGN, DSD, DGK, DDA
UCC27624V (-Q1)	2	5A–5A	8V	D, DGN, DGK, DDA

Table 4. Pinout Maps for UCC27614

		
D 4.9mm × 3.9mm SOIC-8	DSG 2mm × 2mm WSON-8	DGN 3mm × 3mm HVSSOP-8

Table 5. Pinout Maps for UCC27624 and UCC27624V



				
D 4.9mm × 3.9mm SOIC-8	DGN 3mm × 3mm HVSSOP-8	DSD 3mm × 3mm WSON-8	DDA 4.9mm × 3.9mm HSOIC-8	DGK 3mm × 3mm VSSOP-8

Table 6. Legacy Devices Similar to UCC276x4

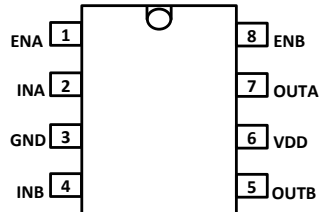
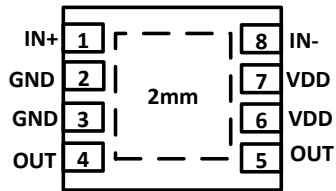
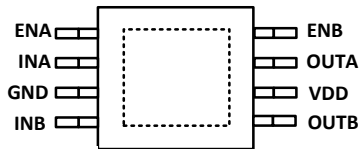
Legacy Device	New Replacement GPN	Pin-to-Pin	Key Advantages
UCC27524(A)	UCC27624	Yes	The improved VDD and negative voltage provides for improved transient and noise handling
UCC27424	UCC27624	Yes	The increased drive strength provides higher efficiency
UCC27322	UCC27614	Yes	The improved VDD and negative voltage provides for improved transient and noise handling
UCC27511(A)	UCC27614	No	Smaller package options allow for reduced design size

References

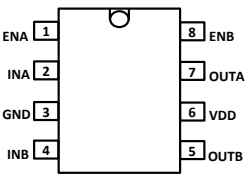
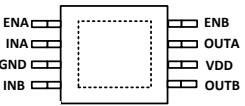
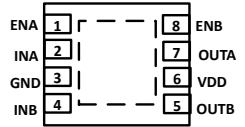
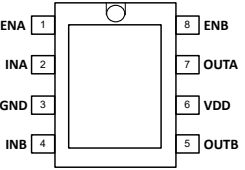
- Texas Instruments, [Managing power-supply noise with a 30V gate driver](#), technical article
- Texas Instruments, [Review of Different Power Factor Correction \(PFC\) Topologies' Gate Driver Needs](#), application note
- Texas Instruments, [Selecting Gate Drivers for HVAC Systems](#) application note
- Texas Instruments, [UCC27614](#), product page
- Texas Instruments, [UCC27614-Q1](#), product page
- Texas Instruments, [UCC27624](#), product page
- Texas Instruments, [UCC27624-Q1](#), product page
- Texas Instruments, [UCC27624V](#), product page
- Texas Instruments, [UCC27624V-Q1](#), product page
- Texas Instruments, [Why use a Gate Drive Transformer?](#), application note

Additional Information

Table 7. Orderable Table

Orderable Device	Package Type	Pins	Op Temp (°C)	Device Marking
UCC27624DGNR	HVSSOP	8	-40 to 150	U624
UCC27624DR	SOIC	8	-40 to 150	U27624
UCC27624DSDR	SON	8	-40 to 150	624DSD
UCC27624DGKR	VSSOP	8	-40 to 150	24DK
UCC27624DDAR	SO PowerPAD™	8	-40 to 150	U624DDA
UCC27624QDGNRQ1	HVSSOP	8	-40 to 150	624Q
UCC27624QDRQ1	SOIC	8	-40 to 150	27624Q
UCC27624QSDRQ1	SON	8	-40 to 150	624QSD
UCC27624QDGKRQ1	VSSOP	8	-40 to 150	24QK
UCC27624QDDARQ1	SO PowerPAD	8	-40 to 150	U624QDDA
UCC27624VDGNR	HVSSOP	8	-40 to 150	624V
UCC27624VDR	SOIC	8	-40 to 150	27624V
UCC27624VDGKR	VSSOP	8	-40 to 150	JVDK
UCC27624VDDAR	SO PowerPAD	8	-40 to 150	U624VDDA
UCC27624VQDGNRQ1	HVSSOP	8	-40 to 150	24VQ
UCC27624VQDRQ1	SOIC	8	-40 to 150	U624VQ
UCC27624VQDGKRQ1	VSSOP	8	-40 to 150	JVQK
UCC27624VQDDARQ1	SO PowerPAD	8	-40 to 150	624VQDDA
UCC27614DR	SOIC	8	-40 to 150	U27614
UCC27614DSGR	WSON	8	-40 to 150	U614
UCC27614QDGNRQ1	HVSSOP	8	-40 to 150	614Q
UCC27614QDRQ1	SOIC	8	-40 to 150	27614Q
UCC27614QDSGRQ1	WSON	8	-40 to 150	614Q

Trademarks

PowerPAD™ is a trademark of Texas Instruments.
All trademarks are the property of their respective owners.

IMPORTANT NOTICE AND DISCLAIMER

TI PROVIDES TECHNICAL AND RELIABILITY DATA (INCLUDING DATASHEETS), DESIGN RESOURCES (INCLUDING REFERENCE DESIGNS), APPLICATION OR OTHER DESIGN ADVICE, WEB TOOLS, SAFETY INFORMATION, AND OTHER RESOURCES "AS IS" AND WITH ALL FAULTS, AND DISCLAIMS ALL WARRANTIES, EXPRESS AND IMPLIED, INCLUDING WITHOUT LIMITATION ANY IMPLIED WARRANTIES OF MERCHANTABILITY, FITNESS FOR A PARTICULAR PURPOSE OR NON-INFRINGEMENT OF THIRD PARTY INTELLECTUAL PROPERTY RIGHTS.

These resources are intended for skilled developers designing with TI products. You are solely responsible for (1) selecting the appropriate TI products for your application, (2) designing, validating and testing your application, and (3) ensuring your application meets applicable standards, and any other safety, security, regulatory or other requirements.

These resources are subject to change without notice. TI grants you permission to use these resources only for development of an application that uses the TI products described in the resource. Other reproduction and display of these resources is prohibited. No license is granted to any other TI intellectual property right or to any third party intellectual property right. TI disclaims responsibility for, and you fully indemnify TI and its representatives against any claims, damages, costs, losses, and liabilities arising out of your use of these resources.

TI's products are provided subject to [TI's Terms of Sale](#), [TI's General Quality Guidelines](#), or other applicable terms available either on [ti.com](#) or provided in conjunction with such TI products. TI's provision of these resources does not expand or otherwise alter TI's applicable warranties or warranty disclaimers for TI products. Unless TI explicitly designates a product as custom or customer-specified, TI products are standard, catalog, general purpose devices.

TI objects to and rejects any additional or different terms you may propose.

Copyright © 2026, Texas Instruments Incorporated

Last updated 10/2025