

Taiwo Arojoye

Introduction

High-precision, motion and sensing systems increasingly rely on compact, high-accuracy signal chains to capture position, current, or optical power information. These constraints show up across a wide range of applications such as rotary and linear encoders, robotics, compact servo drives, galvanometer scanners, optical modules such as EDFAs, and other space constrained industrial designs. In many of these systems, the front-end must digitize low distortion, differential signals such as sine/cosine position waveforms, photodiode transimpedance outputs, or current sense feedback. Precision ADCs paired with fully differential amplifiers (FDAs) are commonly used to acquire these signals while maintaining low noise, high linearity and minimal board area.

The [ADS9327](#) is a 16-bit, 5-MSPS, 2-Ch, Simultaneously Sampling, SAR ADC that introduces an integrated common-mode voltage (VCM) buffer. This capability improves performance, reduces design complexity and design size.

Importance of a Stable Common-Mode Voltage

A stable VCM ensures that these signals remain within the linear operating region of the analog front-end, maintain their intended shape, and provide noise immunity. The VCM must also match the input requirements of the ADC to maximize dynamic range. For most SAR ADCs, this VCM must be precisely centered, low-noise, and low-impedance. Without an integrated buffer, designers must generate this VCM externally using op-amps or dedicated buffers which adds cost, board area, and potential error sources.

ADS9327 Internal Common-Mode Voltage Buffer

The ADS9327 integrates a low-noise, low-impedance common-mode buffer that directly drives the fully differential amplifier. This eliminates the need for an external VCM driver and provides several system-level advantages. Traditionally, engineers design the VCM output given to the amplifier as half of the reference voltage, but in a single supply design, a VCM of half the reference voltage can result in the signal coming close to the negative rail of the amplifier, which can result in distortion. The ADS9327, at default settings, provides a VCM closer to 2.24V, which keeps the signal away from the negative rail of the amplifier. The VCM output can be configured to eight different values ranging from 2.04V to 2.49V. This flexibility verifies full ADC swing capability while maintaining performance integrity.

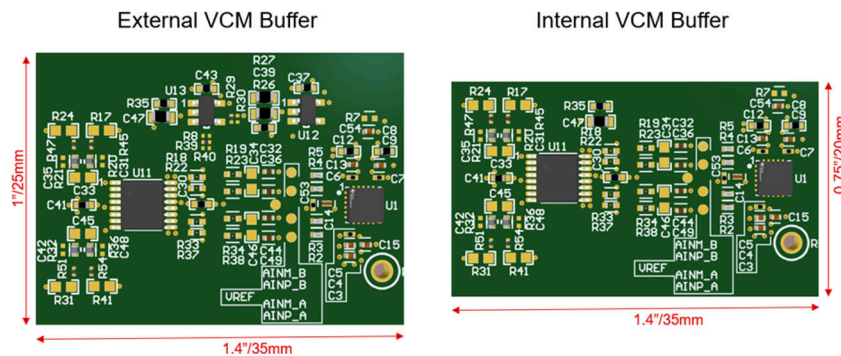

Figure 1. External vs Internal Common-Mode Voltage Buffer

Figure 1 compares the size difference between two signal chains where one is using the internal VCM buffer of the ADS9327 and the other is not. The PCB on the left uses two units of the OPA320 as external buffers. One OPA320 is used as a reference buffer and voltage divider while the other one is used as VCM buffer for the fully differential amplifier which results in the PCB size being 875mm². Using the internal VCM buffer of the ADS9327 removes the need for the OPA320 and reduces the design size by 20%. Figure 2 shows the schematic for the PCBs and Table 1 lists the register mapping for the VCM. The CH A section captures the ADS9327 and the THS4552 required for the internal VCM buffer design while the VCM section captures the additional OPA320 buffers for the PCB with the external VCM buffer design.

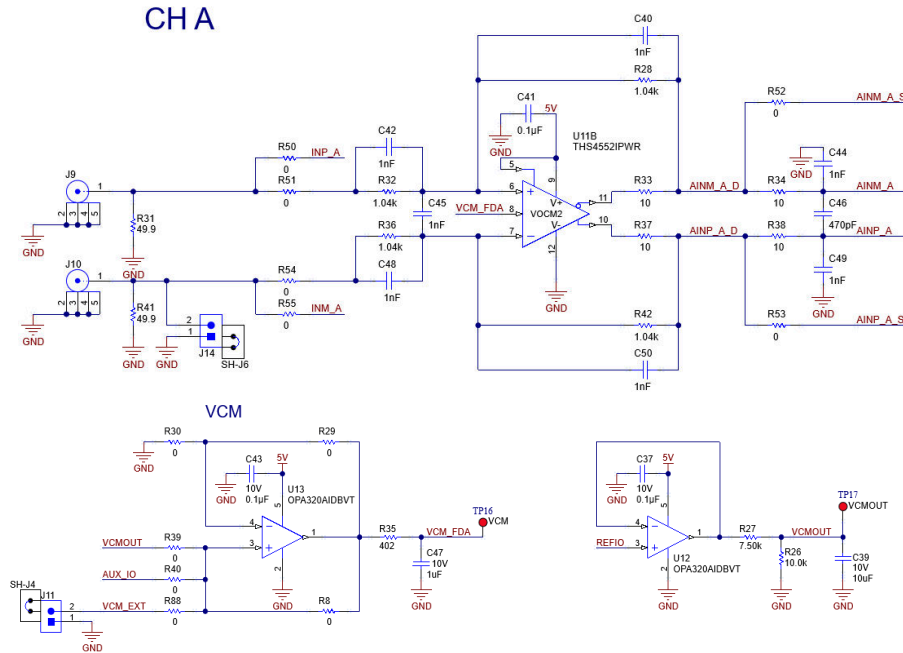

Figure 2. Signal Chain Schematic

Table 1. VCM Register Mapping

VCM_Sel<2:0>	VCM_Meas
0	2.23
1	2.17
2	2.11
3	2.04
4	2.49
5	2.43
6	2.36
7	2.29

Conclusion

For engineers designing compact, high-accuracy signal chains, the ADS9327 offers a compelling combination of precision, simplicity, and robustness. The integrated common-mode voltage buffer removes a traditional pain point in these signal chains, reducing design complexity while improving performance. This makes the ADS9327 family an excellent fit for modern high-precision motion and sensing systems where precision, size, and reliability are essential.

Related Articles

- Texas Instruments, [Precision ADCs in Servo Drives](#), application brief.
- Texas Instruments, [Precision ADCs for Motor Encoders and Position Sensing](#), product overview.
- Texas Instruments, [Encoder Signal Chain](#), application brief.
- Texas Instruments, [Position Feedback: Capturing 1VPP Sin or Cos Encoder Signals With a Simultaneous-Sampling SAR ADC](#), application brief.
- Texas Instruments, [1MHz Signal-Chain for Wide Bandwidth Data Acquisition](#), application brief.
- Texas Instruments, [Interface to Sin/Cos Encoders with High-Resolution Position Interpolation](#), reference design.

Trademarks

All trademarks are the property of their respective owners.

IMPORTANT NOTICE AND DISCLAIMER

TI PROVIDES TECHNICAL AND RELIABILITY DATA (INCLUDING DATASHEETS), DESIGN RESOURCES (INCLUDING REFERENCE DESIGNS), APPLICATION OR OTHER DESIGN ADVICE, WEB TOOLS, SAFETY INFORMATION, AND OTHER RESOURCES "AS IS" AND WITH ALL FAULTS, AND DISCLAIMS ALL WARRANTIES, EXPRESS AND IMPLIED, INCLUDING WITHOUT LIMITATION ANY IMPLIED WARRANTIES OF MERCHANTABILITY, FITNESS FOR A PARTICULAR PURPOSE OR NON-INFRINGEMENT OF THIRD PARTY INTELLECTUAL PROPERTY RIGHTS.

These resources are intended for skilled developers designing with TI products. You are solely responsible for (1) selecting the appropriate TI products for your application, (2) designing, validating and testing your application, and (3) ensuring your application meets applicable standards, and any other safety, security, regulatory or other requirements.

These resources are subject to change without notice. TI grants you permission to use these resources only for development of an application that uses the TI products described in the resource. Other reproduction and display of these resources is prohibited. No license is granted to any other TI intellectual property right or to any third party intellectual property right. TI disclaims responsibility for, and you fully indemnify TI and its representatives against any claims, damages, costs, losses, and liabilities arising out of your use of these resources.

TI's products are provided subject to [TI's Terms of Sale](#), [TI's General Quality Guidelines](#), or other applicable terms available either on ti.com or provided in conjunction with such TI products. TI's provision of these resources does not expand or otherwise alter TI's applicable warranties or warranty disclaimers for TI products. Unless TI explicitly designates a product as custom or customer-specified, TI products are standard, catalog, general purpose devices.

TI objects to and rejects any additional or different terms you may propose.

Copyright © 2026, Texas Instruments Incorporated

Last updated 10/2025