

Sitara AM62A-Q1, AM62P-Q1, and AM62D-Q1 Power-Supply Design Using the TPS6522430-Q1 and TPS6522230-Q1



Description

The TPS6522x-Q1 PMIC provides compact multi-rail power delivery for Sitara AM62A, AM62P, and AM62D processors. The device integrates four high-efficiency buck converters and three configurable low-dropout regulators in a 5mm × 6mm package. The PMIC supports up to 10A dual-phase operation, includes power sequencing logic, and meets ASIL-B functional safety requirements for automotive applications.

Resources

TIPA-050071	Design Folder
TPS6522430-Q1	Product Folder
TPS6522230-Q1	Product Folder
TPS65224-Q1	Product Folder
TPS65222-Q1	Product Folder

Features

- 12-bit ADC, watchdog, error signal monitoring
- Integrated power management
- Functional safety ASIL-B support
- Power sequencing logic
- Comprehensive protection
- Voltage telemetry
- Space efficiency

Applications

- [ADAS domain controller](#)
- [Mirror replacement/camera mirror system](#)
- [Telematics control unit](#)



[Ask the TI E2E™ support experts](#)

1 System Description

This design guide shows the design considerations for implementing the TPS6522x-Q1 PMIC in compact systems. The PMIC targets systems that require safe and cost-effective multi-rail power delivery. Applications include digital clusters, driver monitoring systems, camera mirrors and industrial vision modules. Embedded processors such as the Sitara™ and Jacinto™ processors become increasingly central to ADAS and infotainment platforms. Power approaches must scale with performance demands while staying within strict size constraints. The approaches must also meet thermal and reliability constraints.

The [TPS65222-Q1](#) and [TPS65224-Q1](#) address these challenges by integrating four high-efficiency buck converters into a single 5mm × 6mm package. The device also integrates three configurable low-dropout regulators. The PMIC supports 5.5A single and dual phase buck operation up to 10A. The device can power high-performance SoCs while reducing board space and BOM complexity. The PMIC also includes integrated power sequencing logic and GPIO-configurable PDN profiles. This design allows for reuse across multiple system configurations with minimal hardware changes. For variants that include an internal 12-bit ADC, *such as the TPS65224-Q1*, voltage telemetry enables in-system monitoring. The monitoring covers critical rails for diagnostic and safety verification.

Functional safety is central to the TPS6522x-Q1 design, which developers created in accordance with ISO26262. The PMIC meets ASIL-B hardware integrity requirements and includes built-in protections. The protections include an integrated watchdog, over- and undervoltage monitoring, thermal shutdown, and error signal management.

2 System Overview

2.1 Block Diagram

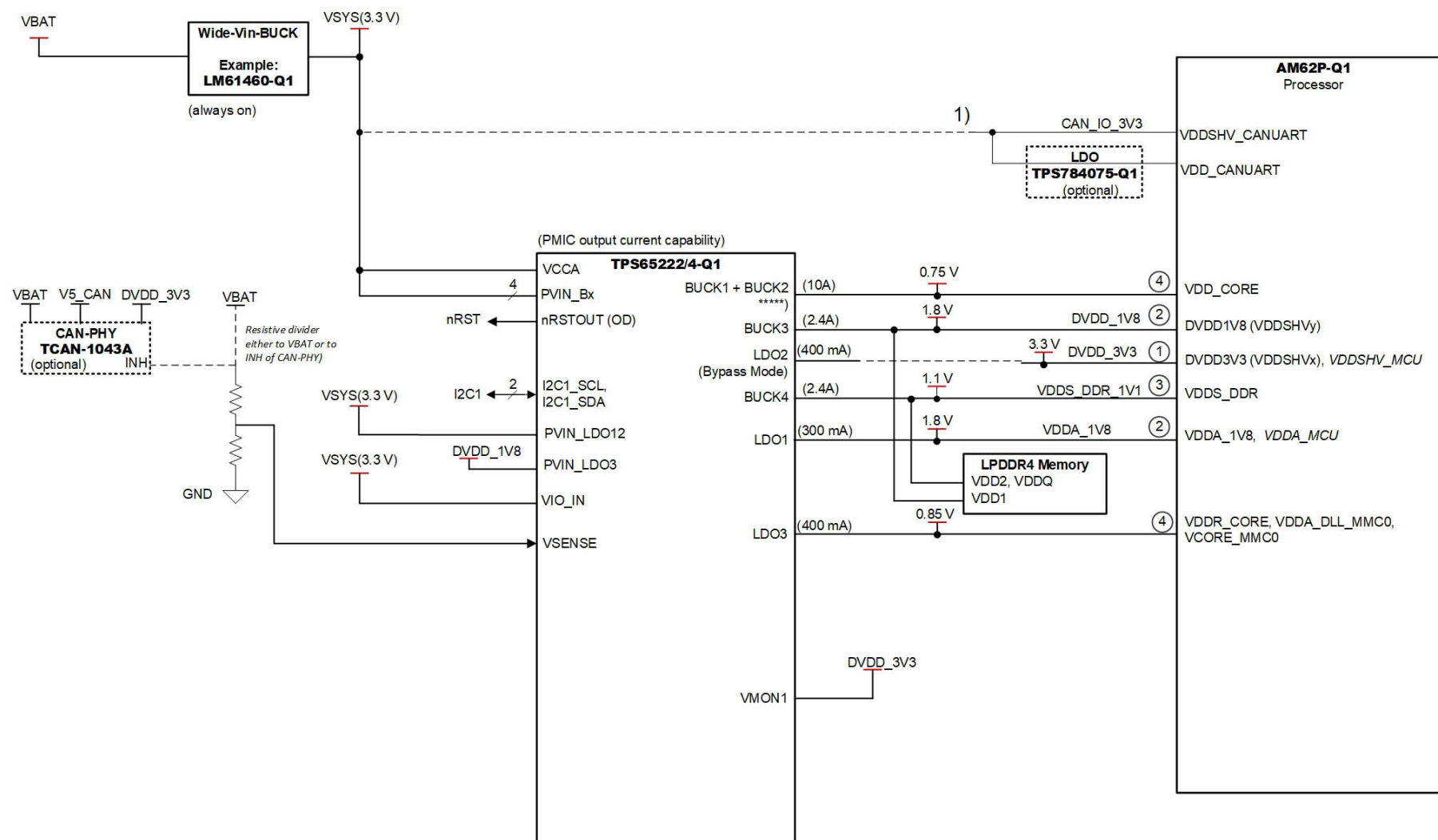

Figure 2-1. Block Diagram

Optional components are available for integration. Certain use cases can require these to achieve full functionality.

For a more detailed power design user's guide and supported use cases, request access at the following link: <https://www.ti.com/drr/opn/TPS6522X-DESIGN-RESOURCES>.

2.2 Highlighted Products

2.2.1 TPS6522x30-Q1

[Table 2-1](#) lists three different variants that have the same functionality but slightly different features. This document references all these devices as TPS6522x30-Q1.

Table 2-1. Device Versions

GENERIC PART NUMBER (GPN)	ORDERABLE PART NUMBER	ADC	PACKAGE
TPS65224-Q1	TPS6522430RAHRQ1	Yes	Non-Wettable Flank
	TPS6522430WRAHRQ1	Yes	Wettable Flank
TPS65222-Q1	TPS6522230WRAHRQ1	No	Wettable Flank

3 Design and Documentation Support

3.1 Documentation Support

1. Texas Instruments, [TPS65222-Q1 Power Management IC \(PMIC\) with 4 BUCKs and 3 LDOs for Safety-Relevant Applications](#) datasheet
2. Texas Instruments, [TPS65224-Q1 Power Management IC \(PMIC\) with 4 BUCKs and 3 LDOs for Safety-Relevant Applications](#) datasheet

3.2 Support Resources

[TI E2E™ support forums](#) are an engineer's go-to source for fast, verified answers and design help — straight from the experts. Search existing answers or ask your own question to get the quick design help you need.

Linked content is provided "AS IS" by the respective contributors. They do not constitute TI specifications and do not necessarily reflect TI's views; see TI's [Terms of Use](#).

3.3 Trademarks

E2E™, Sitara™, Jacinto™, and TI E2E™ are trademarks of Texas Instruments. All trademarks are the property of their respective owners.

4 Revision History

NOTE: Page numbers for previous revisions may differ from page numbers in the current version.

Changes from Revision * (July 2025) to Revision A (June 2026)	Page
• Updated the document title.	1
• Updated the document format to a design guide.	1
• Added Description , Features , and Applications topics.	1
• Added the Design and Documentation Support section.....	5

IMPORTANT NOTICE AND DISCLAIMER

TI PROVIDES TECHNICAL AND RELIABILITY DATA (INCLUDING DATASHEETS), DESIGN RESOURCES (INCLUDING REFERENCE DESIGNS), APPLICATION OR OTHER DESIGN ADVICE, WEB TOOLS, SAFETY INFORMATION, AND OTHER RESOURCES "AS IS" AND WITH ALL FAULTS, AND DISCLAIMS ALL WARRANTIES, EXPRESS AND IMPLIED, INCLUDING WITHOUT LIMITATION ANY IMPLIED WARRANTIES OF MERCHANTABILITY, FITNESS FOR A PARTICULAR PURPOSE OR NON-INFRINGEMENT OF THIRD PARTY INTELLECTUAL PROPERTY RIGHTS.

These resources are intended for skilled developers designing with TI products. You are solely responsible for (1) selecting the appropriate TI products for your application, (2) designing, validating and testing your application, and (3) ensuring your application meets applicable standards, and any other safety, security, regulatory or other requirements.

These resources are subject to change without notice. TI grants you permission to use these resources only for development of an application that uses the TI products described in the resource. Other reproduction and display of these resources is prohibited. No license is granted to any other TI intellectual property right or to any third party intellectual property right. TI disclaims responsibility for, and you fully indemnify TI and its representatives against any claims, damages, costs, losses, and liabilities arising out of your use of these resources.

TI's products are provided subject to [TI's Terms of Sale](#), [TI's General Quality Guidelines](#), or other applicable terms available either on [ti.com](#) or provided in conjunction with such TI products. TI's provision of these resources does not expand or otherwise alter TI's applicable warranties or warranty disclaimers for TI products. Unless TI explicitly designates a product as custom or customer-specified, TI products are standard, catalog, general purpose devices.

TI objects to and rejects any additional or different terms you may propose.

Copyright © 2026, Texas Instruments Incorporated

Last updated 10/2025