

## MSPM0C1105, MSPM0C1106 Mixed-Signal Microcontrollers

### 1 Features

- **Core**
  - Arm® 32-bit Cortex®-M0+ CPU with memory protection unit, frequency up to 32MHz
- **Operating characteristics**
  - Extended temperature: –40°C up to 125°C
  - Wide supply voltage range: 1.62V to 3.6V
- **Memories**
  - Up to 64KB of flash memory
  - 8KB of SRAM
- **High-performance analog peripherals**
  - 12-bit 1.6 Msps analog-to-digital converter (ADC), up to 27 external channels
  - Configurable 1.4V or 2.5V internal shared voltage reference (VREF)
  - Comparator (COMP) with 8-bit reference DAC
  - Integrated temperature sensor
- **Optimized low-power modes**
  - RUN: 91µA/MHz (CoreMark)
  - STANDBY 2µA and SRAM and registers fully retained
  - SHUTDOWN: 68nA with I/O wake-up
- **Intelligent digital peripherals**
  - 3-channel DMA controller
  - 7-channel event fabric signaling system
  - Five timers supporting up to 18 PWM outputs, all operational down to STANDBY mode
    - One 16-bit advanced timer with deadband and the timer frequency up to 64Mhz
    - One 16-bit general purpose timer with 4 capture/compares
    - Three 16-bit general-purpose timers with 2 capture/compares
  - Window-watchdog timer (WWDT)
  - Independent watchdog timer (IWDT)
  - RTC with alarm and calendar mode
  - BEEPER generating 1/2/4/8kHz square wave to drive an external beeper
- **Communication interfaces**
  - Three UART modules, with one supporting LIN, IrDA, DALI, smart card, Manchester
  - Two I<sup>2</sup>C modules supporting SMBus/PMBus and wakeup from STOP mode, supporting up to FM+ (1Mbps)
  - One SPI module supporting up to 16Mbps
- **Clock system**
  - Internal 32MHz oscillator with -2.1% to 1.6% accuracy (SYSOSC)
  - Internal 32kHz oscillator (LFOSC) with ±3% accuracy
  - External 4MHz to 32MHz crystal oscillator (HFXT)
  - External 32kHz crystal oscillator (LFXT)
  - External Low Frequency (LF) and High Frequency (HF) digital clock inputs
  - Digital clock output
- **Data integrity and encryption**
  - Cyclic redundancy checker (CRC-16)
- **Flexible I/O features**
  - Up to 45 total GPIOs
  - Two 5V-tolerant open-drain IOs
- **Development support**
  - 2-pin serial wire debug (SWD)
- **Package options**<sup>1</sup>
  - 48-pin LQFP (PT), VQFN (RGZ), NFBGA (ZCM)
  - 32-pin LQFP (VFC), VQFN (RHB)
  - 28-pin VSSOP (DGS28)
  - 24-pin VQFN (RGE)
  - 20-pin WQFN (RUK), VSSOP (DGS20)
- **Family members** (also see [Device Comparison](#))
  - MSPM0C1106: 64KB of flash, 8KB of RAM
  - MSPM0C1105: 32KB of flash, 8KB of RAM
  - MSP32G031C8: 64KB of flash, 8KB of RAM
  - MSP32G031C6: 32KB of flash, 8KB of RAM
  - MSP32C031C6: 32KB of flash, 8KB of RAM
- **Development kits and software** (also see [Tools and Software](#))
  - LP-MSPM0C1106 LaunchPad™ development kit
  - MSP Software Development Kit (SDK)

### 2 Applications

- [Battery charging and management](#)
- [Power supplies and power delivery](#)
- [Personal electronics](#)
- [Building security and fire safety](#)
- [Connected peripherals and printers](#)
- [Grid infrastructure](#)
- [Smart metering](#)
- [Communication modules](#)
- [Medical and healthcare](#)
- [Lighting](#)

<sup>1</sup> 32-pin LQFP (VFC) is preview



### 3 Description

MSPM0C1105/6 microcontrollers (MCUs) are part of MSP's highly integrated, ultra-low-power [32-bit MSPM0 MCU family](#) based on the Arm® Cortex®-M0+ 32-bit core platform, operating at up to 32MHz frequency. These cost-optimized MCUs offer high-performance analog peripheral integration, support extended temperature ranges from -40°C to 125°C, and operate with supply voltages from 1.62V to 3.6V.

The MSPM0C1105/6 devices provide up to 64KB embedded flash program memory with 8KB SRAM. These MCUs incorporate a high-speed on-chip oscillator with an accuracy from -2.1% to +1.6%, eliminating the need for an external crystal. Additional features include a 3-channel DMA, CRC-16 accelerator, and a variety of high-performance analog peripherals such as one 12-bit 1.6 Msp/s ADC with VDD as the voltage reference, a comparator with 8-bit reference DAC and an on-chip temperature sensor. These devices also offer intelligent digital peripherals such as one 16-bit advanced timer with deadband and timer frequency up to 64MHz, four 16-bit general purpose timer, one windowed watchdog timer, and a variety of communication peripherals including three UART, one SPI, and two I2C. These communication peripherals offer protocol support for LIN, IrDA, DALI, Manchester, smart card, SMBus, and PMBus.

The TI MSPM0 family of low-power MCUs consists of devices with varying degrees of analog and digital integration allowing for customers to find the MCU that meets the project's needs. The MSPM0 MCU platform combines the Arm Cortex-M0+ platform with a holistic ultra-low-power system architecture, allowing system designers to increase performance while reducing energy consumption.

MSPM0C1105/6 MCUs are supported by an extensive hardware and software ecosystem with reference designs and code examples to get the design started quickly. Development kits include a [LaunchPad](#) available for purchase. TI also provides a free MSP Software Development Kit (SDK), which is available as a component of [Code Composer Studio™ IDE](#) desktop and cloud version within the [TI Resource Explorer](#). MSPM0 MCUs are also supported by extensive online collateral, training with [MSP Academy](#), and online support through the [TI E2E™ support forums](#).

For complete module descriptions, see the [MSPM0 C-Series Microcontrollers Technical Reference Manual](#).

**Table 3-1. Package Information**

PART NUMBER <sup>(1) (2)</sup>	PACKAGE	PACKAGE SIZE <sup>(3) (4)</sup>
MSPM0C1106SPTR	PT (LQFP, 48) <sup>(6)</sup>	9mm × 9mm
MSPM0C1105SPTR	PT (LQFP, 48) <sup>(6)</sup>	9mm × 9mm
MSPM0C1106SRGZR	RGZ (VQFN, 48)	7mm × 7mm
MSPM0C1105SRGZR	RGZ (VQFN, 48)	7mm × 7mm
MSPM0C1106SZCMR	ZCM (NFBGA, 48)	3.5mm × 3.5mm
MSPM0C1105SZCMR	ZCM (NFBGA, 48)	3.5mm × 3.5mm
MSPM0C1106SRHBR	RHB (VQFN, 32)	5mm × 5mm
MSPM0C1105SRHBR	RHB (VQFN, 32)	5mm × 5mm
MSPM0C1106SDGS28R	DGS28 (VSSOP, 28)	7.1mm × 4.9mm
MSPM0C1105SDGS28R	DGS28 (VSSOP, 28)	7.1mm × 4.9mm
MSPM0C1106SRGER	RGE (VQFN, 24)	4mm × 4mm
MSPM0C1105SRGER	RGE (VQFN, 24)	4mm × 4mm
MSPM0C1106SDGS20R	DGS20 (VSSOP, 20)	5.1mm × 4.9mm
MSPM0C1105SDGS20R	DGS20 (VSSOP, 20)	5.1mm × 4.9mm
MSPM0C1106SRUKR	RUK (WQFN, 20)	3mm × 3mm
MSPM0C1105SRUKR	RUK (WQFN, 20)	3mm × 3mm
MSP32C031C6SPTR	PT (LQFP, 48) <sup>(6)</sup>	9mm × 9mm
MSP32G031C6SPTR	PT (LQFP, 48) <sup>(6)</sup>	9mm × 9mm
MSP32G031C8SPTR	PT (LQFP, 48) <sup>(6)</sup>	9mm × 9mm
MSP32G031K6SVFCR	VFC (LQFP, 32) <sup>(5)</sup>	9mm × 9mm

**Table 3-1. Package Information (continued)**

PART NUMBER <sup>(1)</sup> <sup>(2)</sup>	PACKAGE	PACKAGE SIZE <sup>(3)</sup> <sup>(4)</sup>
MSP32C031K6SVFCR	VFC (LQFP, 32) <sup>(5)</sup>	9mm × 9mm
MSP32G031K8SVFCR	VFC (LQFP, 32) <sup>(5)</sup>	9mm × 9mm

- (1) For the most current part, package, and ordering information for all available devices, see the *Package Option Addendum*, or see the [TI website](#).
- (2) Please find more information about the device name in the *Device Nomenclature* section.
- (3) For more information, see [Mechanical, Packaging, and Orderable Information](#).
- (4) The package size (length × width) is a nominal value and includes pins, where applicable.
- (5) 32-pin LQFP (VFC) is preview.
- (6) There are two pin configurations for the PT (LQFP, 48) package. Refer to [Section 6.2](#) for more information.

**CAUTION**

System-level ESD protection must be applied in compliance with the device-level ESD specification to prevent electrical overstress or disturbing of data or code memory. See [MSP430™ System-Level ESD Considerations](#) for more information. The principles in this application note are applicable to MSPM0 MCUs.

## 4 Functional Block Diagram

Figure 4-1 shows the functional block diagram.

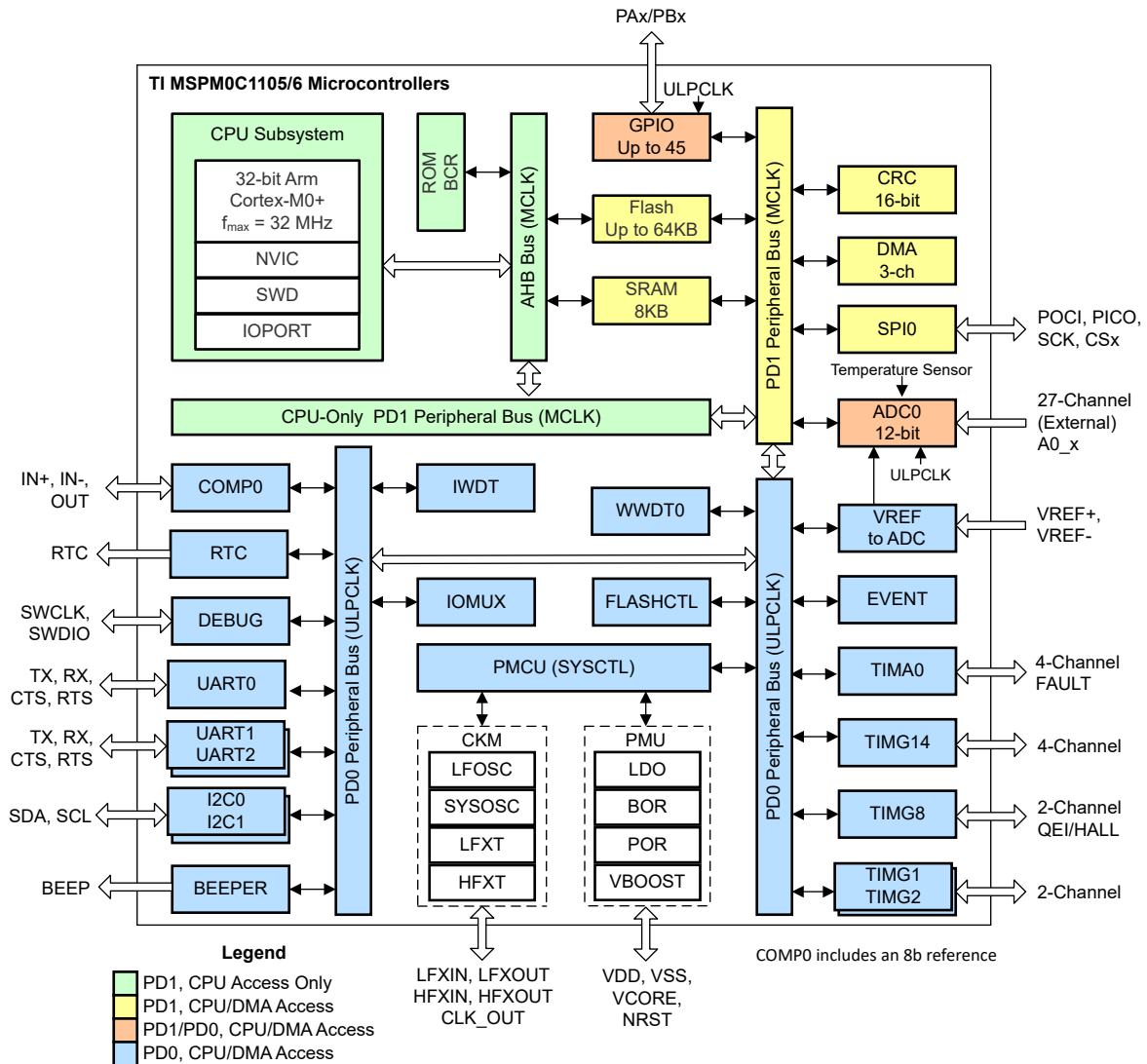

Figure 4-1. MSPM0C1105/6 Functional Block Diagram

## Table of Contents

<b>1 Features</b> .....	1	8.8 Memory.....	63
<b>2 Applications</b> .....	1	8.9 Flash Memory.....	66
<b>3 Description</b> .....	2	8.10 SRAM.....	66
<b>4 Functional Block Diagram</b> .....	4	8.11 GPIO.....	67
<b>5 Device Comparison</b> .....	6	8.12 IOMUX.....	67
<b>6 Pin Configuration and Functions</b> .....	7	8.13 ADC.....	67
6.1 Pin Diagrams.....	7	8.14 Temperature Sensor.....	68
6.2 Pin Attributes.....	14	8.15 Low-Frequency Sub System (LFSS).....	68
6.3 Signal Descriptions.....	28	8.16 VREF.....	68
6.4 Connections for Unused Pins.....	40	8.17 COMP.....	69
<b>7 Specifications</b> .....	41	8.18 Security.....	70
7.1 Absolute Maximum Ratings.....	41	8.19 CRC.....	70
7.2 ESD Ratings.....	41	8.20 UART.....	70
7.3 Recommended Operating Conditions.....	41	8.21 I2C.....	71
7.4 Thermal Information.....	42	8.22 SPI.....	71
7.5 Supply Current Characteristics.....	44	8.23 IWDG.....	71
7.6 Power Supply Sequencing.....	44	8.24 WWDT.....	72
7.7 Flash Memory Characteristics.....	46	8.25 RTC_B.....	72
7.8 Timing Characteristics.....	46	8.26 Timers (TIMx).....	73
7.9 Clock Specifications.....	47	8.27 Device Analog Connections.....	75
7.10 <i>Digital IO</i> .....	49	8.28 Input/Output Diagrams.....	76
7.11 Analog Mux VBOOST.....	50	8.29 Serial Wire Debug Interface.....	76
7.12 ADC.....	50	8.30 DEBUGSS.....	77
7.13 Temperature Sensor.....	52	8.31 Device Factory Constants.....	77
7.14 VREF.....	53	8.32 Identification.....	78
7.15 <i>Comparator (COMP)</i> .....	53	<b>9 Applications, Implementation, and Layout</b> .....	79
7.16 I2C.....	54	9.1 Typical Application.....	79
7.17 SPI.....	55	<b>10 Device and Documentation Support</b> .....	80
7.18 UART.....	57	10.1 Getting Started and Next Steps.....	80
7.19 TIMx.....	57	10.2 Device Nomenclature.....	80
7.20 Emulation and Debug.....	57	10.3 Tools and Software.....	81
<b>8 Detailed Description</b> .....	58	10.4 Documentation Support.....	81
8.1 Overview.....	59	10.5 Support Resources.....	82
8.2 CPU.....	59	10.6 Trademarks.....	82
8.3 Operating Modes.....	59	10.7 Electrostatic Discharge Caution.....	82
8.4 Power Management Unit (PMU).....	61	10.8 Glossary.....	82
8.5 Clock Module (CKM).....	61	<b>11 Revision History</b> .....	82
8.6 DMA_B.....	62	<b>12 Mechanical, Packaging, and Orderable Information</b> .....	83
8.7 Events.....	63		

## 5 Device Comparison

**Table 5-1. Device Comparison Table**

DEVICE NAME <sup>(1)</sup>	FLASH / SRAM (KB)	ADC CHANNEL	UART / I2C / SPI	TIMG	TIMA	GPIO	COMP	PACKAGE <sup>(2)</sup>
MSPM0C1106SPTR	64 / 8	27	3 / 2 / 1	4	1	45	1	48 LQFP (9mm × 9mm)
MSPM0C1105SPTR	32 / 8							
MSPM0C1106SRGZR	64 / 8	27	3 / 2 / 1	4	1	45	1	48 VQFN (7mm × 7mm)
MSPM0C1105SRGZR <sup>(3)</sup>	32 / 8							
MSPM0C1106SZCMR <sup>(3)</sup>	64 / 8	27	3 / 2 / 1	4	1	45	1	48 NFBGA (3.5mm × 3.5mm)
MSPM0C1105SZCMR <sup>(3)</sup>	32 / 8							
MSPM0C1106SRHBR	64 / 8	18	3 / 2 / 1	4	1	29	1	32 VQFN (5mm × 5mm)
MSPM0C1105SRHBR	32 / 8							
MSPM0C1106SDGS28R	64 / 8	15	3 / 2 / 1	4	1	25	1	28 VSSOP (7.1mm × 4.9mm)
MSPM0C1105SDGS28R	32 / 8							
MSPM0C1106SRGER	64 / 8	13	3 / 2 / 1	4	1	21	1	24 VQFN (4mm × 4mm)
MSPM0C1105SRGER	32 / 8							
MSPM0C1106SDGS20R	64 / 8	12	3 / 2 / 1	4	1	17	1	20 VSSOP (5.1mm × 4.9mm)
MSPM0C1105SDGS20R	32 / 8							
MSPM0C1106SRUKR	64 / 8	12	3 / 2 / 1	4	1	17	1	20 WQFN (3mm × 3mm)
MSPM0C1105SRUKR	32 / 8							
MSP32C031C6SPTR	32 / 8	27	3 / 2 / 1	4	1	45	1	48 LQFP (9mm × 9mm)
MSP32G031C6SPTR	32 / 8							
MSP32G031C8SPTR	64 / 8							
MSP32G031K6SVFCR <sup>(3)</sup>	32 / 8	18	3 / 2 / 1	4	1	29	1	32 LQFP (9mm × 9mm)
MSP32C031K6SVFCR <sup>(3)</sup>	32 / 8							
MSP32G031K8SVFCR <sup>(3)</sup>	64 / 8							

- (1) For the most current part, package, and ordering information for all available devices, see the *Package Option Addendum*, or see the [TI website](#).
- (2) The sizes shown here are approximations. For the package dimensions with tolerances, see the *Mechanical Data*.
- (3) 32-pin LQFP (VFC) and 48-pin NFBGA (ZCM) are preview

## 6 Pin Configuration and Functions

The [System Configuration tool](#) provides a graphical interface to enable, configurable, and generate initialization code for pin multiplexing and simplifying pin settings. The pin diagrams shown in the data sheet show the primary peripheral functions, some of the integrated device features, and available clock signals to simplify the device pinout.

For full descriptions of the pin functions, see the *Pin Attributes* and *Signal Descriptions* sections.

### 6.1 Pin Diagrams

#### Note

For full pin configuration and functions for each package option, refer to [Pin Attributes](#) and [Signal Descriptions](#).

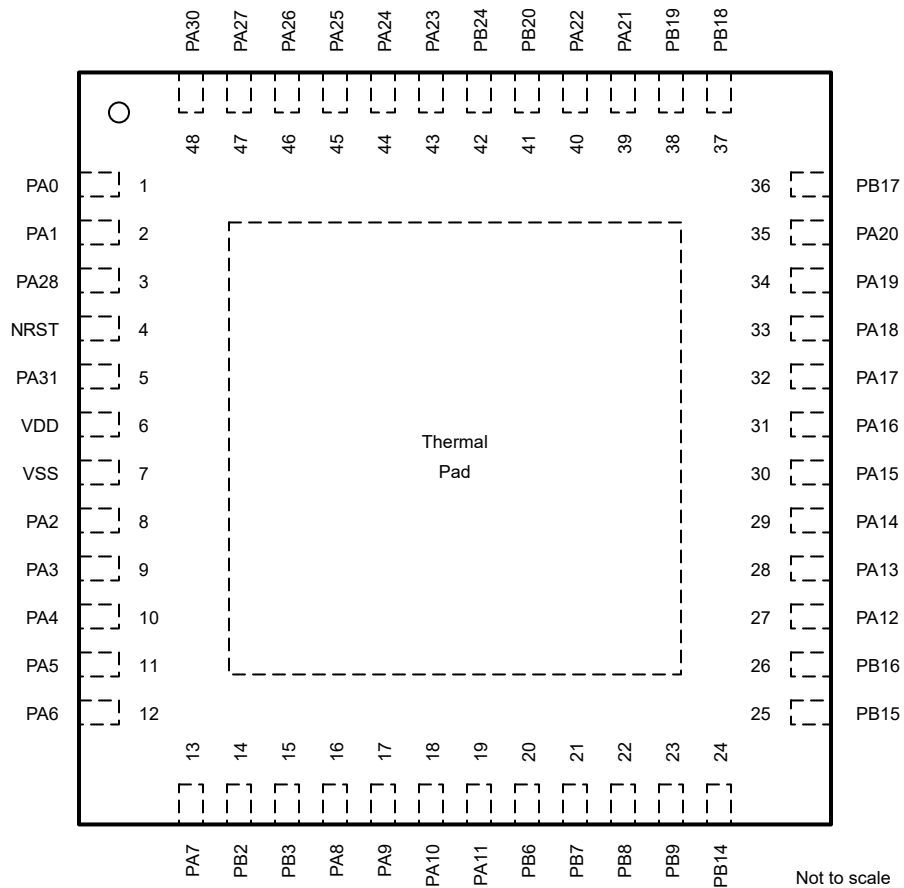

**Figure 6-1. 48-pin RGZ (VQFN) Package**

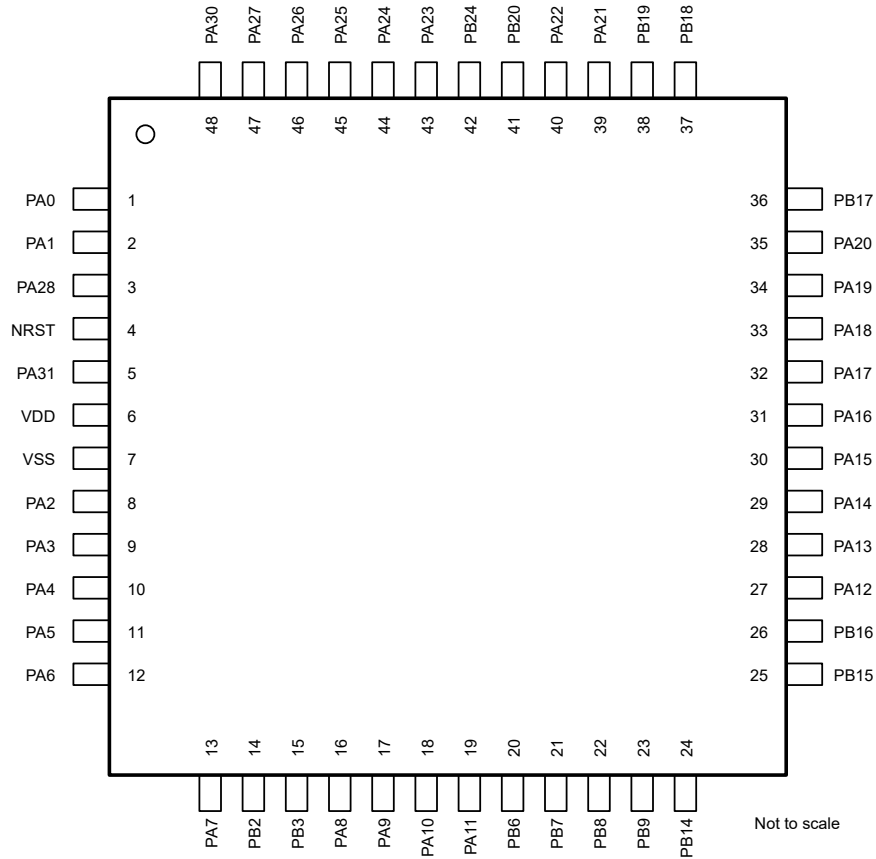

**Figure 6-2. 48-pin PT (A) 48-pin PT (LQFP) Package**

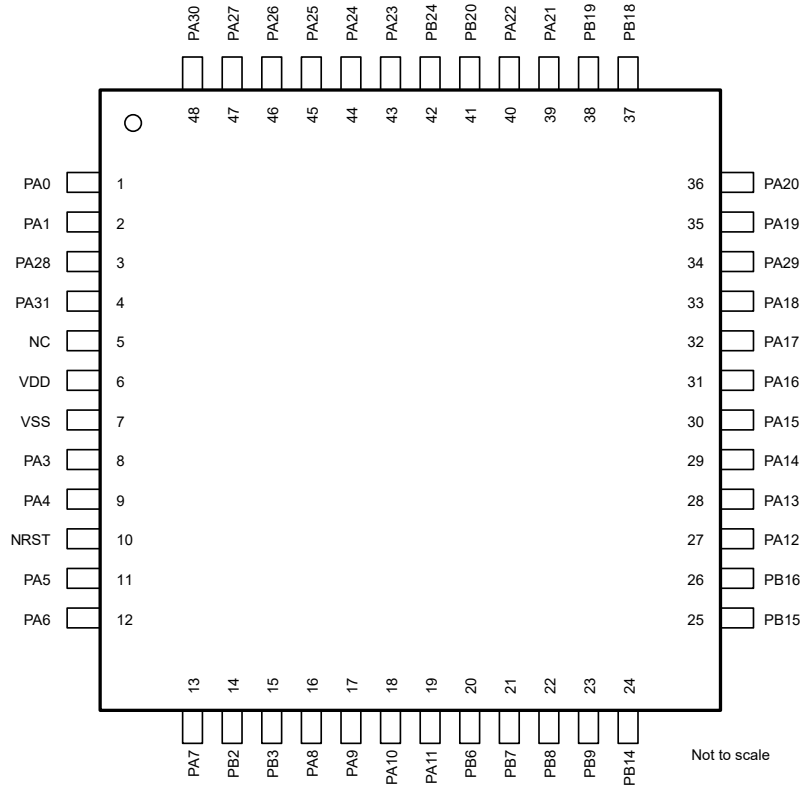

**Figure 6-3. 48-pin PT (B) (LQFP) Package**

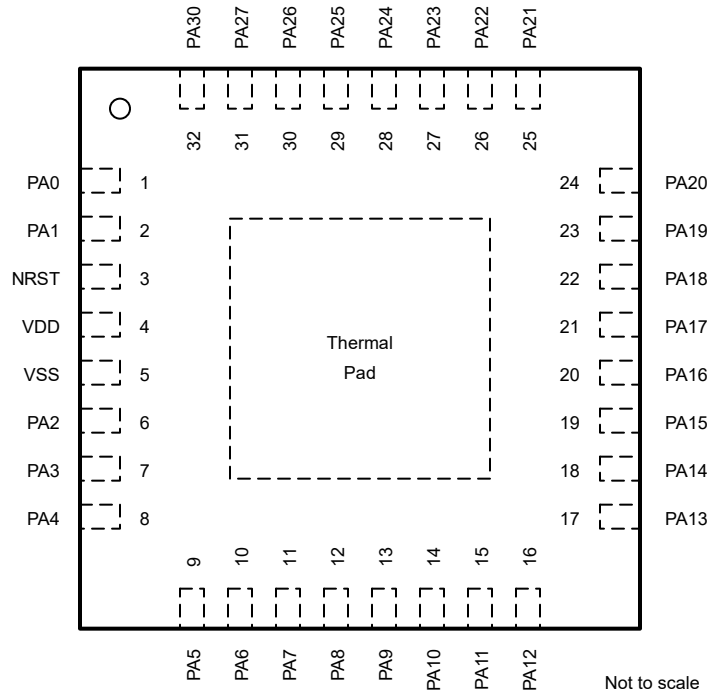

**Figure 6-4. 32-pin RHB (VQFN) Package**

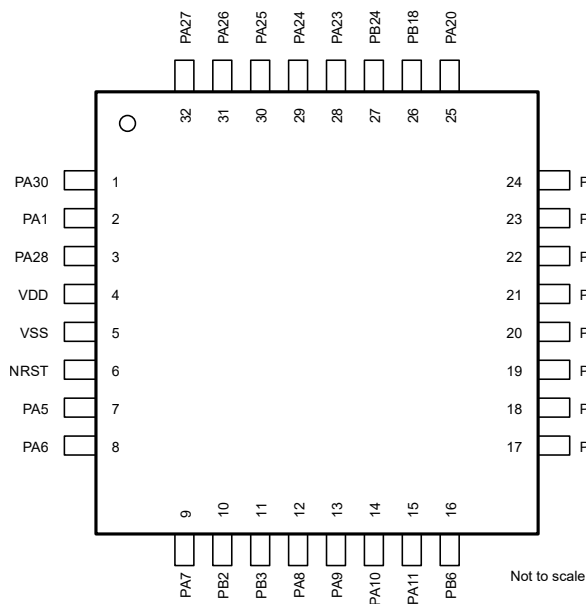

**Figure 6-5. 32-pin VFC (LQFP)**

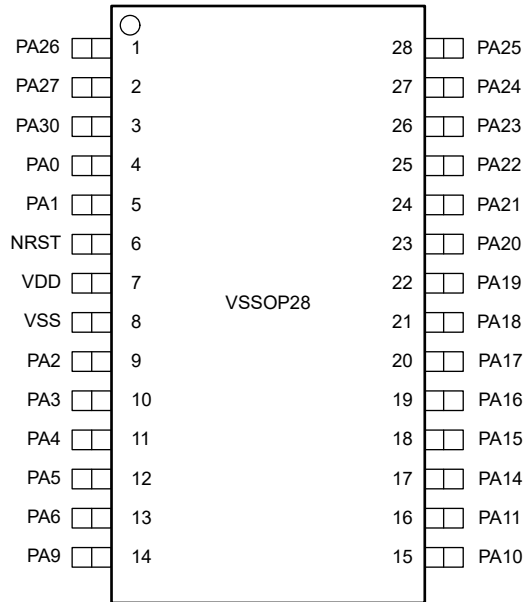

**Figure 6-6. 28-pin DGS28 (VSSOP)**

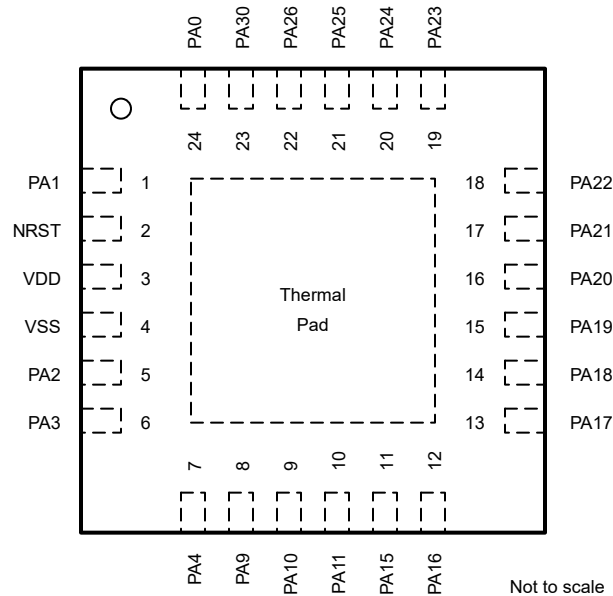

**Figure 6-7. 24-pin RGE (VQFN) Package**

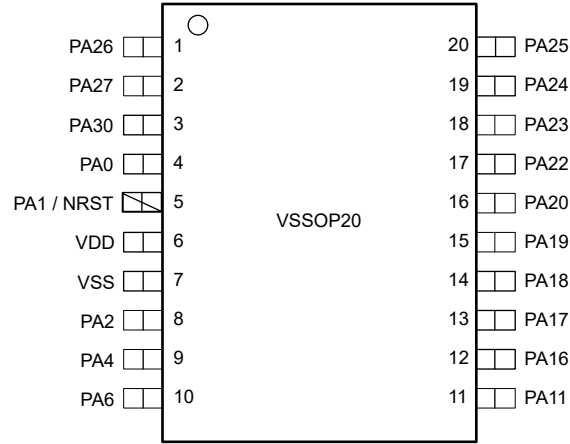

**Figure 6-8. 20-pin DGS20 (VSSOP)**

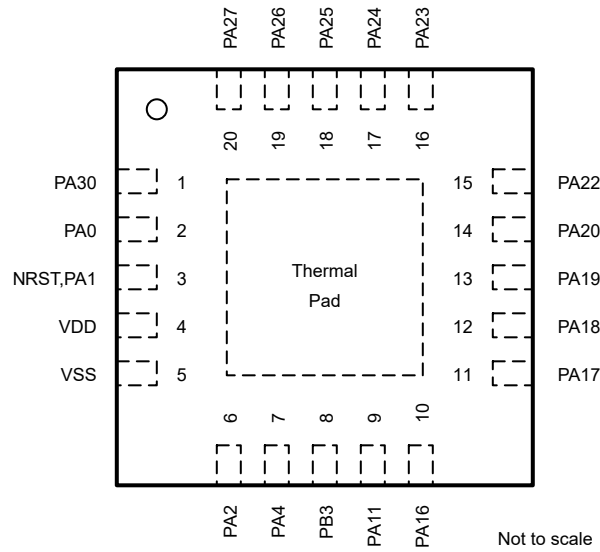

**Figure 6-9. 20-pin RUK (WQFN)**

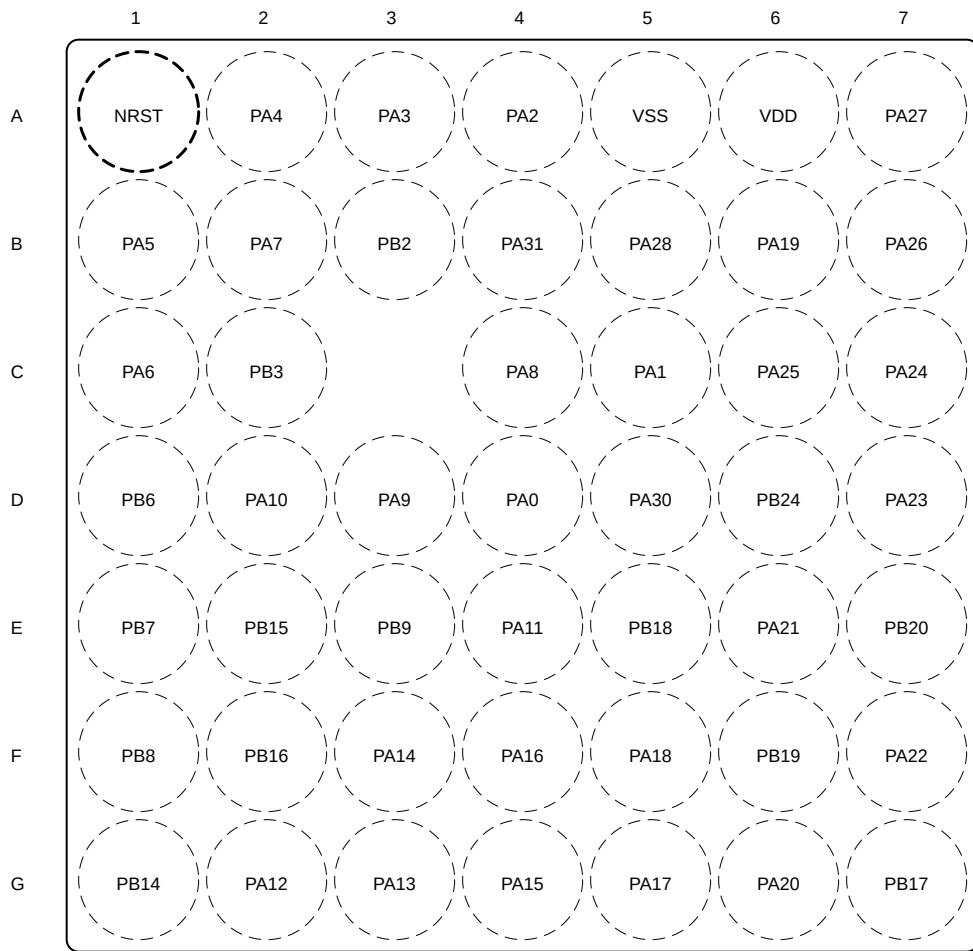

Not to scale

**Figure 6-10. 48-pin ZCM (NFBGA) Package (Top view)**

## 6.2 Pin Attributes

The following table describes the functions available on every pin for each device package.

### Note

Each digital I/O on a device is mapped to a specific Pin Control Management Register (PINCMx) that lets users configure the desired *Pin Function* using the PINCM.PF control bits.

Each digital I/O on a device is mapped to a specific Pin Control Management Register (PINCMx) which allows users to configure the desired Pin Function using the PINCM.PF control bits. The IOMUX only supports connecting one IOMUX-managed digital function to the pin at the same time. The PINCM.PF and PINCM.PC in IOMUX are recommended to be set to 0 when non-IOMUX managed functions (such as analog connections) are intended to be used on a pin. However, non-IOMUX managed signals (such as analog inputs and WAKE inputs) can be enabled on a pin at the same time that an IOMUX managed digital function is enabled on the pin, provided there is no contention between the functions. In this case, the designer must verify that no contention exists between the functions enabled on each pin.

**Table 6-1. Digital IO Features by IO Type**

BUFFER TYPE	INVERSION CONTROL	DRIVE STRENGTH CONTROL	HYSTERESIS CONTROL	PULLUP RESISTOR	PULLDOWN RESISTOR	WAKEUP LOGIC
SDIO (standard drive)	Y			Y	Y	
SDIO (standard drive) with wake <sup>1</sup>	Y			Y	Y	Y
ODIO (5V-tolerant open drain)	Y		Y		Y	Y

- Standard with Wake allows the I/O to wake up the device from the lowest low-power mode of SHUTDOWN. All I/O can be configured to wakeup the MCU from higher low-power modes. See section *GPIO FastWake* in the [MSPM0 C-Series Microcontrollers Technical Reference Manual](#) for details.

### Note

There are two pin configurations for the 48 LQFP (PT) package denoted as PT (A) and PT (B). The following devices correspond to these respective configurations:

- PT (A): MSPM0C1105SPTR, & MSPM0C1106SPTR
- PT (B): MSP32C031C6SPTR, MSP32G031C6SPTR, & MSP32G031C8SPTR

**Table 6-2. Pin Attributes (PT (A), ZCM, VFC, PT (B), RGZ, RHB, DGS28, RGE, DGS20, RUK Packages)**

PT (A) PIN	ZCM PIN	VFC PIN	PT (B) PIN	RGZ PIN	RHB PIN	DGS28 PIN	RGE PIN	DGS20 PIN	RUK PIN	PIN NAME/ IOMUX REG/ IOMUX ADDR	SIGNAL NAME	IOMUX PF	SIGNAL TYPE	BUFFER TYPE
4	A1	6	10	4	3	6	2	5	3	NRST	NRST	(Non-IOMUX 1) 0	RESET	RESET
1	D4		1	1	1	4	24	4	2	PA0 PINCM1 0x40428000	PA0	1	IO	ODIO (5V- tol)with wake
											UART0_TX	2	O	
											I2C0_SDA	3	IOD	
											TIMA0_C0	4	IO	
											TIMA_FALL1	5	I	
											FCC_IN	6	I	
											TIMG8_C1	7	IO	
											BEEP	8	O	
											TIMG14_C0	9	IO	
											SPI0_CS1_MISO1	10	IO	
RTC_OUT	12	O												

**Table 6-2. Pin Attributes (PT (A), ZCM, VFC, PT (B), RGZ, RHB, DGS28, RGE, DGS20, RUK Packages)**  
(continued)

PT (A) PIN	ZCM PIN	VFC PIN	PT (B) PIN	RGZ PIN	RHB PIN	DGS28 PIN	RGE PIN	DGS20 PIN	RUK PIN	PIN NAME/ IOMUX REG/ IOMUX ADDR	SIGNAL NAME	IOMUX PF	SIGNAL TYPE	BUFFER TYPE
2	C5	2	2	2	2	5	1	5	3	PA1 PINCM2 0x40428004	PA1	1	IO	ODIO (5V- tol)with wake
											UART0_RX	2	IO	
											I2C0_SCL	3	IOD	
											TIMA0_C1	4	IO	
											TIMA_FALL2	5	I	
											TIMG8_IDX	6	I	
											TIMG8_C0	7	IO	
											TIMG14_C1	9	IO	
											SPI0_CS3_CD_MISO3	10	IO	
											HFCLKIN	11	I	
											UART0_TX	12	O	
											UART1_RTS	13	O	
											I2C0_SDA	14	IOD	
											8	A4		
TIMG8_C1	2	IO												
SPI0_CS0	3	IO												
TIMG2_C1	4	IO												
TIMG8_IDX	5	I												
TIMA0_C3N	6	O												
TIMA0_C2N	7	O												
TIMA_FALL0	8	I												
TIMA_FALL1	9	I												
TIMA0_C0	11	IO												
I2C0_SCL	12	IOD												
9	A3		8	9	7	10	6		PA3 PINCM6 0x40428014	PA3				1
										TIMG8_C0	2	IO		
										SPI0_CS1_MISO1	3	IO		
										I2C1_SDA	4	IOD		
										TIMA0_C1	5	IO		
										TIMG2_C0	7	IO		
										TIMA0_C2	8	IO		
										UART2_CTS	9	I		
										UART1_TX	10	O		
										SPI0_CS3_CD_MISO3	11	IO		
										I2C0_SDA	12	IOD		
										COMP0_OUT	14	O		
										LFXIN	(Non-IOMUX 1) 0	A		

**Table 6-2. Pin Attributes (PT (A), ZCM, VFC, PT (B), RGZ, RHB, DGS28, RGE, DGS20, RUK Packages)  
(continued)**

PT (A) PIN	ZCM PIN	VFC PIN	PT (B) PIN	RGZ PIN	RHB PIN	DGS28 PIN	RGE PIN	DGS20 PIN	RUK PIN	PIN NAME/ IOMUX REG/ IOMUX ADDR	SIGNAL NAME	IOMUX PF	SIGNAL TYPE	BUFFER TYPE
10	A2		9	10	8	11	7	9	7	PA4 PINCM7 0x40428018	PA4	1	IO	SDIO (standar d)
											TIMG8_C1	2	IO	
											SPI0_POCI	3	IO	
											I2C1_SCL	4	IOD	
											TIMA0_C1N	5	O	
											LFCLKIN	6	I	
											TIMG2_C1	7	IO	
											TIMA0_C3	8	IO	
											UART2_RTS	9	O	
											UART1_RX	10	I	
											SPI0_CS0	11	IO	
											TIMA0_C0N	12	O	
											HFCLKIN	13	I	
LFXOUT	(Non-IOMUX 1) 0	A												
11	B1	7	11	11	9	12				PA5 PINCM8 0x4042801c	PA5	1	IO	SDIO (standar d)
											TIMG8_C0	2	IO	
											SPI0_PICO	3	IO	
											I2C1_SDA	4	IOD	
											TIMG14_C0	5	IO	
											FCC_IN	6	I	
											TIMG1_C0	7	IO	
											TIMA_FALL1	8	I	
											UART0_CTS	9	I	
											UART1_TX	11	O	
											TIMA0_C1	12	IO	
											HFXIN	(Non-IOMUX 1) 0	A	
12	C1	8	12	12	10	13		10		PA6 PINCM9 0x40428020	PA6	1	IO	SDIO (standar d)
											TIMG8_C1	2	IO	
											SPI0_SCLK	3	IOD	
											I2C1_SCL	4	IOD	
											TIMG14_C1	5	IO	
											HFCLKIN	6	I	
											TIMG1_C1	7	IO	
											TIMA_FALL0	8	I	
											UART0_RTS	9	O	
											TIMA0_C2N	10	O	
											UART1_RX	11	I	
											TIMA0_C2	12	IO	
											I2C0_SDA	13	IOD	
											BEEP	14	O	
HFXOUT	(Non-IOMUX 1) 0	A												

**Table 6-2. Pin Attributes (PT (A), ZCM, VFC, PT (B), RGZ, RHB, DGS28, RGE, DGS20, RUK Packages)**  
(continued)

PT (A) PIN	ZCM PIN	VFC PIN	PT (B) PIN	RGZ PIN	RHB PIN	DGS28 PIN	RGE PIN	DGS20 PIN	RUK PIN	PIN NAME/ IOMUX REG/ IOMUX ADDR	SIGNAL NAME	IOMUX PF	SIGNAL TYPE	BUFFER TYPE
13	B2	9	13	13	11					PA7 PINCM10 0x40428024	PA7	1	IO	SDIO (standar d)
											CLK_OUT	2	O	
											TIMG8_C0	3	IO	
											TIMA0_C2	4	IO	
											TIMG8_IDX	5	I	
											TIMG2_C1	6	IO	
											TIMA0_C1	7	IO	
											SPI0_CS2_MIS O2	8	IO	
											FCC_IN	9	I	
											SPI0_POCI	10	IO	
											SPI0_PICO	11	IO	
											UART1_TX	12	O	
											TIMG1_C0	13	IO	
											COMP0_OUT	14	O	
16	C4	12	16	16	12					PA8 PINCM13 0x40428030	PA8	1	IO	SDIO (standar d)
											UART1_TX	2	O	
											SPI0_CS0	3	IO	
											I2C0_SDA	4	IOD	
											TIMA0_C0	5	IO	
											TIMA_FAL2	6	I	
											TIMA_FAL0	7	I	
											SPI0_CS3_CD _MISO3	8	IO	
											TIMG2_C1	9	IO	
											HFCLKIN	10	I	
											UART0_RTS	11	O	
											SPI0_SCLK	12	IOD	
											UART1_RX	13	I	
											TIMA0_C3N	14	O	
17	D3	13	17	17	13	14	8			PA9 PINCM14 0x40428034	PA9	1	IO	SDIO (standar d)
											UART1_RX	2	I	
											SPI0_PICO	3	IO	
											I2C0_SCL	4	IOD	
											TIMA0_C0N	5	O	
											CLK_OUT	6	O	
											TIMA0_C1	7	IO	
											RTC_OUT	8	O	
											TIMG2_C0	9	IO	
											SPI0_POCI	10	IO	
											UART0_CTS	11	I	
											TIMA_FAL1	12	I	
											TIMG1_C1	13	IO	

**Table 6-2. Pin Attributes (PT (A), ZCM, VFC, PT (B), RGZ, RHB, DGS28, RGE, DGS20, RUK Packages)  
(continued)**

PT (A) PIN	ZCM PIN	VFC PIN	PT (B) PIN	RGZ PIN	RHB PIN	DGS28 PIN	RGE PIN	DGS20 PIN	RUK PIN	PIN NAME/ IOMUX REG/ IOMUX ADDR	SIGNAL NAME	IOMUX PF	SIGNAL TYPE	BUFFER TYPE
18	D2	14	18	18	14	15	9			PA10 PINCM15 0x40428038	PA10	1	IO	SDIO (standar d)with wake
											UART0_TX	2	O	
											SPI0_POCI	3	IO	
											I2C0_SDA	4	IOD	
											TIMA0_C2	5	IO	
											CLK_OUT	6	O	
											TIMG14_C0	7	IO	
											I2C1_SDA	8	IOD	
											TIMA_FAL1	10	I	
											TIMG2_C1	11	IO	
											TIMA0_C1N	12	O	
											TIMG8_C1	13	IO	
											SPI0_PICO	14	IO	
											19	E4	15	
UART0_RX	2	IO												
SPI0_SCLK	3	IOD												
I2C0_SCL	4	IOD												
TIMA0_C2N	5	O												
UART1_RX	6	I												
TIMG14_C1	7	IO												
I2C1_SCL	8	IOD												
TIMA_FAL0	10	I												
SPI0_CS0	12	IO												
COMP0_OUT	14	O												
ADC0_25	(Non-IOMUX 1) 0	A												
COMP0_DAC_OUT	(Non-IOMUX 2) 0	A												
27	G2		27	27	16					PA12 PINCM24 0x4042805c	PA12	1	IO	SDIO (standar d)
											SPI0_SCLK	2	IOD	
											TIMA0_C3	4	IO	
											FCC_IN	5	I	
											TIMG14_C0	6	IO	
											SPI0_CS1_MISO1	8	IO	
											UART2_CTS	9	I	
											UART1_CTS	10	I	
											TIMA0_C3N	11	O	
											I2C1_SCL	12	IOD	
											TIMG2_C1	13	IO	
											COMP0_OUT	14	O	
											ADC0_18	(Non-IOMUX 1) 0	A	

**Table 6-2. Pin Attributes (PT (A), ZCM, VFC, PT (B), RGZ, RHB, DGS28, RGE, DGS20, RUK Packages)**  
**(continued)**

PT (A) PIN	ZCM PIN	VFC PIN	PT (B) PIN	RGZ PIN	RHB PIN	DGS2 8 PIN	RGE PIN	DGS2 0 PIN	RUK PIN	PIN NAME/ IOMUX REG/ IOMUX ADDR	SIGNAL NAME	IOMUX PF	SIGNAL TYPE	BUFFER TYPE
28	G3	18	28	28	17					PA13 PINCM25 0x40428060	PA13	1	IO	SDIO (standar d)
											UART0_RX	2	IO	
											SPI0_POCI	3	IO	
											TIMA0_C2N	4	O	
											TIMA0_C3N	5	O	
											RTC_OUT	6	O	
											TIMG14_C1	7	IO	
											TIMG14_C3	8	IO	
											SPI0_CS3_CD _MISO3	9	IO	
											UART2_TX	10	O	
											UART1_RTS	11	O	
											SPI0_CS0	12	IO	
											TIMG8_C1	13	IO	
											TIMA0_C1	14	IO	
											ADC0_17	(Non-IOMUX 1) 0	A	
COMP0_IN2-	(Non-IOMUX 2) 0	A												
29	F3	19	29	29	18	17				PA14 PINCM26 0x40428064	PA14	1	IO	SDIO (standar d)
											UART0_CTS	2	I	
											SPI0_PICO	3	IO	
											TIMG1_C0	4	IO	
											CLK_OUT	6	O	
											SPI0_CS2_MIS O2	9	IO	
											UART2_RX	10	I	
											I2C0_SCL	12	IOD	
											UART0_TX	13	O	
											TIMA0_C2	14	IO	
											ADC0_16	(Non-IOMUX 1) 0	A	
											COMP0_IN2+	(Non-IOMUX 2) 0	A	
30	G4	20	30	30	19	18	11			PA15 PINCM27 0x40428068	PA15	1	IO	SDIO (standar d)
											UART0_RTS	2	O	
											SPI0_CS2_MIS O2	3	IO	
											I2C1_SCL	4	IOD	
											TIMA0_C2	5	IO	
											TIMG8_IDX	7	I	
											UART2_RTS	10	O	
											TIMG14_C1	12	IO	
ADC0_15	(Non-IOMUX 1) 0	A												
COMP0_IN3+	(Non-IOMUX 2) 0	A												

**Table 6-2. Pin Attributes (PT (A), ZCM, VFC, PT (B), RGZ, RHB, DGS28, RGE, DGS20, RUK Packages)  
(continued)**

PT (A) PIN	ZCM PIN	VFC PIN	PT (B) PIN	RGZ PIN	RHB PIN	DGS28 PIN	RGE PIN	DGS20 PIN	RUK PIN	PIN NAME/ IOMUX REG/ IOMUX ADDR	SIGNAL NAME	IOMUX PF	SIGNAL TYPE	BUFFER TYPE
31	F4		31	31	20	19	12	12	10	PA16 PINCM28 0x4042806c	PA16	1	IO	SDIO (standar d)
											SPI0_POCI	3	IO	
											I2C1_SDA	4	IOD	
											TIMA0_C2N	5	O	
											FCC_IN	7	I	
											UART2_CTS	10	I	
											TIMG14_C2	12	IO	
											COMP0_OUT	14	O	
ADC0_14	(Non-IOMUX 1) 0	A												
32	G5	21	32	32	21	20	13	13	11	PA17 PINCM29 0x40428070	PA17	1	IO	SDIO (standar d)
											UART1_TX	2	O	
											TIMA0_C2	3	IO	
											I2C1_SCL	4	IOD	
											TIMA0_C3	5	IO	
											TIMG2_C0	6	IO	
											TIMG8_C0	7	IO	
											TIMA0_C0N	8	O	
											SPI0_CS1_MIS O1	9	IO	
											SPI0_SCLK	10	IOD	
											I2C0_SDA	11	IOD	
											UART0_RX	12	IO	
											ADC0_13	(Non-IOMUX 1) 0	A	
COMP0_IN1-	(Non-IOMUX 2) 0	A												
33	F5	22	33	33	22	21	14	14	12	PA18 PINCM30 0x40428074	PA18	1	IO	SDIO (standar d)
											UART1_RX	2	I	
											UART1_RTS	3	O	
											I2C1_SDA	4	IOD	
											TIMA0_C3N	5	O	
											TIMG2_C1	6	IO	
											TIMG8_C1	7	IO	
											SPI0_PICO	8	IO	
											SPI0_CS0	9	IO	
											TIMA0_C1N	10	O	
											TIMA0_C0	11	IO	
											SPI0_POCI	12	IO	
											TIMA_FAL2	13	I	
											CLK_OUT	14	O	
											ADC0_12	(Non-IOMUX 1) 0	A	
COMP0_IN1+	(Non-IOMUX 2) 0	A												
Table 6-4	(Non-IOMUX 2) 0	I												

**Table 6-2. Pin Attributes (PT (A), ZCM, VFC, PT (B), RGZ, RHB, DGS28, RGE, DGS20, RUK Packages)**  
**(continued)**

PT (A) PIN	ZCM PIN	VFC PIN	PT (B) PIN	RGZ PIN	RHB PIN	DGS28 PIN	RGE PIN	DGS20 PIN	RUK PIN	PIN NAME/ IOMUX REG/ IOMUX ADDR	SIGNAL NAME	IOMUX PF	SIGNAL TYPE	BUFFER TYPE
34	B6	24	35	34	23	22	15	15	13	PA19 PINCM32 0x4042807c	PA19	1	IO	SDIO (standar d)
											SWDIO	2	IO	
											SPI0_SCLK	3	IOD	
											I2C1_SDA	4	IOD	
											TIMA0_C2	5	IO	
											TIMG14_C0	6	IO	
											SPI0_POCI	7	IO	
											UART0_CTS	8	I	
											UART1_RX	11	I	
											SPI0_PICO	13	IO	
ADC0_22	(Non-IOMUX 1) 0	A												
35	G6	25	36	35	24	23	16	16	14	PA20 PINCM33 0x40428080	PA20	1	IO	SDIO (standar d)
											SWCLK	2	I	
											TIMA_FAL1	3	I	
											I2C1_SCL	4	IOD	
											TIMA0_C2N	5	O	
											TIMG14_C1	6	IO	
											SPI0_PICO	7	IO	
											TIMA0_C0	8	IO	
											UART0_RTS	10	O	
											UART1_TX	11	O	
											SPI0_CS0	12	IO	
											UART1_RX	13	I	
ADC0_4	(Non-IOMUX 1) 0	A												
39	E6		39	39	25	24	17			PA21 PINCM37 0x40428090	PA21	1	IO	SDIO (standar d)
											UART2_TX	2	O	
											SPI0_CS3_CD_MISO3	3	IO	
											UART1_CTS	4	I	
											TIMA0_C0	5	IO	
											TIMG1_C0	6	IO	
											UART2_CTS	8	I	
											TIMG8_C0	10	IO	
											TIMA0_CON	12	O	
											UART2_RX	13	I	
											ADC0_8	(Non-IOMUX 1) 0	A	
ADC0_VREF-	(Non-IOMUX 2) 0	A												

**Table 6-2. Pin Attributes (PT (A), ZCM, VFC, PT (B), RGZ, RHB, DGS28, RGE, DGS20, RUK Packages)  
(continued)**

PT (A) PIN	ZCM PIN	VFC PIN	PT (B) PIN	RGZ PIN	RHB PIN	DGS28 PIN	RGE PIN	DGS20 PIN	RUK PIN	PIN NAME/ IOMUX REG/ IOMUX ADDR	SIGNAL NAME	IOMUX PF	SIGNAL TYPE	BUFFER TYPE
40	F7		40	40	26	25	18	17	15	PA22 PINCM38 0x40428094	PA22	1	IO	SDIO (standar d)
											UART2_RX	2	I	
											SPI0_CS2_MISO2	3	IO	
											UART1_RTS	4	O	
											TIMA0_C0N	5	O	
											TIMG1_C1	6	IO	
											TIMA0_C1	7	IO	
											CLK_OUT	8	O	
											I2C0_SCL	9	IOD	
											TIMG8_C1	10	IO	
											UART1_RX	11	I	
											SPI0_POCI	12	IO	
											UART2_TX	13	O	
ADC0_7	(Non-IOMUX 1) 0	A												
43	D7		43	43	27	26	19	18	16	PA23 PINCM41 0x404280a0	PA23	1	IO	SDIO (standar d)
											UART2_TX	2	O	
											SPI0_CS3_CD_MISO3	3	IO	
											TIMA0_C3	5	IO	
											TIMG8_C0	6	IO	
											TIMG2_C0	7	IO	
											UART0_TX	8	O	
											TIMG14_C0	9	IO	
											SPI0_POCI	12	IO	
											UART0_CTS	13	I	
											ADC0_26	(Non-IOMUX 1) 0	A	
ADC0_VREF+	(Non-IOMUX 2) 0	A												
44	C7		44	44	28	27	20	19	17	PA24 PINCM42 0x404280a4	PA24	1	IO	SDIO (standar d)
											UART2_RX	2	I	
											SPI0_CS2_MISO2	3	IO	
											UART0_RTS	4	O	
											TIMA0_C3N	5	O	
											TIMG8_C1	6	IO	
											TIMG2_C1	7	IO	
											UART1_RX	8	I	
											TIMG14_C1	9	IO	
											SPI0_PICO	12	IO	
											I2C0_SDA	13	IOD	
											ADC0_3	(Non-IOMUX 1) 0	A	

**Table 6-2. Pin Attributes (PT (A), ZCM, VFC, PT (B), RGZ, RHB, DGS28, RGE, DGS20, RUK Packages)**  
**(continued)**

PT (A) PIN	ZCM PIN	VFC PIN	PT (B) PIN	RGZ PIN	RHB PIN	DGS2 8 PIN	RGE PIN	DGS2 0 PIN	RUK PIN	PIN NAME/ IOMUX REG/ IOMUX ADDR	SIGNAL NAME	IOMUX PF	SIGNAL TYPE	BUFFER TYPE
45	C6	30	45	45	29	28	21	20	18	PA25 PINCM43 0x404280a8	PA25	1	IO	SDIO (standar d)
											SPI0_PICO	2	IO	
											SPI0_POCI	3	IO	
											SPI0_SCLK	4	IOD	
											TIMA0_C3	5	IO	
											TIMA0_C1N	6	O	
											TIMA0_C2	7	IO	
											UART2_CTS	8	I	
											TIMG14_C0	9	IO	
											TIMG1_C0	10	IO	
											I2C0_SDA	11	IOD	
											UART0_TX	12	O	
											TIMA_FAL2	13	I	
											I2C0_SCL	14	IOD	
ADC0_2	(Non-IOMUX 1) 0	A												
46	B7	31	46	46	30	1	22	1	19	PA26 PINCM44 0x404280ac	PA26	1	IO	SDIO (standar d)
											BEEP	2	O	
											SPI0_POCI	3	IO	
											TIMG8_C0	4	IO	
											TIMA_FAL0	5	I	
											TIMA0_C3N	6	O	
											TIMG2_C0	7	IO	
											UART2_RTS	8	O	
											I2C0_SCL	9	IOD	
											TIMG1_C1	10	IO	
											UART0_RX	11	IO	
											TIMA0_C0	12	IO	
											I2C0_SDA	13	IOD	
											UART1_CTS	14	I	
ADC0_1	(Non-IOMUX 1) 0	A												
COMP0_IN0+	(Non-IOMUX 2) 0	A												

**Table 6-2. Pin Attributes (PT (A), ZCM, VFC, PT (B), RGZ, RHB, DGS28, RGE, DGS20, RUK Packages)  
(continued)**

PT (A) PIN	ZCM PIN	VFC PIN	PT (B) PIN	RGZ PIN	RHB PIN	DGS28 PIN	RGE PIN	DGS20 PIN	RUK PIN	PIN NAME/ IOMUX REG/ IOMUX ADDR	SIGNAL NAME	IOMUX PF	SIGNAL TYPE	BUFFER TYPE
47	A7	32	47	47	31	2		2	20	PA27 PINCM45 0x404280b0	PA27	1	IO	SDIO (standar d)
											SPI0_CS3_CD_MISO3	2	IO	
											TIMA0_C0N	3	O	
											TIMG8_C1	4	IO	
											TIMA_FAL2	5	I	
											CLK_OUT	6	O	
											TIMG2_C1	7	IO	
											RTC_OUT	8	O	
											UART1_CTS	9	I	
											I2C0_SCL	10	IOD	
											UART0_TX	11	O	
											SPI0_POCI	12	IO	
											COMP0_OUT	14	O	
ADC0_0	(Non-IOMUX 1) 0	A												
COMP0_IN0-	(Non-IOMUX 2) 0	A												
3	B5	3	3	3						PA28 PINCM3 0x40428008	PA28	1	IO	SDIO (standar d)
											UART0_TX	2	O	
											I2C0_SDA	3	IOD	
											TIMA0_C3	4	IO	
											TIMA_FAL0	5	I	
											TIMG2_C0	6	IO	
TIMA0_C1	7	IO												
		23	34							PA29 PINCM31 0x40428078	PA29	1	IO	SDIO (standar d)
											UART0_RTS	2	O	
											SPI0_PICO	3	IO	
48	D5	1	48	48	32	3	23	3	1	PA30 PINCM46 0x404280b4	PA30	1	IO	SDIO (standar d)
											UART0_RX	4	IO	
											TIMG8_IDX	5	I	
											TIMA0_C0	6	IO	
											UART1_RTS	9	O	
											TIMG2_C1	10	IO	
											TIMG14_C2	11	IO	
I2C0_SDA	12	IOD												
5	B4		4	5						PA31 PINCM4 0x4042800c	PA31	1	IO	SDIO (standar d)
											UART0_RX	2	IO	
											I2C0_SCL	3	IOD	
											TIMA0_C3N	4	O	
											CLK_OUT	6	O	

**Table 6-2. Pin Attributes (PT (A), ZCM, VFC, PT (B), RGZ, RHB, DGS28, RGE, DGS20, RUK Packages)**  
(continued)

PT (A) PIN	ZCM PIN	VFC PIN	PT (B) PIN	RGZ PIN	RHB PIN	DGS28 PIN	RGE PIN	DGS20 PIN	RUK PIN	PIN NAME/ IOMUX REG/ IOMUX ADDR	SIGNAL NAME	IOMUX PF	SIGNAL TYPE	BUFFER TYPE
14	B3	10	14	14						PB2 PINCM11 0x40428028	PB2	1	IO	SDIO (standar d)
											UART2_CTS	3	I	
											I2C1_SCL	4	IOD	
											TIMA0_C3	5	IO	
											UART1_CTS	6	I	
											TIMG1_C0	7	IO	
											UART2_TX	8	O	
											HFCLKIN	10	I	
											SPI0_PICO	11	IO	
											UART1_RX	12	I	
											TIMA0_C1N	13	O	
15	C2	11	15	15					8	PB3 PINCM12 0x4042802c	PB3	1	IO	SDIO (standar d)
											TIMA_FAL0	2	I	
											UART2_RTS	3	O	
											I2C1_SDA	4	IOD	
											TIMA0_C3N	5	O	
											UART1_RTS	6	O	
											TIMG1_C1	7	IO	
											UART2_RX	8	I	
											TIMG2_C1	9	IO	
											TIMA0_C0	10	IO	
											SPI0_SCLK	11	IOD	
											SPI0_CS0	12	IO	
											UART1_TX	13	O	
RTC_OUT	14	O												
20	D1	16	20	20						PB6 PINCM17 0x40428040	PB6	1	IO	SDIO (standar d)
											UART1_TX	2	O	
											TIMG8_C0	5	IO	
											UART2_CTS	6	I	
											TIMG1_C0	7	IO	
											TIMA_FAL2	8	I	
											SPI0_CS1_MIS O1	9	IO	
											TIMA0_C3N	11	O	
											TIMG8_C1	12	IO	
											TIMA0_C2N	13	O	
											UART0_TX	14	O	
ADC0_24	(Non-IOMUX 1) 0	A												

**Table 6-2. Pin Attributes (PT (A), ZCM, VFC, PT (B), RGZ, RHB, DGS28, RGE, DGS20, RUK Packages)**  
(continued)

PT (A) PIN	ZCM PIN	VFC PIN	PT (B) PIN	RGZ PIN	RHB PIN	DGS28 PIN	RGE PIN	DGS20 PIN	RUK PIN	PIN NAME/ IOMUX REG/ IOMUX ADDR	SIGNAL NAME	IOMUX PF	SIGNAL TYPE	BUFFER TYPE
21	E1	17	21	21						PB7 PINCM18 0x40428044	PB7	1	IO	SDIO (standard)
											UART1_RX	2	I	
											TIMG8_C1	5	IO	
											UART2_RTS	6	O	
											TIMG1_C1	7	IO	
											SPI0_CS2_MISO2	9	IO	
											BEEP	12	O	
											SPI0_SCLK	13	IOD	
											UART0_RX	14	IO	
ADC0_23	(Non-IOMUX 1) 0	A												
22	F1		22	22						PB8 PINCM19 0x40428048	PB8	1	IO	SDIO (standard)
											UART1_CTS	2	I	
											TIMA0_C0	3	IO	
											TIMG1_C0	5	IO	
											SPI0_SCLK	7	IOD	
											BEEP	8	O	
											TIMG8_C0	9	IO	
											UART0_RX	10	IO	
											SPI0_POCI	11	IO	
											I2C0_SCL	12	IOD	
COMP0_OUT	14	O												
23	E3		23	23						PB9 PINCM20 0x4042804c	PB9	1	IO	SDIO (standard)
											UART1_RTS	2	O	
											TIMA0_CON	5	O	
											TIMA0_C1	6	IO	
											TIMG1_C1	7	IO	
											TIMG2_C0	8	IO	
											SPI0_POCI	10	IO	
											UART0_RX	11	IO	
											I2C0_SCL	12	IOD	
											UART0_TX	13	O	
I2C0_SDA	14	IOD												
24	G1		24	24						PB14 PINCM21 0x40428050	PB14	1	IO	SDIO (standard)
											TIMA0_C0	5	IO	
											TIMG8_IDX	6	I	
											SPI0_CS3_CD_MISO3	7	IO	
											TIMG2_C1	8	IO	
											I2C0_SDA	9	IOD	
											SPI0_PICO	10	IO	
											UART0_TX	11	O	
											TIMA_FAL2	12	I	
											TIMA_FAL0	13	I	
											TIMG14_C2	14	IO	
ADC0_21	(Non-IOMUX 1) 0	A												

**Table 6-2. Pin Attributes (PT (A), ZCM, VFC, PT (B), RGZ, RHB, DGS28, RGE, DGS20, RUK Packages)**  
**(continued)**

PT (A) PIN	ZCM PIN	VFC PIN	PT (B) PIN	RGZ PIN	RHB PIN	DGS2 8 PIN	RGE PIN	DGS2 0 PIN	RUK PIN	PIN NAME/ IOMUX REG/ IOMUX ADDR	SIGNAL NAME	IOMUX PF	SIGNAL TYPE	BUFFER TYPE
25	E2		25	25						PB15 PINCM22 0x40428054	PB15	1	IO	SDIO (standar d)
											UART2_TX	2	O	
											TIMG8_C0	5	IO	
											TIMG2_C0	6	IO	
											TIMA0_C1N	12	O	
											UART1_TX	13	O	
											TIMG2_C1	14	IO	
ADC0_20	(Non-IOMUX 1) 0	A												
26	F2		26	26						PB16 PINCM23 0x40428058	PB16	1	IO	SDIO (standar d)
											UART2_RX	2	I	
											TIMG8_C1	5	IO	
											TIMG2_C1	6	IO	
											TIMA0_C2N	12	O	
											UART1_RX	13	I	
											I2C1_SDA	14	IOD	
ADC0_19	(Non-IOMUX 1) 0	A												
36	G7		36	36						PB17 PINCM34 0x40428084	PB17	1	IO	SDIO (standar d)
											UART2_TX	2	O	
											SPI0_PICO	3	IO	
											I2C0_SCL	4	IOD	
											TIMA0_C2	5	IO	
											TIMG14_C0	6	IO	
											TIMG1_C0	9	IO	
											SPI0_CS0	10	IO	
ADC0_11	(Non-IOMUX 1) 0	A												
37	E5	26	37	37						PB18 PINCM35 0x40428088	PB18	1	IO	SDIO (standar d)
											UART2_RX	2	I	
											SPI0_SCLK	3	IOD	
											I2C0_SDA	4	IOD	
											TIMA0_C2N	5	O	
											TIMG14_C1	6	IO	
											SPI0_CS0	7	IO	
											TIMG1_C1	9	IO	
											TIMA0_C1	12	IO	
											UART0_RTS	13	O	
ADC0_10	(Non-IOMUX 1) 0	A												

**Table 6-2. Pin Attributes (PT (A), ZCM, VFC, PT (B), RGZ, RHB, DGS28, RGE, DGS20, RUK Packages)  
(continued)**

PT (A) PIN	ZCM PIN	VFC PIN	PT (B) PIN	RGZ PIN	RHB PIN	DGS28 PIN	RGE PIN	DGS20 PIN	RUK PIN	PIN NAME/ IOMUX REG/ IOMUX ADDR	SIGNAL NAME	IOMUX PF	SIGNAL TYPE	BUFFER TYPE
38	F6		38	38						PB19 PINCM36 0x4042808c	PB19	1	IO	SDIO (standar d)
											SPI0_POCI	3	IO	
											TIMG8_C1	4	IO	
											UART0_CTS	5	I	
											TIMG2_C1	6	IO	
											TIMG8_IDX	7	I	
											UART2_CTS	8	I	
											TIMA0_C1N	12	O	
											UART2_RX	13	I	
											COMP0_OUT	14	O	
ADC0_9	(Non-IOMUX 1) 0	A												
41	E7		41	41						PB20 PINCM39 0x40428098	PB20	1	IO	SDIO (standar d)
											SPI0_CS2_MIS O2	2	IO	
											TIMA0_C2	5	IO	
											TIMA_FAL1	6	I	
											TIMA0_C1	7	IO	
											UART2_RTS	8	O	
											I2C0_SDA	9	IOD	
											UART1_CTS	12	I	
											TIMA0_C2N	13	O	
											TIMG8_C1	14	IO	
ADC0_6	(Non-IOMUX 1) 0	A												
42	D6	27	42	42						PB24 PINCM40 0x4042809c	PB24	1	IO	SDIO (standar d)
											SPI0_CS3_CD _MISO3	2	IO	
											SPI0_CS1_MIS O1	3	IO	
											TIMA0_C3	5	IO	
											TIMA0_C1N	6	O	
											UART2_RTS	8	O	
											SPI0_SCLK	12	IOD	
											TIMG14_C2	13	IO	
											UART0_RTS	14	O	
											ADC0_5	(Non-IOMUX 1) 0	A	
6	A6	4	6	6	4	7	3	6	4	VDD	VDD	(Non-IOMUX 1) 0	PWR	PWR
7	A5	5	7	7	5	8	4	7	5	VSS	VSS	(Non-IOMUX 1) 0	PWR	PWR

### 6.3 Signal Descriptions

**Table 6-3. Analog to Digital Converter (ADC) Signal Descriptions**

SIGNAL NAME	PIN TYPE	DESCRIPTION	PT (A) PIN	ZCM PIN	VFC PIN	PT (B) PIN	RGZ PIN	RHB PIN	RGE PIN	DGS20 PIN	RUK PIN
ADC0_VREF+	A	ADC0 voltage reference (VREF) power supply	43	D7	28	43	43	27	19	18	16

**Table 6-3. Analog to Digital Converter (ADC) Signal Descriptions (continued)**

SIGNAL NAME	PIN TYPE	DESCRIPTION	PT (A) PIN	ZCM PIN	VFC PIN	PT (B) PIN	RGZ PIN	RHB PIN	RGE PIN	DGS20 PIN	RUK PIN
ADC0_VREF-	A	ADC0 voltage reference (VREF) ground supply	39	E6		39	39	25	17		
ADC0_0	A	ADC0 analog input channel 0	47	A7	32	47	47	31		2	20
ADC0_1	A	ADC0 analog input channel 1	46	B7	31	46	46	30	22	1	19
ADC0_2	A	ADC0 analog input channel 2	45	C6	30	45	45	29	21	20	18
ADC0_3	A	ADC0 analog input channel 3	44	C7	29	44	44	28	20	19	17
ADC0_4	A	ADC0 analog input channel 4	35	G6	25	36	35	24	16	16	14
ADC0_5	A	ADC0 analog input channel 5	42	D6	27	42	42				
ADC0_6	A	ADC0 analog input channel 6	41	E7		41	41				
ADC0_7	A	ADC0 analog input channel 7	40	F7		40	40	26	18	17	15
ADC0_8	A	ADC0 analog input channel 8	39	E6		39	39	25	17		
ADC0_9	A	ADC0 analog input channel 9	38	F6		38	38				
ADC0_10	A	ADC0 analog input channel 10	37	E5	26	37	37				
ADC0_11	A	ADC0 analog input channel 11	36	G7			36				
ADC0_12	A	ADC0 analog input channel 12	33	F5	22	33	33	22	14	14	12
ADC0_13	A	ADC0 analog input channel 13	32	G5	21	32	32	21	13	13	11
ADC0_14	A	ADC0 analog input channel 14	31	F4		31	31	20	12	12	10
ADC0_15	A	ADC0 analog input channel 15	30	G4	20	30	30	19	11		
ADC0_16	A	ADC0 analog input channel 16	29	F3	19	29	29	18			
ADC0_17	A	ADC0 analog input channel 17	28	G3	18	28	28	17			
ADC0_18	A	ADC0 analog input channel 18	27	G2		27	27	16			
ADC0_19	A	ADC0 analog input channel 19	26	F2		26	26				
ADC0_20	A	ADC0 analog input channel 20	25	E2		25	25				
ADC0_21	A	ADC0 analog input channel 21	24	G1		24	24				
ADC0_22	A	ADC0 analog input channel 22	34	B6	24	35	34	23	15	15	13
ADC0_23	A	ADC0 analog input channel 23	21	E1	17	21	21				
ADC0_24	A	ADC0 analog input channel 24	20	D1	16	20	20				
ADC0_25	A	ADC0 analog input channel 25	19	E4	15	19	19	15	10	11	9
ADC0_26	A	ADC0 analog input channel 26	43	D7	28	43	43	27	19	18	16

**Table 6-4. Flash Bootstrap Loader (BSL) Signal Descriptions**

SIGNAL NAME	PIN TYPE	DESCRIPTION	PT (A) PIN	ZCM PIN	VFC PIN	PT (B) PIN	RGZ PIN	RHB PIN	DGS28 PIN	RGE PIN	DGS20 PIN	RUK PIN
BSL_invoke (Flash)	I	Default Flash BSL invoke signal	33	F5	22	33	33	22	21	14	14	12

**Table 6-5. Clock Module (CKM) Signal Descriptions**

SIGNAL NAME	PIN TYPE	DESCRIPTION	PT (A) PIN	ZCM PIN	VFC PIN	PT (B) PIN	RGZ PIN	RHB PIN	DGS28 PIN	RGE PIN	DGS20 PIN	RUK PIN
CLK_OUT	O	CLK_OUT digital clock output from the PMCU	13, 17, 18, 29, 33, 40, 47, 5	A7, B2, B4, D2, D3, F3, F5, F7	13, 14, 19, 22, 32, 9	13, 17, 18, 29, 33, 4, 40, 47	13, 17, 18, 29, 33, 40, 47, 5	11, 13, 14, 18, 22, 26, 31	14, 15, 17, 2, 25	14, 18, 8, 9	14, 17, 2	12, 15, 20

**Table 6-5. Clock Module (CKM) Signal Descriptions (continued)**

SIGNAL NAME	PIN TYPE	DESCRIPTION	PT (A) PIN	ZCM PIN	VFC PIN	PT (B) PIN	RGZ PIN	RHB PIN	DGS2 8 PIN	RGE PIN	DGS2 0 PIN	RUK PIN
FCC_IN	I	Frequency clock counter (FCC) input signal	1, 11, 13, 27, 31	B1, B2, D4, F4, G2	7, 9	1, 11, 13, 27, 31	1, 11, 13, 27, 31	1, 11, 16, 20, 9	12, 19, 4	12, 24	12, 4	10, 2
HFCLKIN	I	High frequency clock digital clock input signal	10, 12, 14, 16, 2	A2, B3, C1, C4, C5	10, 12, 2, 8	12, 14, 16, 2, 9	10, 12, 14, 16, 2	10, 12, 2, 8	11, 13, 5	1, 7	10, 5, 9	3, 7
HFXIN	A	High frequency crystal oscillator (HFXT) signal	11	B1	7	11	11	9	12			
HFXOUT	A	High frequency crystal oscillator (HFXT) signal	12	C1	8	12	12	10	13		10	
LFCLKIN	I	Low frequency clock digital clock input signal	10	A2		9	10	8	11	7	9	7
LFXIN	A	Low frequency crystal oscillator (LFXT) signal	9	A3		8	9	7	10	6		
LFXOUT	A	Low frequency crystal oscillator (LFXT) signal	10	A2		9	10	8	11	7	9	7

**Table 6-6. Comparator (COMP) Signal Descriptions**

SIGNAL NAME	PIN TYPE	DESCRIPTION	PT (A) PIN	ZCM PIN	VFC PIN	PT (B) PIN	RGZ PIN	RHB PIN	DGS2 8 PIN	RGE PIN	DGS2 0 PIN	RUK PIN
COMP0_DAC_OUT	A	COMP0 DAC output	19	E4	15	19	19	15	16	10	11	9
COMP0_OUT	O	COMP0 output	13, 19, 22, 27, 31, 38, 47, 9	A3, A7, B2, E4, F1, F4, F6, G2	15, 32, 9	13, 19, 22, 27, 31, 38, 47, 8	13, 19, 22, 27, 31, 38, 47, 9	11, 15, 16, 20, 31, 7	10, 16, 19, 2	10, 12, 6	11, 12, 2	10, 20, 9
COMP0_IN0+	A	COMP0 non-inverting input 0	46	B7	31	46	46	30	1	22	1	19
COMP0_IN0-	A	COMP0 inverting input 0	47	A7	32	47	47	31	2		2	20
COMP0_IN1+	A	COMP0 non-inverting input 1	33	F5	22	33	33	22	21	14	14	12
COMP0_IN1-	A	COMP0 inverting input 1	32	G5	21	32	32	21	20	13	13	11
COMP0_IN2+	A	COMP0 non-inverting input 2	29	F3	19	29	29	18	17			
COMP0_IN2-	A	COMP0 inverting input 2	28	G3	18	28	28	17				
COMP0_IN3+	A	COMP0 non-inverting input 3	30	G4	20	30	30	19	18	11		

**Table 6-7. General Purpose Input Output Module Signal Descriptions**

SIGNAL NAME	PIN TYPE	DESCRIPTION	PT (A) PIN	ZCM PIN	VFC PIN	PT (B) PIN	RGZ PIN	RHB PIN	DGS2 8 PIN	RGE PIN	DGS2 0 PIN	RUK PIN
PA0	IO	GPIO port A input/output 0	1	D4		1	1	1	4	24	4	2
PA1	IO	GPIO port A input/output 1	2	C5	2	2	2	2	5	1	5	3
PA2	IO	GPIO port A input/output 2	8	A4			8	6	9	5	8	6
PA3	IO	GPIO port A input/output 3	9	A3			8	9	7	10	6	
PA4	IO	GPIO port A input/output 4	10	A2			9	10	8	11	7	9

**Table 6-7. General Purpose Input Output Module Signal Descriptions (continued)**

SIGNAL NAME	PIN TYPE	DESCRIPTION	PT (A) PIN	ZCM PIN	VFC PIN	PT (B) PIN	RGZ PIN	RHB PIN	DGS2 8 PIN	RGE PIN	DGS2 0 PIN	RUK PIN
PA5	IO	GPIO port A input/output 5	11	B1	7	11	11	9	12			
PA6	IO	GPIO port A input/output 6	12	C1	8	12	12	10	13		10	
PA7	IO	GPIO port A input/output 7	13	B2	9	13	13	11				
PA8	IO	GPIO port A input/output 8	16	C4	12	16	16	12				
PA9	IO	GPIO port A input/output 9	17	D3	13	17	17	13	14	8		
PA10	IO	GPIO port A input/output 10	18	D2	14	18	18	14	15	9		
PA11	IO	GPIO port A input/output 11	19	E4	15	19	19	15	16	10	11	9
PA12	IO	GPIO port A input/output 12	27	G2		27	27	16				
PA13	IO	GPIO port A input/output 13	28	G3	18	28	28	17				
PA14	IO	GPIO port A input/output 14	29	F3	19	29	29	18	17			
PA15	IO	GPIO port A input/output 15	30	G4	20	30	30	19	18	11		
PA16	IO	GPIO port A input/output 16	31	F4		31	31	20	19	12	12	10
PA17	IO	GPIO port A input/output 17	32	G5	21	32	32	21	20	13	13	11
PA18	IO	GPIO port A input/output 18	33	F5	22	33	33	22	21	14	14	12
PA19	IO	GPIO port A input/output 19	34	B6	24	35	34	23	22	15	15	13
PA20	IO	GPIO port A input/output 20	35	G6	25	36	35	24	23	16	16	14
PA21	IO	GPIO port A input/output 21	39	E6		39	39	25	24	17		
PA22	IO	GPIO port A input/output 22	40	F7		40	40	26	25	18	17	15
PA23	IO	GPIO port A input/output 23	43	D7	28	43	43	27	26	19	18	16
PA24	IO	GPIO port A input/output 24	44	C7	29	44	44	28	27	20	19	17
PA25	IO	GPIO port A input/output 25	45	C6	30	45	45	29	28	21	20	18
PA26	IO	GPIO port A input/output 26	46	B7	31	46	46	30	1	22	1	19
PA27	IO	GPIO port A input/output 27	47	A7	32	47	47	31	2		2	20
PA28	IO	GPIO port A input/output 28	3	B5	3	3	3					
PA29	IO	GPIO port A input/output 29			23	34						
PA30	IO	GPIO port A input/output 30	48	D5	1	48	48	32	3	23	3	1
PA31	IO	GPIO port A input/output 31	5	B4		4	5					
PB2	IO	GPIO port B input/output 2	14	B3	10	14	14					
PB3	IO	GPIO port B input/output 3	15	C2	11	15	15					8
PB6	IO	GPIO port B input/output 6	20	D1	16	20	20					
PB7	IO	GPIO port B input/output 7	21	E1	17	21	21					
PB8	IO	GPIO port B input/output 8	22	F1		22	22					
PB9	IO	GPIO port B input/output 9	23	E3		23	23					
PB14	IO	GPIO port B input/output 14	24	G1		24	24					
PB15	IO	GPIO port B input/output 15	25	E2		25	25					
PB16	IO	GPIO port B input/output 16	26	F2		26	26					
PB17	IO	GPIO port B input/output 17	36	G7			36					
PB18	IO	GPIO port B input/output 18	37	E5	26	37	37					
PB19	IO	GPIO port B input/output 19	38	F6		38	38					
PB20	IO	GPIO port B input/output 20	41	E7		41	41					
PB24	IO	GPIO port B input/output 24	42	D6	27	42	42					

**Table 6-8. I2C Signal Descriptions**

SIGNAL NAME	PIN TYPE	DESCRIPTION	PT (A) PIN	ZCM PIN	VFC PIN	PT (B) PIN	RGZ PIN	RHB PIN	DGS2 8 PIN	RGE PIN	DGS2 0 PIN	RUK PIN
I2C0_SCL	IOD	I2C0 serial clock signal (SCL)	17, 19, 2, 22, 23, 29, 36, 40, 45, 46, 47, 5, 8	A4, A7, B4, B7, C5, C6, D3, E3, E4, F1, F3, F7, G7	13, 15, 19, 2, 30, 31, 32	17, 19, 2, 22, 23, 29, 4, 40, 45, 46, 47	17, 19, 2, 22, 23, 29, 4, 40, 45, 46, 47, 5, 8	13, 15, 19, 2, 22, 23, 29, 4, 40, 45, 46, 47, 5, 8	1, 14, 16, 17, 2, 25, 28, 5, 9	1, 10, 18, 21, 22, 5, 8	1, 11, 17, 2, 20, 5, 8	15, 18, 19, 20, 3, 6, 9
I2C0_SDA	IOD	I2C0 serial data signal (SDA)	1, 12, 16, 18, 2, 23, 24, 3, 32, 37, 41, 44, 45, 46, 48, 9	A3, B5, B7, C1, C4, C5, C6, C7, D2, D4, D5, E3, E5, E7, G1, G5	1, 12, 14, 2, 21, 26, 29, 3, 30, 31, 8	1, 12, 16, 18, 2, 23, 24, 3, 32, 37, 41, 44, 45, 46, 48, 8	1, 12, 16, 18, 2, 23, 24, 3, 32, 37, 41, 44, 45, 46, 48, 9	1, 10, 12, 13, 14, 2, 21, 28, 29, 30, 32, 7	1, 10, 13, 15, 20, 22, 23, 24, 6, 9	1, 13, 20, 21, 22, 23, 24, 6, 9	1, 10, 13, 19, 20, 3, 4, 5	1, 11, 17, 18, 19, 2, 3
I2C1_SCL	IOD	I2C1 serial clock signal (SCL)	10, 12, 14, 19, 27, 30, 32, 35	A2, B3, C1, E4, G2, G4, G5, G6	10, 15, 20, 21, 25, 8	12, 14, 19, 27, 30, 32, 36, 9	10, 12, 14, 19, 27, 30, 32, 35	10, 15, 16, 19, 21, 24, 8	11, 13, 16, 18, 20, 23	10, 11, 13, 16, 7	10, 11, 13, 16, 9	11, 14, 7, 9
I2C1_SDA	IOD	I2C1 serial data signal (SDA)	11, 15, 18, 26, 31, 33, 34, 9	A3, B1, B6, C2, D2, F2, F4, F5	11, 14, 22, 24, 7	11, 15, 18, 26, 31, 33, 35, 8	11, 15, 18, 26, 31, 33, 35, 9	14, 20, 22, 23, 7, 9	10, 12, 15, 19, 21, 22	12, 14, 15, 6, 9	12, 14, 15	10, 12, 13, 8

**Table 6-9. Real-time Clock (RTC) Signal Descriptions**

SIGNAL NAME	PIN TYPE	DESCRIPTION	PT (A) PIN	ZCM PIN	VFC PIN	PT (B) PIN	RGZ PIN	RHB PIN	DGS2 8 PIN	RGE PIN	DGS2 0 PIN	RUK PIN
RTC_OUT	O	Real-time clock output signal	1, 15, 17, 28, 47	A7, C2, D3, D4, G3	11, 13, 18, 32	1, 15, 17, 28, 47	1, 15, 17, 28, 47	1, 13, 17, 31	14, 2, 4	24, 8	2, 4	2, 20, 8

**Table 6-10. Serial Peripheral Interface (SPI) Signal Descriptions**

SIGNAL NAME	PIN TYPE	DESCRIPTION	PT (A) PIN	ZCM PIN	VFC PIN	PT (B) PIN	RGZ PIN	RHB PIN	DGS2 8 PIN	RGE PIN	DGS2 0 PIN	RUK PIN
SPI0_PICO	IO	SPI0 peripheral in controller out signal	11, 13, 14, 17, 18, 24, 29, 33, 34, 35, 36, 44, 45	B1, B2, B3, B6, C6, C7, D2, D3, F3, F5, G1, G6, G7	10, 13, 14, 19, 22, 23, 25, 29, 30, 7, 9	11, 13, 14, 17, 18, 24, 29, 33, 34, 35, 36, 44, 45	11, 13, 14, 17, 18, 24, 29, 33, 34, 35, 36, 44, 45	11, 13, 14, 17, 18, 22, 23, 24, 28, 29, 9	12, 14, 15, 16, 17, 20, 21, 23, 27, 28	14, 15, 16, 20, 21, 8, 9	14, 15, 16, 19, 20	12, 13, 14, 17, 18
SPI0_POCI	IO	SPI0 peripheral out controller in signal	10, 13, 17, 18, 22, 23, 28, 31, 33, 34, 38, 40, 43, 45, 46, 47	A2, A7, B2, B6, B7, C6, D2, D3, D7, E3, F1, F4, F5, F6, F7, G3	13, 14, 18, 22, 24, 28, 30, 31, 31, 32, 9	13, 17, 18, 22, 23, 28, 31, 33, 35, 38, 40, 43, 45, 46, 47, 9	10, 13, 17, 18, 20, 22, 23, 28, 31, 33, 34, 38, 40, 43, 45, 46, 47	11, 13, 14, 17, 20, 22, 23, 26, 27, 29, 30, 31, 8	1, 11, 14, 15, 19, 2, 21, 22, 25, 26, 28	12, 14, 15, 18, 19, 21, 22, 7, 8, 9	1, 12, 14, 15, 17, 18, 2, 20, 9	10, 12, 13, 15, 16, 18, 19, 20, 7
SPI0_SCLK	IOD	SPI0 serial clock	12, 15, 16, 19, 21, 22, 27, 32, 34, 37, 42, 45	B6, C1, C2, C4, C6, D6, E1, E4, E5, F1, G2, G5	11, 12, 15, 17, 21, 24, 26, 27, 30, 8	12, 15, 16, 19, 21, 22, 27, 32, 35, 37, 42, 45	12, 15, 16, 19, 21, 22, 27, 32, 34, 37, 42, 45	10, 12, 15, 16, 21, 23, 29	13, 16, 20, 22, 28	10, 13, 15, 21	10, 11, 13, 15, 20	11, 13, 18, 8, 9
SPI0_CS0	IO	SPI0 chip-select 0 signal	10, 15, 16, 19, 28, 33, 35, 36, 37, 8	A2, A4, C2, C4, E4, E5, F5, G3, G6, G7	11, 12, 15, 18, 22, 25, 26	15, 16, 19, 28, 33, 36, 37, 9	10, 15, 16, 19, 28, 33, 35, 36, 37, 8	12, 15, 17, 22, 24, 6, 8	11, 16, 21, 23, 9	10, 14, 16, 5, 7	11, 14, 16, 8, 9	12, 14, 6, 7, 8, 9
SPI0_CS1_MISO1	IO		1, 20, 27, 32, 42, 9	A3, D1, D4, D6, G2, G5	16, 21, 27	1, 20, 27, 32, 42, 8	1, 20, 27, 32, 42, 9	1, 16, 21, 7	10, 20, 4	13, 24, 6	13, 4	11, 2

**Table 6-10. Serial Peripheral Interface (SPI) Signal Descriptions (continued)**

SIGNAL NAME	PIN TYPE	DESCRIPTION	PT (A) PIN	ZCM PIN	VFC PIN	PT (B) PIN	RGZ PIN	RHB PIN	DGS2 8 PIN	RGE PIN	DGS2 0 PIN	RUK PIN
SPI0_CS2_MISO2	IO		13, 21, 29, 30, 40, 41, 44	B2, C7, E1, E7, F3, F7, G4	17, 19, 20, 29, 9	13, 21, 20, 30, 40, 41, 44	13, 21, 29, 30, 40, 41, 44	11, 18, 19, 26, 28	17, 18, 25, 27	11, 18, 20	17, 19	15, 17
SPI0_CS3_CD_MISO3	IO		16, 2, 24, 28, 39, 42, 43, 47, 9	A3, A7, C4, C5, D6, D7, E6, G1, G3	12, 18, 2, 27, 28, 32	16, 2, 24, 27, 39, 42, 43, 47, 8	16, 2, 24, 28, 39, 42, 43, 47, 9	12, 17, 2, 25, 27, 31, 7	10, 2, 24, 26, 5	1, 17, 19, 6	18, 2, 5	16, 20, 3

**Table 6-11. Serial Wire Debug (SWD) Signal Descriptions**

SIGNAL NAME	PIN TYPE	DESCRIPTION	PT (A) PIN	ZCM PIN	VFC PIN	PT (B) PIN	RGZ PIN	RHB PIN	DGS2 8 PIN	RGE PIN	DGS2 0 PIN	RUK PIN
SWCLK	I	Serial wire debug interface clock input signal	35	G6	25	36	35	24	23	16	16	14
SWDIO	IO	Serial wire debug interface data input/output signal	34	B6	24	35	34	23	22	15	15	13

**Table 6-12. System Controller (SYCTL) Signal Descriptions**

SIGNAL NAME	PIN TYPE	DESCRIPTION	PT (A) PIN	ZCM PIN	VFC PIN	PT (B) PIN	RGZ PIN	RHB PIN	DGS2 8 PIN	RGE PIN	DGS2 0 PIN	RUK PIN
BEEP	O	Beep output	1, 12, 21, 22, 46	B7, C1, D4, E1, F1	17, 31, 8	1, 12, 21, 22, 46	1, 12, 21, 22, 46	1, 10, 30	1, 13, 4	22, 24	1, 10, 4	19, 2
NRST	RESET	Active-low reset signal (must be logic high for the device to start)	4	A1	6	10	4	3	6	2	5	3
VDD	PWR	VDD supply	6	A6	4	6	6	4	7	3	6	4
VSS	PWR	VSS (ground)	7	A5	5	7	7	5	8	4	7	5

**Table 6-13. Timer (TIMx) Signal Descriptions**

SIGNAL NAME	PIN TYPE	DESCRIPTION	PT (A) PIN	ZCM PIN	VFC PIN	PT (B) PIN	RGZ PIN	RHB PIN	DGS2 8 PIN	RGE PIN	DGS2 0 PIN	RUK PIN
TIMA0_C0	IO	TIMA0 capture/compare 0 signal	1, 15, 16, 22, 24, 25, 33, 35, 39, 46, 48, 8	A4, B7, C2, C4, D4, D5, E6, F1, F5, G1, G6	1, 11, 12, 22, 25, 31	1, 15, 16, 22, 24, 25, 33, 36, 39, 46, 48, 8	1, 15, 16, 22, 24, 25, 30, 32, 6	1, 12, 22, 24, 25, 30, 32, 6	1, 21, 23, 24, 3, 4, 9	14, 16, 17, 22, 23, 24, 5	1, 14, 16, 3, 4, 8	1, 12, 14, 19, 2, 6, 8

**Table 6-13. Timer (TIMx) Signal Descriptions (continued)**

SIGNAL NAME	PIN TYPE	DESCRIPTION	PT (A) PIN	ZCM PIN	VFC PIN	PT (B) PIN	RGZ PIN	RHB PIN	DGS2 8 PIN	RGE PIN	DGS2 0 PIN	RUK PIN
TIMA0_C1	IO	TIMA0 capture/compare 1 signal	11, 13, 17, 2, 23, 28, 3, 37, 40, 41, 9	A3, B1, B2, B5, C5, D3, E3, E5, E7, F7, G3	13, 18, 2, 26, 3, 7, 9	11, 13, 17, 2, 23, 28, 3, 37, 40, 41, 8	11, 13, 17, 2, 23, 28, 3, 37, 40, 41, 9	11, 13, 17, 2, 23, 26, 7, 9	10, 12, 14, 25, 5	1, 18, 6, 8	17, 5	15, 3
TIMA0_C2	IO	TIMA0 capture/compare 2 signal	12, 13, 18, 29, 30, 32, 34, 36, 41, 45, 9	A3, B2, B6, C1, C6, D2, E7, F3, G4, G5, G7	14, 19, 20, 21, 24, 30, 8, 9	12, 13, 18, 29, 30, 32, 35, 41, 45, 8	12, 13, 18, 29, 30, 32, 34, 36, 41, 45, 9	10, 11, 14, 15, 17, 18, 19, 21, 23, 29, 7	10, 13, 15, 17, 18, 20, 22, 28	11, 13, 15, 21, 6, 9	10, 13, 15, 20	11, 13, 18
TIMA0_C3	IO	TIMA0 capture/compare 3 signal	10, 14, 27, 3, 32, 42, 43, 45	A2, B3, B5, C6, D6, D7, G2, G5	10, 21, 27, 28, 3, 30	14, 27, 3, 32, 42, 43, 45, 9	10, 14, 27, 3, 32, 42, 43, 45	16, 21, 27, 29, 8	11, 20, 26, 28	13, 19, 21, 7	13, 18, 20, 9	11, 16, 18, 7
TIMA0_CON	O	TIMA0 capture/compare 0 complementary output	10, 17, 23, 32, 39, 40, 47	A2, A7, D3, E3, E6, F7, G5	13, 21, 32	17, 23, 32, 39, 40, 47, 9	10, 17, 23, 32, 39, 40, 47	13, 21, 25, 26, 31, 8	11, 14, 2, 20, 24, 25	13, 17, 18, 7, 8	13, 17, 2, 9	11, 15, 20, 7
TIMA0_C1N	O	TIMA0 capture/compare 1 complementary output	10, 14, 18, 25, 33, 38, 42, 45	A2, B3, C6, D2, D6, E2, F5, F6	10, 14, 22, 27, 30	14, 18, 25, 33, 38, 42, 45, 9	10, 14, 18, 25, 33, 38, 42, 45	14, 14, 18, 25, 33, 38, 42, 45	11, 15, 21, 28, 8	14, 21, 7, 9	14, 20, 9	12, 18, 7
TIMA0_C2N	O	TIMA0 capture/compare 2 complementary output	12, 19, 20, 26, 28, 31, 35, 37, 41, 8	A4, C1, D1, E4, E5, E7, F2, F4, G3, G6	15, 16, 18, 25, 26, 8	12, 19, 20, 26, 28, 31, 36, 37, 41, 8	12, 19, 20, 26, 28, 31, 36, 37, 41, 8	10, 15, 17, 20, 24, 6	13, 16, 19, 23, 9	10, 12, 16, 5	10, 11, 12, 16, 8	10, 14, 6, 9

**Table 6-13. Timer (TIMx) Signal Descriptions (continued)**

SIGNAL NAME	PIN TYPE	DESCRIPTION	PT (A) PIN	ZCM PIN	VFC PIN	PT (B) PIN	RGZ PIN	RHB PIN	DGS2 8 PIN	RGE PIN	DGS2 0 PIN	RUK PIN
TIMA0_C3N	O	TIMA0 capture/compare 3 complementary output	15, 16, 20, 27, 28, 33, 44, 46, 5, 8	A4, B4, B7, C2, C4, C7, D1, F5, G2, G3	11, 12, 16, 18, 22, 29, 31	15, 16, 20, 27, 28, 33, 4, 44, 46	15, 16, 20, 27, 28, 33, 44, 46, 5, 8	12, 16, 17, 22, 28, 30, 6	1, 21, 27, 9	14, 20, 22, 5	1, 14, 19, 8	12, 17, 19, 6, 8
TIMA_FAL0	I	TIMA fault input 0	12, 15, 16, 19, 24, 3, 46, 8	A4, B5, B7, C1, C2, C4, E4, G1	11, 12, 15, 3, 31, 8	12, 15, 16, 19, 24, 3, 46	12, 15, 16, 19, 24, 3, 46, 8	10, 12, 15, 30, 6	1, 13, 16, 9	10, 22, 5	1, 10, 11, 8	19, 6, 8, 9
TIMA_FAL1	I	TIMA fault input 1	1, 11, 17, 18, 35, 41, 8	A4, B1, D2, D3, D4, E7, G6	13, 14, 25, 7	1, 11, 17, 18, 36, 41	1, 11, 17, 18, 35, 41, 8	1, 13, 14, 24, 6, 9	12, 14, 15, 23, 4, 9	16, 24, 5, 8, 9	16, 4, 8	14, 2, 6
TIMA_FAL2	I	TIMA fault input 2	16, 2, 20, 24, 33, 45, 47	A7, C4, C5, C6, D1, F5, G1	12, 16, 2, 22, 30, 32	16, 2, 20, 24, 33, 45, 47	16, 2, 20, 24, 33, 45, 47	12, 2, 22, 29, 31	2, 21, 28, 5	1, 14, 21	14, 2, 20, 5	12, 18, 20, 3
TIMG8_IDX	I	TIMG8 quadrature encoder index pulse signal	13, 2, 24, 30, 38, 48, 8	A4, B2, C5, D5, F6, G1, G4	1, 2, 20, 9	13, 2, 24, 30, 38, 48, 8	13, 2, 24, 30, 38, 48, 8	11, 19, 2, 32, 6	18, 3, 5, 9	1, 11, 23, 5	3, 5, 8	1, 3, 6
TIMG14_C0	IO	TIMG14 capture/compare 0 signal	1, 11, 18, 27, 34, 36, 43, 45	B1, B6, C6, D2, D4, D7, G2, G7	14, 24, 28, 30, 7	1, 11, 18, 27, 35, 43, 45	1, 11, 18, 27, 34, 36, 43, 45	1, 14, 16, 23, 27, 29, 9	12, 15, 22, 26, 28, 4	15, 19, 21, 24, 9	15, 18, 20, 4	13, 16, 18, 2
TIMG14_C1	IO	TIMG14 capture/compare 1 signal	12, 19, 2, 28, 30, 35, 37, 44	C1, C5, C7, E4, E5, G3, G4, G6	15, 18, 2, 20, 25, 26, 29, 8	12, 19, 2, 28, 30, 36, 37, 44	12, 19, 2, 28, 30, 35, 37, 44	10, 15, 17, 19, 2, 24, 28	13, 16, 18, 23, 27, 5	1, 10, 11, 16, 20	10, 11, 16, 19, 5	14, 17, 3, 9
TIMG14_C2	IO	TIMG14 capture/compare 2 signal	24, 31, 42, 48	D5, D6, F4, G1	1, 27	24, 31, 42, 48	24, 31, 42, 48	20, 32	19, 3	12, 23	12, 3	1, 10

**Table 6-13. Timer (TIMx) Signal Descriptions (continued)**

SIGNAL NAME	PIN TYPE	DESCRIPTION	PT (A) PIN	ZCM PIN	VFC PIN	PT (B) PIN	RGZ PIN	RHB PIN	DGS2 8 PIN	RGE PIN	DGS2 0 PIN	RUK PIN
TIMG14_C3	IO	TIMG14 capture/compare 3 signal	28	G3	18	28	28	17				
TIMG1_C0	IO	TIMG1 capture/compare 0 signal	11, 13, 14, 20, 22, 29, 36, 39, 45	B1, B2, B3, C6, D1, E6, F1, F3, G7	10, 16, 19, 30, 7, 9	11, 13, 14, 20, 22, 29, 39, 45	11, 13, 14, 20, 22, 29, 36, 39, 45	11, 18, 25, 29, 9	12, 17, 24, 28	17, 21	20	18
TIMG1_C1	IO	TIMG1 capture/compare 1 signal	12, 15, 17, 21, 23, 37, 40, 46	B7, C1, C2, D3, E1, E3, E5, F7	11, 13, 17, 26, 31, 8	12, 15, 17, 21, 23, 37, 40, 46	12, 15, 17, 21, 23, 37, 40, 46	10, 13, 26, 30	1, 13, 14, 25	18, 22, 8	1, 10, 17	15, 19, 8
TIMG2_C0	IO	TIMG2 capture/compare 0 signal	17, 23, 25, 3, 32, 43, 46, 9	A3, B5, B7, D3, D7, E2, E3, G5	13, 21, 28, 3, 31	17, 23, 25, 3, 32, 43, 46, 8	17, 23, 25, 3, 32, 43, 46, 9	13, 21, 27, 30, 7	1, 10, 14, 20, 26	13, 19, 22, 6, 8	1, 13, 18	11, 16, 19
TIMG2_C1	IO	TIMG2 capture/compare 1 signal	10, 13, 15, 16, 18, 24, 25, 26, 27, 33, 38, 44, 47, 48, 8	A2, A4, A7, B2, C2, C4, C7, D2, D5, E2, F2, F5, F6, G1, G2	1, 11, 12, 14, 22, 29, 32, 9	13, 15, 16, 18, 24, 25, 26, 27, 33, 38, 44, 47, 48, 9	10, 13, 15, 16, 18, 24, 25, 26, 27, 33, 38, 44, 47, 48, 8	11, 12, 14, 16, 22, 28, 31, 32, 6, 8	11, 15, 2, 21, 27, 3, 9	14, 20, 23, 5, 7, 9	14, 19, 2, 3, 8, 9	1, 12, 17, 20, 6, 7, 8
TIMG8_C0	IO	TIMG8 capture/compare 0 signal	11, 13, 2, 20, 22, 25, 32, 39, 43, 46, 9	A3, B1, B2, B7, C5, D1, D7, E2, E6, F1, G5	16, 2, 21, 28, 31, 7, 9	11, 13, 2, 20, 22, 25, 32, 39, 43, 46, 8	11, 13, 2, 20, 22, 25, 32, 39, 43, 46, 9	11, 2, 21, 25, 27, 30, 7, 9	1, 10, 12, 20, 24, 26, 5	1, 13, 17, 19, 22, 6	1, 13, 18, 5	11, 16, 19, 3

**Table 6-13. Timer (TIMx) Signal Descriptions (continued)**

SIGNAL NAME	PIN TYPE	DESCRIPTION	PT (A) PIN	ZCM PIN	VFC PIN	PT (B) PIN	RGZ PIN	RHB PIN	DGS2 8 PIN	RGE PIN	DGS2 0 PIN	RUK PIN
TIMG8_C1	IO	TIMG8 capture/compare 1 signal	1, 10, 12, 18, 20, 21, 26, 28, 33, 38, 40, 41, 44, 47, 8	A2, A4, A7, C1, C7, D1, D2, D4, E1, E7, F2, F5, F6, F7, G3	14, 16, 17, 18, 21, 22, 29, 32, 8	1, 12, 18, 20, 21, 26, 28, 33, 38, 40, 41, 44, 47, 9	1, 10, 12, 18, 20, 21, 26, 28, 33, 40, 41, 44, 47, 8	1, 10, 14, 17, 22, 26, 28, 31, 6, 8	11, 13, 15, 2, 21, 24, 5, 7, 9	14, 18, 20, 24, 5	10, 14, 17, 19, 2, 4, 8, 9	12, 15, 17, 2, 20, 6, 7

**Table 6-14. Universal Asynchronous Receiver Transmitter (UART) Signal Descriptions**

SIGNAL NAME	PIN TYPE	DESCRIPTION	PT (A) PIN	ZCM PIN	VFC PIN	PT (B) PIN	RGZ PIN	RHB PIN	DGS2 8 PIN	RGE PIN	DGS2 0 PIN	RUK PIN
UART0_CTS	I	UART0 clear to send signal	11, 17, 29, 34, 38, 43	B1, B6, D3, D7, F3, F6	13, 19, 24, 28, 7	11, 17, 29, 35, 38, 43	11, 17, 29, 34, 38, 43	13, 18, 23, 27, 9	12, 14, 17, 22, 26	15, 19, 8	15, 18	13, 16
UART0_RTS	O	UART0 ready to send signal	12, 16, 30, 35, 37, 42, 44	C1, C4, C7, D6, E5, G4, G6	12, 20, 23, 25, 26, 27, 29, 8	12, 16, 30, 34, 36, 37, 42, 44	12, 16, 30, 35, 37, 42, 44	10, 12, 19, 24, 28	13, 18, 23, 27	11, 16, 20	10, 16, 19	14, 17
UART0_RX	IO	UART0 receive signal (RXD)	19, 2, 21, 22, 23, 28, 32, 46, 48, 5	B4, B7, C5, D5, E1, E3, E4, F1, G3, G5	1, 15, 17, 18, 2, 21, 31	19, 2, 21, 22, 23, 28, 32, 4, 46, 48	19, 2, 21, 22, 23, 28, 32, 4, 46, 48	15, 17, 2, 21, 30, 32	1, 16, 20, 3, 5	1, 10, 13, 22, 23	1, 11, 13, 3, 5	1, 11, 19, 3, 9
UART0_TX	O	UART0 transmit signal (TXD)	1, 18, 2, 20, 23, 24, 29, 3, 43, 45, 47	A7, B5, C5, C6, D1, D2, D4, D7, E3, F3, G1	14, 16, 19, 2, 28, 3, 30, 32	1, 18, 2, 20, 23, 24, 29, 3, 43, 45, 47	1, 18, 2, 20, 23, 24, 29, 3, 43, 45, 47	1, 14, 18, 2, 27, 29, 31	15, 17, 2, 26, 28, 4, 5	1, 19, 21, 24, 9	18, 2, 20, 4, 5	16, 18, 2, 20, 3

**Table 6-14. Universal Asynchronous Receiver Transmitter (UART) Signal Descriptions (continued)**

SIGNAL NAME	PIN TYPE	DESCRIPTION	PT (A) PIN	ZCM PIN	VFC PIN	PT (B) PIN	RGZ PIN	RHB PIN	DGS2 8 PIN	RGE PIN	DGS2 0 PIN	RUK PIN
UART1_CTS	I	UART1 clear to send signal	14, 22, 27, 39, 41, 46, 47	A7, B3, B7, E6, E7, F1, G2	10, 31, 32	14, 22, 27, 39, 41, 46, 47	14, 22, 27, 39, 41, 46, 47	16, 25, 30, 31	1, 2, 24	17, 22	1, 2	19, 20
UART1_RTS	O	UART1 ready to send signal	15, 2, 23, 28, 33, 40, 48	C2, C5, D5, E3, F5, F7, G3	1, 11, 18, 2, 22	15, 2, 23, 28, 33, 40, 48	15, 2, 23, 28, 33, 40, 48	17, 2, 22, 26, 32	21, 25, 3, 5	1, 14, 18, 23	14, 17, 3, 5	1, 12, 15, 3, 8
UART1_RX	I	UART1 receive signal (RXD)	10, 12, 14, 16, 17, 19, 21, 26, 33, 34, 35, 40, 44	A2, B3, B6, C1, C4, C7, D3, E1, E4, F2, F5, F7, G6	10, 12, 13, 15, 17, 22, 24, 25, 29, 8	12, 14, 16, 17, 19, 21, 26, 33, 35, 36, 40, 44, 9	10, 12, 14, 16, 17, 19, 21, 26, 33, 35, 36, 40, 44	10, 12, 13, 14, 15, 22, 23, 24, 26, 28, 8	11, 13, 14, 16, 21, 22, 25, 27	10, 14, 15, 16, 18, 20, 7, 8	10, 11, 14, 15, 16, 17, 19, 9	12, 13, 14, 15, 16, 17, 7, 9
UART1_TX	O	UART1 transmit signal (TXD)	11, 13, 15, 16, 20, 25, 32, 35, 9	A3, B1, B2, C2, C4, D1, E2, G5, G6	11, 12, 16, 21, 25, 7, 9	11, 13, 15, 16, 20, 25, 32, 36, 8	11, 13, 15, 16, 20, 25, 32, 35, 9	11, 12, 15, 16, 20, 24, 7, 9	10, 12, 20, 23	13, 16, 6	13, 16	11, 14, 8
UART2_CTS	I	UART2 clear to send signal	14, 20, 27, 31, 38, 39, 45, 9	A3, B3, C6, D1, E6, F4, F6, G2	10, 16, 30	14, 20, 27, 31, 38, 39, 45, 8	14, 20, 27, 31, 38, 39, 45, 9	16, 20, 25, 29, 7	10, 19, 24, 28	12, 17, 21, 6	12, 20	10, 18
UART2_RTS	O	UART2 ready to send signal	10, 15, 21, 30, 41, 42, 46	A2, B7, C2, D6, E1, E7, G4	11, 17, 20, 27, 31	15, 21, 30, 41, 42, 46, 9	10, 15, 21, 30, 41, 42, 46	19, 30, 8	1, 11, 18	11, 22, 7	1, 9	19, 7, 8
UART2_RX	I	UART2 receive signal (RXD)	15, 26, 29, 37, 38, 39, 40, 44	C2, C7, E5, E6, F2, F3, F6, F7	11, 19, 26, 29	15, 26, 29, 37, 38, 39, 40, 44	15, 26, 29, 37, 38, 39, 40, 44	18, 25, 26, 28	17, 24, 25, 27	17, 18, 20	17, 19	15, 17, 8

**Table 6-14. Universal Asynchronous Receiver Transmitter (UART) Signal Descriptions (continued)**

SIGNAL NAME	PIN TYPE	DESCRIPTION	PT (A) PIN	ZCM PIN	VFC PIN	PT (B) PIN	RGZ PIN	RHB PIN	DGS2 8 PIN	RGE PIN	DGS2 0 PIN	RUK PIN
UART2_TX	O	UART2 transmit signal (TXD)	14, 25, 28, 36, 39, 40, 43	B3, D7, E2, E6, F7, G3, G7	10, 18, 28	14, 25, 28, 39, 40, 43	14, 25, 28, 36, 39, 40, 43	17, 25, 26, 27	24, 25, 26	17, 18, 19	17, 18	15, 16

## 6.4 Connections for Unused Pins

Table 6-15 lists the correct termination of unused pins.

**Table 6-15. Connection of Unused Pins**

PIN <sup>(1)</sup>	POTENTIAL	COMMENT
PAx and PBx	Open	Set corresponding pin functions to GPIO (PINCMx.PF = 0x1) and configure unused pins to output low or input with internal pullup/pulldown resistor.
NRST	VCC	NRST is an active-low reset signal; it must be pulled high to VCC or the device will not start, for more information refer to <a href="#">Section 9.1</a>

- (1) Any unused pin with a function that is shared with general-purpose I/O should follow the "PAx and PBx" unused pin connection guidelines.

## 7 Specifications

### 7.1 Absolute Maximum Ratings

over operating free-air temperature range (unless otherwise noted)<sup>(1)</sup>

			MIN	MAX	UNIT
V <sub>DD</sub>	Supply voltage	At VDD pin, with respect to VSS	-0.3	4.1	V
V <sub>I</sub>	Input voltage	Applied to any 5-V tolerant open-drain pins	-0.3	5.5	V
V <sub>I</sub>	Input voltage	Applied to any common tolerance pins	-0.3	V <sub>DD</sub> + 0.3 (4.1 MAX)	V
I <sub>VDD</sub> <sup>(3)</sup>	Current into VDD pin (source)	-40°C ≤ T <sub>j</sub> ≤ 130°C		80	mA
		-40°C ≤ T <sub>j</sub> ≤ 85°C		100	mA
I <sub>VSS</sub> <sup>(3)</sup>	Current out of VSS pin (sink)	-40°C ≤ T <sub>j</sub> ≤ 130°C		80	mA
		-40°C ≤ T <sub>j</sub> ≤ 85°C		100	mA
I <sub>IO</sub>	Current for SDIO pin	Current sunk or sourced by SDIO pin		6	mA
	Current for ODIO pin	Current sunk by ODIO pin		20	mA
I <sub>D</sub>	Supported diode current	Diode current at any device pin		±2	mA
T <sub>j</sub>	Junction temperature		-40	130	°C
T <sub>stg</sub>	Storage temperature <sup>(2)</sup>		-40	150	°C

- (1) Stresses beyond those listed under *Absolute Maximum Rating* may cause permanent damage to the device. These are stress ratings only, which do not imply functional operation of the device at these or any other conditions beyond those indicated under *Recommended Operating Condition*. Exposure to absolute-maximum-rated conditions for extended periods may affect device reliability.
- (2) Higher temperatures may be applied during board soldering according to the current JEDEC J-STD-020 specification with peak reflow temperatures not higher than classified on the device label on the shipping boxes or reels.
- (3) For applications operating at VDD=1.62V, I<sub>VDD</sub>/I<sub>VSS</sub>≤20mA is required to ensure device functionality

### 7.2 ESD Ratings

			VALUE	UNIT
V <sub>(ESD)</sub>	Electrostatic discharge	Human body model (HBM), per ANSI/ESDA/ JEDEC JS-001, all pins <sup>(1)</sup>	±2000	V
		Charged device model (CDM), per JEDEC specification JESD22-C101, all pins <sup>(2)</sup>	±500	

- (1) JEDEC document JEP155 states that 500-V HBM allows safe manufacturing with a standard ESD control process.
- (2) JEDEC document JEP157 states that 250-V CDM allows safe manufacturing with a standard ESD control process.

### 7.3 Recommended Operating Conditions

over operating free-air temperature range (unless otherwise noted)

		MIN	NOM	MAX	UNIT
V <sub>DD</sub>	Supply voltage <sup>(3)</sup>	1.62 <sup>(4)</sup>		3.6	V
C <sub>VDD</sub>	Capacitor placed between VDD and VSS <sup>(1)</sup>		10		uF
T <sub>A</sub>	Ambient temperature	-40		125	°C
T <sub>J</sub>	Max junction temperature			130	°C
f <sub>MCLK</sub>	MCLK, CPUCLK, ULPCLK frequency with 1 flash wait state <sup>(2)</sup>			32	MHz
	MCLK, CPUCLK, ULPCLK frequency with 0 flash wait states <sup>(2)</sup>			24	

- (1) Connect C<sub>VDD</sub> between VDD/VSS as close to the device pins as possible. A low-ESR capacitor with at least the specified value and tolerance of ±20% or better is required for C<sub>VDD</sub>.
- (2) Wait states are managed automatically by the system controller (SYSCTL) and do not need to be configured by application software.
- (3) There is no dependency on MCLK frequency with respect to VDD recommended operating range.
- (4) Functionality is guaranteed down to V<sub>BOR0-(max)</sub>.

## 7.4 Thermal Information

THERMAL METRIC <sup>(1)</sup>		PACKAGE	VALUE	UNIT
$R_{\theta JA}$	Junction-to-ambient thermal resistance	LQFP-48 (PT)	78.8	°C/W
$R_{\theta JC(top)}$	Junction-to-case (top) thermal resistance		35.1	°C/W
$R_{\theta JB}$	Junction-to-board thermal resistance		50.7	°C/W
$\Psi_{JT}$	Junction-to-top characterization parameter		3.5	°C/W
$\Psi_{JB}$	Junction-to-board characterization parameter		50.1	°C/W
$R_{\theta JC(bot)}$	Junction-to-case (bottom) thermal resistance		N/A	°C/W
$R_{\theta JA}$	Junction-to-ambient thermal resistance	VQFN-48 (RGZ)	34.6	°C/W
$R_{\theta JC(top)}$	Junction-to-case (top) thermal resistance		25.4	°C/W
$R_{\theta JB}$	Junction-to-board thermal resistance		17.5	°C/W
$\Psi_{JT}$	Junction-to-top characterization parameter		1.6	°C/W
$\Psi_{JB}$	Junction-to-board characterization parameter		17.5	°C/W
$R_{\theta JC(bot)}$	Junction-to-case (bottom) thermal resistance		9.0	°C/W
$R_{\theta JA}$	Junction-to-ambient thermal resistance	NFBGA-48 (ZCM)	101.1	°C/W
$R_{\theta JC(top)}$	Junction-to-case (top) thermal resistance		42.1	°C/W
$R_{\theta JB}$	Junction-to-board thermal resistance		62.2	°C/W
$\Psi_{JT}$	Junction-to-top characterization parameter		1.8	°C/W
$\Psi_{JB}$	Junction-to-board characterization parameter		62.0	°C/W
$R_{\theta JC(bot)}$	Junction-to-case (bottom) thermal resistance		N/A	°C/W
$R_{\theta JA}$	Junction-to-ambient thermal resistance	VQFN-32 (RHB)	38.7	°C/W
$R_{\theta JC(top)}$	Junction-to-case (top) thermal resistance		31.1	°C/W
$R_{\theta JB}$	Junction-to-board thermal resistance		18.7	°C/W
$\Psi_{JT}$	Junction-to-top characterization parameter		1.6	°C/W
$\Psi_{JB}$	Junction-to-board characterization parameter		18.7	°C/W
$R_{\theta JC(bot)}$	Junction-to-case (bottom) thermal resistance		9.1	°C/W
$R_{\theta JA}$	Junction-to-ambient thermal resistance	VSSOP-28 (DGS28)	80.6	°C/W
$R_{\theta JC(top)}$	Junction-to-case (top) thermal resistance		39.9	°C/W
$R_{\theta JB}$	Junction-to-board thermal resistance		42.6	°C/W
$\Psi_{JT}$	Junction-to-top characterization parameter		3.5	°C/W
$\Psi_{JB}$	Junction-to-board characterization parameter		42.2	°C/W
$R_{\theta JC(bot)}$	Junction-to-case (bottom) thermal resistance		N/A	°C/W
$R_{\theta JA}$	Junction-to-ambient thermal resistance	VQFN-24 (RGE)	47.1	°C/W
$R_{\theta JC(top)}$	Junction-to-case (top) thermal resistance		40.4	°C/W
$R_{\theta JB}$	Junction-to-board thermal resistance		23.7	°C/W
$\Psi_{JT}$	Junction-to-top characterization parameter		2.4	°C/W
$\Psi_{JB}$	Junction-to-board characterization parameter		23.6	°C/W
$R_{\theta JC(bot)}$	Junction-to-case (bottom) thermal resistance		9.3	°C/W
$R_{\theta JA}$	Junction-to-ambient thermal resistance	VSSOP-20 (DGS20)	92.8	°C/W
$R_{\theta JC(top)}$	Junction-to-case (top) thermal resistance		35.5	°C/W
$R_{\theta JB}$	Junction-to-board thermal resistance		49.6	°C/W
$\Psi_{JT}$	Junction-to-top characterization parameter		1.3	°C/W
$\Psi_{JB}$	Junction-to-board characterization parameter		49.1	°C/W
$R_{\theta JC(bot)}$	Junction-to-case (bottom) thermal resistance		N/A	°C/W

THERMAL METRIC <sup>(1)</sup>		PACKAGE	VALUE	UNIT
$R_{\theta JA}$	Junction-to-ambient thermal resistance	WQFN-20 (RUK)	49.6	°C/W
$R_{\theta JC(top)}$	Junction-to-case (top) thermal resistance		48.9	°C/W
$R_{\theta JB}$	Junction-to-board thermal resistance		23.6	°C/W
$\Psi_{JT}$	Junction-to-top characterization parameter		1.4	°C/W
$\Psi_{JB}$	Junction-to-board characterization parameter		23.6	°C/W
$R_{\theta JC(bot)}$	Junction-to-case (bottom) thermal resistance		9.2	°C/W

- (1) For more information about traditional and new thermal metrics, see the [Semiconductor and IC Package Thermal Metrics](#) application report.

## 7.5 Supply Current Characteristics

### 7.5.1 RUN/SLEEP Modes

VDD=3.3V. All inputs tied to 0V or VDD. Outputs do not source or sink any current. All peripherals are disabled.

PARAMETER		MCLK	-40°C		25°C		85°C		105°C		125°C		UNIT
			TYP	MAX	TYP	MAX	TYP	MAX	TYP	MAX	TYP	MAX	
<b>RUN Mode</b>													
IDDRUN	MCLK=SYSOSC, CoreMark, execute from flash	32MHz	2.9		2.9		2.9		2.9		2.9		mA
IDDRUN, per MHz	MCLK=SYSOSC, While(1), execute from flash	32MHz	52	58	53	59	53	59	54	60	54	60	uA/MHz
	MCLK=SYSOSC, CoreMark, execute from flash		90		91		91		91		91		
<b>SLEEP Mode</b>													
IDDSLEEP	MCLK=SYSOSC, CPU is halted	32MHz	1332	1455	1346	1468	1358	1479	1362	1486	1370	1490	uA
IDDSLEEP	MCLK=LFCLK, CPU is halted	32kHz	524	591	529	595	542	643	549	650	558	660	uA

### 7.5.2 STOP/STANDBY Modes

VDD=3.3V unless otherwise noted. All inputs tied to 0V or VDD. Outputs do not source or sink any current. All peripherals not noted are disabled.

PARAMETER		ULPCLK	-40°C		25°C		85°C		105°C		125°C		UNIT
			TYP	MAX	TYP	MAX	TYP	MAX	TYP	MAX	TYP	MAX	
<b>STOP Mode</b>													
IDDSTOP0	SYSOSC=32MHz, DISABLESTOP=0	4MHz	415	456	422	459	431	473	434	476	436	481	uA
IDDSTOP2	SYSOSC off, DISABLESTOP=1, ULPCLK=LFCLK	32kHz	81	91	84	93	93	118	96	121	99	127	
<b>STANDBY Mode</b>													
IDDSTBY0	LFXT and RTC enabled		2.6	4.1	2.7	4.1	7.9	27	11	30	16	34	uA
	LFOSC and IWDT enabled		2.4	3.8	2.5	3.8	7.6	27	10	30	13	35	uA
	LFXT and RTC enabled, IWDT enabled		2.6	4.1	2.7	4.1	8.0	27	11	30	16	34	uA
	STOPCLKSTBY=0, TIMG0 enabled	32kHz	2.3	3.9	2.4	3.9	7.6	27	10	29	15	35	uA
STOPCLKSTBY=1, TIMG0 enabled	2.1		3.4	2.2	3.4	7.1	26	10	29	15	34		
STOPCLKSTBY=1, GPIOA enabled	2.0		2.6	2.1	2.6	7.1	26	10	29	13	34		

### 7.5.3 SHUTDOWN Mode

VDD=3.3V unless otherwise noted. All inputs tied to 0V or VDD. Outputs do not source or sink any current. Core regulator is powered down.

PARAMETER		-40°C		25°C		85°C		105°C		125°C		UNIT
		TYP	MAX	TYP	MAX	TYP	MAX	TYP	MAX	TYP	MAX	
IDDSHDN	Supply current in SHUTDOWN mode	54		68		255		524		1362		nA

## 7.6 Power Supply Sequencing

### 7.6.1 Power Supply Ramp

Figure 7-1 gives the relationship of POR-, POR+, BOR0-, and BOR0+ during power-up and power-down.

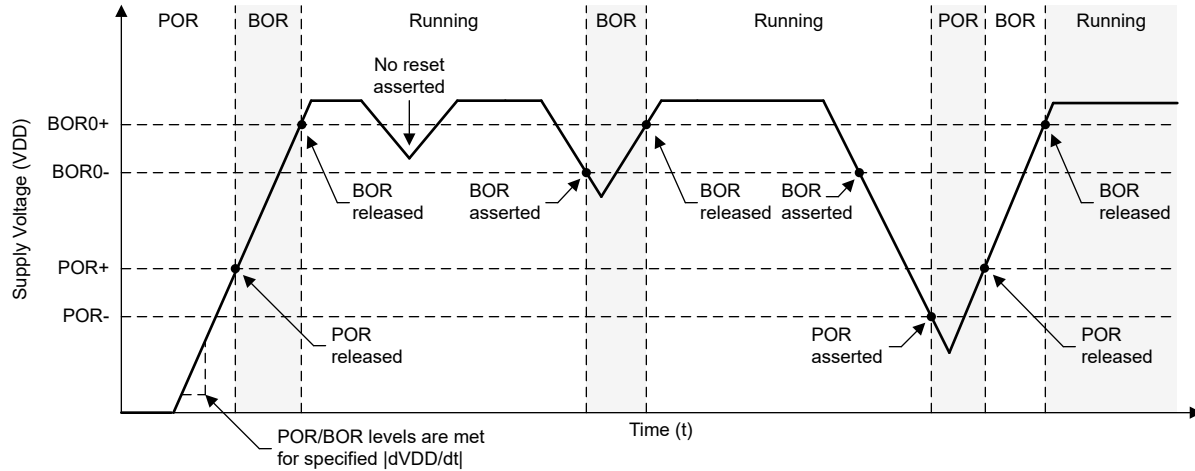

Figure 7-1. Power Cycle POR/BOR Conditions - VDD

### 7.6.2 POR and BOR

over operating free-air temperature range (unless otherwise noted)

PARAMETER		TEST CONDITIONS	MIN	TYP	MAX	UNIT
dVDD/dt	VDD (supply voltage) slew rate	Rising			0.1	V/us
		Falling <sup>(1)</sup>			0.01	
		Falling, STANDBY			0.1	V/ms
V <sub>POR+</sub>	Power-on reset voltage level	Rising	0.95	1.3	1.59	V
V <sub>POR-</sub>		Falling	0.9	1.25	1.54	V
V <sub>HYS, POR</sub>	POR hysteresis		30	58	74	mV
V <sub>BOR0+, COLD</sub>	Brown-out reset voltage level 0 (default level)	-40 °C ≤ Ta ≤ 25 °C, Cold start, rising	1.50	1.56	1.63	V
		25 °C ≤ Ta ≤ 125 °C, Cold start, rising	1.51	1.58	1.65	
V <sub>BOR0+</sub>		Rising <sup>(1)</sup>	1.56	1.59	1.62	
V <sub>BOR0-</sub>		Falling <sup>(1)</sup>	1.55	1.58	1.61	
V <sub>BOR0, STBY</sub>		STANDBY mode	1.51	1.56	1.61	
V <sub>BOR1+</sub>	Brown-out-reset voltage level 1	Rising <sup>(1)</sup>	2.13	2.17	2.21	V
V <sub>BOR1-</sub>		Falling <sup>(1)</sup>	2.10	2.14	2.18	
V <sub>BOR1, STBY</sub>		STANDBY mode	2.06	2.13	2.20	
V <sub>BOR2+</sub>	Brown-out-reset voltage level 2	Rising <sup>(1)</sup>	2.73	2.77	2.82	V
V <sub>BOR2-</sub>		Falling <sup>(1)</sup>	2.7	2.74	2.79	
V <sub>BOR2, STBY</sub>		STANDBY mode	2.62	2.71	2.8	
V <sub>BOR3+</sub>	Brown-out-reset voltage level 3	Rising <sup>(1)</sup>	2.88	2.96	3.04	V
V <sub>BOR3-</sub>		Falling <sup>(1)</sup>	2.85	2.93	3.01	
V <sub>BOR3, STBY</sub>		STANDBY mode	2.82	2.92	3.02	
V <sub>HYS, BOR</sub>	Brown-out reset hysteresis	Level 0		15	21	mV
		Levels 1-3		34	40	
T <sub>PD, BOR</sub>	BOR propagation delay	RUN/SLEEP/STOP mode			5	us
		STANDBY mode			100	us

(1) Device operating in RUN, SLEEP, or STOP mode.

## 7.7 Flash Memory Characteristics

over operating free-air temperature range (unless otherwise noted)

PARAMETER		TEST CONDITIONS	MIN	TYP	MAX	UNIT
<b>Supply</b>						
VDD <sub>PGM/ERASE</sub>	Program and erase supply voltage		1.62		3.6	V
IDDERASE	Supply current from VDD during erase operation	Supply current delta		2		mA
IDDPGM	Supply current from VDD during program operation	Supply current delta		2.5		mA
<b>Endurance</b>						
NWEC <sub>(LOWER)</sub>	Erase/program cycle endurance (lower 32kB flash) <sup>(1)</sup>		100			k cycles
NWEC <sub>(UPPER)</sub>	Erase/program cycle endurance (remaining flash) <sup>(1)</sup>		10			k cycles
NE <sub>(MAX)</sub>	Total erase operations before failure <sup>(2)</sup>		802			k erase operations
NW <sub>(MAX)</sub>	Write operations per word line before sector erase <sup>(3)</sup>				83	write operations
<b>Retention</b>						
t <sub>RET_85</sub>	Flash memory data retention	-40°C ≤ T <sub>j</sub> ≤ 85°C	60			years
t <sub>RET_105</sub>	Flash memory data retention	-40°C ≤ T <sub>j</sub> ≤ 105°C	11.4			years
<b>Program and Erase Timing</b>						
t <sub>PROG (WORD, 64)</sub>	Program time for flash word <sup>(4) (6)</sup>			50	275	μs
t <sub>PROG (SEC, 64)</sub>	Program time for 1kB sector <sup>(5) (6)</sup>			6.4		ms
t <sub>ERASE (SEC)</sub>	Sector erase time	≤2k erase/program cycles, T <sub>j</sub> ≥ 25°C		4	20	ms
t <sub>ERASE (SEC)</sub>	Sector erase time	≤10k erase/program cycles, T <sub>j</sub> ≥ 25°C		20	150	ms
t <sub>ERASE (SEC)</sub>	Sector erase time	≤10k erase/program cycles		20	200	ms
t <sub>ERASE (BANK)</sub>	Bank erase time	≤10k erase/program cycles		22	220	ms

- (1) The lower 32kB flash address space supports higher erase/program endurance to enable EEPROM emulation applications. On devices with ≤32kB flash memory, the entire flash memory supports NWEC<sub>(LOWER)</sub> erase/program cycles.
- (2) Total number of cumulative erase operations supported by the flash before failure. A sector erase or bank erase operation is considered to be one erase operation.
- (3) Maximum number of write operations allowed per word line before the word line must be erased. If additional writes to the same word line are required, a sector erase is required once the maximum number of write operations per word line is reached.
- (4) Program time is defined as the time from when the program command is triggered until the command completion interrupt flag is set in the flash controller.
- (5) Sector program time is defined as the time from when the first word program command is triggered until the final word program command completes and the interrupt flag is set in the flash controller. This time includes the time needed for software to load each flash word (after the first flash word) into the flash controller during programming of the sector.
- (6) Flash word size is 64 data bits (8 bytes). On devices with ECC, the total flash word size is 72 bits (64 data bits plus 8 ECC bits).

## 7.8 Timing Characteristics

VDD=3.3V, T<sub>a</sub>=25 °C (unless otherwise noted)

PARAMETER		TEST CONDITIONS	MIN	TYP	MAX	UNIT
<b>Wakeup Timing</b>						
t <sub>WAKE, SLEEP</sub>	Wakeup time from SLEEP to RUN <sup>(1)</sup>			2		cycles
t <sub>WAKE, STOP0</sub>	Wakeup time from STOP0 to RUN (SYSOSC enabled) <sup>(1)</sup>			14		us
t <sub>WAKE, STOP2</sub>	Wakeup time from STOP2 to RUN (SYSOSC disabled) <sup>(1)</sup>			13		us

VDD=3.3V, T<sub>a</sub>=25 °C (unless otherwise noted)

PARAMETER		TEST CONDITIONS	MIN	TYP	MAX	UNIT
t <sub>WAKE, STBY0</sub>	Wakeup time from STANDBY to RUN (1)			15		us
t <sub>WAKE, SHDN</sub>	Wakeup time from SHUTDOWN to RUN	Fast boot enabled		255		us
t <sub>WAKE, SHDN</sub>	Wakeup time from SHUTDOWN to RUN	Fast boot disabled		265		us
<b>Asynchronous Fast Clock Request Timing</b>						
t <sub>DELAY</sub>	Delay time from edge of asynchronous request to first 32MHz MCLK edge	Mode is SLEEP2		0.9		us
t <sub>DELAY</sub>	Delay time from edge of asynchronous request to first 32MHz MCLK edge	Mode is STOP0		2.4		us
t <sub>DELAY</sub>	Delay time from edge of asynchronous request to first 32MHz MCLK edge	Mode is STOP2		0.9		us
t <sub>DELAY</sub>	Delay time from edge of asynchronous request to first 32MHz MCLK edge	Mode is STANDBY1		3.2		us
<b>Startup Timing</b>						
t <sub>START, RESET</sub>	Device cold start-up time from reset/power-up (2)	Fast boot enabled		241		us
		Fast boot disabled		284		us
<b>NRST Timing</b>						
t <sub>RST, BOOTRST</sub>	Minimum pulse length on NRST pin to generate BOOTRST	ULPCLK≥4MHz		2		us
		ULPCLK=32kHz		100		us
t <sub>RST, POR</sub>	Minimum pulse length on NRST pin to generate POR			1		s

- (1) The wake-up time is measured from the edge of an external signal (GPIO wake-up event) to the time that the first CPU instruction is executed, with the GPIO glitch filter disabled (FILTEREN=0x0) and fast wake enabled (FASTWAKEONLY=1)
- (2) The start-up time is measured from the time that VDD crosses VBOR0+ (cold start-up) to the time that the first instruction of the user program is executed.

## 7.9 Clock Specifications

### 7.9.1 System Oscillator (SYSOSC)

over operating free-air temperature range (unless otherwise noted)

PARAMETER		TEST CONDITIONS	MIN	TYP	MAX	UNIT
f <sub>SYSOSC</sub>	Factory trimmed SYSOSC frequency	SYSOSCCFG.FREQ=00 (BASE)		32		MHz
f <sub>SYSOSC</sub>	SYSOSC frequency accuracy when frequency correction loop (FCL) is enabled (1) (2)	SETUSEFCL=1, T <sub>a</sub> = 25 °C	0		1.0	%
		SETUSEFCL=1, -40 °C ≤ T <sub>a</sub> ≤ 125 °C	-2.1		1.6	
f <sub>SYSOSC</sub>	SYSOSC accuracy when frequency correction loop (FCL) is disabled, 32MHz (1) (2)	SETUSEFCL=0, SYSOSCCFG.FREQ=00, -40 °C ≤ T <sub>a</sub> ≤ 125 °C	-2.6		1.8	%
t <sub>settle, SYSOSC</sub>	Settling time to target accuracy (3)	SETUSEFCL=1			30	us

- (1) SYSOSC accuracy is measured in the default power-up state, with MCLK = SYSOSC and the CPU running a while(1) loop.
- (2) SYSOSC is measured with the internal FCC counter using an external 1ms pulse as the measurement trigger.
- (3) When SYSOSC is waking up (for example, when exiting a low power mode) and FCL is enabled, the SYSOSC will initially undershoot the target frequency f<sub>SYSOSC</sub> by an additional error of up to t<sub>settle, SYSOSC</sub> for the time t<sub>settle, SYSOSC</sub>, after which the target accuracy is achieved.

### 7.9.2 Low Frequency Oscillator (LFOSC)

over operating free-air temperature range (unless otherwise noted)

PARAMETER		TEST CONDITIONS	MIN	TYP	MAX	UNIT
f <sub>LFOSC</sub>	LFOSC frequency			32768		Hz
	LFOSC accuracy	-40 °C ≤ T <sub>a</sub> ≤ 125 °C	-5		5	%
		-40 °C ≤ T <sub>a</sub> ≤ 85 °C	-3		3	%
I <sub>LFOSC</sub>	LFOSC current consumption			300		nA
t <sub>start, LFOSC</sub>	LFOSC start-up time			1		ms

### 7.9.3 Low Frequency Crystal/Clock

over operating free-air temperature range (unless otherwise noted)

PARAMETER		TEST CONDITIONS	MIN	TYP	MAX	UNIT
<b>Low frequency crystal oscillator (LFXT)</b>						
f <sub>LFXT</sub>	LFXT frequency			32768		Hz
DC <sub>LFXT</sub>	LFXT duty cycle		30		70	%
OA <sub>LFXT</sub>	LFXT crystal oscillation allowance			419		kΩ
C <sub>L, eff</sub>	Integrated effective load capacitance <sup>(1)</sup>			1		pF
t <sub>start, LFXT</sub>	LFXT start-up time			1000		ms
I <sub>LFXT</sub>	LFXT current consumption	XT1DRIVE=0, LOWCAP=1		300		nA
<b>Low frequency digital clock input (LFCLK_IN)</b>						
f <sub>LFIN</sub>	LFCLK_IN frequency <sup>(2)</sup>	SETUSEEXLF=1	29491	32768	36045	Hz
DC <sub>LFIN</sub>	LFCLK_IN duty cycle <sup>(2)</sup>	SETUSEEXLF=1	40		60	%
<b>LFCLK Monitor</b>						
f <sub>FAULTLF</sub>	LFCLK monitor fault frequency <sup>(3)</sup>	MONITOR=1	2800	4200	8400	Hz

- (1) This includes parasitic bond and package capacitance (≈2pF per pin), calculated as  $C_{LFXIN} \times C_{LFXOUT} / (C_{LFXIN} + C_{LFXOUT})$ , where  $C_{LFXIN}$  and  $C_{LFXOUT}$  are the total capacitance at LFXIN and LFXOUT, respectively.
- (2) The digital clock input (LFCLK\_IN) accepts a logic level square wave clock.
- (3) The LFCLK monitor may be used to monitor the LFXT or LFCLK\_IN. It will always fault below the MIN fault frequency, and will never fault above the MAX fault frequency.

### 7.9.4 High Frequency Crystal/Clock

over operating free-air temperature range (unless otherwise noted)

PARAMETER		TEST CONDITIONS	MIN	TYP	MAX	UNIT
<b>High frequency crystal oscillator (HFXT)</b>						
f <sub>HFXT</sub>	HFXT frequency	HFXTSEL=00	4		8	MHz
f <sub>HFXT</sub>	HFXT frequency	HFXTSEL=01	8.01		16	MHz
f <sub>HFXT</sub>	HFXT frequency	HFXTSEL=10	16.01		32	MHz
DC <sub>HFXT</sub>	HFXT duty cycle	HFXTSEL=00	40		65	%
DC <sub>HFXT</sub>	HFXT duty cycle	HFXTSEL=01	40		60	%
DC <sub>HFXT</sub>	HFXT duty cycle	HFXTSEL=10	40		60	%
OA <sub>HFXT</sub>	HFXT crystal oscillation allowance	HFXTSEL=00 (4 to 8MHz range)		2		kΩ
C <sub>L, eff</sub>	Integrated effective load capacitance <sup>(1)</sup>			1		pF
t <sub>start, HFXT</sub>	HFXT start-up time <sup>(2)</sup>	HFXTSEL=11, 32MHz crystal		0.5		ms

over operating free-air temperature range (unless otherwise noted)

PARAMETER		TEST CONDITIONS	MIN	TYP	MAX	UNIT
$I_{HFXT}$	HFXT current consumption <sup>(2)</sup>	$f_{HFXT}=4\text{MHz}$ , $R_m=300\Omega$ , $C_L=12\text{pF}$		100		$\mu\text{A}$
$I_{HFXT}$	HFXT current consumption <sup>(2)</sup>	$f_{HFXT}=32\text{MHz}$ , $R_m=30\Omega$ , $C_L=12\text{pF}$ , $C_m=6.26\text{fF}$ , $L_m=1.76\text{mH}$		600		$\mu\text{A}$
<b>High frequency digital clock input (HFCLK_IN)</b>						
$f_{HFIN}$	HFCLK_IN frequency <sup>(3)</sup>	USEEXTHFCLK =1	4		32	MHz
$DC_{HFIN}$	HFCLK_IN duty cycle <sup>(3)</sup>	USEEXTHFCLK =1	40		60	%

- (1) This includes parasitic bond and package capacitance ( $\approx 2\text{pF}$  per pin), calculated as  $C_{HF\text{XIN}} \times C_{HF\text{XOUT}} / (C_{HF\text{XIN}} + C_{HF\text{XOUT}})$ , where  $C_{HF\text{XIN}}$  and  $C_{HF\text{XOUT}}$  are the total capacitance at HF $\text{XIN}$  and HF $\text{XOUT}$ , respectively.
- (2) The HFXT startup time ( $t_{\text{start, HFXT}}$ ) is measured from the time the HFXT is enabled until stable oscillation for a typical crystal. Start-up time is dependent upon crystal frequency and crystal specifications. Current consumption increases with higher RSEL and start up time is decreases with higher RSEL.
- (3) The digital clock input (HFCLK\_IN) accepts a logic level square wave clock.

## 7.10 Digital IO

### 7.10.1 Electrical Characteristics

over recommended ranges of supply voltage and operating free-air temperature (unless otherwise noted)

PARAMETER		TEST CONDITIONS		MIN	TYP	MAX	UNIT
$V_{IH}$	High level input voltage	ODIO <sup>(1)</sup>	$V_{DD} \geq 1.62\text{V}$	$0.7 \times V_{DD}$		5.5	V
			$V_{DD} \geq 2.7\text{V}$	2		5.5	V
		All I/O except ODIO & Reset	$V_{DD} \geq 1.62\text{V}$	$0.7 \times V_{DD}$		$V_{DD} + 0.3$	V
$V_{IL}$	Low level input voltage	ODIO	$V_{DD} \geq 1.62\text{V}$	-0.3		$0.3 \times V_{DD}$	V
			$V_{DD} \geq 2.7\text{V}$	-0.3		0.8	V
		All I/O except ODIO & Reset	$V_{DD} \geq 1.62\text{V}$	-0.3		$0.3 \times V_{DD}$	V
$V_{HYS}$	Hysteresis	ODIO		$0.05 \times V_{DD}$			V
		All I/O except ODIO		$0.1 \times V_{DD}$			V
$I_{kg}$	High-Z leakage current	SDIO <sup>(2) (3)</sup>				$50^{(4)}$	nA
$R_{PU}$	Pull up resistance	All I/O except ODIO			40		k $\Omega$
$R_{PD}$	Pull down resistance				40		k $\Omega$
$C_i$	Input capacitance				5		pF
$V_{OL}$	Low level output voltage	SDIO	$V_{DD} \geq 2.7\text{V}$ , $ I_{OL,max}  = 6\text{mA}$ $V_{DD} \geq 1.71\text{V}$ , $ I_{OL,max}  = 2\text{mA}$			0.4	V
		ODIO	$V_{DD} \geq 2.7\text{V}$ , $I_{OL,max} = 8\text{mA}$ $V_{DD} \geq 1.71\text{V}$ , $I_{OL,max} = 4\text{mA}$			0.5	
$V_{OH}$	High level output voltage	SDIO	$V_{DD} \geq 2.7\text{V}$ , $I_{OH,max} = 6\text{mA}$	$V_{DD} - 0.5$			V
			$V_{DD} \geq 1.71\text{V}$ , $I_{OH,max} = 2\text{mA}$	$V_{DD} - 0.4$			V

- (1) I/O Types: ODIO = 5V Tolerant Open-Drain, SDIO = Standard-Drive
- (2) The leakage current is measured with VSS or VDD applied to the corresponding pin(s), unless otherwise noted.
- (3) The leakage of the digital port pins is measured individually. The port pin is selected for input and the pullup/pulldown resistor is disabled.

- (4) This value is for SDIO not muxed with any analog inputs. If the SDIO is muxed with analog inputs then the leakage can be as high as 100nA.

### 7.10.2 Switching Characteristics

over recommended ranges of supply voltage and operating free-air temperature (unless otherwise noted)

PARAMETER		TEST CONDITIONS		MIN	TYP	MAX	UNIT
f <sub>max</sub>	Port output frequency	SDIO <sup>(1)</sup>	VDD ≥ 1.71V, C <sub>L</sub> = 20pF			16	MHz
			VDD ≥ 2.7V, C <sub>L</sub> = 20pF			32	
		ODIO	VDD ≥ 1.71V, FM <sup>+</sup> , CL = 20pF - 100pF			1	
t <sub>r</sub> , t <sub>f</sub>	Output rise/fall time	SDIO	VDD ≥ 1.71V, C <sub>L</sub> = 20pF			3.5	ns
t <sub>r</sub> , t <sub>f</sub>	Output rise/fall time	SDIO	VDD ≥ 2.7V, C <sub>L</sub> = 20pF			6.6	ns
t <sub>f</sub>	Output fall time	ODIO	VDD ≥ 1.71V, FM <sup>+</sup> , CL = 20pF-100pF	20*VDD/5.5		120	ns

- (1) I/O Types: ODIO = 5V Tolerant Open-Drain , SDIO = Standard-Drive

### 7.11 Analog Mux VBOOST

over operating free-air temperature range (unless otherwise noted)

PARAMETER		TEST CONDITIONS	MIN	TYP	MAX	UNIT
I <sub>VBST</sub>	VBOOST current adder	MCLK/ULPCLK is LFCLK		0.8		uA
		MCLK/ULPCLK is not LFCLK, SYSOSC frequency is 32MHz		20		
t <sub>START,VBST</sub>	VBOOST startup time			12		us

### 7.12 ADC

#### 7.12.1 Electrical Characteristics

over recommended ranges of supply voltage and operating free-air temperature (unless otherwise noted), all TYP values are measured at 25°C and all accuracy parameters are measured using 12-bit resolution mode (unless otherwise noted)

PARAMETER		TEST CONDITIONS	MIN	TYP	MAX	UNIT
V <sub>in(ADC)</sub>	Analog input voltage range <sup>(1)</sup>	Applies to all ADC analog input pins	0		VDD	V
V <sub>R+</sub>	Positive ADC reference voltage	V <sub>R+</sub> sourced from VDD		VDD		V
		V <sub>R+</sub> sourced from external reference pin (VREF+)	1.4		VDD	V
		V <sub>R+</sub> sourced from internal reference (VREF)		VREF		V
V <sub>R-</sub>	Negative ADC reference voltage			0		V
F <sub>S</sub>	ADC sampling frequency	RES = 0x0 (12-bit mode), External Reference			1.6	MSPS
F <sub>S</sub>	ADC sampling frequency	RES = 0x1 (10-bit mode), External Reference			1.7	MSPS
F <sub>S</sub>	ADC sampling frequency	RES = 0x2 (8-bit mode), External Reference			1.9	MSPS
I <sub>(ADC)</sub>	Operating supply current into VDD terminal	F <sub>S</sub> = 1.6MSPS, External reference, V <sub>R+</sub> = VDD		350		μA
		F <sub>S</sub> = 500ksps, Internal reference, V <sub>R+</sub> = VREF = 2.5V		300		
C <sub>S/H</sub>	ADC sample-and-hold capacitance			0.22		pF
R <sub>in</sub>	ADC sampling switch resistance			15		kΩ
ENOB	Effective number of bits	Internal reference, V <sub>R+</sub> = VREF = 2.5V, F <sub>in</sub> = 10KHz	9.4	10.2		bit
		External reference, F <sub>in</sub> = 10KHz <sup>(2)</sup>	10	10.6		
ENOB	Effective number of bits	External reference, hardware averaging enabled (16 samples), F <sub>in</sub> = 10KHz <sup>(2)</sup>		11.8		bit
SNR	Signal-to-noise ratio	External reference <sup>(2)</sup>		67		dB
		Internal reference, V <sub>R+</sub> = VREF = 2.5V		64		
SNR	Signal-to-noise ratio	External reference <sup>(2)</sup> , hardware averaging enabled (16 samples)		75		dB

over recommended ranges of supply voltage and operating free-air temperature (unless otherwise noted), all TYP values are measured at 25°C and all accuracy parameters are measured using 12-bit resolution mode (unless otherwise noted)

PARAMETER		TEST CONDITIONS	MIN	TYP	MAX	UNIT
PSRR <sub>DC</sub>	Power supply rejection ratio, DC	External reference <sup>(2)</sup> , VDD = VDD <sub>(min)</sub> to VDD <sub>(max)</sub>		68		dB
		VDD = VDD <sub>(min)</sub> to VDD <sub>(max)</sub> Internal reference, V <sub>R+</sub> = VREF = 2.5V		61		
PSRR <sub>AC</sub>	Power supply rejection ratio, AC	External reference <sup>(2)</sup> , ΔVDD = 0.1 V at 1 kHz		61		dB
		ΔVDD = 0.1 V at 1 kHz Internal reference, V <sub>R+</sub> = VREF = 2.5V		49		
T <sub>wakeup</sub>	ADC Wakeup Time	Assumes internal reference is active			5	us
V <sub>SupplyMon</sub>	Supply Monitor voltage divider (VDD/3) accuracy	ADC input channel: Supply Monitor <sup>(3)</sup>	-1.5		+1.5	%
I <sub>SupplyMon</sub>	Supply Monitor voltage divider current consumption	ADC input channel: Supply Monitor		10		uA

- (1) The analog input voltage range must be within the selected ADC reference voltage range V<sub>R+</sub> to V<sub>R-</sub> for valid conversion results.
- (2) All external reference specifications are measured with V<sub>R+</sub> = VREF+ = VDD = 3.3V and V<sub>R-</sub> = VREF- = VSS = 0V and external 1uF cap on VREF+ pin
- (3) Analog power supply monitor. Analog input on channel 15 is disconnected and is internally connected to the voltage divider which is VDD/3.

### 7.12.2 Switching Characteristics

over recommended ranges of supply voltage and operating free-air temperature (unless otherwise noted)

PARAMETER		TEST CONDITIONS	MIN	TYP	MAX	UNIT
f <sub>ADCCLK</sub>	ADC clock frequency		4		32	MHz
t <sub>ADC trigger</sub>	Software trigger minimum width		3			ADCCLK cycles
t <sub>Sample_step</sub>	Sampling time for step input	12-bit mode, R <sub>S</sub> = 50Ω, C <sub>pext</sub> = 10pF	0.188			μs
t <sub>Sample_VREF</sub>	Sample time with internal VREF input	ADC CHANNEL=29, 12-bit mode, VDD as reference	10			μs
t <sub>Sample_SupplyMon</sub>	Sample time with Supply Monitor (VDD/3)	12-bit mode	5			μs

### 7.12.3 Linearity Parameters

over recommended ranges of supply voltage and operating free-air temperature (unless otherwise noted), all TYP values are measured at 25°C and all linearity parameters are measured using 12-bit resolution mode (unless otherwise noted)

PARAMETER		TEST CONDITIONS	MIN	TYP	MAX	UNIT
E <sub>I</sub>	Integral linearity error (INL)	External reference <sup>(1)</sup>	-2.0		+2.0	LSB
E <sub>D</sub>	Differential linearity error (DNL) Guaranteed no missing codes	External reference, 12-bit <sup>(1)</sup>	-1.0		+1.0	LSB
E <sub>O</sub>	Offset error	External reference <sup>(1)</sup>	-5		5	mV
E <sub>G</sub>	Gain error	External reference <sup>(1)</sup>	-6		6	LSB

- (1) All external reference specifications are measured with V<sub>R+</sub> = VREF+ = VDD = 3.3V and V<sub>R-</sub> = VREF- = VSS = 0V and external 1uF cap on VREF+ pin

### 7.12.4 Typical Connection Diagram

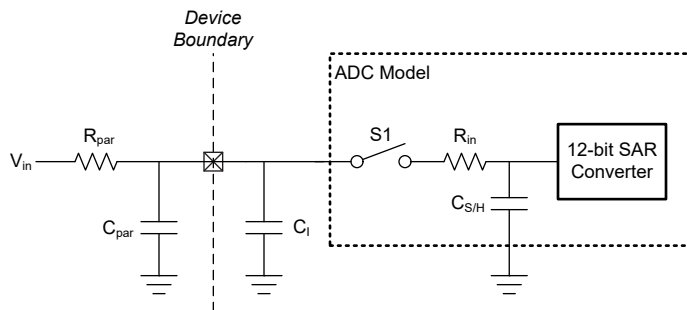

**Figure 7-2. ADC Input Network**

1. Refer to [Electrical Characteristics](#) for the values of  $R_{in}$  and  $C_{S/H}$
2. Refer to [Electrical Characteristics](#) for the value of  $C_I$
3.  $C_{par}$  and  $R_{par}$  represent the parasitic capacitance and resistance of the external ADC input circuitry

Use the following equations to solve for the minimum sampling time (T) required for an ADC conversion:

1.  $\tau = (R_{par} + R_{in}) * C_{S/H} + R_{par} * (C_{par} + C_I)$
2.  $K = \ln(2^n / \text{Settling error}) - \ln((C_{par} + C_I) / C_{S/H})$
3.  $T \text{ (Min sampling time)} = K * \tau$

### 7.13 Temperature Sensor

over operating free-air temperature range (unless otherwise noted)

PARAMETER		TEST CONDITIONS	MIN	TYP	MAX	UNIT
$TS_{TRIM}$	Factory trim temperature <sup>(1)</sup>	ADC and VREF configuration: RES=0 (12-bit mode), VRSEL=2h (internal VREF), BUFCONFIG=1h (1.4V VREF), ADC $t_{sample}=10\mu s$	27	30	33	°C
$TS_C$	Temperature coefficient		-2.05	-1.89	-1.75	mV/°C
$t_{SET, TS}$	Temperature sensor settling time <sup>(2)</sup>			2.5	10	us

- (1) Higher absolute accuracy may be achieved through user calibration.
- (2) This is the maximum time required for the temperature sensor to settle when measured by the ADC. It may be used to specify the minimum ADC sample time when measuring the temperature sensor.

## 7.14 VREF

### 7.14.1 Electrical Characteristics

over recommended ranges of supply voltage and operating free-air temperature (unless otherwise noted)

PARAMETER		TEST CONDITIONS	MIN	TYP	MAX	UNIT
$I_{VREF}$	VREF operating supply current	BUFCONFIG = {0, 1}, No load		80	100	$\mu$ A
$TC_{VREF}$	Temperature coefficient of VREF <sup>(1)</sup>	BUFCONFIG = {0, 1}			75	ppm/°C
$TC_{drift}$	Long term VREF drift	Time = 1000 hours, BUFCONFIG = {0, 1}, T = 25°C			300	ppm
$PSRR_{DC}$	VREF Power supply rejection ratio, DC	VDD = 1.7 V to VDDmax, BUFCONFIG = 1	60	70		dB
		VDD = 2.7 V to VDDmax, BUFCONFIG = 0	49	60		
$V_{noise}$	RMS noise at VREF output (0.1 Hz to 100 MHz)	BUFFCONFIG = 1		500		$\mu$ Vrms
		BUFFCONFIG = 0		900		
ADC $F_S$	Max supported ADC sampling frequency	Using VREF as ADC reference			515	ksps
$T_{startup}$	VREF startup time	BUFCONFIG = {0, 1}, VDD = 2.8 V			30	us

(1) The temperature coefficient of the VREF output is the sum of  $TC_{VRBUF}$  and the temperature coefficient of the internal bandgap reference.

### 7.14.2 Voltage Characteristics

over recommended ranges of supply voltage and operating free-air temperature (unless otherwise noted)

PARAMETER		TEST CONDITIONS	MIN	TYP	MAX	UNIT
$VDD_{min}$	Minimum supply voltage needed for VREF operation	BUFCONFIG = 1	1.62			V
		BUFCONFIG = 0	2.7			
VREF	Voltage reference output voltage	BUFCONFIG = 1	1.38	1.4	1.42	V
		BUFCONFIG = 0	2.46	2.5	2.54	

## 7.15 Comparator (COMP)

### 7.15.1 Comparator Electrical Characteristics

over recommended ranges of supply voltage and operating free-air temperature (unless otherwise noted)

PARAMETER		TEST CONDITIONS	MIN	TYP	MAX	UNIT
<b>Comparator Electrical Characteristics</b>						
$V_{cm}$	Common mode input range		0		VDD	V
$V_{offset}$	Input offset voltage		-20		20	mV
$V_{hys}$	DC input hysteresis	HYST=00h		0.4		mV
		HYST=01h		10		
		HYST=02h		20		
		HYST=03h		30		
$t_{PD\_ls}$	Propagation delay, response time	Output Filter off, Overdrive = 100 mV, High Speed Mode		32	50	ns
		Output Filter off, Overdrive = 100 mV, Low Power Mode		1.2	4	$\mu$ s
$t_{en}$	Comparator enable time	Startup time to reach propagation delay specification, High Speed Mode			5	$\mu$ s
		Startup time to reach propagation delay specification, Low Power Mode			10	$\mu$ s

over recommended ranges of supply voltage and operating free-air temperature (unless otherwise noted)

PARAMETER		TEST CONDITIONS	MIN	TYP	MAX	UNIT
$I_{comp}$	Comparator current consumption.	V <sub>cm</sub> = VDD/2, 100mV overdrive, DAC output as a voltage reference, VDD is reference for DAC, High Speed Mode		130	200	μA
		V <sub>cm</sub> = VDD/2, 100mV overdrive, DAC output as a voltage reference, VDD is reference for DAC, Low Power Mode		0.85	2.7	μA
		V <sub>cm</sub> = VDD/2, 100mV overdrive, comparator only, High Speed Mode		120	180	μA
		V <sub>cm</sub> = VDD/2, 100mV overdrive, comparator only, Low Power Mode		0.7	2.1	μA
<b>8-bit DAC Electrical Characteristics</b>						
V <sub>dac</sub>	DAC output range		0		VDD	V
V <sub>dac-code</sub>	8-bit DAC output voltage for a given code	V <sub>IN</sub> = reference voltage into 8-bit DAC, code n = 0 to 255		$V_{IN} \times (n+1) / 256$		V
INL	Integral nonlinearity of 8-bit DAC		-1		1	LSB
DNL	Differential nonlinearity of 8-bit DAC		-1		1	LSB
Gain error	Gain error of 8-bit DAC	Reference voltage = VDD	-2		2	% of FSR
Offset error	Offset error of 8-bit DAC		-5		5	mV
Output Impedance	8-bit DAC output impedance			50		kΩ
t <sub>dac_settle</sub>	8-bit DAC settling time in static mode	DACCODE0 = 0 → 255, DAC output accurate to 1 LSB, DAC output on pin PA11, Cload = 15pF		6		μs
t <sub>dac_settle</sub>	8-bit DAC settling time in static mode	DACCODE0 = 0 → 255, DAC output accurate to 1 LSB		1.5		μs

## 7.16 I2C

### 7.16.1 I2C Characteristics

over operating free-air temperature range (unless otherwise noted)

PARAMETERS		TEST CONDITIONS	Standard mode		Fast mode		Fast mode plus		UNIT
			MIN	MAX	MIN	MAX	MIN	MAX	
f <sub>I2C</sub>	I2C input clock frequency	I2C in Power Domain0	2	32	8	32	20	32	MHz
f <sub>SCL</sub>	SCL clock frequency			0.1		0.4		1	MHz
t <sub>HD,STA</sub>	Hold time (repeated) START		4		0.6		0.26		us
t <sub>LOW</sub>	Low period of the SCL clock		4.7		1.3		0.5		us
t <sub>HIGH</sub>	High period of the SCL clock		4		0.6		0.26		us
t <sub>SU,STA</sub>	Setup time for a repeated START		4.7		0.6		0.26		us
t <sub>HD,DAT</sub>	Data hold time		0		0		0		ns
t <sub>SU,DAT</sub>	Data setup time		250		100		50		ns
t <sub>SU,STO</sub>	Setup time for STOP		4		0.6		0.26		us
t <sub>BUF</sub>	Bus free time between a STOP and START condition		4.7		1.3		0.5		us
t <sub>VD,DAT</sub>	Data valid time			3.45		0.9		0.45	us
t <sub>VD,ACK</sub>	Data valid acknowledge time			3.45		0.9		0.45	us

### 7.16.2 I2C Filter

over operating free-air temperature range (unless otherwise noted)

PARAMETERS		TEST CONDITIONS	MIN	TYP	MAX	UNIT
f <sub>SP</sub>	Pulse duration of spikes suppressed by input filter	AGFSELx = 0		6		ns
		AGFSELx = 1		14	35	ns
		AGFSELx = 2		22	60	ns
		AGFSELx = 3		35	90	ns

### 7.16.3 I<sup>2</sup>C Timing Diagram

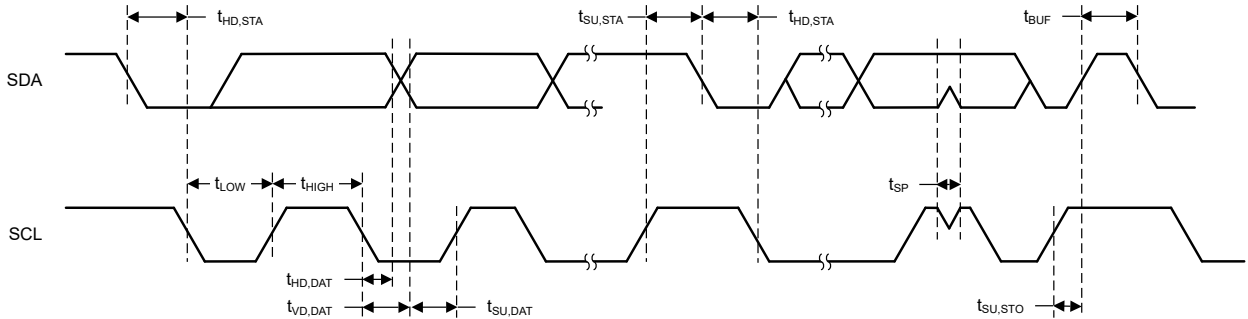

Figure 7-3. I2C Timing Diagram

## 7.17 SPI

### 7.17.1 SPI

over operating free-air temperature range (unless otherwise noted)

PARAMETERS		TEST CONDITIONS	MIN	TYP	MAX	UNIT
<b>SPI</b>						
f <sub>SPI</sub>	SPI clock frequency	Clock max speed = 32MHz 1.62 < VDD < 3.6V Controller mode			16	MHz
f <sub>SPI</sub>	SPI clock frequency	Clock max speed = 32MHz 1.62 < VDD < 3.6V Peripheral mode			16	MHz
DC <sub>SCK</sub>	SCK Duty Cycle		40	50	60	%
<b>Controller</b>						
t <sub>SCLK_H/L</sub>	SCLK High or Low time		(t <sub>SPI</sub> /2) - 1	t <sub>SPI</sub> / 2	(t <sub>SPI</sub> /2) + 1	ns
t <sub>CS.LEAD</sub>	CS lead-time, CS active to clock		1 SPI Clock			ns
t <sub>CS.LAG</sub>	CS lag time, Last clock to CS inactive		1 SPI Clock			ns
t <sub>CS.ACC</sub>	CS access time, CS active to PICO data out				1/2 SPI Clock	ns
t <sub>CS.DIS</sub>	CS disable time, CS inactive to PICO high impedance				1 SPI Clock	ns
t <sub>SU.CI</sub>	POCI input data setup time <sup>(1)</sup>	2.7 < VDD < 3.6V, delayed sampling enabled	1			ns
		1.62 < VDD < 2.7V, delayed sampling enabled	8			
t <sub>SU.CI</sub>	POCI input data setup time <sup>(1)</sup>	2.7 < VDD < 3.6V, no delayed sampling	30			ns
		1.62 < VDD < 2.7V, no delayed sampling	39			

over operating free-air temperature range (unless otherwise noted)

PARAMETERS		TEST CONDITIONS	MIN	TYP	MAX	UNIT
$t_{HD,CI}$	POCI input data hold time	No delayed sampling	0			ns
$t_{VALID,CO}$	PICO output data valid time <sup>(2)</sup>				16	ns
$t_{HD,CO}$	PICO output data hold time <sup>(3)</sup>		1			ns
<b>Peripheral</b>						
$t_{CS,LEAD}$	CS lead-time, CS active to clock		13.5			ns
$t_{CS,LAG}$	CS lag time, Last clock to CS inactive		1			ns
$t_{CS,ACC}$	CS access time, CS active to POCI data out				40	ns
$t_{CS,DIS}$	CS disable time, CS inactive to POCI high impedance				40	ns
$t_{SU,PI}$	PICO input data setup time		15			ns
$t_{HD,PI}$	PICO input data hold time		2.5			ns
$t_{VALID,PO}$	POCI output data valid time <sup>(2)</sup>	2.7 < VDD < 3.6V			31	ns
$t_{VALID,PO}$	POCI output data valid time <sup>(2)</sup>	1.62 < VDD < 2.7V			40	ns
$t_{HD,PO}$	POCI output data hold time <sup>(3)</sup>		5.5			ns

- (1) The POCI input data setup time can be fully compensated when delayed sampling feature is enabled.
- (2) Specifies the time to drive the next valid data to the output after the output changing SCLK clock edge
- (3) Specifies how long data on the output is valid after the output changing SCLK clock edge

### 7.17.2 SPI Timing Diagram

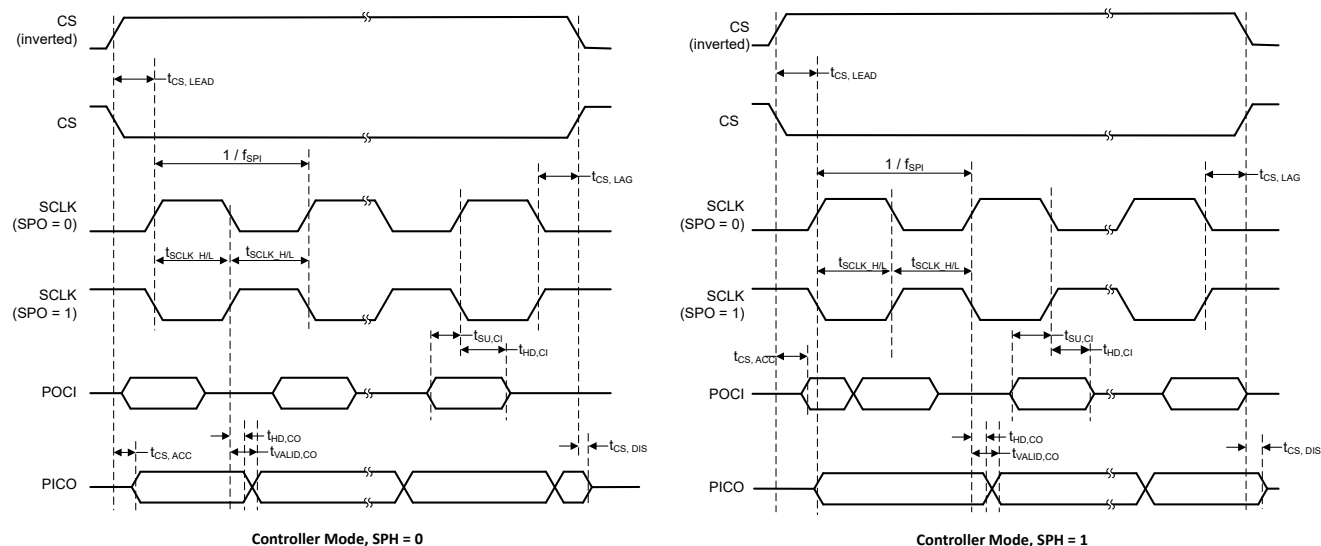
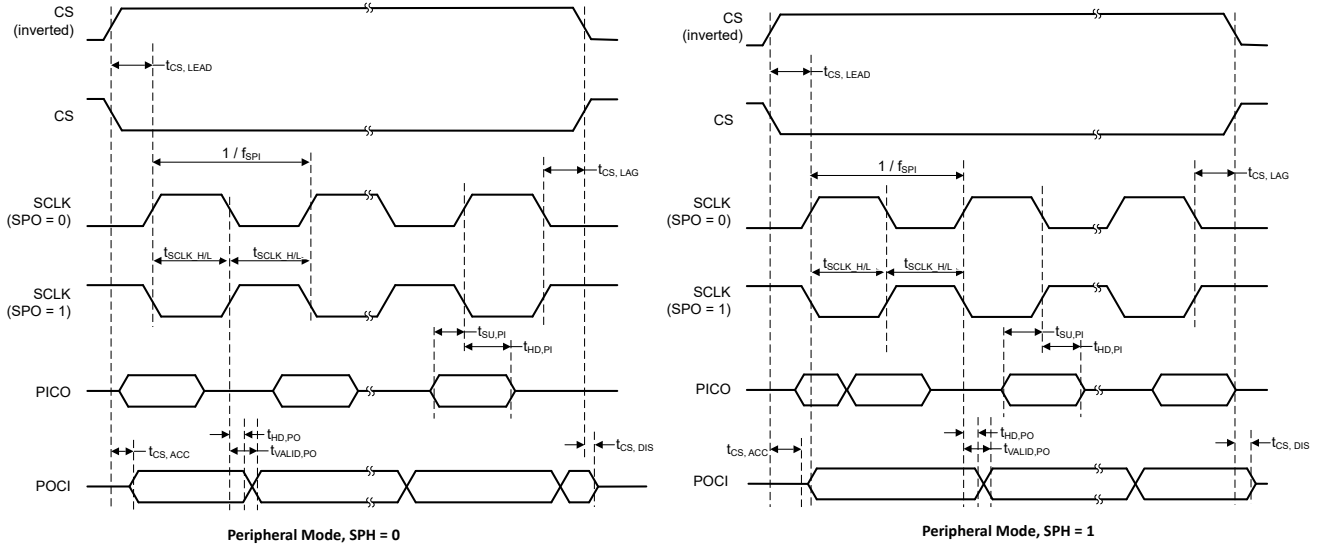

Figure 7-4. SPI Timing Diagram - Controller Mode



**Figure 7-5. SPI Timing Diagram - Peripheral Mode**

### 7.18 UART

over operating free-air temperature range (unless otherwise noted)

PARAMETERS		TEST CONDITIONS	MIN	TYP	MAX	UNIT
$f_{\text{UART}}$	UART input clock frequency				32	MHz
$f_{\text{BITCLK}}$	BITCLK clock frequency (equals baud rate in MBaud)				4	MHz
$t_{\text{SP}}$	Pulse duration of spikes suppressed by input filter	AGFSELx = 0		6		ns
		AGFSELx = 1		14	35	ns
		AGFSELx = 2		22	60	ns
		AGFSELx = 3		35	90	ns

### 7.19 TIMx

over operating free-air temperature range (unless otherwise noted)

PARAMETERS		TEST CONDITIONS	MIN	TYP	MAX	UNIT
$t_{\text{res}}$	Timer resolution time	$f_{\text{TIMxCLK}} = 64\text{MHz}$	15.625			ns
		$f_{\text{TIMxCLK}} = 32\text{MHz}$	31.25			ns
			1			$t_{\text{TIMxCLK}}$
$t_{\text{COUNTER}}$	16-bit counter clock period	$f_{\text{TIMxCLK}} = 64\text{MHz}$	0.01563		1024	us
		$f_{\text{TIMxCLK}} = 32\text{MHz}$	0.03125		2048	us
			1		65536	$t_{\text{TIMxCLK}}$

## 7.20 Emulation and Debug

### 7.20.1 SWD Timing

over operating free-air temperature range (unless otherwise noted)

PARAMETER	TEST CONDITIONS	MIN	TYP	MAX	UNIT
$f_{\text{SWD}}$	SWD frequency			10	MHz

## 8 Detailed Description

The following sections describe all of the components that make up the devices in this data sheet. The peripherals integrated into these devices are configured by software through Memory Mapped Registers (MMRs). For more details, see the corresponding chapter of the [MSPM0 C-Series Microcontrollers Technical Reference Manual](#).

## 8.1 Overview

MSPM0C1105/6 microcontrollers (MCUs) are part of MSP's highly integrated, ultra-low-power [32-bit MSPM0 MCU family](#) based on the Arm® Cortex®-M0+ 32-bit core platform, operating at up to 32MHz frequency. These cost-optimized MCUs offer high-performance analog peripheral integration, support extended temperature ranges from -40°C to 125°C, and operate with supply voltages from 1.62V to 3.6V.

The MSPM0C1105/6 devices provide up to 64KB embedded flash program memory with 8KB SRAM. These MCUs incorporate a high-speed on-chip oscillator with an accuracy from -2.1% to +1.6%, eliminating the need for an external crystal. Additional features include a 3-channel DMA, CRC-16 accelerator, and a variety of high-performance analog peripherals such as one 12-bit 1.6Msps ADC with VDD as the voltage reference, a comparator with 8-bit reference DAC and an on-chip temperature sensor. These devices also offer intelligent digital peripherals such as one 16-bit advanced timer with deadband and timer frequency up to 64MHz, four 16-bit general purpose timer, one windowed watchdog timer, and a variety of communication peripherals including three UART, one SPI, and two I2C. These communication peripherals offer protocol support for LIN, IrDA, DALI, Manchester, smart card, SMBus, and PMBus.

The TI MSPM0 family of low-power MCUs consists of devices with varying degrees of analog and digital integration allowing for customers find the MCU that meets their project's needs. The MSPM0 MCU platform combines the Arm Cortex-M0+ platform with a holistic ultra-low-power system architecture, allowing system designers to increase performance while reducing energy consumption.

For complete module descriptions, see the [MSPM0 C-Series Microcontrollers Technical Reference Manual](#).

## 8.2 CPU

The CPU subsystem (MCPUSS) implements an Arm Cortex-M0+ CPU, an instruction pre-fetch/cache, a system timer, and interrupt management features. The Arm Cortex-M0+ is a cost-optimized, 32-bit CPU which delivers high performance and low power to embedded applications. Key features of the CPU Sub System include:

- Arm Cortex-M0+ CPU supporting clock frequencies up to 32MHz
  - ARMv6-M Thumb instruction set (little endian) with 32-cycle 32x32 multiply instruction
- Pre-fetch logic to improve sequential code execution, and I-cache with two 64-bit cache lines
- System timer (SysTick) with 24-bit down counter and automatic reload
- Nested vectored interrupt controller (NVIC) with 4 programmable priority levels and tail-chaining

## 8.3 Operating Modes

MSPM0 MCUs provide five main operating modes (power modes) to allow for optimization of the device power consumption based on application requirements. In order of decreasing power, the modes are: RUN, SLEEP, STOP, STANDBY, and SHUTDOWN. The CPU is active executing code in RUN mode. Peripheral interrupt events can wake the device from SLEEP, STOP, or STANDBY mode to the RUN mode. SHUTDOWN mode completely disables the internal core regulator to minimize power consumption, and wake is only possible via NRST, SWD, or a logic level match on certain IOs. RUN, SLEEP, STOP, and STANDBY modes also include several configurable policy options (for example, RUN.x) for balancing performance with power consumption.

To further balance performance and power consumption, MSPM0 devices implement two power domains: **PD1** (for the CPU, memories, and high performance peripherals), and **PD0** (for low speed, low power peripherals).

- **PD1** is always powered in RUN and SLEEP modes, but is disabled in all other modes.
- **PD0** is always powered in RUN, SLEEP, STOP, and STANDBY modes.
- **PD1** and **PD0** are both disabled in SHUTDOWN mode.

### 8.3.1 Functionality by Operating Mode

Supported functionality in each operating mode is given in [Supported Functionality by Operating Mode](#).

Functional key:

- **EN**: The function is enabled in the specified mode.

- **DIS:** The function is disabled (either clock or power gated) in the specified mode, but the function's configuration is retained.
- **OPT:** The function is optional in the specified mode, and remains enabled if configured to be enabled.
- **NS:** The function is not automatically disabled in the specified mode but is not supported.
- **OFF:** The function is fully powered off in the specified mode, and no configuration information is retained. When waking up from an OFF state, all module registers must be re-configured to the desired settings by application software.

**Table 8-1. Supported Functionality by Operating Mode**

Operating Mode		RUN			SLEEP			STOP		STANDBY		SHUT OWN
		RUN0	RUN1	RUN2	SLEEP0	SLEEP1	SLEEP2	STOP0	STOP2	STANDBY0	STANDBY1	
Oscillators	SYSOSC	EN	EN	DIS	EN	EN	DIS	OPT <sup>(1)</sup>	DIS	DIS	DIS	OFF
	LFOSC or LFXT	EN										OFF
	HFXT	EN	DIS	DIS	OPT	DIS					OFF	
Clocks	CPUCLK	32M	32k	32k	DIS							OFF
	MCLK to PD1	32M	32k	32k	32M	32k	32k	DIS				OFF
	ULPCLK to PD0	32M	32k	32k	32M	32k	32k	4M <sup>(1)</sup>	32k	DIS	DIS	OFF
	ULPCLK to TIMG14/8	32M	32k	32k	32M	32k	32k	4M <sup>(1)</sup>	32k		DIS	OFF
	RTCCLK	32k										OFF
	MFCLK	OPT	DIS		OPT	DIS		OPT	DIS			OFF
	LFCLK	32k								DIS	DIS	OFF
	LFCLK to TIMG14/8	32k										OFF
	MCLK Monitor	OPT								DIS	DIS	OFF
	LFCLK Monitor	OPT										OFF
PMU	POR Monitor	EN										OFF
	BOR Monitor	EN										OFF
	Core Regulator	FULL DRIVE					REDUCED DRIVE		LOW DRIVE			OFF
Core Functions	CPU	EN			DIS							OFF
	DMA	OPT					NS (triggers supported)					OFF
	Flash	EN					OPT		DIS			OFF
	SRAM	EN					OPT		DIS			OFF
PD1 Peripherals	SPI0	OPT					DIS					OFF
	CRC	OPT					DIS					OFF
PD0 Peripherals	TIMG14/8	OPT										OFF
	TIMG1/2	OPT								DIS	DIS	OFF
	TIMA0	OPT								DIS	DIS	OFF
	UART0/1/2	OPT								DIS	DIS	OFF
	I2C0/1	OPT								DIS	DIS	OFF
	GPIOA/B	OPT								OPT <sup>(2)</sup>	DIS	OFF
	WWDT0	OPT								OPT <sup>(2)</sup>	DIS	OFF
	IWDT	OPT										OFF
RTC_B	OPT										OFF	

**Table 8-1. Supported Functionality by Operating Mode (continued)**

Operating Mode		RUN			SLEEP			STOP		STANDBY		SHUTD OWN
		RUN0	RUN1	RUN2	SLEEP0	SLEEP1	SLEEP2	STOP0	STOP2	STANDBY0	STANDBY1	
Analog	ADC0	OPT						NS (triggers supported)				OFF
	COMP	OPT										OFF
	VREF	OPT						NS				OFF
	Temperature Sensor	OPT								OFF		OFF
IOMUX and IO Wakeup		EN										DIS w/ WAKE
Wake Sources		N/A			ANY IRQ			PD0 IRQ				IOMUX, NRST, SWD

- (1) If STOP0 is entered from RUN1 (SYSOSC enabled but MCLK sourced from LFCLK), SYSOSC remains enabled as it was in RUN1, and ULPCCLK remains at 32kHz as it was in RUN1. If STOP0 is entered from RUN2 (SYSOSC was disabled and MCLK was sourced from LFCLK), SYSOSC remains disabled as it was in RUN2, and ULPCCLK remains at 32kHz as it was in RUN2.
- (2) When using the STANDBY1 policy for STANDBY, only specific peripherals (TIMG14, TIMG8, IWDG, and RTC) are clocked. Other PD0 peripherals can generate an asynchronous fast clock request upon external activity but are not actively clocked.

## 8.4 Power Management Unit (PMU)

The power management unit (PMU) generates the internally regulated core supplies for the device and provides supervision of the external supply (VDD). The PMU also contains the bandgap voltage reference used by the PMU itself as well as analog peripherals. Key features of the PMU include:

- Power-on reset (POR) supply monitor
- Brown-out reset (BOR) supply monitor with early warning capability using three programmable thresholds
- Core regulator with support for RUN, SLEEP, STOP, and STANDBY mode to dynamically balance performance with power consumption
- Parity-protected trim to immediately generate a power-on reset (POR) in the event that a power management trim is corrupted
- 4 bytes of shutdown memory

For more details, see the PMU chapter of the [MSPM0 C-Series Microcontrollers Technical Reference Manual](#).

## 8.5 Clock Module (CKM)

The clock module provides the following oscillators:

- **LFOSC**: Internal low-frequency oscillator (32kHz)
- **SYSOSC**: Internal high-frequency oscillator (32MHz with factory trim)
- **LFXT/LFCKIN** : low-frequency external crystal oscillator or digital clock input (32kHz)
- **HFXT/HFCKIN**: high-frequency external crystal oscillator or digital clock input (4MHz to 32MHz)

The following clocks are distributed by the clock module for use by the processor, bus, and peripherals:

- **MCLK**: Main system clock for PD1 peripherals, derived from SYSOSC, LFCLK, or HSCLK, active in RUN and SLEEP modes
- **CPUCLK**: Clock for the processor (derived from MCLK), active in RUN mode
- **ULPCLK**: Ultra-low power clock for PD0 peripherals, active in RUN, SLEEP, STOP, and STANDBY modes
- **MFCLK**: 4MHz fixed mid-frequency clock for peripherals, available in RUN, SLEEP, and STOP modes
- **LFCLK**: 32kHz fixed low-frequency clock for peripherals or MCLK, active in RUN, SLEEP, STOP, and STANDBY modes
- **ADCCLK**: ADC clock, available in RUN, SLEEP and STOP modes

- **RTCCLK**: Fixed 32kHz clock direct to RTC
- **CLK\_OUT**: Used to output a clock externally, available in RUN, SLEEP, STOP, and STANDBY modes
- **HFCLK**: High frequency clock derived from HFXT or HFCLK\_IN, available in RUN and SLEEP mode
- **HSCLK**: High speed clock derived from HFCLK, available in RUN and SLEEP mode

For more details, see the CKM chapter of the [MSPM0 C-Series Microcontrollers Technical Reference Manual](#).

## 8.6 DMA\_B

The direct memory access (DMA) controller allows movement of data from one memory address to another without CPU intervention. For example, the DMA can be used to move data from ADC conversion memory to SRAM. The DMA reduces system power consumption by allowing the CPU to remain in low power mode, without having to awaken to move data to or from a peripheral.

The DMA\_B in these devices support the following key features:

- 3 DMA transfer channel
  - 2 full-feature channels, supporting repeated transfer modes
  - 1 basic channel, supporting single transfer mode
- Configurable DMA channel priorities
- Direct peripheral to DMA trigger is supported from ADC, UART, SPI or timer triggers.
- Byte (8-bit), short word (16-bit) and word (32-bit) or mixed byte and word transfer capability
- Transfer counter block size supports up to 64k transfers of any data type
- Configurable DMA transfer trigger selection
- Active channel interruption to service other channels
- Early interrupt generation for ping-pong buffer architecture
- Cascading channels upon completion of activity on another channel
- Stride mode to support data re-organization, such as 3-phase metering applications
- Gather mode

[Table 8-2](#) shows the DMA features that are supported and the corresponding DMA channel numbers.

**Table 8-2. DMA\_B Channel Features**

DMA Feature	DMA_B	
	Full-Feature Channel	Basic Channel
Channel Number	0, 1	2
Repeated mode	✓	–
Table & fill mode	✓	–
Gather mode	✓	–
Early IRQ notification	✓	–
Auto enable	✓	✓
Long long (128-bit) transfer	✓	✓
Stride mode	✓	✓
Cascading channel support	✓	✓

[Table 8-3](#) lists the available triggers for the DMA which are configured using the DMATCTL.DMATSEL control bits in the DMA memory mapped registers.

**Table 8-3. DMA Trigger Mapping**

DMATCTL.DMATSEL	TRIGGER SOURCE
0	Software
1	Generic Subscriber 0 (FSUB_0)
2	Generic Subscriber 0 (FSUB_1)
3	I2C0 PUBLISHER 1
4	I2C0 PUBLISHER 2
5	I2C1 PUBLISHER 1

**Table 8-3. DMA Trigger Mapping (continued)**

DMACTL.DMATSEL	TRIGGER SOURCE
6	I2C1 PUBLISHER 2
7	SPI0 PUBLISHER 1
8	SPI0 PUBLISHER 2
9	UART0 PUBLISHER 1
10	UART0 PUBLISHER 2
11	UART1 PUBLISHER 1
12	UART1 PUBLISHER 2
13	UART2 PUBLISHER 1
14	UART2 PUBLISHER 2
15	ADC0 DMA Trigger

## 8.7 Events

The event manager transfers digital events from one entity (for example, a peripheral) to another (for example, a second peripheral, the DMA, or the CPU). The event manager implements event transfer through a defined set of event publishers (generators) and subscribers (receivers) which are interconnected through an event fabric containing a combination of static and programmable routes.

Events which are transferred by the event manager include:

- Peripheral event transferred to the CPU as an interrupt request (IRQ) (Static Event)
  - Example: RTC interrupt is sent to the CPU
- Peripheral event transferred to the DMA as a DMA trigger (DMA Event)
  - Example: UART data receive trigger to DMA to request a DMA transfer
- Peripheral event transferred to another peripheral to directly trigger an action in hardware (Generic Event)
  - Example: TIMx timer peripheral publishes a periodic event to the ADC subscriber port, and the ADC uses the event to trigger start-of-sampling

For more details, see the EVENT chapter of the [MSPM0 C-Series Microcontrollers Technical Reference Manual](#).

**Table 8-4. Generic Event Channels**

A generic route is either a point-to-point (1:1) route or a point-to-two (1:2) splitter route in which the peripheral publishing the event is configured to use one of several available generic route channels to publish its event to another entity (or entities, in the case of a splitter route), where an entity may be another peripheral, a generic DMA trigger event, or a generic CPU event.

CHANID	Generic Route Channel Selection	Channel Type
0	No generic event channel selected	N/A
1	Generic event channel 1 selected	1 : 1
2	Generic event channel 2 selected	1 : 1
3	Generic event channel 3 selected	1 : 1
4	Generic event channel 4 selected	1 : 1
6	Generic event channel 5 selected	1:1
7	Generic event channel 5 selected	1 : 2 (splitter)
8	Generic event channel 6 selected	1 : 2 (splitter)

## 8.8 Memory

### 8.8.1 Memory Organization

[Table 8-5](#) summarizes the memory map of the devices. For more information about the memory region detail, see the [Platform Memory Map](#) section in the [MSPM0 C-Series Microcontrollers Technical Reference Manual](#).

**Table 8-5. Memory Organization**

Memory Region	Subregion	MSPM0C1105	MSPM0C1106
Code (Flash)	Flash	32KB <sup>(1)</sup> 0x0000.0000 to 0x0000.7FFF	64KB <sup>(1)</sup> 0x0000.0000 to 0x0000.FFFF
SRAM (SRAM)	SRAM	8KB 0x2000.0000 to 0x2000.1FFF	8KB 0x2000.0000 to 0x2000.1FFF
Peripheral	Peripherals	0x4000.0000 to 0x40FF.FFFF	0x4000.0000 to 0x40FF.FFFF
	Flash	0x0040.0000 to 0x0040.7FFF	0x0040.0000 to 0x0040.9FFF
	Configuration NVM	512 bytes 0x41C0.0000 to 0x41C0.0200	512 bytes 0x41C0.0000 to 0x41C0.0200
	FACTORY	0x41C4.0000 to 0x41C4.0080	0x41C4.0000 to 0x41C4.0080
Subsystem		0x6000.0000 to 0x7FFF.FFFF	0x6000.0000 to 0x7FFF.FFFF
System PPB		0xE000.0000 to 0xE00F.FFFF	0xE000.0000 to 0xE00F.FFFF

(1) First 32KB flash memory (address 0x0000.0000 to 0x0000.8000) has up to 100000 program/erase cycles.

### 8.8.2 Peripheral File Map

Table 8-6 lists the available peripherals and the register base address for each.

**Table 8-6. Peripherals Summary**

PERIPHERAL NAME	BASE ADDRESS	SIZE
COMP0	0x40008000	0x00001F0
VREF	0x40030000	0x00001F0
WWDT0	0x40080000	0x0000150
TIMG14	0x40084000	0x00001F0
TIMG1	0x40086000	0x00001F0
TIMG2	0x40088000	0x00001F0
TIMG8	0x40090000	0x00001F0
LFSS	0x40094000	0x0000160
RTC_B	0x40094000	0x0000160
IWDT	0x40094000	0x0000160
GPIOA	0x400A0000	0x00001F0
GPIOB	0x400A2000	0x00001F0
SYSCTL	0x400AF000	0x0000310
DEBUGSS	0x400C7000	0x00001F0
EVENTLP	0x400C9000	0x0000300
FLASHCTL	0x4042A000	0x00001F0
I2C0	0x40440000	0x0000200
I2C1	0x400CD000	0x0000200
UART1	0x400F0000	0x00001F0
UART2	0x400F2000	0x00001F0
UART0	0x40100000	0x00001F0
CPUSS	0x40102000	0x00001F0
WUC	0x40108000	0x00001F0
IOMUX	0x40400000	0x00001F0
DMA	0x40424000	0x0000050
CRC	0x40428000	0x0000200
SPI0	0x40468000	0x00001F0
ADC0_SVT	0x4055A000	0x0000100

**Table 8-6. Peripherals Summary (continued)**

PERIPHERAL NAME	BASE ADDRESS	SIZE
TIMA0	0x40860000	0x00001F0

### 8.8.3 Peripheral Interrupt Vector

Table 8-7 shows the IRQ number and the interrupt group number for each peripheral in this device.

**Table 8-7. Interrupt Vector Number**

PERIPHERAL NAME	NVIC IRQ
SYSCTL	0
DEBUGSS	1
TIMG8	2
UART1	3
ADC0	4
COMP0	7
UART2	8
SPI0	9
UART0	15
TIMG14	16
TIMG2	17
TIMA0	18
TIMG1	19
GPIOA	22
GPIOB	23
I2C0	24
I2C1	25
FLASHCTL	27
WWDTO	29
LFSS	30
RTC_B	30
IWDT	30
DMA	31

### 8.9 Flash Memory

A single bank of nonvolatile flash memory is provided for storing executable program code and application data.

Key features of the flash include:

- In-circuit program and erase operations supported across the entire recommended supply range
- Small 1KB sector sizes (minimum erase resolution of 1KB)
- Up to 100,000 program/erase cycles on 32 selected sectors of the flash memory, with up to 10,000 program/erase cycles on the remaining flash memory (devices with 32kB support 100,000 cycles on the entire flash memory)

For more details, see the NVM chapter of the [MSPM0 C-Series Microcontrollers Technical Reference Manual](#).

### 8.10 SRAM

MSPM0Cxx MCUs include a low-power high-performance SRAM memory with zero wait state access across the supported CPU frequency range of the device. SRAM memory can be used for storing volatile information such as the call stack, heap, global data, and code. The SRAM memory content is fully retained in RUN, SLEEP, STOP, and STANDBY operating modes and is lost in SHUTDOWN mode. A write protection mechanism is provided to allow the application to dynamically write protect the SRAM memory with 1KB resolution. Write protection is useful when placing executable code into SRAM to provide a level of protection against unintentional overwrites of code by either the CPU or DMA. Placing code in SRAM can improve performance of critical loops by enabling zero wait state operation and lower power consumption.

## 8.11 GPIO

The general purpose input/output (GPIO) peripheral lets the application write data out and read data in through the device pins. Through the use of the Port A and Port B GPIO peripheral, these devices support up to 45 GPIO pins.

The key features of the GPIO module include:

- Set/Clear/Toggle multiple bits without the need of a read-modify-write construct in software
- GPIOs with "Standard with Wake" drive functionality able to wake the device from SHUTDOWN mode
- "FastWake" feature enables low-power wakeup from STOP and STANDBY modes for any GPIO port
- User controlled input filtering

For more details, see the GPIO chapter of the [MSPM0 C-Series Microcontrollers Technical Reference Manual](#).

## 8.12 IOMUX

The IOMUX peripheral enables IO pad configuration and controls digital data flow to and from the device pins. The key features of the IOMUX include:

- IO Pad configuration registers allow for programmable drive strength, speed, pullup-down, and more
- Digital pin muxing allows for multiple peripheral signals to be routed to the same IO pad
- Pin functions and capabilities are user-configured using the PINCM register

For more details, see the IOMUX chapter of the [MSPM0 C-Series Microcontrollers Technical Reference Manual](#).

## 8.13 ADC

The 12-bit analog-to-digital converter (ADC) module in these devices support fast 12-bit conversions with single-ended inputs.

ADC features include:

- 12-bit output resolution at up to 1.6-Msps with 10.6-bit ENOB (external reference)
- Up to 27 external input channels
- Internal channels for temperature sensing, supply monitoring, and analog signal chain
- Software selectable reference:
  - Configurable internal dedicated ADC reference voltage of 1.4V or 2.5V (VREF)
  - MCU supply voltage (VDD)
  - Support for bringing in an external reference on VREF+/- device pins
  - Requires a decoupling capacitor placed on VREF+/- pins for proper operation.
- Operates in RUN, SLEEP, and STOP modes and supports triggers from STANDBY mode

**Table 8-8. ADC0 Channel Mapping**

CHANNEL[0:7]	SIGNAL NAME	CHANNEL[8:15]	SIGNAL NAME
0	A0	16	A16
1	A1	17	A17
2	A2	18	A18
3	A3	19	A19
4	A4	20	A20
5	A5	21	A21
6	A6	22	A22
7	A7	23	A23
8	A8	24	A24
9	A9	25	A25
10	A10	26	A26

**Table 8-8. ADC0 Channel Mapping (continued)**

CHANNEL[0:7]	SIGNAL NAME	CHANNEL[8:15]	SIGNAL NAME
11	A11	27	Reserved
12	A12	28	<i>Temperature Sensor</i>
13	A13	29	VREF
14	A14	30	Reserved
15	A15	31	<i>Supply/Battery Monitor</i>

*Italicized* signal names are internal to the SoC. These signals are used for internal peripheral interconnections.

For more details, see the ADC chapter of the [MSPM0 C-Series Microcontrollers Technical Reference Manual](#).

### 8.14 Temperature Sensor

The temperature sensor provides a voltage output that changes linearly with device temperature. The temperature sensor output is internally connected to one of ADC input channels to enable a temperature-to-digital conversion.

A unit-specific single-point calibration value for the temperature sensor is provided in the factory constants memory region. This calibration value represents the ADC conversion result (in ADC code format) corresponding to the temperature sensor being measured in 12-bit mode with the 1.4V internal VREF at the factory trim temperature ( $TS_{TRIM}$ ). This calibration value can be used with the temperature sensor temperature coefficient ( $TS_C$ ) to estimate the device temperature. See the temperature sensor section of the [MSPM0 C-Series Microcontrollers Technical Reference Manual](#) for guidance on estimating the device temperature with the factory trim value.

### 8.15 Low-Frequency Sub System (LFSS)

The Low-Frequency Sub-System (LFSS) is a sub-system which combines several functional peripherals under one shared subsystem. These peripherals are clocked by the low frequency clock (LFCLK) or need to be active during low power modes. The LFCLK has a typical frequency of 32kHz and is mainly intended for long-term timekeeping.

LFSS in this device contains following components:

- *Real Time Clock* with additional prescaler extension and timestamp captures
- An asynchronous *IWDT*

For more details, see the LFSS chapter of the [MSPM0 C-Series Microcontrollers Technical Reference Manual](#).

### 8.16 VREF

The shared voltage reference module (VREF) in these devices contain a configurable voltage reference buffer which allows users to supply a stable reference to on-board analog peripherals. It also supports bringing in an external reference for applications where higher accuracy is required.

VREF features include:

- 1.4V and 2.5V user-selectable internal references. Same reference voltage will be selected for ADC and COMP
- Internal reference supports ADC operation up to 515ksp/s
- Support for bringing in an external reference on VREF+ and VREF- device pins

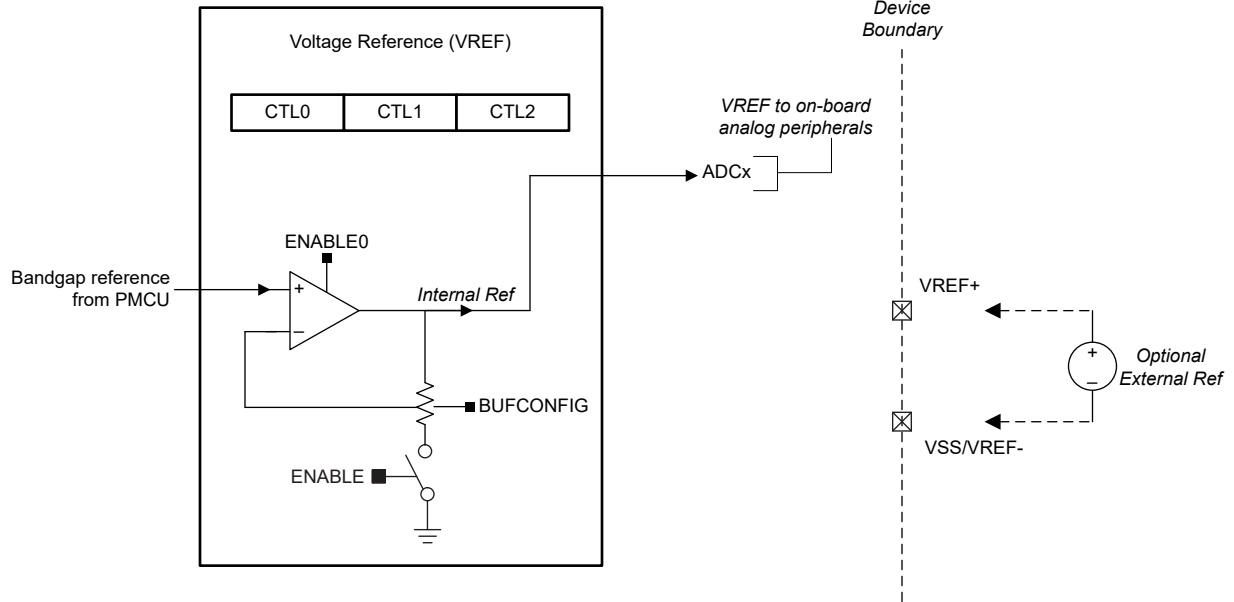

Figure 8-1. VREF module

For more details, see the VREF chapter of the [MSPM0 C-Series Microcontrollers Technical Reference Manual](#).

### 8.17 COMP

The comparator peripheral in the device compares the voltage levels on two inputs terminals and provides a digital output based on this comparison. It supports the following key features:

- Programmable hysteresis
- Programmable reference voltage:
  - External reference voltage (VREF IO)
  - Integrated 8-bit reference DAC
- Configurable operation modes:
  - High speed mode
  - Lower power mode
- Programmable output glitch filter delay
- Supports 6 blanking sources from TIMx instances (see [Table 8-10](#))
- Support output wake up device from all low power modes
- Output connected to advanced timer fault handling mechanism
- The IPSEL and IMSEL bits in comparator registers can be used to select the comparator channel inputs from device pins
- 8-bit reference DAC can be used to output to device pins

Table 8-9. COMP0 Input Channel Selection

IPSEL / IMSEL BITS	POSITIVE TERMINAL INPUT	NEGATIVE TERMINAL INPUT
0x0	COMP0_IN0+	COMP0_IN0-
0x1	COMP0_IN1+	COMP0_IN1-
0x2	COMP0_IN2+	COMP0_IN2-
0x3	COMP0_IN3+	-
0x5	-	Temperature Sensor

Table 8-10. COMP0 Blanking Source Table

CTL2.BLANKSRC	Blanking Source Selected
1	TIMA0.CC2
2	TIMA0.CC3

**Table 8-10. COMP0 Blanking Source Table (continued)**

CTL2.BLANKSRC	Blanking Source Selected
3	TIMA0.CC1
4	TIMG0.CC1
5	TIMG1.CC1
6	TIMG8.CC1

For more information about device analog connections, refer to [Section 8.27](#).

For more details, see the COMP chapter of the [MSPM0 C-Series Microcontrollers Technical Reference Manual](#).

## 8.18 Security

This device offers several security features, including:

- Debug security
- Unique Die ID
- Flexible firewalls for protecting code and data
  - Flash write-erase protection
  - Flash read-execute protection
  - Flash IP protection
  - SRAM write-execute mutual exclusion
- Secure boot
- Secure firmware update
- Customer secure code
- Cyclic redundancy checker (CRC-16) with support for custom polynomial

For more details, see the Security chapter of the [MSPM0 C-Series Microcontrollers Technical Reference Manual](#)

## 8.19 CRC

The cyclical redundancy check (CRC) module provides a signature for an input data sequence. Key features of the CRC module include:

- Support for 16-bit CRC based on CRC16-CCITT
- Support for bit reversal

For more details, see the CRC chapter of the [MSPM0 C-Series Microcontrollers Technical Reference Manual](#).

## 8.20 UART

The UART peripherals (UART0, UART1, UART2) provide the following key features:

- Standard asynchronous communication bits for start, stop, and parity
- Fully programmable serial interface
  - 5, 6, 7 or 8 data bits
  - Even, odd, stick, or no-parity bit generation and detection
  - 1 or 2 stop bit generation
  - Line-break detection
  - Glitch filter on the input signals
  - Programmable baud rate generation with oversampling by 16, 8 or 3
  - Local Interconnect Network (LIN) mode support
- Separated 4-entry transmit and receive FIFOs support DAM data transfer
- Support transmit and receive loopback mode operation
- See [Table 8-11](#) for detail information on supported protocols.

**Table 8-11. UART Features**

UART Features	UART0(Extend)	UART1, UART2(Main)
Active in Stop and Standby Mode	Yes	Yes
Separate transmit and receive FIFOs	Yes	Yes

**Table 8-11. UART Features (continued)**

UART Features	UART0(Extend)	UART1, UART2(Main)
Support hardware flow control	Yes	Yes
Support 9-bit configuration	Yes	Yes
Support LIN mode	Yes	-
Support DALI	Yes	-
Support IrDA	Yes	-
Support ISO7816 Smart Card	Yes	-
Support Manchester coding	Yes	-

For more details, see the UART chapter of the [MSPM0 C-Series Microcontrollers Technical Reference Manual](#).

### 8.21 I2C

The inter-integrated circuit interface (I<sup>2</sup>C) peripherals in these devices provide bidirectional data transfer with other I2C devices on the bus and support the following key features:

- 7-bit and 10-bit addressing mode with multiple 7-bit target addresses
- Multiple-controller transmitter or receiver mode
- Target receiver or transmitter mode with configurable clock stretching
- Support Standard-mode (Sm), with a bit rate up to 100kbps
- Support Fast-mode (Fm), with a bit rate up to 400kbps
- Support Fast-mode Plus (Fm+), with a bit rate up to 1Mbps
- Separated 4-entry transmit and receive FIFOs support DMA data transfer
- Support SMBus 3.0 with PEC, ARP, timeout detection and host support
- Wakeup from low power mode on address match
- Support analog and digital glitch filter for input signal glitch suppression

For more details, see the I2C chapter of the [MSPM0 C-Series Microcontrollers Technical Reference Manual](#).

### 8.22 SPI

The serial peripheral interface (SPI) peripherals in these devices support the following key features:

- Support ULPCLK/2 bit rate and up to 16Mbits/s in both controller and peripheral mode
- Configurable as a controller or a peripheral
- Configurable chip select for both controller and peripheral
- Programmable clock prescaler and bit rate
- Programmable data frame size from 4 bits to 16 bits (controller mode)
- Programmable data frame size from 7 bits to 16 bits (peripheral mode)
- Separated 4-entry transmit and receive FIFOs support DMA data transfer
- Supports TI mode, Motorola mode, and National Microwire format

For more details, see the SPI chapter of the [MSPM0 C-Series Microcontrollers Technical Reference Manual](#).

### 8.23 IWDT

The independent watchdog timer (IWDT) in the LFSS is a device-independent supervisor which monitors code execution and overall hang up scenarios of the device. Due to the nature of LFSS, this IWDT has its own system independent power and clock source. If the application software does not successfully reset the watchdog within the programmed time, the watchdog generates a POR reset to the device.

Key features of the IWDT include:

- A 25-bit counter with closed and open window
- Counter driven from LFOSC (fixed 32kHz clock path) with a programmable clock divider
- Eight selectable watchdog timer periods

For more details, see the IWDT chapter of the [MSPM0 C-Series Microcontrollers Technical Reference Manual](#).

## 8.24 WWDT

The windowed watchdog timer (WWDT) can be used to supervise the operation of the device, specifically code execution. The WWDT can be used to generate a reset or an interrupt if the application software does not successfully reset the watchdog within a specified window of time. Key features of the WWDT include:

- 25-bit counter
- Programmable clock divider
- Eight software selectable watchdog timer periods
- Eight software selectable window sizes
- Support for stopping the WWDT automatically when entering a sleep mode
- Interval timer mode for applications which do not require watchdog functionality

For more details, see the WWDT chapter of the [MSPM0 C-Series Microcontrollers Technical Reference Manual](#).

## 8.25 RTC\_B

The RTC\_B instance of the real-time clock operates off of a 32kHz input clock source (typically a low frequency crystal) and provides a time base to the application with multiple options for interrupts to the CPU. The RTC\_B provides common key features in relation to the Low-Frequency Sub System (LFSS).

Common key features of the RTC\_B include:

- Counters for seconds, minutes, hours, day of the week, day of the month, month, and year
- Binary or BCD format
- Leap-year handling
- One customizable alarm interrupt based on minute, hour, day of the week, and day of the month
- Interval alarm interrupt to wake every minute, every hour, at midnight, or at noon
- Interval alarm interrupt providing periodic wake-up at 4096, 2048, 1024, 512, 256, or 128 Hz
- Interval alarm interrupt providing periodic wake-up at 64, 32, 16, 8, 4, 2, 1, and 0.5 Hz
- Calibration for crystal offset error (up to +/- 240ppm)
- Compensation for temperature drift (up to +/- 240ppm)
- RTC clock output to pin for calibration

Table 8-12 shows the RTC features supported in this device.

**Table 8-12. RTC\_B Key Features**

RTC Features	RTC_B
Power enable register	-
Real-time clock and calendar mode providing seconds, minutes, hours, day of week, day of month, and year	Yes
Selectable binary or binary-coded decimal (BCD) format	Yes
Leap-year correction (valid for year 1901 through 2099)	Yes
Two customizable calendar alarm interrupts based on minute, hour, day of the week, and day of the month	Yes
Interval alarm interrupt to wake every minute, every hour, at midnight, or at noon	Yes
Periodic interrupt to wake at 4096, 2048, 1024, 512, 256, or 128Hz	Yes
Periodic interrupt to wake at 64, 32, 16, 8, 4, 2, 1, and 0.5Hz	Yes
Interrupt capability down to STANDBY mode with STOPCLKSTBY	Yes
Calibration for crystal offset error and crystal temperature drift (up to ±240 ppm total)	Yes
RTC clock output to pin for calibration (GPIO)	Yes
RTC clock output to pin for calibration (TIO)	-

**Table 8-12. RTC\_B Key Features (continued)**

RTC Features	RTC_B
Three -bit prescaler for heartbeat function with interrupt generation	-
RTC external clock selection of untrimmed 32kHz, trimmed 512Hz, 256Hz or 1Hz	-
RTC time stamp capture upon detection of a timer stamp event, including: <ul style="list-style-type: none"> <li>• TIO event</li> <li>• VDD fail event</li> </ul>	-
RTC counter lock function	-

For more details, see the RTC chapter of the [MSPM0 C-Series Microcontrollers Technical Reference Manual](#).

## 8.26 Timers (TIMx)

The timer peripherals in these devices support the following key features. For specific configuration, see [Table 8-13](#).

Specific features for the **general-purpose timer (TIMGx)** include:

- 16-bit down, up/down, or up counter with repeat-reload mode
- Selectable and configurable clock source
- 8-bit programmable prescaler to divide the counter clock frequency
- Up to four independent CC channels for
  - Output compare
  - Input capture
  - PWM output
  - One-shot mode
- Support quadrature encoder interface (QEI) for positioning and movement sensing
- Support synchronization and cross trigger among different TIMx instances in the same power domain
- Support interrupt trigger generation and cross peripherals (such as ADC) trigger capability
- Cross-trigger event logic for Hall sensor inputs

Specific features for the **advanced timer (TIMAx)** include:

- 16-bit down or up-down counter, with repeat-reload mode
- Selectable and configurable clock source
- 8-bit programmable prescaler to divide the counter clock frequency
- Clock doubler to provide 2x clock source for improved timer resolution
- Repeat counter to generate an interrupt or event only after a given number of cycles of the counter
- Up to four independent CC channels for
  - Output compare
  - Input capture
  - PWM output
  - One-shot mode
- Shadow register for load and CC register available
- Complementary output PWM
- Asymmetric PWM with programmable dead band insertion
- Fault handling mechanism to keep the output signals in a safe user-defined state when a fault condition is encountered
- Support synchronization and cross trigger among different TIMx instances in the same power domain
- Support interrupt trigger generation and cross peripherals (such as ADC) trigger capability
- Two additional capture/compare channels for internal events

**Table 8-13. TIMx Configurations**

TIMER NAME	POWER DOMAIN	RESOLUTION	PRESCALER	REPEAT COUNTER	CAPTURE / COMPARE CHANNELS	PHASE LOAD	SHADOW LOAD	SHADOW CC	DEAD-BAND	FAULT	QEI
TIMG14	PD0	16 bit	8 bit	–	4	–	–	–	–	–	–
TIMG1	PD0	16 bit	8 bit	–	2	–	–	–	–	–	–
TIMG2	PD0	16 bit	8 bit	–	2	–	–	–	–	–	–
TIMG8	PD0	16 bit	8 bit	–	2	–	–	–	–	–	Yes
TIMA0	PD0	16 bit	8 bit	8-bit	4	Yes	Yes	Yes	Yes	Yes	–

For more details, see the TIMx chapter of the [MSPM0 C-Series Microcontrollers Technical Reference Manual](#).

## 8.27 Device Analog Connections

Figure 8-2 shows the internal analog connection of the device.

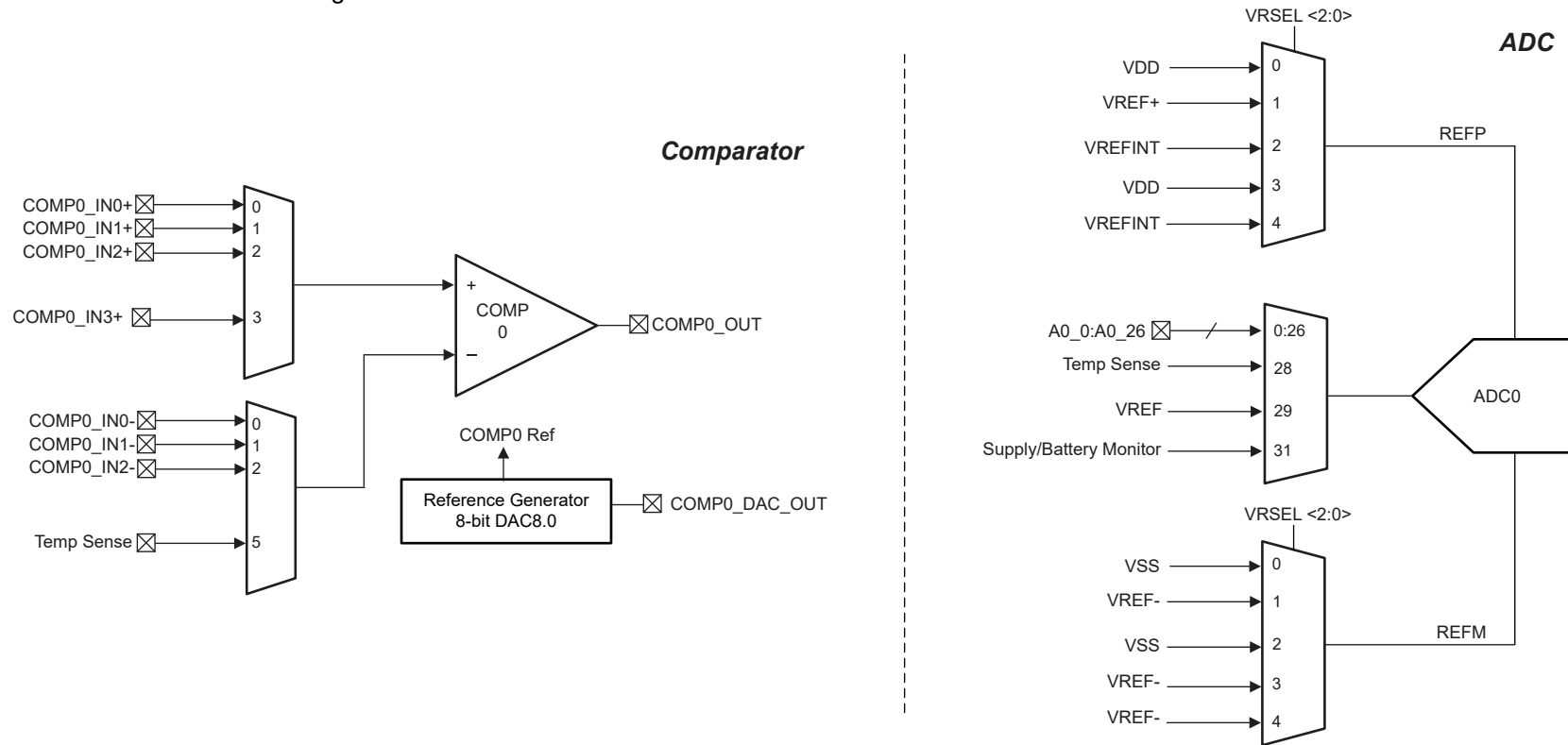
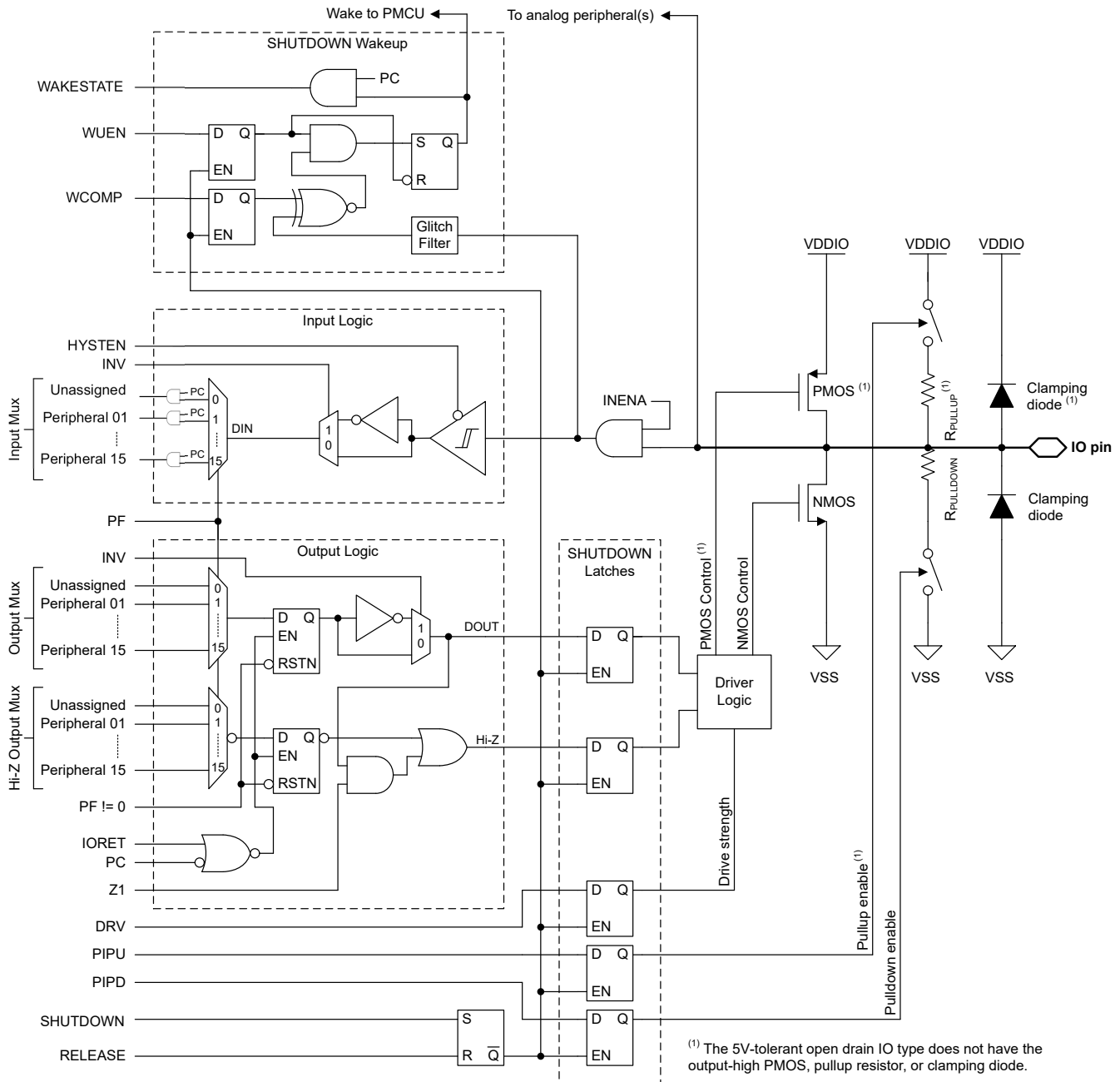

**Figure 8-2. Device Analog Connection**

## 8.28 Input/Output Diagrams

The IOMUX manages the selection of which peripheral function is to be used on a digital IO. It also provides the controls for the output driver, input path, and the wake-up logic for wakeup from SHUTDOWN mode. For more information, refer to the IOMUX section of the [MSPM0 C-Series Microcontrollers Technical Reference Manual](#).

The mixed-signal IO pin slice diagram for a full featured IO pin is shown in [Figure 8-3](#). Not all pins will have analog functions, wake-up logic, drive strength control, and pullup or pulldown resistors available.



**Figure 8-3. Superset Input/Output Diagram**

## 8.29 Serial Wire Debug Interface

A serial wire debug (SWD) two-wire interface is provided via an Arm compatible serial wire debug port (SW-DP) to enable access to multiple debug functions within the device.

**Table 8-14. Serial Wire Debug Pin Requirements and Functions**

DEVICE SIGNAL	DIRECTION	SWD FUNCTION
SWCLK	Input	Serial wire clock from debug probe
SWDIO	Input/Output	Bi-directional (shared) serial wire data

For a complete description of the debug functionality offered on MSPM0 devices, see the Debug chapter of the [MSPM0 C-Series Microcontrollers Technical Reference Manual](#).

### 8.30 DEBUGSS

The debug subsystem (DEBUGSS) interfaces the ARM Serial Wire Debug (SWD) two-wire physical interface to multiple debug functions within the device. MSPM0 devices support debugging of processor execution and the device state. The DEBUGSS also provides a mailbox system for communicating with software through SWD.

Key features provided by the debug subsystem include:

- The ARM Serial Wire Debug (SWD) two-wire (SWDIO, SWCLK) debug interface, compatible with both TI and 3<sup>rd</sup> party debug probes
  - On-chip pullup and pulldown resistors for SWDIO and SWCLK, respectively, enabled by default
  - Support for disabling SWD functions to use SWD pins as general-purpose input/output pins
  - Support for debug on all low power modes
- Debug of the processor
  - Run, halt, and step debug support
  - 2 hardware breakpoints (BPU)
  - 1 hardware watchpoints (DWT)
  - Supporting software breakpoints
- Software-configurable peripheral behavior during processor debug
  - Ability to free run select peripherals through debug halt
  - Ability to halt select peripherals on a debug halt
  - Ability to request reset and mode changes to the PMCU
- Mailbox (DSSM) for passing data and control signals between the SWD interface and boot ROM (as well as application software)
- Support for various security features, including SWD lockout and password authenticated debugging

For more details, see the DEBUGSS chapter of the [MSPM0 C-Series Microcontrollers Technical Reference Manual](#).

### 8.31 Device Factory Constants

All devices include a memory-mapped FACTORY region which provides read-only data describing the capabilities of a device as well as any factory-provided trim information for use by application software. Please refer to Factory Constants chapter of the [MSPM0 C-Series Microcontrollers Technical Reference Manual](#) for more information.

**Table 8-15. DEVICEID**

DEVICEID address is 0x41C4.0004, PARTNUM is bit 12 to 27, MANUFACTURER is bit 1 to 11.

Device	PARTNUM	MANUFACTURER
MSPM0C1105	0xBBBA	0x17
MSPM0C1106	0xBBBA	0x17

**Table 8-16. USERID**

USERID address is 0x41C4.0008, PART is bit 0 to 15, VARIANT is bit 16 to 23

Device	Part	Variant
MSPM0C1105SPTR	CC25	31
MSP32C031C6SPTR	CC25	53
MSP32G031C6SPTR	CC25	54
MSPM0C1105SDGS28R	CC25	33

**Table 8-16. USERID (continued)**

USERID address is 0x41C4.0008, PART is bit 0 to 15, VARIANT is bit 16 to 23

Device	Part	Variant
MSPM0C1105SDGS20R	CC25	34
MSPM0C1105SRGZR	CC25	35
MSPM0C1105SRHBR	CC25	36
MSPM0C1105SRGER	CC25	37
MSPM0C1105SRUKR	CC25	38
MSP32G031C6SVFCR	CC25	39
MSP32C031C6SVFCR	CC25	55
MSPM0C1105SZCMR	CC25	60
MSPM0C1106SPTR	F5CF	3A
MSP32G031C8SPTR	F5CF	56
MSPM0C1106SDGS28R	F5CF	3C
MSPM0C1106SDGS20R	F5CF	3D
MSPM0C1106SRGZR	F5CF	3E
MSPM0C1106SRHBR	F5CF	3F
MSPM0C1106SRGER	F5CF	40
MSPM0C1106SRUKR	F5CF	41
MSP32G031C8SVFCR	F5CF	42
MSPM0C1106SZCMR	F5CF	61

## 8.32 Identification

### Revision and Device Identification

The hardware revision and device identification values are stored in the memory-mapped FACTORY region, refer to Device Factory Constants section, which provides read-only data describing the capabilities of a device as well as any factory-provided trim information for use by application software. Refer to the Factory Constants chapter of the *MSPM0 C-Series Microcontrollers Technical Reference Manual* for more information.

The device revision and identification information are also included as part of the top-side marking on the device package. The device-specific errata sheet describes these markings (see [Section 10.4](#)).

## 9 Applications, Implementation, and Layout

### 9.1 Typical Application

#### Note

Information in the following applications sections is not part of the TI component specification, and TI does not warrant its accuracy or completeness. TI's customers are responsible for determining suitability of components for their purposes, as well as validating and testing their design implementation to confirm system functionality.

#### 9.1.1 Schematic

TI recommends connecting a combination of a 10 $\mu$ F and a 0.1 $\mu$ F low-ESR ceramic decoupling capacitor to the VDD and VSS pins. Higher-value capacitors may be used but can impact supply rail ramp-up time. Decoupling capacitors must be placed as close as possible to the pins that they decouple (within a few millimeters).

The NRST reset pin is required to connect an external 47k $\Omega$  pullup resistor with a 1000pF pulldown capacitor.

For devices supporting external crystals, external bypass capacitors for the crystal oscillator pins are required. Refer to *MSPM0 C-Series Microcontrollers Technical Reference Manual* which explains how to calculate the capacitor value.

For 5V-tolerant open drain IOs (ODIO), a pullup resistor is required to output a logic high signal. This is required for I<sup>2</sup>C and UART functions if the ODIO are used.

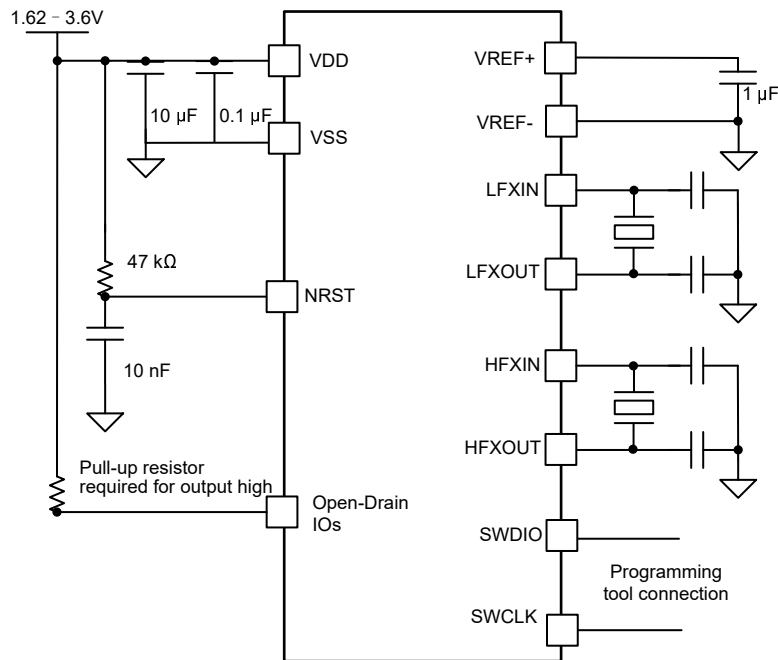

**Figure 9-1. Typical Application Schematic**

## 10 Device and Documentation Support

TI offers an extensive line of development tools. Tools and software to evaluate the performance of the device, generate code, and develop solutions are listed below.

### 10.1 Getting Started and Next Steps

For more information on the MSP low-power microcontrollers and the tools and libraries that are available to help with development, visit the Texas Instruments [Arm Cortex-M0+ MCUs](#) page.

### 10.2 Device Nomenclature

To designate the stages in the product development cycle, TI assigns prefixes to the part numbers of all MSP MCU devices and support tools. Each MSP MCU commercial family member has one of two prefixes: MSP or X. These prefixes represent evolutionary stages of product development from engineering prototypes (X) through fully qualified production devices (MSP).

**X** – Experimental device that is not necessarily representative of the final device's electrical specifications

**MSP** – Fully qualified production device

**X** devices are shipped against the following disclaimer:

"Developmental product is intended for internal evaluation purposes." MSP devices have been characterized fully, and the quality and reliability of the device have been demonstrated fully. TI's standard warranty applies. Predictions show that prototype devices (X) have a greater failure rate than the standard production devices. TI recommends that these devices not be used in any production system because their expected end-use failure rate still is undefined. Only qualified production devices are to be used.

TI device nomenclature also includes a suffix with the device family name. This suffix indicates the temperature range, package type, and distribution format. [Figure 10-1](#) provides a legend for reading the complete device name.

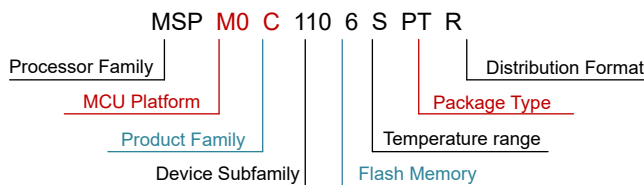

**Figure 10-1. Device Nomenclature**

**Table 10-1. Device Nomenclature**

<b>Processor Family</b>	MSP = Mixed-signal processor X= Experimental silicon
<b>MCU Platform</b>	M0 = Arm based 32-bit M0+
<b>Product Family</b>	C = 32MHz frequency
<b>Device Subfamily</b>	1105/6 = 32MHz frequency, ADC, RTC, CMP
<b>Flash Memory</b>	5 = 32KB 6= 64KB
<b>Temperature Range</b>	S = –40°C to 125°C
<b>Package Type</b>	See the <i>Device Comparison</i> section and <a href="https://www.ti.com/packaging">https://www.ti.com/packaging</a>
<b>Distribution Format</b>	R = Large reel No marking = Tube or tray

For orderable part numbers of MSP devices in different package types, see the Package Option Addendum of this document, [ti.com](https://www.ti.com), or contact your TI sales representative.

## 10.3 Tools and Software

### Design Kits and Evaluation Modules

[MSPM0 LaunchPad \(LP\)](#)  
[Boards: LP-MSPM0C1106](#)

Empowers you to immediately start developing on the industry's best integrated analog and most cost-optimized general purpose MSPM0 MCU family. Exposes all device pins and functionality; includes some built-in circuitry, out-of-box software demos, and on-board XDS110 debug probe for programming/debugging/EnergyTrace.

The LP ecosystem includes dozens of [BoosterPack](#) stackable plug-in modules to extend functionality.

### Embedded Software

[MSPM0 Software Development Kit \(SDK\)](#)

Contains software drivers, middleware libraries, documentation, tools, and code examples that create a familiar and easy user experience for all MSPM0 devices.

### Software Development Tools

[TI Cloud Tools](#)

Start your evaluation and development on a web browser without any installation. Cloud tools also have a downloadable, offline version.

[TI Resource Explorer](#)

Online portal to TI SDKs. Accessible in CCS IDE or in TI Cloud Tools.

[SysConfig](#)

Intuitive GUI to configure device and peripherals, resolve system conflicts, generate configuration code, and automate pin mux settings. Accessible in CCS IDE or in TI Cloud Tools. ([offline version](#))

[MSP Academy](#)

Great starting point for all developers to learn about the MSPM0 MCU Platform with training modules that span a wide range of topics. Part of TIRex.

[GUI Composer](#)

GUIs that simplify evaluation of certain MSPM0 features, such as configuring and monitoring a fully integrated analog signal chain without any code needed.

### IDE & compiler toolchains

[Code Composer Studio™ \(CCS\)](#)

Includes [TI Arm-Clang](#) compiler. Supports all TI Arm Cortex MCUs and boasts competitive code size performance advantages, fast compile time, code coverage support, safety certification support, and completely free to use.

[IAR Embedded Workbench® IDE](#)

[Keil® MDK IDE](#)

[GNU Arm Embedded Toolchain](#)

## 10.4 Documentation Support

To receive notification of documentation updates, navigate to the device product folder on [ti.com](#). Click on *Subscribe to updates* to register and receive a weekly digest of any product information that has changed. For change details, review the revision history included in any revised document.

The following documents describe the MSPM0 MCUs. Copies of these documents are available on the Internet at [www.ti.com](#).

### Technical Reference Manual

[MSPM0 C-Series Microcontrollers Technical Reference Manual](#)

This manual describes the modules and peripherals of the family of devices. Each description presents the module or peripheral in a general sense. Not all features and functions of all modules or peripherals are present on all devices. In addition, modules or peripherals can differ in their exact implementation on different devices.

Pin functions, internal signal connections, and operational parameters differ from device to device. See the device-specific data sheet for these details.

## 10.5 Support Resources

[TI E2E™ support forums](#) are an engineer's go-to source for fast, verified answers and design help — straight from the experts. Search existing answers or ask your own question to get the quick design help you need.

Linked content is provided "AS IS" by the respective contributors. They do not constitute TI specifications and do not necessarily reflect TI's views; see TI's [Terms of Use](#).

## 10.6 Trademarks

LaunchPad™, Code Composer Studio™, and TI E2E™ are trademarks of Texas Instruments.

Arm® and Cortex® are registered trademarks of Arm Limited.

All trademarks are the property of their respective owners.

## 10.7 Electrostatic Discharge Caution



This integrated circuit can be damaged by ESD. Texas Instruments recommends that all integrated circuits be handled with appropriate precautions. Failure to observe proper handling and installation procedures can cause damage.

ESD damage can range from subtle performance degradation to complete device failure. Precision integrated circuits may be more susceptible to damage because very small parametric changes could cause the device not to meet its published specifications.

## 10.8 Glossary

[TI Glossary](#) This glossary lists and explains terms, acronyms, and definitions.

## 11 Revision History

NOTE: Page numbers for previous revisions may differ from page numbers in the current version.

### Changes from September 30, 2025 to January 30, 2026 (from Revision A (September 2025) to Revision B (January 2026))

	<b>Page</b>
• Removed the ZCM table footnotes.....	2
• Updated thermal information with ZCM.....	41
• Added VREF module block diagram.....	68
• Clarified the FIFO entries description.....	70
• Clarified the FIFO entries description.....	71
• Clarified the FIFO entries description.....	71

## 12 Mechanical, Packaging, and Orderable Information

The following pages include mechanical, packaging, and orderable information. This information is the most current data available for the designated devices. This data is subject to change without notice and revision of this document. For browser-based versions of this data sheet, refer to the left-hand navigation.

**RGZ0048B**

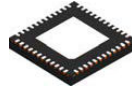

**PACKAGE OUTLINE**  
**VQFN - 1 mm max height**

PLASTIC QUAD FLATPACK - NO LEAD

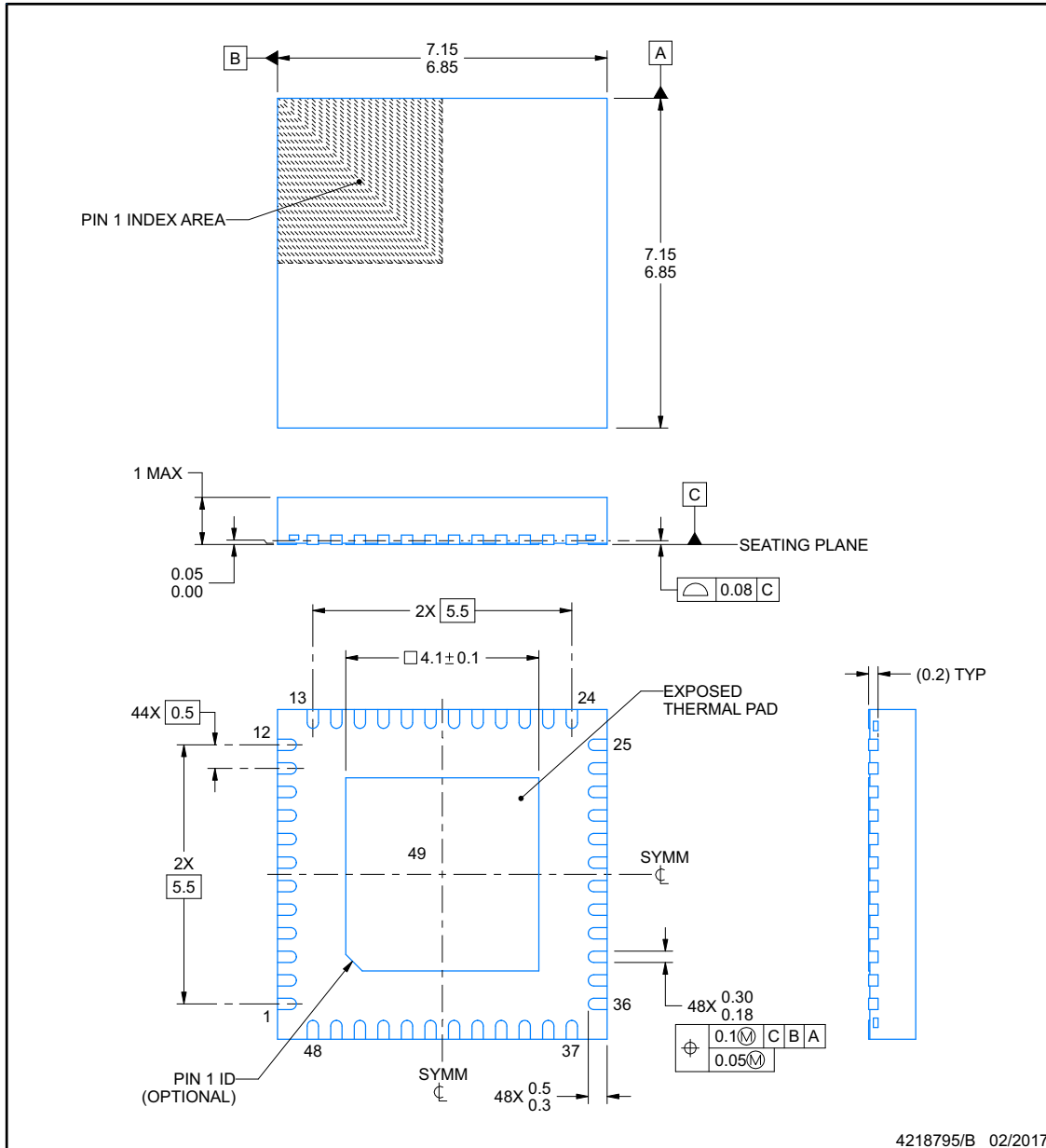

4218795/B 02/2017

**NOTES:**

1. All linear dimensions are in millimeters. Any dimensions in parenthesis are for reference only. Dimensioning and tolerancing per ASME Y14.5M.
2. This drawing is subject to change without notice.
3. The package thermal pad must be soldered to the printed circuit board for thermal and mechanical performance.

## EXAMPLE BOARD LAYOUT

**RGZ0048B**

**VQFN - 1 mm max height**

PLASTIC QUAD FLATPACK - NO LEAD

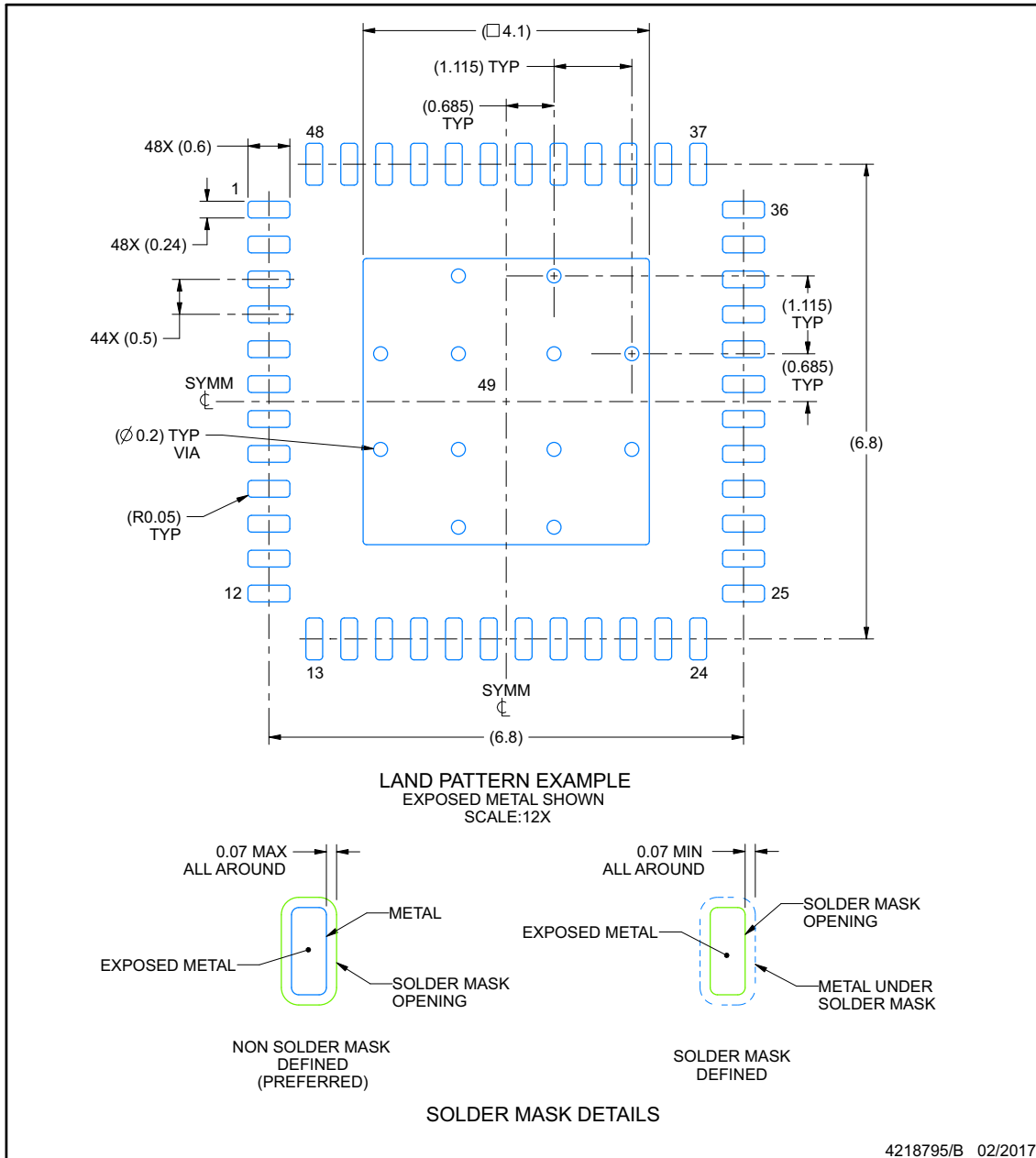

NOTES: (continued)

4. This package is designed to be soldered to a thermal pad on the board. For more information, see Texas Instruments literature number SLUA271 ([www.ti.com/lit/slua271](http://www.ti.com/lit/slua271)).
5. Vias are optional depending on application, refer to device data sheet. If any vias are implemented, refer to their locations shown on this view. It is recommended that vias under paste be filled, plugged or tented.

## EXAMPLE STENCIL DESIGN

**RGZ0048B**

**VQFN - 1 mm max height**

PLASTIC QUAD FLATPACK - NO LEAD

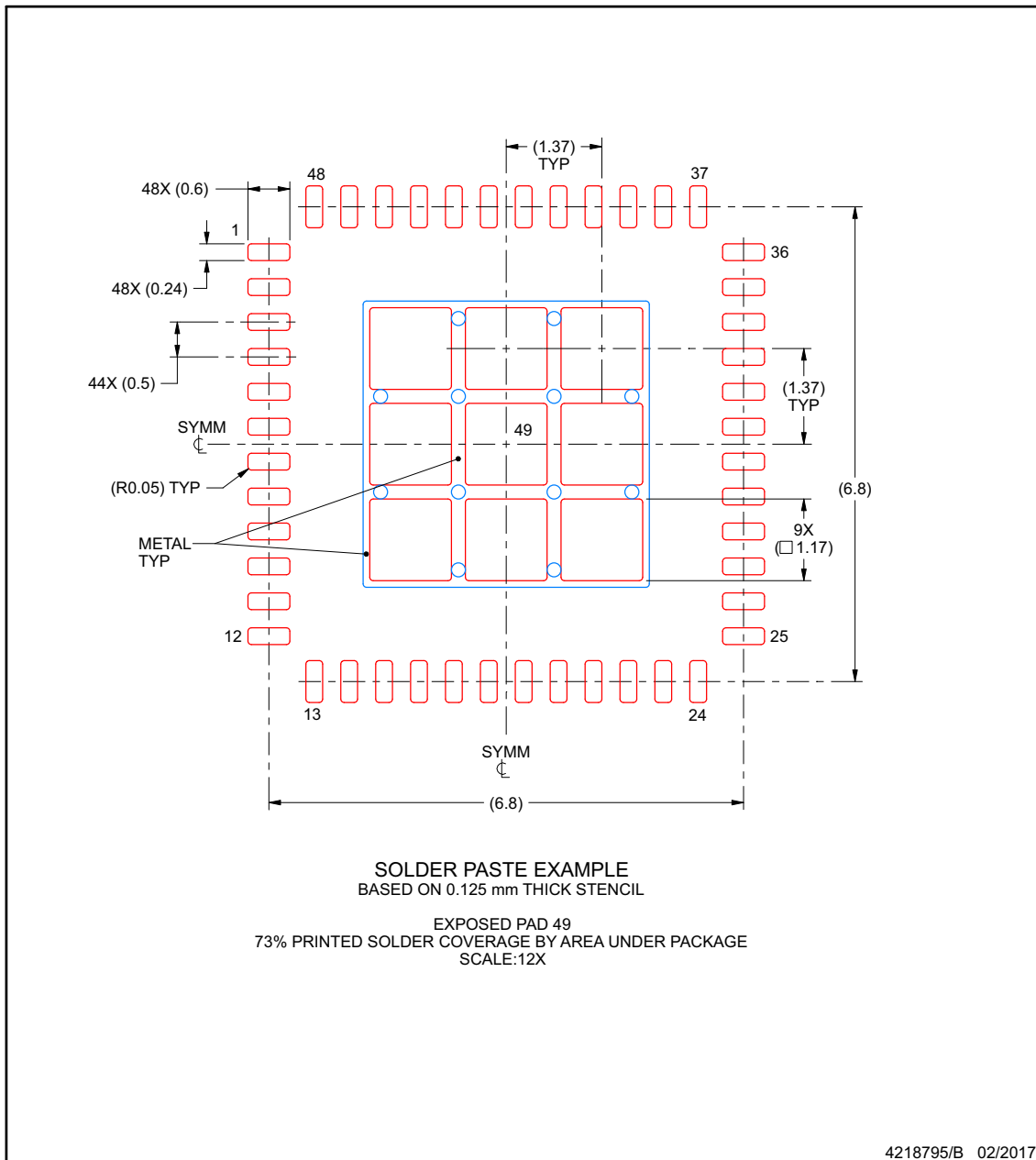

NOTES: (continued)

6. Laser cutting apertures with trapezoidal walls and rounded corners may offer better paste release. IPC-7525 may have alternate design recommendations.

## GENERIC PACKAGE VIEW

**RHB 32**

5 x 5, 0.5 mm pitch

**VQFN - 1 mm max height**

PLASTIC QUAD FLATPACK - NO LEAD

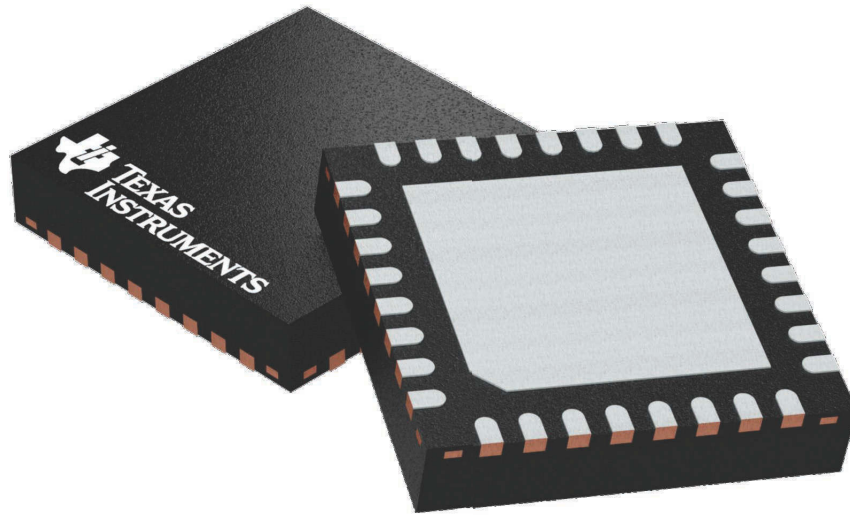

Images above are just a representation of the package family, actual package may vary.  
Refer to the product data sheet for package details.

4224745/A

# RHB0032E

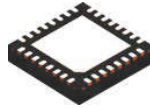

## PACKAGE OUTLINE

### VQFN - 1 mm max height

PLASTIC QUAD FLATPACK - NO LEAD

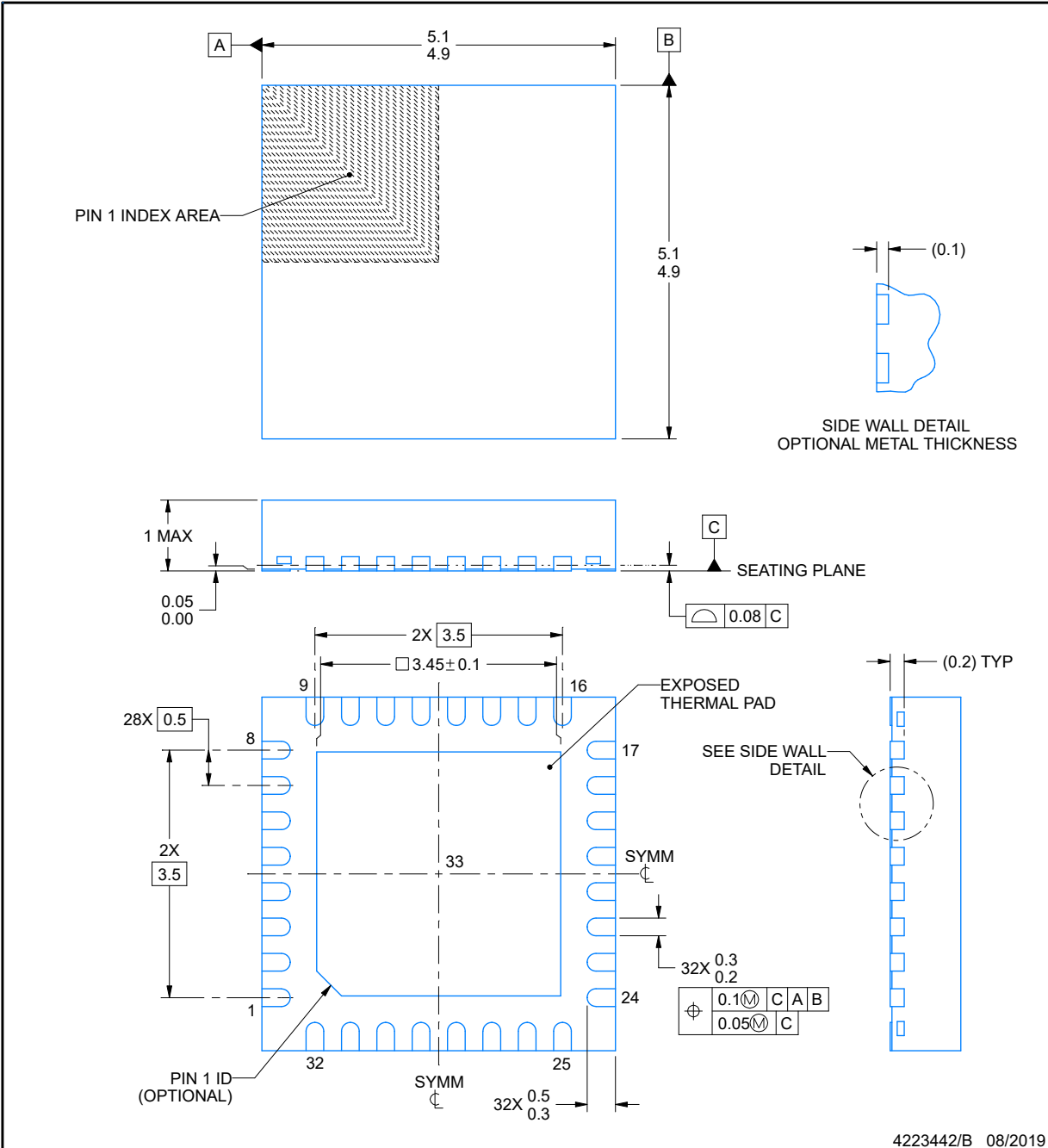

**NOTES:**

1. All linear dimensions are in millimeters. Any dimensions in parenthesis are for reference only. Dimensioning and tolerancing per ASME Y14.5M.
2. This drawing is subject to change without notice.
3. The package thermal pad must be soldered to the printed circuit board for thermal and mechanical performance.

## EXAMPLE BOARD LAYOUT

**RHB0032E**

**VQFN - 1 mm max height**

PLASTIC QUAD FLATPACK - NO LEAD

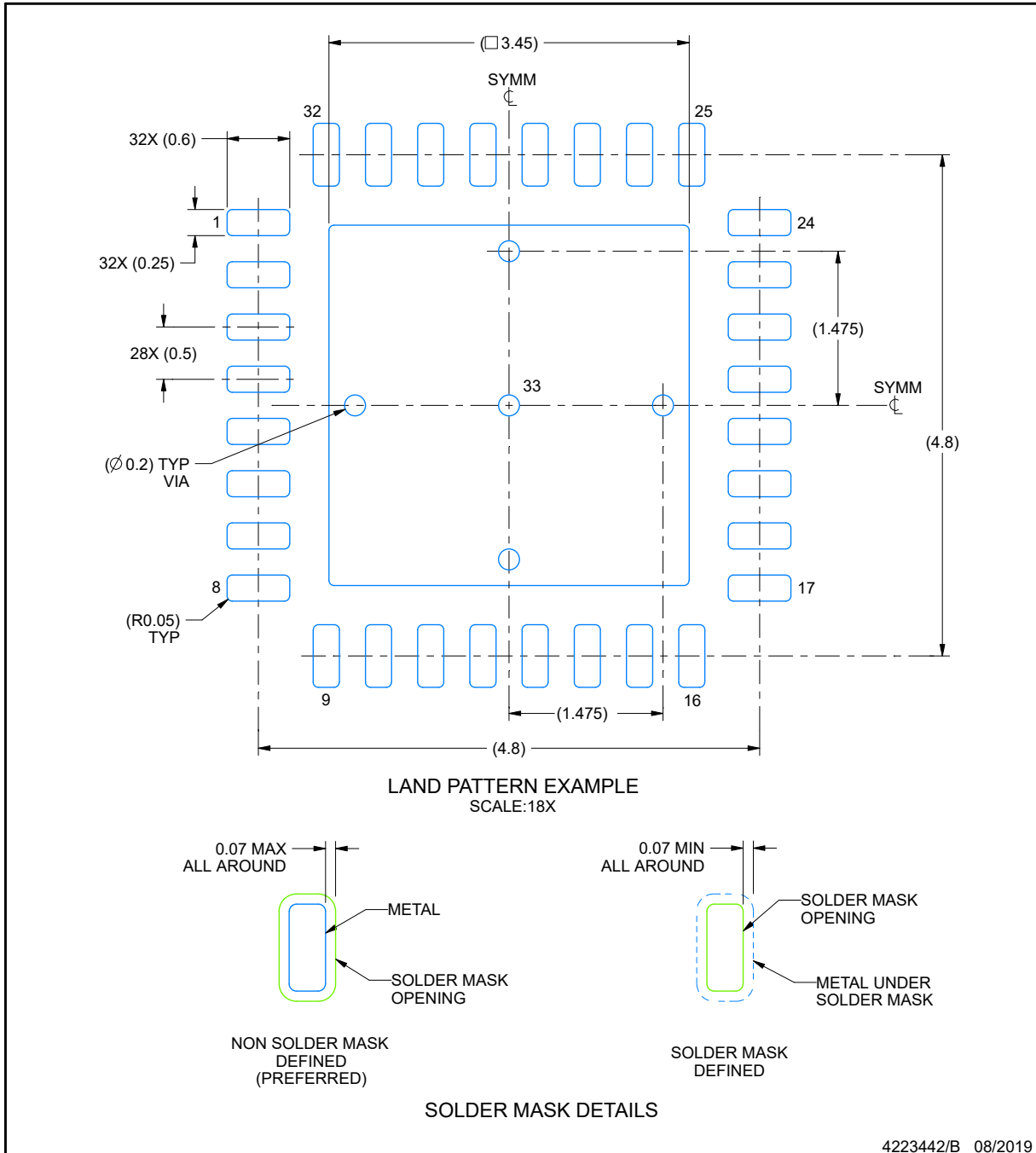

NOTES: (continued)

4. This package is designed to be soldered to a thermal pad on the board. For more information, see Texas Instruments literature number SLUA271 ([www.ti.com/lit/slua271](http://www.ti.com/lit/slua271)).
5. Vias are optional depending on application, refer to device data sheet. If any vias are implemented, refer to their locations shown on this view. It is recommended that vias under paste be filled, plugged or tented.

## EXAMPLE STENCIL DESIGN

**RHB0032E**

**VQFN - 1 mm max height**

PLASTIC QUAD FLATPACK - NO LEAD

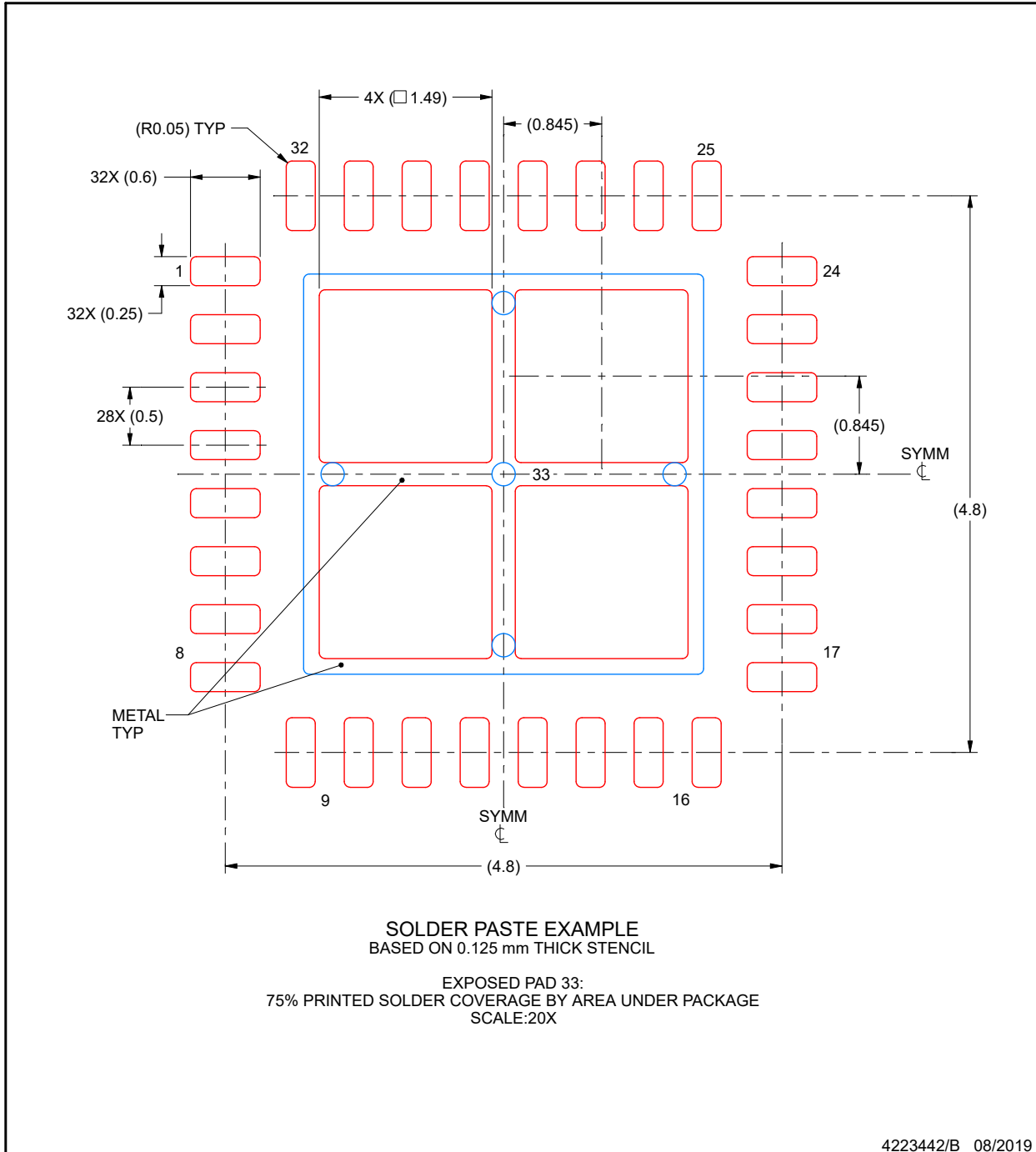

NOTES: (continued)

6. Laser cutting apertures with trapezoidal walls and rounded corners may offer better paste release. IPC-7525 may have alternate design recommendations.

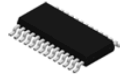

# PACKAGE OUTLINE

**DGS0028A**

**VSSOP - 1.1 mm max height**

SMALL OUTLINE PACKAGE

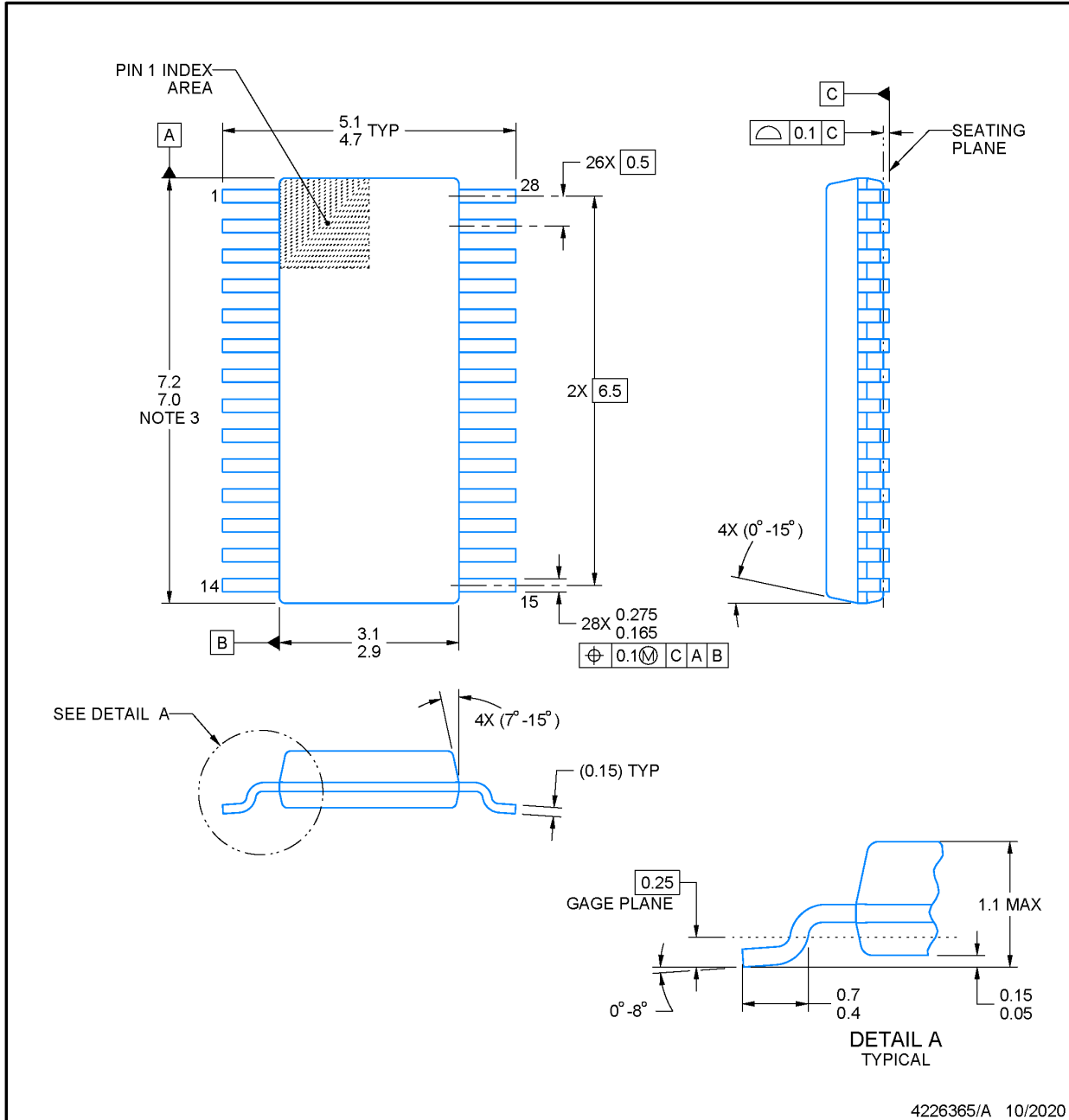

4226365/A 10/2020

**NOTES:**

PowerPAD is a trademark of Texas Instruments.

1. All linear dimensions are in millimeters. Any dimensions in parenthesis are for reference only. Dimensioning and tolerancing per ASME Y14.5M.
2. This drawing is subject to change without notice.
3. This dimension does not include mold flash, protrusions, or gate burrs. Mold flash, protrusions, or gate burrs shall not exceed 0.15 mm per side.
4. No JEDEC registration as of September 2020.
5. Features may differ or may not be present.

## EXAMPLE BOARD LAYOUT

### DGS0028A

### VSSOP - 1.1 mm max height

SMALL OUTLINE PACKAGE

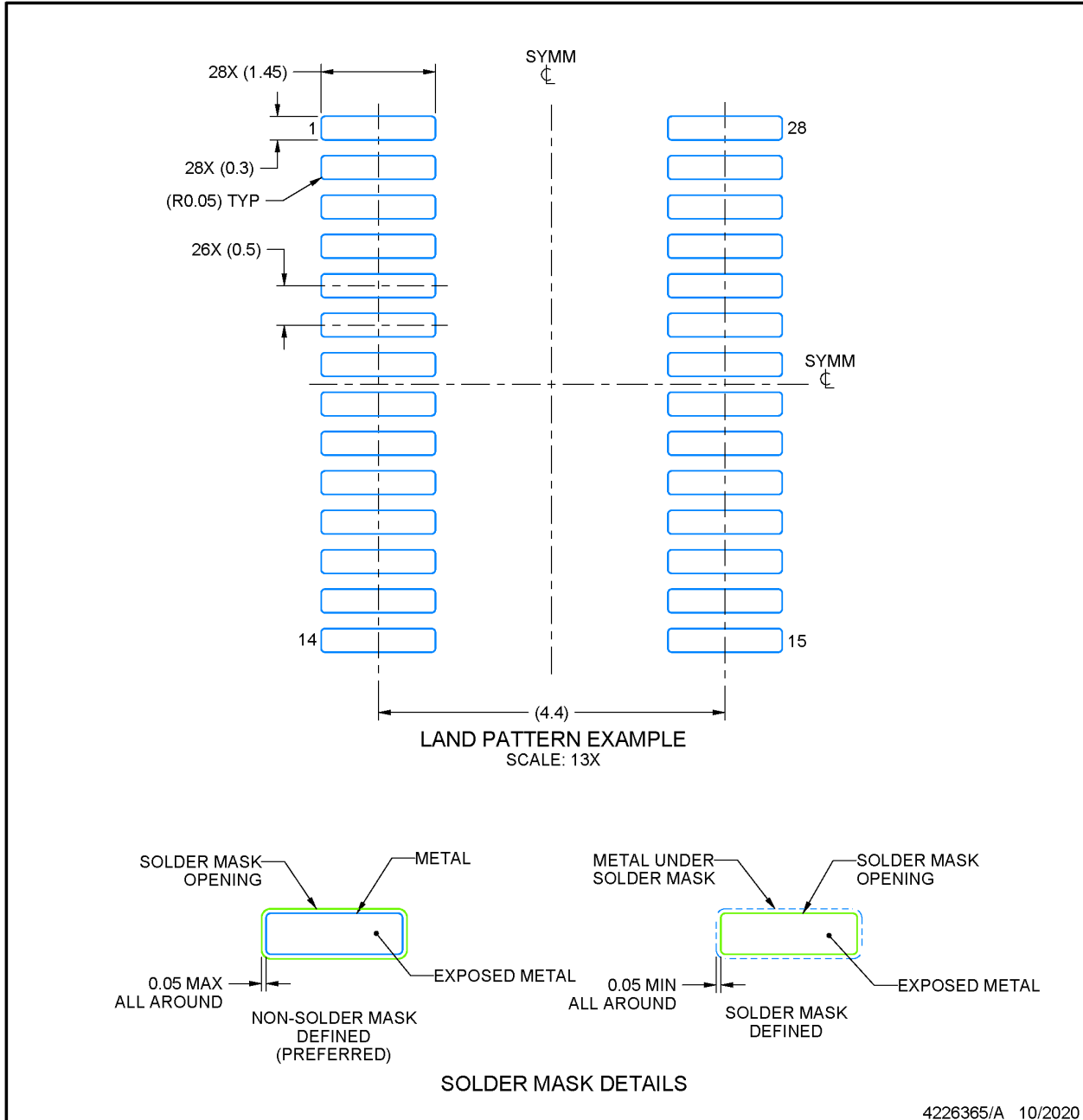

NOTES: (continued)

6. Publication IPC-7351 may have alternate designs.
7. Solder mask tolerances between and around signal pads can vary based on board fabrication site.
8. This package is designed to be soldered to a thermal pad on the board. For more information, see Texas Instruments literature numbers SLMA002 ([www.ti.com/lit/slma002](http://www.ti.com/lit/slma002)) and SLMA004 ([www.ti.com/lit/slma004](http://www.ti.com/lit/slma004)).
9. Size of metal pad may vary due to creepage requirement.
10. Vias are optional depending on application, refer to device data sheet. It is recommended that vias under paste be filled, plugged or tented.

## EXAMPLE STENCIL DESIGN

**DGS0028A**

**VSSOP - 1.1 mm max height**

SMALL OUTLINE PACKAGE

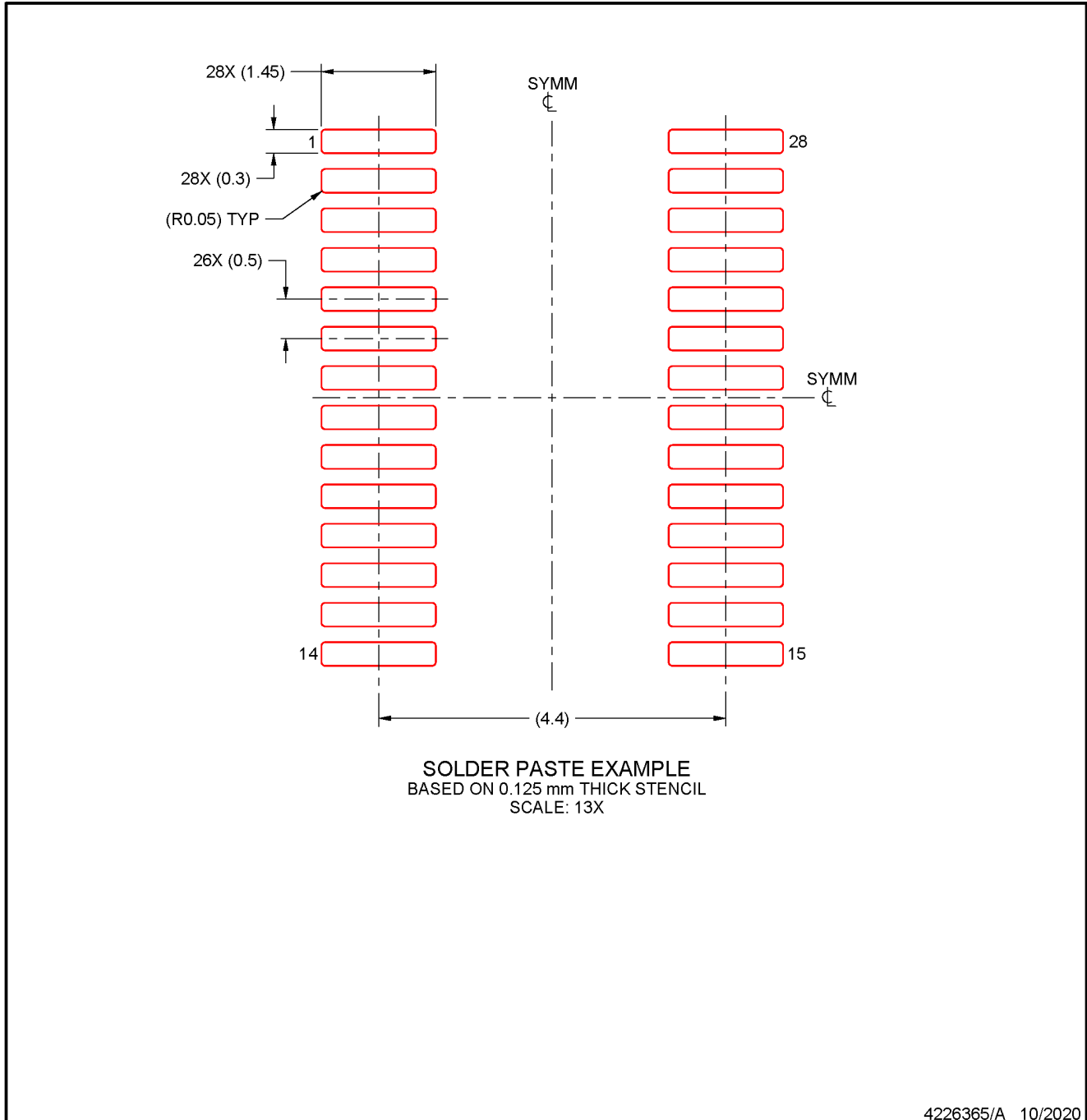

NOTES: (continued)

11. Laser cutting apertures with trapezoidal walls and rounded corners may offer better paste release. IPC-7525 may have alternate design recommendations.
12. Board assembly site may have different recommendations for stencil design.

**RGE 24**

**GENERIC PACKAGE VIEW**

**VQFN - 1 mm max height**

PLASTIC QUAD FLATPACK - NO LEAD

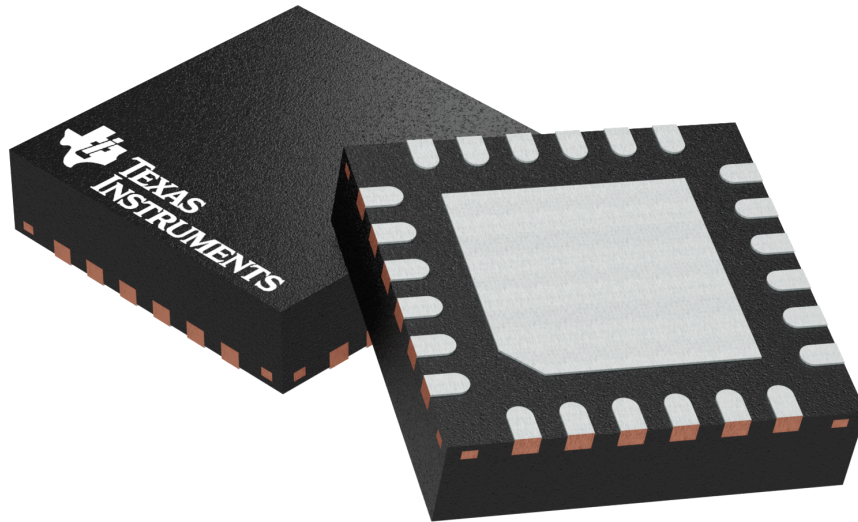

Images above are just a representation of the package family, actual package may vary.  
Refer to the product data sheet for package details.

4204104/H



# RGE0024B

# PACKAGE OUTLINE

## VQFN - 1 mm max height

PLASTIC QUAD FLATPACK - NO LEAD

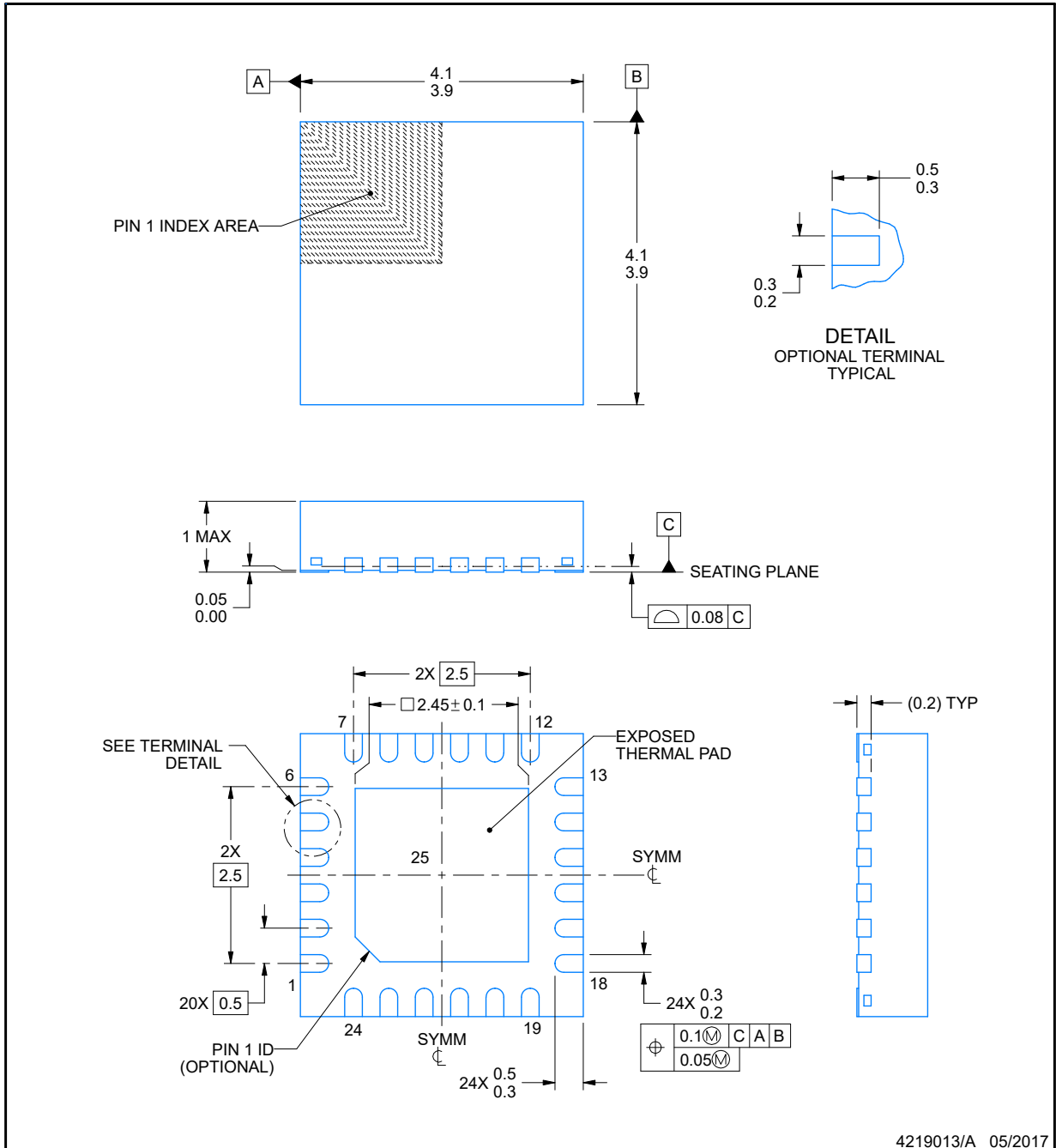

**NOTES:**

1. All linear dimensions are in millimeters. Any dimensions in parenthesis are for reference only. Dimensioning and tolerancing per ASME Y14.5M.
2. This drawing is subject to change without notice.
3. The package thermal pad must be soldered to the printed circuit board for thermal and mechanical performance.

## EXAMPLE BOARD LAYOUT

**RGE0024B**

**VQFN - 1 mm max height**

PLASTIC QUAD FLATPACK - NO LEAD

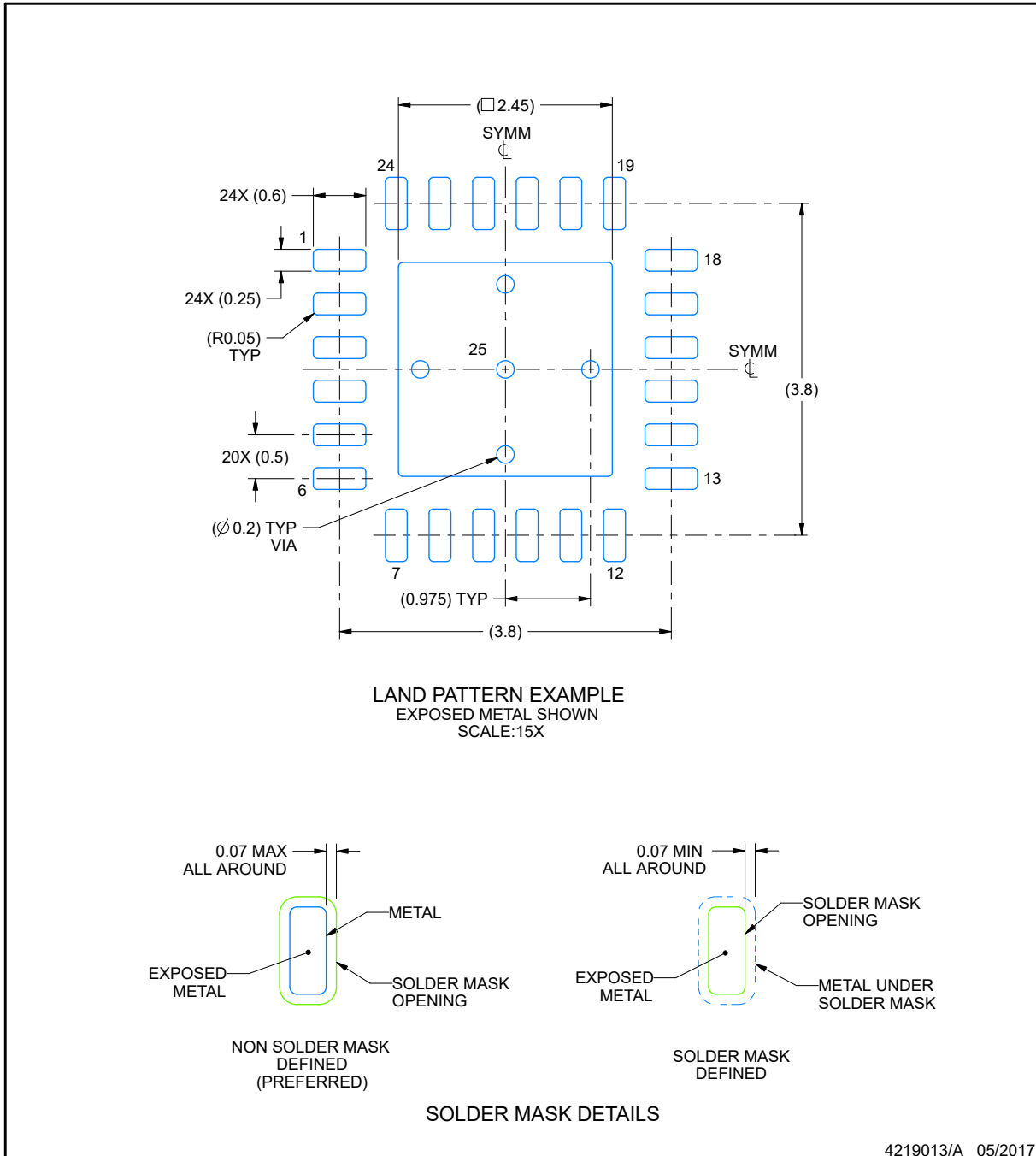

NOTES: (continued)

4. This package is designed to be soldered to a thermal pad on the board. For more information, see Texas Instruments literature number SLUA271 ([www.ti.com/lit/sluea271](http://www.ti.com/lit/sluea271)).
5. Vias are optional depending on application, refer to device data sheet. If any vias are implemented, refer to their locations shown on this view. It is recommended that vias under paste be filled, plugged or tented.

## EXAMPLE STENCIL DESIGN

**RGE0024B**

**VQFN - 1 mm max height**

PLASTIC QUAD FLATPACK - NO LEAD

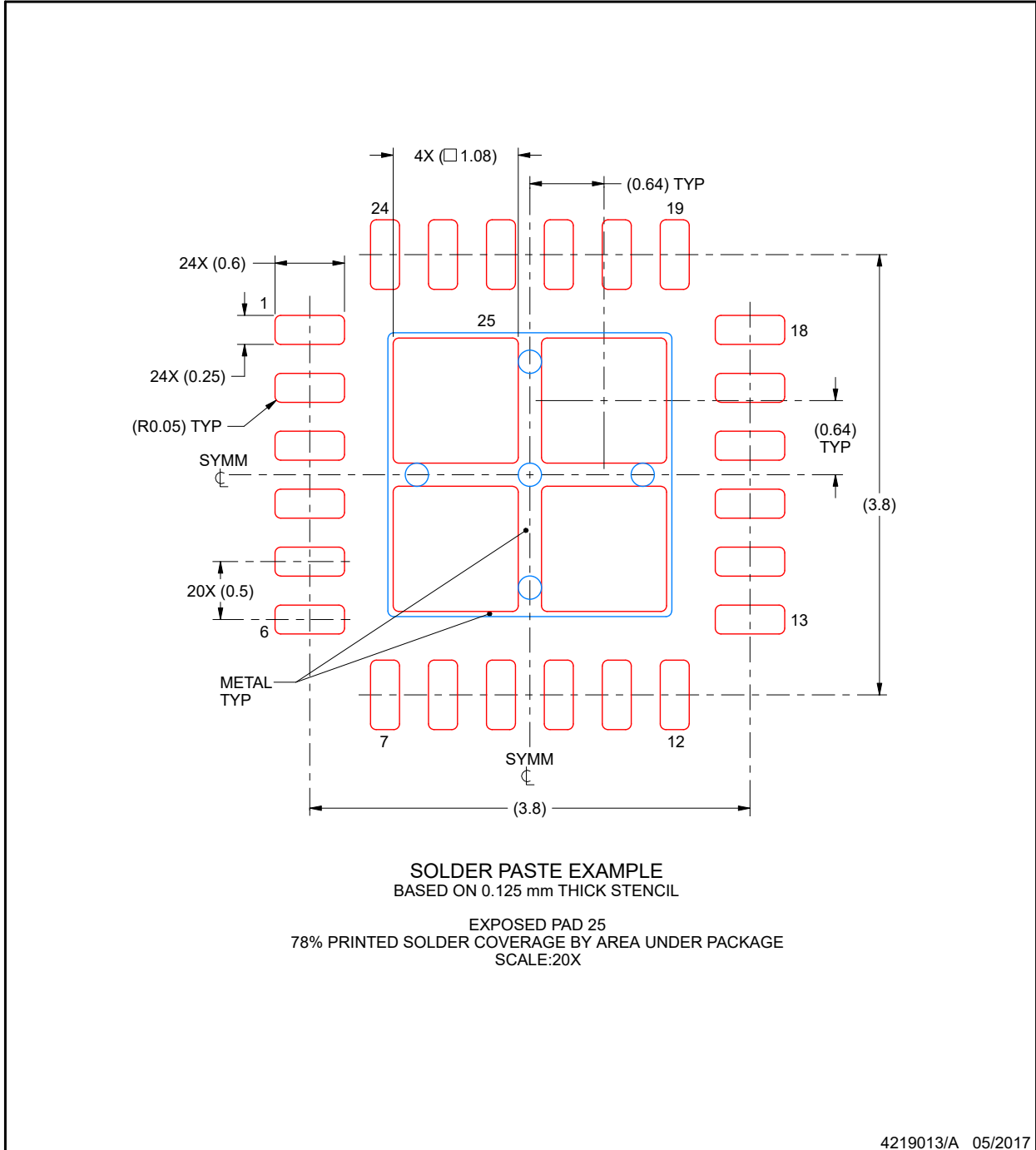

NOTES: (continued)

6. Laser cutting apertures with trapezoidal walls and rounded corners may offer better paste release. IPC-7525 may have alternate design recommendations.

# DGS0020A



# PACKAGE OUTLINE

## VSSOP - 1.1 mm max height

SMALL OUTLINE PACKAGE

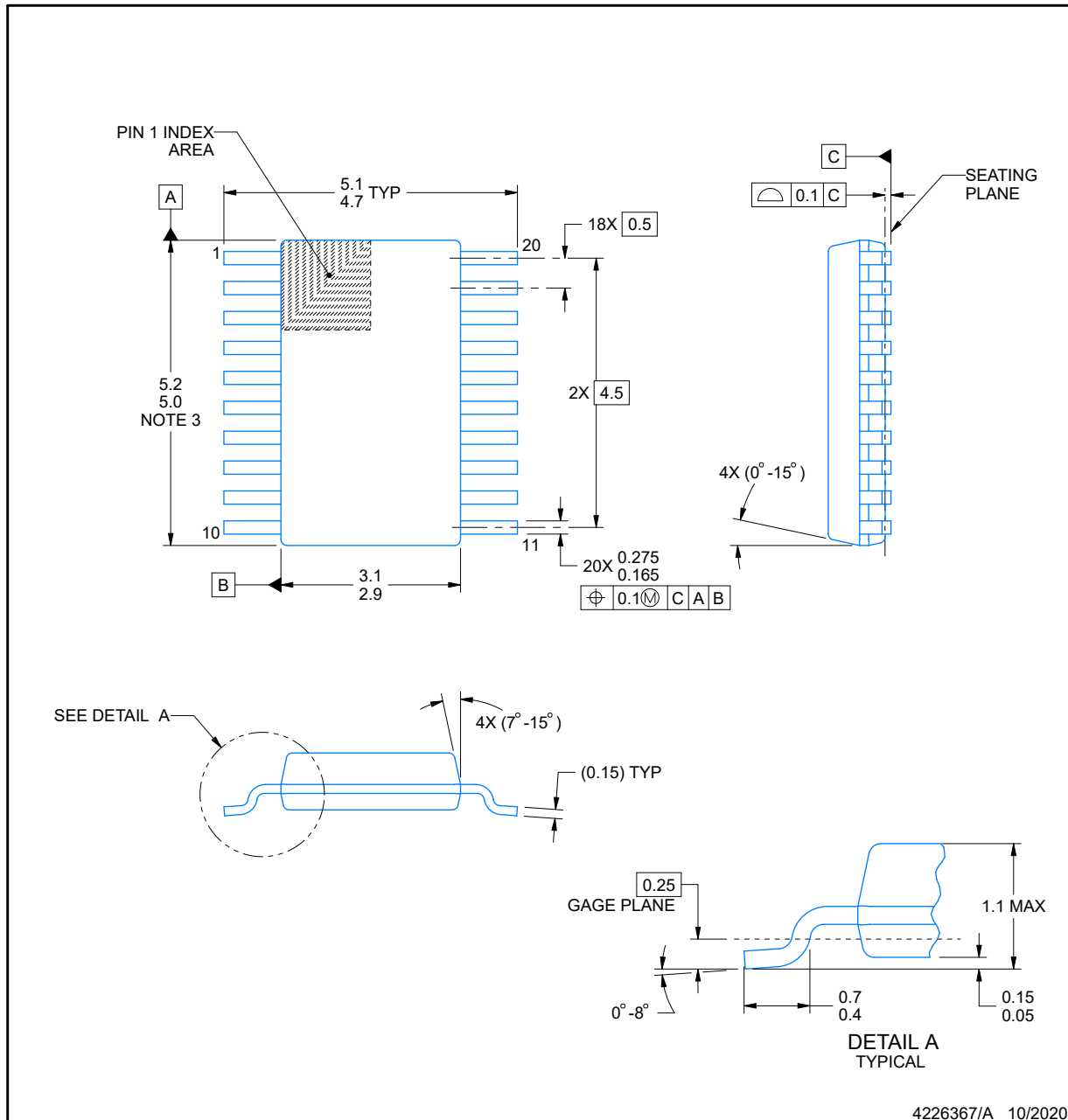

**NOTES:**

PowerPAD is a trademark of Texas Instruments.

1. All linear dimensions are in millimeters. Any dimensions in parenthesis are for reference only. Dimensioning and tolerancing per ASME Y14.5M.
2. This drawing is subject to change without notice.
3. This dimension does not include mold flash, protrusions, or gate burrs. Mold flash, protrusions, or gate burrs shall not exceed 0.15 mm per side.
4. No JEDEC registration as of September 2020.
5. Features may differ or may not be present.

## EXAMPLE BOARD LAYOUT

**DGS0020A**

**VSSOP - 1.1 mm max height**

SMALL OUTLINE PACKAGE

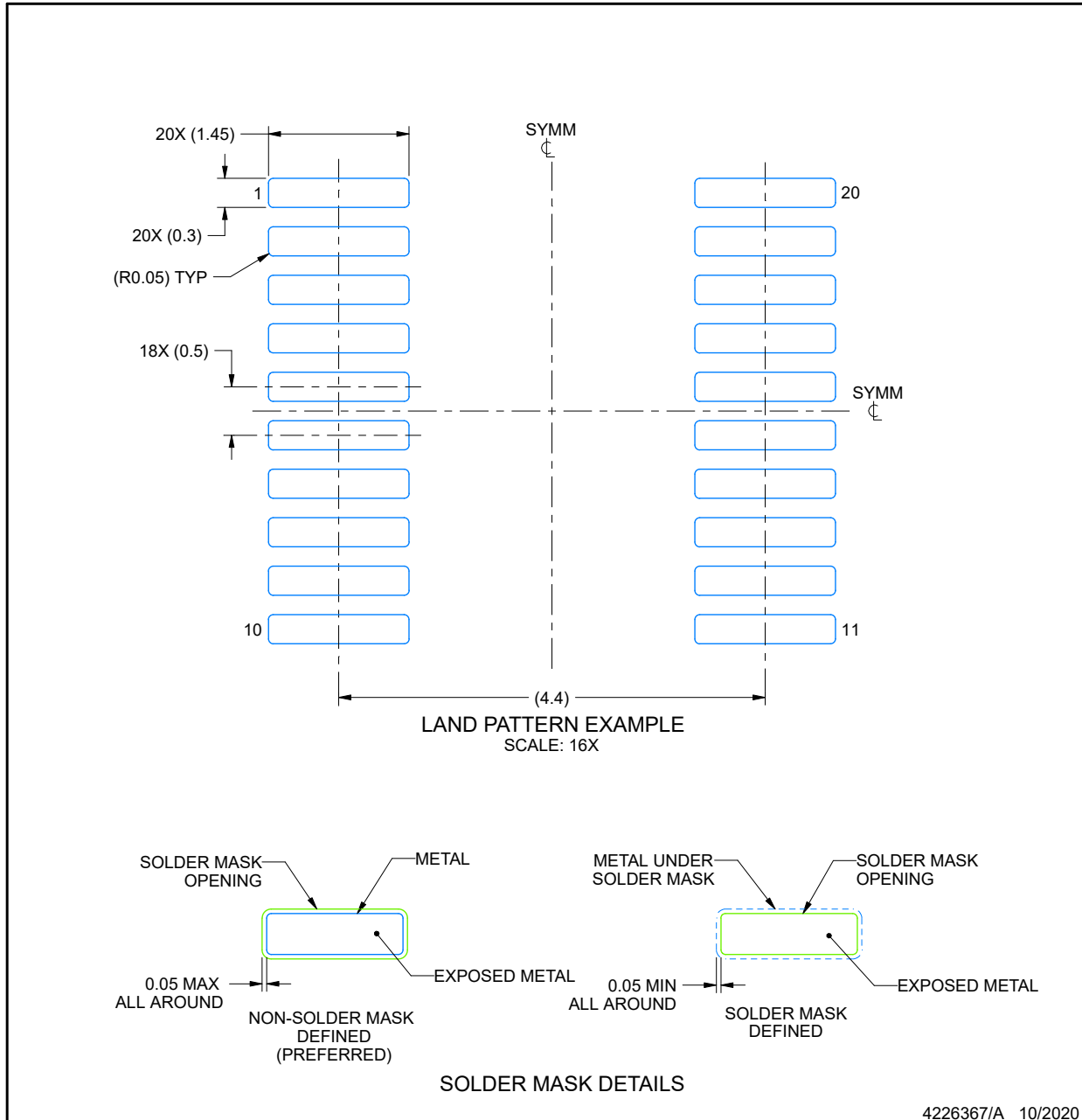

4226367/A 10/2020

NOTES: (continued)

6. Publication IPC-7351 may have alternate designs.
7. Solder mask tolerances between and around signal pads can vary based on board fabrication site.
8. This package is designed to be soldered to a thermal pad on the board. For more information, see Texas Instruments literature numbers SLMA002 ([www.ti.com/lit/slma002](http://www.ti.com/lit/slma002)) and SLMA004 ([www.ti.com/lit/slma004](http://www.ti.com/lit/slma004)).
9. Size of metal pad may vary due to creepage requirement.
10. Vias are optional depending on application, refer to device data sheet. It is recommended that vias under paste be filled, plugged or tented.

## EXAMPLE STENCIL DESIGN

### DGS0020A

### VSSOP - 1.1 mm max height

SMALL OUTLINE PACKAGE

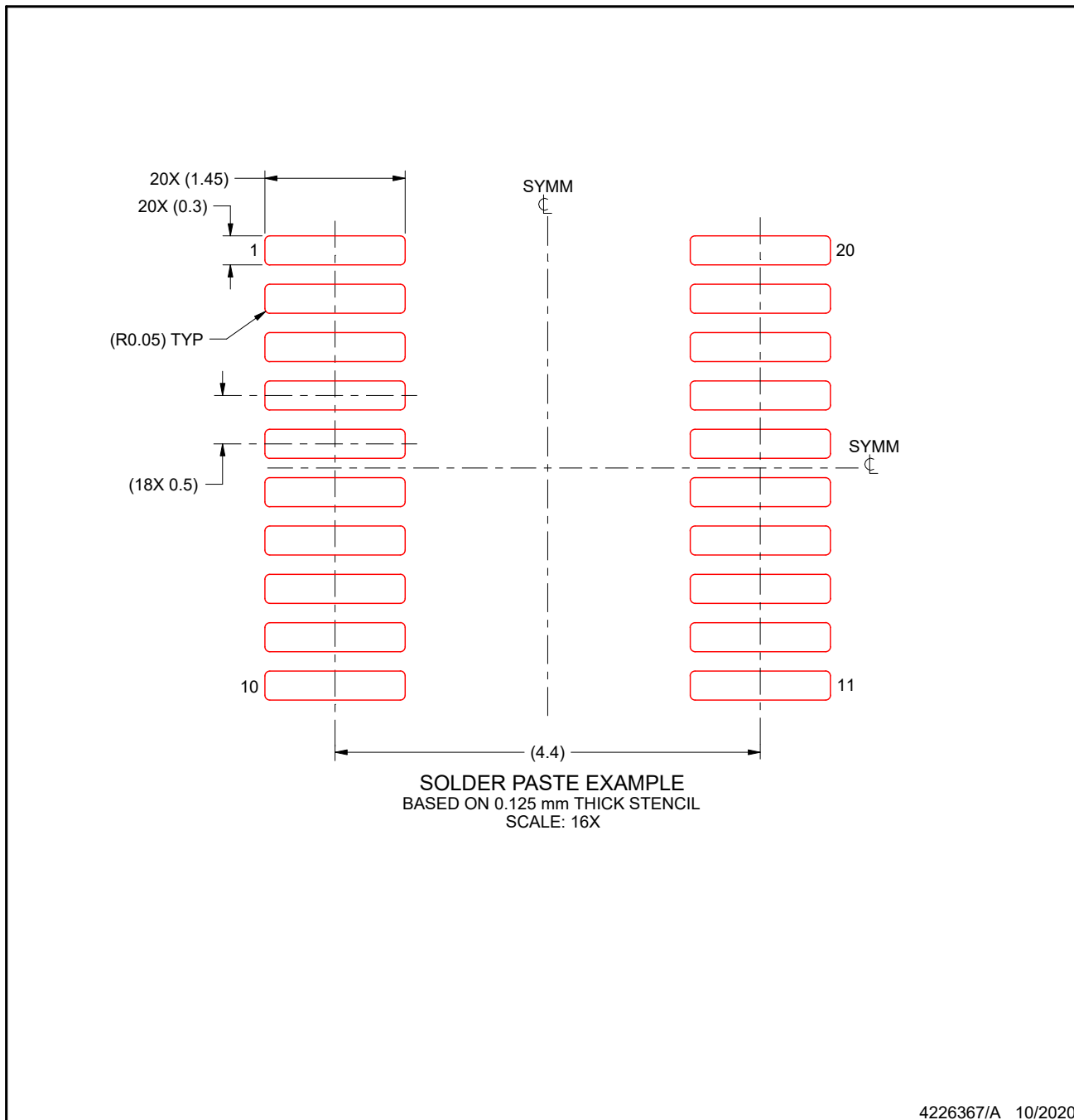

NOTES: (continued)

- 11. Laser cutting apertures with trapezoidal walls and rounded corners may offer better paste release. IPC-7525 may have alternate design recommendations.
- 12. Board assembly site may have different recommendations for stencil design.

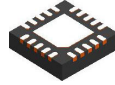

**RUK0020B**

**PACKAGE OUTLINE**  
**WQFN - 0.8 mm max height**

PLASTIC QUAD FLATPACK - NO LEAD

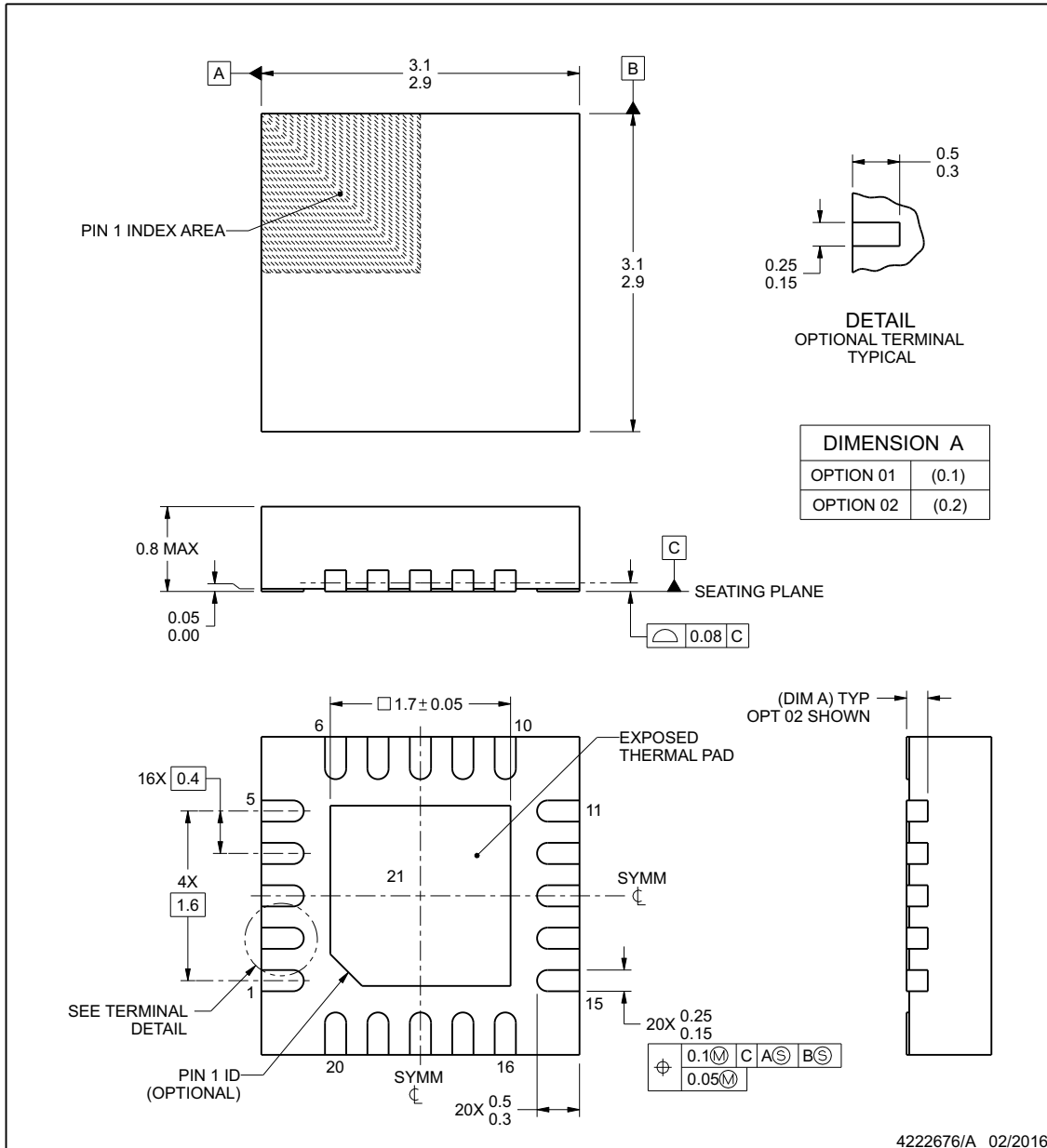

**NOTES:**

1. All linear dimensions are in millimeters. Any dimensions in parenthesis are for reference only. Dimensioning and tolerancing per ASME Y14.5M.
2. This drawing is subject to change without notice.
3. The package thermal pad must be soldered to the printed circuit board for thermal and mechanical performance.

## EXAMPLE BOARD LAYOUT

**RUK0020B**

**WQFN - 0.8 mm max height**

PLASTIC QUAD FLATPACK - NO LEAD

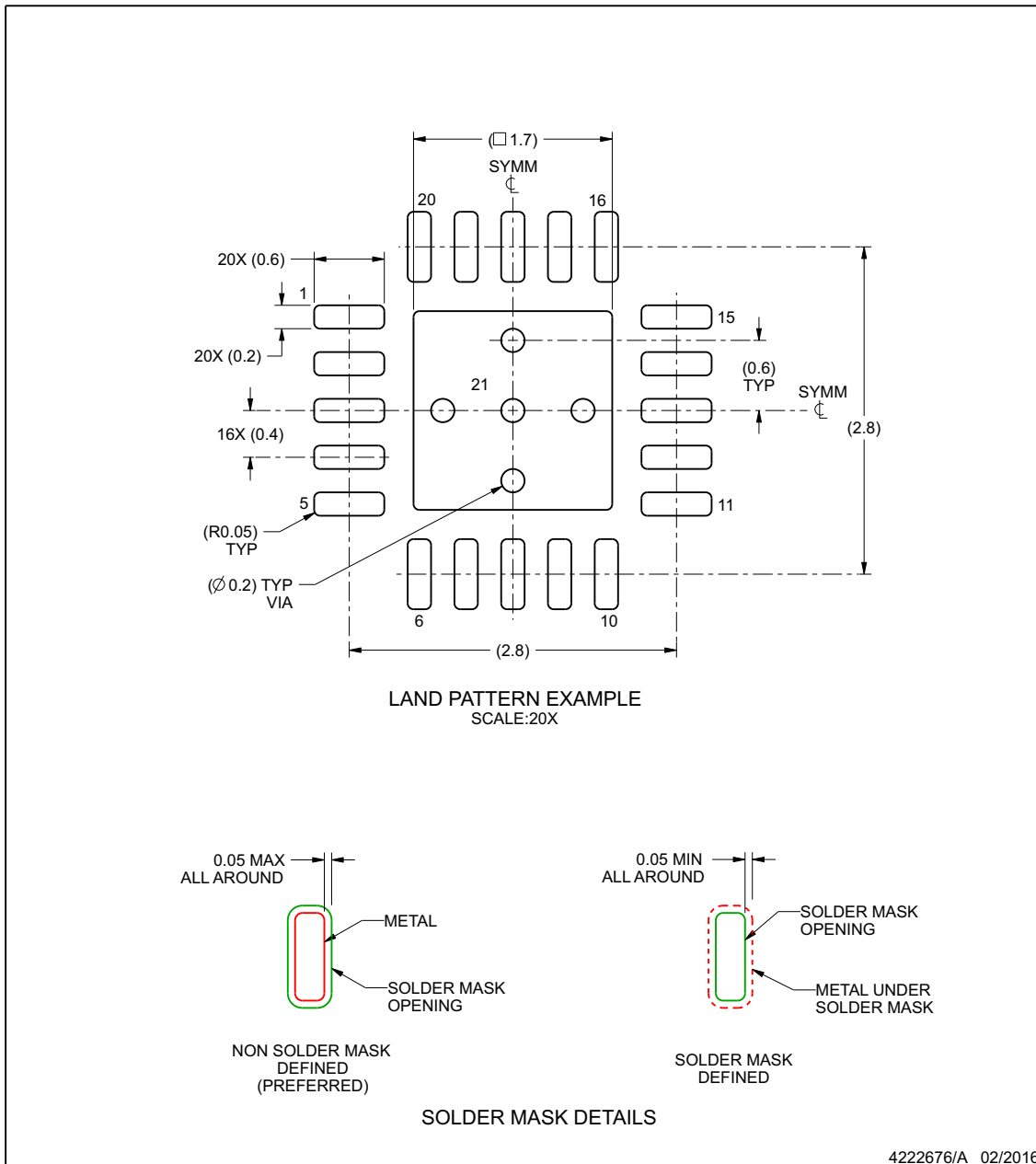

NOTES: (continued)

4. This package is designed to be soldered to a thermal pad on the board. For more information, see Texas Instruments literature number SLUA271 ([www.ti.com/lit/slua271](http://www.ti.com/lit/slua271)).
5. Vias are optional depending on application, refer to device data sheet. If any vias are implemented, refer to their locations shown on this view. It is recommended that vias under paste be filled, plugged or tented.

[www.ti.com](http://www.ti.com)

## EXAMPLE STENCIL DESIGN

**RUK0020B**

**WQFN - 0.8 mm max height**

PLASTIC QUAD FLATPACK - NO LEAD

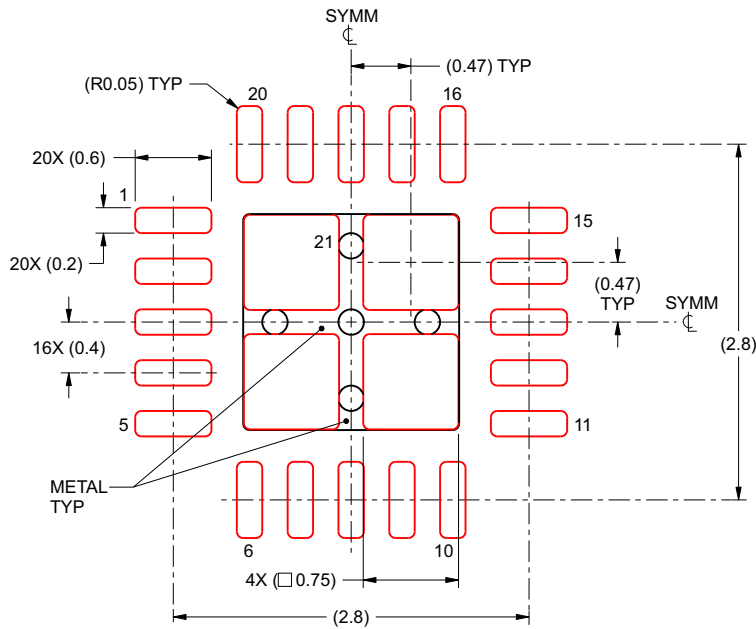

**SOLDER PASTE EXAMPLE**  
 BASED ON 0.1 mm THICK STENCIL

EXPOSED PAD 21:  
 78% PRINTED SOLDER COVERAGE BY AREA UNDER PACKAGE  
 SCALE:20X

4222676/A 02/2016

NOTES: (continued)

6. Laser cutting apertures with trapezoidal walls and rounded corners may offer better paste release. IPC-7525 may have alternate design recommendations.

www.ti.com

**PACKAGING INFORMATION**

Orderable part number	Status (1)	Material type (2)	Package   Pins	Package qty   Carrier	RoHS (3)	Lead finish/ Ball material (4)	MSL rating/ Peak reflow (5)	Op temp (°C)	Part marking (6)
<a href="#">MSP32C031C6SPTR</a>	Active	Production	LQFP (PT)   48	1000   LARGE T&R	Yes	NIPDAU	Level-2-260C-1 YEAR	-40 to 125	M0C031C6S
<a href="#">MSP32G031C6SPTR</a>	Active	Production	LQFP (PT)   48	1000   LARGE T&R	Yes	NIPDAU	Level-2-260C-1 YEAR	-40 to 125	M0G031C6S
<a href="#">MSP32G031C8SPTR</a>	Active	Production	LQFP (PT)   48	1000   LARGE T&R	Yes	NIPDAU	Level-2-260C-1 YEAR	-40 to 125	M0G031C8S
<a href="#">MSPM0C1105SDGS20R</a>	Active	Production	VSSOP (DGS)   20	5000   LARGE T&R	Yes	NIPDAU	Level-2-260C-1 YEAR	-40 to 125	M0C1105S
<a href="#">MSPM0C1105SDGS28R</a>	Active	Production	VSSOP (DGS)   28	5000   LARGE T&R	Yes	NIPDAU	Level-2-260C-1 YEAR	-40 to 125	C1105S
<a href="#">MSPM0C1105SPTR</a>	Active	Production	LQFP (PT)   48	1000   LARGE T&R	Yes	NIPDAU	Level-2-260C-1 YEAR	-40 to 125	M0C1105S
<a href="#">MSPM0C1105SRGER</a>	Active	Production	VQFN (RGE)   24	5000   LARGE T&R	Yes	NIPDAU	Level-1-260C-UNLIM	-40 to 125	MSPM0 C1105S
<a href="#">MSPM0C1105SRGZR</a>	Active	Production	VQFN (RGZ)   48	4000   LARGE T&R	Yes	NIPDAU	Level-2-260C-1 YEAR	-40 to 125	MSPM0 C1105S
<a href="#">MSPM0C1105SRHBR</a>	Active	Production	VQFN (RHB)   32	5000   LARGE T&R	Yes	NIPDAU	Level-2-260C-1 YEAR	-40 to 125	MSPM0 C1105S
<a href="#">MSPM0C1105SRUKR</a>	Active	Production	WQFN (RUK)   20	5000   LARGE T&R	Yes	NIPDAU	Level-1-260C-UNLIM	-40 to 125	C1105S
<a href="#">MSPM0C1105SZCMR</a>	Active	Production	NFBGA (ZCM)   48	2500   LARGE T&R	Yes	SNAGCU	Level-2-260C-1 YEAR	-40 to 125	M0C1105S
<a href="#">MSPM0C1106SDGS20R</a>	Active	Production	VSSOP (DGS)   20	5000   LARGE T&R	Yes	NIPDAU	Level-2-260C-1 YEAR	-40 to 125	M0C1106S
<a href="#">MSPM0C1106SDGS28R</a>	Active	Production	VSSOP (DGS)   28	5000   LARGE T&R	Yes	NIPDAU	Level-2-260C-1 YEAR	-40 to 125	C1106S
<a href="#">MSPM0C1106SPTR</a>	Active	Production	LQFP (PT)   48	1000   LARGE T&R	Yes	NIPDAU	Level-2-260C-1 YEAR	-40 to 125	M0C1106S
<a href="#">MSPM0C1106SRGER</a>	Active	Production	VQFN (RGE)   24	5000   LARGE T&R	Yes	NIPDAU	Level-1-260C-UNLIM	-40 to 125	MSPM0 C1106S
<a href="#">MSPM0C1106SRGZR</a>	Active	Production	VQFN (RGZ)   48	4000   LARGE T&R	Yes	NIPDAU	Level-2-260C-1 YEAR	-40 to 125	MSPM0 C1106S
<a href="#">MSPM0C1106SRHBR</a>	Active	Production	VQFN (RHB)   32	5000   LARGE T&R	Yes	NIPDAU	Level-2-260C-1 YEAR	-40 to 125	MSPM0 C1106S
<a href="#">MSPM0C1106SRUKR</a>	Active	Production	WQFN (RUK)   20	5000   LARGE T&R	Yes	NIPDAU	Level-1-260C-UNLIM	-40 to 125	C1106S
<a href="#">MSPM0C1106SZCMR</a>	Active	Production	NFBGA (ZCM)   48	2500   LARGE T&R	Yes	SNAGCU	Level-2-260C-1 YEAR	-40 to 125	M0C1106S

(1) **Status:** For more details on status, see our [product life cycle](#).

(2) **Material type:** When designated, preproduction parts are prototypes/experimental devices, and are not yet approved or released for full production. Testing and final process, including without limitation quality assurance, reliability performance testing, and/or process qualification, may not yet be complete, and this item is subject to further changes or possible discontinuation. If available for ordering, purchases will be subject to an additional waiver at checkout, and are intended for early internal evaluation purposes only. These items are sold without warranties of any kind.

(3) **RoHS values:** Yes, No, RoHS Exempt. See the [TI RoHS Statement](#) for additional information and value definition.

(4) **Lead finish/Ball material:** Parts may have multiple material finish options. Finish options are separated by a vertical ruled line. Lead finish/Ball material values may wrap to two lines if the finish value exceeds the maximum column width.

(5) **MSL rating/Peak reflow:** The moisture sensitivity level ratings and peak solder (reflow) temperatures. In the event that a part has multiple moisture sensitivity ratings, only the lowest level per JEDEC standards is shown. Refer to the shipping label for the actual reflow temperature that will be used to mount the part to the printed circuit board.

(6) **Part marking:** There may be an additional marking, which relates to the logo, the lot trace code information, or the environmental category of the part.

Multiple part markings will be inside parentheses. Only one part marking contained in parentheses and separated by a "~" will appear on a part. If a line is indented then it is a continuation of the previous line and the two combined represent the entire part marking for that device.

**Important Information and Disclaimer:** The information provided on this page represents TI's knowledge and belief as of the date that it is provided. TI bases its knowledge and belief on information provided by third parties, and makes no representation or warranty as to the accuracy of such information. Efforts are underway to better integrate information from third parties. TI has taken and continues to take reasonable steps to provide representative and accurate information but may not have conducted destructive testing or chemical analysis on incoming materials and chemicals. TI and TI suppliers consider certain information to be proprietary, and thus CAS numbers and other limited information may not be available for release.

In no event shall TI's liability arising out of such information exceed the total purchase price of the TI part(s) at issue in this document sold by TI to Customer on an annual basis.

**OTHER QUALIFIED VERSIONS OF MSPM0C1105, MSPM0C1106 :**

- Automotive : [MSPM0C1105-Q1](#), [MSPM0C1106-Q1](#)

NOTE: Qualified Version Definitions:

- Automotive - Q100 devices qualified for high-reliability automotive applications targeting zero defects

## TAPE AND REEL INFORMATION

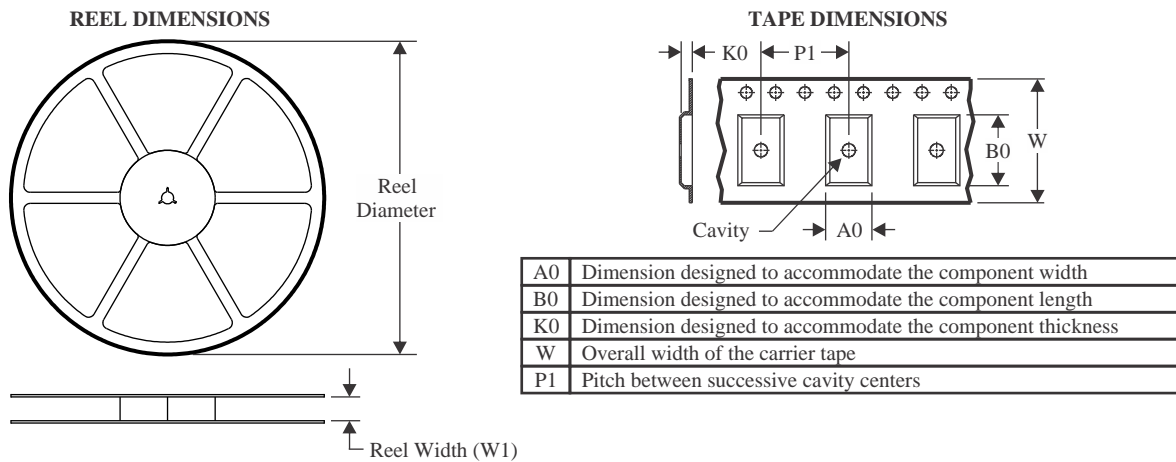

### QUADRANT ASSIGNMENTS FOR PIN 1 ORIENTATION IN TAPE

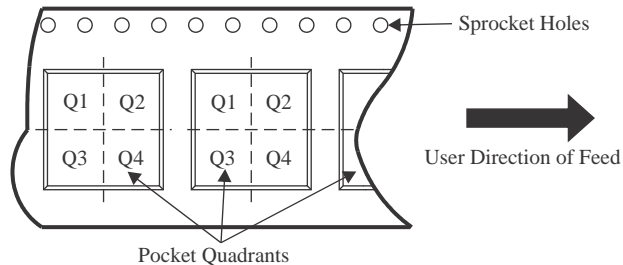

\*All dimensions are nominal

Device	Package Type	Package Drawing	Pins	SPQ	Reel Diameter (mm)	Reel Width W1 (mm)	A0 (mm)	B0 (mm)	K0 (mm)	P1 (mm)	W (mm)	Pin1 Quadrant
MSP32C031C6SPTR	LQFP	PT	48	1000	330.0	16.4	9.6	9.6	1.9	12.0	16.0	Q2
MSP32G031C6SPTR	LQFP	PT	48	1000	330.0	16.4	9.6	9.6	1.9	12.0	16.0	Q2
MSP32G031C8SPTR	LQFP	PT	48	1000	330.0	16.4	9.6	9.6	1.9	12.0	16.0	Q2
MSPM0C1105SDGS20R	VSSOP	DGS	20	5000	330.0	16.4	5.4	5.4	1.45	8.0	16.0	Q1
MSPM0C1105SDGS28R	VSSOP	DGS	28	5000	330.0	16.4	5.5	7.4	1.45	8.0	16.0	Q1
MSPM0C1105SPTR	LQFP	PT	48	1000	330.0	16.4	9.6	9.6	1.9	12.0	16.0	Q2
MSPM0C1105SRGER	VQFN	RGE	24	5000	330.0	12.4	4.25	4.25	1.15	8.0	12.0	Q2
MSPM0C1105SRGZR	VQFN	RGZ	48	4000	330.0	16.4	7.3	7.3	1.1	12.0	16.0	Q2
MSPM0C1105SRHBR	VQFN	RHB	32	5000	330.0	12.4	5.3	5.3	1.1	8.0	12.0	Q2
MSPM0C1105SRUKR	WQFN	RUK	20	5000	330.0	12.4	3.3	3.3	1.1	8.0	12.0	Q2
MSPM0C1105SZCMR	NFBGA	ZCM	48	2500	330.0	12.4	3.7	3.7	1.4	8.0	12.0	Q1
MSPM0C1106SDGS20R	VSSOP	DGS	20	5000	330.0	16.4	5.4	5.4	1.45	8.0	16.0	Q1
MSPM0C1106SDGS28R	VSSOP	DGS	28	5000	330.0	16.4	5.5	7.4	1.45	8.0	16.0	Q1
MSPM0C1106SPTR	LQFP	PT	48	1000	330.0	16.4	9.6	9.6	1.9	12.0	16.0	Q2
MSPM0C1106SRGER	VQFN	RGE	24	5000	330.0	12.4	4.25	4.25	1.15	8.0	12.0	Q2
MSPM0C1106SRGZR	VQFN	RGZ	48	4000	330.0	16.4	7.3	7.3	1.1	12.0	16.0	Q2

Device	Package Type	Package Drawing	Pins	SPQ	Reel Diameter (mm)	Reel Width W1 (mm)	A0 (mm)	B0 (mm)	K0 (mm)	P1 (mm)	W (mm)	Pin1 Quadrant
MSPM0C1106SRHBR	VQFN	RHB	32	5000	330.0	12.4	5.3	5.3	1.1	8.0	12.0	Q2
MSPM0C1106SRUKR	WQFN	RUK	20	5000	330.0	12.4	3.3	3.3	1.1	8.0	12.0	Q2
MSPM0C1106SZCMR	NFBGA	ZCM	48	2500	330.0	12.4	3.7	3.7	1.4	8.0	12.0	Q1

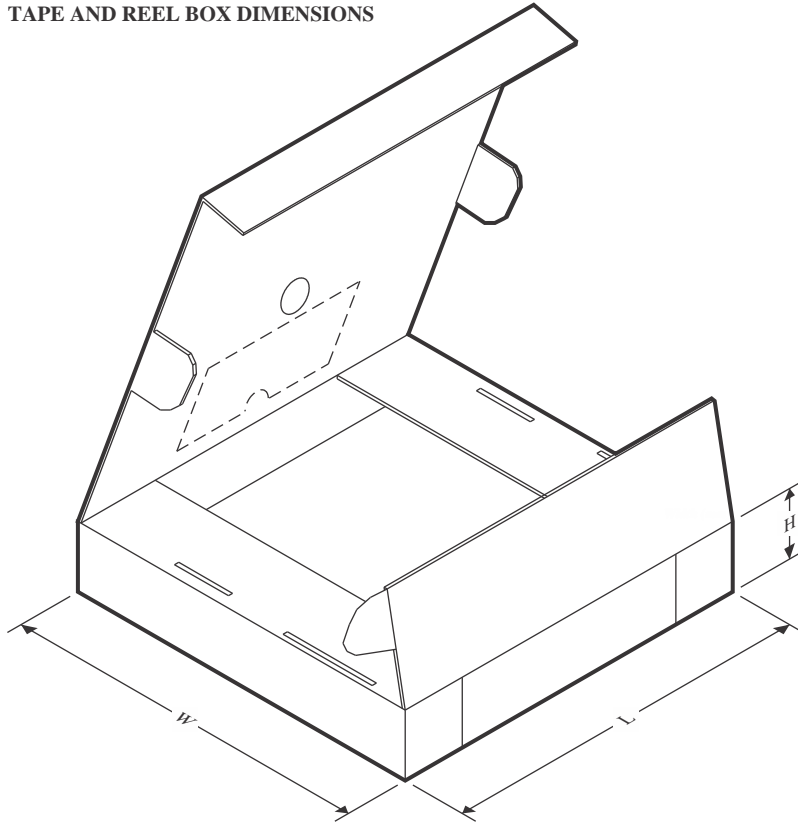
**TAPE AND REEL BOX DIMENSIONS**

\*All dimensions are nominal

Device	Package Type	Package Drawing	Pins	SPQ	Length (mm)	Width (mm)	Height (mm)
MSP32C031C6SPTR	LQFP	PT	48	1000	336.6	336.6	31.8
MSP32G031C6SPTR	LQFP	PT	48	1000	336.6	336.6	31.8
MSP32G031C8SPTR	LQFP	PT	48	1000	336.6	336.6	31.8
MSPM0C1105SDGS20R	VSSOP	DGS	20	5000	353.0	353.0	32.0
MSPM0C1105SDGS28R	VSSOP	DGS	28	5000	353.0	353.0	32.0
MSPM0C1105SPTR	LQFP	PT	48	1000	336.6	336.6	31.8
MSPM0C1105SRGER	VQFN	RGE	24	5000	367.0	367.0	35.0
MSPM0C1105SRGZR	VQFN	RGZ	48	4000	367.0	367.0	35.0
MSPM0C1105SRHBR	VQFN	RHB	32	5000	367.0	367.0	35.0
MSPM0C1105SRUKR	WQFN	RUK	20	5000	367.0	367.0	35.0
MSPM0C1105SZCMR	NFBGA	ZCM	48	2500	338.1	338.1	20.6
MSPM0C1106SDGS20R	VSSOP	DGS	20	5000	353.0	353.0	32.0
MSPM0C1106SDGS28R	VSSOP	DGS	28	5000	353.0	353.0	32.0
MSPM0C1106SPTR	LQFP	PT	48	1000	336.6	336.6	31.8
MSPM0C1106SRGER	VQFN	RGE	24	5000	367.0	367.0	35.0
MSPM0C1106SRGZR	VQFN	RGZ	48	4000	367.0	367.0	35.0
MSPM0C1106SRHBR	VQFN	RHB	32	5000	367.0	367.0	35.0
MSPM0C1106SRUKR	WQFN	RUK	20	5000	367.0	367.0	35.0

---

Device	Package Type	Package Drawing	Pins	SPQ	Length (mm)	Width (mm)	Height (mm)
MSPM0C1106SZCMR	NFBGA	ZCM	48	2500	338.1	338.1	20.6

**RGE 24**

**GENERIC PACKAGE VIEW**

**VQFN - 1 mm max height**

PLASTIC QUAD FLATPACK - NO LEAD

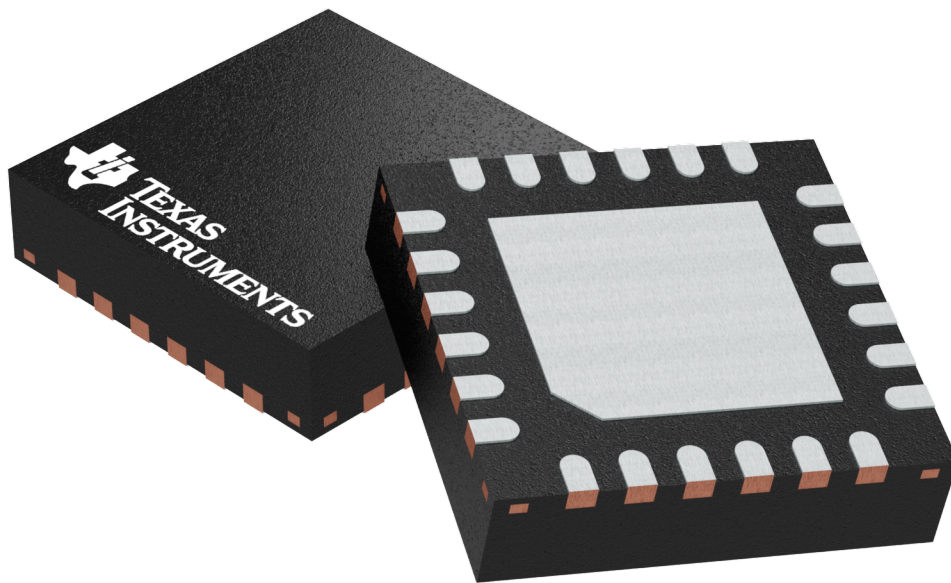

Images above are just a representation of the package family, actual package may vary.  
Refer to the product data sheet for package details.

4204104/H

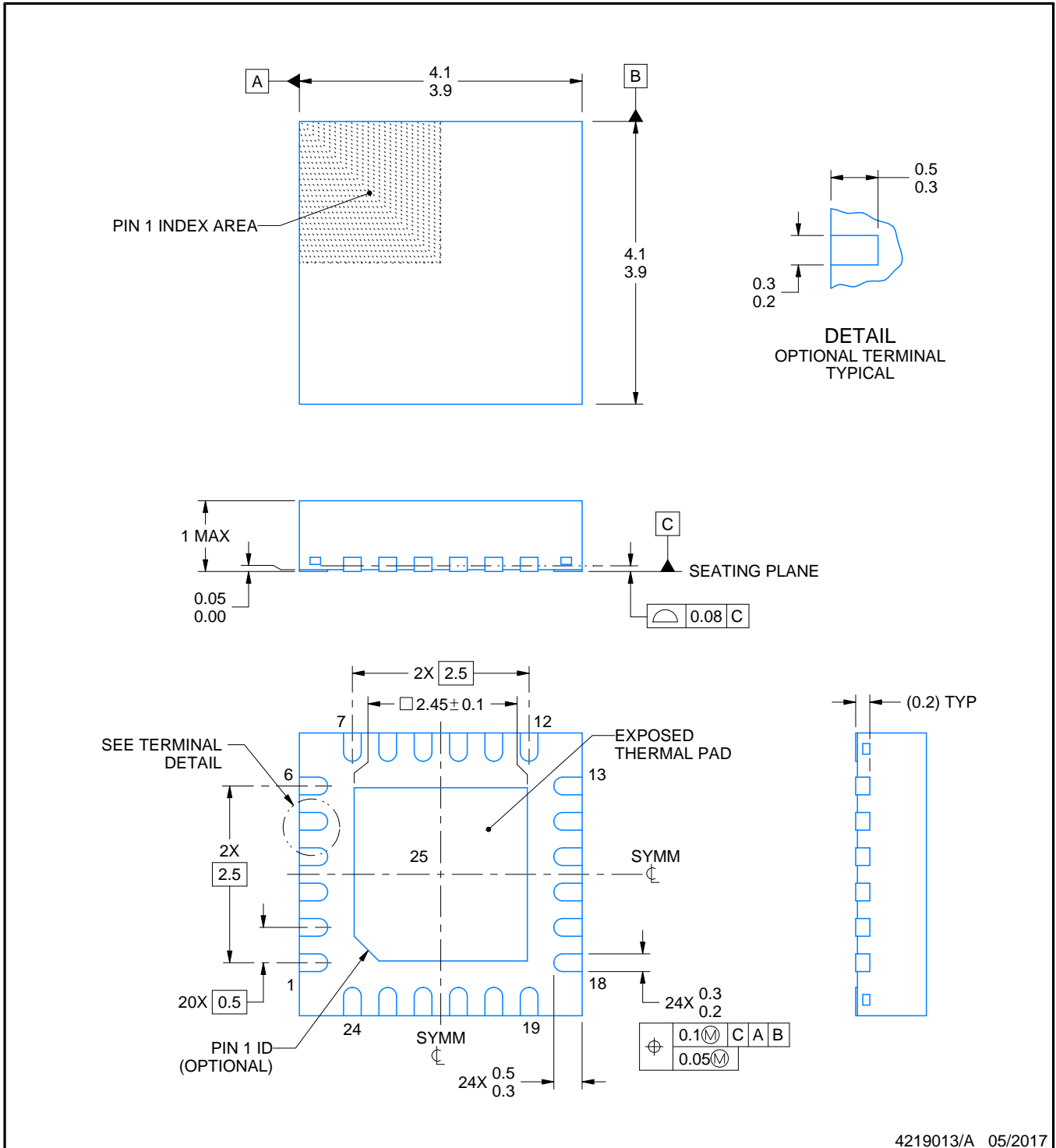
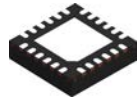

4219013/A 05/2017

NOTES:

1. All linear dimensions are in millimeters. Any dimensions in parenthesis are for reference only. Dimensioning and tolerancing per ASME Y14.5M.
2. This drawing is subject to change without notice.
3. The package thermal pad must be soldered to the printed circuit board for thermal and mechanical performance.



# EXAMPLE STENCIL DESIGN

RGE0024B

VQFN - 1 mm max height

PLASTIC QUAD FLATPACK - NO LEAD

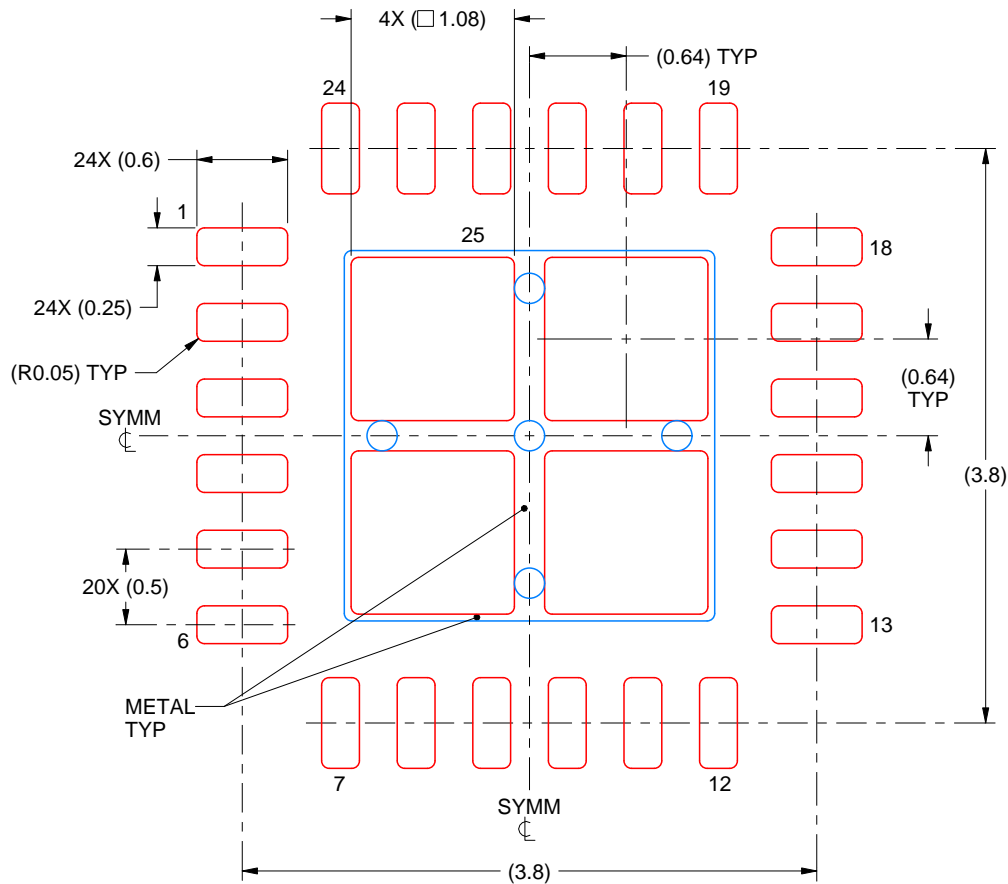

SOLDER PASTE EXAMPLE  
BASED ON 0.125 mm THICK STENCIL

EXPOSED PAD 25  
78% PRINTED SOLDER COVERAGE BY AREA UNDER PACKAGE  
SCALE:20X

4219013/A 05/2017

NOTES: (continued)

6. Laser cutting apertures with trapezoidal walls and rounded corners may offer better paste release. IPC-7525 may have alternate design recommendations.

## GENERIC PACKAGE VIEW

**RHB 32**

**VQFN - 1 mm max height**

5 x 5, 0.5 mm pitch

PLASTIC QUAD FLATPACK - NO LEAD

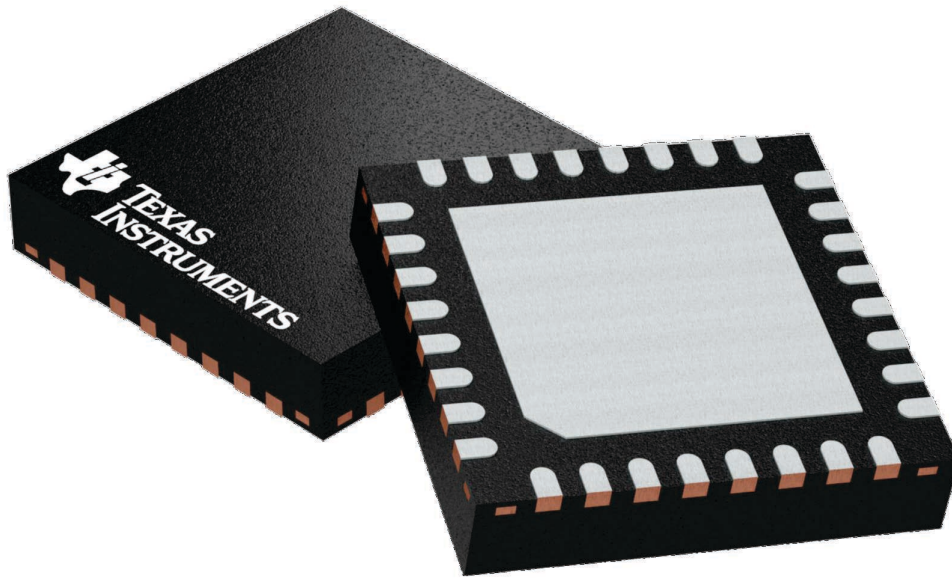

Images above are just a representation of the package family, actual package may vary.  
Refer to the product data sheet for package details.

4224745/A

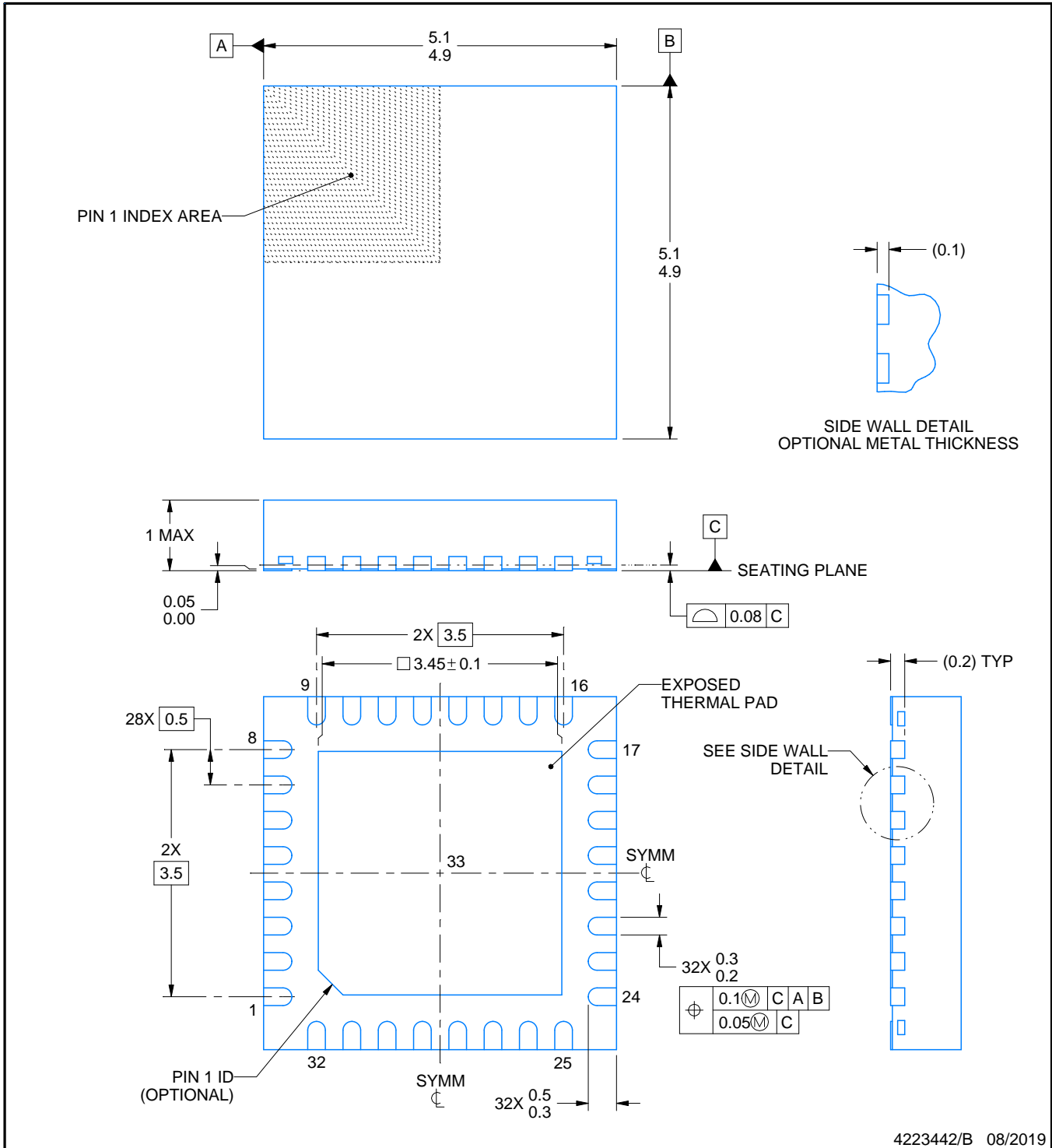
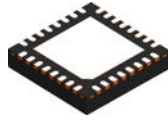

4223442/B 08/2019

NOTES:

1. All linear dimensions are in millimeters. Any dimensions in parenthesis are for reference only. Dimensioning and tolerancing per ASME Y14.5M.
2. This drawing is subject to change without notice.
3. The package thermal pad must be soldered to the printed circuit board for thermal and mechanical performance.

# EXAMPLE BOARD LAYOUT

RHB0032E

VQFN - 1 mm max height

PLASTIC QUAD FLATPACK - NO LEAD

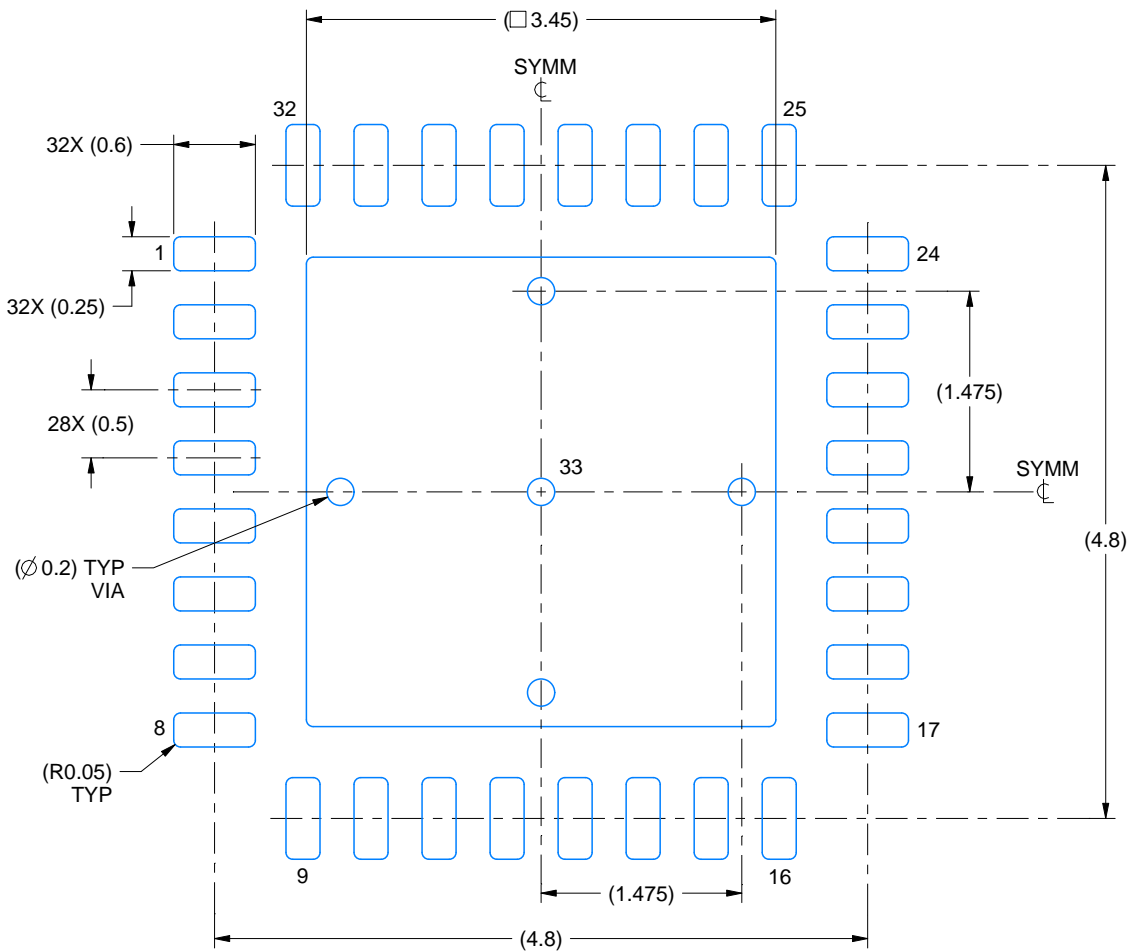

LAND PATTERN EXAMPLE  
SCALE:18X

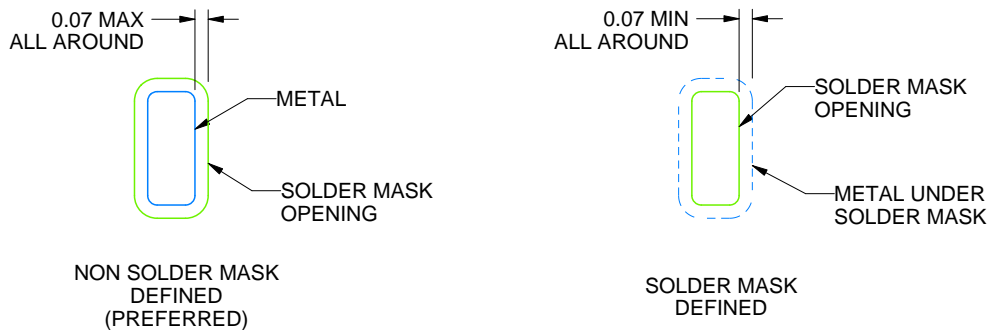

SOLDER MASK DETAILS

4223442/B 08/2019

NOTES: (continued)

- This package is designed to be soldered to a thermal pad on the board. For more information, see Texas Instruments literature number SLUA271 ([www.ti.com/lit/slua271](http://www.ti.com/lit/slua271)).
- Vias are optional depending on application, refer to device data sheet. If any vias are implemented, refer to their locations shown on this view. It is recommended that vias under paste be filled, plugged or tented.

# EXAMPLE STENCIL DESIGN

RHB0032E

VQFN - 1 mm max height

PLASTIC QUAD FLATPACK - NO LEAD

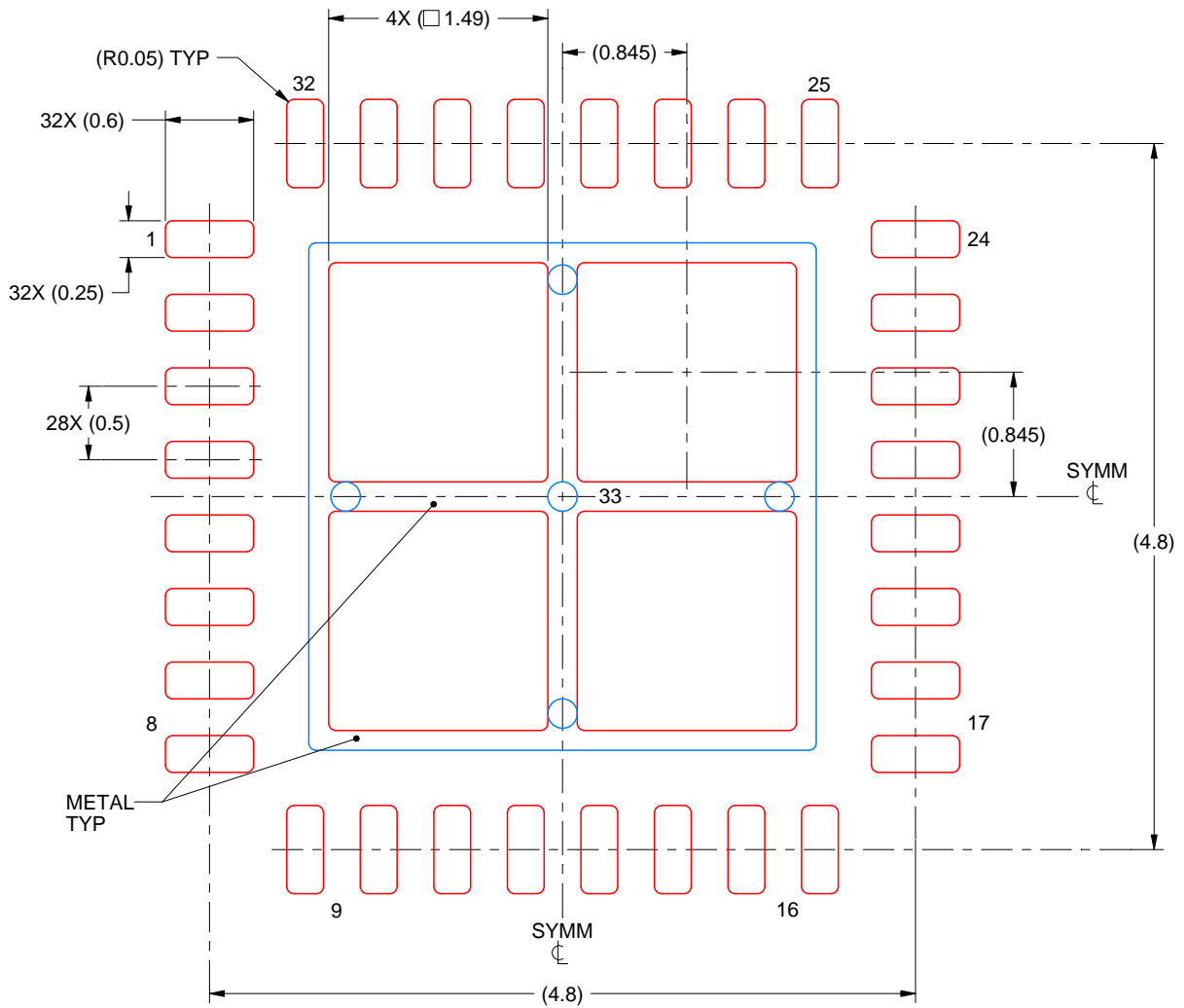

**SOLDER PASTE EXAMPLE**  
 BASED ON 0.125 mm THICK STENCIL

EXPOSED PAD 33:  
 75% PRINTED SOLDER COVERAGE BY AREA UNDER PACKAGE  
 SCALE:20X

4223442/B 08/2019

NOTES: (continued)

6. Laser cutting apertures with trapezoidal walls and rounded corners may offer better paste release. IPC-7525 may have alternate design recommendations.

# DGS0020A



# PACKAGE OUTLINE

VSSOP - 1.1 mm max height

SMALL OUTLINE PACKAGE

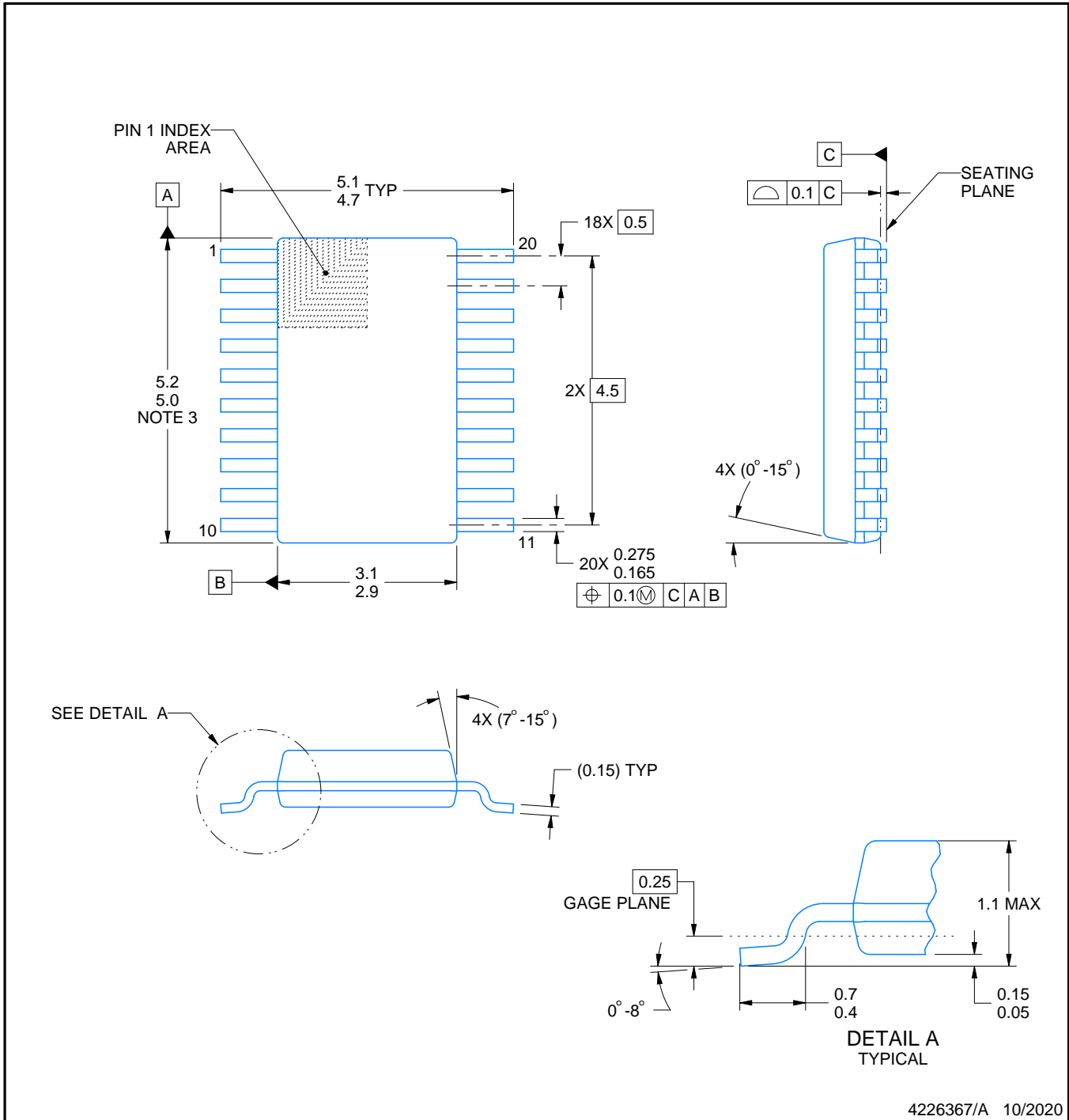

**NOTES:**

PowerPAD is a trademark of Texas Instruments.

1. All linear dimensions are in millimeters. Any dimensions in parenthesis are for reference only. Dimensioning and tolerancing per ASME Y14.5M.
2. This drawing is subject to change without notice.
3. This dimension does not include mold flash, protrusions, or gate burrs. Mold flash, protrusions, or gate burrs shall not exceed 0.15 mm per side.
4. No JEDEC registration as of September 2020.
5. Features may differ or may not be present.

# EXAMPLE BOARD LAYOUT

DGS0020A

VSSOP - 1.1 mm max height

SMALL OUTLINE PACKAGE

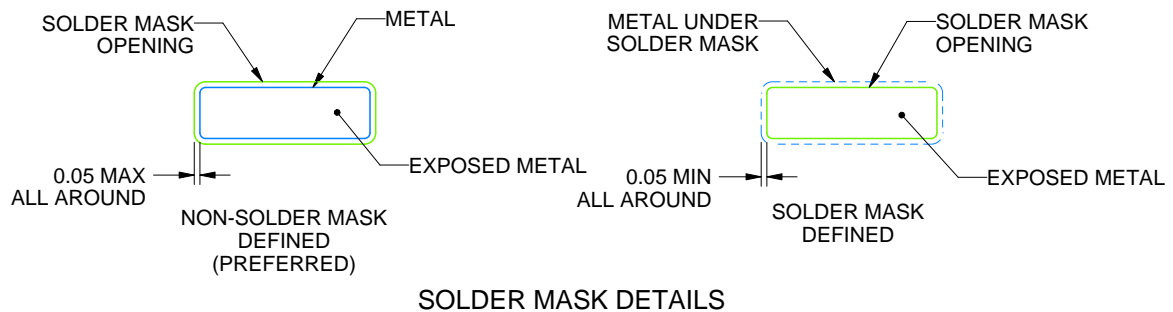
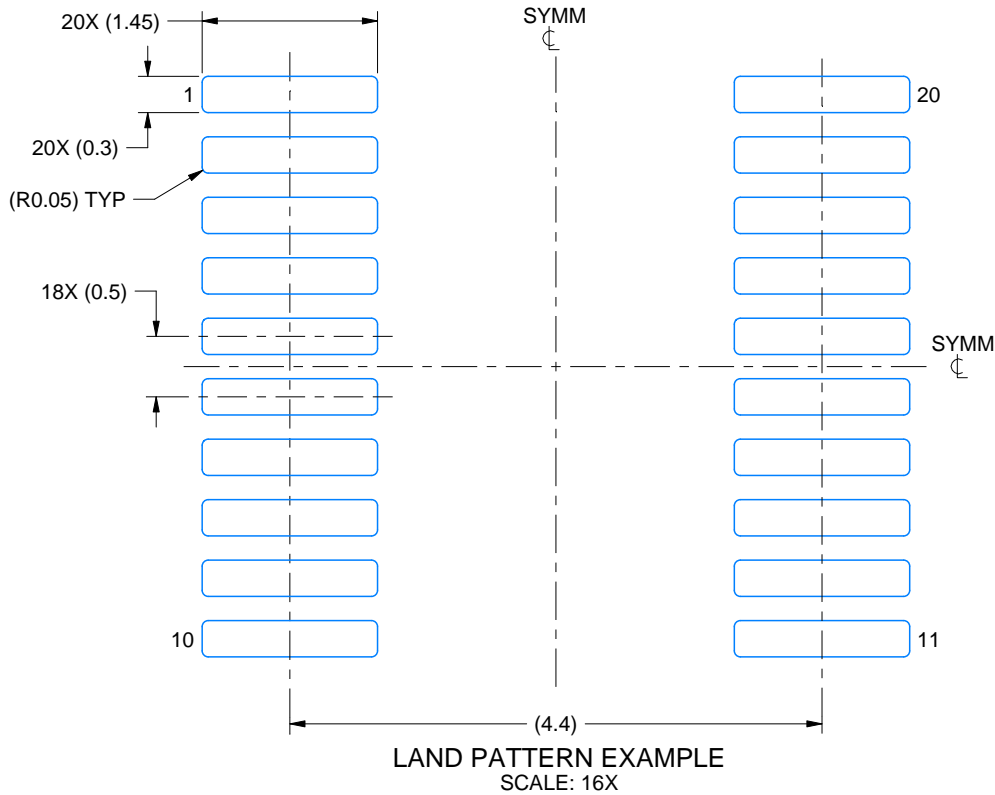

4226367/A 10/2020

NOTES: (continued)

6. Publication IPC-7351 may have alternate designs.
7. Solder mask tolerances between and around signal pads can vary based on board fabrication site.
8. This package is designed to be soldered to a thermal pad on the board. For more information, see Texas Instruments literature numbers SLMA002 ([www.ti.com/lit/slma002](http://www.ti.com/lit/slma002)) and SLMA004 ([www.ti.com/lit/slma004](http://www.ti.com/lit/slma004)).
9. Size of metal pad may vary due to creepage requirement.
10. Vias are optional depending on application, refer to device data sheet. It is recommended that vias under paste be filled, plugged or tented.

# EXAMPLE STENCIL DESIGN

DGS0020A

VSSOP - 1.1 mm max height

SMALL OUTLINE PACKAGE

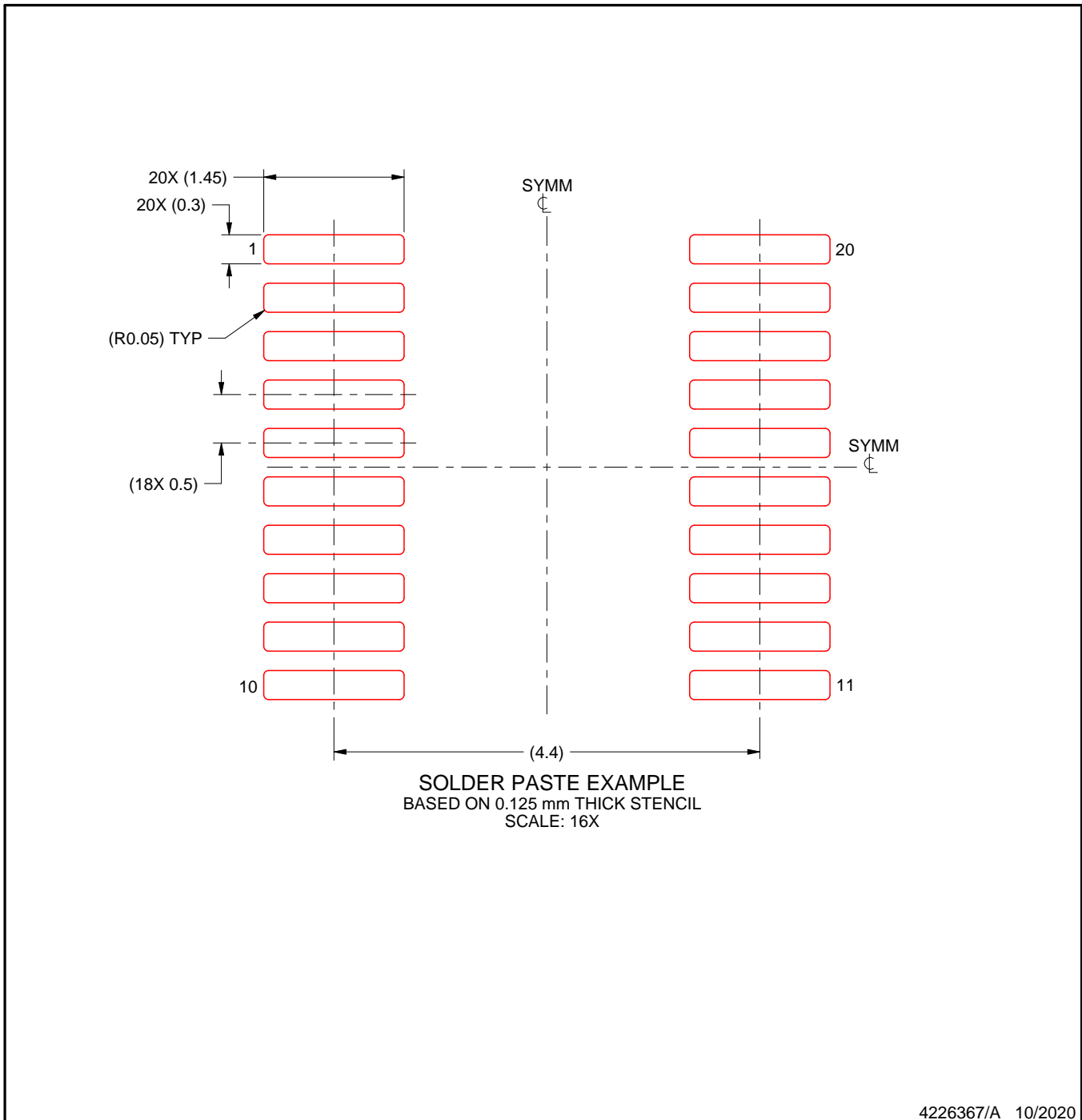

NOTES: (continued)

11. Laser cutting apertures with trapezoidal walls and rounded corners may offer better paste release. IPC-7525 may have alternate design recommendations.
12. Board assembly site may have different recommendations for stencil design.

## GENERIC PACKAGE VIEW

**RGZ 48**

**VQFN - 1 mm max height**

7 x 7, 0.5 mm pitch

PLASTIC QUADFLAT PACK- NO LEAD

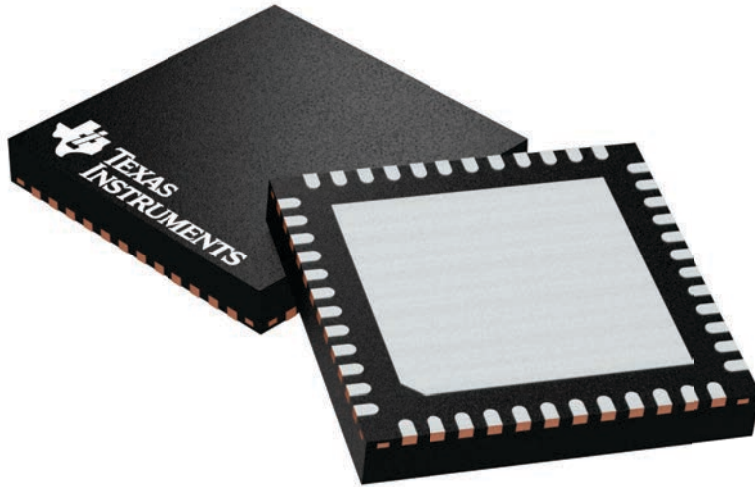

Images above are just a representation of the package family, actual package may vary.  
Refer to the product data sheet for package details.

4224671/A

RGZ0048B

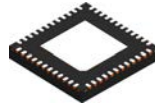

PACKAGE OUTLINE

VQFN - 1 mm max height

PLASTIC QUAD FLATPACK - NO LEAD

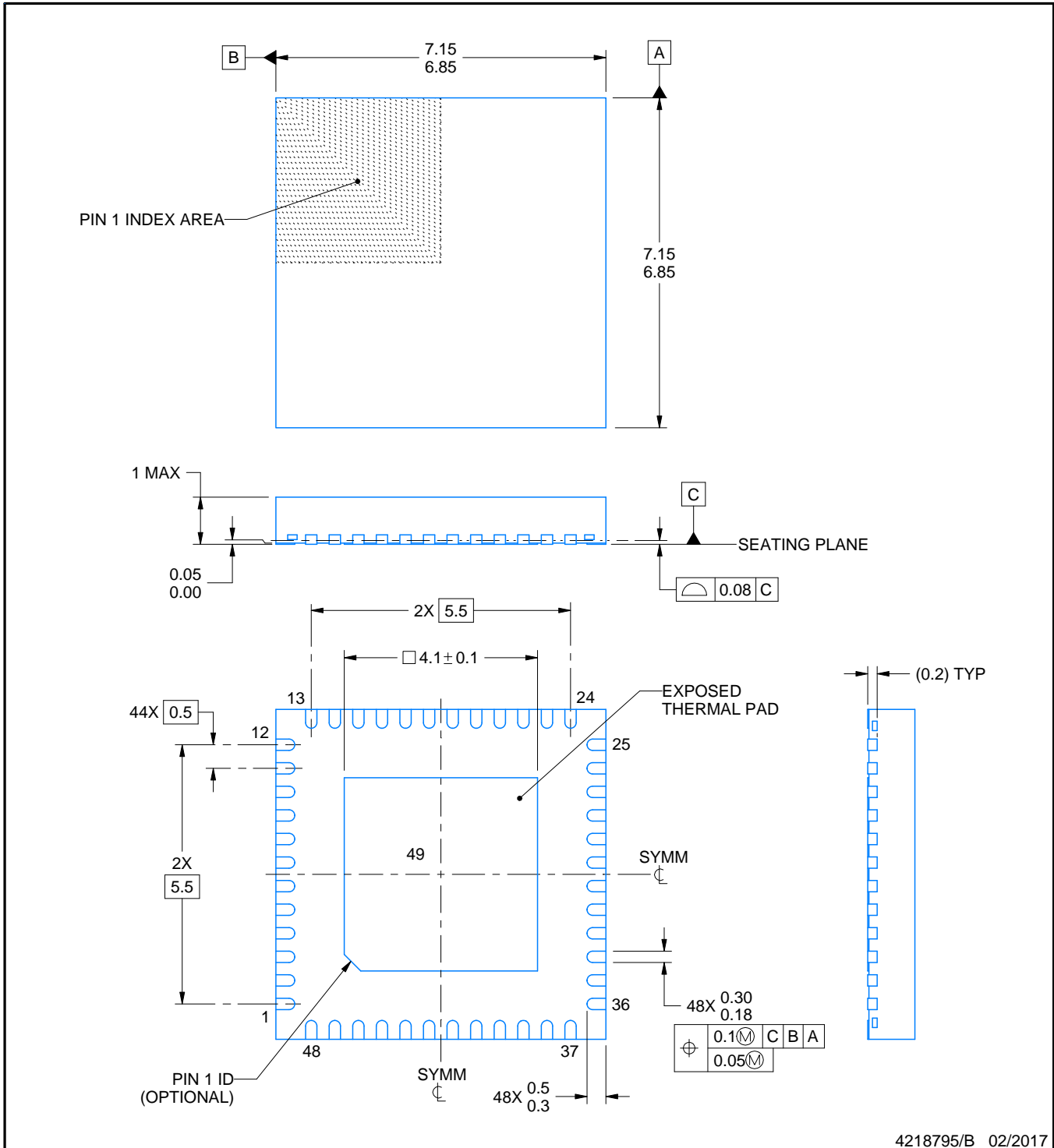

4218795/B 02/2017

NOTES:

1. All linear dimensions are in millimeters. Any dimensions in parenthesis are for reference only. Dimensioning and tolerancing per ASME Y14.5M.
2. This drawing is subject to change without notice.
3. The package thermal pad must be soldered to the printed circuit board for thermal and mechanical performance.

# EXAMPLE BOARD LAYOUT

**RGZ0048B**

**VQFN - 1 mm max height**

PLASTIC QUAD FLATPACK - NO LEAD

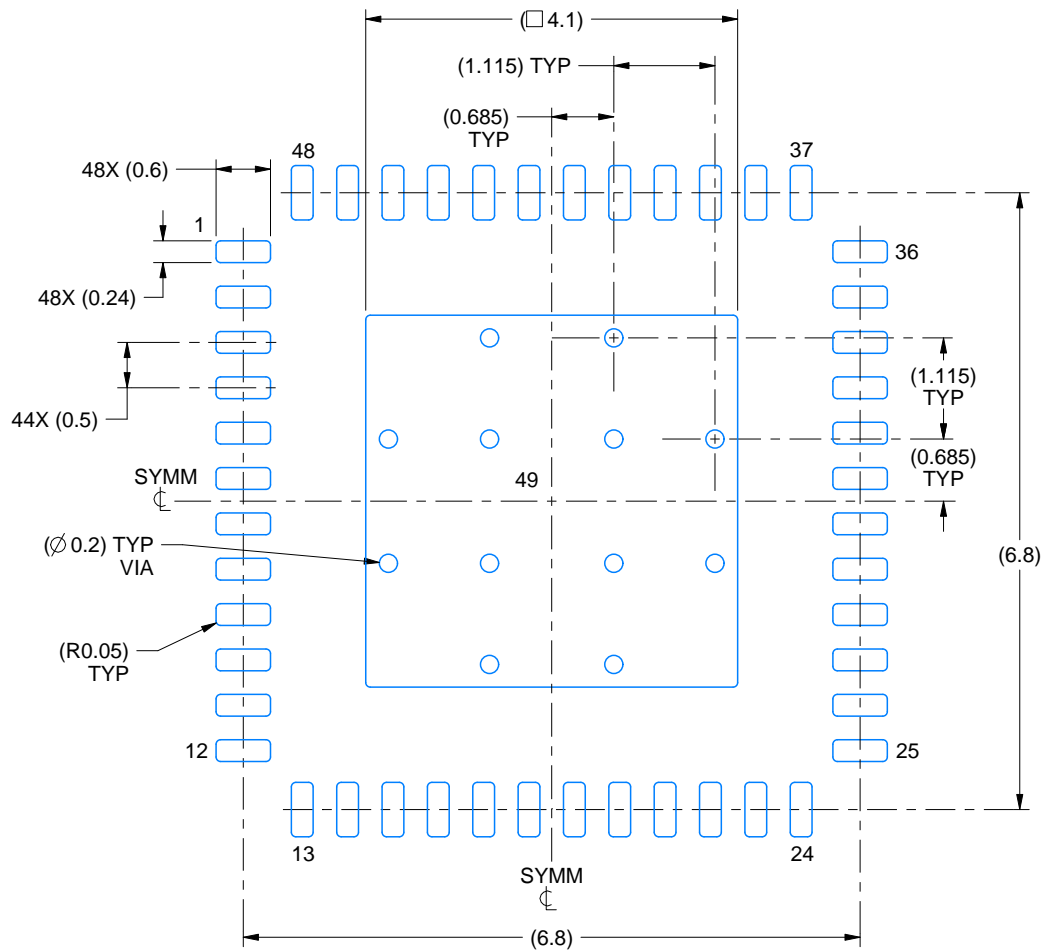

**LAND PATTERN EXAMPLE**  
EXPOSED METAL SHOWN  
SCALE:12X

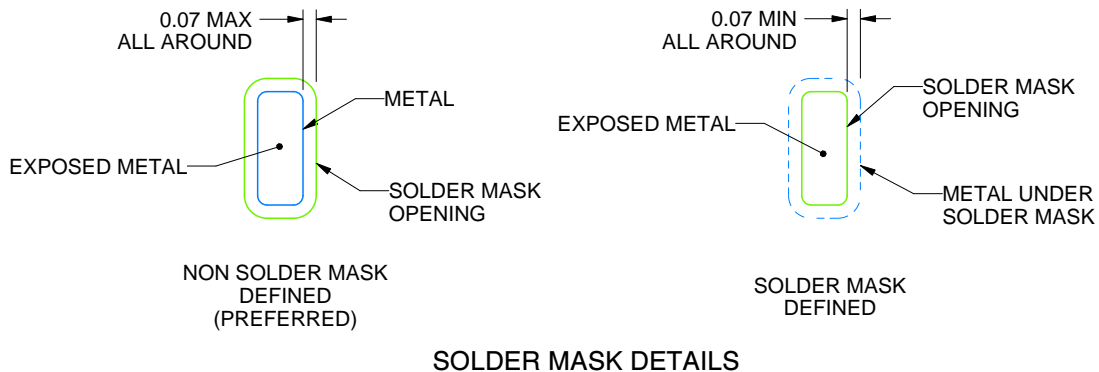

**SOLDER MASK DETAILS**

4218795/B 02/2017

NOTES: (continued)

4. This package is designed to be soldered to a thermal pad on the board. For more information, see Texas Instruments literature number SLUA271 ([www.ti.com/lit/slua271](http://www.ti.com/lit/slua271)).
5. Vias are optional depending on application, refer to device data sheet. If any vias are implemented, refer to their locations shown on this view. It is recommended that vias under paste be filled, plugged or tented.



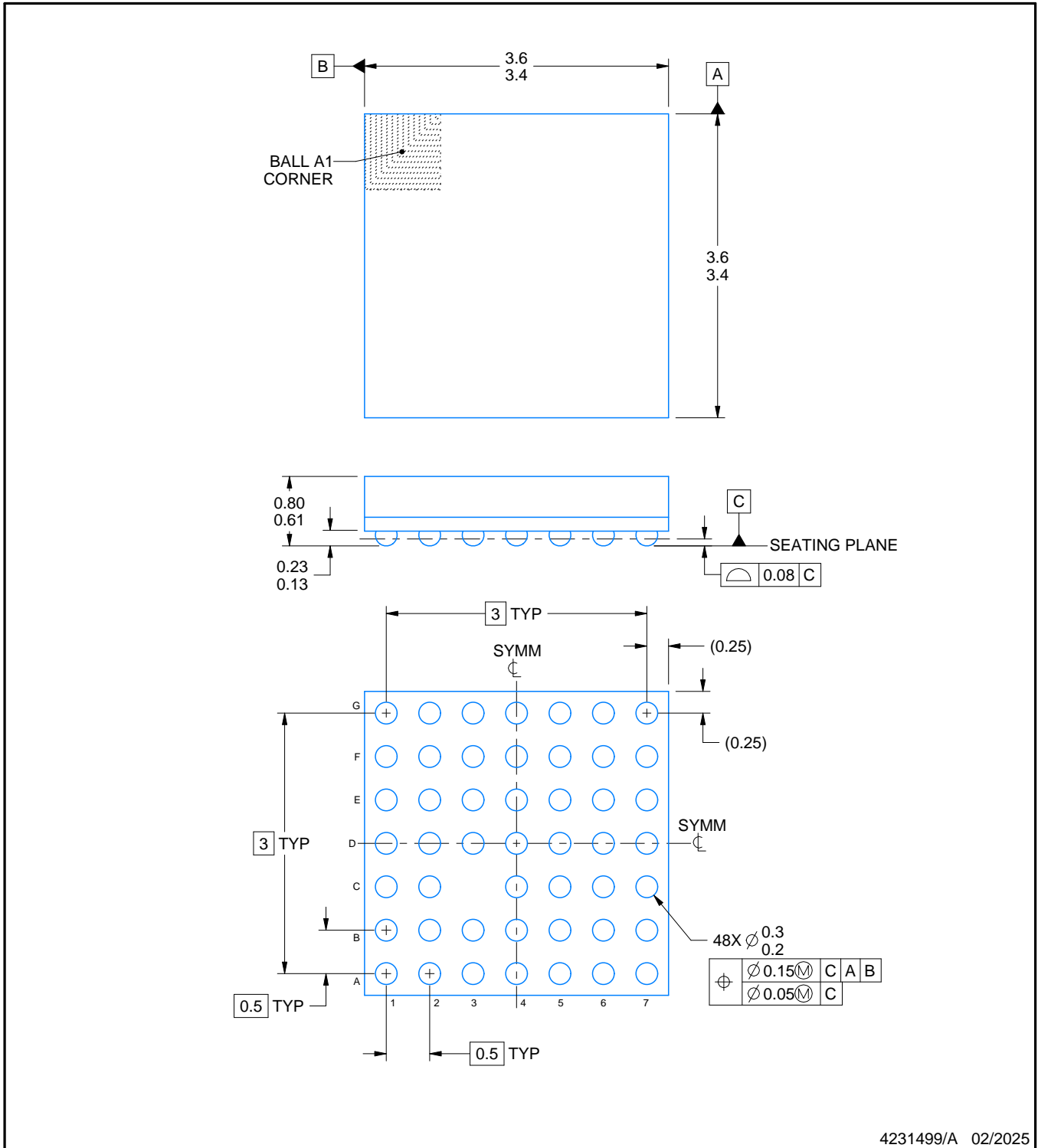
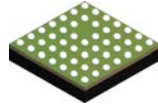

NOTES:

1. All linear dimensions are in millimeters. Any dimensions in parenthesis are for reference only. Dimensioning and tolerancing per ASME Y14.5M.
2. This drawing is subject to change without notice.

# EXAMPLE BOARD LAYOUT

ZCM0048A

NFBGA - 0.8 mm max height

PLASTIC BALL GRID ARRAY

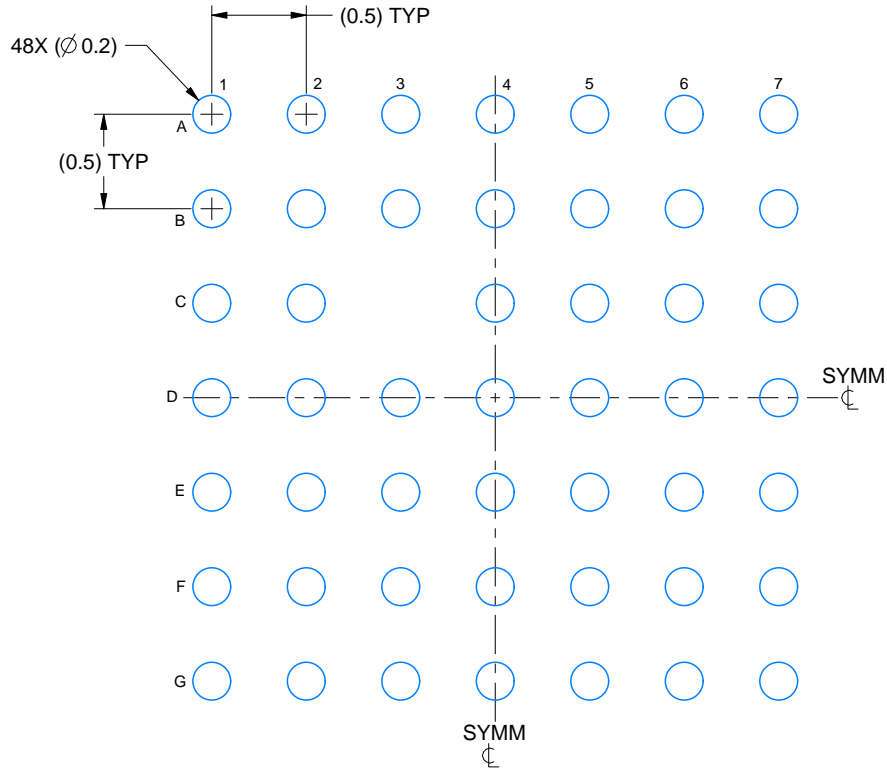

## LAND PATTERN EXAMPLE

EXPOSED METAL SHOWN  
SCALE: 25X

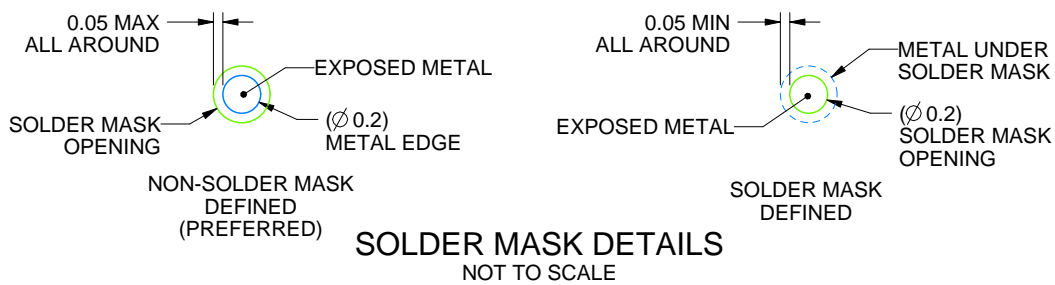

4231499/A 02/2025

NOTES: (continued)

- Final dimensions may vary due to manufacturing tolerance considerations and also routing constraints. For information, see Texas Instruments literature number SPRAA99 ([www.ti.com/lit/spraa99](http://www.ti.com/lit/spraa99)).

# EXAMPLE STENCIL DESIGN

ZCM0048A

NFBGA - 0.8 mm max height

PLASTIC BALL GRID ARRAY

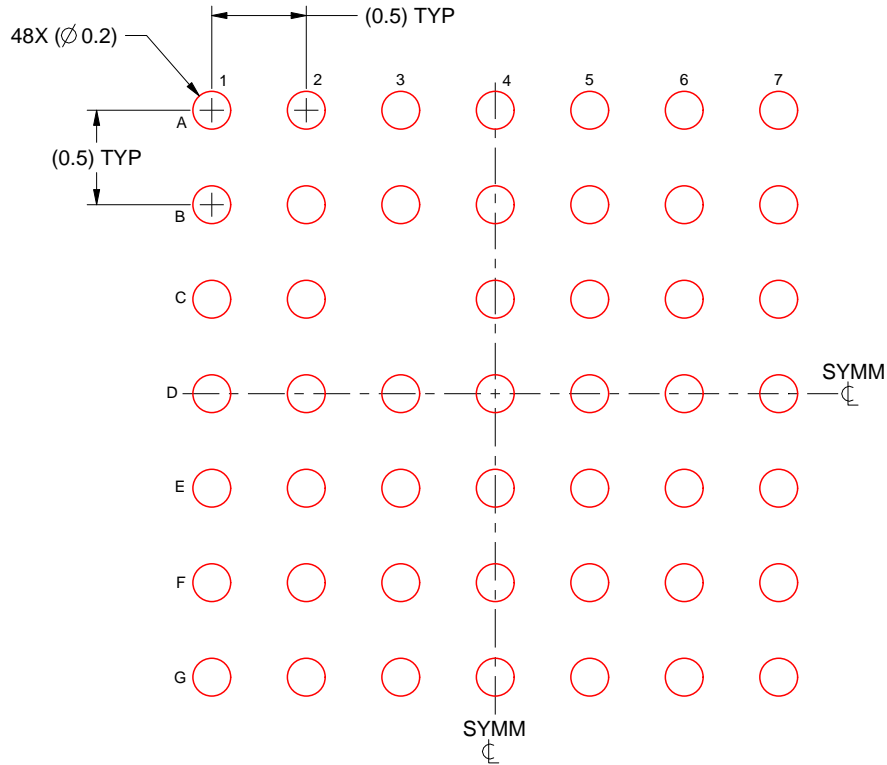

**SOLDER PASTE EXAMPLE**  
BASED ON 0.100 mm THICK STENCIL  
SCALE: 25X

4231499/A 02/2025

NOTES: (continued)

4. Laser cutting apertures with trapezoidal walls and rounded corners may offer better paste release.

## GENERIC PACKAGE VIEW

**RUK 20**

**WQFN - 0.8 mm max height**

3 x 3, 0.4 mm pitch

PLASTIC QUAD FLATPACK - NO LEAD

This image is a representation of the package family, actual package may vary.  
Refer to the product data sheet for package details.

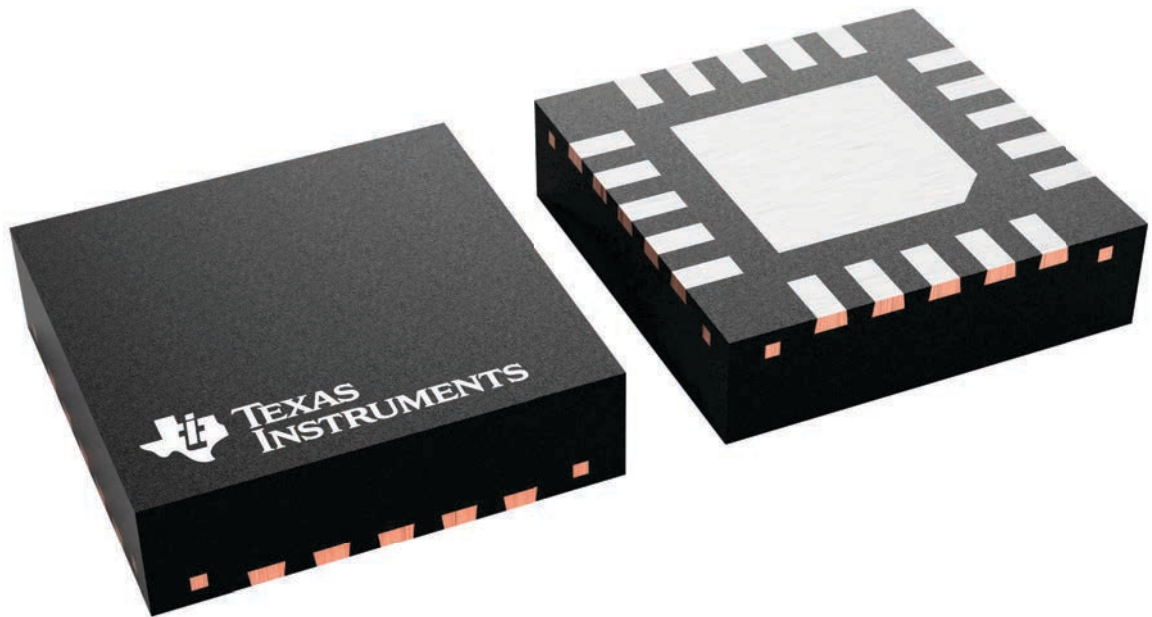

4229651/A

# RUK0020B

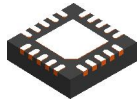

# PACKAGE OUTLINE

## WQFN - 0.8 mm max height

PLASTIC QUAD FLATPACK - NO LEAD

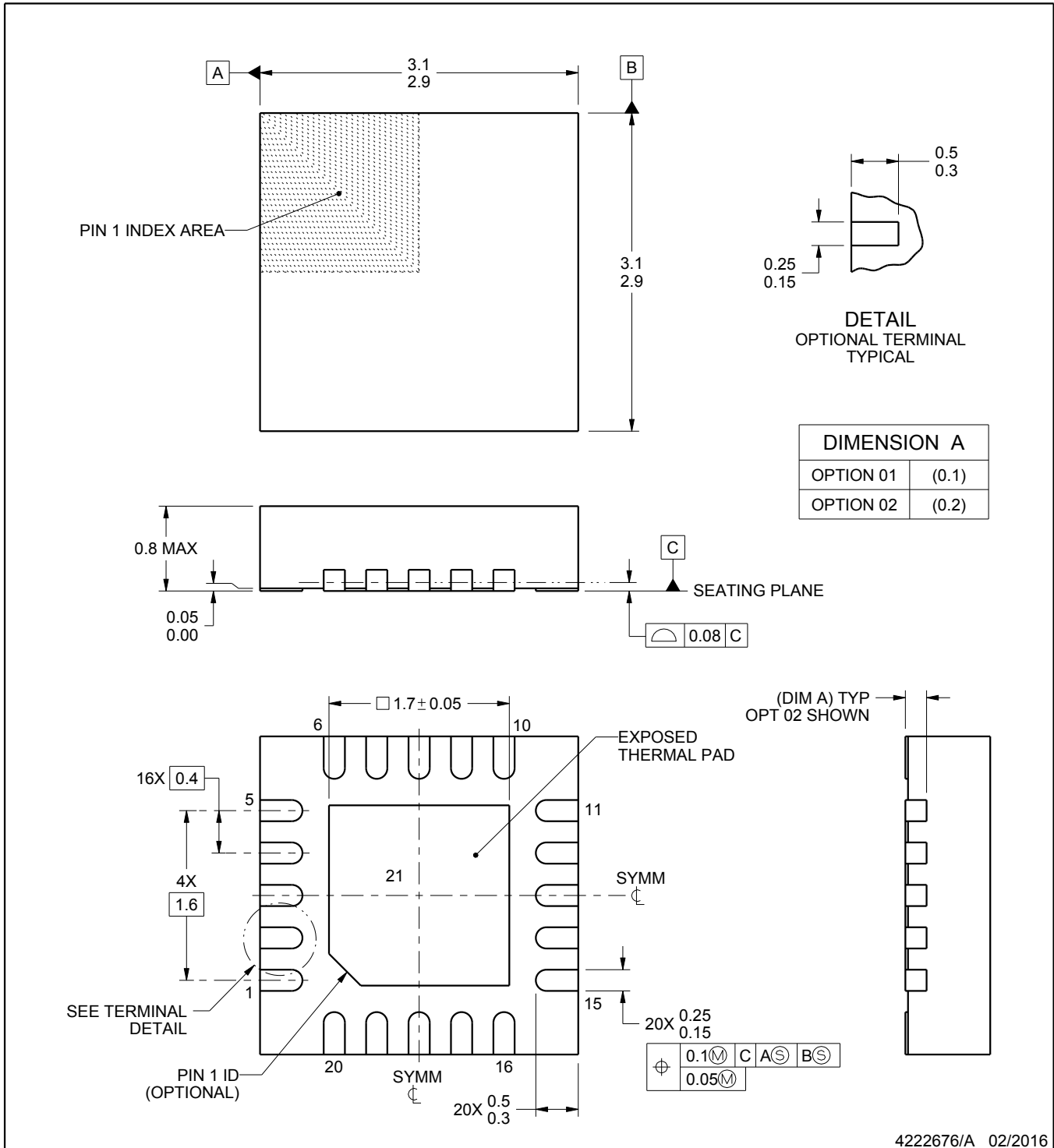

4222676/A 02/2016

**NOTES:**

1. All linear dimensions are in millimeters. Any dimensions in parenthesis are for reference only. Dimensioning and tolerancing per ASME Y14.5M.
2. This drawing is subject to change without notice.
3. The package thermal pad must be soldered to the printed circuit board for thermal and mechanical performance.



# EXAMPLE STENCIL DESIGN

RUK0020B

WQFN - 0.8 mm max height

PLASTIC QUAD FLATPACK - NO LEAD

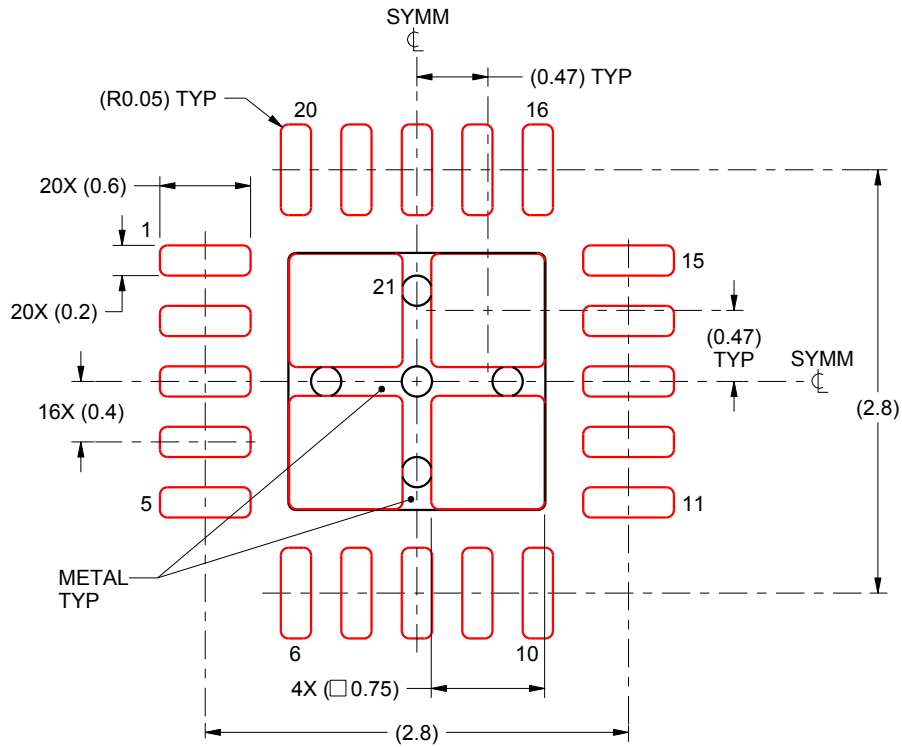

## SOLDER PASTE EXAMPLE BASED ON 0.1 mm THICK STENCIL

EXPOSED PAD 21:  
78% PRINTED SOLDER COVERAGE BY AREA UNDER PACKAGE  
SCALE:20X

4222676/A 02/2016

NOTES: (continued)

6. Laser cutting apertures with trapezoidal walls and rounded corners may offer better paste release. IPC-7525 may have alternate design recommendations.

PT0048A

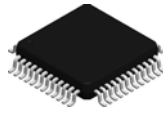

# PACKAGE OUTLINE

LQFP - 1.6 mm max height

LOW PROFILE QUAD FLATPACK

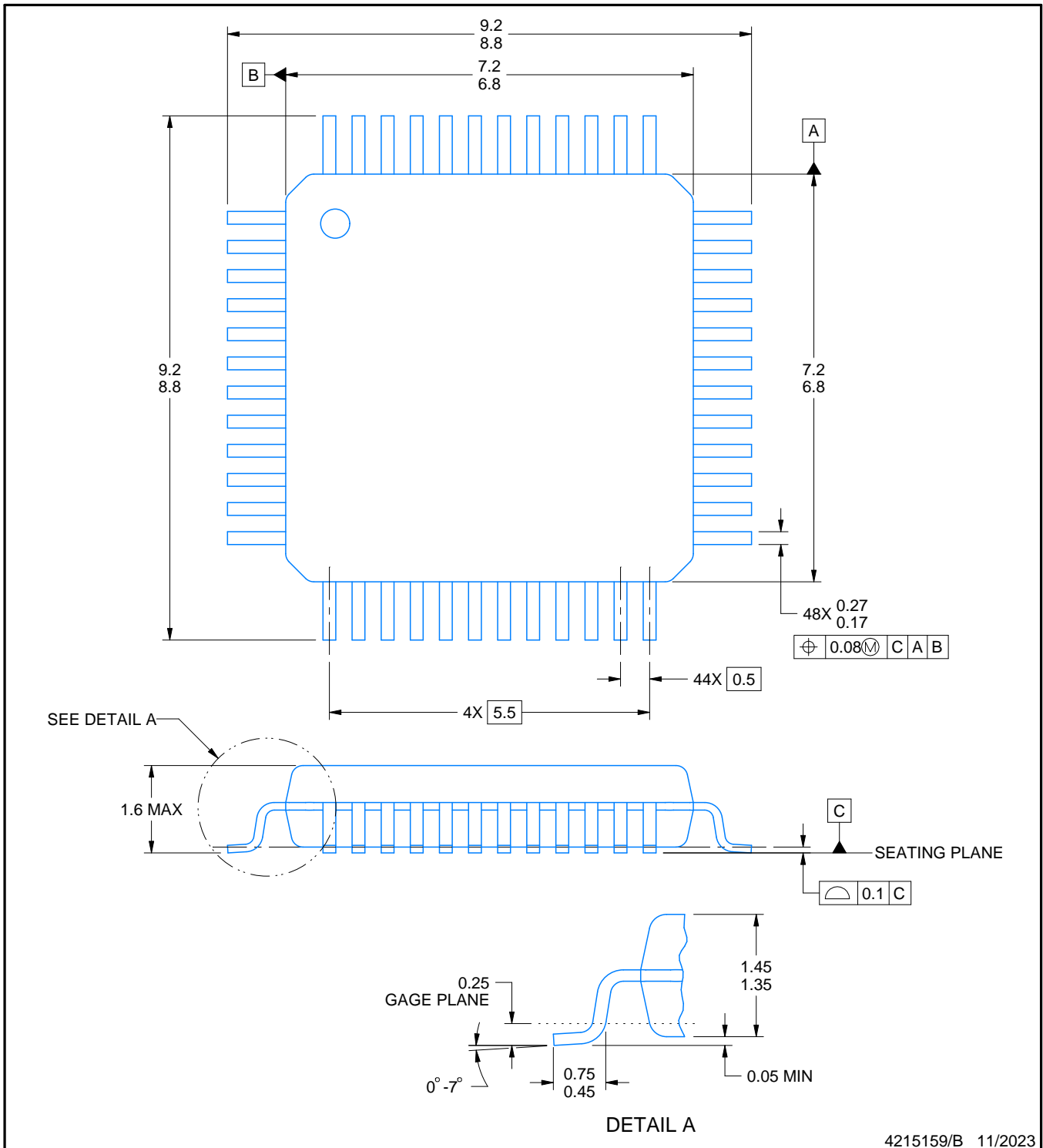

NOTES:

1. All linear dimensions are in millimeters. Any dimensions in parenthesis are for reference only. Dimensioning and tolerancing per ASME Y14.5M.
2. This drawing is subject to change without notice.
3. Reference JEDEC registration MS-026.
4. This may also be a thermally enhanced plastic package with leads connected to the die pads.

# EXAMPLE BOARD LAYOUT

PT0048A

LQFP - 1.6 mm max height

LOW PROFILE QUAD FLATPACK

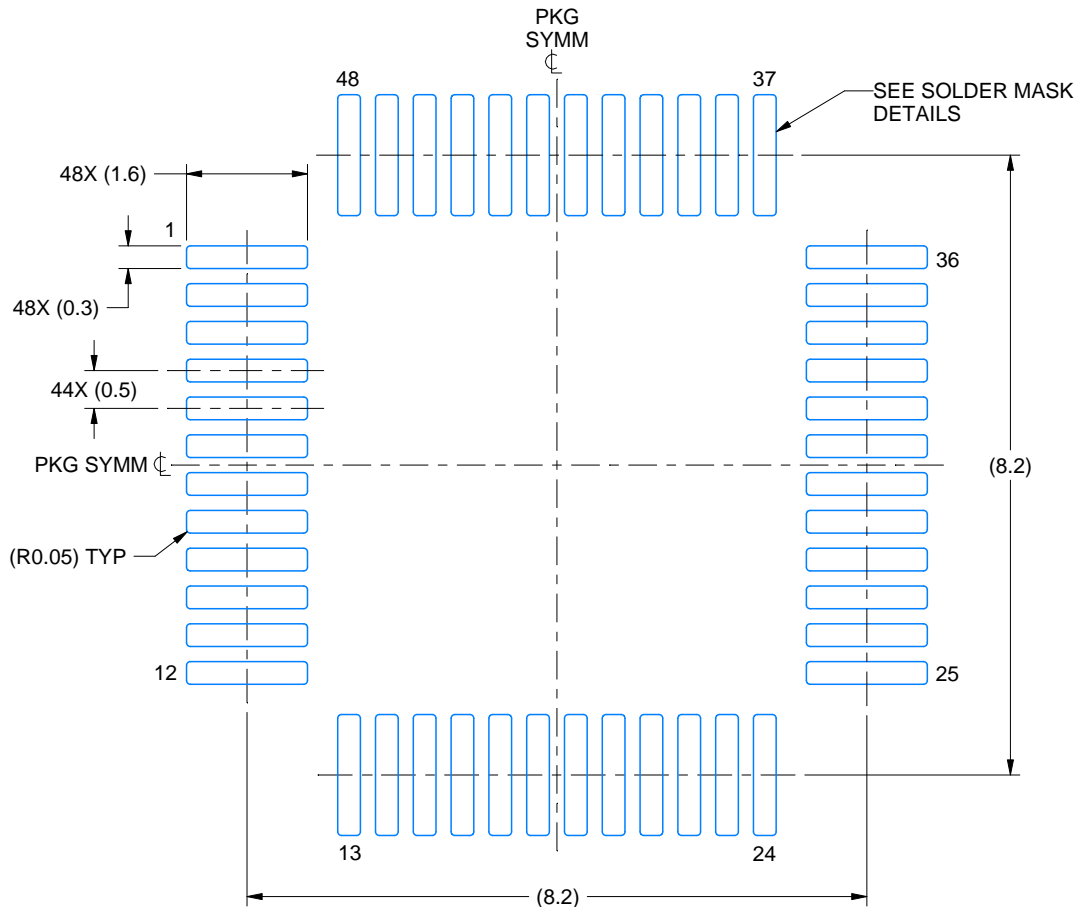

LAND PATTERN EXAMPLE  
EXPOSED METAL SHOWN  
SCALE 10.000

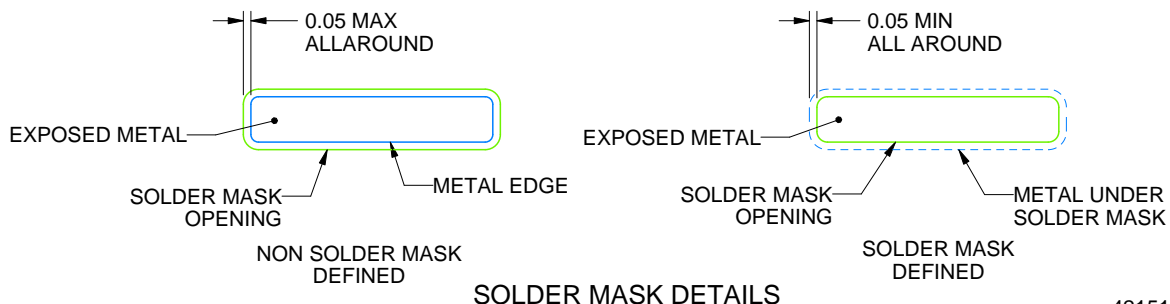

SOLDER MASK DETAILS

4215159/B 11/2023

NOTES: (continued)

- 5. Publication IPC-7351 may have alternate designs.
- 6. Solder mask tolerances between and around signal pads can vary based on board fabrication site.

# EXAMPLE STENCIL DESIGN

PT0048A

LQFP - 1.6 mm max height

LOW PROFILE QUAD FLATPACK

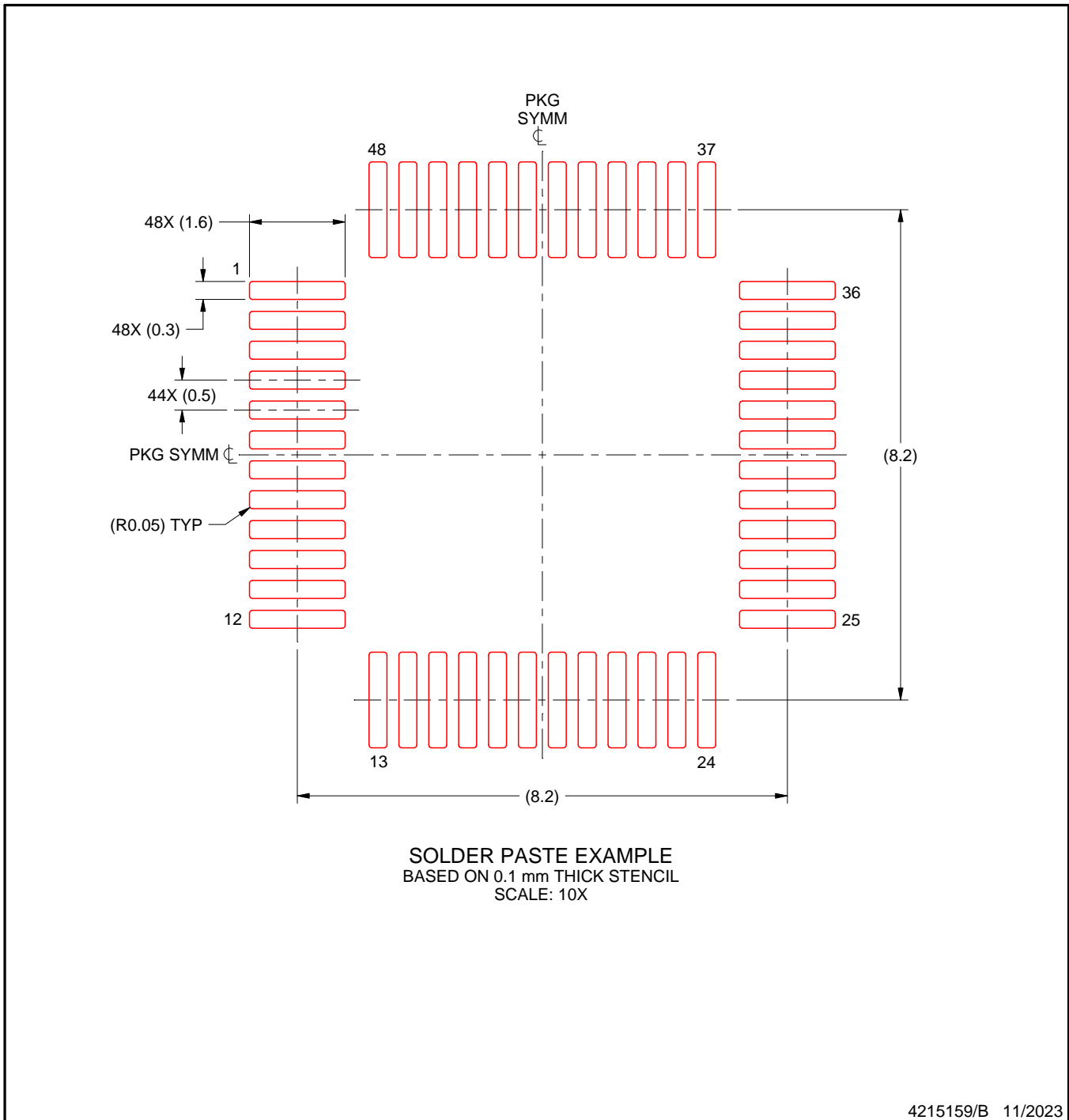

NOTES: (continued)

7. Laser cutting apertures with trapezoidal walls and rounded corners may offer better paste release. IPC-7525 may have alternate design recommendations.
8. Board assembly site may have different recommendations for stencil design.

# DGS0028A



# PACKAGE OUTLINE

VSSOP - 1.1 mm max height

SMALL OUTLINE PACKAGE

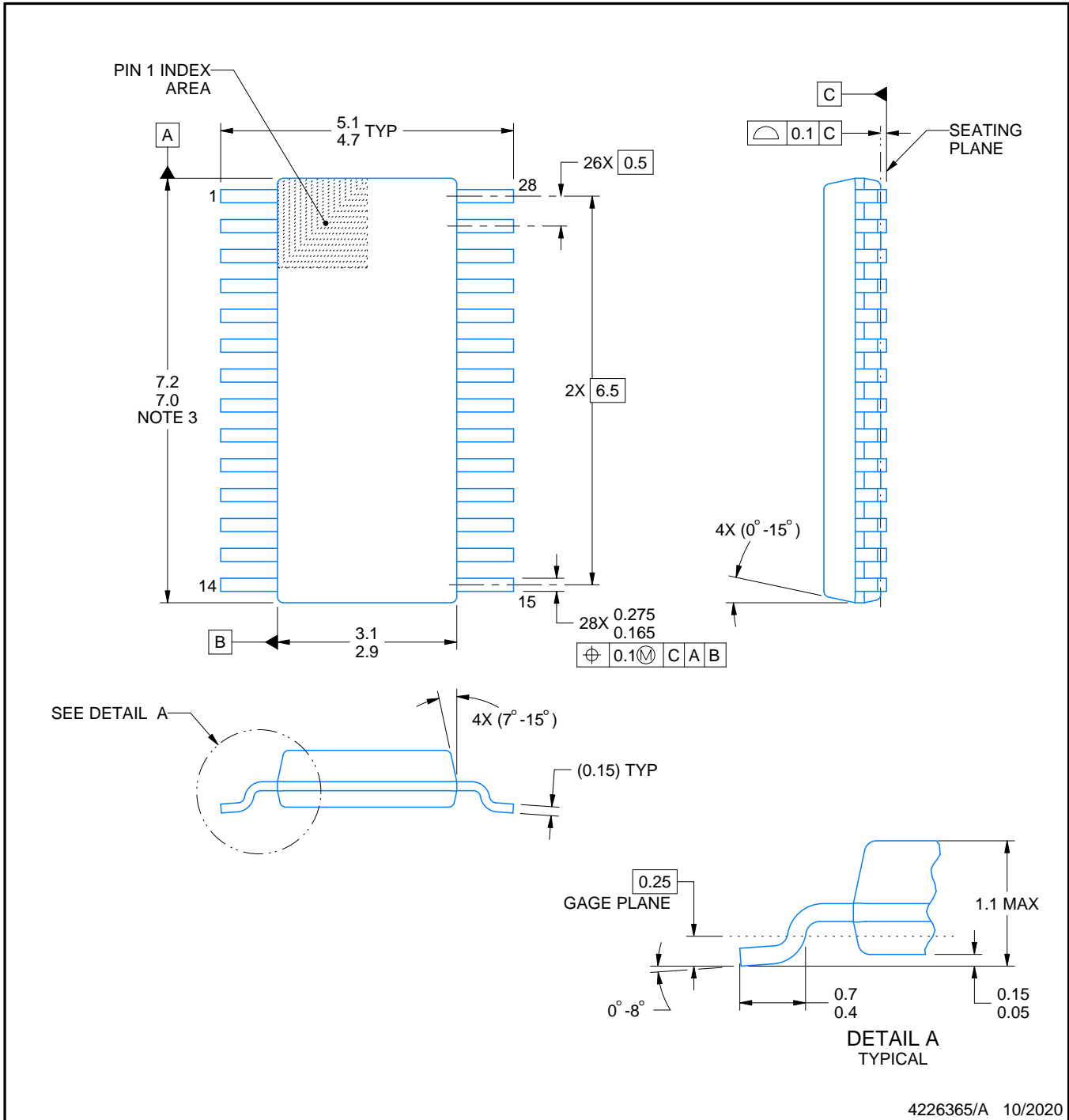

4226365/A 10/2020

**NOTES:**

PowerPAD is a trademark of Texas Instruments.

1. All linear dimensions are in millimeters. Any dimensions in parenthesis are for reference only. Dimensioning and tolerancing per ASME Y14.5M.
2. This drawing is subject to change without notice.
3. This dimension does not include mold flash, protrusions, or gate burrs. Mold flash, protrusions, or gate burrs shall not exceed 0.15 mm per side.
4. No JEDEC registration as of September 2020.
5. Features may differ or may not be present.

# EXAMPLE BOARD LAYOUT

DGS0028A

VSSOP - 1.1 mm max height

SMALL OUTLINE PACKAGE

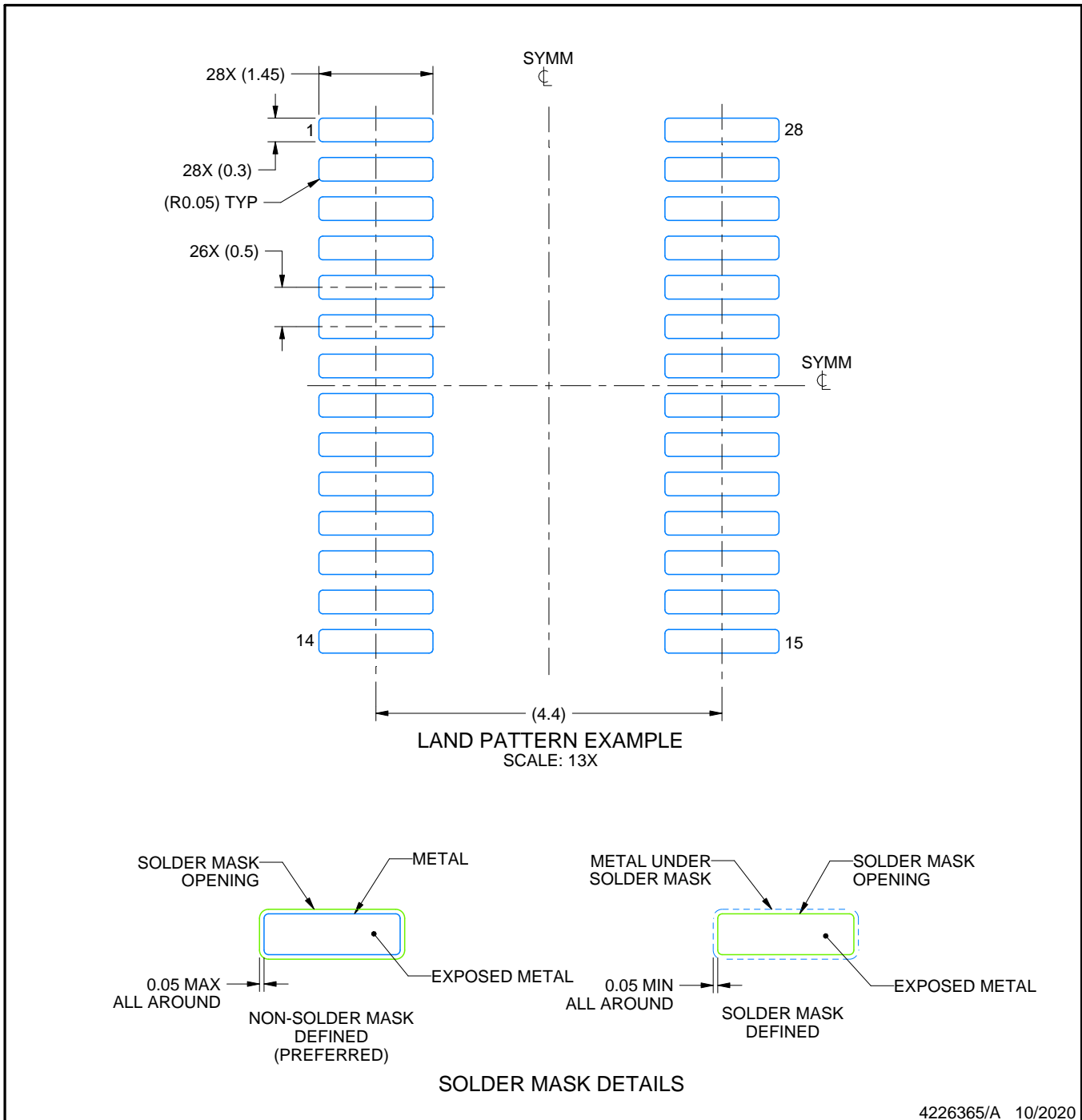

4226365/A 10/2020

NOTES: (continued)

6. Publication IPC-7351 may have alternate designs.
7. Solder mask tolerances between and around signal pads can vary based on board fabrication site.
8. This package is designed to be soldered to a thermal pad on the board. For more information, see Texas Instruments literature numbers SLMA002 ([www.ti.com/lit/slma002](http://www.ti.com/lit/slma002)) and SLMA004 ([www.ti.com/lit/slma004](http://www.ti.com/lit/slma004)).
9. Size of metal pad may vary due to creepage requirement.
10. Vias are optional depending on application, refer to device data sheet. It is recommended that vias under paste be filled, plugged or tented.

# EXAMPLE STENCIL DESIGN

DGS0028A

VSSOP - 1.1 mm max height

SMALL OUTLINE PACKAGE

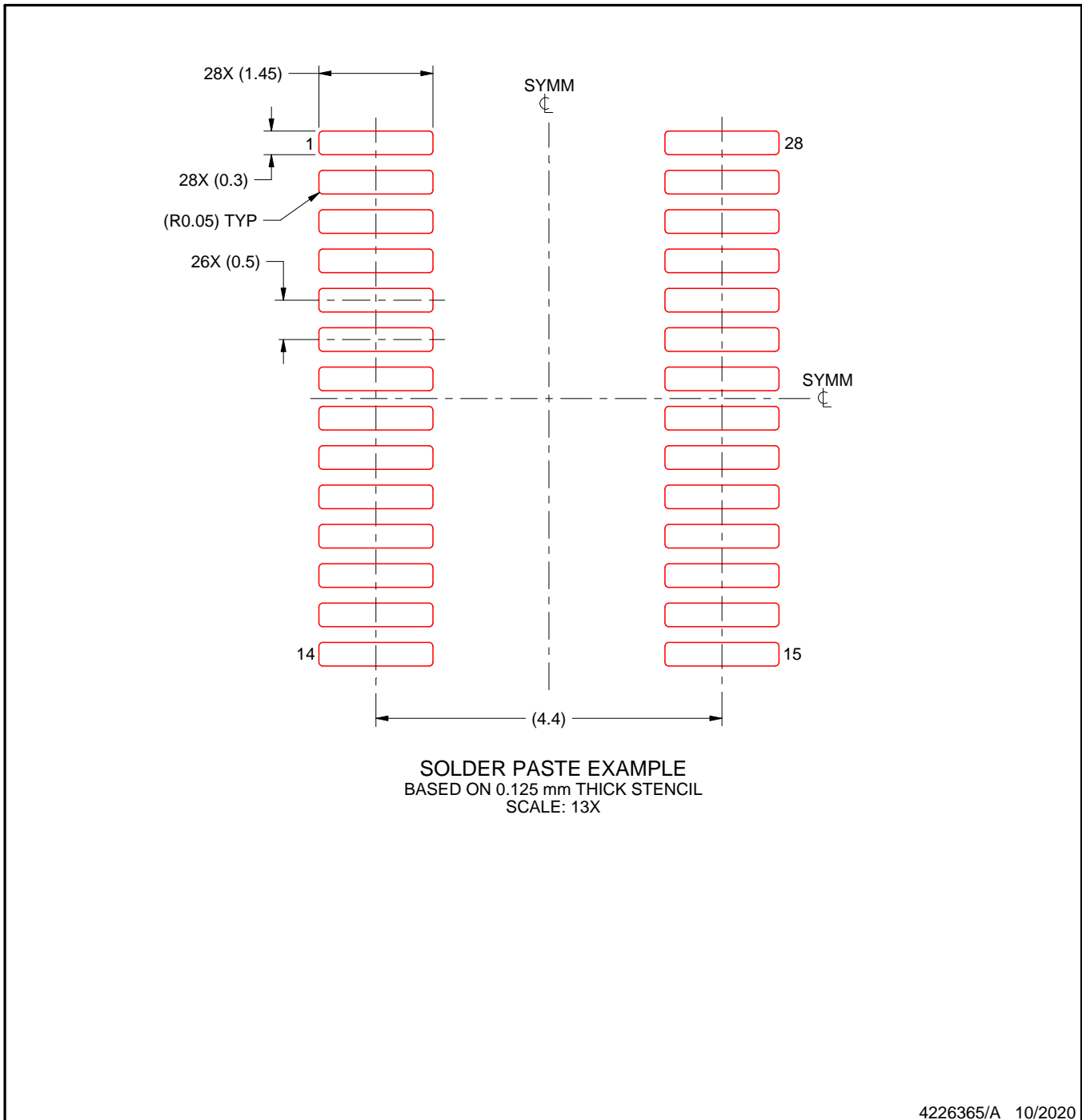

NOTES: (continued)

11. Laser cutting apertures with trapezoidal walls and rounded corners may offer better paste release. IPC-7525 may have alternate design recommendations.
12. Board assembly site may have different recommendations for stencil design.

## IMPORTANT NOTICE AND DISCLAIMER

TI PROVIDES TECHNICAL AND RELIABILITY DATA (INCLUDING DATASHEETS), DESIGN RESOURCES (INCLUDING REFERENCE DESIGNS), APPLICATION OR OTHER DESIGN ADVICE, WEB TOOLS, SAFETY INFORMATION, AND OTHER RESOURCES "AS IS" AND WITH ALL FAULTS, AND DISCLAIMS ALL WARRANTIES, EXPRESS AND IMPLIED, INCLUDING WITHOUT LIMITATION ANY IMPLIED WARRANTIES OF MERCHANTABILITY, FITNESS FOR A PARTICULAR PURPOSE OR NON-INFRINGEMENT OF THIRD PARTY INTELLECTUAL PROPERTY RIGHTS.

These resources are intended for skilled developers designing with TI products. You are solely responsible for (1) selecting the appropriate TI products for your application, (2) designing, validating and testing your application, and (3) ensuring your application meets applicable standards, and any other safety, security, regulatory or other requirements.

These resources are subject to change without notice. TI grants you permission to use these resources only for development of an application that uses the TI products described in the resource. Other reproduction and display of these resources is prohibited. No license is granted to any other TI intellectual property right or to any third party intellectual property right. TI disclaims responsibility for, and you fully indemnify TI and its representatives against any claims, damages, costs, losses, and liabilities arising out of your use of these resources.

TI's products are provided subject to [TI's Terms of Sale](#), [TI's General Quality Guidelines](#), or other applicable terms available either on [ti.com](#) or provided in conjunction with such TI products. TI's provision of these resources does not expand or otherwise alter TI's applicable warranties or warranty disclaimers for TI products. Unless TI explicitly designates a product as custom or customer-specified, TI products are standard, catalog, general purpose devices.

TI objects to and rejects any additional or different terms you may propose.

Copyright © 2026, Texas Instruments Incorporated

Last updated 10/2025