

# LM4041-N LM4041-N-Q1 Precision Micro Power Shunt Voltage Reference

## 1 Features

Updated the numbering format for tables, figures, and cross-references throughout the document

- Qualified for automotive applications
- AEC-Q100 qualified with the following results:
  - Device temperature Grade 1:  $-40^{\circ}\text{C}$  to  $+125^{\circ}\text{C}$  ambient temperature range
  - Device temperature Grade 3:  $-40^{\circ}\text{C}$  to  $+85^{\circ}\text{C}$  ambient temperature range (for SOT-23 only)
- Available in standard, AEC-Q100 Grade 1 (extended temperature range), and Grade 3 (industrial temperature range) qualified versions (SOT-23 only)
- Small packages: SOT-23, TO-92, and SC70
- No output capacitor required
- Tolerates capacitive loads
- Reverse breakdown voltage options of 1.225V and adjustable
- Output voltage tolerance (A grade,  $25^{\circ}\text{C}$ ) =  $\pm 0.1\%$  (maximum)
- Low output noise (10Hz to 10kHz) =  $20\mu\text{V}_{\text{RMS}}$
- Wide operating current range of  $60\mu\text{A}$  to 12mA
- Industrial temperature range (LM4041A/B-N LM4041-N-Q1A/Q1B) of  $-40^{\circ}\text{C}$  to  $+85^{\circ}\text{C}$
- Extended temperature range (LM4041C/D/E-N LM4041-N-Q1C/Q1D/Q1E) of  $-40^{\circ}\text{C}$  to  $+125^{\circ}\text{C}$
- Low temperature coefficient of 100ppm/ $^{\circ}\text{C}$  (maximum)

## 2 Applications

- [Battery-Powered Equipment](#)
- [Data-Acquisition Systems](#)
- [Instrumentation and Test Equipment](#)
- [Process Control](#)
- [Energy Management/Metering](#)
- [Automotive Electronics](#)
- [Precision Audio](#)

## 3 Description

Excellent for space-critical applications, the LM4041-N LM4041-N-Q1 precision voltage reference is available in the sub-miniature SC70 and SOT-23 surface-mount packages. The advanced design of the LM4041-N LM4041-N-Q1 eliminates the need for an external stabilizing capacitor while providing stability with any capacitive load, thus making the LM4041-N LM4041-N-Q1 easy to use. Further reducing design effort is the availability of a fixed (1.225V) and adjustable reverse breakdown voltage. The minimum operating current is  $60\mu\text{A}$  for the LM4041-N LM4041-N-Q1 1.2 and the LM4041-N LM4041-N-Q1 ADJ. Both versions have a maximum operating current of 12mA.

The LM4041-N LM4041-N-Q1 uses fuse and Zener-zap reverse breakdown or reference voltage trim during wafer sort to make sure that the prime parts have an accuracy of better than  $\pm 0.1\%$  (A grade) at  $25^{\circ}\text{C}$ . Band gap reference temperature drift curvature correction and low dynamic impedance provide stable reverse breakdown voltage accuracy over a wide range of operating temperatures and currents.

### Device Information

PART NUMBER	PACKAGE (1)	BODY SIZE (NOM) (2)
LM4041-N	SC70 (5)	1.25mm × 2.00mm
	SOT-23 (3)	1.30mm × 2.92mm
	TO-92 (3)	4.30mm × 4.30mm
LM4041-N-Q1	SOT-23 (3)	1.30mm × 2.92mm

- (1) For all available packages, see the orderable addendum at the end of the data sheet.
- (2) The package size (length × width) is a nominal value and includes pins, where applicable.

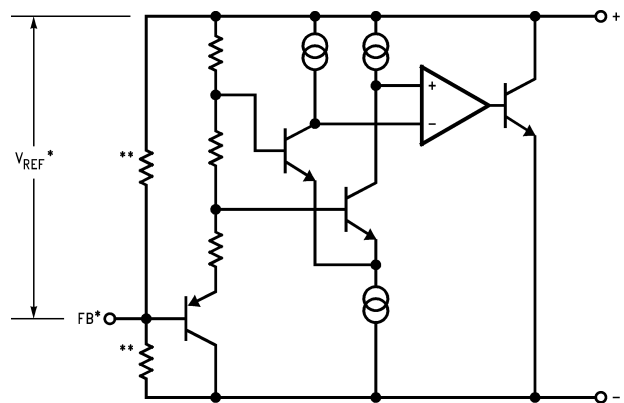

**Block Diagram**



## Table of Contents

<b>1 Features</b> .....	1	5.10 Typical Characteristics.....	16
<b>2 Applications</b> .....	1	<b>6 Parameter Measurement Information</b> .....	19
<b>3 Description</b> .....	1	<b>7 Detailed Description</b> .....	20
<b>4 Pin Configuration and Functions</b> .....	3	7.1 Overview.....	20
Pin Functions.....	3	7.2 Functional Block Diagram.....	20
Pin Functions: ADJ Pinouts.....	4	7.3 Feature Description.....	20
<b>5 Specifications</b> .....	5	7.4 Device Functional Modes.....	20
5.1 Absolute Maximum Ratings.....	5	<b>8 Application and Implementation</b> .....	21
5.2 ESD Ratings.....	5	8.1 Application Information.....	21
5.3 Recommended Operating Conditions.....	5	8.2 Typical Applications.....	22
5.4 Thermal Information.....	6	8.3 Power Supply Recommendations.....	30
5.5 LM4041-N LM4041-N-Q1 1.2 Electrical Characteristics (Industrial Temperature Range).....	7	8.4 Layout.....	30
5.6 LM4041-N LM4041-N-Q1 1.2 Electrical Characteristics (Industrial Temperature Range).....	8	<b>9 Device and Documentation Support</b> .....	31
5.7 LM4041-N LM4041-N-Q1 1.2 Electrical Characteristics (Extended Temperature Range).....	10	9.1 Receiving Notification of Documentation Updates....	31
5.8 LM4041-N LM4041-N-Q1 ADJ (Adjustable) Electrical Characteristics (Industrial Temperature Range).....	13	9.2 Support Resources.....	31
5.9 LM4041-N LM4041-N-Q1 ADJ (Adjustable) Electrical Characteristics (Extended Temperature Range).....	15	9.3 Trademarks.....	31
		9.4 Electrostatic Discharge Caution.....	31
		9.5 Glossary.....	31
		<b>10 Revision History</b> .....	31
		<b>11 Mechanical, Packaging, and Orderable Information</b> .....	32

## 4 Pin Configuration and Functions

### Pin Functions

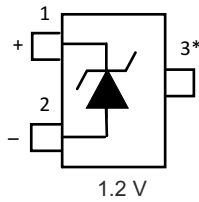

**Figure 4-1. DBZ Package  
3-Pin SOT-23  
Top View**

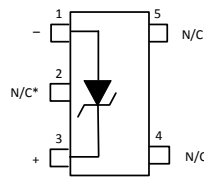

**Figure 4-2. DCK Package  
5-Pin SC70  
Top View**

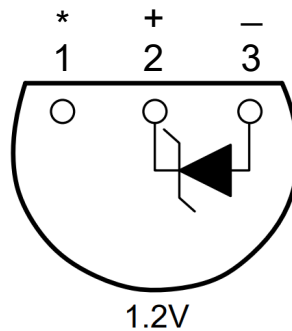

**Figure 4-3. LP Package  
3-Pin TO-92  
Bottom View**

### Pin Functions

NAME	PIN			I/O	DESCRIPTION
	SOT-23	SC70	TO-92		
Anode	2	1	3	O	Anode pin, normally grounded
Cathode	1	3	2	I/O	Shunt current and output voltage
FB	—	—	—	I	Feedback pin for adjustable output voltage
NC*	3	2	1	—	**Must float or connect to anode <sup>(1)</sup>
NC	—	4, 5	—	—	No connect

(1) In applications with high electromagnetic interference (for example, when placed near transformers or other electromagnetic sources) or significant high-frequency switching noise, TI recommends to connect this pin to the anode.

**Pin Functions: ADJ Pinouts**

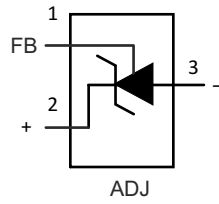

**Figure 4-4. DBZ Package  
3-Pin SOT-23  
Top View**

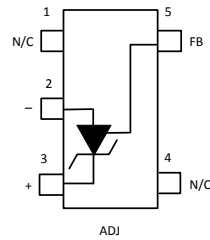

**Figure 4-5. DCK Package  
5-Pin SC70  
Top View**

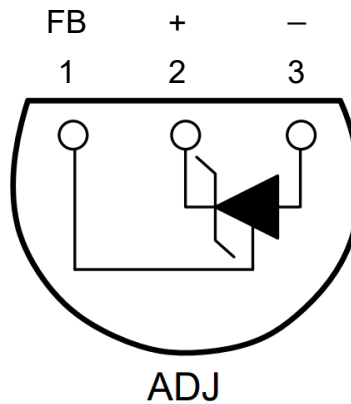

**Figure 4-6. LP Package  
3-Pin TO-92  
Bottom View**

NAME	PIN			I/O	DESCRIPTION
	SOT-23	SC70	TO-92		
Anode	3	2	3	O	Anode pin, normally grounded
Cathode	2	3	2	I/O	Shunt current and output voltage
FB	1	5	1	I	Feedback pin for adjustable output voltage
NC**	—	—	—	—	**Must float or connect to anode
NC	—	1, 4	—	—	No connect

## 5 Specifications

### 5.1 Absolute Maximum Ratings

over operating free-air temperature range (unless otherwise noted)<sup>(1) (2)</sup>

		MIN	MAX	UNIT
Reverse current			20	mA
Forward current			10	mA
Maximum output voltage (LM4041-N LM4041-N-Q1 ADJ)			15	V
Power dissipation ( $T_A = 25^\circ\text{C}$ ) <sup>(3)</sup>	DBZ package		306	mW
	LP package		550	
	DCK package		241	
Lead temperature	DBZ packages	Vapor phase (60 seconds)	215	$^\circ\text{C}$
		Infrared (15 seconds)	220	$^\circ\text{C}$
	LP package	Soldering (10 seconds)	260	$^\circ\text{C}$
Storage temperature, $T_{\text{stg}}$		-65	150	$^\circ\text{C}$

- (1) Stresses beyond those listed under *Absolute Maximum Ratings* can cause permanent damage to the device. These are stress ratings only, which do not imply functional operation of the device at these or any other conditions beyond those indicated under *Recommended Operating Conditions*. Exposure to absolute-maximum-rated conditions for extended periods can affect device reliability.
- (2) If Military/Aerospace specified devices are required, please contact the TI Sales Office/ Distributors for availability and specifications.
- (3) The maximum power dissipation must be derated at elevated temperatures and is dictated by  $T_{\text{Jmax}}$  (maximum junction temperature),  $\theta_{\text{JA}}$  (junction to ambient thermal resistance), and  $T_A$  (ambient temperature). The maximum allowable power dissipation at any temperature is  $\text{PD}_{\text{max}} = (T_{\text{Jmax}} - T_A)/R_{\theta\text{JA}}$  or the number given in the *Absolute Maximum Ratings*, whichever is lower. For the LM4041-N,  $T_{\text{Jmax}} = 125^\circ\text{C}$ , and the typical thermal resistance ( $R_{\theta\text{JA}}$ ), when board mounted, is  $326^\circ\text{C/W}$  for the SOT-23 package,  $415^\circ\text{C/W}$  for the SC70 package and  $180^\circ\text{C/W}$  with 0.4-in lead length and  $170^\circ\text{C/W}$  with 0.125-in lead length for the TO-92 package.

### 5.2 ESD Ratings

		VALUE	UNIT
$V_{\text{(ESD)}}$	Electrostatic discharge	Human-body model (HBM), per ANSI/ESDA/JEDEC JS-001 <sup>(1) (2)</sup>	$\pm 2000$
		Charged-device model (CDM), per JEDEC specification JESD22-C101 <sup>(3)</sup>	$\pm 500$

- (1) JEDEC document JEP155 states that 500V HBM allows safe manufacturing with a standard ESD control process.
- (2) The human-body model is a 100pF capacitor discharged through a 1.5k $\Omega$  resistor into each pin. All pins are rated at 2kV for human-body model, but the feedback pin which is rated at 1kV.
- (3) JEDEC document JEP157 states that 250V CDM allows safe manufacturing with a standard ESD control process. Manufacturing with less than 250V CDM is possible with the necessary precautions.

### 5.3 Recommended Operating Conditions

See <sup>(1)</sup>

		MIN	NOM	MAX	UNIT
Temperature		$T_{\text{min}}$	$T_A$	$T_{\text{max}}$	$^\circ\text{C}$
Industrial temperature		-40	$T_A$	85	$^\circ\text{C}$
Extended temperature		-40	$T_A$	125	$^\circ\text{C}$
Reverse current	LM4041-N LM4041-N-Q1 1.2	60		12000	$\mu\text{A}$
	LM4041-N LM4041-N-Q1 ADJ	60		12000	$\mu\text{A}$
Output voltage	LM4041-N LM4041-N-Q1 ADJ	1.24		10	V

- (1) *Absolute Maximum Ratings* indicate limits beyond which damage to the device can occur. *Recommended Operating Conditions* indicate conditions for which the device is functional, but do not ensure specific performance limits. For specifications and test conditions, see the *Electrical Characteristics*. The specifications apply only for the test conditions listed. Some performance characteristics can degrade when the device is not operated under the listed test conditions.

## 5.4 Thermal Information

THERMAL METRIC <sup>(1)</sup>		LM4041-N			UNIT
		SC70	TO-92	SOT-23	
		5 PINS	3 PINS	3 PINS	
$R_{\theta JA}$	Junction-to-ambient thermal resistance	265.3	161.5	291.9	°C/W
$R_{\theta JC(top)}$	Junction-to-case (top) thermal resistance	93.1	84.5	114.3	°C/W
$R_{\theta JB}$	Junction-to-board thermal resistance	46.7	—	62.3	°C/W
$\psi_{JT}$	Junction-to-top characterization parameter	2.2	28.4	7.4	°C/W
$\psi_{JB}$	Junction-to-board characterization parameter	45.9	140.6	61	°C/W
$R_{\theta JC(bot)}$	Junction-to-case (bottom) thermal resistance	—	—	—	°C/W

- (1) For more information about traditional and new thermal metrics, see the [Semiconductor and IC Package Thermal Metrics](#) (SPRA953) application report.

## 5.5 LM4041-N LM4041-N-Q1 1.2 Electrical Characteristics (Industrial Temperature Range)

All limits  $T_A = T_J = 25^\circ\text{C}$  for the LM4041AIM3, LM4041BIM3, LM4041AIZ, LM4041BIZ and LM4041BIM7 LM4041QAIM3 and LM4041QBIM3 devices, unless otherwise specified. The grades A and B designate initial reverse breakdown voltage tolerances of  $\pm 0.1\%$  and  $\pm 0.2\%$ , respectively.

PARAMETER		TEST CONDITIONS		MIN <sup>(1)</sup>	TYP <sup>(2)</sup>	MAX <sup>(1)</sup>	UNIT	
$V_R$	Reverse breakdown voltage	$I_R = 100\mu\text{A}$		1.225			V	
	Reverse breakdown voltage tolerance <sup>(3)</sup>	$I_R = 100\mu\text{A}$	LM4041AIM3 LM4041QAIM3 LM4041AIM3, LM4041AIZ	$\pm 1.2$			mV	
			LM4041BIM3 LM4041QBIM3 LM4041BIZ, LM4041BIM7	$\pm 2.4$				
		$T_A = T_J = T_{\text{MIN}}$ to $T_{\text{MAX}}$	LM4041AIM3 LM4041QAIM3 LM4041AIM3, LM4041AIZ	$\pm 9.2$				
			LM4041BIM3 LM4041QBIM3 LM4041BIZ, LM4041BIM7	$\pm 10.4$				
$I_{\text{RMIN}}$	Minimum operating current	$T_A = T_J = 25^\circ\text{C}$		45		60	$\mu\text{A}$	
		$T_A = T_J = T_{\text{MIN}}$ to $T_{\text{MAX}}$				65		
$\Delta V_R/\Delta T$	Average reverse breakdown voltage temperature Coefficient <sup>(3)</sup>	$I_R = 10\text{mA}$		$\pm 20$			ppm/ $^\circ\text{C}$	
		$I_R = 1\text{mA}$	$T_A = T_J = 25^\circ\text{C}$		$\pm 15$			
			$T_A = T_J = T_{\text{MIN}}$ to $T_{\text{MAX}}$		$\pm 100$			
		$I_R = 100\mu\text{A}$		$\pm 15$				
$\Delta V_R/\Delta I_R$	Reverse breakdown voltage change with operating current change <sup>(4)</sup>	$I_{\text{RMIN}} \leq I_R \leq 1\text{mA}$	$T_A = T_J = 25^\circ\text{C}$	0.7		1.5	mV	
			$T_A = T_J = T_{\text{MIN}}$ to $T_{\text{MAX}}$	2				
		$1\text{mA} \leq I_R \leq 12\text{mA}$	$T_A = T_J = 25^\circ\text{C}$	4		6		
			$T_A = T_J = T_{\text{MIN}}$ to $T_{\text{MAX}}$	8				
$Z_R$	Reverse dynamic impedance	$I_R = 1\text{mA}$ , $f = 120\text{Hz}$ , $I_{\text{AC}} = 0.1 I_R$		0.5		1.5	$\Omega$	
$e_N$	Wide band noise	$I_R = 100\mu\text{A}$ $10\text{Hz} \leq f \leq 10\text{kHz}$		20			$\mu\text{V}_{\text{RMS}}$	
$\Delta V_R$	Reverse breakdown voltage long-term stability	$t = 1000\text{ hrs}$ $T = 25^\circ\text{C} \pm 0.1^\circ\text{C}$ $I_R = 100\mu\text{A}$		120			ppm	
$V_{\text{HYST}}$	Thermal hysteresis <sup>(5)</sup>	$\Delta T = -40^\circ\text{C}$ to $+125^\circ\text{C}$		0.08%				

- (1) Limits are 100% production tested at  $25^\circ\text{C}$ . Limits over temperature are made sure through correlation using Statistical Quality Control (SQC) methods. The limits are used to calculate AOQL.
- (2) Typical values are at  $T_J = 25^\circ\text{C}$  and represent most likely parametric norm.
- (3) The over temperature limit for Reverse Breakdown Voltage Tolerance is defined as the room temperature Reverse Breakdown Voltage Tolerance  $\pm[(\Delta V_R/\Delta T)(\max \Delta T)(V_R)]$ . Where,  $\Delta V_R/\Delta T$  is the  $V_R$  temperature coefficient,  $\max \Delta T$  is the maximum difference in temperature from the reference point of  $25^\circ\text{C}$  to  $T_{\text{MAX}}$  or  $T_{\text{MIN}}$ , and  $V_R$  is the reverse breakdown voltage. The total over-temperature tolerance for the different grades in the industrial temperature range where  $\max \Delta T = 65^\circ\text{C}$  is shown below:  
 A-grade:  $\pm 0.75\% = \pm 0.1\% \pm 100\text{ppm}/^\circ\text{C} \times 65^\circ\text{C}$   
 B-grade:  $\pm 0.85\% = \pm 0.2\% \pm 100\text{ppm}/^\circ\text{C} \times 65^\circ\text{C}$   
 C-grade:  $\pm 1.15\% = \pm 0.5\% \pm 100\text{ppm}/^\circ\text{C} \times 65^\circ\text{C}$   
 D-grade:  $\pm 1.98\% = \pm 1.0\% \pm 150\text{ppm}/^\circ\text{C} \times 65^\circ\text{C}$   
 E-grade:  $\pm 2.98\% = \pm 2.0\% \pm 150\text{ppm}/^\circ\text{C} \times 65^\circ\text{C}$   
 The total over-temperature tolerance for the different grades in the extended temperature range where  $\max \Delta T = 100^\circ\text{C}$  is shown below:  
 B-grade:  $\pm 1.2\% = \pm 0.2\% \pm 100\text{ppm}/^\circ\text{C} \times 100^\circ\text{C}$   
 C-grade:  $\pm 1.5\% = \pm 0.5\% \pm 100\text{ppm}/^\circ\text{C} \times 100^\circ\text{C}$   
 D-grade:  $\pm 2.5\% = \pm 1.0\% \pm 150\text{ppm}/^\circ\text{C} \times 100^\circ\text{C}$   
 E-grade:  $\pm 4.5\% = \pm 2.0\% \pm 150\text{ppm}/^\circ\text{C} \times 100^\circ\text{C}$   
 Therefore, as an example, the A-grade LM4041-N LM4041-N-Q1 1.2 has an over-temperature Reverse Breakdown Voltage tolerance of  $\pm 1.2\text{ V} \times 0.75\% = \pm 9.2\text{mV}$ .
- (4) Load regulation is measured on pulse basis from no load to the specified load current. Output changes due to die temperature change must be taken into account separately.
- (5) Thermal hysteresis is defined as the difference in voltage measured at  $+25^\circ\text{C}$  after cycling to temperature  $-40^\circ\text{C}$  and the  $+25^\circ\text{C}$  measurement after cycling to temperature  $+125^\circ\text{C}$ .

## 5.6 LM4041-N LM4041-N-Q1 1.2 Electrical Characteristics (Industrial Temperature Range)

All limits  $T_A = T_J = 25^\circ\text{C}$ , unless otherwise specified. The grades C, D, and E designate initial reverse breakdown voltage tolerances of  $\pm 0.5\%$ ,  $\pm 1.0\%$ , and  $\pm 2.0\%$ , respectively.

PARAMETER		TEST CONDITIONS		MIN <sup>(1)</sup>	TYP <sup>(2)</sup>	MAX <sup>(1)</sup>	UNIT
$V_R$	Reverse Breakdown Voltage	$I_R = 100\mu\text{A}$			1.225		V
	Reverse breakdown voltage tolerance <sup>(3)</sup>	$I_R = 100\mu\text{A}$	$T_A = T_J = 25^\circ\text{C}$	LM4041CIM3 LM4041QCIM3 LM4041CIZ, LM4041CIM7		$\pm 6$	mV
				LM4041DIM3 LM4041QDIM3 LM4041DIZ, LM4041DIM7		$\pm 12$	
				LM4041EIM3 LM4041QEIM3 LM4041EIZ, LM4041EIM7		$\pm 25$	
		$T_A = T_J = T_{\text{MIN}}$ to $T_{\text{MAX}}$	LM4041CIM3 LM4041QCIM3 LM4041CIZ, LM4041CIM7		$\pm 14$		
			LM4041DIM3 LM4041QDIM3 LM4041DIZ, LM4041DIM7		$\pm 24$		
		LM4041EIM3 LM4041QEIM3 LM4041EIZ, LM4041EIM7		$\pm 36$			
$I_{\text{RMIN}}$	Minimum operating current	$T_A = T_J = 25^\circ\text{C}$		LM4041CIM3 LM4041QCIM3 LM4041CIZ, LM4041CIM7	45	60	$\mu\text{A}$
				LM4041DIM3, LM4041QDIM3, LM4041DIZ, LM4041DIM7 LM4041EIM3, LM4041QEIM3 LM4041EIZ, LM4041EIM7		65	
		$T_A = T_J = T_{\text{MIN}}$ to $T_{\text{MAX}}$		LM4041CIM3 LM4041QCIM3 LM4041CIZ, LM4041CIM7		65	
				LM4041DIM3, LM4041QDIM3, LM4041DIZ, LM4041DIM7 LM4041EIM3, LM4041QEIM3 LM4041EIZ, LM4041EIM7		70	
$\Delta V_R/\Delta T$	$V_R$ Temperature coefficient <sup>(3)</sup>	$I_R = 10\text{mA}$	$T_A = T_J = 25^\circ\text{C}$			$\pm 20$	ppm/ $^\circ\text{C}$
						$\pm 15$	
		$I_R = 1\text{mA}$	$T_A = T_J = T_{\text{MIN}}$ to $T_{\text{MAX}}$	LM4041CIM3 LM4041QCIM3 LM4041CIZ, LM4041CIM7		$\pm 100$	
				LM4041DIM3, LM4041QDIM3, LM4041DIZ, LM4041DIM7 LM4041EIM3, LM4041QEIM3 LM4041EIZ, LM4041EIM7		$\pm 150$	
		$I_R = 100\mu\text{A}$			$\pm 15$		
$\Delta V_R/\Delta I_R$	Reverse breakdown voltage change with operating current change <sup>(4)</sup>	$I_{\text{RMIN}} \leq I_R \leq 1\text{mA}$	$T_A = T_J = 25^\circ\text{C}$	LM4041CIM3 LM4041QCIM3 LM4041CIZ, LM4041CIM7	0.7	1.5	mV
				LM4041DIM3, LM4041QDIM3, LM4041DIZ, LM4041DIM7 LM4041EIM3, LM4041QEIM3 LM4041EIZ, LM4041EIM7		2	
		$T_A = T_J = T_{\text{MIN}}$ to $T_{\text{MAX}}$		LM4041CIM3 LM4041QCIM3 LM4041CIZ, LM4041CIM7		2	
				LM4041DIM3, LM4041QDIM3, LM4041DIZ, LM4041DIM7 LM4041EIM3, LM4041QEIM3 LM4041EIZ, LM4041EIM7		2.5	
	$1\text{mA} \leq I_R \leq 12\text{mA}$	$T_A = T_J = 25^\circ\text{C}$		LM4041CIM3 LM4041QCIM3 LM4041CIZ, LM4041CIM7	2.5	6	mV
				LM4041DIM3, LM4041QDIM3, LM4041DIZ, LM4041DIM7 LM4041EIM3, LM4041QEIM3 LM4041EIZ, LM4041EIM7		8	
		$T_A = T_J = T_{\text{MIN}}$ to $T_{\text{MAX}}$		LM4041CIM3 LM4041QCIM3 LM4041CIZ, LM4041CIM7		8	
				LM4041DIM3, LM4041QDIM3, LM4041DIZ, LM4041DIM7 LM4041EIM3, LM4041QEIM3 LM4041EIZ, LM4041EIM7		10	
$Z_R$	Reverse dynamic impedance	$I_R = 1\text{mA}$ , $f = 120\text{Hz}$ $I_{\text{AC}} = 0.1 I_R$		LM4041CIM3 LM4041QCIM3 LM4041CIZ, LM4041CIM7	0.5	1.5	$\Omega$
				LM4041DIM3, LM4041QDIM3, LM4041DIZ, LM4041DIM7 LM4041EIM3, LM4041QEIM3 LM4041EIZ, LM4041EIM7		2	

## 5.6 LM4041-N LM4041-N-Q1 1.2 Electrical Characteristics (Industrial Temperature Range) (continued)

All limits  $T_A = T_J = 25^\circ\text{C}$ , unless otherwise specified. The grades C, D, and E designate initial reverse breakdown voltage tolerances of  $\pm 0.5\%$ ,  $\pm 1.0\%$ , and  $\pm 2.0\%$ , respectively.

PARAMETER	TEST CONDITIONS	MIN <sup>(1)</sup>	TYP <sup>(2)</sup>	MAX <sup>(1)</sup>	UNIT
$e_N$	Wide band noise $I_R = 100\mu\text{A}$ $10\text{Hz} \leq f \leq 10\text{kHz}$		20		$\mu\text{V}_{\text{RMS}}$
$\Delta V_R$	Reverse breakdown voltage long-term stability $t = 1000\text{ hrs}$ $T = 25^\circ\text{C} \pm 0.1^\circ\text{C}$ $I_R = 100\mu\text{A}$		120		ppm
$V_{\text{HYST}}$	Thermal hysteresis <sup>(5)</sup> $\Delta T = -40^\circ\text{C}$ to $+125^\circ\text{C}$		0.08%		

- Limits are 100% production tested at  $25^\circ\text{C}$ . Limits over temperature are specified through correlation using Statistical Quality Control (SQC) methods. The limits are used to calculate AOQL.
- Typical values are at  $T_J = 25^\circ\text{C}$  and represent most likely parametric norm.
- The over temperature limit for reverse breakdown voltage tolerance is defined as the room temperature reverse breakdown voltage tolerance  $\pm[(\Delta V_R/\Delta T)(\max \Delta T)(V_R)]$ . Where,  $\Delta V_R/\Delta T$  is the  $V_R$  temperature coefficient,  $\max \Delta T$  is the maximum difference in temperature from the reference point of  $25^\circ\text{C}$  to  $T_{\text{MAX}}$  or  $T_{\text{MIN}}$ , and  $V_R$  is the reverse breakdown voltage. The total over-temperature tolerance for the different grades in the industrial temperature range where  $\max \Delta T = 65^\circ\text{C}$  is shown below:  
 A-grade:  $\pm 0.75\% = \pm 0.1\% \pm 100\text{ppm}/^\circ\text{C} \times 65^\circ\text{C}$   
 B-grade:  $\pm 0.85\% = \pm 0.2\% \pm 100\text{ppm}/^\circ\text{C} \times 65^\circ\text{C}$   
 C-grade:  $\pm 1.15\% = \pm 0.5\% \pm 100\text{ppm}/^\circ\text{C} \times 65^\circ\text{C}$   
 D-grade:  $\pm 1.98\% = \pm 1.0\% \pm 150\text{ppm}/^\circ\text{C} \times 65^\circ\text{C}$   
 E-grade:  $\pm 2.98\% = \pm 2.0\% \pm 150\text{ppm}/^\circ\text{C} \times 65^\circ\text{C}$   
 The total over-temperature tolerance for the different grades in the extended temperature range where  $\max \Delta T = 100^\circ\text{C}$  is shown below:  
 B-grade:  $\pm 1.2\% = \pm 0.2\% \pm 100\text{ppm}/^\circ\text{C} \times 100^\circ\text{C}$   
 C-grade:  $\pm 1.5\% = \pm 0.5\% \pm 100\text{ppm}/^\circ\text{C} \times 100^\circ\text{C}$   
 D-grade:  $\pm 2.5\% = \pm 1.0\% \pm 150\text{ppm}/^\circ\text{C} \times 100^\circ\text{C}$   
 E-grade:  $\pm 4.5\% = \pm 2.0\% \pm 150\text{ppm}/^\circ\text{C} \times 100^\circ\text{C}$   
 Therefore, as an example, the A-grade LM4041-N LM4041-N-Q1 1.2 has an over-temperature reverse breakdown voltage tolerance of  $\pm 1.2\text{ V} \times 0.75\% = \pm 9.2\text{mV}$ .
- Load regulation is measured on pulse basis from no load to the specified load current. Output changes due to die temperature change must be taken into account separately.
- Thermal hysteresis is defined as the difference in voltage measured at  $+25^\circ\text{C}$  after cycling to temperature  $-40^\circ\text{C}$  and the  $+25^\circ\text{C}$  measurement after cycling to temperature  $+125^\circ\text{C}$ .

### 5.7 LM4041-N LM4041-N-Q1 1.2 Electrical Characteristics (Extended Temperature Range)

Reverse breakdown change with current

All limits  $T_A = T_J = 25^\circ\text{C}$ , unless otherwise specified. The grades C, D, and E designate initial reverse breakdown voltage tolerance of  $\pm 0.5\%$ ,  $\pm 1.0\%$ , and  $\pm 2.0\%$  respectively.

PARAMETER		TEST CONDITIONS		MIN <sup>(1)</sup>	TYP <sup>(2)</sup>	MAX <sup>(1)</sup>	UNIT
V <sub>R</sub>	Reverse breakdown voltage	I <sub>R</sub> = 100μA			1.225		V
	Reverse breakdown voltage error <sup>(3)</sup>	I <sub>R</sub> = 100μA	T <sub>A</sub> = T <sub>J</sub> = 25°C	LM4041CEM3 LM4041QCEM3		±6	mV
				LM4041DEM3 LM4041QDEM3		±12	
				LM4041EEM3 LM4041QEEM3		±25	
			T <sub>A</sub> = T <sub>J</sub> = T <sub>MIN</sub> to T <sub>MAX</sub>	LM4041CEM3 LM4041QCEM3		±18.4	
				LM4041DEM3 LM4041QDEM3		±31	
LM4041EEM3 LM4041QEEM3		±43					
I <sub>RMIN</sub>	Minimum operating current	T <sub>A</sub> = T <sub>J</sub> = 25°C	LM4041CEM3 LM4041QCEM3	45	60	μA	
			LM4041DEM3, LM4041QDEM3, LM4041EEM3, LM4041QEEM3		65		
	T <sub>A</sub> = T <sub>J</sub> = T <sub>MIN</sub> to T <sub>MAX</sub>	LM4041CEM3 LM4041QCEM3		68			
		LM4041DEM3, LM4041QDEM3, LM4041EEM3, LM4041QEEM3		73			
ΔV <sub>R</sub> /ΔT	VR temperature coefficient <sup>(3)</sup>	I <sub>R</sub> = 10mA	T <sub>A</sub> = T <sub>J</sub> = 25°C		±20	ppm/°C	
			T <sub>A</sub> = T <sub>J</sub> = 25°C		±15		
		I <sub>R</sub> = 1mA	T <sub>A</sub> = T <sub>J</sub> = T <sub>MIN</sub> to T <sub>MAX</sub>	LM4041CEM3 LM4041QCEM3			±100
				LM4041DEM3, LM4041QDEM3, LM4041EEM3, LM4041QEEM3			±150
I <sub>R</sub> = 100μA				±15			

## 5.7 LM4041-N LM4041-N-Q1 1.2 Electrical Characteristics (Extended Temperature Range) (continued)

Reverse breakdown change with current

All limits  $T_A = T_J = 25^\circ\text{C}$ , unless otherwise specified. The grades C, D, and E designate initial reverse breakdown voltage tolerance of  $\pm 0.5\%$ ,  $\pm 1.0\%$ , and  $\pm 2.0\%$  respectively.

PARAMETER	TEST CONDITIONS		MIN <sup>(1)</sup>	TYP <sup>(2)</sup>	MAX <sup>(1)</sup>	UNIT
$\Delta V_R/\Delta I_R$ Reverse breakdown change with current <sup>(4)</sup>	$I_{RMIN} \leq I_R \leq 1.0\text{mA}$	$T_A = T_J = 25^\circ\text{C}$	LM4041DEM3 LM4041QDEM3	0.7	1.5	mV
			LM4041EEM3 LM4041QEEM3		2	
	$T_A = T_J = T_{MIN} \text{ to } T_{MAX}$		LM4041CEM3 LM4041QCEM3		2	mV
			LM4041DEM3, LM4041QDEM3, LM4041EEM3, LM4041QEEM3		2.5	
$\Delta V_R/\Delta I_R$ Reverse breakdown change with current <sup>(4)</sup>	$1\text{mA} \leq I_R \leq 12\text{mA}$	$T_A = T_J = 25^\circ\text{C}$	LM4041CEM3 LM4041QCEM3	2.5	6	mV
			LM4041DEM3, LM4041QDEM3, LM4041EEM3, LM4041QEEM3		8	
	$T_A = T_J = T_{MIN} \text{ to } T_{MAX}$		LM4041CEM3 LM4041QCEM3		8	mV
			LM4041DEM3, LM4041QDEM3, LM4041EEM3, LM4041QEEM3		10	
$Z_R$ Reverse dynamic impedance	$I_R = 1\text{mA}, f = 120\text{Hz}, I_{AC} = 0.1 I_R$	$T_A = T_J = 25^\circ\text{C}$		0.5		$\Omega$
		$T_A = T_J = T_{MIN} \text{ to } T_{MAX}$	LM4041CEM3 LM4041QCEM3		1.5	
			LM4041DEM3, LM4041QDEM3, LM4041EEM3, LM4041QEEM3		2	
$e_N$ Noise voltage	$I_R = 100\mu\text{A}$ $10\text{Hz} \leq f \leq 10\text{kHz}$			20		$\mu\text{V}_{rms}$
$\Delta V_R$ Long-term stability (non-cumulative)	$t = 1000 \text{ hrs}$ $T = 25^\circ\text{C} \pm 0.1^\circ\text{C}$ $I_R = 100\mu\text{A}$			120		ppm
$V_{HYST}$ Thermal hysteresis <sup>(5)</sup>	$\Delta T = -40^\circ\text{C} \text{ to } +125^\circ\text{C}$			0.08%		

(1) Limits are 100% production tested at  $25^\circ\text{C}$ . Limits over temperature are made sure through correlation using Statistical Quality Control (SQC) methods. The limits are used to calculate AOQL.

(2) Typical values are at  $T_J = 25^\circ\text{C}$  and represent most likely parametric norm.

(3) The over temperature limit for reverse breakdown voltage tolerance is defined as the room temperature reverse breakdown voltage tolerance  $\pm[(\Delta V_R/\Delta T)(\max \Delta T)(V_R)]$ . Where,  $\Delta V_R/\Delta T$  is the  $V_R$  temperature coefficient,  $\max \Delta T$  is the maximum difference in temperature from the reference point of  $25^\circ\text{C}$  to  $T_{MAX}$  or  $T_{MIN}$ , and  $V_R$  is the reverse breakdown voltage. The total over-temperature tolerance for the different grades in the industrial temperature range where  $\max \Delta T = 65^\circ\text{C}$  is shown below:

A-grade:  $\pm 0.75\% = \pm 0.1\% \pm 100\text{ppm}/^\circ\text{C} \times 65^\circ\text{C}$

B-grade:  $\pm 0.85\% = \pm 0.2\% \pm 100\text{ppm}/^\circ\text{C} \times 65^\circ\text{C}$

C-grade:  $\pm 1.15\% = \pm 0.5\% \pm 100\text{ppm}/^\circ\text{C} \times 65^\circ\text{C}$

D-grade:  $\pm 1.98\% = \pm 1.0\% \pm 150\text{ppm}/^\circ\text{C} \times 65^\circ\text{C}$

E-grade:  $\pm 2.98\% = \pm 2.0\% \pm 150\text{ppm}/^\circ\text{C} \times 65^\circ\text{C}$

The total over-temperature tolerance for the different grades in the extended temperature range where  $\max \Delta T = 100^\circ\text{C}$  is shown below:

B-grade:  $\pm 1.2\% = \pm 0.2\% \pm 100\text{ppm}/^\circ\text{C} \times 100^\circ\text{C}$

C-grade:  $\pm 1.5\% = \pm 0.5\% \pm 100\text{ppm}/^\circ\text{C} \times 100^\circ\text{C}$

D-grade:  $\pm 2.5\% = \pm 1.0\% \pm 150\text{ppm}/^\circ\text{C} \times 100^\circ\text{C}$

E-grade:  $\pm 4.5\% = \pm 2.0\% \pm 150\text{ppm}/^\circ\text{C} \times 100^\circ\text{C}$

Therefore, as an example, the A-grade LM4041-N LM4041-N-Q1 1.2 has an over-temperature reverse breakdown voltage tolerance of  $\pm 1.2\text{ V} \times 0.75\% = \pm 9.2\text{mV}$ .

**LM4041-N, LM4041-N-Q1**SNOS641I – OCTOBER 1999 – REVISED JULY 2025

---

- (4) Load regulation is measured on pulse basis from no load to the specified load current. Output changes due to die temperature change must be taken into account separately.
- (5) Thermal hysteresis is defined as the difference in voltage measured at +25°C after cycling to temperature –40°C and the +25°C measurement after cycling to temperature +125°C.

## 5.8 LM4041-N LM4041-N-Q1 ADJ (Adjustable) Electrical Characteristics (Industrial Temperature Range)

All limits  $T_J = 25^\circ\text{C}$ , unless otherwise specified (SOT-23, see<sup>(1)</sup>),

$I_{RMIN} \leq I_R \leq 12\text{mA}$ ,  $V_{REF} \leq V_{OUT} \leq 10\text{V}$ . The grades C and D designate initial Reference Voltage Tolerances of  $\pm 0.5\%$  and  $\pm 1\%$ , respectively for  $V_{OUT} = 5\text{V}$ .

PARAMETER		TEST CONDITIONS			MIN <sup>(2)</sup>	TYP <sup>(3)</sup>	MAX <sup>(2)</sup>	UNIT
$V_{REF}$	Reference voltage	$I_R = 100\mu\text{A}$ , $V_{OUT} = 5\text{V}$			1.233			V
	Reference voltage tolerance <sup>(4)</sup>	$I_R = 100\mu\text{A}$ , $V_{OUT} = 5\text{V}$	$T_J = 25^\circ\text{C}$	LM4041CIM3 LM4041QCIM3 LM4041CIZ, LM4041CIM7	$\pm 6.2$		mV	
				LM4041DIM3 LM4041QDIM3 LM4041DIZ, LM4041DIM7	$\pm 12$			
			$T_A = T_J = T_{MIN}$ to $T_{MAX}$	LM4041CIM3 LM4041QCIM3 LM4041CIZ, LM4041CIM7	$\pm 14$			
LM4041DIM3 LM4041QDIM3 LM4041DIZ, LM4041DIM7	$\pm 24$							
$I_{RMIN}$	Minimum operating current		$T_J = 25^\circ\text{C}$	LM4041CIM3 LM4041QCIM3 LM4041CIZ, LM4041CIM7	45	60	$\mu\text{A}$	
				LM4041DIM3 LM4041QDIM3 LM4041DIZ, LM4041DIM7	65			
			$T_A = T_J = T_{MIN}$ to $T_{MAX}$	LM4041CIM3 LM4041QCIM3 LM4041CIZ, LM4041CIM7	65			
				LM4041DIM3 LM4041QDIM3 LM4041DIZ, LM4041DIM7	70			
$\Delta V_{REF}/\Delta I_R$	Reference voltage change with operating current change <sup>(5)</sup>	$I_{RMIN} \leq I_R \leq 1\text{mA}$ SOT-23: $V_{OUT} \geq 1.6\text{V}$ <sup>(1)</sup>	$T_J = 25^\circ\text{C}$	LM4041CIM3 LM4041QCIM3 LM4041CIZ, LM4041CIM7	0.7	1.5	mV	
				LM4041DIM3 LM4041QDIM3 LM4041DIZ, LM4041DIM7	2			
			$T_A = T_J = T_{MIN}$ to $T_{MAX}$	LM4041CIM3 LM4041QCIM3 LM4041CIZ, LM4041CIM7	2			
				LM4041DIM3 LM4041QDIM3 LM4041DIZ, LM4041DIM7	2.5			
		$1\text{mA} \leq I_R \leq 12\text{mA}$ SOT-23: $V_{OUT} \geq 1.6\text{V}$ <sup>(1)</sup>	$T_J = 25^\circ\text{C}$		LM4041CIM3 LM4041QCIM3 LM4041CIZ, LM4041CIM7	2		mV
					LM4041DIM3 LM4041QDIM3 LM4041DIZ, LM4041DIM7	4		
			$T_A = T_J = T_{MIN}$ to $T_{MAX}$	LM4041CIM3 LM4041QCIM3 LM4041CIZ, LM4041CIM7	6			
				LM4041DIM3 LM4041QDIM3 LM4041DIZ, LM4041DIM7	8			
$\Delta V_{REF}/\Delta V_O$	Reference voltage change with output voltage change	$I_R = 1\text{mA}$	$T_J = 25^\circ\text{C}$	LM4041CIM3 LM4041QCIM3 LM4041CIZ, LM4041CIM7	-1.55	-2	mV/V	
				LM4041DIM3 LM4041QDIM3 LM4041DIZ, LM4041DIM7	-2.5			
			$T_A = T_J = T_{MIN}$ to $T_{MAX}$	LM4041CIM3 LM4041QCIM3 LM4041CIZ, LM4041CIM7	-2.5			
				LM4041CIM3 LM4041QCIM3 LM4041CIZ, LM4041CIM7	-3			
$I_{FB}$	Feedback current		$T_J = 25^\circ\text{C}$	LM4041CIM3 LM4041QCIM3 LM4041CIZ, LM4041CIM7	60	100	nA	
				LM4041DIM3 LM4041QDIM3 LM4041DIZ, LM4041DIM7	150			
			$T_A = T_J = T_{MIN}$ to $T_{MAX}$	120				

## 5.8 LM4041-N LM4041-N-Q1 ADJ (Adjustable) Electrical Characteristics (Industrial Temperature Range) (continued)

All limits  $T_J = 25^\circ\text{C}$ , unless otherwise specified (SOT-23, see<sup>(1)</sup>),

$I_{R\text{MIN}} \leq I_R \leq 12\text{mA}$ ,  $V_{\text{REF}} \leq V_{\text{OUT}} \leq 10\text{V}$ . The grades C and D designate initial Reference Voltage Tolerances of  $\pm 0.5\%$  and  $\pm 1\%$ , respectively for  $V_{\text{OUT}} = 5\text{V}$ .

PARAMETER	TEST CONDITIONS		MIN <sup>(2)</sup>	TYP <sup>(3)</sup>	MAX <sup>(2)</sup>	UNIT		
$\Delta V_{\text{REF}}/\Delta T$	Average reference voltage temperature coefficient <sup>(4)</sup>	$V_{\text{OUT}} = 5\text{V}$	$I_R = 10\text{mA}$		20	ppm/ $^\circ\text{C}$		
			$I_R = 1\text{mA}$	$T_J = 25^\circ\text{C}$			15	
				$T_A = T_J = T_{\text{MIN}}$ to $T_{\text{MAX}}$	LM4041CIM3 LM4041QCIM3 LM4041CIZ, LM4041CIM7			$\pm 100$
					LM4041DIM3 LM4041QDIM3 LM4041DIZ, LM4041DIM7			$\pm 150$
$I_R = 100\mu\text{A}$			15					
$Z_{\text{OUT}}$	Dynamic output impedance	$I_R = 1\text{mA}$ , $f = 120\text{Hz}$ , $I_{\text{AC}} = 0.1 I_R$		0.3	$\Omega$			
		$V_{\text{OUT}} = V_{\text{REF}}$ $V_{\text{OUT}} = 10\text{V}$		2				
$e_N$	Wide band noise	$V_{\text{OUT}} = V_{\text{REF}}$ $I_R = 100\mu\text{A}$ $10\text{Hz} \leq f \leq 10\text{kHz}$		20	$\mu\text{V}_{\text{RMS}}$			
$\Delta V_{\text{REF}}$	Reference voltage long-term stability	$t = 1000\text{ hrs}$ , $I_R = 100\mu\text{A}$ , $T = 25^\circ\text{C} \pm 0.1^\circ\text{C}$		120	ppm			
$V_{\text{HYST}}$	Thermal hysteresis <sup>(6)</sup>	$\Delta T = -40^\circ\text{C}$ to $+125^\circ\text{C}$		0.08%				

- (1) When  $V_{\text{OUT}} \leq 1.6\text{V}$ , the LM4041-N LM4041-N-Q1 ADJ in the SOT-23 package must operate at reduced  $I_R$ . This is caused by the series resistance of the die attach between the die (–) output and the package (–) output pin. See the [Output Saturation \(SOT-23 only\)](#) curve in the [Typical Characteristics](#) section.
- (2) Limits are 100% production tested at  $25^\circ\text{C}$ . Limits over temperature are made sure through correlation using Statistical Quality Control (SQC) methods. The limits are used to calculate AOQL.
- (3) Typical values are at  $T_J = 25^\circ\text{C}$  and represent most likely parametric norm.
- (4) Reference voltage and temperature coefficient can change with output voltage. See [Section 5.10](#) curves.
- (5) Load regulation is measured on pulse basis from no load to the specified load current. Output changes due to die temperature change must be taken into account separately.
- (6) Thermal hysteresis is defined as the difference in voltage measured at  $+25^\circ\text{C}$  after cycling to temperature  $-40^\circ\text{C}$  and the  $+25^\circ\text{C}$  measurement after cycling to temperature  $+125^\circ\text{C}$ .

## 5.9 LM4041-N LM4041-N-Q1 ADJ (Adjustable) Electrical Characteristics (Extended Temperature Range)

All limits  $T_J = 25^\circ\text{C}$ , unless otherwise specified (SOT-23, see<sup>(1)</sup>),  $I_{R\text{MIN}} \leq I_R \leq 12\text{mA}$ ,  $V_{\text{REF}} \leq V_{\text{OUT}} \leq 10\text{V}$ . The grades C and D designate initial Reference Voltage Tolerances of  $\pm 0.5\%$  and  $\pm 1\%$ , respectively for  $V_{\text{OUT}} = 5\text{V}$ .

PARAMETER		TEST CONDITIONS		MIN <sup>(2)</sup>	TYP <sup>(3)</sup>	MAX <sup>(2)</sup>	UNIT			
$V_{\text{REF}}$	Reference voltage	$I_R = 100\mu\text{A}$ , $V_{\text{OUT}} = 5\text{V}$		1.233			V			
	Reference voltage tolerance <sup>(4)</sup>	$I_R = 100\mu\text{A}$ , $V_{\text{OUT}} = 5\text{V}$	$T_J = 25^\circ\text{C}$	LM4041CEM3 LM4041QCEM3	$\pm 6.2$		mV			
			$T_A = T_J = T_{\text{MIN}}$ to $T_{\text{MAX}}$	LM4041DEM3 LM4041QDEM3	$\pm 12$					
				LM4041CEM3 LM4041QCEM3	$\pm 18$					
LM4041DEM3 LM4041QDEM3	$\pm 30$									
$I_{R\text{MIN}}$	Minimum operating current	$T_J = 25^\circ\text{C}$	$T_A = T_J = T_{\text{MIN}}$ to $T_{\text{MAX}}$	LM4041CEM3 LM4041QCEM3	45	60	$\mu\text{A}$			
				LM4041DEM3 LM4041QDEM3	65					
				LM4041CEM3 LM4041QCEM3	68					
				LM4041DEM3 LM4041QDEM3	73					
$\Delta V_{\text{REF}}/\Delta I_R$	Reference voltage change with operating current change <sup>(5)</sup>	$I_{R\text{MIN}} \leq I_R \leq 1\text{mA}$ SOT-23: $V_{\text{OUT}} \geq 1.6\text{V}$ <sup>(1)</sup>	$T_J = 25^\circ\text{C}$	$T_A = T_J = T_{\text{MIN}}$ to $T_{\text{MAX}}$	LM4041CEM3 LM4041QCEM3	0.7	1.5	mV		
					LM4041DEM3 LM4041QDEM3	2				
					LM4041CEM3 LM4041QCEM3	2				
					LM4041DEM3 LM4041QDEM3	2.5				
	$1\text{mA} \leq I_R \leq 12\text{mA}$ SOT-23: $V_{\text{OUT}} \geq 1.6\text{V}$ <sup>(1)</sup>	$T_J = 25^\circ\text{C}$	$T_A = T_J = T_{\text{MIN}}$ to $T_{\text{MAX}}$	LM4041CEM3 LM4041QCEM3	2	8	mV			
				LM4041DEM3 LM4041QDEM3	10					
				LM4041CEM3 LM4041QCEM3	6					
				LM4041DEM3 LM4041QDEM3	8					
$\Delta V_{\text{REF}}/\Delta V_O$	Reference voltage change with output voltage change	$I_R = 1\text{mA}$	$T_J = 25^\circ\text{C}$	$T_A = T_J = T_{\text{MIN}}$ to $T_{\text{MAX}}$	LM4041CEM3 LM4041QCEM3	-1.55	-2	mV/V		
					LM4041DEM3 LM4041QDEM3	-2.5				
					LM4041CEM3 LM4041QCEM3	-3				
					LM4041DEM3 LM4041QDEM3	-4				
$I_{\text{FB}}$	Feedback current	$T_J = 25^\circ\text{C}$	$T_A = T_J = T_{\text{MIN}}$ to $T_{\text{MAX}}$	LM4041CEM3 LM4041QCEM3	60	100	nA			
				LM4041DEM3 LM4041QDEM3	150					
				LM4041CEM3 LM4041QCEM3	120					
				LM4041DEM3 LM4041QDEM3	200					
$\Delta V_{\text{REF}}/\Delta T$	Average reference voltage temperature coefficient <sup>(4)</sup>	$V_{\text{OUT}} = 5\text{V}$	$I_R = 10\text{mA}$	$T_J = 25^\circ\text{C}$	20		ppm/ $^\circ\text{C}$			
					$I_R = 1\text{mA}$	$T_A = T_J = T_{\text{MIN}}$ to $T_{\text{MAX}}$		LM4041CEM3 LM4041QCEM3	$\pm 100$	
								LM4041DEM3 LM4041QDEM3	$\pm 150$	
								$I_R = 100\mu\text{A}$	15	
$Z_{\text{OUT}}$	Dynamic output impedance	$I_R = 1\text{mA}$ , $f = 120\text{Hz}$ , $I_{\text{AC}} = 0.1 I_R$	$V_{\text{OUT}} = V_{\text{REF}}$	$T_J = 25^\circ\text{C}$	0.3		$\Omega$			
					$V_{\text{OUT}} = 10\text{V}$	2				
						2				
$e_N$	Wide band noise	$I_R = 100\mu\text{A}$ , $10\text{Hz} \leq f \leq 10\text{kHz}$	$V_{\text{OUT}} = V_{\text{REF}}$		20		$\mu\text{V}_{\text{RMS}}$			
$\Delta V_{\text{REF}}$	Reference voltage long-term stability	$t = 1000\text{ hrs}$ , $I_R = 100\mu\text{A}$ , $T = 25^\circ\text{C} \pm 0.1^\circ\text{C}$			120		ppm			
$V_{\text{HYST}}$	Thermal hysteresis <sup>(6)</sup>	$\Delta T = -40^\circ\text{C}$ to $+125^\circ\text{C}$			0.08%					

- (1) When  $V_{\text{OUT}} \leq 1.6\text{V}$ , the LM4041-N LM4041-N-Q1 ADJ in the SOT-23 package must operate at reduced  $I_R$ . This is caused by the series resistance of the die attach between the die (-) output and the package (-) output pin. See the [Output Saturation \(SOT-23 only\)](#) curve in the [Typical Characteristics](#) section.
- (2) Limits are 100% production tested at  $25^\circ\text{C}$ . Limits over temperature are made sure through correlation using Statistical Quality Control (SQC) methods. The limits are used to calculate AOQL.
- (3) Typical values are at  $T_J = 25^\circ\text{C}$  and represent most likely parametric norm.
- (4) Reference voltage and temperature coefficient can change with output voltage. See [Section 5.10](#) curves.
- (5) Load regulation is measured on pulse basis from no load to the specified load current. Output changes due to die temperature change must be taken into account separately.
- (6) Thermal hysteresis is defined as the difference in voltage measured at  $+25^\circ\text{C}$  after cycling to temperature  $-40^\circ\text{C}$  and the  $+25^\circ\text{C}$  measurement after cycling to temperature  $+125^\circ\text{C}$ .

### 5.10 Typical Characteristics

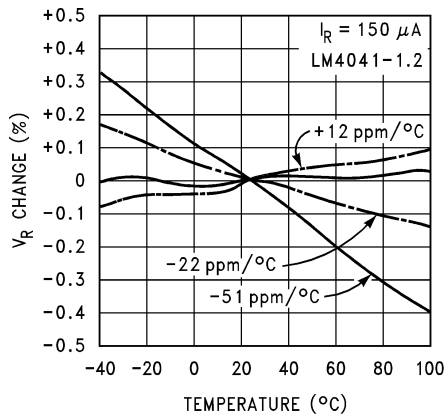

Figure 5-1. Temperature Drift for Different Average Temperature Coefficient

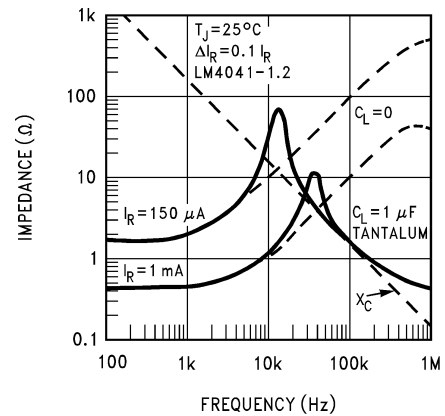

Figure 5-2. Output Impedance vs Frequency

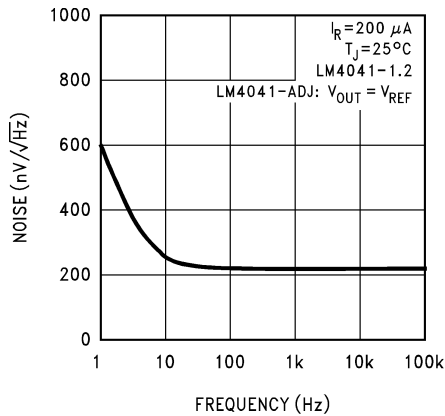

Figure 5-3. Noise Voltage

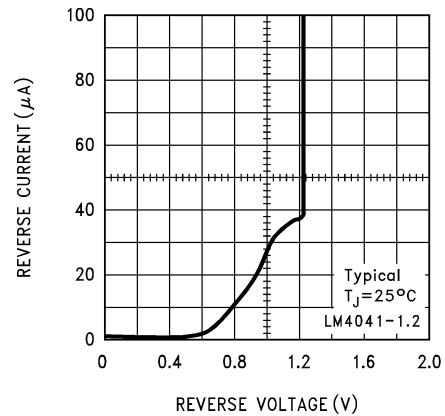

Figure 5-4. Reverse Characteristics and Minimum Operating Current

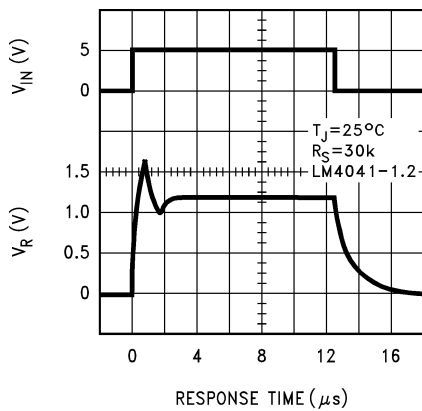

Figure 5-5. Start-Up Characteristics

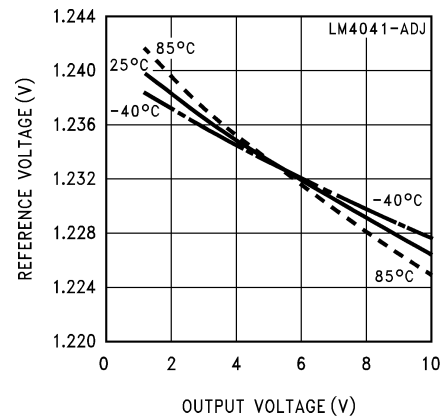
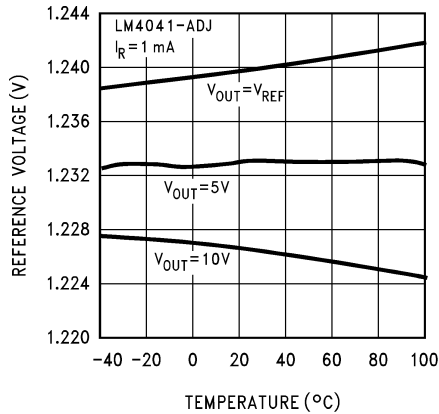
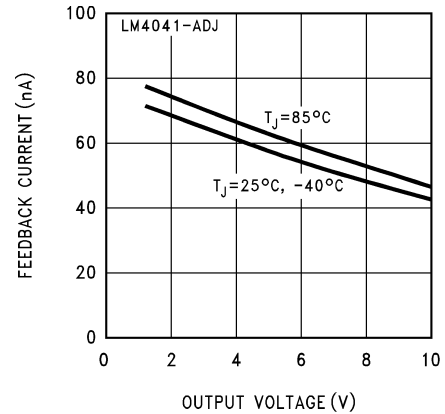

Figure 5-6. Reference Voltage vs Output Voltage and Temperature

### 5.10 Typical Characteristics (continued)



**Figure 5-7. Reference Voltage vs Temperature and Output Voltage**



**Figure 5-8. Feedback Current vs Output Voltage and Temperature**

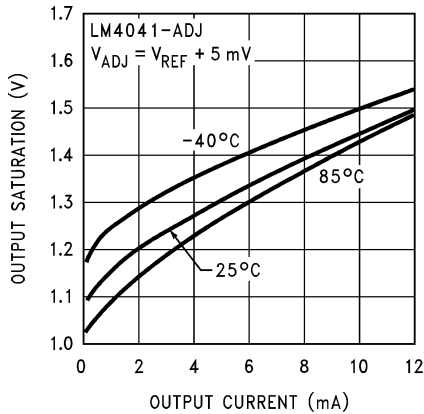

**Figure 5-9. Output Saturation (SOT-23 Only)**

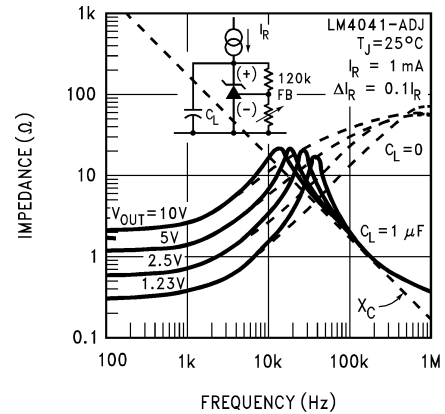

**Figure 5-10. Output Impedance vs Frequency**

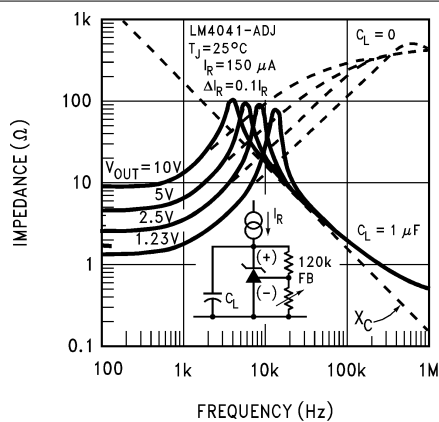

**Figure 5-11. Output Impedance vs Frequency**

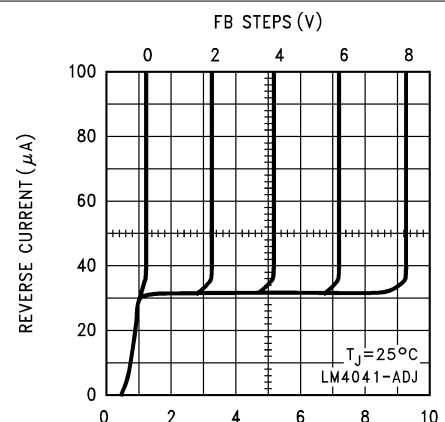

**Figure 5-12. Reverse Characteristics**

### 5.10 Typical Characteristics (continued)

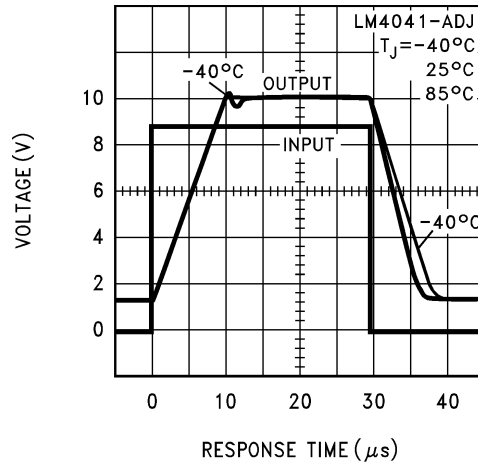
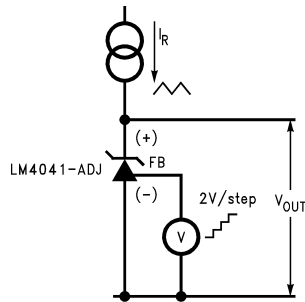
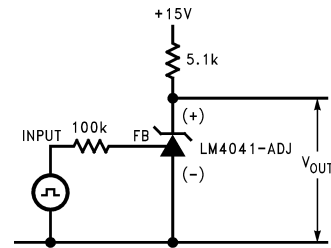

Figure 5-13. Large Signal Response

## 6 Parameter Measurement Information



**Figure 6-1. Adjustable Output Test Circuit**



**Figure 6-2. Line Transient Test Circuit**

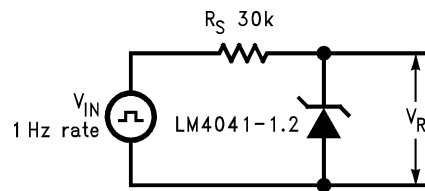

**Figure 6-3. Start-Up and Shutdown Test Circuit**

## 7 Detailed Description

### 7.1 Overview

The LM4041-N LM4041-N-Q1 is a precision micro-power shunt voltage reference available in both a fixed and output voltage and adjustable output voltage options. The part has three different packages available to meet small footprint requirements. The part is also available in five different tolerance grades.

### 7.2 Functional Block Diagram

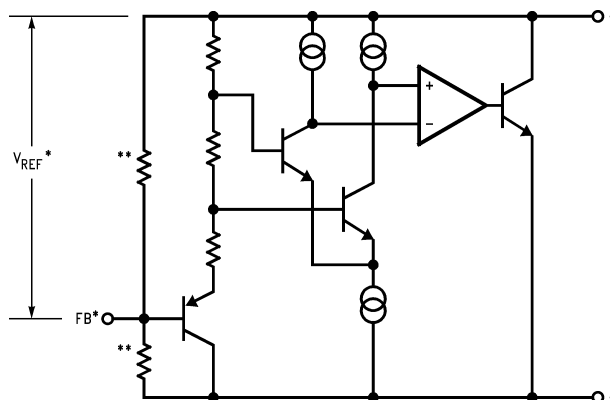

\*LM4041-N ADJ only \*\*LM4041-N 1.2 only

### 7.3 Feature Description

The LM4041-N LM4041-N-Q1 is effectively a precision Zener diode. The part requires a small quiescent current for regulation, and regulates the output voltage by shunting more or less current to ground, depending on input voltage and load. The only external component requirement is a resistor between the cathode and the input voltage to set the input current. An external capacitor can be used on the input or output, but is not required.

### 7.4 Device Functional Modes

The LM4041-N LM4041-N-Q1 has fixed output voltage options as well as adjustable output voltage options. The fixed output parts can only be used in closed-loop operation, as the feedback is internal. The adjustable option parts are most commonly operated in closed-loop mode, where the feedback node is tied to the output voltage through a resistor divider. The output voltage remains as long as  $I_R$  is between  $I_{RMIN}$  and  $I_{RMAX}$ ; see [Section 5.5](#). This part can also be used in open-loop mode to act as a comparator, driving the feedback node from another voltage source.

## 8 Application and Implementation

### Note

Information in the following applications sections is not part of the TI component specification, and TI does not warrant its accuracy or completeness. TI's customers are responsible for determining suitability of components for their purposes, as well as validating and testing their design implementation to confirm system functionality.

### 8.1 Application Information

The LM4041-N LM4041-N-Q1 is a precision micro-power curvature-corrected band gap shunt voltage reference. For space-critical applications, the LM4041-N LM4041-N-Q1 is available in the sub-miniature SOT-23 and SC70 surface-mount package. The LM4041-N LM4041-N-Q1 has been designed for stable operation without the need of an external capacitor connected between the + pin and the – pin. If, however, a bypass capacitor is used, the LM4041-N LM4041-N-Q1 remains stable. Design effort is further reduced with the choice of either a fixed 1.2V or an adjustable reverse breakdown voltage. The minimum operating current is 60µA for the LM4041-N LM4041-N-Q1 1.2V and the LM4041-N LM4041-N-Q1 ADJ. Both versions have a maximum operating current of 12mA.

The LM4041-N LM4041-N-Q1 devices using the SOT-23 package have pin 3 connected as the (–) output through the die attach interface of the package. Therefore, pin 3 of the LM4041-N LM4041-N-Q1 1.2 must be left floating or connected to pin 2 and pin 3 of the LM4041-N LM4041-N-Q1 ADJ pin out.

The LM4041-N LM4041-N-Q1 devices using the SC70 package have pin 2 connected as the (–) output through the die attach interface of the package. Therefore, the LM4041-N LM4041-N-Q1 pin 2 of the LM4041-N LM4041-N-Q1 1.2 must be left floating or connected to pin 1, and the pin 2 of the LM4041-N LM4041-N-Q1 ADJ is the (–) output.

The typical thermal hysteresis specification is defined as the change in 25°C voltage measured after thermal cycling. The device is thermal cycled to temperature –40°C and then measured at +25°C. Next the device is thermal cycled to temperature 125°C and again measured at 25°C. The resulting  $V_{OUT}$  delta shift between the 25°C measurements is thermal hysteresis. Thermal hysteresis is common in precision references and is induced by thermal-mechanical package stress. Changes in environmental storage temperature, operating temperature and board mounting temperature are all factors that can contribute to thermal hysteresis.

In a conventional shunt regulator application ([Figure 8-1](#)), an external series resistor ( $R_S$ ) is connected between the supply voltage and the LM4041-N LM4041-N-Q1.  $R_S$  determines the current that flows through the load ( $I_L$ ) and the LM4041-N LM4041-N-Q1 ( $I_Q$ ). Because load current and supply voltage can vary,  $R_S$  must be small enough to supply at least the minimum acceptable  $I_Q$  to the LM4041-N LM4041-N-Q1 even when the supply voltage is at the minimum and the load current is at the maximum value. When the supply voltage is at the maximum and  $I_L$  is at the minimum,  $R_S$  must be large enough so that the current flowing through the LM4041-N is less than 12mA.

$R_S$  must be selected based on the supply voltage, ( $V_S$ ), the desired load and operating current, ( $I_L$  and  $I_Q$ ), and the reverse breakdown voltage of the LM4041-N LM4041-N-Q1,  $V_R$ .

$$R_S = \frac{V_S - V_R}{I_L + I_Q} \quad (1)$$

The output voltage of the LM4041-N LM4041-N-Q1 SDJ can be adjusted to any value in the range of 1.24V through 10V. The output voltage is a function of the internal reference voltage ( $V_{REF}$ ) and the ratio of the external feedback resistors as shown in [Figure 8-3](#). The output voltage is found using [Equation 2](#).

$$V_O = V_{REF}[(R_2/R_1) + 1] \quad (2)$$

where

- $V_O$  is the output voltage.

The actual value of the internal  $V_{REF}$  is a function of  $V_O$ . The *corrected*  $V_{REF}$  is determined by [Equation 3](#).

$$V_{REF} = \Delta V_O (\Delta V_{REF}/\Delta V_O) + V_Y \quad (3)$$

where

- $V_Y = 1.240V$
- and  $\Delta V_O = (V_O - V_Y)$

$\Delta V_{REF}/\Delta V_O$  is found in the electrical characteristics tables in the [Section 5](#) and is typically  $-1.55mV/V$ . You can get a more accurate indication of the output voltage by replacing the value of  $V_{REF}$  in [Equation 2](#) with the value found using [Equation 3](#).

#### Note

The actual output voltage can deviate from that predicted using the typical value of  $\Delta V_{REF} / \Delta V_O$  in [Equation 3](#). For C-grade parts, the worst-case  $\Delta V_{REF} / \Delta V_O$  is  $-2.5mV/V$ . For D-grade parts, the worst-case  $\Delta V_{REF} / \Delta V_O$  is  $-3.0mV/V$ .

## 8.2 Typical Applications

### 8.2.1 Shunt Regulator

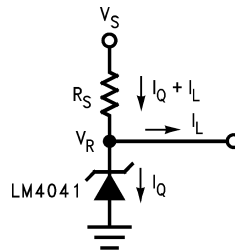

Figure 8-1. Shunt Regulator

#### 8.2.1.1 Design Requirements

$$V_{IN} > V_{OUT}$$

Select  $R_S$  with [Equation 4](#).

$$I_{RMIN} < I_R < I_{RMAX} = 15mA \quad (4)$$

See the electrical characteristics tables in the [Section 5](#) for minimum operating current for each voltage option and grade.

#### 8.2.1.2 Detailed Design Procedure

The resistor  $R_S$  must be selected such that current  $I_R$  remains in the operational region of the part for the entire  $V_{IN}$  range and load current range. At the maximum, the  $R_S$  must be small enough for  $I_R$  to remain above  $I_{RMIN}$ . The other extreme is when  $V_{IN}$  at the maximum and the load at the minimum; the  $R_S$  must be large enough to maintain  $I_R < I_{RMAX}$ . If unsure, try using  $0.1mA \leq I_R \leq 1mA$  as starting point. Just remember the value of  $I_R$  varies with input and voltage load.

Use equations [Equation 5](#) and [Equation 6](#) to set  $R_S$  between  $R_{S\_MIN}$  and  $R_{S\_MAX}$ .

$$R_{S\_MIN} = \frac{V_{IN\_MAX} - V_{OUT}}{I_{LOAD\_MIN} + I_{R\_MAX}} \quad (5)$$

$$R_{S\_MAX} = \frac{V_{IN\_MIN} - V_{OUT}}{I_{LOAD\_MAX} + I_{R\_MIN}} \quad (6)$$

### 8.2.1.3 Application Curve

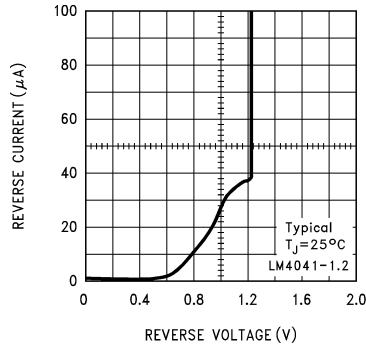
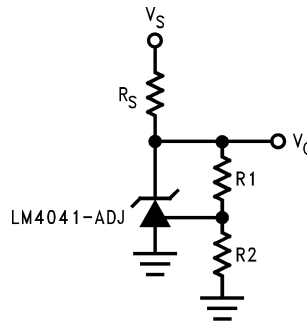

Figure 8-2. Reverse Characteristics and Minimum Operating Current

### 8.2.2 Adjustable Shunt Regulator



$$V_O = V_{REF}[(R_2/R_1) + 1]$$

Figure 8-3. Adjustable Shunt Regulator

#### 8.2.2.1 Design Requirements

$$V_{IN} > V_{OUT}$$

$$V_{OUT} = 2.5V$$

Select  $R_S$  with [Equation 7](#).

$$I_{RMIN} < I_R < I_{RMAX} \quad (7)$$

where

- $I_{RMAX} = 15mA$

See the electrical characteristics tables in the [Section 5](#) for minimum operating current for each voltage option and grade. When the output voltage,  $V_Z$ , is set below 2.5V on adjustable versions of LM4041-N and LM4041-N-Q1, the device can experience increased reference voltage change with output voltage change ( $\Delta V_{REF}/\Delta V_{KA}$ ) when compared to output voltages set equal to or above 2.5V

#### 8.2.2.2 Detail Design Procedure

Select a value of  $R_S$  based on the same method shown in [Section 8.2.1.2](#).

Set feedback resistors  $R_1$  and  $R_2$  for a resistor divider on the equation shown in [Section 8.1](#) that is reproduced here as [Equation 8](#).

$$V_{OUT} + V_{REF} \times ((R_2/R_1)+1) \quad (8)$$

So, for a 2.5V reference, of  $V_{REF}$  is 1.24V, then  $R_2/R_1 = 1.01$ . Select  $R_2 = 1.01k\Omega$  and  $R_1 = 1.0k\Omega$ .

### 8.2.3 Bounded Amplifier

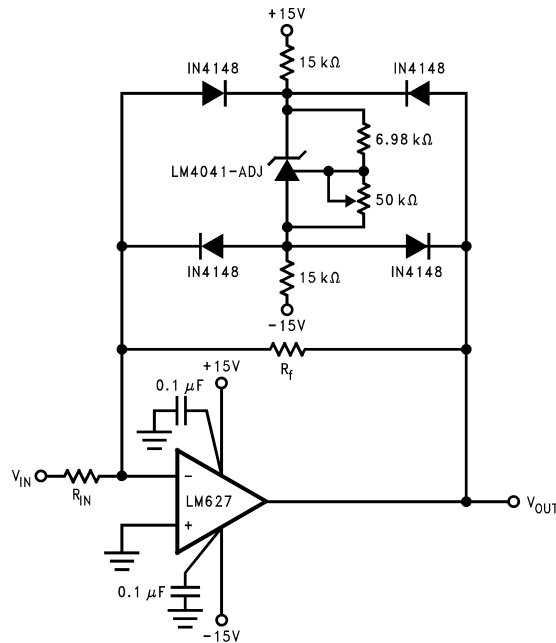

Bounded amplifier reduces saturation-induced delays and can prevent succeeding stage damage. Nominal clamping voltage is  $\pm V_O$  (the reverse breakdown voltage of the LM4041-N)  $+2$  diode  $V_F$ .

**Figure 8-4. Bounded Amplifier**

#### 8.2.3.1 Design Requirements

Design an amplifier with output clamped at  $\pm 11.5V$ .

#### 8.2.3.2 Detail Design Procedure

With amplifier rails of  $\pm 15V$ , the output can be bound to  $\pm 11.5V$  with the LM4041-N LM4041-N-Q1 adjustable set for 10V and two nominal diode voltage drops of 0.7V.

$$V_{OUTBOUND} = 2 \times V_{FWD} + V_Z \quad (9)$$

$$V_{OUTBOUND} = 1.4V + 10V \quad (10)$$

Select  $R_S = 15k\Omega$  to keep  $I_R$  low. Calculate  $I_R$  to confirm  $R_S$  selection.

Use [Equation 11](#), but in this case, take the negative supply into account.

$$I_R = (V_{IN} - V_{OUT}) / R \quad (11)$$

$$I_R = (V_{IN+} - V_{IN-} - V_{OUT}) / R = (30V - 10V) / (R_{S1} + R_{S2}) = 20V / 30k\Omega = 0.667mA \quad (12)$$

This is an acceptable value for  $I_R$  that does not draw excessive current, but prevents the part from being starved for current.

### 8.2.3.3 Application Curve

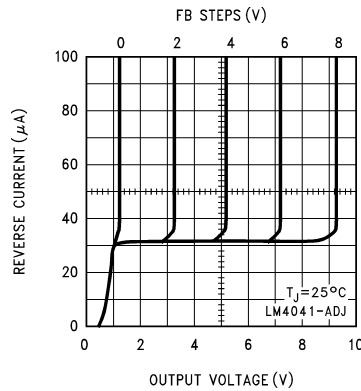

Figure 8-5. Reverse Characteristics

### 8.2.4 Voltage Level Detector

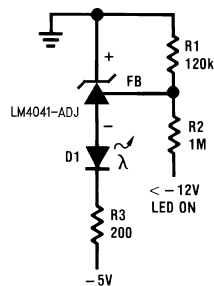

Figure 8-6. Voltage Level Detector

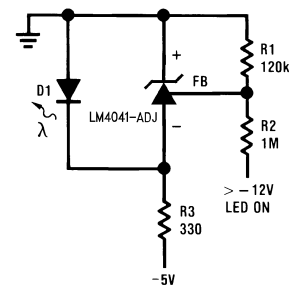

Figure 8-7. Voltage Level Detector

#### 8.2.4.1 Design Procedure

Turn on an LED when voltage is above or below  $-12\text{V}$ .

#### 8.2.4.2 Detail Design Procedure

Use the LM4041-N LM4041-N-Q1 in an open-loop configuration, where the feedback node is tied to a voltage divider driven by the input signal. The voltage divider is set such that when the input signal is at  $-12\text{V}$ , the feedback node is  $-1.24\text{V}$ . The high gain of the LM4041-N LM4041-N-Q1 enables the device to act like a comparator.

## 8.2.5 Precision Current Sink and Source

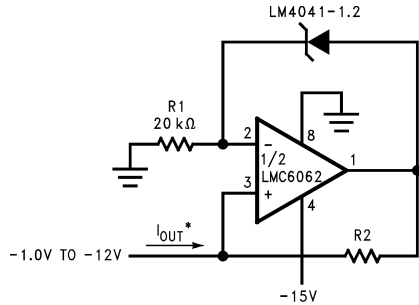

$$I_{OUT} = \frac{1.2V}{R_2}$$

**Figure 8-8. Precision 1µA to 1mA Current Sink**

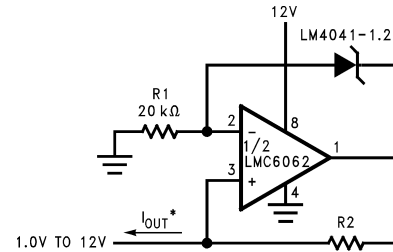

**Figure 8-9. Precision 1µA to 1mA Current Sources**

### 8.2.5.1 Design Requirements

Create precision 1mA current sink and 1mA current source.

### 8.2.5.2 Detailed Design Procedure

Set R1 such that the current through the shunt reference,  $I_R$ , is greater than  $I_{RMIN}$ .

$$I_{OUT} = V_{OUT} / R_2 \tag{13}$$

where

- $V_{OUT}$  is the voltage drop across the shunt reference

In this case,  $I_{OUT} = 1.2 / R_2$ .

### 8.2.6 100mA Current Source

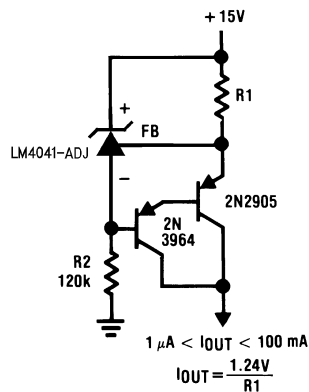

\*D1 can be any LED,  $V_F = 1.5\text{V}$  to  $2.2\text{V}$  at  $3\text{mA}$ . D1 can act as an indicator. D1 is on if  $I_{\text{THRESHOLD}}$  falls below the threshold current, except with  $I = 0$ .

**Figure 8-10. Current Source**

#### 8.2.6.1 Design Requirements

Create 100mA current source.

#### 8.2.6.2 Detailed Design Procedure

$$I_{\text{OUT}} = V_{\text{OUT}} / R_1 \tag{14}$$

where

- $V_{\text{OUT}}$  is the voltage drop across the shunt reference.

In this case,  $I_{\text{OUT}} = 1.24 / R_1$ .

### 8.2.7 LM4041 in Clamp Circuits

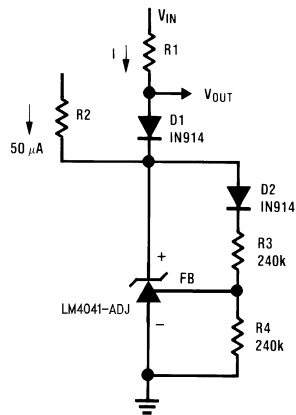

Figure 8-11. Fast Positive Clamp  $2.4V + V_{D1}$

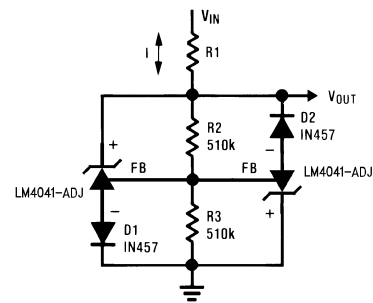

Figure 8-12. Bidirectional Clamp  $\pm 2.4V$

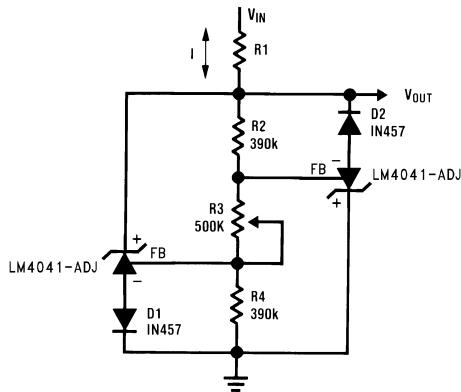

Figure 8-13. Bidirectional Adjustable Clamp  $\pm 18V$  to  $\pm 2.4V$

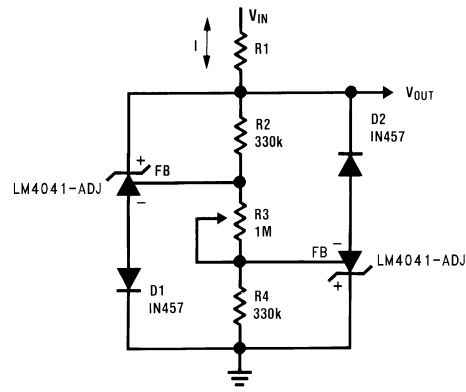

Figure 8-14. Bidirectional Adjustable Clamp  $\pm 2.4V$  to  $\pm 6V$

#### 8.2.7.1 Design Requirements

Create adjustable clamping circuits using the LM4041-N LM4041-N-Q1.

#### 8.2.7.2 Detailed Design Procedure

Use the LM4041-N LM4041-N-Q1 in open-loop, as a 1.24V diode that can be on or off based on the voltage at the feedback. See Figure 8-11 through Figure 8-14 for examples.

### 8.2.8 Floating Current Detector

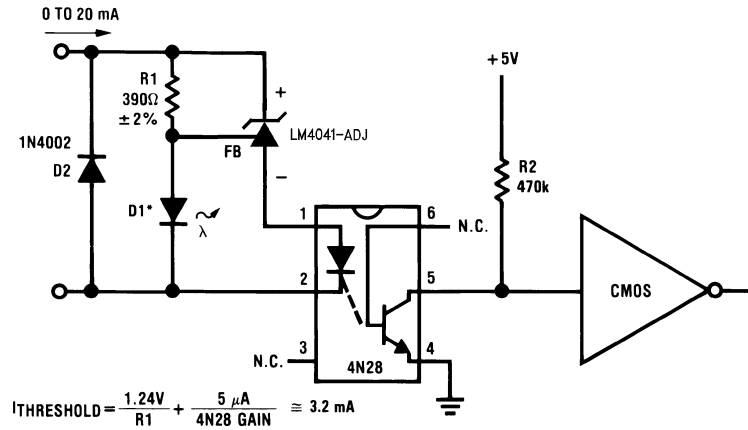

Figure 8-15. Simple Floating Current Detector

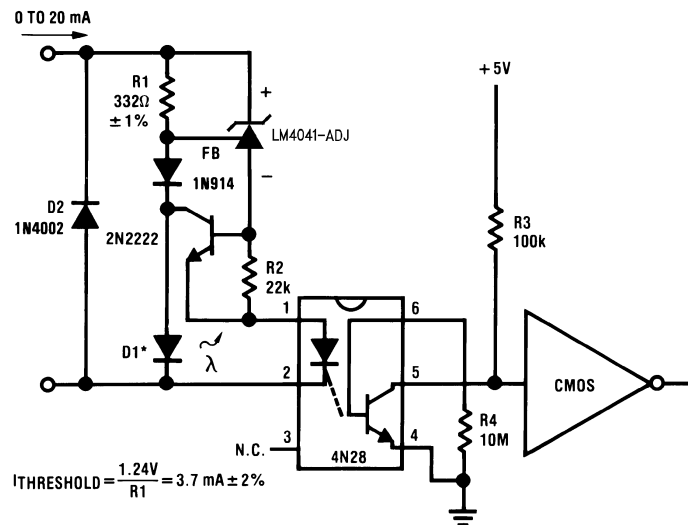

Figure 8-16. Precision Floating Current Detector

#### 8.2.8.1 Design Requirement

Create a floating current detector using the LM4041-N LM4041-N-Q1.

#### 8.2.8.2 Detailed Design Procedure

Use the LM4041-N LM4041-N-Q1 as a voltage dependent diode, which turns on and off based on the voltage drop across R1. See [Figure 8-15](#) and [Figure 8-16](#) for examples.

### 8.3 Power Supply Recommendations

While a bypass capacitor is not required on the input voltage line, TI recommends reducing noise on the input which can affect the output. A 0.1 $\mu$ F ceramic capacitor or larger is recommended.

### 8.4 Layout

#### 8.4.1 Layout Guidelines

Place external components as close to the device as possible. Place  $R_S$  close the cathode, as well as the input bypass capacitor, if used. Keep feedback resistor close the device whenever possible.

#### 8.4.2 Layout Example

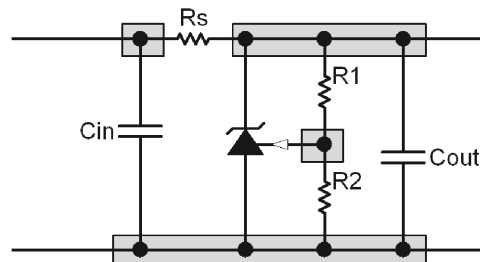

Figure 8-17. Recommended Layout

## 9 Device and Documentation Support

### 9.1 Receiving Notification of Documentation Updates

To receive notification of documentation updates, navigate to the device product folder on [ti.com](http://ti.com). Click on *Notifications* to register and receive a weekly digest of any product information that has changed. For change details, review the revision history included in any revised document.

### 9.2 Support Resources

[TI E2E™ support forums](#) are an engineer's go-to source for fast, verified answers and design help — straight from the experts. Search existing answers or ask your own question to get the quick design help you need.

Linked content is provided "AS IS" by the respective contributors. They do not constitute TI specifications and do not necessarily reflect TI's views; see TI's [Terms of Use](#).

### 9.3 Trademarks

TI E2E™ is a trademark of Texas Instruments.  
All trademarks are the property of their respective owners.

### 9.4 Electrostatic Discharge Caution



This integrated circuit can be damaged by ESD. Texas Instruments recommends that all integrated circuits be handled with appropriate precautions. Failure to observe proper handling and installation procedures can cause damage.

ESD damage can range from subtle performance degradation to complete device failure. Precision integrated circuits may be more susceptible to damage because very small parametric changes could cause the device not to meet its published specifications.

### 9.5 Glossary

[TI Glossary](#) This glossary lists and explains terms, acronyms, and definitions.

## 10 Revision History

NOTE: Page numbers for previous revisions may differ from page numbers in the current version.

<b>Changes from Revision H (March 2025) to Revision I (July 2025)</b>	<b>Page</b>
• Fixed typo regarding the maximum operating current only in the "Description" section.....	1
• Made corrections on labeling errors for reverse breakdown change with current with no specification changes. ....	10

<b>Changes from Revision G (January 2016) to Revision H (March 2025)</b>	<b>Page</b>
• Updated the numbering format for tables, figures, and cross-references throughout the document.....	1
• Updated <i>Applications</i> links.....	1
• Updated LP pin numbering.....	3
• Added electromagnetic interference note and updated LP pinout numbering.....	3
• Removed machine model (MM) ESD specification, updated CDM ESD specification.....	5
• Updated reverse current specification .....	5
• Changed minimum operating current test conditions from: LM4041EEM3, LM4041QEEM3 to: $T_A = T_J = T_{MIN}$ to $T_{MAX}$ .....	10
• Changed VR temperature coefficient test conditions from: LM4041EEM3, LM4041QEEM3 to: $I_R = 10\text{mA}$ ....	10
• Changed VR temperature coefficient test conditions from: LM4041EEM3, LM4041QEEM3 to: $I_R = 100\mu\text{A}$ ...	10
• Added $\Delta V_{REF}/\Delta V_{KA}$ information for adjustable versions.....	23
• Added ordering information for part numbers which include "X".....	32

---

**Changes from Revision F (July 2013) to Revision G (October 2015)** **Page**

- Added *ESD Ratings* table, *Feature Description* section, *Device Functional Modes*, *Application and Implementation* section, *Power Supply Recommendations* section, *Layout* section, *Device and Documentation Support* section, and *Mechanical, Packaging, and Orderable Information* section ..... 1
  - Updated pinout diagrams ..... 3
- 

---

**Changes from Revision D (April 2013) to Revision E (April 2013)** **Page**

- Changed layout of National Data Sheet to TI format.....26
- 

## 11 Mechanical, Packaging, and Orderable Information

The following pages include mechanical, packaging, and orderable information. This information is the most current data available for the designated devices. This data is subject to change without notice and revision of this document. For browser-based versions of this data sheet, refer to the left-hand navigation. Part numbers containing an "X" contain the same electrical properties as those which do not contain an "X".

**PACKAGING INFORMATION**

Orderable part number	Status (1)	Material type (2)	Package   Pins	Package qty   Carrier	RoHS (3)	Lead finish/ Ball material (4)	MSL rating/ Peak reflow (5)	Op temp (°C)	Part marking (6)
LM4041AIM3-1.2/NO.A	Active	Production	SOT-23 (DBZ)   3	3000   SMALL T&R	Yes	NIPDAU	Level-1-260C-UNLIM	-40 to 125	R1A
LM4041AIM3-1.2/NO.B	Active	Production	SOT-23 (DBZ)   3	3000   SMALL T&R	-	Call TI	Call TI	-40 to 125	
<a href="#">LM4041AIM3-1.2/NOPB</a>	Active	Production	SOT-23 (DBZ)   3	3000   SMALL T&R	Yes	NIPDAU   SN	Level-1-260C-UNLIM	-40 to 85	R1A
LM4041AIM3X-1.2/NO.A	Active	Production	SOT-23 (DBZ)   3	3000   LARGE T&R	Yes	NIPDAU	Level-1-260C-UNLIM	-40 to 125	R1A
LM4041AIM3X-1.2/NO.B	Active	Production	SOT-23 (DBZ)   3	3000   LARGE T&R	-	Call TI	Call TI	-40 to 125	
<a href="#">LM4041AIM3X-1.2/NOPB</a>	Active	Production	SOT-23 (DBZ)   3	3000   LARGE T&R	Yes	NIPDAU	Level-1-260C-UNLIM	-40 to 85	R1A
<a href="#">LM4041AIZ-1.2/NOPB</a>	Active	Production	TO-92 (LP)   3	1800   BULK	Yes	Call TI   Sn	N/A for Pkg Type	-40 to 85	4041A IZ1.2
LM4041AIZ-1.2/NOPB.A	Active	Production	TO-92 (LP)   3	1800   BULK	Yes	SN	N/A for Pkg Type	-40 to 85	4041A IZ1.2
LM4041BIM3-1.2/G4	Active	Production	SOT-23 (DBZ)   3	3000   SMALL T&R	Yes	NIPDAU	Level-1-260C-UNLIM	-40 to 125	R1B
LM4041BIM3-1.2/G4.A	Active	Production	SOT-23 (DBZ)   3	3000   SMALL T&R	Yes	NIPDAU	Level-1-260C-UNLIM	-40 to 125	R1B
LM4041BIM3-1.2/NO.A	Active	Production	SOT-23 (DBZ)   3	3000   SMALL T&R	Yes	NIPDAU	Level-1-260C-UNLIM	-40 to 125	R1B
<a href="#">LM4041BIM3-1.2/NOPB</a>	Active	Production	SOT-23 (DBZ)   3	3000   SMALL T&R	Yes	NIPDAU	Level-1-260C-UNLIM	-40 to 85	R1B
LM4041BIM3X-1.2/NO.A	Active	Production	SOT-23 (DBZ)   3	3000   LARGE T&R	Yes	NIPDAU	Level-1-260C-UNLIM	-40 to 125	R1B
LM4041BIM3X-1.2/NO.B	Active	Production	SOT-23 (DBZ)   3	3000   LARGE T&R	-	Call TI	Call TI	-40 to 125	
<a href="#">LM4041BIM3X-1.2/NOPB</a>	Active	Production	SOT-23 (DBZ)   3	3000   LARGE T&R	Yes	NIPDAU	Level-1-260C-UNLIM	-40 to 85	R1B
LM4041BIM7-1.2/NO.A	Active	Production	SC70 (DCK)   5	3000   SMALL T&R	Yes	SN	Level-1-260C-UNLIM	-40 to 125	R1B
<a href="#">LM4041BIM7-1.2/NOPB</a>	Active	Production	SC70 (DCK)   5	3000   SMALL T&R	Yes	SN	Level-1-260C-UNLIM	-40 to 85	R1B
LM4041BIM7X-1.2/NO.A	Active	Production	SC70 (DCK)   5	3000   LARGE T&R	Yes	SN	Level-1-260C-UNLIM	-40 to 125	R1B
<a href="#">LM4041BIM7X-1.2/NOPB</a>	Active	Production	SC70 (DCK)   5	3000   LARGE T&R	Yes	SN	Level-1-260C-UNLIM	-40 to 85	R1B
<a href="#">LM4041BIZ-1.2/NOPB</a>	Active	Production	TO-92 (LP)   3	1800   BULK	Yes	Call TI   Sn	N/A for Pkg Type	-40 to 85	4041B IZ1.2
LM4041BIZ-1.2/NOPB.A	Active	Production	TO-92 (LP)   3	1800   BULK	Yes	SN	N/A for Pkg Type	-40 to 85	4041B IZ1.2
LM4041BIZ-1.2/NOPB.B	Active	Production	TO-92 (LP)   3	1800   BULK	Yes	SN	N/A for Pkg Type	-40 to 85	4041B IZ1.2
LM4041CEM3-1.2/G4	Active	Production	SOT-23 (DBZ)   3	3000   SMALL T&R	Yes	NIPDAU	Level-1-260C-UNLIM	-40 to 125	R1C
LM4041CEM3-1.2/G4.A	Active	Production	SOT-23 (DBZ)   3	3000   SMALL T&R	Yes	NIPDAU	Level-1-260C-UNLIM	-40 to 125	R1C
LM4041CEM3-1.2/NO.A	Active	Production	SOT-23 (DBZ)   3	3000   SMALL T&R	Yes	NIPDAU	Level-1-260C-UNLIM	-40 to 125	R1C

Orderable part number	Status (1)	Material type (2)	Package   Pins	Package qty   Carrier	RoHS (3)	Lead finish/ Ball material (4)	MSL rating/ Peak reflow (5)	Op temp (°C)	Part marking (6)
LM4041CEM3-1.2/NO.B	Active	Production	SOT-23 (DBZ)   3	3000   SMALL T&R	-	Call TI	Call TI	-40 to 125	
<a href="#">LM4041CEM3-1.2/NOPB</a>	Active	Production	SOT-23 (DBZ)   3	3000   SMALL T&R	Yes	NIPDAU	Level-1-260C-UNLIM	-40 to 125	R1C
LM4041CEM3-ADJ/NO.A	Active	Production	SOT-23 (DBZ)   3	3000   SMALL T&R	Yes	SN	Level-1-260C-UNLIM	-40 to 125	RAC
<a href="#">LM4041CEM3-ADJ/NOPB</a>	Active	Production	SOT-23 (DBZ)   3	3000   SMALL T&R	Yes	SN	Level-1-260C-UNLIM	-40 to 125	RAC
LM4041CEM3X-1.2/NO.A	Active	Production	SOT-23 (DBZ)   3	3000   LARGE T&R	Yes	NIPDAU	Level-1-260C-UNLIM	-40 to 125	R1C
<a href="#">LM4041CEM3X-1.2/NOPB</a>	Active	Production	SOT-23 (DBZ)   3	3000   LARGE T&R	Yes	NIPDAU	Level-1-260C-UNLIM	-40 to 125	R1C
LM4041CEM3X-ADJ/NO.A	Active	Production	SOT-23 (DBZ)   3	3000   LARGE T&R	Yes	SN	Level-1-260C-UNLIM	-40 to 125	RAC
<a href="#">LM4041CEM3X-ADJ/NOPB</a>	Active	Production	SOT-23 (DBZ)   3	3000   LARGE T&R	Yes	SN	Level-1-260C-UNLIM	-40 to 125	RAC
LM4041CIM3-1.2/NO.A	Active	Production	SOT-23 (DBZ)   3	3000   SMALL T&R	Yes	NIPDAU	Level-1-260C-UNLIM	-40 to 125	R1C
<a href="#">LM4041CIM3-1.2/NOPB</a>	Active	Production	SOT-23 (DBZ)   3	3000   SMALL T&R	Yes	NIPDAU	Level-1-260C-UNLIM	-40 to 85	R1C
LM4041CIM3-ADJ/NO.A	Active	Production	SOT-23 (DBZ)   3	3000   SMALL T&R	Yes	SN	Level-1-260C-UNLIM	-40 to 125	RAC
<a href="#">LM4041CIM3-ADJ/NOPB</a>	Active	Production	SOT-23 (DBZ)   3	3000   SMALL T&R	Yes	SN	Level-1-260C-UNLIM	-40 to 85	RAC
LM4041CIM3X-1.2/NO.A	Active	Production	SOT-23 (DBZ)   3	3000   LARGE T&R	Yes	NIPDAU	Level-1-260C-UNLIM	-40 to 125	R1C
LM4041CIM3X-1.2/NO.B	Active	Production	SOT-23 (DBZ)   3	3000   LARGE T&R	-	Call TI	Call TI	-40 to 125	
<a href="#">LM4041CIM3X-1.2/NOPB</a>	Active	Production	SOT-23 (DBZ)   3	3000   LARGE T&R	Yes	NIPDAU	Level-1-260C-UNLIM	-40 to 85	R1C
LM4041CIM3X-ADJ/NO.A	Active	Production	SOT-23 (DBZ)   3	3000   LARGE T&R	Yes	SN	Level-1-260C-UNLIM	-40 to 125	RAC
<a href="#">LM4041CIM3X-ADJ/NOPB</a>	Active	Production	SOT-23 (DBZ)   3	3000   LARGE T&R	Yes	SN	Level-1-260C-UNLIM	-40 to 85	RAC
LM4041CIM7-1.2/NO.A	Active	Production	SC70 (DCK)   5	3000   SMALL T&R	Yes	SN	Level-1-260C-UNLIM	-40 to 125	R1C
<a href="#">LM4041CIM7-1.2/NOPB</a>	Active	Production	SC70 (DCK)   5	3000   SMALL T&R	Yes	SN	Level-1-260C-UNLIM	-40 to 85	R1C
LM4041CIM7-ADJ/NO.A	Active	Production	SC70 (DCK)   5	3000   SMALL T&R	Yes	SN	Level-1-260C-UNLIM	-40 to 125	RAC
<a href="#">LM4041CIM7-ADJ/NOPB</a>	Active	Production	SC70 (DCK)   5	3000   SMALL T&R	Yes	SN	Level-1-260C-UNLIM	-40 to 85	RAC
LM4041CIM7X-1.2/NO.A	Active	Production	SC70 (DCK)   5	3000   LARGE T&R	Yes	SN	Level-1-260C-UNLIM	-40 to 125	R1C
<a href="#">LM4041CIM7X-1.2/NOPB</a>	Active	Production	SC70 (DCK)   5	3000   LARGE T&R	Yes	SN	Level-1-260C-UNLIM	-40 to 85	R1C
LM4041CIM7X-ADJ/NO.A	Active	Production	SC70 (DCK)   5	3000   LARGE T&R	Yes	SN	Level-1-260C-UNLIM	-40 to 125	RAC
<a href="#">LM4041CIM7X-ADJ/NOPB</a>	Active	Production	SC70 (DCK)   5	3000   LARGE T&R	Yes	SN	Level-1-260C-UNLIM	-40 to 85	RAC
<a href="#">LM4041CIZ-1.2/NOPB</a>	Active	Production	TO-92 (LP)   3	1800   BULK	Yes	Call TI   Sn	N/A for Pkg Type	-40 to 85	4041C IZ1.2
LM4041CIZ-1.2/NOPB.A	Active	Production	TO-92 (LP)   3	1800   BULK	Yes	SN	N/A for Pkg Type	-40 to 85	4041C IZ1.2
LM4041CIZ-1.2/NOPB.B	Active	Production	TO-92 (LP)   3	1800   BULK	Yes	SN	N/A for Pkg Type	-40 to 85	4041C IZ1.2

Orderable part number	Status (1)	Material type (2)	Package   Pins	Package qty   Carrier	RoHS (3)	Lead finish/ Ball material (4)	MSL rating/ Peak reflow (5)	Op temp (°C)	Part marking (6)
<a href="#">LM4041CIZ-ADJ/NOPB</a>	Active	Production	TO-92 (LP)   3	1800   BULK	Yes	Call TI	N/A for Pkg Type	-40 to 85	4041C IZADJ
LM4041CIZ-ADJ/NOPB.B	Active	Production	TO-92 (LP)   3	1800   BULK	Yes	Call TI	N/A for Pkg Type	-40 to 85	4041C IZADJ
LM4041DEM3-1.2/NO.A	Active	Production	SOT-23 (DBZ)   3	3000   SMALL T&R	Yes	NIPDAU	Level-1-260C-UNLIM	-40 to 125	R1D
<a href="#">LM4041DEM3-1.2/NOPB</a>	Active	Production	SOT-23 (DBZ)   3	3000   SMALL T&R	Yes	NIPDAU	Level-1-260C-UNLIM	-40 to 125	R1D
LM4041DEM3-ADJ/NO.A	Active	Production	SOT-23 (DBZ)   3	3000   SMALL T&R	Yes	SN	Level-1-260C-UNLIM	-40 to 125	RAD
<a href="#">LM4041DEM3-ADJ/NOPB</a>	Active	Production	SOT-23 (DBZ)   3	3000   SMALL T&R	Yes	SN	Level-1-260C-UNLIM	-40 to 125	RAD
LM4041DEM3X-1.2/NO.A	Active	Production	SOT-23 (DBZ)   3	3000   LARGE T&R	Yes	NIPDAU	Level-1-260C-UNLIM	-40 to 125	R1D
<a href="#">LM4041DEM3X-1.2/NOPB</a>	Active	Production	SOT-23 (DBZ)   3	3000   LARGE T&R	Yes	NIPDAU	Level-1-260C-UNLIM	-40 to 125	R1D
LM4041DEM3X-ADJ/NO.A	Active	Production	SOT-23 (DBZ)   3	3000   LARGE T&R	Yes	SN	Level-1-260C-UNLIM	-40 to 125	RAD
<a href="#">LM4041DEM3X-ADJ/NOPB</a>	Active	Production	SOT-23 (DBZ)   3	3000   LARGE T&R	Yes	SN	Level-1-260C-UNLIM	-40 to 125	RAD
LM4041DIM3-1.2/NO.A	Active	Production	SOT-23 (DBZ)   3	3000   SMALL T&R	Yes	NIPDAU	Level-1-260C-UNLIM	-40 to 125	R1D
<a href="#">LM4041DIM3-1.2/NOPB</a>	Active	Production	SOT-23 (DBZ)   3	3000   SMALL T&R	Yes	NIPDAU   SN	Level-1-260C-UNLIM	-40 to 85	R1D
LM4041DIM3-ADJ/NO.A	Active	Production	SOT-23 (DBZ)   3	3000   SMALL T&R	Yes	SN	Level-1-260C-UNLIM	-40 to 125	RAD
<a href="#">LM4041DIM3-ADJ/NOPB</a>	Active	Production	SOT-23 (DBZ)   3	3000   SMALL T&R	Yes	SN	Level-1-260C-UNLIM	-40 to 85	RAD
LM4041DIM3X-1.2/NO.A	Active	Production	SOT-23 (DBZ)   3	3000   LARGE T&R	Yes	NIPDAU	Level-1-260C-UNLIM	-40 to 125	R1D
<a href="#">LM4041DIM3X-1.2/NOPB</a>	Active	Production	SOT-23 (DBZ)   3	3000   LARGE T&R	Yes	NIPDAU	Level-1-260C-UNLIM	-40 to 85	R1D
LM4041DIM3X-ADJ/NO.A	Active	Production	SOT-23 (DBZ)   3	3000   LARGE T&R	Yes	SN	Level-1-260C-UNLIM	-40 to 125	RAD
<a href="#">LM4041DIM3X-ADJ/NOPB</a>	Active	Production	SOT-23 (DBZ)   3	3000   LARGE T&R	Yes	SN	Level-1-260C-UNLIM	-40 to 85	RAD
LM4041DIM7-1.2/NO.A	Active	Production	SC70 (DCK)   5	3000   SMALL T&R	Yes	SN	Level-1-260C-UNLIM	-40 to 125	R1D
<a href="#">LM4041DIM7-1.2/NOPB</a>	Active	Production	SC70 (DCK)   5	3000   SMALL T&R	Yes	SN	Level-1-260C-UNLIM	-40 to 85	R1D
LM4041DIM7-ADJ/NO.A	Active	Production	SC70 (DCK)   5	3000   SMALL T&R	Yes	SN	Level-1-260C-UNLIM	-40 to 125	RAD
<a href="#">LM4041DIM7-ADJ/NOPB</a>	Active	Production	SC70 (DCK)   5	3000   SMALL T&R	Yes	SN	Level-1-260C-UNLIM	-40 to 85	RAD
LM4041DIM7X-1.2/NO.A	Active	Production	SC70 (DCK)   5	3000   LARGE T&R	Yes	SN	Level-1-260C-UNLIM	-40 to 125	R1D
<a href="#">LM4041DIM7X-1.2/NOPB</a>	Active	Production	SC70 (DCK)   5	3000   LARGE T&R	Yes	SN	Level-1-260C-UNLIM	-40 to 85	R1D
LM4041DIM7X-ADJ/NO.A	Active	Production	SC70 (DCK)   5	3000   LARGE T&R	Yes	SN	Level-1-260C-UNLIM	-40 to 125	RAD
<a href="#">LM4041DIM7X-ADJ/NOPB</a>	Active	Production	SC70 (DCK)   5	3000   LARGE T&R	Yes	SN	Level-1-260C-UNLIM	-40 to 85	RAD
<a href="#">LM4041DIZ-1.2/NOPB</a>	Active	Production	TO-92 (LP)   3	1800   BULK	Yes	Call TI   Sn	N/A for Pkg Type	-40 to 85	4041D IZ1.2
LM4041DIZ-1.2/NOPB.A	Active	Production	TO-92 (LP)   3	1800   BULK	Yes	SN	N/A for Pkg Type	-40 to 85	4041D IZ1.2

Orderable part number	Status (1)	Material type (2)	Package   Pins	Package qty   Carrier	RoHS (3)	Lead finish/ Ball material (4)	MSL rating/ Peak reflow (5)	Op temp (°C)	Part marking (6)
LM4041DIZ-1.2/NOPB.B	Active	Production	TO-92 (LP)   3	1800   BULK	Yes	SN	N/A for Pkg Type	-40 to 85	4041D IZ1.2
<a href="#">LM4041DIZ-ADJ/LFT1</a>	Active	Production	TO-92 (LP)   3	2000   LARGE T&R	Yes	SN	N/A for Pkg Type	-	4041D IZADJ
LM4041DIZ-ADJ/LFT1.B	Active	Production	TO-92 (LP)   3	2000   LARGE T&R	Yes	SN	N/A for Pkg Type	-40 to 125	4041D IZADJ
<a href="#">LM4041DIZ-ADJ/NOPB</a>	Active	Production	TO-92 (LP)   3	1800   BULK	Yes	Call TI	N/A for Pkg Type	-40 to 85	4041D IZADJ
LM4041DIZ-ADJ/NOPB.B	Active	Production	TO-92 (LP)   3	1800   BULK	Yes	Call TI	N/A for Pkg Type	-40 to 85	4041D IZADJ
LM4041EEM3-1.2/NO.A	Active	Production	SOT-23 (DBZ)   3	1000   SMALL T&R	Yes	NIPDAU	Level-1-260C-UNLIM	-40 to 125	R1E
<a href="#">LM4041EEM3-1.2/NOPB</a>	Active	Production	SOT-23 (DBZ)   3	1000   SMALL T&R	Yes	NIPDAU	Level-1-260C-UNLIM	-40 to 125	R1E
LM4041EEM3X-1.2/NO.A	Active	Production	SOT-23 (DBZ)   3	3000   LARGE T&R	Yes	NIPDAU	Level-1-260C-UNLIM	-40 to 125	R1E
<a href="#">LM4041EEM3X-1.2/NOPB</a>	Active	Production	SOT-23 (DBZ)   3	3000   LARGE T&R	Yes	NIPDAU	Level-1-260C-UNLIM	-40 to 125	R1E
LM4041EIM3-1.2/NO.A	Active	Production	SOT-23 (DBZ)   3	1000   SMALL T&R	Yes	NIPDAU	Level-1-260C-UNLIM	-40 to 125	R1E
LM4041EIM3-1.2/NO.B	Active	Production	SOT-23 (DBZ)   3	1000   SMALL T&R	-	Call TI	Call TI	-40 to 125	
<a href="#">LM4041EIM3-1.2/NOPB</a>	Active	Production	SOT-23 (DBZ)   3	1000   SMALL T&R	Yes	NIPDAU	Level-1-260C-UNLIM	-40 to 85	R1E
LM4041EIM3X-1.2/NO.A	Active	Production	SOT-23 (DBZ)   3	3000   LARGE T&R	Yes	NIPDAU	Level-1-260C-UNLIM	-40 to 125	R1E
LM4041EIM3X-1.2/NO.B	Active	Production	SOT-23 (DBZ)   3	3000   LARGE T&R	-	Call TI	Call TI	-40 to 125	
<a href="#">LM4041EIM3X-1.2/NOPB</a>	Active	Production	SOT-23 (DBZ)   3	3000   LARGE T&R	Yes	NIPDAU	Level-1-260C-UNLIM	-40 to 85	R1E
LM4041EIM7-1.2/NO.A	Active	Production	SC70 (DCK)   5	3000   SMALL T&R	Yes	SN	Level-1-260C-UNLIM	-40 to 125	R1E
<a href="#">LM4041EIM7-1.2/NOPB</a>	Active	Production	SC70 (DCK)   5	3000   SMALL T&R	Yes	SN	Level-1-260C-UNLIM	-40 to 85	R1E
LM4041EIM7X-1.2/NO.A	Active	Production	SC70 (DCK)   5	3000   LARGE T&R	Yes	SN	Level-1-260C-UNLIM	-40 to 125	R1E
<a href="#">LM4041EIM7X-1.2/NOPB</a>	Active	Production	SC70 (DCK)   5	3000   LARGE T&R	Yes	SN	Level-1-260C-UNLIM	-40 to 85	R1E
<a href="#">LM4041QAIM3-1.2/NO</a>	Active	Production	SOT-23 (DBZ)   3	3000   LARGE T&R	Yes	SN	Level-1-260C-UNLIM	-40 to 85	RQA
LM4041QAIM3-1.2/NO.A	Active	Production	SOT-23 (DBZ)   3	3000   LARGE T&R	Yes	SN	Level-1-260C-UNLIM	-40 to 85	RQA
LM4041QAIM3-1.2/NO.B	Active	Production	SOT-23 (DBZ)   3	3000   LARGE T&R	Yes	SN	Level-1-260C-UNLIM	-40 to 85	RQA
<a href="#">LM4041QBIM3-1.2/NO</a>	Active	Production	SOT-23 (DBZ)   3	3000   LARGE T&R	Yes	SN	Level-1-260C-UNLIM	-40 to 85	RQB
LM4041QBIM3-1.2/NO.A	Active	Production	SOT-23 (DBZ)   3	3000   LARGE T&R	Yes	SN	Level-1-260C-UNLIM	-40 to 85	RQB
LM4041QBIM3-1.2/NO.B	Active	Production	SOT-23 (DBZ)   3	3000   LARGE T&R	Yes	SN	Level-1-260C-UNLIM	-40 to 85	RQB
<a href="#">LM4041QCEM3-1.2NO</a>	Active	Production	SOT-23 (DBZ)   3	3000   SMALL T&R	Yes	SN	Level-1-260C-UNLIM	-40 to 125	RQC
LM4041QCEM3-1.2NO.A	Active	Production	SOT-23 (DBZ)   3	3000   SMALL T&R	Yes	SN	Level-1-260C-UNLIM	-40 to 125	RQC

Orderable part number	Status (1)	Material type (2)	Package   Pins	Package qty   Carrier	RoHS (3)	Lead finish/ Ball material (4)	MSL rating/ Peak reflow (5)	Op temp (°C)	Part marking (6)
LM4041QCEM3-1.2NO.B	Active	Production	SOT-23 (DBZ)   3	3000   SMALL T&R	Yes	SN	Level-1-260C-UNLIM	-40 to 125	RQC
<a href="#">LM4041QCEM3-ADJ/NO</a>	Active	Production	SOT-23 (DBZ)   3	3000   LARGE T&R	Yes	SN	Level-1-260C-UNLIM	-40 to 125	RZC
LM4041QCEM3-ADJ/NO.A	Active	Production	SOT-23 (DBZ)   3	3000   LARGE T&R	Yes	SN	Level-1-260C-UNLIM	-40 to 125	RZC
LM4041QCEM3-ADJ/NO.B	Active	Production	SOT-23 (DBZ)   3	3000   LARGE T&R	Yes	SN	Level-1-260C-UNLIM	-40 to 125	RZC
<a href="#">LM4041QCEM3X-1.2NO</a>	Active	Production	SOT-23 (DBZ)   3	3000   LARGE T&R	Yes	SN	Level-1-260C-UNLIM	-40 to 125	RQC
LM4041QCEM3X-1.2NO.A	Active	Production	SOT-23 (DBZ)   3	3000   LARGE T&R	Yes	SN	Level-1-260C-UNLIM	-40 to 125	RQC
LM4041QCEM3X-1.2NO.B	Active	Production	SOT-23 (DBZ)   3	3000   LARGE T&R	Yes	SN	Level-1-260C-UNLIM	-40 to 125	RQC
<a href="#">LM4041QCIM3-1.2/NO</a>	Active	Production	SOT-23 (DBZ)   3	3000   LARGE T&R	Yes	SN	Level-1-260C-UNLIM	-40 to 85	RQC
LM4041QCIM3-1.2/NO.A	Active	Production	SOT-23 (DBZ)   3	3000   LARGE T&R	Yes	SN	Level-1-260C-UNLIM	-40 to 85	RQC
LM4041QCIM3-1.2/NO.B	Active	Production	SOT-23 (DBZ)   3	3000   LARGE T&R	Yes	SN	Level-1-260C-UNLIM	-40 to 85	RQC
<a href="#">LM4041QCIM3-ADJ/NO</a>	Active	Production	SOT-23 (DBZ)   3	3000   LARGE T&R	Yes	SN	Level-1-260C-UNLIM	-40 to 85	RZC
LM4041QCIM3-ADJ/NO.A	Active	Production	SOT-23 (DBZ)   3	3000   LARGE T&R	Yes	SN	Level-1-260C-UNLIM	-40 to 85	RZC
LM4041QCIM3-ADJ/NO.B	Active	Production	SOT-23 (DBZ)   3	3000   LARGE T&R	Yes	SN	Level-1-260C-UNLIM	-40 to 85	RZC
<a href="#">LM4041QDEM3-1.2/NO</a>	Active	Production	SOT-23 (DBZ)   3	3000   LARGE T&R	Yes	SN	Level-1-260C-UNLIM	-40 to 125	RQD
LM4041QDEM3-1.2/NO.A	Active	Production	SOT-23 (DBZ)   3	3000   LARGE T&R	Yes	SN	Level-1-260C-UNLIM	-40 to 125	RQD
LM4041QDEM3-1.2/NO.B	Active	Production	SOT-23 (DBZ)   3	3000   LARGE T&R	Yes	SN	Level-1-260C-UNLIM	-40 to 125	RQD
<a href="#">LM4041QDEM3-ADJ/NO</a>	Active	Production	SOT-23 (DBZ)   3	3000   LARGE T&R	Yes	SN	Level-1-260C-UNLIM	-40 to 125	RZD
LM4041QDEM3-ADJ/NO.A	Active	Production	SOT-23 (DBZ)   3	3000   LARGE T&R	Yes	SN	Level-1-260C-UNLIM	-40 to 125	RZD
LM4041QDEM3-ADJ/NO.B	Active	Production	SOT-23 (DBZ)   3	3000   LARGE T&R	Yes	SN	Level-1-260C-UNLIM	-40 to 125	RZD
<a href="#">LM4041QDIM3-1.2/NO</a>	Active	Production	SOT-23 (DBZ)   3	3000   LARGE T&R	Yes	SN	Level-1-260C-UNLIM	-40 to 85	RQD
LM4041QDIM3-1.2/NO.A	Active	Production	SOT-23 (DBZ)   3	3000   LARGE T&R	Yes	SN	Level-1-260C-UNLIM	-40 to 85	RQD
LM4041QDIM3-1.2/NO.B	Active	Production	SOT-23 (DBZ)   3	3000   LARGE T&R	Yes	SN	Level-1-260C-UNLIM	-40 to 85	RQD
<a href="#">LM4041QDIM3-ADJ/NO</a>	Active	Production	SOT-23 (DBZ)   3	3000   LARGE T&R	Yes	SN	Level-1-260C-UNLIM	-40 to 85	RZD
LM4041QDIM3-ADJ/NO.A	Active	Production	SOT-23 (DBZ)   3	3000   LARGE T&R	Yes	SN	Level-1-260C-UNLIM	-40 to 85	RZD
LM4041QDIM3-ADJ/NO.B	Active	Production	SOT-23 (DBZ)   3	3000   LARGE T&R	Yes	SN	Level-1-260C-UNLIM	-40 to 85	RZD
<a href="#">LM4041QEEM3-1.2/NO</a>	Active	Production	SOT-23 (DBZ)   3	3000   LARGE T&R	Yes	SN	Level-1-260C-UNLIM	-40 to 125	RQE
LM4041QEEM3-1.2/NO.A	Active	Production	SOT-23 (DBZ)   3	3000   LARGE T&R	Yes	SN	Level-1-260C-UNLIM	-40 to 125	RQE
LM4041QEEM3-1.2/NO.B	Active	Production	SOT-23 (DBZ)   3	3000   LARGE T&R	Yes	SN	Level-1-260C-UNLIM	-40 to 125	RQE
<a href="#">LM4041QEEM3X-1.2NO</a>	Active	Production	SOT-23 (DBZ)   3	3000   LARGE T&R	Yes	SN	Level-1-260C-UNLIM	-40 to 125	RQE
LM4041QEEM3X-1.2NO.A	Active	Production	SOT-23 (DBZ)   3	3000   LARGE T&R	Yes	SN	Level-1-260C-UNLIM	-40 to 125	RQE
LM4041QEEM3X-1.2NO.B	Active	Production	SOT-23 (DBZ)   3	3000   LARGE T&R	Yes	SN	Level-1-260C-UNLIM	-40 to 125	RQE

Orderable part number	Status (1)	Material type (2)	Package   Pins	Package qty   Carrier	RoHS (3)	Lead finish/ Ball material (4)	MSL rating/ Peak reflow (5)	Op temp (°C)	Part marking (6)
LM4041QEIM3-1.2/NO	Active	Production	SOT-23 (DBZ)   3	3000   LARGE T&R	Yes	SN	Level-1-260C-UNLIM	-40 to 85	RQE
LM4041QEIM3-1.2/NO.A	Active	Production	SOT-23 (DBZ)   3	3000   LARGE T&R	Yes	SN	Level-1-260C-UNLIM	-40 to 85	RQE
LM4041QEIM3-1.2/NO.B	Active	Production	SOT-23 (DBZ)   3	3000   LARGE T&R	Yes	SN	Level-1-260C-UNLIM	-40 to 85	RQE

(1) **Status:** For more details on status, see our [product life cycle](#).

(2) **Material type:** When designated, preproduction parts are prototypes/experimental devices, and are not yet approved or released for full production. Testing and final process, including without limitation quality assurance, reliability performance testing, and/or process qualification, may not yet be complete, and this item is subject to further changes or possible discontinuation. If available for ordering, purchases will be subject to an additional waiver at checkout, and are intended for early internal evaluation purposes only. These items are sold without warranties of any kind.

(3) **RoHS values:** Yes, No, RoHS Exempt. See the [TI RoHS Statement](#) for additional information and value definition.

(4) **Lead finish/Ball material:** Parts may have multiple material finish options. Finish options are separated by a vertical ruled line. Lead finish/Ball material values may wrap to two lines if the finish value exceeds the maximum column width.

(5) **MSL rating/Peak reflow:** The moisture sensitivity level ratings and peak solder (reflow) temperatures. In the event that a part has multiple moisture sensitivity ratings, only the lowest level per JEDEC standards is shown. Refer to the shipping label for the actual reflow temperature that will be used to mount the part to the printed circuit board.

(6) **Part marking:** There may be an additional marking, which relates to the logo, the lot trace code information, or the environmental category of the part.

Multiple part markings will be inside parentheses. Only one part marking contained in parentheses and separated by a "-" will appear on a part. If a line is indented then it is a continuation of the previous line and the two combined represent the entire part marking for that device.

**Important Information and Disclaimer:** The information provided on this page represents TI's knowledge and belief as of the date that it is provided. TI bases its knowledge and belief on information provided by third parties, and makes no representation or warranty as to the accuracy of such information. Efforts are underway to better integrate information from third parties. TI has taken and continues to take reasonable steps to provide representative and accurate information but may not have conducted destructive testing or chemical analysis on incoming materials and chemicals. TI and TI suppliers consider certain information to be proprietary, and thus CAS numbers and other limited information may not be available for release.

In no event shall TI's liability arising out of such information exceed the total purchase price of the TI part(s) at issue in this document sold by TI to Customer on an annual basis.

**OTHER QUALIFIED VERSIONS OF LM4041-N, LM4041-N-Q1 :**

● Catalog : [LM4041-N](#)

● Automotive : [LM4041-N-Q1](#)

**NOTE: Qualified Version Definitions:**

- Catalog - TI's standard catalog product
- Automotive - Q100 devices qualified for high-reliability automotive applications targeting zero defects

**TAPE AND REEL INFORMATION**

**QUADRANT ASSIGNMENTS FOR PIN 1 ORIENTATION IN TAPE**

\*All dimensions are nominal

Device	Package Type	Package Drawing	Pins	SPQ	Reel Diameter (mm)	Reel Width W1 (mm)	A0 (mm)	B0 (mm)	K0 (mm)	P1 (mm)	W (mm)	Pin1 Quadrant
LM4041AIM3-1.2/NOPB	SOT-23	DBZ	3	3000	180.0	8.4	2.9	3.35	1.35	4.0	8.0	Q3
LM4041AIM3X-1.2/NOPB	SOT-23	DBZ	3	3000	180.0	8.4	2.9	3.35	1.35	4.0	8.0	Q3
LM4041BIM3-1.2/G4	SOT-23	DBZ	3	3000	180.0	8.4	2.9	3.35	1.35	4.0	8.0	Q3
LM4041BIM3-1.2/NOPB	SOT-23	DBZ	3	3000	180.0	8.4	2.9	3.35	1.35	4.0	8.0	Q3
LM4041BIM3X-1.2/NOPB	SOT-23	DBZ	3	3000	180.0	8.4	2.9	3.35	1.35	4.0	8.0	Q3
LM4041BIM7-1.2/NOPB	SC70	DCK	5	3000	180.0	8.4	2.3	2.5	1.2	4.0	8.0	Q3
LM4041BIM7-1.2/NOPB	SC70	DCK	5	3000	178.0	8.4	2.25	2.45	1.2	4.0	8.0	Q3
LM4041BIM7X-1.2/NOPB	SC70	DCK	5	3000	178.0	8.4	2.25	2.45	1.2	4.0	8.0	Q3
LM4041BIM7X-1.2/NOPB	SC70	DCK	5	3000	180.0	8.4	2.3	2.5	1.2	4.0	8.0	Q3
LM4041CEM3-1.2/G4	SOT-23	DBZ	3	3000	180.0	8.4	2.9	3.35	1.35	4.0	8.0	Q3
LM4041CEM3-1.2/NOPB	SOT-23	DBZ	3	3000	180.0	8.4	2.9	3.35	1.35	4.0	8.0	Q3
LM4041CEM3-ADJ/NOPB	SOT-23	DBZ	3	3000	178.0	8.4	3.3	2.9	1.22	4.0	8.0	Q3
LM4041CEM3X-1.2/NOPB	SOT-23	DBZ	3	3000	180.0	8.4	2.9	3.35	1.35	4.0	8.0	Q3
LM4041CEM3X-ADJ/NOPB	SOT-23	DBZ	3	3000	178.0	8.4	3.3	2.9	1.22	4.0	8.0	Q3
LM4041CIM3-1.2/NOPB	SOT-23	DBZ	3	3000	180.0	8.4	2.9	3.35	1.35	4.0	8.0	Q3

Device	Package Type	Package Drawing	Pins	SPQ	Reel Diameter (mm)	Reel Width W1 (mm)	A0 (mm)	B0 (mm)	K0 (mm)	P1 (mm)	W (mm)	Pin1 Quadrant
LM4041CIM3-ADJ/NOPB	SOT-23	DBZ	3	3000	178.0	8.4	3.3	2.9	1.22	4.0	8.0	Q3
LM4041CIM3X-1.2/NOPB	SOT-23	DBZ	3	3000	180.0	8.4	2.9	3.35	1.35	4.0	8.0	Q3
LM4041CIM3X-ADJ/NOPB	SOT-23	DBZ	3	3000	178.0	8.4	3.3	2.9	1.22	4.0	8.0	Q3
LM4041CIM7-1.2/NOPB	SC70	DCK	5	3000	178.0	8.4	2.25	2.45	1.2	4.0	8.0	Q3
LM4041CIM7-1.2/NOPB	SC70	DCK	5	3000	180.0	8.4	2.3	2.5	1.2	4.0	8.0	Q3
LM4041CIM7-ADJ/NOPB	SC70	DCK	5	3000	178.0	8.4	2.25	2.45	1.2	4.0	8.0	Q3
LM4041CIM7X-1.2/NOPB	SC70	DCK	5	3000	178.0	8.4	2.25	2.45	1.2	4.0	8.0	Q3
LM4041CIM7X-1.2/NOPB	SC70	DCK	5	3000	180.0	8.4	2.3	2.5	1.2	4.0	8.0	Q3
LM4041CIM7X-ADJ/NOPB	SC70	DCK	5	3000	178.0	8.4	2.25	2.45	1.2	4.0	8.0	Q3
LM4041DEM3-1.2/NOPB	SOT-23	DBZ	3	3000	180.0	8.4	2.9	3.35	1.35	4.0	8.0	Q3
LM4041DEM3-ADJ/NOPB	SOT-23	DBZ	3	3000	178.0	8.4	3.3	2.9	1.22	4.0	8.0	Q3
LM4041DEM3X-1.2/NOPB	SOT-23	DBZ	3	3000	180.0	8.4	2.9	3.35	1.35	4.0	8.0	Q3
LM4041DEM3X-ADJ/NOPB	SOT-23	DBZ	3	3000	178.0	8.4	3.3	2.9	1.22	4.0	8.0	Q3
LM4041DIM3-1.2/NOPB	SOT-23	DBZ	3	3000	180.0	8.4	2.9	3.35	1.35	4.0	8.0	Q3
LM4041DIM3-ADJ/NOPB	SOT-23	DBZ	3	3000	178.0	8.4	3.3	2.9	1.22	4.0	8.0	Q3
LM4041DIM3X-1.2/NOPB	SOT-23	DBZ	3	3000	180.0	8.4	2.9	3.35	1.35	4.0	8.0	Q3
LM4041DIM3X-ADJ/NOPB	SOT-23	DBZ	3	3000	178.0	8.4	3.3	2.9	1.22	4.0	8.0	Q3
LM4041DIM7-1.2/NOPB	SC70	DCK	5	3000	178.0	8.4	2.25	2.45	1.2	4.0	8.0	Q3
LM4041DIM7-1.2/NOPB	SC70	DCK	5	3000	180.0	8.4	2.3	2.5	1.2	4.0	8.0	Q3
LM4041DIM7-ADJ/NOPB	SC70	DCK	5	3000	178.0	8.4	2.25	2.45	1.2	4.0	8.0	Q3
LM4041DIM7X-1.2/NOPB	SC70	DCK	5	3000	180.0	8.4	2.3	2.5	1.2	4.0	8.0	Q3
LM4041DIM7X-1.2/NOPB	SC70	DCK	5	3000	178.0	8.4	2.25	2.45	1.2	4.0	8.0	Q3
LM4041DIM7X-ADJ/NOPB	SC70	DCK	5	3000	178.0	8.4	2.25	2.45	1.2	4.0	8.0	Q3
LM4041EEM3-1.2/NOPB	SOT-23	DBZ	3	1000	180.0	8.4	2.9	3.35	1.35	4.0	8.0	Q3
LM4041EEM3X-1.2/NOPB	SOT-23	DBZ	3	3000	180.0	8.4	2.9	3.35	1.35	4.0	8.0	Q3
LM4041EIM3-1.2/NOPB	SOT-23	DBZ	3	1000	180.0	8.4	2.9	3.35	1.35	4.0	8.0	Q3
LM4041EIM3X-1.2/NOPB	SOT-23	DBZ	3	3000	180.0	8.4	2.9	3.35	1.35	4.0	8.0	Q3
LM4041EIM7-1.2/NOPB	SC70	DCK	5	3000	178.0	8.4	2.25	2.45	1.2	4.0	8.0	Q3
LM4041EIM7-1.2/NOPB	SC70	DCK	5	3000	180.0	8.4	2.3	2.5	1.2	4.0	8.0	Q3
LM4041EIM7X-1.2/NOPB	SC70	DCK	5	3000	180.0	8.4	2.3	2.5	1.2	4.0	8.0	Q3
LM4041EIM7X-1.2/NOPB	SC70	DCK	5	3000	178.0	8.4	2.25	2.45	1.2	4.0	8.0	Q3
LM4041QAIM3-1.2/NO	SOT-23	DBZ	3	3000	178.0	8.4	3.3	2.9	1.22	4.0	8.0	Q3
LM4041QAIM3-1.2/NO	SOT-23	DBZ	3	3000	180.0	8.4	3.2	2.85	1.3	4.0	8.0	Q3
LM4041QBIM3-1.2/NO	SOT-23	DBZ	3	3000	178.0	8.4	3.3	2.9	1.22	4.0	8.0	Q3
LM4041QBIM3-1.2/NO	SOT-23	DBZ	3	3000	180.0	8.4	3.2	2.85	1.3	4.0	8.0	Q3
LM4041QCEM3-1.2NO	SOT-23	DBZ	3	3000	180.0	8.4	3.2	2.85	1.3	4.0	8.0	Q3
LM4041QCEM3-1.2NO	SOT-23	DBZ	3	3000	178.0	8.4	3.3	2.9	1.22	4.0	8.0	Q3
LM4041QCEM3-ADJ/NO	SOT-23	DBZ	3	3000	178.0	8.4	3.3	2.9	1.22	4.0	8.0	Q3

Device	Package Type	Package Drawing	Pins	SPQ	Reel Diameter (mm)	Reel Width W1 (mm)	A0 (mm)	B0 (mm)	K0 (mm)	P1 (mm)	W (mm)	Pin1 Quadrant
LM4041QCEM3X-1.2NO	SOT-23	DBZ	3	3000	178.0	8.4	3.3	2.9	1.22	4.0	8.0	Q3
LM4041QCEM3X-1.2NO	SOT-23	DBZ	3	3000	180.0	8.4	3.2	2.85	1.3	4.0	8.0	Q3
LM4041QCIM3-1.2/NO	SOT-23	DBZ	3	3000	178.0	8.4	3.3	2.9	1.22	4.0	8.0	Q3
LM4041QCIM3-1.2/NO	SOT-23	DBZ	3	3000	180.0	8.4	3.2	2.85	1.3	4.0	8.0	Q3
LM4041QCIM3-ADJ/NO	SOT-23	DBZ	3	3000	178.0	8.4	3.3	2.9	1.22	4.0	8.0	Q3
LM4041QDEM3-1.2/NO	SOT-23	DBZ	3	3000	180.0	8.4	3.2	2.85	1.3	4.0	8.0	Q3
LM4041QDEM3-1.2/NO	SOT-23	DBZ	3	3000	178.0	8.4	3.3	2.9	1.22	4.0	8.0	Q3
LM4041QDEM3-ADJ/NO	SOT-23	DBZ	3	3000	178.0	8.4	3.3	2.9	1.22	4.0	8.0	Q3
LM4041QDIM3-1.2/NO	SOT-23	DBZ	3	3000	180.0	8.4	3.2	2.85	1.3	4.0	8.0	Q3
LM4041QDIM3-1.2/NO	SOT-23	DBZ	3	3000	178.0	8.4	3.3	2.9	1.22	4.0	8.0	Q3
LM4041QDIM3-ADJ/NO	SOT-23	DBZ	3	3000	178.0	8.4	3.3	2.9	1.22	4.0	8.0	Q3
LM4041QEEM3-1.2/NO	SOT-23	DBZ	3	3000	178.0	8.4	3.3	2.9	1.22	4.0	8.0	Q3
LM4041QEEM3-1.2/NO	SOT-23	DBZ	3	3000	180.0	8.4	3.2	2.85	1.3	4.0	8.0	Q3
LM4041QEEM3X-1.2NO	SOT-23	DBZ	3	3000	178.0	8.4	3.3	2.9	1.22	4.0	8.0	Q3
LM4041QEEM3X-1.2NO	SOT-23	DBZ	3	3000	180.0	8.4	3.2	2.85	1.3	4.0	8.0	Q3
LM4041QEIM3-1.2/NO	SOT-23	DBZ	3	3000	178.0	8.4	3.3	2.9	1.22	4.0	8.0	Q3
LM4041QEIM3-1.2/NO	SOT-23	DBZ	3	3000	180.0	8.4	3.2	2.85	1.3	4.0	8.0	Q3

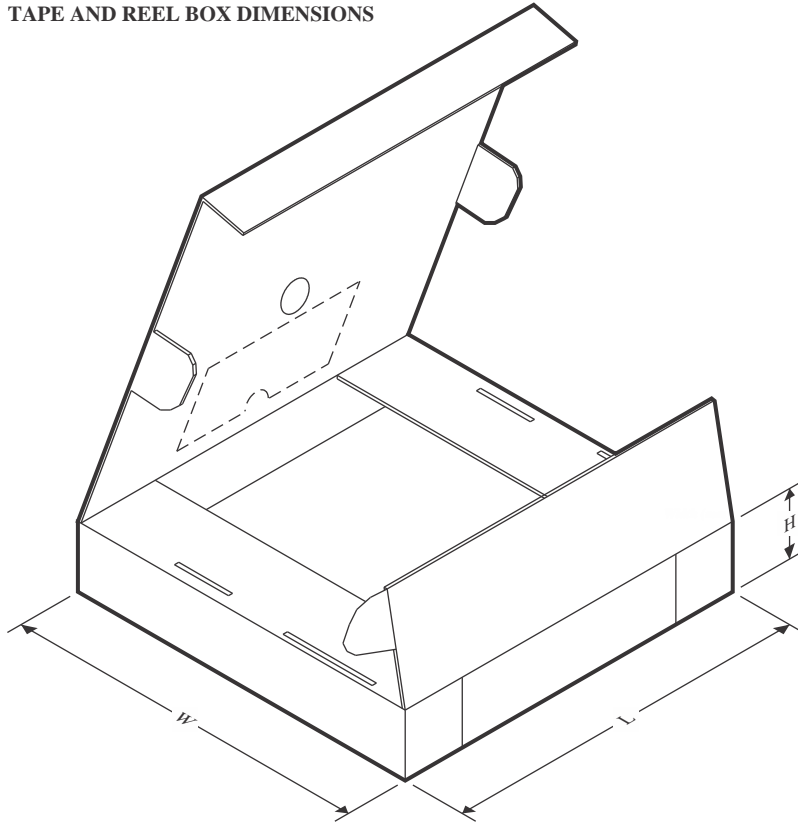
**TAPE AND REEL BOX DIMENSIONS**

\*All dimensions are nominal

Device	Package Type	Package Drawing	Pins	SPQ	Length (mm)	Width (mm)	Height (mm)
LM4041AIM3-1.2/NOPB	SOT-23	DBZ	3	3000	210.0	185.0	35.0
LM4041AIM3X-1.2/NOPB	SOT-23	DBZ	3	3000	210.0	185.0	35.0
LM4041BIM3-1.2/G4	SOT-23	DBZ	3	3000	210.0	185.0	35.0
LM4041BIM3-1.2/NOPB	SOT-23	DBZ	3	3000	210.0	185.0	35.0
LM4041BIM3X-1.2/NOPB	SOT-23	DBZ	3	3000	210.0	185.0	35.0
LM4041BIM7-1.2/NOPB	SC70	DCK	5	3000	210.0	185.0	35.0
LM4041BIM7-1.2/NOPB	SC70	DCK	5	3000	208.0	191.0	35.0
LM4041BIM7X-1.2/NOPB	SC70	DCK	5	3000	208.0	191.0	35.0
LM4041BIM7X-1.2/NOPB	SC70	DCK	5	3000	210.0	185.0	35.0
LM4041CEM3-1.2/G4	SOT-23	DBZ	3	3000	210.0	185.0	35.0
LM4041CEM3-1.2/NOPB	SOT-23	DBZ	3	3000	210.0	185.0	35.0
LM4041CEM3-ADJ/NOPB	SOT-23	DBZ	3	3000	208.0	191.0	35.0
LM4041CEM3X-1.2/NOPB	SOT-23	DBZ	3	3000	210.0	185.0	35.0
LM4041CEM3X-ADJ/NOPB	SOT-23	DBZ	3	3000	208.0	191.0	35.0
LM4041CIM3-1.2/NOPB	SOT-23	DBZ	3	3000	210.0	185.0	35.0
LM4041CIM3-ADJ/NOPB	SOT-23	DBZ	3	3000	208.0	191.0	35.0
LM4041CIM3X-1.2/NOPB	SOT-23	DBZ	3	3000	210.0	185.0	35.0

Device	Package Type	Package Drawing	Pins	SPQ	Length (mm)	Width (mm)	Height (mm)
LM4041CIM3X-ADJ/NOPB	SOT-23	DBZ	3	3000	208.0	191.0	35.0
LM4041CIM7-1.2/NOPB	SC70	DCK	5	3000	208.0	191.0	35.0
LM4041CIM7-1.2/NOPB	SC70	DCK	5	3000	210.0	185.0	35.0
LM4041CIM7-ADJ/NOPB	SC70	DCK	5	3000	208.0	191.0	35.0
LM4041CIM7X-1.2/NOPB	SC70	DCK	5	3000	208.0	191.0	35.0
LM4041CIM7X-1.2/NOPB	SC70	DCK	5	3000	210.0	185.0	35.0
LM4041CIM7X-ADJ/NOPB	SC70	DCK	5	3000	208.0	191.0	35.0
LM4041DEM3-1.2/NOPB	SOT-23	DBZ	3	3000	210.0	185.0	35.0
LM4041DEM3-ADJ/NOPB	SOT-23	DBZ	3	3000	208.0	191.0	35.0
LM4041DEM3X-1.2/NOPB	SOT-23	DBZ	3	3000	210.0	185.0	35.0
LM4041DEM3X-ADJ/NOPB	SOT-23	DBZ	3	3000	208.0	191.0	35.0
LM4041DIM3-1.2/NOPB	SOT-23	DBZ	3	3000	210.0	185.0	35.0
LM4041DIM3-ADJ/NOPB	SOT-23	DBZ	3	3000	208.0	191.0	35.0
LM4041DIM3X-1.2/NOPB	SOT-23	DBZ	3	3000	210.0	185.0	35.0
LM4041DIM3X-ADJ/NOPB	SOT-23	DBZ	3	3000	208.0	191.0	35.0
LM4041DIM7-1.2/NOPB	SC70	DCK	5	3000	208.0	191.0	35.0
LM4041DIM7-1.2/NOPB	SC70	DCK	5	3000	210.0	185.0	35.0
LM4041DIM7-ADJ/NOPB	SC70	DCK	5	3000	208.0	191.0	35.0
LM4041DIM7X-1.2/NOPB	SC70	DCK	5	3000	210.0	185.0	35.0
LM4041DIM7X-1.2/NOPB	SC70	DCK	5	3000	208.0	191.0	35.0
LM4041DIM7X-ADJ/NOPB	SC70	DCK	5	3000	208.0	191.0	35.0
LM4041EEM3-1.2/NOPB	SOT-23	DBZ	3	1000	210.0	185.0	35.0
LM4041EEM3X-1.2/NOPB	SOT-23	DBZ	3	3000	210.0	185.0	35.0
LM4041EIM3-1.2/NOPB	SOT-23	DBZ	3	1000	210.0	185.0	35.0
LM4041EIM3X-1.2/NOPB	SOT-23	DBZ	3	3000	210.0	185.0	35.0
LM4041EIM7-1.2/NOPB	SC70	DCK	5	3000	208.0	191.0	35.0
LM4041EIM7-1.2/NOPB	SC70	DCK	5	3000	210.0	185.0	35.0
LM4041EIM7X-1.2/NOPB	SC70	DCK	5	3000	210.0	185.0	35.0
LM4041EIM7X-1.2/NOPB	SC70	DCK	5	3000	208.0	191.0	35.0
LM4041QAIM3-1.2/NO	SOT-23	DBZ	3	3000	208.0	191.0	35.0
LM4041QAIM3-1.2/NO	SOT-23	DBZ	3	3000	210.0	185.0	35.0
LM4041QBIM3-1.2/NO	SOT-23	DBZ	3	3000	208.0	191.0	35.0
LM4041QBIM3-1.2/NO	SOT-23	DBZ	3	3000	210.0	185.0	35.0
LM4041QCEM3-1.2NO	SOT-23	DBZ	3	3000	210.0	185.0	35.0
LM4041QCEM3-1.2NO	SOT-23	DBZ	3	3000	208.0	191.0	35.0
LM4041QCEM3-ADJ/NO	SOT-23	DBZ	3	3000	208.0	191.0	35.0
LM4041QCEM3X-1.2NO	SOT-23	DBZ	3	3000	208.0	191.0	35.0
LM4041QCEM3X-1.2NO	SOT-23	DBZ	3	3000	210.0	185.0	35.0
LM4041QCIM3-1.2/NO	SOT-23	DBZ	3	3000	208.0	191.0	35.0
LM4041QCIM3-1.2/NO	SOT-23	DBZ	3	3000	210.0	185.0	35.0
LM4041QCIM3-ADJ/NO	SOT-23	DBZ	3	3000	208.0	191.0	35.0
LM4041QDEM3-1.2/NO	SOT-23	DBZ	3	3000	210.0	185.0	35.0

Device	Package Type	Package Drawing	Pins	SPQ	Length (mm)	Width (mm)	Height (mm)
LM4041QDEM3-1.2/NO	SOT-23	DBZ	3	3000	208.0	191.0	35.0
LM4041QDEM3-ADJ/NO	SOT-23	DBZ	3	3000	208.0	191.0	35.0
LM4041QDIM3-1.2/NO	SOT-23	DBZ	3	3000	210.0	185.0	35.0
LM4041QDIM3-1.2/NO	SOT-23	DBZ	3	3000	208.0	191.0	35.0
LM4041QDIM3-ADJ/NO	SOT-23	DBZ	3	3000	208.0	191.0	35.0
LM4041QEEM3-1.2/NO	SOT-23	DBZ	3	3000	208.0	191.0	35.0
LM4041QEEM3-1.2/NO	SOT-23	DBZ	3	3000	210.0	185.0	35.0
LM4041QEEM3X-1.2NO	SOT-23	DBZ	3	3000	208.0	191.0	35.0
LM4041QEEM3X-1.2NO	SOT-23	DBZ	3	3000	210.0	185.0	35.0
LM4041QEIM3-1.2/NO	SOT-23	DBZ	3	3000	208.0	191.0	35.0
LM4041QEIM3-1.2/NO	SOT-23	DBZ	3	3000	210.0	185.0	35.0



# EXAMPLE BOARD LAYOUT

DBZ0003A

SOT-23 - 1.12 mm max height

SMALL OUTLINE TRANSISTOR



LAND PATTERN EXAMPLE  
SCALE:15X

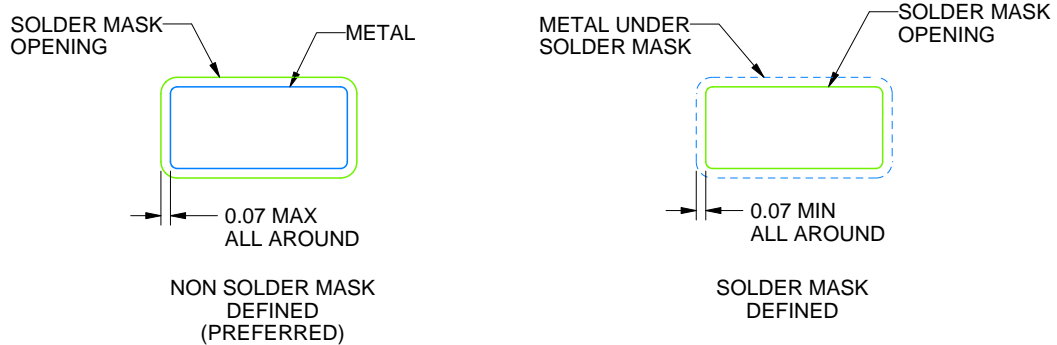

SOLDER MASK DETAILS

4214838/F 08/2024

NOTES: (continued)

- 5. Publication IPC-7351 may have alternate designs.
- 6. Solder mask tolerances between and around signal pads can vary based on board fabrication site.

# EXAMPLE STENCIL DESIGN

DBZ0003A

SOT-23 - 1.12 mm max height

SMALL OUTLINE TRANSISTOR

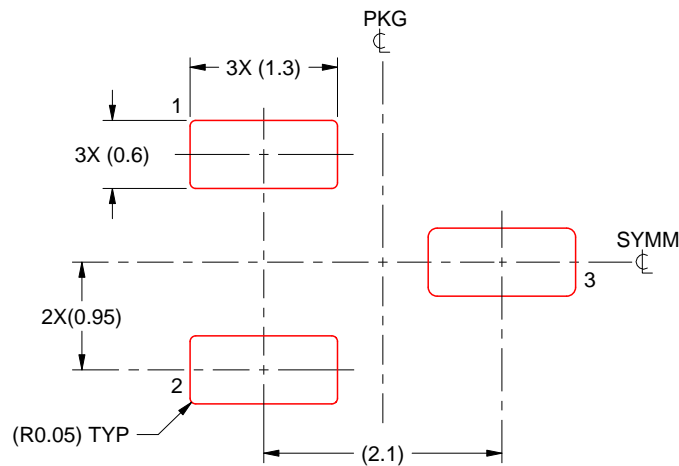

SOLDER PASTE EXAMPLE  
BASED ON 0.125 THICK STENCIL  
SCALE:15X

4214838/F 08/2024

NOTES: (continued)

7. Laser cutting apertures with trapezoidal walls and rounded corners may offer better paste release. IPC-7525 may have alternate design recommendations.
8. Board assembly site may have different recommendations for stencil design.

# DCK0005A



## PACKAGE OUTLINE

SOT - 1.1 max height

SMALL OUTLINE TRANSISTOR

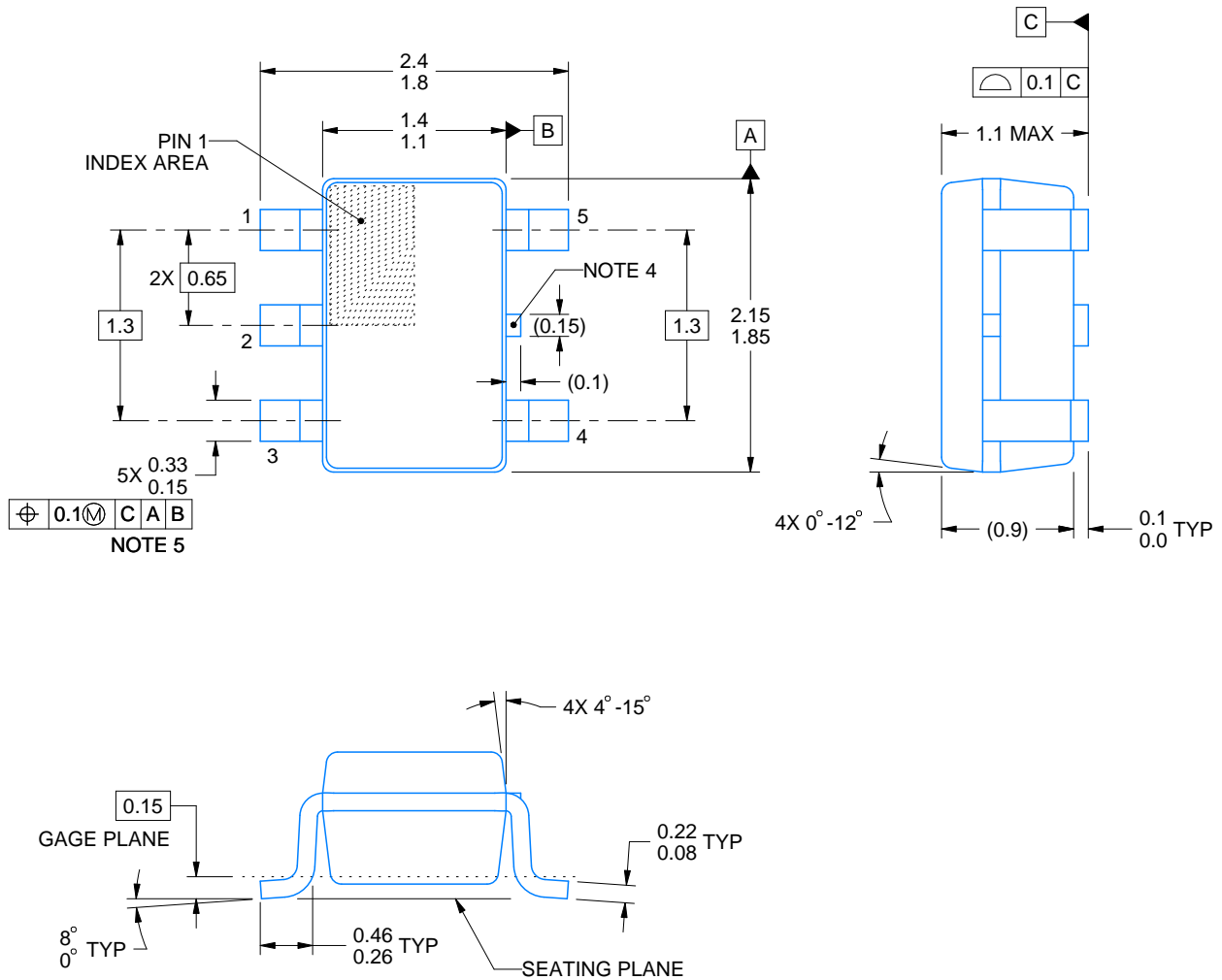

4214834/G 11/2024

### NOTES:

1. All linear dimensions are in millimeters. Any dimensions in parenthesis are for reference only. Dimensioning and tolerancing per ASME Y14.5M.
2. This drawing is subject to change without notice.
3. Reference JEDEC MO-203.
4. Support pin may differ or may not be present.
5. Lead width does not comply with JEDEC.
6. Body dimensions do not include mold flash, protrusions, or gate burrs. Mold flash, protrusions, or gate burrs shall not exceed 0.25mm per side

# EXAMPLE BOARD LAYOUT

DCK0005A

SOT - 1.1 max height

SMALL OUTLINE TRANSISTOR



LAND PATTERN EXAMPLE  
EXPOSED METAL SHOWN  
SCALE:18X

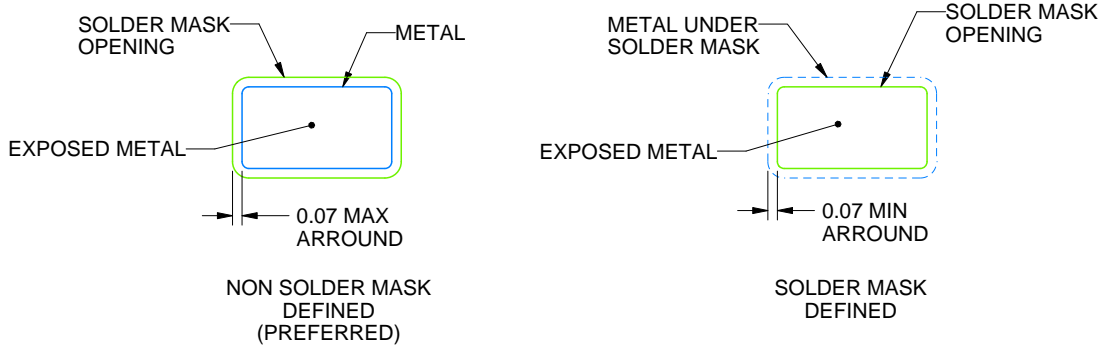

SOLDER MASK DETAILS

4214834/G 11/2024

NOTES: (continued)

- 7. Publication IPC-7351 may have alternate designs.
- 8. Solder mask tolerances between and around signal pads can vary based on board fabrication site.

# EXAMPLE STENCIL DESIGN

DCK0005A

SOT - 1.1 max height

SMALL OUTLINE TRANSISTOR



SOLDER PASTE EXAMPLE  
BASED ON 0.125 THICK STENCIL  
SCALE: 18X

4214834/G 11/2024

NOTES: (continued)

9. Laser cutting apertures with trapezoidal walls and rounded corners may offer better paste release. IPC-7525 may have alternate design recommendations.
10. Board assembly site may have different recommendations for stencil design.

LP0003A



# PACKAGE OUTLINE

TO-92 - 5.34 mm max height

TO-92

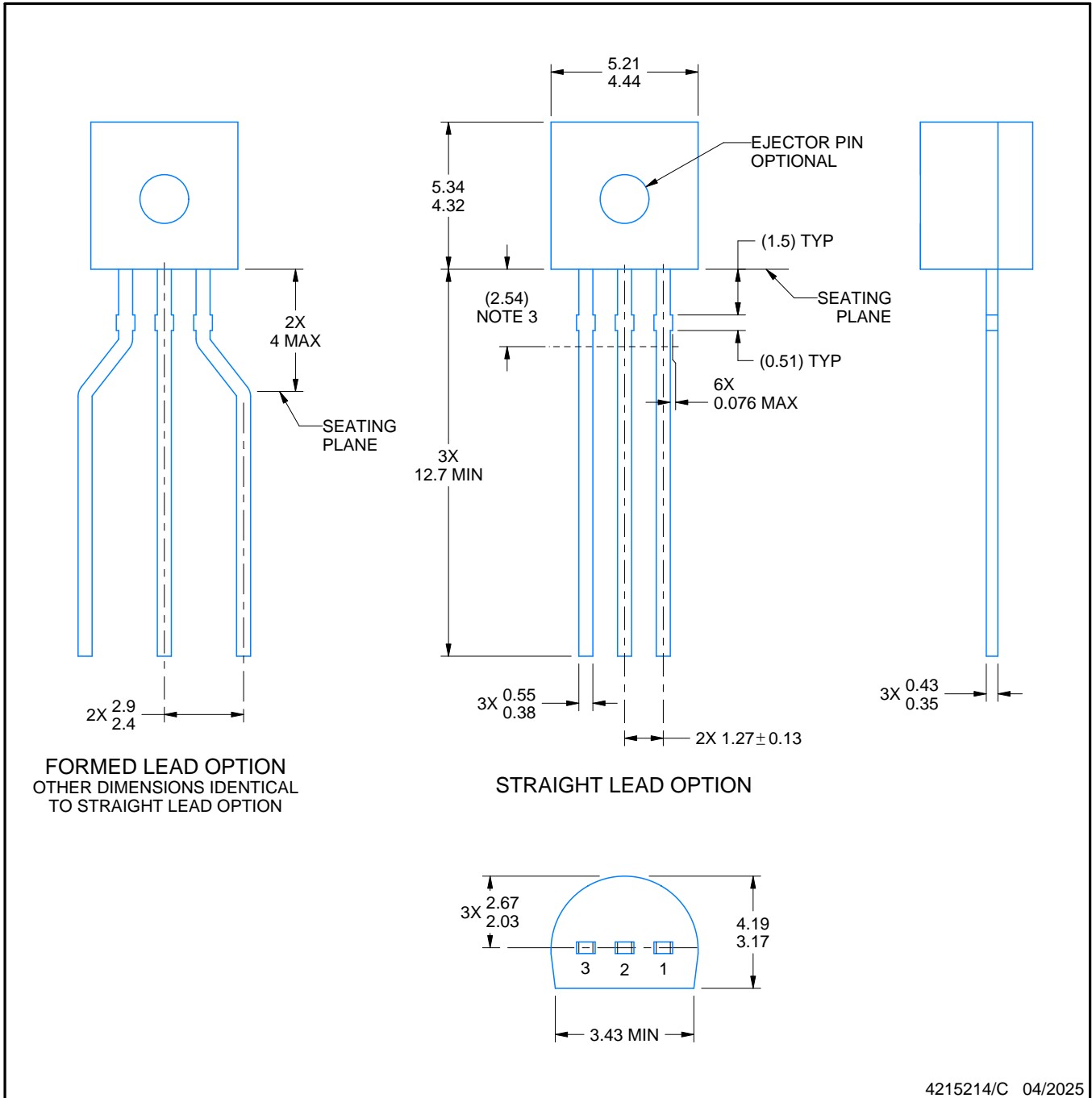

4215214/C 04/2025

NOTES:

1. All linear dimensions are in millimeters. Any dimensions in parenthesis are for reference only. Dimensioning and tolerancing per ASME Y14.5M.
2. This drawing is subject to change without notice.
3. Lead dimensions are not controlled within this area.
4. Reference JEDEC TO-226, variation AA.
5. Shipping method:
  - a. Straight lead option available in bulk pack only.
  - b. Formed lead option available in tape and reel or ammo pack.
  - c. Specific products can be offered in limited combinations of shipping medium and lead options.
  - d. Consult product folder for more information on available options.



# TAPE SPECIFICATIONS

LP0003A

TO-92 - 5.34 mm max height

TO-92

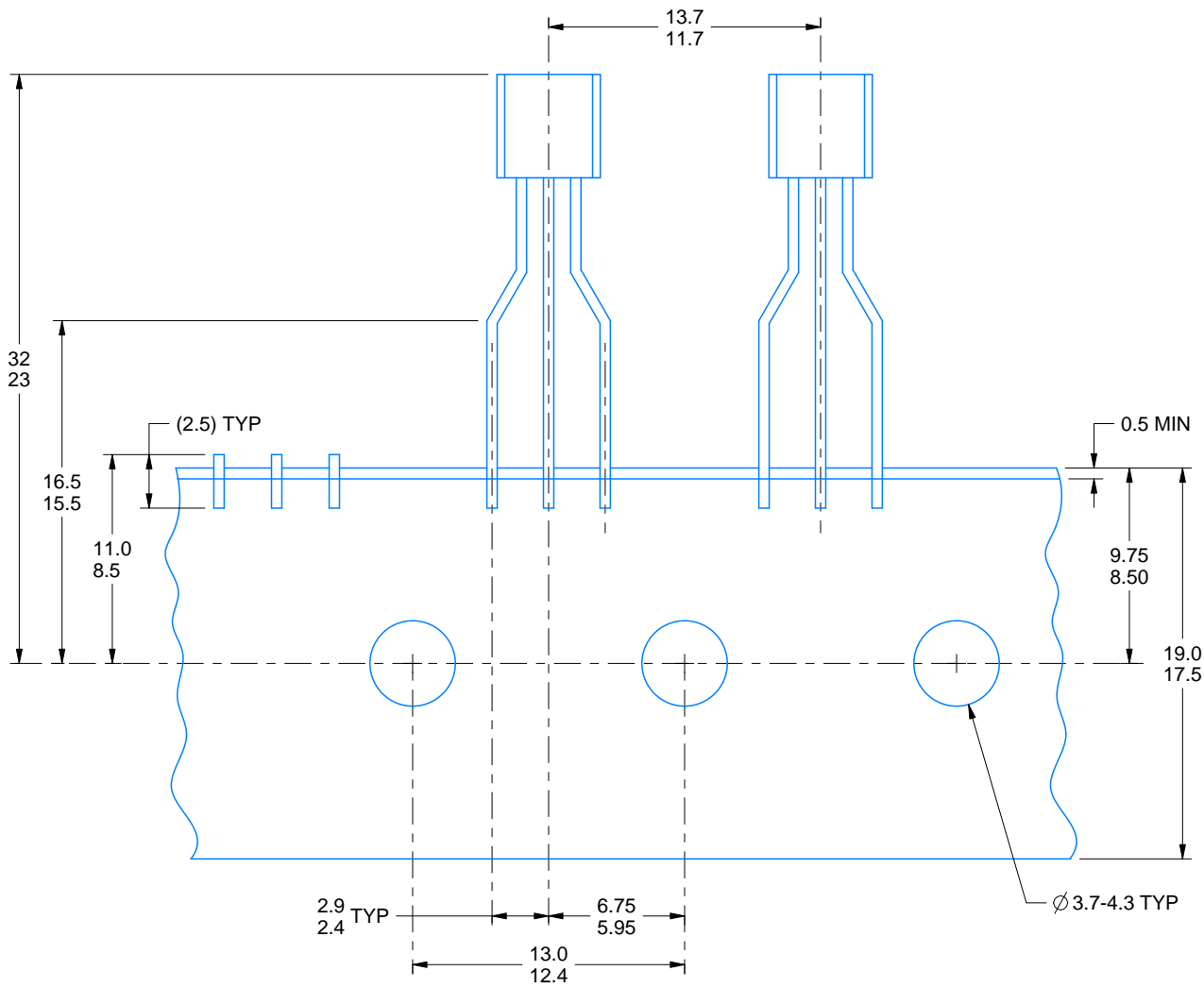

FOR FORMED LEAD OPTION PACKAGE

4215214/C 04/2025

## IMPORTANT NOTICE AND DISCLAIMER

TI PROVIDES TECHNICAL AND RELIABILITY DATA (INCLUDING DATASHEETS), DESIGN RESOURCES (INCLUDING REFERENCE DESIGNS), APPLICATION OR OTHER DESIGN ADVICE, WEB TOOLS, SAFETY INFORMATION, AND OTHER RESOURCES "AS IS" AND WITH ALL FAULTS, AND DISCLAIMS ALL WARRANTIES, EXPRESS AND IMPLIED, INCLUDING WITHOUT LIMITATION ANY IMPLIED WARRANTIES OF MERCHANTABILITY, FITNESS FOR A PARTICULAR PURPOSE OR NON-INFRINGEMENT OF THIRD PARTY INTELLECTUAL PROPERTY RIGHTS.

These resources are intended for skilled developers designing with TI products. You are solely responsible for (1) selecting the appropriate TI products for your application, (2) designing, validating and testing your application, and (3) ensuring your application meets applicable standards, and any other safety, security, regulatory or other requirements.

These resources are subject to change without notice. TI grants you permission to use these resources only for development of an application that uses the TI products described in the resource. Other reproduction and display of these resources is prohibited. No license is granted to any other TI intellectual property right or to any third party intellectual property right. TI disclaims responsibility for, and you fully indemnify TI and its representatives against any claims, damages, costs, losses, and liabilities arising out of your use of these resources.

TI's products are provided subject to [TI's Terms of Sale](#), [TI's General Quality Guidelines](#), or other applicable terms available either on [ti.com](http://ti.com) or provided in conjunction with such TI products. TI's provision of these resources does not expand or otherwise alter TI's applicable warranties or warranty disclaimers for TI products. Unless TI explicitly designates a product as custom or customer-specified, TI products are standard, catalog, general purpose devices.

TI objects to and rejects any additional or different terms you may propose.

Copyright © 2026, Texas Instruments Incorporated

Last updated 10/2025