

# DRV8889-Q1, DRV8889A-Q1 Automotive Stepper Driver with Integrated Current Sense, 1/256 Micro-Stepping, and Stall Detection

## 1 Features

- AEC-Q100 Qualified for Automotive
- Up to 1/256 microstepping
- Integrated current sense functionality
  - No sense resistors required
- Smart tune decay technology, Fixed slow, and mixed decay options
- 4.5 to 45-V Operating supply voltage range
- Pin to pin  $R_{DS(ON)}$  variants:
  - DRV8889/A-Q1: 900 m $\Omega$  HS + LS at 25°C
  - **DRV8889-Q1**: 1200 m $\Omega$  HS + LS at 25°C
- High current capacity per bridge
  - DRV8889/A-Q1: 2.4-A peak, 1.5-A full-scale
  - **DRV8889-Q1**: 1.7-A peak, 1-A full-scale
- TRQ\_DAC bits to scale full-scale current
- Configurable off-time PWM chopping
- Simple STEP/DIR interface
- SPI with daisy chain support
- Low-current sleep mode (2  $\mu$ A)
- Programmable output slew rate
- Programmable open load detection time with DRV8889A-Q1
- Spread spectrum clocking to minimize EMI
- Protection features
  - VM undervoltage lockout
  - Overcurrent protection
  - Stall detection
  - Open load detection
  - Overtemperature warning and shutdown
  - Undertemperature warning
  - Fault condition indication pin (nFAULT)
- **Functional Safety-Capable**
  - [Documentation available to aid functional safety system design](#)

## 2 Applications

- [Automotive bipolar stepper motors](#)
- [Headlight position adjustment](#)
- [Head-up display \(HUD\)](#)
- [HVAC stepper motors](#)
- [Electronic fuel injection \(EFI\)](#)

## 3 Description

The DRV8889-Q1 and DRV8889A-Q1 are fully integrated stepper motor drivers, supporting up to 1.5 A full scale current with an internal microstepping indexer, smart tune decay technology, advanced stall detection algorithm, and integrated current sensing.

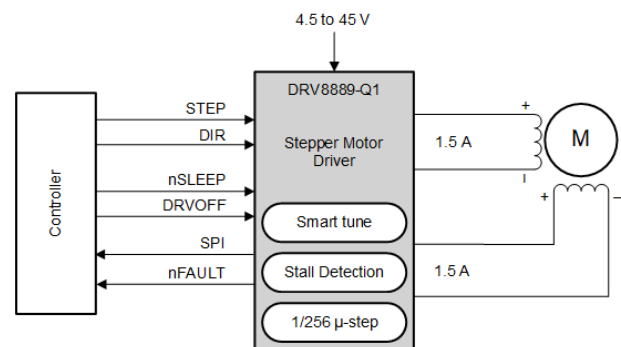
The device supports up to 1/256 levels of microstepping to enable a smooth motion profile. Integrated current sensing eliminates the need for two external resistors, saving board space and cost. With advanced stall detection algorithm, designers can detect if the motor stopped and take action as needed which can improve efficiency and reduce noise. The device provides 8 decay mode options including: smart tune, slow, and mixed decay options. Smart tune automatically adjusts for optimal current regulation performance. The device also includes an integrated torque DAC which allows for the controller to scale the output current through SPI without needing to scale the VREF voltage reference. A low-power sleep mode is provided using an nSLEEP pin. The device features full duplex, 4-wire synchronous SPI communication, with daisy chain support for up to 63 devices connected in series, for configurability and detailed fault reporting. View our full portfolio of [stepper motor drivers](#) on ti.com.

### Device Information

PART NUMBER <sup>(1)</sup>	PACKAGE	PACKAGE SIZE (NOM) <sup>(2)</sup>
DRV8889QPWPRQ1	HTSSOP (24)	7.80mm × 6.40mm
DRV8889QWRGERQ1	VQFN (24) (Wettable Flank)	4.00mm × 4.00mm
DRV8889AQPWPRQ1	HTSSOP (24)	7.80mm × 6.40mm
DRV8889AQWRGERQ1	VQFN (24) (Wettable Flank)	4.00mm × 4.00mm

(1) For all available packages, see the orderable addendum at the end of the data sheet.

(2) The package size (length x width) is a nominal value and includes pins, where applicable.



**Simplified Schematic**



## Table of Contents

<b>1 Features</b> .....	1	6.4 Device Functional Modes.....	38
<b>2 Applications</b> .....	1	6.5 Programming.....	39
<b>3 Description</b> .....	1	<b>7 Register Maps</b> .....	45
<b>4 Pin Configuration and Functions</b> .....	3	<b>8 Application and Implementation</b> .....	53
Pin Functions.....	4	8.1 Application Information.....	53
<b>5 Specifications</b> .....	5	8.2 Typical Application.....	53
5.1 Absolute Maximum Ratings.....	5	8.3 Power Supply Recommendations.....	66
5.2 ESD Ratings.....	5	8.4 Layout.....	67
5.3 Recommended Operating Conditions.....	6	<b>9 Device and Documentation Support</b> .....	70
5.4 Thermal Information.....	6	9.1 Documentation Support.....	70
5.5 Electrical Characteristics.....	7	9.2 Receiving Notification of Documentation Updates....	70
5.6 SPI Timing Requirements.....	9	9.3 Support Resources.....	70
5.7 Indexer Timing Requirements.....	10	9.4 Trademarks.....	70
5.8 Typical Characteristics.....	11	9.5 Electrostatic Discharge Caution.....	70
<b>6 Detailed Description</b> .....	13	9.6 Glossary.....	70
6.1 Overview.....	13	<b>10 Revision History</b> .....	70
6.2 Functional Block Diagram.....	14	<b>11 Mechanical, Packaging, and Orderable</b>	
6.3 Feature Description.....	15	<b>Information</b> .....	71

### 4 Pin Configuration and Functions

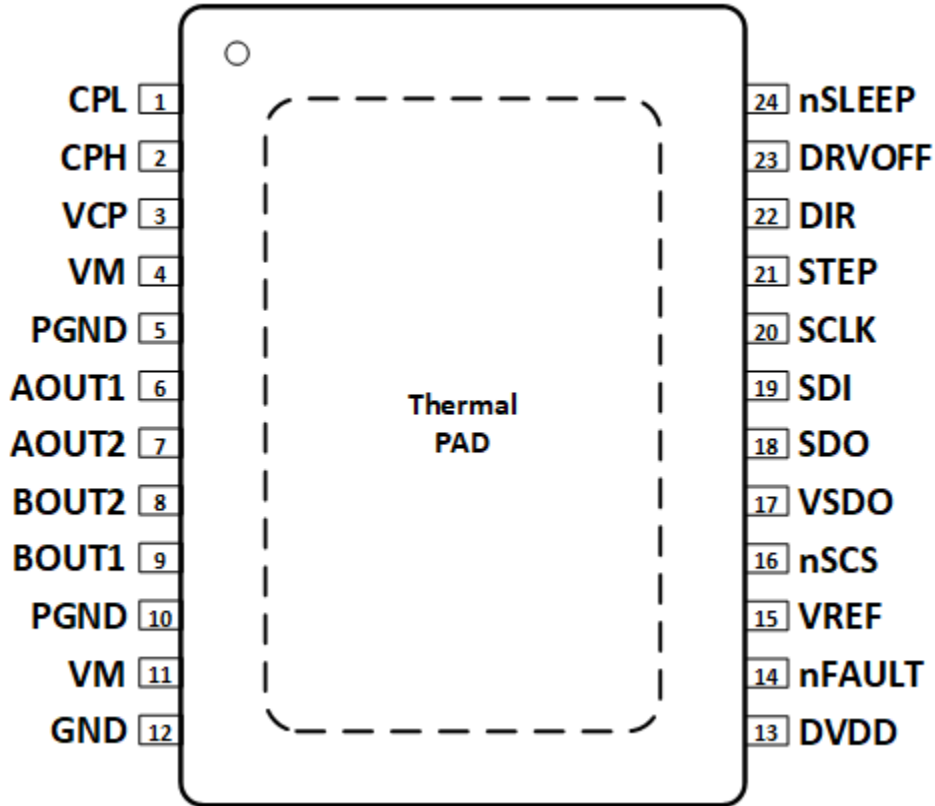


Figure 4-1. PWP PowerPAD™ Package 24-Pin HTSSOP Top View

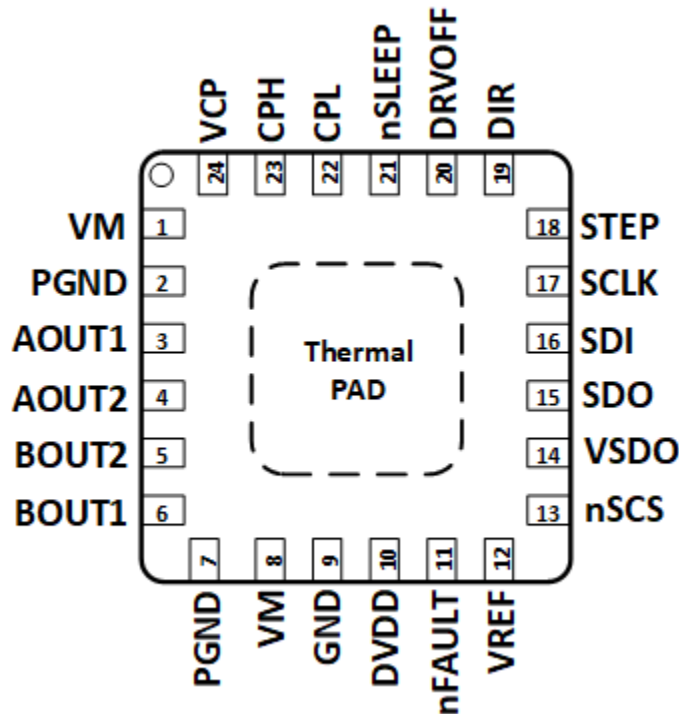


Figure 4-2. WRGE Package 24-Pin VQFN With Exposed Thermal Pad Top View

## Pin Functions

NAME	PIN NO.		I/O	TYPE	DESCRIPTION
	HTSSOP	VQFN			
	AOUT1	6			
AOUT2	7	4	O	Output	Winding A output. Connect to stepper motor winding.
PGND	5, 10	2, 7	—	Power	Power ground. Both PGND pins are shorted internally. Connect to system ground on PCB.
BOUT1	9	6	O	Output	Winding B output. Connect to stepper motor winding
BOUT2	8	5	O	Output	Winding B output. Connect to stepper motor winding
CPH	2	23	—	Power	Charge pump switching node. Connect a X7R, 0.022- $\mu$ F, VM-rated ceramic capacitor from CPH to CPL.
CPL	1	22			
DIR	22	19	I	Input	Direction input. Logic level sets the direction of stepping; internal pull-down resistor.
DRVOFF	23	20	I	Input	Logic high to disable device outputs; logic low to enable; internal pullup to DVDD.
DVDD	13	10		Power	Logic supply voltage. Connect a X7R, 0.47- $\mu$ F, 6.3-V or 10-V rated ceramic capacitor to GND.
GND	12	9	—	Power	Device ground. Connect to system ground.
VREF	15	12	I	Input	Current set reference input. Maximum value 3.3 V. DVDD can be used to provide VREF through a resistor divider.
SCLK	20	17	I	Input	Serial clock input. Serial data is shifted out and captured on the corresponding rising and falling edge on this pin.
SDI	19	16	I	Input	Serial data input. Data is captured on the falling edge of the SCLK pin
SDO	18	15	O	Push Pull	Serial data output. Data is shifted out on the rising edge of the SCLK pin.
STEP	21	18	I	Input	Step input. A rising edge causes the indexer to advance one step; internal pull-down resistor.
VCP	3	24	—	Power	Charge pump output. Connect a X7R, 0.22- $\mu$ F, 16-V ceramic capacitor to VM.
VM	4, 11	1, 8	—	Power	Power supply. Connect to motor supply voltage and bypass to GND with two 0.01- $\mu$ F ceramic capacitors (one for each pin) plus a bulk capacitor rated for VM.
VSDO	17	14		Power	Supply pin for SDO output. Connect to 5-V or 3.3-V depending on the desired logic level.
nFAULT	14	11	O	Open Drain	Fault indication. Pulled logic low with fault condition; open-drain output requires an external pullup resistor.
nSCS	16	13	I	Input	Serial chip select. An active low on this pin enables the serial interface communications. Internal pullup to DVDD.
nSLEEP	24	21	I	Input	Sleep mode input. Logic high to enable device; logic low to enter low-power sleep mode; internal pull-down resistor.
PAD	-	-	-	-	Thermal pad. Connect to system ground.

## 5 Specifications

### 5.1 Absolute Maximum Ratings

over operating free-air temperature range (unless otherwise noted) <sup>1</sup>

	MIN	MAX	UNIT
Power supply voltage (VM)	-0.3	50	V
Charge pump voltage (VCP, CPH)	-0.3	VM + 7	V
Charge pump negative switching pin (CPL)	-0.3	VM	V
nSLEEP pin (nSLEEP)	-0.3	VM	V
Internal regulator voltage (DVDD)	-0.3	5.75	V
SDO output reference voltage (VSDO)	-0.3	5.75	V
Control pin voltage (STEP, DIR, DRVOFF, nFAULT, SDI, SDO, SCLK, nSCS)	-0.3	5.75	V
Open drain output current (nFAULT)	0	10	mA
Reference input pin voltage (VREF)	-0.3	5.75	V
Continuous phase node pin voltage (AOUT1, AOUT2, BOUT1, BOUT2)	-1.0	VM + 1.0	V
Transient 100 ns phase node pin voltage (AOUT1, AOUT2, BOUT1, BOUT2)	-3.0	VM + 3.0	V
Peak drive current (AOUT1, AOUT2, BOUT1, BOUT2)	Internally Limited		A
Operating ambient temperature, T <sub>A</sub>	-40	125	°C
Operating junction temperature, T <sub>J</sub>	-40	150	°C
Storage temperature, T <sub>stg</sub>	-65	150	°C

1. Stresses beyond those listed under *Absolute Maximum Ratings* may cause permanent damage to the device. These are stress ratings only, which do not imply functional operation of the device at these or any other conditions beyond those indicated under *Recommended Operating Conditions*. Exposure to absolute-maximum-rated conditions for extended periods may affect device reliability.

### 5.2 ESD Ratings

		VALUE	UNIT	
V <sub>(ESD)</sub>	Electrostatic discharge	Human body model (HBM), per AEC Q100-0021	±2000	
		Charged device model (CDM), per AEC Q100-011	Corner pins for PWP (1, 12, 13, and 24)	±750
			Other pins	±500

1. AECQ100-002 indicates that HBM stressing shall be in accordance with the ANSI/ESDA/JEDEC JS-001 specification.

### 5.3 Recommended Operating Conditions

over operating free-air temperature range (unless otherwise noted)<sup>1</sup>

		MIN	MAX	UNIT
$V_{VM}$	Supply voltage range for normal (DC) operation	4.5	45	V
$V_I$	Logic level input voltage	0	5.5	V
$V_{SDO}$	SDO buffer supply voltage	2.9	5.5	V
$V_{VREF}$	VREF voltage	0.05	3.3	V
$f_{STEP}$	Applied STEP signal (STEP)	0	100 (2)	kHz
$I_{FS}$	Motor full-scale current (xOUTx)	0	1.5 (3)	A
$I_{rms}$	Motor RMS current (xOUTx)	0	1.1 (3)	A
$T_A$	Operating ambient temperature	-40	125	°C
$T_J$	Operating junction temperature	-40	150	°C

1. Device is functional, however, deviations of the specified electrical characteristics are possible
2. STEP input can operate up to 500 kHz, but system bandwidth is limited by the motor load
3. Power dissipation and thermal limits must be observed

### 5.4 Thermal Information

THERMAL METRIC 1		PWP (HTSSOP)	RGE (VQFN)	UNIT
		24 PINS	24 PINS	
$R_{\theta JA}$	Junction-to-ambient thermal resistance	30.9	40.7	°C/W
$R_{\theta JC(top)}$	Junction-to-case (top) thermal resistance	25.2	31.1	°C/W
$R_{\theta JB}$	Junction-to-board thermal resistance	11.3	17.9	°C/W
$\psi_{JT}$	Junction-to-top characterization parameter	0.4	0.6	°C/W
$\psi_{JB}$	Junction-to-board characterization parameter	11.3	17.8	°C/W
$R_{\theta JC(bot)}$	Junction-to-case (bottom) thermal resistance	3.1	4.3	°C/W

1. For more information about traditional and new thermalmetrics, see the [Semiconductor and IC Package Thermal Metrics application report](#).

## 5.5 Electrical Characteristics

Over recommended operating conditions unless otherwise noted. Typical limits apply for  $T_J = 25^\circ\text{C}$  and  $V_{VM} = 13.5\text{ V}$

PARAMETER		TEST CONDITIONS	MIN	TYP	MAX	UNIT
<b>POWER SUPPLIES (VM, DVDD, VSDO)</b>						
$I_{VM}$	VM operating supply current	DRVOFF = 0, nSLEEP = 1, No output		5	7	mA
$I_{VMQ}$	VM sleep mode supply current	nSLEEP = 0		2	4	$\mu\text{A}$
$t_{SLEEP}$	Sleep time	nSLEEP = 0 to sleep-mode	75			$\mu\text{s}$
$t_{RESET}$	nSLEEP reset pulse	nSLEEP low to only clear fault registers	18		35	$\mu\text{s}$
$t_{WAKE}$	Wake-up time	DRV8889-Q1, nSLEEP = 1 to output transition		0.6	0.9	ms
		DRV8889A-Q1, nSLEEP = 1 to SPI ready		100	200	$\mu\text{s}$
$t_{ON}$	Turn-on time	DRV8889-Q1, VM > UVLO to output transition		0.6	0.9	ms
		DRV8889A-Q1, SPI ready, VM > UVLO to output transition		0.4	0.9	ms
$V_{DVDD}$	Internal regulator voltage	No external load, $6\text{ V} < V_{VM} < 45\text{ V}$	4.5	5	5.5	V
<b>CHARGE PUMP (VCP, CPH, CPL)</b>						
$V_{VCP}$	VCP operating voltage			VM + 5		V
$f_{(VCP)}$	Charge pump switching frequency	$V_{VM} > UVLO$ ; nSLEEP = 1		400		kHz
<b>LOGIC-LEVEL INPUTS (STEP, DIR, nSLEEP, nSCS, SCLK, SDI, DRVOFF)</b>						
$V_{IL}$	Input logic-low voltage		0		0.6	V
$V_{IH}$	Input logic-high voltage		1.5		5.5	V
$V_{HYS}$	Input logic hysteresis			150		mV
$I_{IL1}$	Input logic-low current	VIN = 0 V (nSCS, DRVOFF)	8		12	$\mu\text{A}$
$I_{IL2}$	Input logic-low current	VIN = 0 V	-1		1	$\mu\text{A}$
$I_{IH1}$	Input logic-high current	VIN = DVDD (nSCS, DRVOFF)			500	nA
$I_{IH2}$	Input logic-high current	VIN = 5 V			50	$\mu\text{A}$
<b>PUSH-PULL OUTPUT (SDO)</b>						
$R_{PD,SDO}$	Internal pull-down resistance	5mA load, with respect to GND		40	75	$\Omega$
$R_{PU,SDO}$	Internal pull-up resistance	5mA load, with respect to VSDO		30	60	$\Omega$
$I_{SDO}$	SDO Leakage Current	SDO = VSDO and 0V	-1		1	$\mu\text{A}$
<b>CONTROL OUTPUTS (nFAULT)</b>						
$V_{OL}$	Output logic-low voltage	$I_O = 5\text{ mA}$			0.4	V
$I_{OH}$	Output logic-high leakage	$V_{VM} = 13.5\text{ V}$	-1		1	$\mu\text{A}$

Over recommended operating conditions unless otherwise noted. Typical limits apply for  $T_J = 25^\circ\text{C}$  and  $V_{VM} = 13.5\text{ V}$ 

PARAMETER		TEST CONDITIONS	MIN	TYP	MAX	UNIT
<b>MOTOR DRIVER OUTPUTS (AOUT1, AOUT2, BOUT1, BOUT2)</b>						
$R_{DS(OH)}$	High-side FET on resistance	$T_J = 25^\circ\text{C}, I_O = -1\text{ A}$		450	550	m $\Omega$
		$T_J = 125^\circ\text{C}, I_O = -1\text{ A}$		700	850	m $\Omega$
		$T_J = 150^\circ\text{C}, I_O = -1\text{ A}$		780	950	m $\Omega$
$R_{DS(ONL)}$	Low-side FET on resistance	$T_J = 25^\circ\text{C}, I_O = 1\text{ A}$		450	550	m $\Omega$
		$T_J = 125^\circ\text{C}, I_O = 1\text{ A}$		700	850	m $\Omega$
		$T_J = 150^\circ\text{C}, I_O = 1\text{ A}$		780	950	m $\Omega$
$t_{SR}$	Output slew rate	SR = 00b, VM = 13.5 V, $I_O = 0.5\text{ A}$		10		V/ $\mu\text{s}$
		SR = 01b, VM = 13.5 V, $I_O = 0.5\text{ A}$		35		
		SR = 10b, VM = 13.5 V, $I_O = 0.5\text{ A}$		50		
		SR = 11b, VM = 13.5 V, $I_O = 0.5\text{ A}$		105		
<b>PWM CURRENT CONTROL (VREF)</b>						
$K_V$	Transimpedance gain			2.2		V/A
$t_{OFF}$	PWM off-time	TOFF = 00b		7		$\mu\text{s}$
		TOFF = 01b		16		
		TOFF = 10b		24		
		TOFF = 11b		32		
$\Delta I_{TRIP}$	Current trip accuracy	$I_O = 1.5\text{ A}, 10\%$ to 20% current setting	-13		10	%
		$I_O = 1.5\text{ A}, 20\%$ to 67% current setting	-8		8	
		$I_O = 1.5\text{ A}, 67\%$ to 100% current setting	-7.5		7.5	
$I_{O,CH}$	AOUT and BOUT current matching	$I_O = 1.5\text{ A}$	-2.5		2.5	%
<b>PROTECTION CIRCUITS</b>						
$V_{UVLO}$	VM UVLO lockout	VM falling, UVLO falling	4.15	4.25	4.35	V
		VM rising, UVLO rising	4.25	4.35	4.45	
$V_{UVLO,HYS}$	Undervoltage hysteresis	Rising to falling threshold		100		mV
$V_{RST}$	VM UVLO reset	VM falling, device reset, no SPI communications			3.9	V
$V_{CPUV}$	Charge pump undervoltage	VCP falling; CPUV report		VM + 2		V
$I_{OCP}$	Overcurrent protection	Current through any FET	2.4			A
$t_{OCP}$	Overcurrent deglitch time	$V_{VM} < 37\text{ V}$		3		$\mu\text{s}$
		$V_{VM} \geq 37\text{ V}$		0.5		
$t_{RETRY}$	Overcurrent retry time	OCP_MODE = 1b		4		ms
$t_{OL}$	Open load detection time	DRV8889-Q1, EN_OL = 1b			200	ms
		DRV8889A-Q1, EN_OL = 1b, OL_TIME = 00b			200	
		DRV8889A-Q1, EN_OL = 1b, OL_TIME = 01b			125	
		DRV8889A-Q1, EN_OL = 1b, OL_TIME = 10b			75	
		DRV8889A-Q1, EN_OL = 1b, OL_TIME = 11b			3	
$I_{OL}$	Open load current threshold			30		mA
$T_{OTW}$	Overtemperature warning	Die temperature $T_J$	135	150	165	$^\circ\text{C}$
$T_{UTW}$	Undertemperature warning	Die temperature $T_J$	-25	-10	5	$^\circ\text{C}$
$T_{OTSD}$	Thermal shutdown	Die temperature $T_J$	150	165	180	$^\circ\text{C}$

Over recommended operating conditions unless otherwise noted. Typical limits apply for  $T_J = 25^\circ\text{C}$  and  $V_{VM} = 13.5\text{ V}$

PARAMETER		TEST CONDITIONS	MIN	TYP	MAX	UNIT
$T_{\text{HYS\_OTSD}}$	Thermal shutdown hysteresis	Die temperature $T_J$		20		$^\circ\text{C}$
$T_{\text{HYS\_OTW}}$	Overtemperature warning hysteresis	Die temperature $T_J$		20		$^\circ\text{C}$
$T_{\text{HYS\_UTW}}$	Undertemperature warning hysteresis	Die temperature $T_J$		10		$^\circ\text{C}$

## 5.6 SPI Timing Requirements

		MIN	NOM	MAX	UNIT
$t_{\text{(READY)}}$	SPI ready, $V_M > V_{\text{RST}}$		1		ms
$t_{\text{(CLK)}}$	SCLK minimum period	100			ns
$t_{\text{(CLKH)}}$	SCLK minimum high time	50			ns
$t_{\text{(CLKL)}}$	SCLK minimum low time	50			ns
$t_{\text{su(SDI)}}$	SDI input setup time	20			ns
$t_{\text{h(SDI)}}$	SDI input hold time	30			ns
$t_{\text{d(SDO)}}$	SDO output delay time, SCLK high to SDO valid, $C_L = 20\text{ pF}$			30	ns
$t_{\text{su(nSCS)}}$	nSCS input setup time	50			ns
$t_{\text{h(nSCS)}}$	nSCS input hold time	50			ns
$t_{\text{(HI_nSCS)}}$	nSCS minimum high time before active low	1			$\mu\text{s}$
$t_{\text{dis(nSCS)}}$	nSCS disable time, nSCS high to SDO high impedance		10		ns

## 5.7 Indexer Timing Requirements

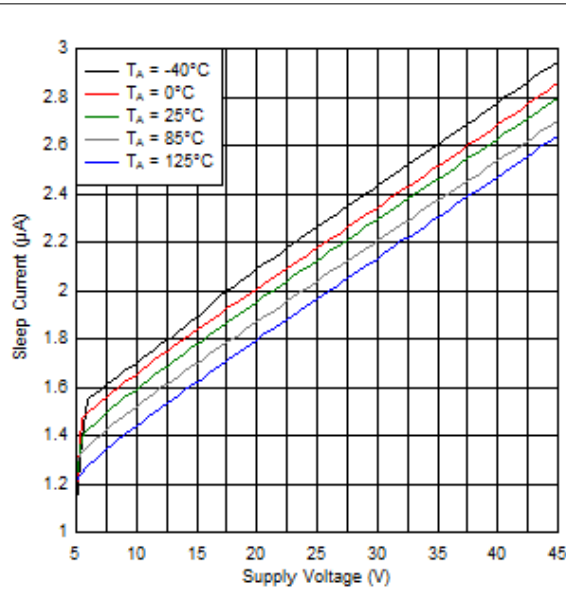
Over recommended operating conditions unless otherwise noted. Typical limits apply for  $T_J = 25^\circ\text{C}$  and  $V_{VM} = 13.5\text{ V}$

NO.			MIN	MAX	UNIT
1	$f_{\text{STEP}}$	Step frequency		500 <sup>(1)</sup>	kHz
2	$t_{\text{WH(STEP)}}$	Pulse duration, STEP high	970		ns
3	$t_{\text{WL(STEP)}}$	Pulse duration, STEP low	970		ns
4	$t_{\text{SU(DIR, Mx)}}$	Setup time, DIR to STEP rising	200		ns
5	$t_{\text{H(DIR, Mx)}}$	Hold time, DIR to STEP rising	200		ns

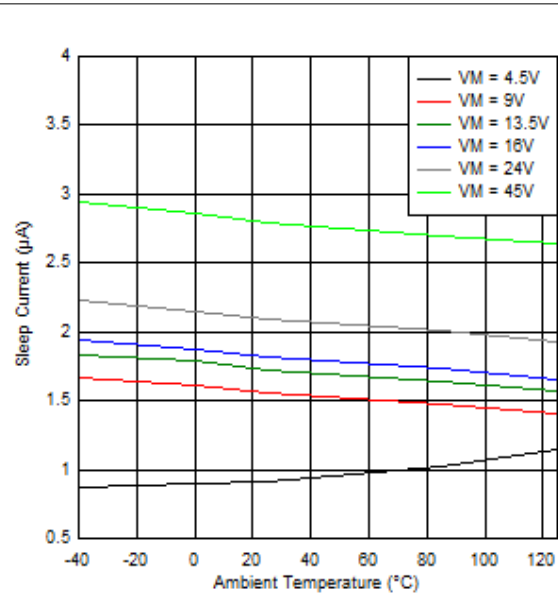
(1) STEP input can operate up to 500 kHz, but system bandwidth is limited by the motor load.

## 5.8 Typical Characteristics

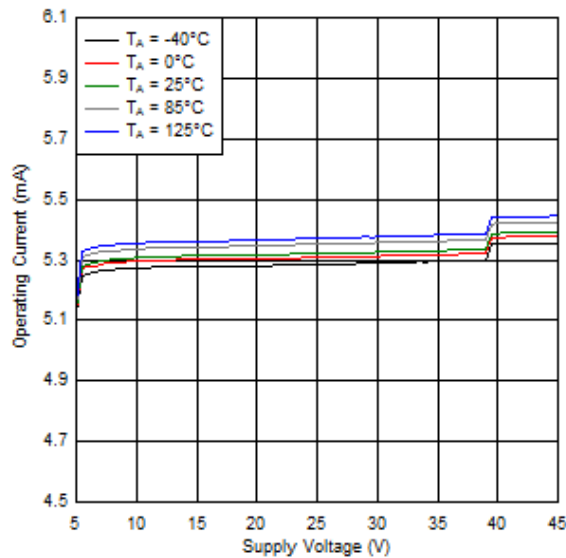
Over recommended operating conditions (unless otherwise noted)



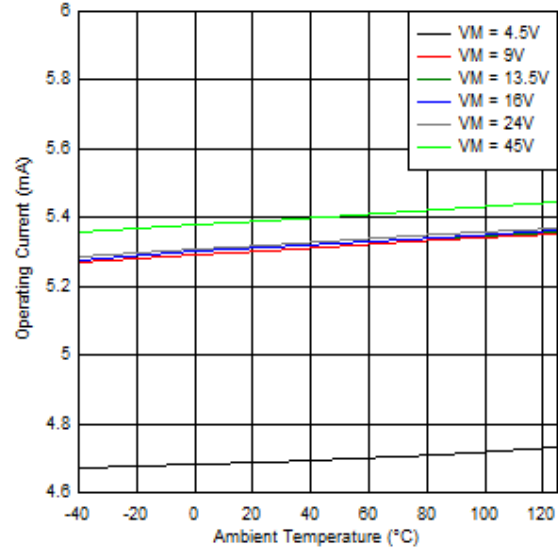
**Figure 5-1. Sleep Current over VM**



**Figure 5-2. Sleep Current over Temperature**



**Figure 5-3. Operating Current over VM**



**Figure 5-4. Operating Current over Temperature**

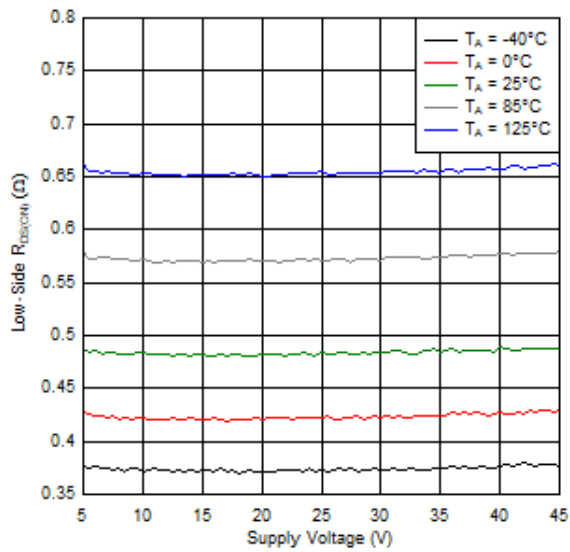


Figure 5-5. Low-Side  $R_{DS(ON)}$  over VM

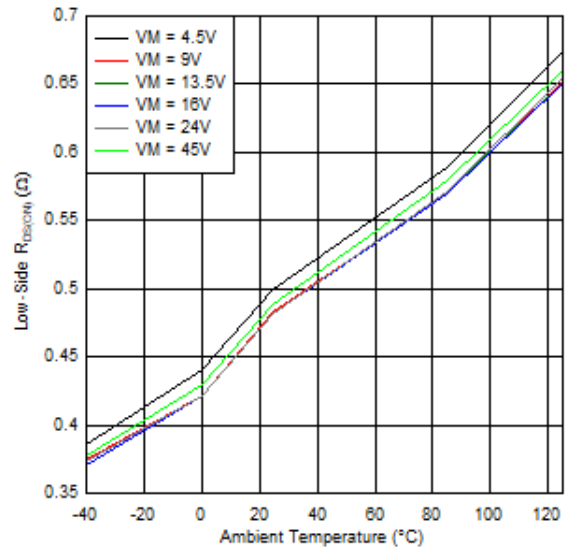


Figure 5-6. Low-Side  $R_{DS(ON)}$  over Temperature

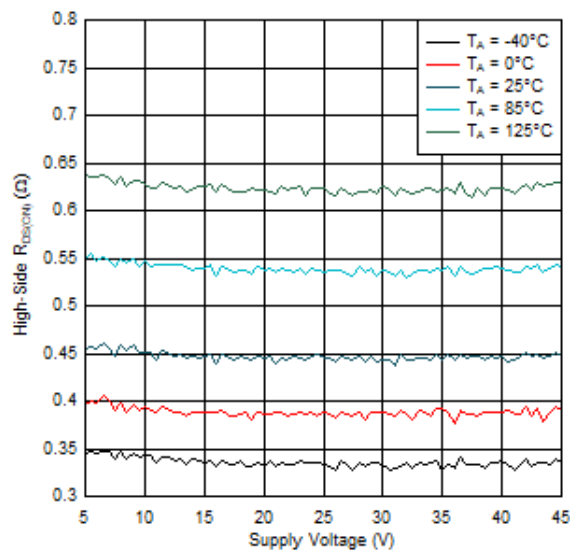


Figure 5-7. High-Side  $R_{DS(ON)}$  over VM

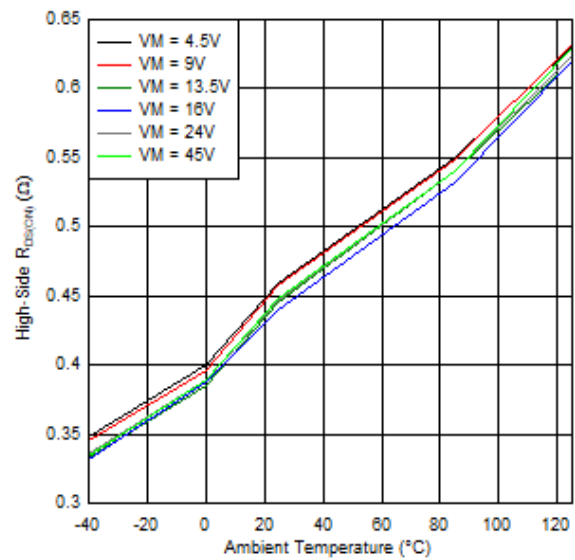


Figure 5-8. High-Side  $R_{DS(ON)}$  over Temperature

## 6 Detailed Description

### 6.1 Overview

The DRV8889-Q1 and DRV8889A-Q1 devices are integrated motor-driver solutions for bipolar stepper motors. The device integrates two N-channel power MOSFET H-bridges, integrated current sense and regulation circuitry, and a microstepping indexer. The device can be powered with a supply voltage from 4.5 to 45 V and is capable of providing an output current up to 2.4-A peak, 1.5-A full-scale, or 1.1-A root mean square (rms). The actual full-scale and rms current depends on the ambient temperature, supply voltage, and PCB thermal capability. Compared to the DRV8889-Q1, the DRV8889A-Q1 features additional settings for the open-load detection time and slow-decay to drive blanking time. Additionally, the H-bridges are by default enabled after power-up for the DRV8889-Q1 and disabled for the DRV8889A-Q1.

The device uses an integrated current-sense architecture which eliminates the need for two external power sense resistors. This architecture removes the power dissipated in the sense resistors by using a current mirror approach and using the internal power MOSFETs for current sensing. The current regulation set point is adjusted by the voltage at the VREF pin. These features reduce external component cost, board PCB size, and system power consumption.

A simple STEP/DIR interface allows for an external controller to manage the direction and step rate of the stepper motor. The internal indexer can execute high-accuracy microstepping without requiring the external controller to manage the winding current level. The indexer is capable of full step, half step, and 1/4, 1/8, 1/16, 1/32, 1/64, 1/128 and 1/256 microstepping. In addition to a standard half stepping mode, a noncircular half stepping mode is available for increased torque output at higher motor RPM.

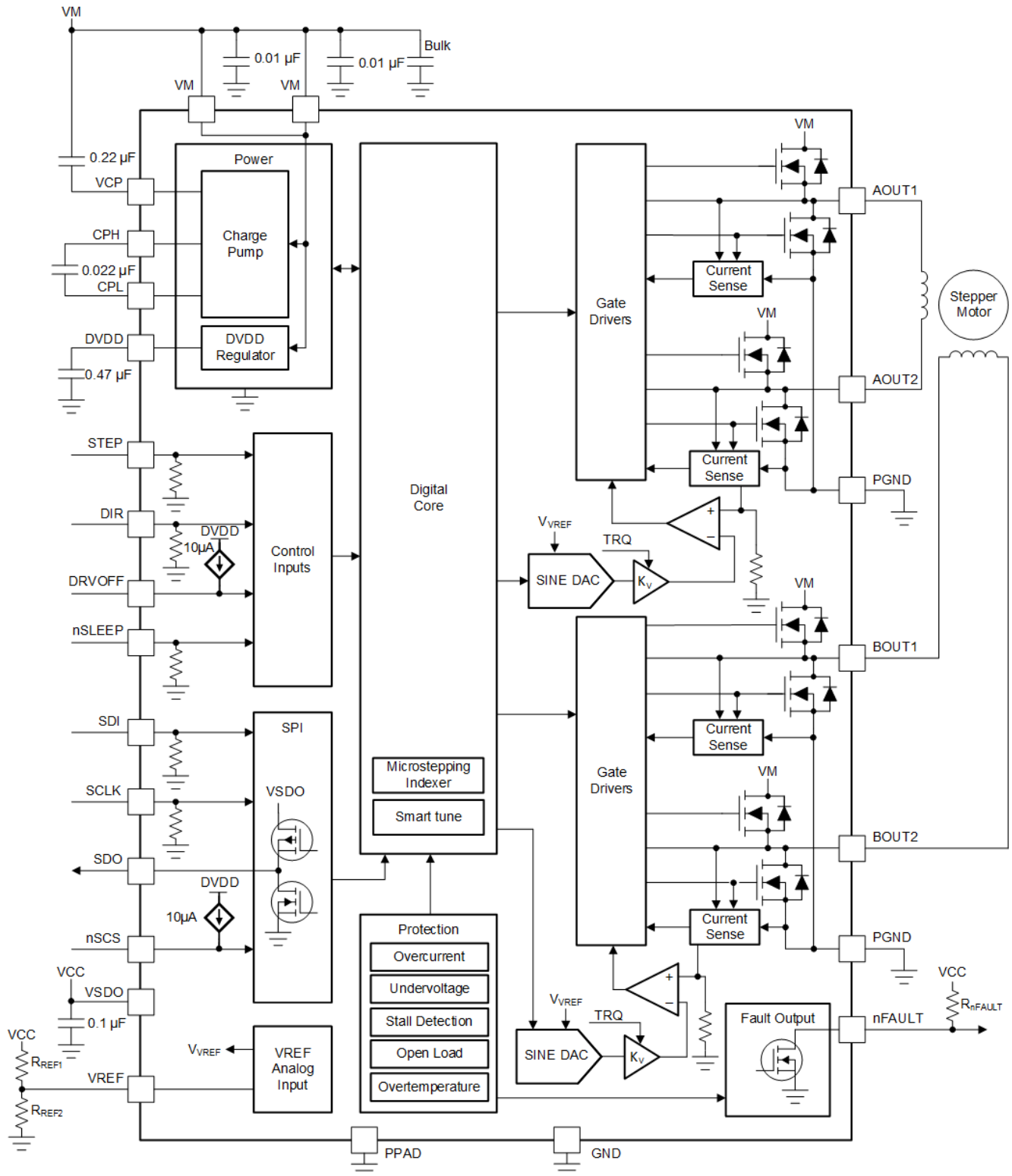
The current regulation is configurable between several decay modes. The decay mode can be selected as a slow-mixed, mixed decay, smart tune Ripple Control, or smart tune Dynamic Decay current regulation scheme. The slow-mixed decay mode uses slow decay on increasing steps and mixed decay on decreasing steps. The smart tune decay modes automatically adjust for optimal current regulation performance and compensate for motor variation and aging effects. Smart tune Ripple Control uses a variable off-time, ripple control scheme to minimize distortion of the motor winding current. Smart tune Dynamic Decay uses a fixed off-time, dynamic decay percentage scheme to minimize distortion of the motor winding current while also minimizing frequency content. In smart tune Ripple Control mode, the device can detect a motor overload stall condition or an end-of-line travel, by detecting back-emf phase shift between rising and falling current quadrants of the motor current.

The device integrates a spread spectrum clocking feature for both the internal digital oscillator and internal charge pump. This feature combined with output slew rate control minimizes the radiated emissions from the device.

A torque DAC feature allows the controller to scale the output current without needing to scale the VREF voltage reference. The torque DAC is accessed using a digital input pin which allows the controller to save system power by decreasing the motor current consumption when high output torque is not required.

A low-power sleep mode is included which allows the system to save power when not actively driving the motor.

## 6.2 Functional Block Diagram



## 6.3 Feature Description

Table 6-1 lists the recommended external components for the DRV8889-Q1 and DRV8889A-Q1 devices.

**Table 6-1. External Components**

COMPONENT	PIN 1	PIN 2	RECOMMENDED
C <sub>VM1</sub>	VM	GND	Two X7R, 0.01-μF, VM-rated ceramic capacitors
C <sub>VM2</sub>	VM	GND	Bulk, VM-rated capacitor
C <sub>VCP</sub>	VCP	VM	X7R, 0.22-μF, 16-V ceramic capacitor
C <sub>SW</sub>	CPH	CPL	X7R, 0.022-μF, VM-rated ceramic capacitor
C <sub>DVDD</sub>	DVDD	GND	X7R, 0.47-μF to 1-μF, 6.3-V ceramic capacitor
R <sub>nFAULT</sub>	VCC <sup>(1)</sup>	nFAULT	>4.7-kΩ resistor
R <sub>REF1</sub>	VREF	VCC	Resistor to limit chopping current. It is recommended that the value of parallel combination of R <sub>REF1</sub> and R <sub>REF2</sub> should be less than 50-kΩ.
R <sub>REF2</sub> (Optional)	VREF	GND	

(1) VCC is not a pin on the device, but a VCC supply voltage pullup is required for open-drain output nFAULT; nFAULT may be pulled up to DVDD

### 6.3.1 Stepper Motor Driver Current Ratings

Stepper motor drivers can be classified using three different numbers to describe the output current: peak, rms, and full-scale.

#### 6.3.1.1 Peak Current Rating

The peak current in a stepper driver is limited by the overcurrent protection trip threshold I<sub>OCP</sub>. The peak current describes any transient duration current pulse, for example when charging capacitance, when the overall duty cycle is very low. In general the minimum value of I<sub>OCP</sub> specifies the peak current rating of the stepper motor driver.

The peak current rating of the device is 2.4 A per bridge.

#### 6.3.1.2 rms Current Rating

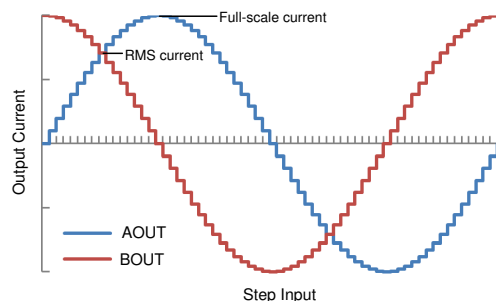
The rms (average) current is determined by the thermal considerations of the IC. The rms current is calculated based on the R<sub>DS(ON)</sub>, rise and fall time, PWM frequency, device quiescent current, and package thermal performance in a typical system at 25°C. The actual operating rms current may be higher or lower depending on heatsinking and ambient temperature.

The rms current rating of the device is 1.1 A per bridge.

#### 6.3.1.3 Full-Scale Current Rating

The full-scale current describes the top of the sinusoid current waveform while microstepping. Because the sinusoid amplitude is related to the rms current, the full-scale current is also determined by the thermal considerations of the device. The full-scale current rating is approximately  $\sqrt{2} \times I_{RMS}$ .

The full-scale current rating of the device is 1.5 A per bridge.



**Figure 6-1. Full-Scale and RMS Current**

### 6.3.2 PWM Motor Drivers

The device has drivers for two full H-bridges to drive the two windings of a bipolar stepper motor. Figure 6-2 shows a block diagram of the circuitry.

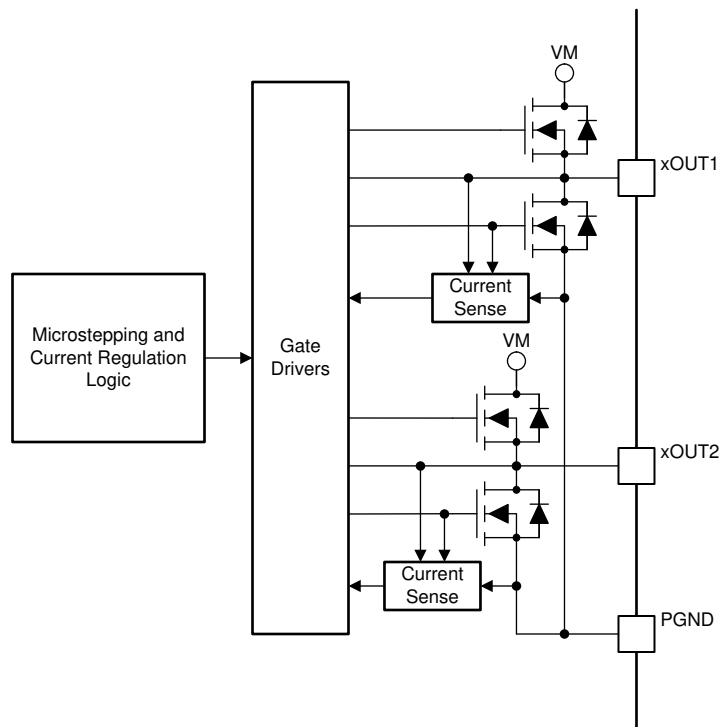


Figure 6-2. PWM Motor Driver Block Diagram

### 6.3.3 Microstepping Indexer

Built-in indexer logic in the device allows a number of different step modes. The MICROSTEP\_MODE bits in the SPI register are used to configure the step mode as shown in Table 6-2.

Table 6-2. Microstepping Settings

MICROSTEP_MODE	STEP MODE
0000b	Full step (2-phase excitation) with 100% current
0001b	Full step (2-phase excitation) with 71% current
0010b	Non-circular 1/2 step
0011b	1/2 step
0100b	1/4 step
0101b	1/8 step
0110b	1/16 step
0111b	1/32 step
1000b	1/64 step
1001b	1/128 step
1010b	1/256 step

Table 6-3 shows the relative current and step directions for full-step (71% current), 1/2 step, 1/4 step and 1/8 step operation. Higher microstepping resolutions follow the same pattern. The AOUT current is the sine of the

electrical angle and the BOUT current is the cosine of the electrical angle. Positive current is defined as current flowing from the xOUT1 pin to the xOUT2 pin while driving.

At each rising edge of the STEP input the indexer travels to the next state in the table. The direction is shown with the DIR pin logic high. If the DIR pin is logic low, the sequence is reversed.

**Note**

If the step mode is changed on the fly while stepping, the indexer advances to the next valid state for the new step mode setting at the rising edge of STEP.

**Note**

While DIR = 0 and the electrical angle is at a full step angle (45, 135, 225, or 315 degrees), two rising edge pulses on the STEP pin are required in order to advance the indexer after changing from any microstep mode to the full step mode. The first pulse will induce no change in the electrical angle, the second pulse will move the indexer to the next full step angle.

The home state is an electrical angle of 45°. This state is entered after power-up, after exiting logic undervoltage lockout, or after exiting sleep mode.

**Table 6-3. Relative Current and Step Directions**

1/8 STEP	1/4 STEP	1/2 STEP	FULL STEP 71%	AOUT CURRENT (% FULL-SCALE)	BOUT CURRENT (% FULL-SCALE)	ELECTRICAL ANGLE (DEGREES)
1	1	1		0	100	0
2				20	98	11
3	2			38	92	23
4				56	83	34
5	3	2	1	71	71	45
6				83	56	56
7	4			92	38	68
8				98	20	79
9	5	3		100	0	90
10				98	-20	101
11	6			92	-38	113
12				83	-56	124
13	7	4	2	71	-71	135
14				56	-83	146
15	8			38	-92	158
16				20	-98	169
17	9	5		0	-100	180
18				-20	-98	191
19	10			-38	-92	203
20				-56	-83	214
21	11	6	3	-71	-71	225
22				-83	-56	236
23	12			-92	-38	248
24				-98	-20	259
25	13	7		-100	0	270
26				-98	20	281

**Table 6-3. Relative Current and Step Directions (continued)**

1/8 STEP	1/4 STEP	1/2 STEP	FULL STEP 71%	AOUT CURRENT (% FULL-SCALE)	BOUT CURRENT (% FULL-SCALE)	ELECTRICAL ANGLE (DEGREES)
27	14			-92	38	293
28				-83	56	304
29	15	8	4	-71	71	315
30				-56	83	326
31	16			-38	92	338
32				-20	98	349

Table 6-4 shows the full step operation with 100% full-scale current. This stepping mode consumes more power than full-step mode with 71% current, but provides a higher torque at high motor RPM.

**Table 6-4. Full Step with 100% Current**

FULL STEP 100%	AOUT CURRENT (% FULL-SCALE)	BOUT CURRENT (% FULL-SCALE)	ELECTRICAL ANGLE (DEGREES)
1	100	100	45
2	100	-100	135
3	-100	-100	225
4	-100	100	315

Table 6-5 shows the noncircular 1/2-step operation. This stepping mode consumes more power than circular 1/2-step operation, but provides a higher torque at high motor RPM.

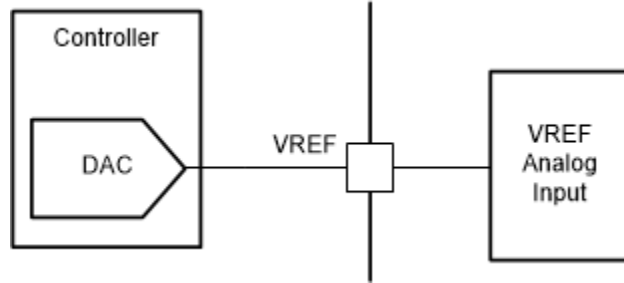
**Table 6-5. Non-Circular 1/2-Stepping Current**

NON-CIRCULAR 1/2-STEP	AOUT CURRENT (% FULL-SCALE)	BOUT CURRENT (% FULL-SCALE)	ELECTRICAL ANGLE (DEGREES)
1	0	100	0
2	100	100	45
3	100	0	90
4	100	-100	135
5	0	-100	180
6	-100	-100	225
7	-100	0	270
8	-100	100	315

### 6.3.4 Controlling VREF with an MCU DAC

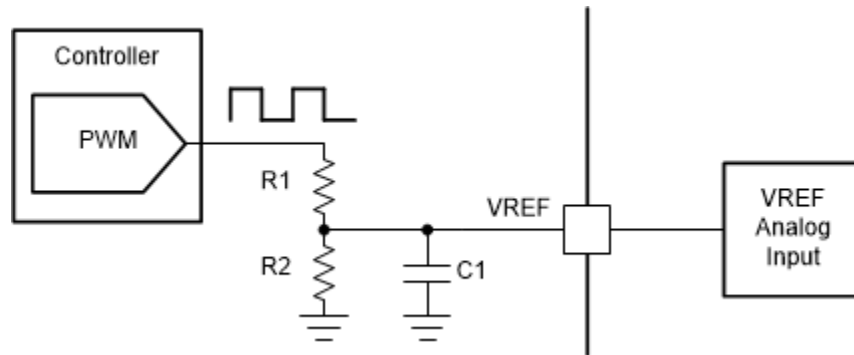
In some cases, the full-scale output current may need to be changed between many different values, depending on motor speed and loading. The voltage of the VREF pin can be adjusted in the system to change the full-scale current.

In this mode of operation, as the DAC voltage increases, the full-scale regulation current increases as well. For proper operation, the output of the DAC should not rise above 3.3 V.



**Figure 6-3. Controlling VREF with a DAC Resource**

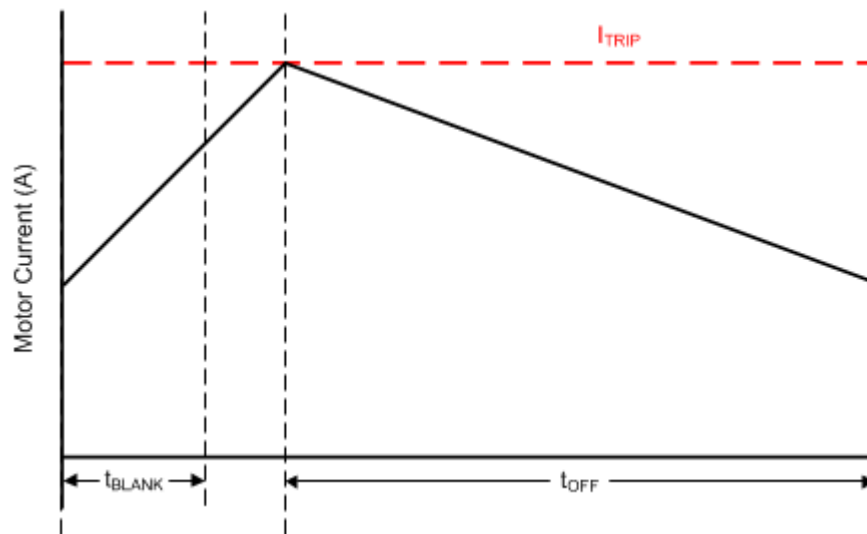
The VREF pin can also be adjusted using a PWM signal and low-pass filter. The R-C time constant for the low-pass filter should be longer than 10 times the period of the PWM signal.



**Figure 6-4. Controlling VREF With a PWM Resource**

### 6.3.5 Current Regulation

The current through the motor windings is regulated by a PWM current-regulation circuit. When an H-bridge is enabled, current rises through the winding at a rate dependent on the DC voltage, inductance of the winding, and the magnitude of the back EMF present. When the current hits the current regulation threshold, the bridge enters a decay mode for a period of time determined by the TOFF register setting and the selected decay mode to decrease the current. After the off-time expires, the bridge is re-enabled, starting another PWM cycle.



**Figure 6-5. Current Chopping Waveform**

The PWM regulation current is set by a comparator which monitors the voltage across the current sense MOSFETs in parallel with the low-side power MOSFETs. The current sense MOSFETs are biased with a reference current that is the output of a current-mode sine-weighted DAC whose full-scale reference current is set by the voltage at the VREF pin. In addition, the TRQ\_DAC register can further scale the reference current.

Use [Equation 1](#) to calculate the full-scale regulation current.

$$I_{FS} (A) = \frac{V_{REF} (V)}{K_V (V/A)} \times TRQ\_DAC (\%) = \frac{V_{REF} (V) \times TRQ\_DAC (\%)}{2.2 (V/A)} \quad (1)$$

The TRQ\_DAC is adjusted via the SPI register. [Table 6-6](#) lists the current scalar value for different inputs.

**Table 6-6. Torque DAC Settings**

TRQ_DAC	CURRENT SCALAR (TRQ)
0000b	100%
0001b	93.75%
0010b	87.5%
0011b	81.25%
0100b	75%
0101b	68.75%
0110b	62.5
0111b	56.25%
1000b	50%
1001b	43.75%
1010b	37.5%

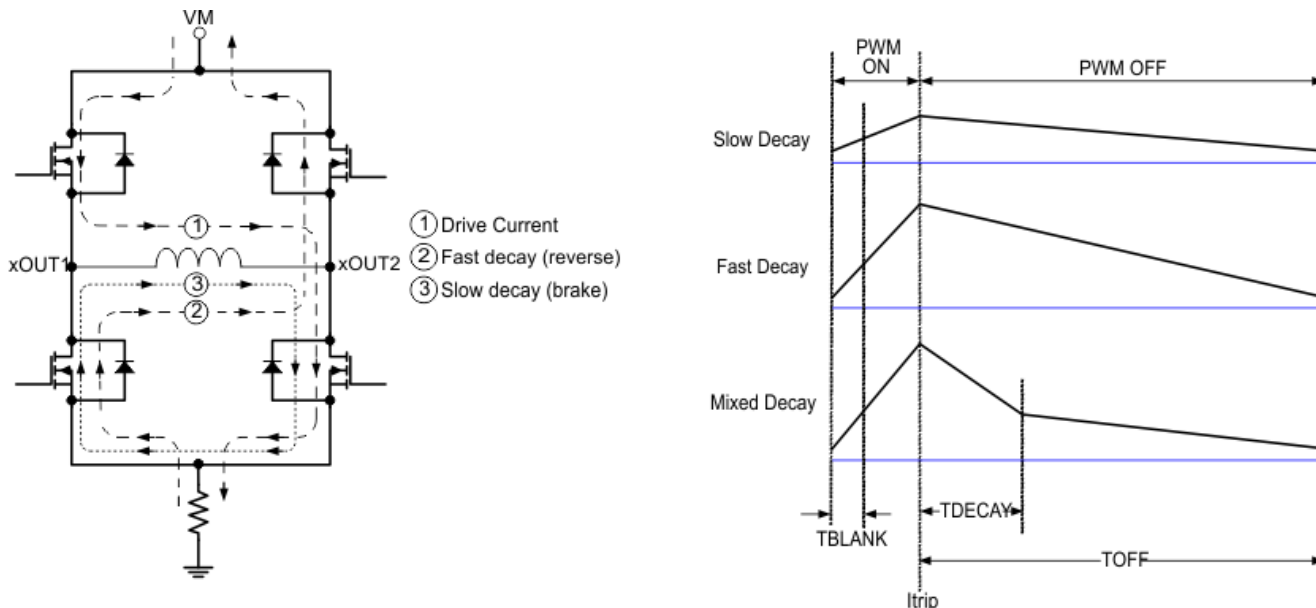
**Table 6-6. Torque DAC Settings (continued)**

TRQ_DAC	CURRENT SCALAR (TRQ)
1011b	31.25%
1100b	25%
1101b	18.75%
1110b	12.5%
1111b	6.25%

### 6.3.6 Decay Modes

During PWM current chopping, the H-bridge is enabled to drive through the motor winding until the PWM current chopping threshold is reached. This is shown in Figure 6-6, Item 1.

Once the chopping current threshold is reached, the H-bridge can operate in two different states, fast decay or slow decay. In fast decay mode, once the PWM chopping current level has been reached, the H-bridge reverses state to allow winding current to flow in a reverse direction. The opposite FETs are turned on; as the winding current approaches zero, the bridge is disabled to prevent any reverse current flow. Fast decay mode is shown in Figure 6-6, item 2. In slow decay mode, winding current is re-circulated by enabling both of the low-side FETs in the bridge. This is shown in Figure 6-6, Item 3.



**Figure 6-6. Decay Modes**

The decay mode is selected by the DECAY register as shown in Table 6-7.

**Table 6-7. Decay Mode Settings**

DECAY	INCREASING STEPS	DECREASING STEPS
000b	Slow decay	Slow decay
001b	Slow decay	Mixed decay: 30% fast
010b	Slow decay	Mixed decay: 60% fast
011b	Slow decay	Fast decay
100b	Mixed decay: 30% fast	Mixed decay: 30% fast
101b	Mixed decay: 60% fast	Mixed decay: 60% fast
110b	Smart tune Dynamic Decay	Smart tune Dynamic Decay
111b (default)	Smart tune Ripple Control	Smart tune Ripple Control

Figure 6-7 defines increasing and decreasing current. For the slow-mixed decay mode, the decay mode is set as slow during increasing current steps and mixed decay during decreasing current steps. In full step and noncircular 1/2-step operation, the decay mode corresponding to decreasing steps is always used.

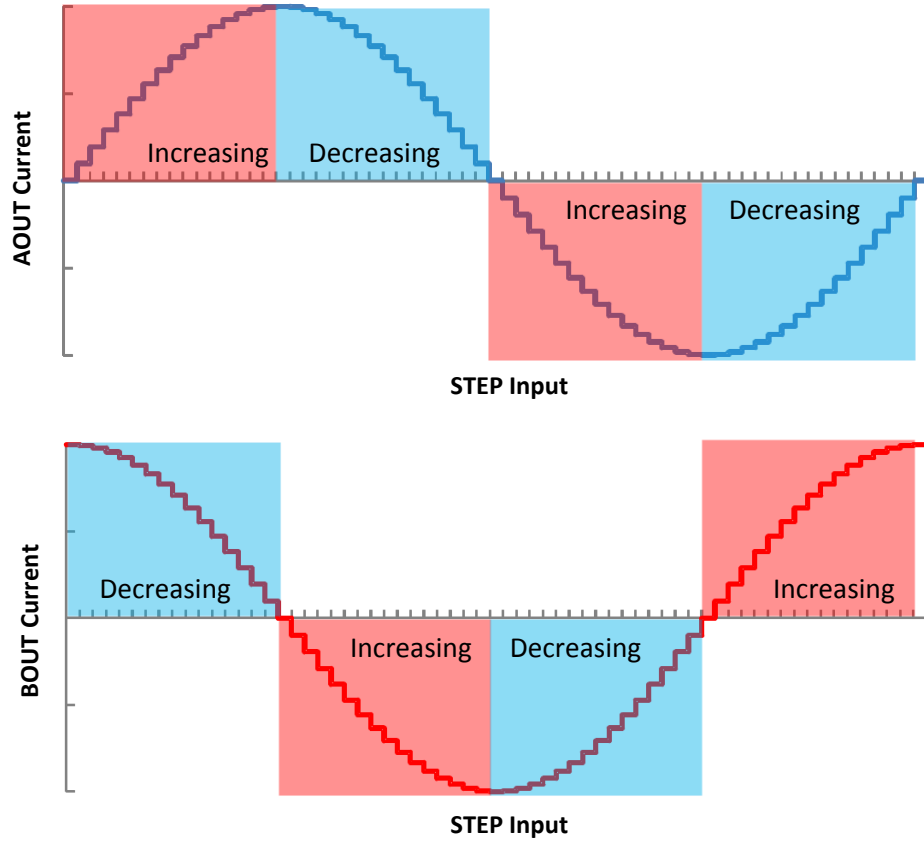
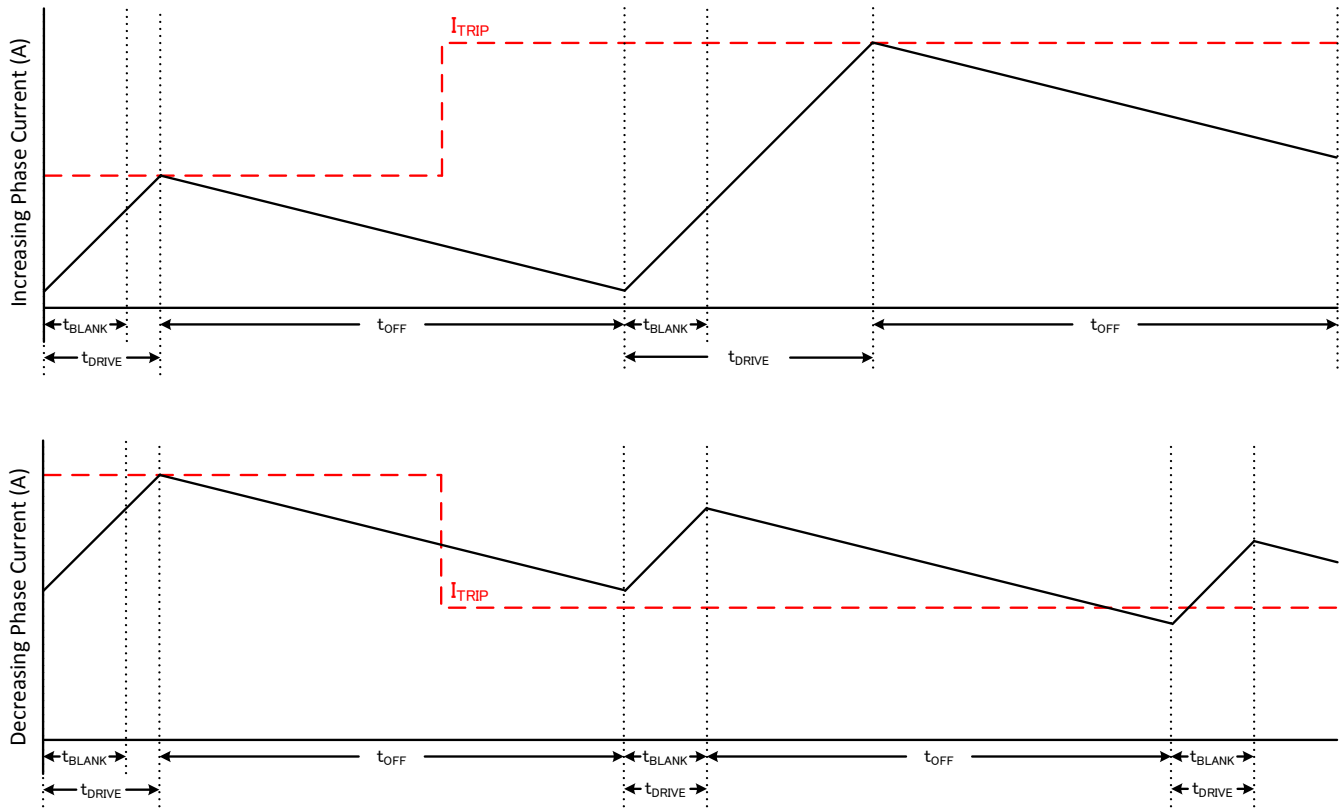


Figure 6-7. Definition of Increasing and Decreasing Steps

### 6.3.6.1 Slow Decay for Increasing and Decreasing Current



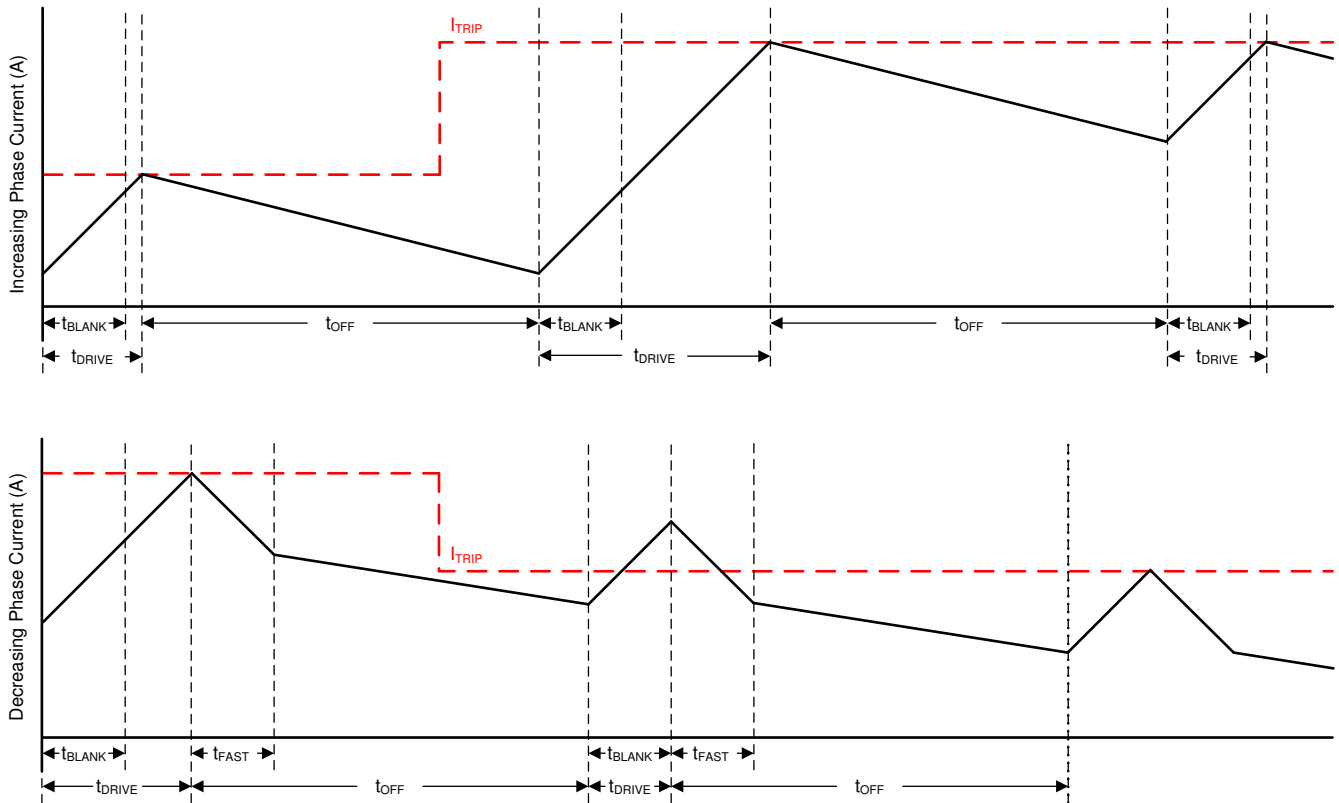
**Figure 6-8. Slow/Slow Decay Mode**

During slow decay, both of the low-side FETs of the H-bridge are turned on, allowing the current to be recirculated.

Slow decay exhibits the least current ripple of the decay modes for a given  $t_{OFF}$ . However on decreasing current steps, slow decay will take a long time to settle to the new  $I_{TRIP}$  level because the current decreases very slowly. If the current at the end of the off time is above the  $I_{TRIP}$  level, slow decay will be extended for another off time duration and so on, till the current at the end of the off time is below  $I_{TRIP}$  level.

In cases where current is held for a long time (no input in the STEP pin) or at very low stepping speeds, slow decay may not properly regulate current because no back-EMF is present across the motor windings. In this state, motor current can rise very quickly, and may require a large off-time. In some cases this may cause a loss of current regulation, and a more aggressive decay mode is recommended.

### 6.3.6.2 Slow Decay for Increasing Current, Mixed Decay for Decreasing Current

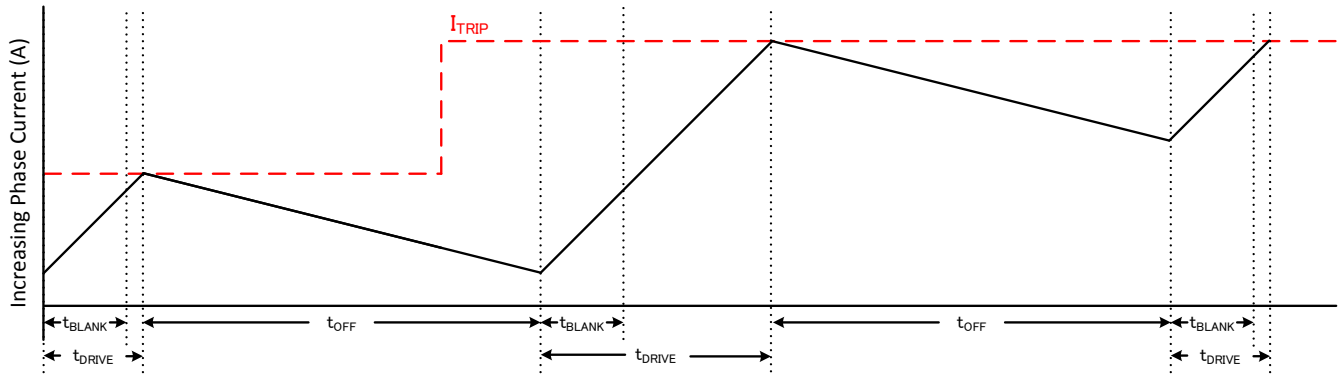


**Figure 6-9. Slow-Mixed Decay Mode**

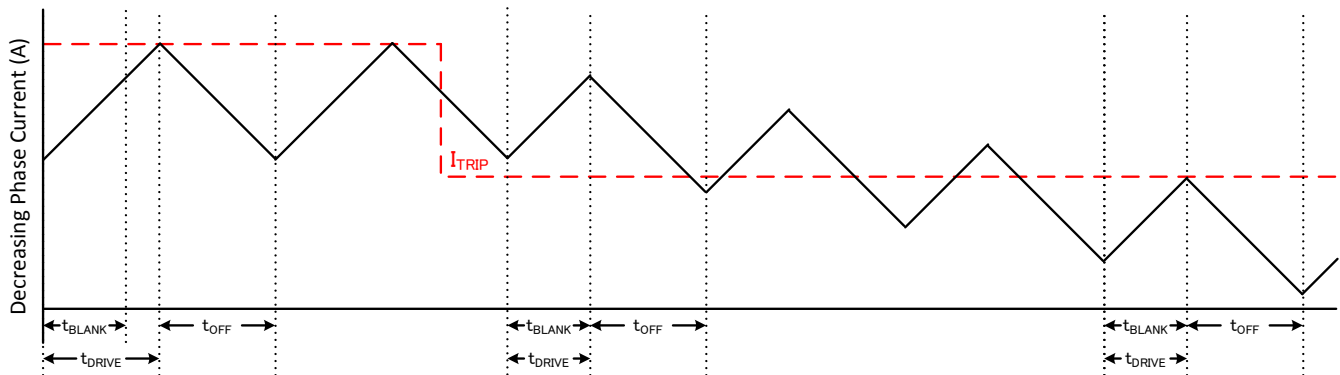
Mixed decay begins as fast decay for a time, followed by slow decay for the remainder of the  $t_{OFF}$  time. In this mode, mixed decay only occurs during decreasing current. Slow decay is used for increasing current.

This mode exhibits the same current ripple as slow decay for increasing current, because for increasing current, only slow decay is used. For decreasing current, the ripple is larger than slow decay, but smaller than fast decay. On decreasing current steps, mixed decay settles to the new  $I_{TRIP}$  level faster than slow decay.

**6.3.6.3 Mode 4: Slow Decay for Increasing Current, Fast Decay for Decreasing current**



Please note that these graphs are not the same scale;  $t_{OFF}$  is the same

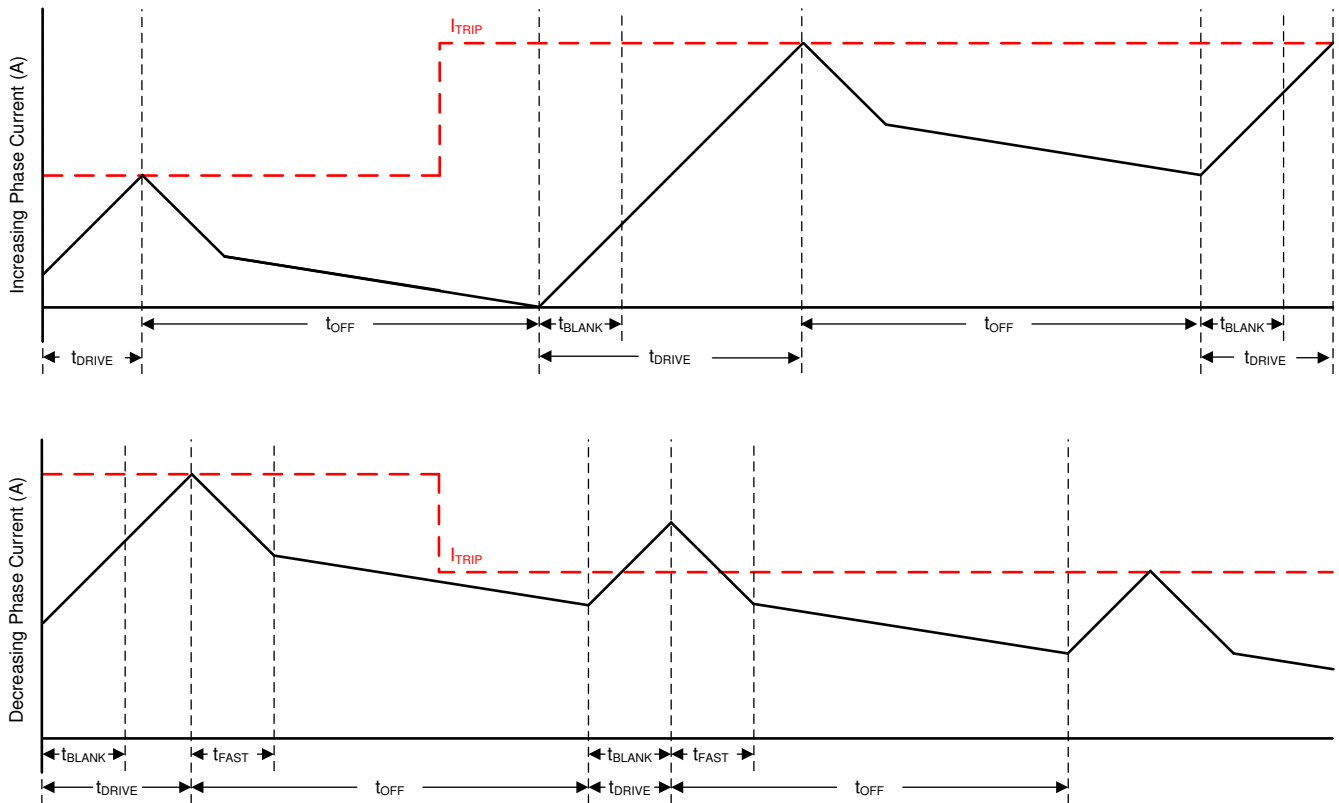


**Figure 6-10. Slow/Fast Decay Mode**

During fast decay, the polarity of the H-bridge is reversed. The H-bridge will be turned off as current approaches zero in order to prevent current flow in the reverse direction. In this mode, fast decay only occurs during decreasing current. Slow decay is used for increasing current.

Fast decay exhibits the highest current ripple of the decay modes for a given  $t_{OFF}$ . Transition time on decreasing current steps is much faster than slow decay since the current is allowed to decrease much faster.

### 6.3.6.4 Mixed Decay for Increasing and Decreasing Current



**Figure 6-11. Mixed-Mixed Decay Mode**

Mixed decay begins as fast decay for a time, followed by slow decay for the remainder of  $t_{OFF}$ . In this mode, mixed decay occurs for both increasing and decreasing current steps.

This mode exhibits ripple larger than slow decay, but smaller than fast decay. On decreasing current steps, mixed decay settles to the new  $I_{TRIP}$  level faster than slow decay.

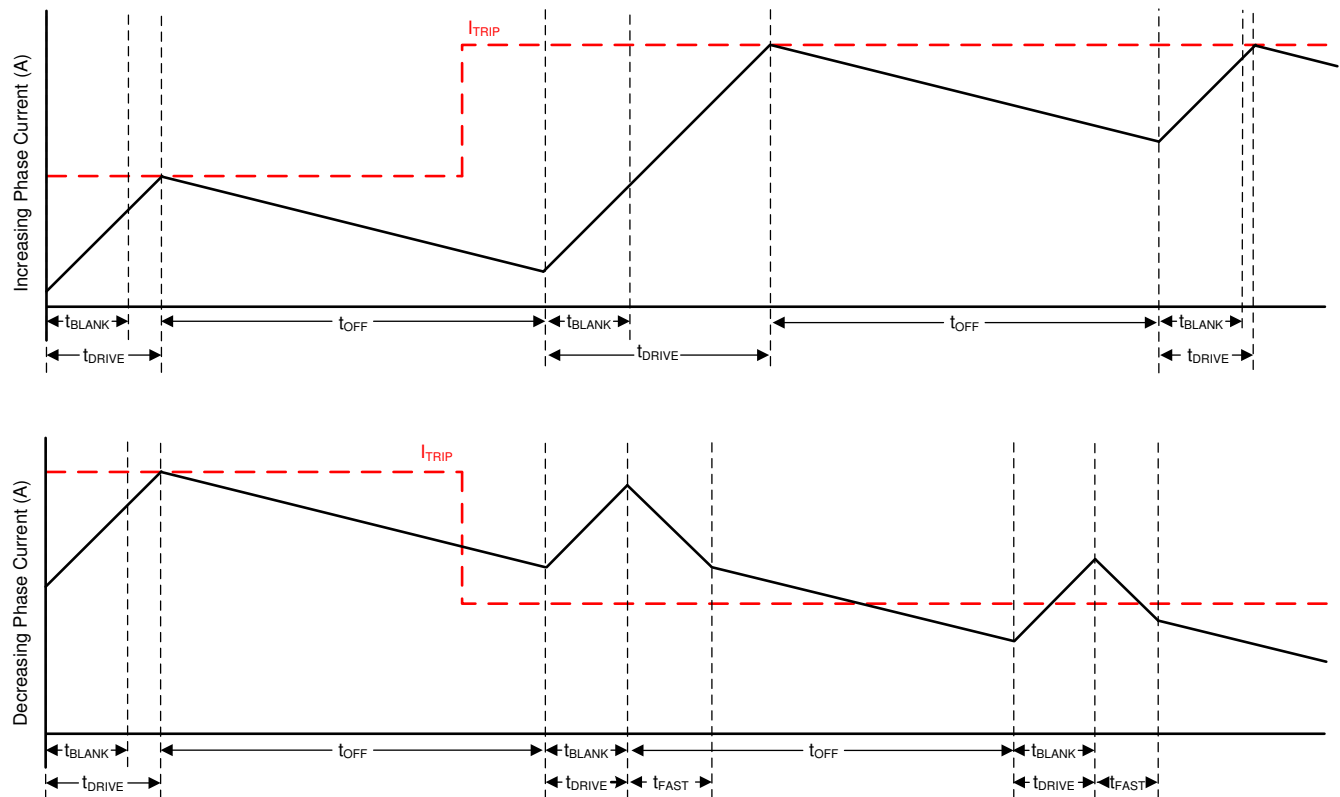
In cases where current is held for a long time (no input in the STEP pin) or at very low stepping speeds, slow decay may not properly regulate current because no back-EMF is present across the motor windings. In this state, motor current can rise very quickly, and requires an excessively large off-time. Increasing or decreasing mixed decay mode allows the current level to stay in regulation when no back-EMF is present across the motor windings.

### 6.3.6.5 Smart tune Dynamic Decay

The smart tune current regulation schemes are advanced current-regulation control methods compared to traditional fixed off-time current regulation schemes. Smart tune current regulation schemes help the stepper motor driver adjust the decay scheme based on operating factors such as the ones listed as follows:

- Motor winding resistance and inductance
- Motor aging effects
- Motor dynamic speed and load
- Motor supply voltage variation
- Motor back-EMF difference on rising and falling steps
- Step transitions
- Low-current versus high-current  $di/dt$

The device provides two different smart tune current regulation modes, named smart tune Dynamic Decay and smart tune Ripple Control.



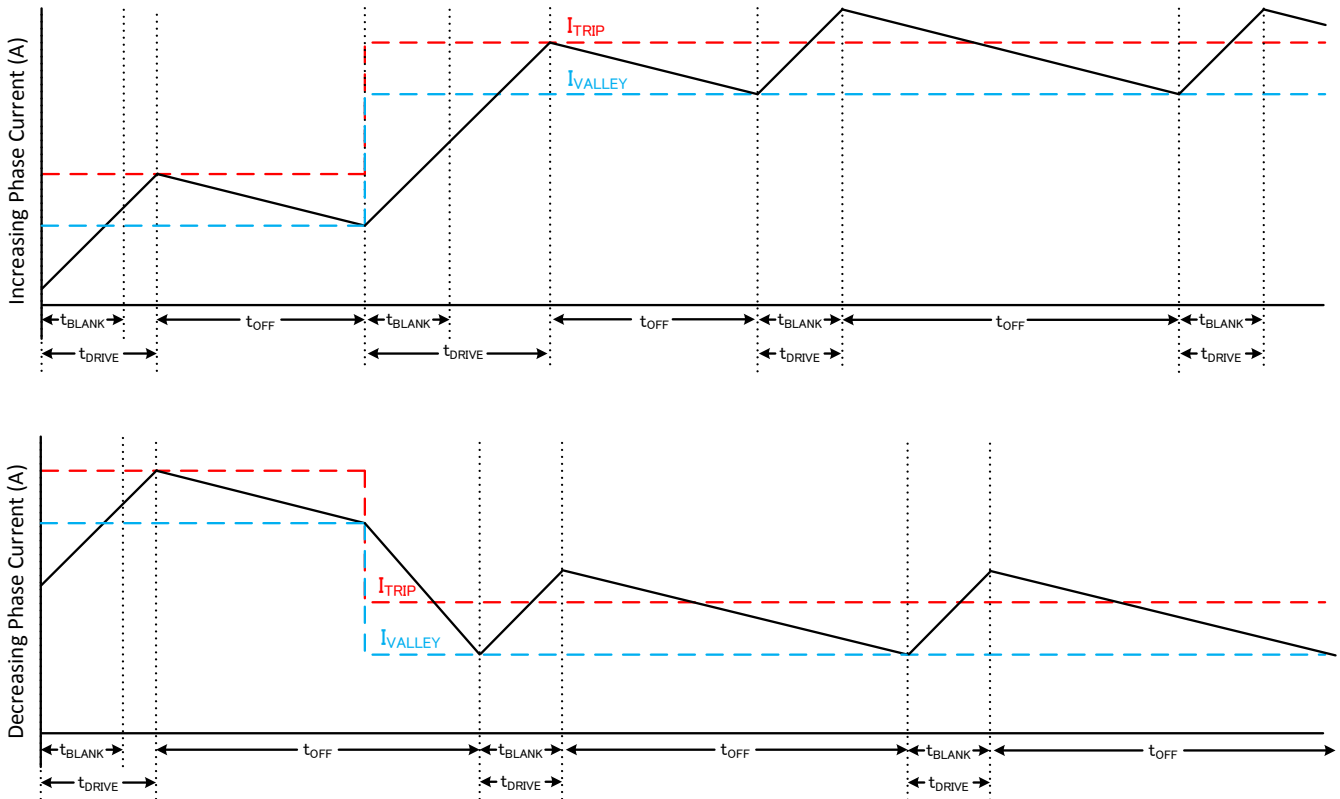
**Figure 6-12. Smart tune Dynamic Decay Mode**

Smart tune Dynamic Decay greatly simplifies the decay mode selection by automatically configuring the decay mode between slow, mixed, and fast decay. In mixed decay, smart tune dynamically adjusts the fast decay percentage of the total mixed decay time. This feature eliminates motor tuning by automatically determining the best decay setting that results in the lowest ripple for the motor.

The decay mode setting is optimized iteratively each PWM cycle. If the motor current overshoots the target trip level, then the decay mode becomes more aggressive (add fast decay percentage) on the next cycle to prevent regulation loss. If a long drive time must occur to reach the target trip level, the decay mode becomes less aggressive (remove fast decay percentage) on the next cycle to operate with less ripple and more efficiently. On falling steps, smart tune Dynamic Decay automatically switches to fast decay to reach the next step quickly.

Smart tune Dynamic Decay is optimal for applications that require minimal current ripple but want to maintain a fixed frequency in the current regulation scheme.

### 6.3.6.6 Smart tune Ripple Control



**Figure 6-13. Smart tune Ripple Control Decay Mode**

Smart tune Ripple Control operates by setting an  $I_{VALLEY}$  level alongside the  $I_{TRIP}$  level. When the current level reaches  $I_{TRIP}$ , instead of entering slow decay until the  $t_{OFF}$  time expires, the driver enters slow decay until  $I_{VALLEY}$  is reached. Slow decay operates similar to mode 1 in which both low-side MOSFETs are turned on allowing the current to recirculate. In this mode,  $t_{OFF}$  varies depending on the current level and operating conditions.

This method allows much tighter regulation of the current level increasing motor efficiency and system performance. Smart tune Ripple Control can be used in systems that can tolerate a variable off-time regulation scheme to achieve small current ripple in the current regulation.

### 6.3.7 Blanking Time

After the current is enabled in an H-bridge, the current sense comparator is ignored for a period of time ( $t_{\text{BLANK}}$ ) before enabling the current-sense circuitry. The blanking time also sets the minimum drive time of the PWM.

When the device goes into a drive phase at the end of a slow-decay phase, or goes into a slow-decay phase at the end of a drive phase, the blanking time is as shown in [Table 6-8](#).

**Table 6-8. Slow-decay to Drive Blanking Time**

DEVICE	EN_SR_BLANK	SLEW_RATE	Blanking Time ( $t_{\text{BLANK}}$ )
DRV8889A-Q1	0	All	500 ns
	1	00b	5.6 $\mu\text{s}$
		01b	2 $\mu\text{s}$
		10b	1.5 $\mu\text{s}$
		11b	860 ns
DRV8889-Q1	Not Applicable	All	500 ns

Additional blanking time is beneficial in case the stepper motor has excessive parasitic coil capacitance. For the DRV8889A-Q1, when operating the device with slow-slow or either smart tune decay modes, it is recommended to set the EN\_SR\_BLANK bit to '1'.

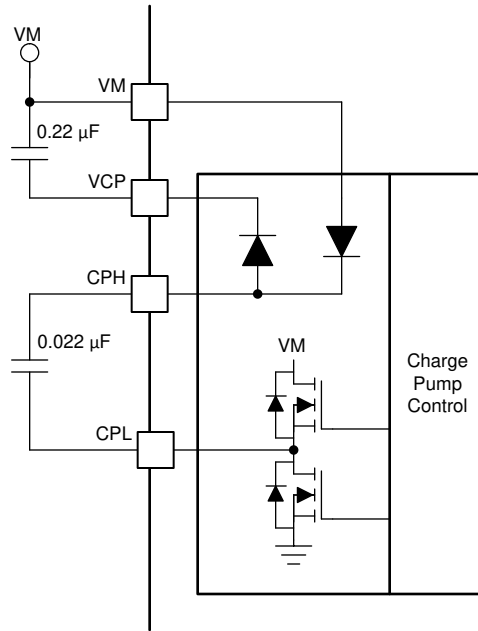
If the device goes into drive phase at the end of a fast-decay phase, the blanking time is shown in [Table 6-9](#).

**Table 6-9. Fast-decay to Drive Blanking Time**

SLEW_RATE	Blanking Time ( $t_{\text{BLANK}}$ )
00b	5.6 $\mu\text{s}$
01b	2 $\mu\text{s}$
10b	1.5 $\mu\text{s}$
11b	860 ns

### 6.3.8 Charge Pump

A charge pump is integrated to supply a high-side N-channel MOSFET gate-drive voltage. The charge pump requires a capacitor between the VM and VCP pins to act as the storage capacitor. Additionally a ceramic capacitor is required between the CPH and CPL pins to act as the flying capacitor.

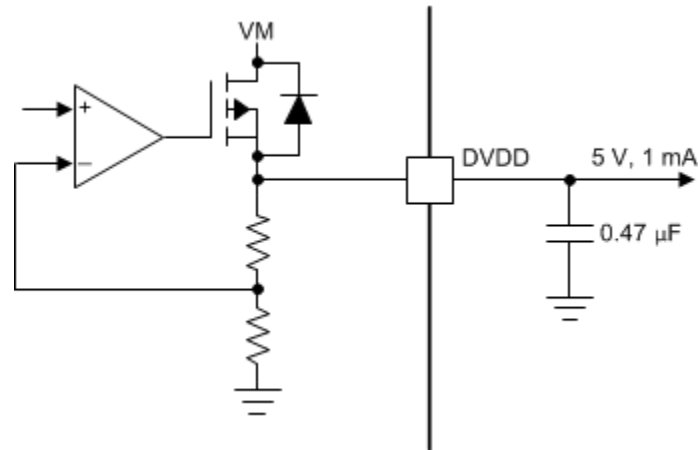


**Figure 6-14. Charge Pump Block Diagram**

### 6.3.9 Linear Voltage Regulators

A linear voltage regulator is integrated into the device. The DVDD regulator can be used to provide a reference voltage. DVDD can supply a maximum of 2 mA load. For proper operation, bypass the DVDD pin to GND using a ceramic capacitor.

The DVDD output is nominally 5-V. When the DVDD LDO current load exceeds 2 mA, the output voltage drops significantly.



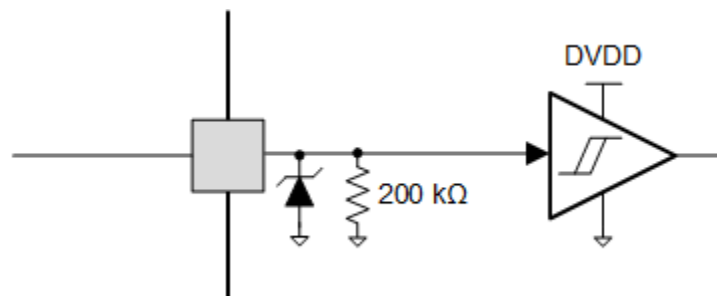
**Figure 6-15. Linear Voltage Regulator Block Diagram**

If logic level inputs must be tied permanently high, tying the input to the DVDD pin instead of an external regulator is preferred. This method saves power when the VM pin is not applied or in sleep mode: the DVDD regulator is disabled and current does not flow through the input pulldown resistors. For reference, logic level inputs have a typical pulldown of 200 kΩ.

The nSLEEP pin cannot be tied to DVDD, else the device will never exit sleep mode.

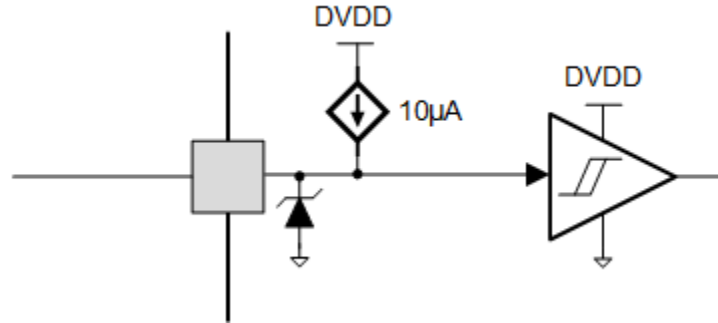
### 6.3.10 Logic Level Pin Diagrams

Figure 6-16 shows the input structure for the logic-level pins STEP, DIR, nSLEEP, SDI, and SCLK.



**Figure 6-16. Logic-Level Input Pin Diagram**

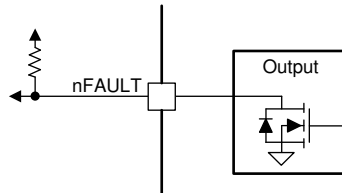
Figure 6-17 shows the input structure for the logic-level pins DRVOFF, and nSCS.



**Figure 6-17. Logic-Level with Internal Pull-up Input Pin Diagram**

### 6.3.10.1 nFAULT Pin

The nFAULT pin has an open-drain output and should be pulled up to a 5-V or 3.3-V supply. When a fault is detected, the nFAULT pin is logic low. nFAULT pin will be high after power-up. For a 5-V pullup, the nFAULT pin can be tied to the DVDD pin with a resistor. For a 3.3-V pullup, an external 3.3-V supply must be used.



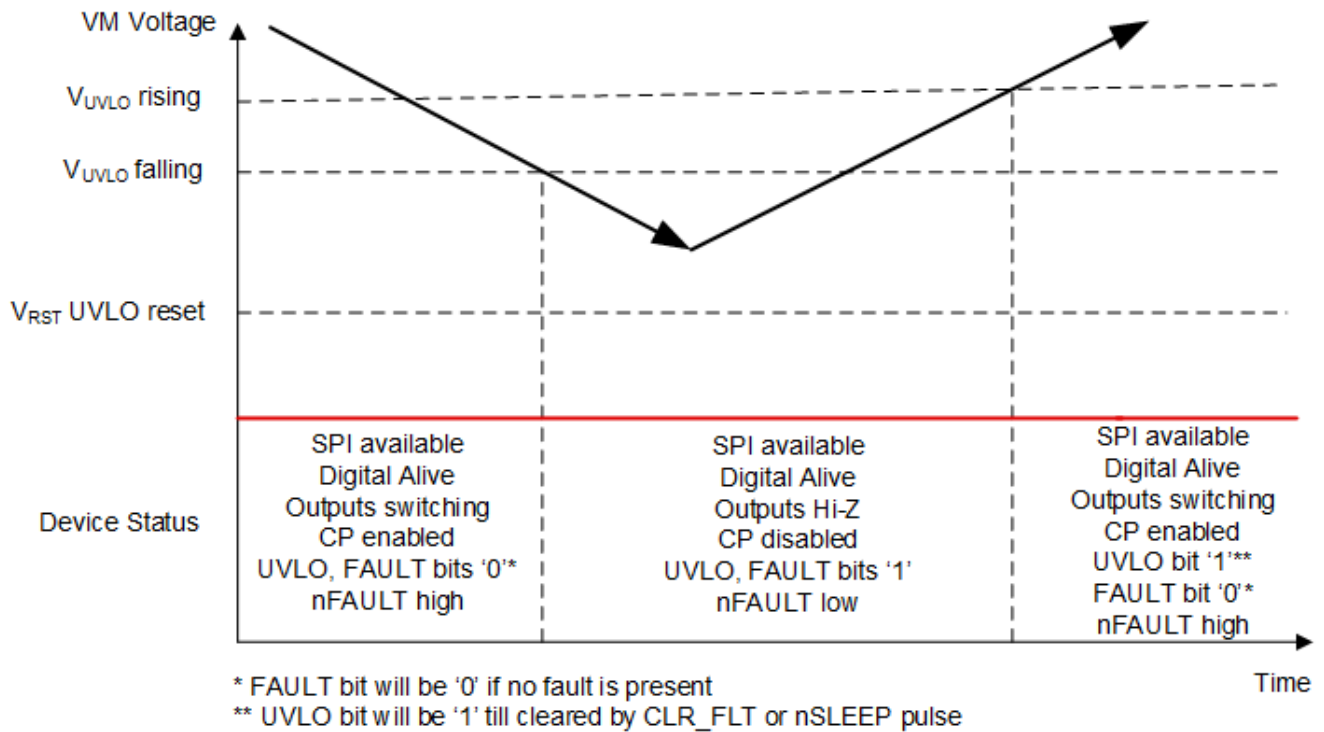
**Figure 6-18. nFAULT Pin**

### 6.3.11 Protection Circuits

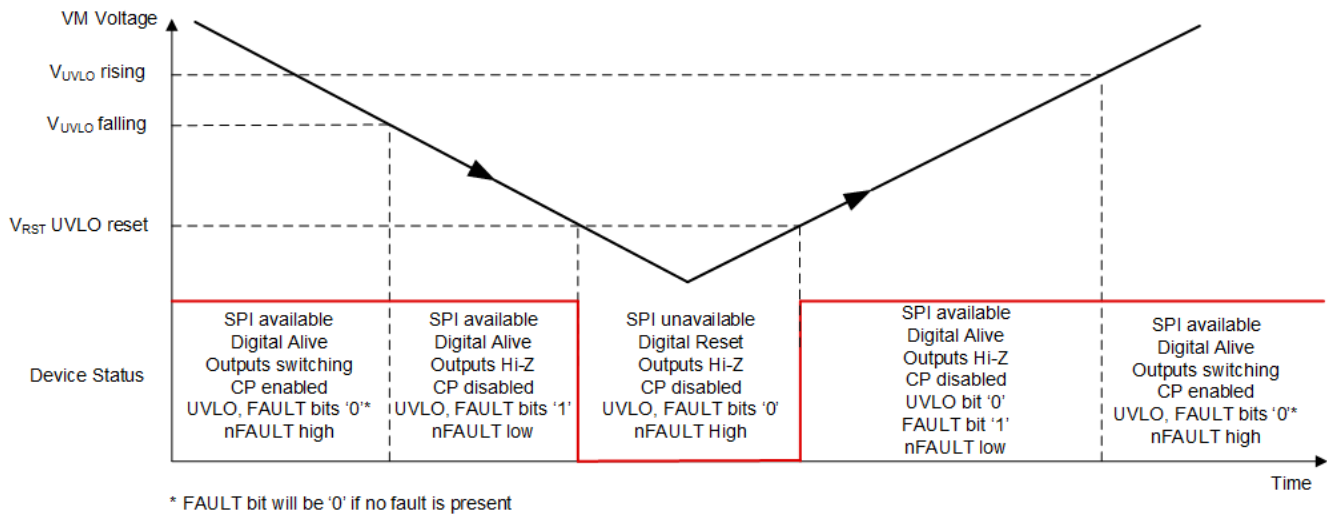
The device is fully protected against supply undervoltage, charge pump undervoltage, output overcurrent, device overtemperature, and open load events.

It provides additional diagnostics in the form of stall detection.

### 6.3.11.1 VM Undervoltage Lockout (UVLO)



**Figure 6-19. Supply Voltage Ramp Profile**



**Figure 6-20. Supply Voltage Ramp Profile**

If at any time the voltage on the VM pin falls below the UVLO falling threshold voltage, all the outputs are disabled (High-Z) and the charge pump (CP) is disabled. Normal operation resumes (motor driver and charge pump) when the VM voltage recovers above the UVLO rising threshold voltage.

When the voltage on the VM pin falls below the UVLO falling threshold voltage (4.25 V typical), but is above the VM UVLO reset voltage ( $V_{RST}$ , 3.9 V maximum), SPI communication is available, the digital core of the device is alive, the FAULT and UVLO bits are made high in the SPI registers and the nFAULT pin is driven low, as shown in Figure 6-19. From this condition, if the VM voltage recovers above the UVLO rising threshold voltage (4.35 V

typical), nFAULT pin is released (is pulled-up to the external voltage), and the FAULT bit is reset, but the UVLO bit remains latched high until cleared through the CLR\_FLT bit or an nSLEEP reset pulse.

When the voltage on the VM pin falls below the VM UVLO reset voltage ( $V_{RST}$ , 3.9 V maximum), SPI communication is unavailable, the digital core is shutdown, the FAULT and UVLO bits are low and the nFAULT pin is high. During the subsequent power-up, when the VM voltage exceeds the  $V_{RST}$  voltage, the digital core comes alive, UVLO bit stays low but the FAULT bit is made high; and the nFAULT pin is pulled low, as shown in [Figure 6-20](#). When the VM voltage exceeds the VM UVLO rising threshold, FAULT bit is reset, UVLO bit stays low and the nFAULT pin is pulled high.

### 6.3.11.2 VCP Undervoltage Lockout (CPUV)

If at any time the voltage on the VCP pin falls below the CPUV voltage, all the outputs are disabled, and the nFAULT pin is driven low. The charge pump remains active during this condition. The FAULT and CPUV bits are made high in the SPI registers. Normal operation resumes (motor-driver operation starts, nFAULT released and FAULT bit is made low) when the VCP undervoltage condition is removed. The CPUV bit remains set until it is cleared through the CLR\_FLT bit or an nSLEEP reset pulse.

### 6.3.11.3 Overcurrent Protection (OCP)

An analog current-limit circuit on each FET limits the current through the FET by removing the gate drive. If this current limit persists for longer than the  $t_{OCP}$  time, the FETs in that particular H-bridge are disabled and the nFAULT pin is driven low. The FAULT and OCP bits are latched high in the SPI registers. For xOUTx to VM short, corresponding OCP\_LSx\_x bit goes high in the DIAG Status 1 register. Similarly, for xOUTx to ground short, corresponding OCP\_HSx\_x bit goes high. For example, for AOUT1 to VM short, OCP\_LS1\_A bit goes high; and for BOUT2 to ground short, the OCP\_HS2\_B bit goes high. The charge pump remains active during this condition. The overcurrent protection can operate in two different modes: latched shutdown and automatic retry.

#### 6.3.11.3.1 Latched Shutdown (OCP\_MODE = 0b)

In this mode, after an OCP event, the relevant outputs are disabled and the nFAULT pin is driven low. Normal operation resumes after sending a CLR\_FLT command, or an nSLEEP reset pulse or a power cycling. This is the default mode for an OCP event for the device.

#### 6.3.11.3.2 Automatic Retry (OCP\_MODE = 1b)

In this mode, after an OCP event, the relevant outputs are disabled and the nFAULT pin is driven low. Normal operation resumes automatically (motor-driver operation starts, nFAULT released and FAULT bit goes low) after the  $t_{RETRY}$  time has elapsed and the fault condition is removed.

### 6.3.11.4 Open-Load Detection (OL)

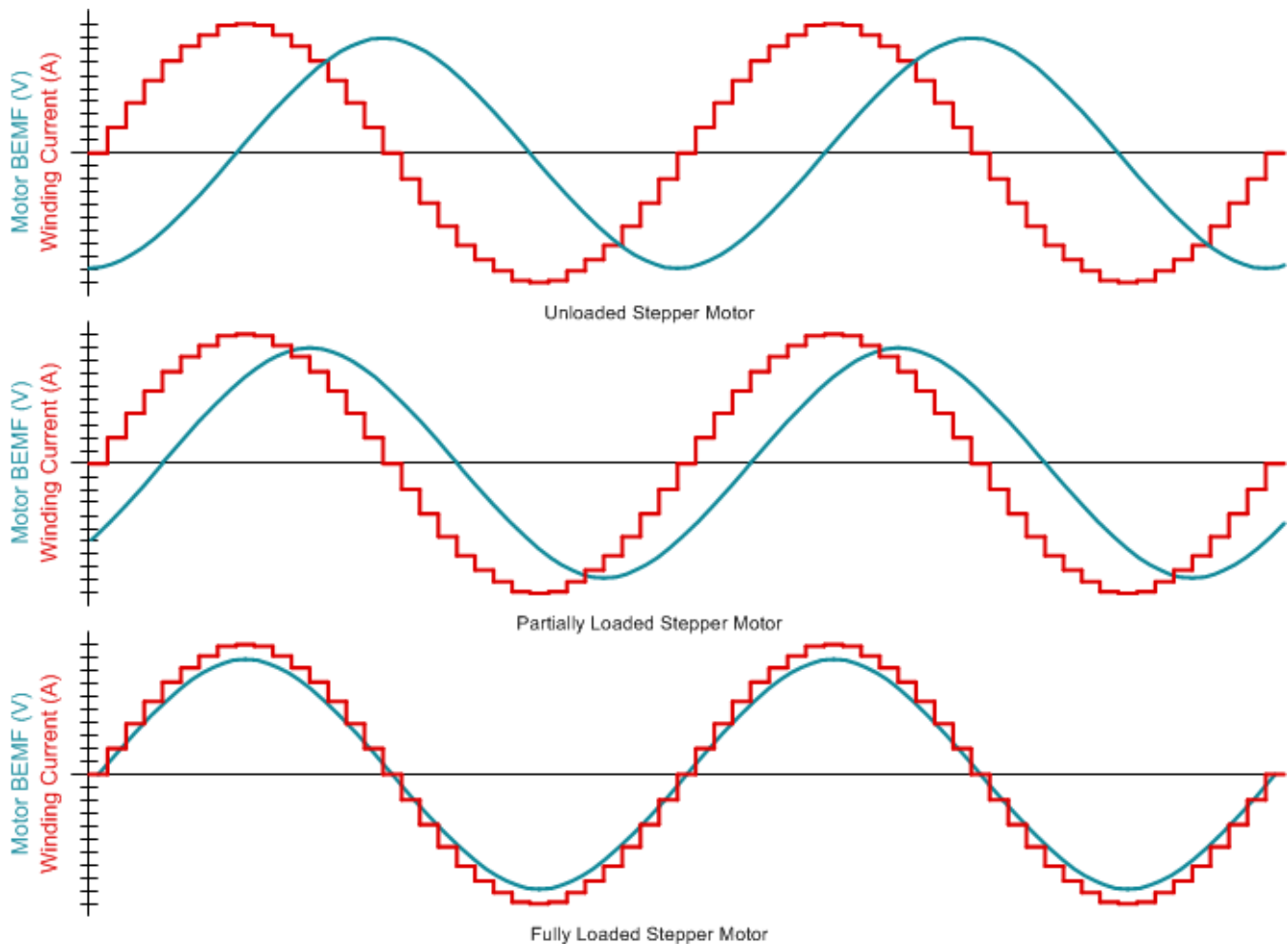
If the winding current in any coil drops below the open load current threshold ( $I_{OL}$ ) and the  $I_{TRIP}$  level set by the indexer, and if this condition persists for more than the open load detection time ( $t_{OL}$ ), an open-load condition is detected. The EN\_OL bit must be '1' to enable open load detection. When an open load fault is detected, the OL and FAULT bits are latched high in the SPI register and the nFAULT pin is driven low. If the OL\_A bit is high, it indicates an open load fault in winding A, between AOUT1 and AOUT2. Similarly, an open load fault between BOUT1 and BOUT2 causes the OL\_B bit to go high. Normal operation resumes and the nFAULT line is released when the open load condition is removed and a clear faults command has been issued either through the CLR\_FLT bit or an nSLEEP reset pulse. The fault also clears when the device is power cycled or comes out of sleep mode.

If the motor is held at a position corresponding to 0°, 90°, 180° or 270° electrical angles, for more than the open load detection time, open load fault will be flagged, as one of the coil current is zero. This situation does not arise in full-step mode, because the coil currents are never zero.

### 6.3.11.5 Stall Detection

Stepper motors have a distinct relation between the winding current, back-EMF, and mechanical torque load of the motor, as shown in [Figure 6-21](#). As motor load approaches the torque capability of the motor at a given

winding current, the back-EMF will move in phase with the winding current. By detecting back-emf phase shift between rising and falling current quadrants of the motor current, the device can detect a motor overload stall condition or an end-of-line travel.



**Figure 6-21. Stall Detection by Monitoring Motor Back-EMF**

The Stall Detection algorithm works only when the device is programmed to operate in the smart tune Ripple Control decay mode. The EN\_STL bit in CTRL5 register has to be '1' to enable stall detection. The algorithm compares the back-EMF between the rising and falling current quadrants by monitoring PWM off time and generates a value represented by the 8-bit register TRQ\_COUNT. The comparison is done in such a way that the TRQ\_COUNT value is practically independent of motor current, motor winding resistance, ambient temperature and supply voltage. Full step mode of operation is supported by this algorithm.

For a lightly loaded motor, the TRQ\_COUNT will be a non-zero value. As the motor approaches stall condition, TRQ\_COUNT will approach zero and can be used to detect stall condition. If anytime TRQ\_COUNT falls below the stall threshold (represented by the 8-bit STALL\_TH register), device will detect stall and the STALL, STL and FAULT bits are latched high in the SPI register. To indicate stall detection fault on the nFAULT pin, the STL\_REP bit in CTRL5 register has to be '1'. When the STL\_REP bit is '1', the nFAULT pin will be driven low when stall is detected. In stalled condition, the motor shaft does not spin. The motor starts to spin again when the stall condition is removed. The nFAULT line is released and the fault registers are cleared when a clear faults command has been issued either through the CLR\_FLT bit or an nSLEEP reset pulse.

TRQ\_CNT gets calculated as an average from the latest four electrical half-cycles. Once calculated, it gets updated in the SPI register within 100 ns. After the latest TRQ\_CNT is updated, it retains the value in the SPI

register for the next electrical half-cycle, after which the TRQ\_CNT is updated with a new value. The duration of the electrical half-cycle is dependent on microstepping and step-frequency. At the most, it takes two electrical cycles to detect stall.

Stall threshold can be set in two ways – either user can write the STALL\_TH bits, or let the algorithm learn the stall threshold value itself through the stall learning process. The stall learning process requires that the STL\_LRN bit in CTRL5 register is '1' and the motor is deliberately stalled for some time to allow the algorithm to learn the ideal stall threshold. The process takes 16 electrical cycles and at the end of a successful learning, loads the STALL\_TH register with the proper stall threshold bits. Also, the STL\_LRN\_OK bit goes high at the end of successful learning. It is recommended that users set the stall threshold using the stall learning process for proper stall detection. A stall threshold at one speed may not work well for another speed - therefore it is recommended to re-learn the stall threshold when the motor speed changes.

### 6.3.11.6 Thermal Shutdown (OTSD)

If the die temperature exceeds the thermal shutdown limit ( $T_{OTSD}$ ) all MOSFETs in the H-bridge are disabled, and the nFAULT pin is driven low. The charge pump is disabled in this condition. In addition, the FAULT, TF and OTS bits are latched high. This protection feature cannot be disabled. The overtemperature protection can operate in two different modes: latched shutdown and automatic recovery.

#### 6.3.11.6.1 Latched Shutdown (OTSD\_MODE = 0b)

In this mode, after a OTSD event all the outputs are disabled and the nFAULT pin is driven low. The FAULT, TF and OTS bits are latched high in the SPI register. Normal operation resumes after sending a CLR\_FLT command, or an nSLEEP reset pulse or a power cycling. This mode is the default mode for a OTSD event.

#### 6.3.11.6.2 Automatic Recovery (OTSD\_MODE = 1b)

In this mode, after a OTSD event all the outputs are disabled and the nFAULT pin is driven low. The FAULT, TF and OTS bits are latched high in the SPI register. Normal operation resumes (motor-driver operation starts, nFAULT line released and FAULT bit goes low) when the junction temperature falls below the overtemperature threshold limit minus the hysteresis ( $T_{OTSD} - T_{HYS\_OTSD}$ ). The TF and OTS bits remains latched high indicating that a thermal event occurred until a clear faults command is issued either through the CLR\_FLT bit or an nSLEEP reset pulse.

### 6.3.11.7 Overtemperature Warning (OTW)

If the die temperature exceeds the trip point of the overtemperature warning ( $T_{OTW}$ ), the OTW and TF bits are set in the SPI register. The device performs no additional action and continues to function. When the die temperature falls below the hysteresis point ( $T_{HYS\_OTW}$ ) of the overtemperature warning, the OTW and TF bits clear automatically. The OTW bit can also be configured to report on the nFAULT pin, and set the FAULT bit in the device, by setting the TW\_REP bit to 1b through the SPI registers. The charge pump remains active during this condition.

### 6.3.11.8 Undertemperature Warning (UTW)

If the die temperature falls below the trip point of the undertemperature warning ( $T_{UTW}$ ), the UTW and TF bits are set in the SPI register. The device performs no additional action and continues to function. When the die temperature exceeds the hysteresis point ( $T_{HYS\_UTW}$ ) of the undertemperature warning, the UTW and TF bits clear automatically. The UTW bit can also be configured to report on the nFAULT pin, and set the FAULT bit in the device, by setting the TW\_REP bit to 1b through the SPI registers. The charge pump remains active during this condition.

**Table 6-10. Fault Condition Summary**

FAULT	CONDITION	CONFIGURATION	ERROR REPORT	H-BRIDGE	CHARGE PUMP	INDEXER	LOGIC	RECOVERY
VM undervoltage (UVLO)	$VM < V_{UVLO}$ (max 4.35 V)	—	nFAULT / SPI	Disabled	Disabled	Disabled	Reset ( $V_{VM} < 3.9$ V)	Automatic: $VM > V_{UVLO}$ (max 4.45 V)
VCP undervoltage (CPUV)	$VCP < V_{CPUV}$ (typ VM + 2.25 V)	—	nFAULT / SPI	Disabled	Operating	Operating	Operating	$VCP > V_{CPUV}$ (typ VM + 2.7 V)

**Table 6-10. Fault Condition Summary (continued)**

FAULT	CONDITION	CONFIGURATION	ERROR REPORT	H-BRIDGE	CHARGE PUMP	INDEXER	LOGIC	RECOVERY
Overcurrent (OCP)	$I_{OUT} > I_{OCP}$ (min 2.4 A)	OCP_MOD E = 0b	nFAULT / SPI	Disabled	Operating	Operating	Operating	Latched: CLR_FLT / nSLEEP
		OCP_MOD E = 1b	nFAULT / SPI	Disabled	Operating	Operating	Operating	Automatic retry: $t_{RETRY}$
Open Load (OL)	No load detected	EN_OL = 1b	nFAULT / SPI	Operating	Operating	Operating	Operating	Report only
Stall Detection (STALL)	Stall / stuck motor	STL_REP = 0b	SPI	Operating	Operating	Operating	Operating	CLR_FLT / nSLEEP
		STL_REP = 1b	nFAULT / SPI	Operating	Operating	Operating	Operating	
Overtemperature Warning (OTW)	$T_J > T_{OTW}$	TW_REP = 1b	nFAULT / SPI	Operating	Operating	Operating	Operating	Automatic: $T_J <$ $T_{OTW} - T_{HYS\_OTW}$
		TW_REP = 0b	SPI	Operating	Operating	Operating	Operating	
Undertemperature Warning (UTW)	$T_J < T_{UTW}$	TW_REP = 1b	nFAULT / SPI	Operating	Operating	Operating	Operating	Automatic: $T_J >$ $T_{UTW} + T_{HYS\_UTW}$
		TW_REP = 0b	SPI	Operating	Operating	Operating	Operating	
Thermal Shutdown (OTSD)	$T_J > T_{OTSD}$	OTSD_MO DE = 0b	nFAULT / SPI	Disabled	Disabled	Operating	Operating	Latched: CLR_FLT / nSLEEP
		OTSD_MO DE = 1b	SPI	Disabled	Disabled	Operating	Operating	Automatic: $T_J <$ $T_{OTSD} - T_{HYS\_OTSD}$

## 6.4 Device Functional Modes

### 6.4.1 Sleep Mode ( $nSLEEP = 0$ )

The device state is managed by the nSLEEP pin. When the nSLEEP pin is low, the device enters a low-power sleep mode. In sleep mode, all the internal MOSFETs are disabled, the DVDD regulator is disabled, the charge pump is disabled, and the SPI is disabled. The  $t_{SLEEP}$  time must elapse after a falling edge on the nSLEEP pin before the device enters sleep mode. The device is brought out of sleep automatically if the nSLEEP pin is brought high. The  $t_{WAKE}$  time must elapse before the device is ready for inputs.

### 6.4.2 Disable Mode ( $nSLEEP = 1$ , $DRVOFF = 1$ )

The DRVOFF pin is used to enable or disable the half bridges in the device. When the DRVOFF pin is high, the output drivers are disabled in the Hi-Z state.

The DIS\_OUT bit can also be used to disable the output drivers. When the DIS\_OUT bit is '1', the output drivers are disabled in the Hi-Z state. DIS\_OUT is OR'ed with DRVOFF pin.

**Table 6-11. Conditions to Enable or Disable Output Drivers**

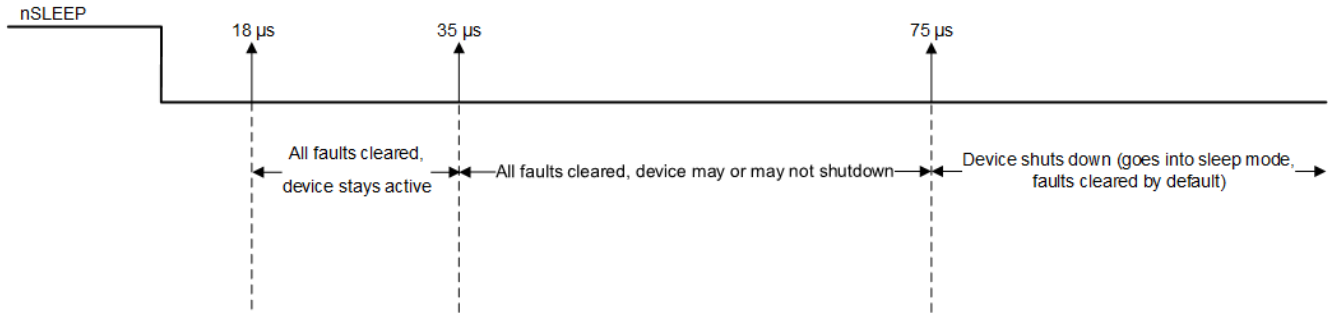
nSLEEP	DRVOFF	DIS_OUT	H-BRIDGE
0	Don't Care	Don't Care	Disabled
1	0	0	Operating
1	0	1	Disabled
1	1	0	Disabled
1	1	1	Disabled

### 6.4.3 Operating Mode ( $nSLEEP = 1$ , $DRVOFF = 0$ )

When the nSLEEP pin is high, the DRVOFF pin is low, and  $VM > UVLO$ , the device enters the active mode. The  $t_{WAKE}$  time must elapse before the device is ready for inputs.

### 6.4.4 nSLEEP Reset Pulse

In addition to the CLR\_FLT bit in the SPI register, a latched fault can be cleared through a quick nSLEEP pulse. This pulse width must be greater than 18  $\mu$ s and shorter than 35  $\mu$ s. If nSLEEP is low for longer than 35  $\mu$ s but less than 75  $\mu$ s, the faults are cleared and the device may or may not shutdown, as shown in the timing diagram (see Figure 6-22). This reset pulse resets any SPI faults and does not affect the status of the charge pump or other functional blocks.



**Figure 6-22. nSLEEP Reset Pulse**

Table 6-12 lists a summary of the functional modes.

**Table 6-12. Functional Modes Summary**

CONDITION		CONFIGURATION	H-BRIDGE	DVDD Regulator	CHARGE PUMP	INDEXER	LOGIC
Sleep mode	4.5 V < VM < 45 V	nSLEEP pin = 0	Disabled	Disabled	Disabled	Disabled	Disabled
Operating	4.5 V < VM < 45 V	nSLEEP pin = 1 DRVOFF pin = 0	Operating	Operating	Operating	Operating	Operating
Disabled	4.5 V < VM < 45 V	nSLEEP pin = 1 DRVOFF pin = 1	Disabled	Operating	Operating	Operating	Operating

Table 6-13 lists a summary of the diagnostic coverage in various functional modes.

**Table 6-13. Diagnostic Coverage in Various Functional Modes**

CONDITION	UVLO	CPUV	OCP	OL	OTSD	OTW/UTW
Sleep mode	Disabled	Disabled	Disabled	Disabled	Disabled	Disabled
Operating, motor is running	Enabled	Enabled	Enabled	Enabled	Enabled	Enabled
Operating, motor is held at a fixed position	Enabled	Enabled	Enabled	Enabled	Enabled	Enabled
Disabled	Enabled	Enabled	Disabled	Disabled	Enabled	Enabled

## 6.5 Programming

### 6.5.1 Serial Peripheral Interface (SPI) Communication

The device SPI has full duplex, 4-wire synchronous communication. This section describes the SPI protocol, the command structure, and the control and status registers. The device can be connected with the MCU in the following configurations:

- One peripheral device
- Multiple peripheral devices in parallel connection
- Multiple peripheral devices in series (daisy chain) connection

#### 6.5.1.1 SPI Format

The SDI input data word is 16 bits long and consists of the following format:

- 1 read or write bit, W (bit 14)
- 5 address bits, A (bits 13 through 9)
- 8 data bits, D (bits 7 through 0)

The SDO output-data word is 16 bits long and the first 8 bits make up the Status Register (S1). The Report word (R1) is the content of the register being accessed.

For a write command (W0 = 0), the response word on the SDO pin is the data currently in the register being written to.

For a read command (W0 = 1), the response word is the data currently in the register being read.

**Table 6-14. SDI Input Data Word Format**

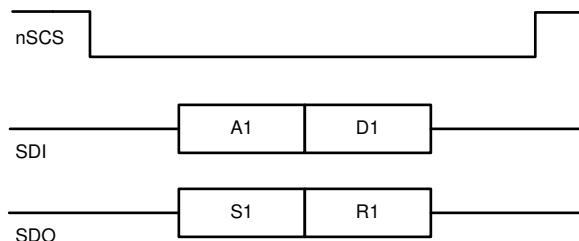
R/W		ADDRESS					DON'T CARE	DATA							
B15	B14	B13	B12	B11	B10	B9	B8	B7	B6	B5	B4	B3	B2	B1	B0
0	W0	A4	A3	A2	A1	A0	X	D7	D6	D5	D4	D3	D2	D1	D0

**Table 6-15. SDO Output Data Word Format**

STATUS								REPORT							
B15	B14	B13	B12	B11	B10	B9	B8	B7	B6	B5	B4	B3	B2	B1	B0
1	1	UVLO	CPUV	OCV	STL	TF	OL	D7	D6	D5	D4	D3	D2	D1	D0

**6.5.1.2 SPI for a Single peripheral Device**

The SPI is used to set device configurations, operating parameters, and read out diagnostic information. The SPI operates in peripheral mode. The SPI input-data (SDI) word consists of a 16-bit word, with 8 bits command and 8 bits of data. The SPI output data (SDO) word consists of 8 bits of status register with fault status indication and 8 bits of register data. [Figure 6-23](#) shows the data sequence between the MCU and the SPI peripheral driver.

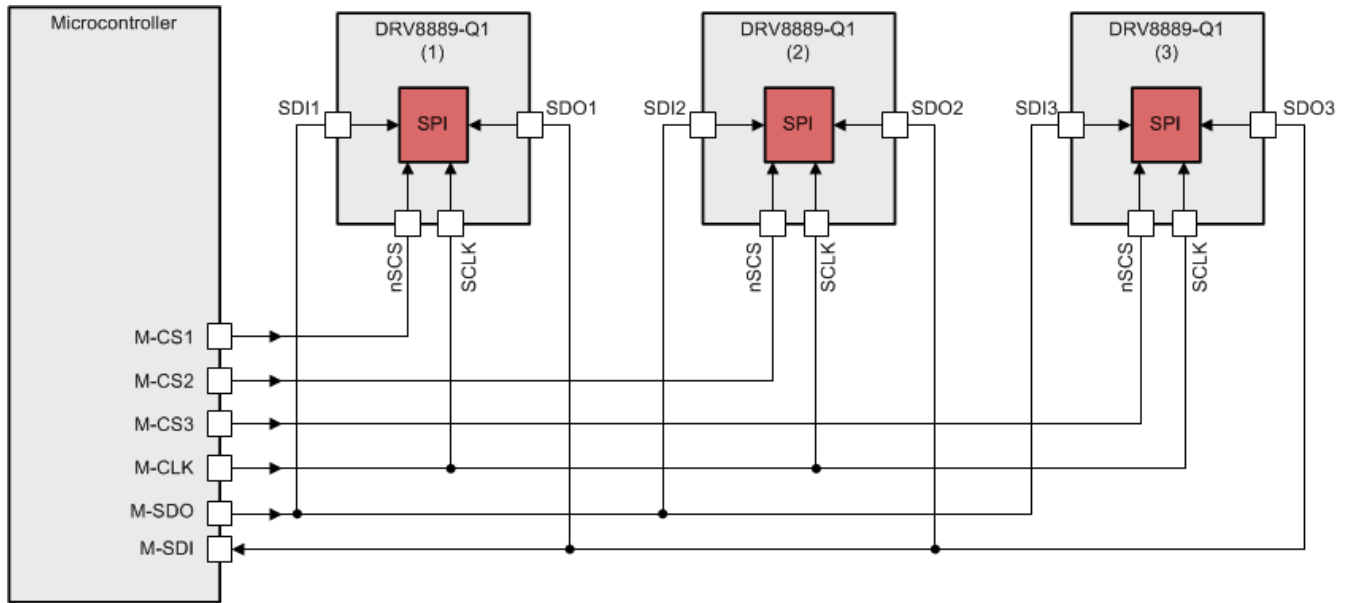


**Figure 6-23. SPI Transaction Between MCU and the device**

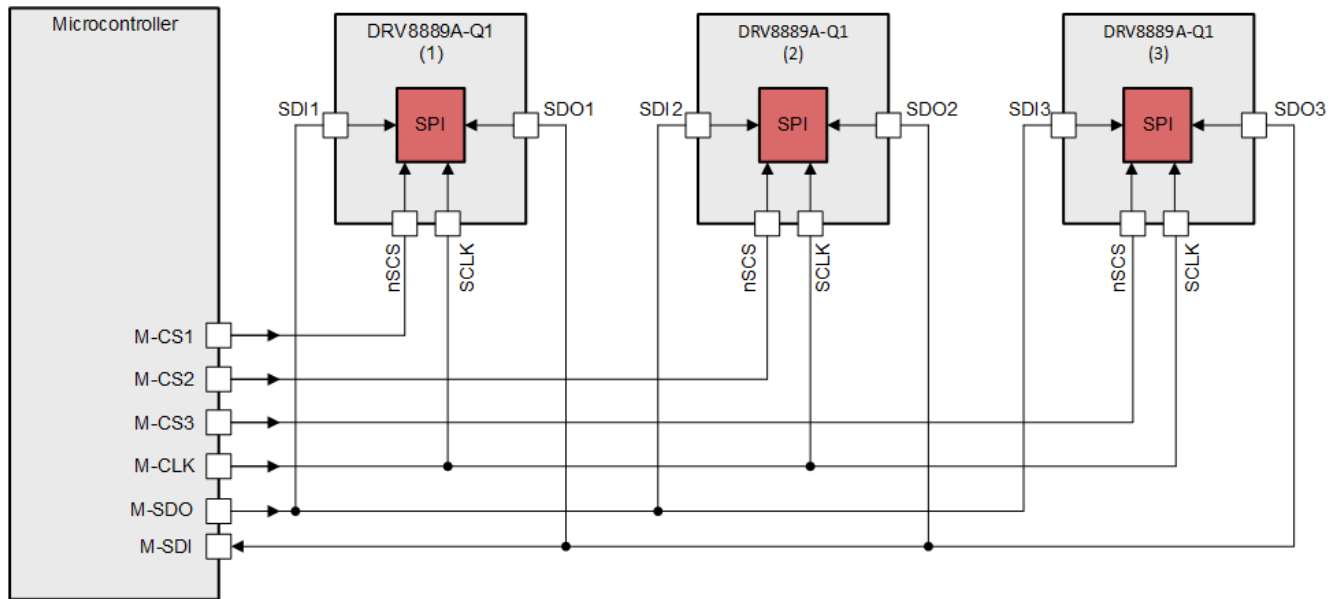
A valid frame must meet the following conditions:

- The SCLK pin must be low when the nSCS pin goes low and when the nSCS pin goes high.
- The nSCS pin should be taken high for at least 500 ns between frames.
- When the nSCS pin is asserted high, any signals at the SCLK and SDI pins are ignored, and the SDO pin is in the high-impedance state (Hi-Z).
- Full 16 SCLK cycles must occur.
- Data is captured on the falling edge of the clock and data is driven on the rising edge of the clock.
- The most-significant bit (MSB) is shifted in and out first.
- If the data word sent to SDI pin is less than 16 bits or more than 16 bits, a frame error occurs and the data word is ignored.
- For a write command, the existing data in the register being written to is shifted out on the SDO pin following the 8-bit command data.

### 6.5.1.3 SPI for Multiple peripheral Devices in Parallel Configuration



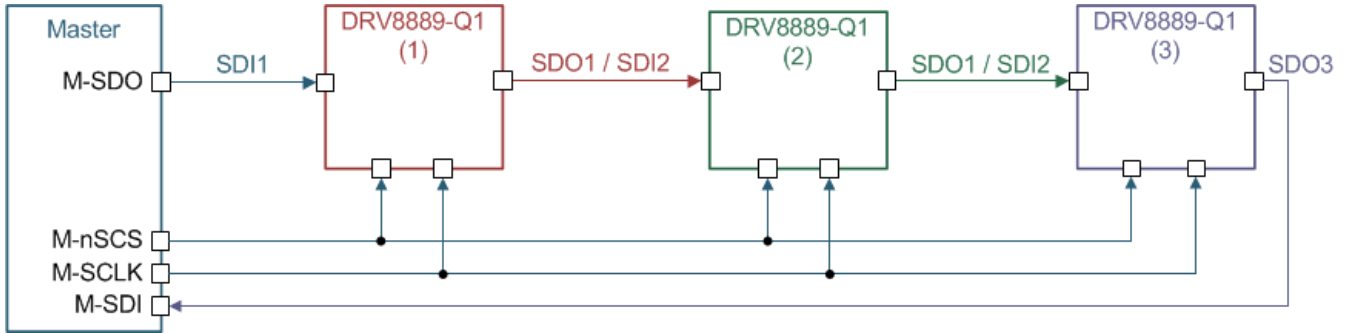
**Figure 6-24. Three DRV8889-Q1 Devices Connected in Parallel Configuration**



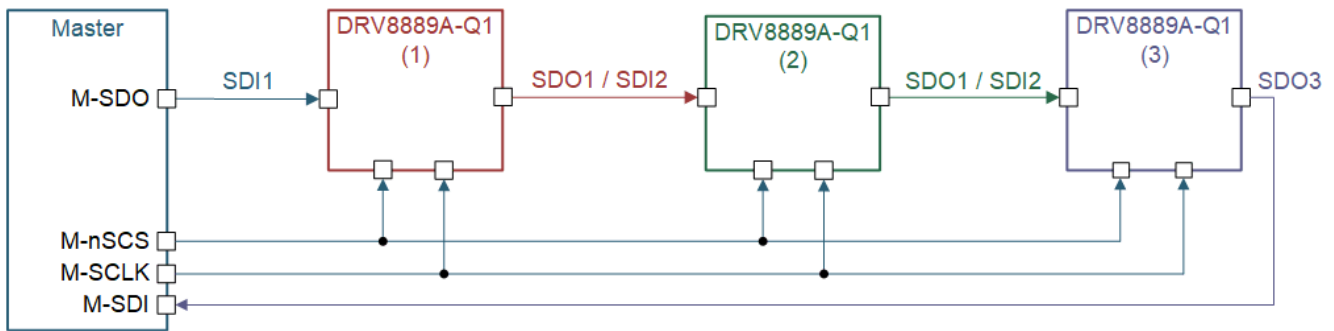
**Figure 6-25. Three DRV8889A-Q1 Devices Connected in Parallel Configuration**

### 6.5.1.4 SPI for Multiple peripheral Devices in Daisy Chain Configuration

The device can be connected in a daisy chain configuration to keep GPIO ports available when multiple devices are communicating to the same MCU. [Figure 6-27](#) shows the topology when three devices are connected in series.

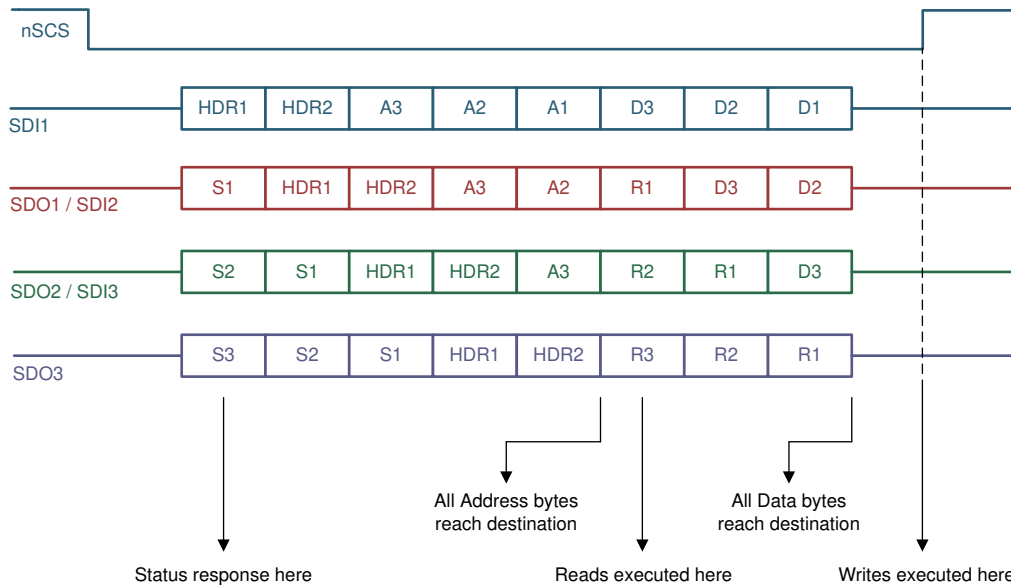


**Figure 6-26. Three DRV8889-Q1 Devices Connected in Daisy Chain**



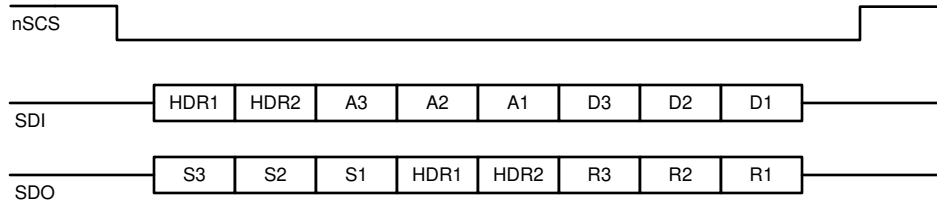
**Figure 6-27. Three DRV8889A-Q1 Devices Connected in Daisy Chain**

The first device in the chain receives data from the MCU in the following format for 3-device configuration: 2 bytes of header (HDRx) followed by 3 bytes of address (Ax) followed by 3 bytes of data (Dx).



**Figure 6-28. SPI Frame With Three Devices**

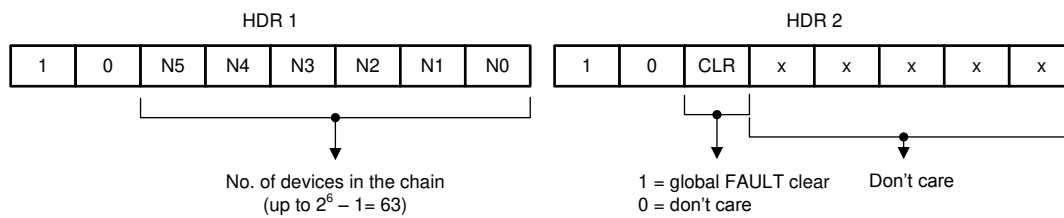
After the data has been transmitted through the chain, the MCU receives the data string in the following format for 3-device configuration: 3 bytes of status (Sx) followed by 2 bytes of header followed by 3 bytes of report (Rx).



**Figure 6-29. SPI Data Sequence for Three Devices**

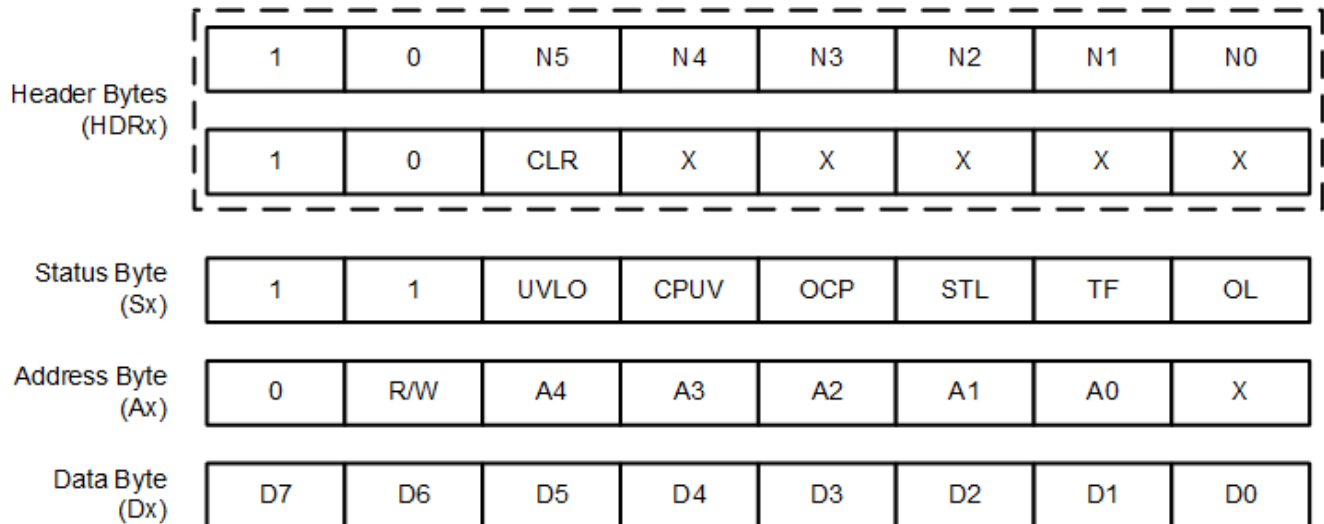
The header bytes contain information of the number of devices connected in the chain, and a global clear fault command that will clear the fault registers of all the devices on the rising edge of the chip select (nSCS) signal. Header values N5 through N0 are 6 bits dedicated to show the number of devices in the chain. Up to 63 devices can be connected in series for each daisy chain connection.

The 5 LSBs of the HDR2 register are don't care bits that can be used by the MCU to determine integrity of the daisy chain connection. Header bytes must start with 1 and 0 for the two MSBs.



**Figure 6-30. Header Bytes**

The status byte provides information about the fault status register for each device in the daisy chain so that the MCU does not have to initiate a read command to read the fault status from any particular device. This keeps additional read commands for the MCU and makes the system more efficient to determine fault conditions flagged in a device. Status bytes must start with 1 and 1 for the two MSBs.



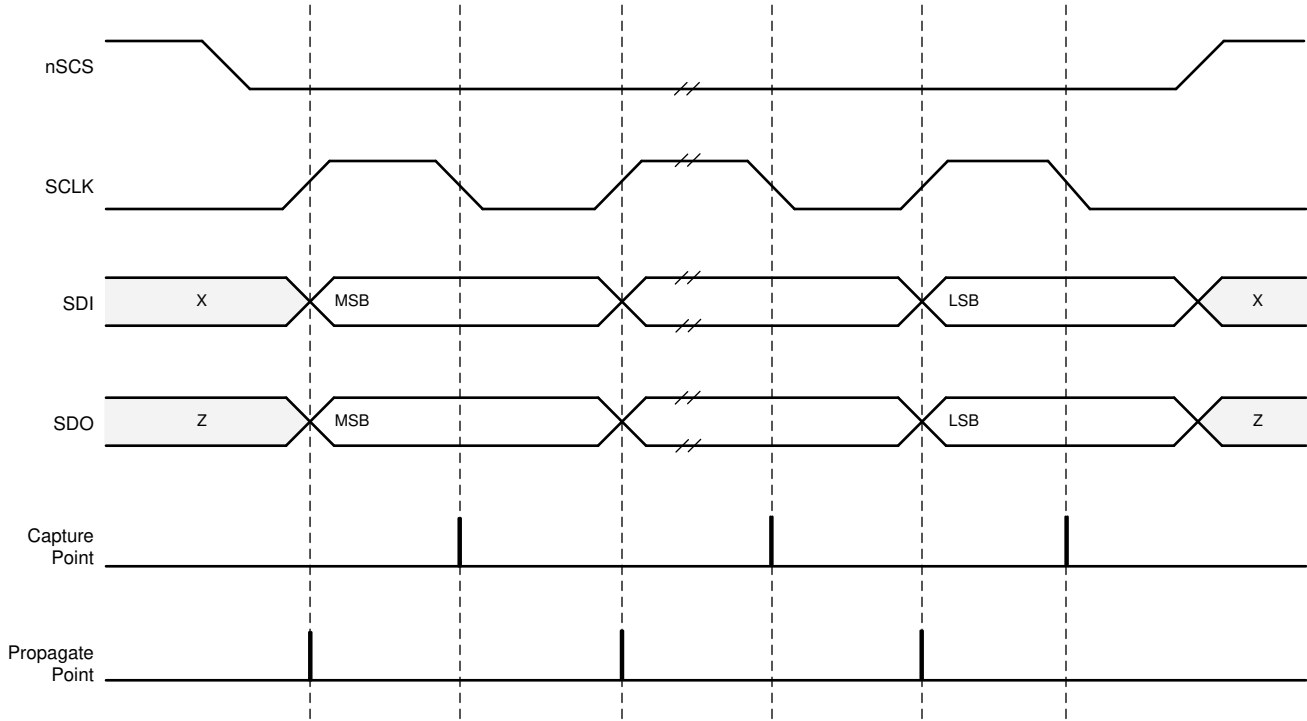
**Figure 6-31. Contents of Header, Status, Address, and Data Bytes**

When data passes through a device, it determines the position of itself in the chain by counting the number of status bytes it receives followed by the first header byte. For example, in this 3-device configuration, device 2 in the chain receives two status bytes before receiving the HDR1 byte which is then followed by the HDR2 byte.

From the two status bytes, the data can determine that its position is second in the chain. From the HDR2 byte, the data can determine how many devices are connected in the chain. In this way, the data only loads

the relevant address and data byte in its buffer and bypasses the other bits. This protocol allows for faster communication without adding latency to the system for up to 63 devices in the chain.

The address and data bytes remain the same with respect to a 1-device connection. The report bytes (R1 through R3), as shown in [Figure 6-29](#), are the content of the register being accessed.



**Figure 6-32. SPI Transaction**

## 7 Register Maps

Table 7-1 lists the memory-mapped registers for the DRV8889-Q1 device. All register addresses not listed in Table 7-1 should be considered as reserved locations and the register contents should not be modified.

Table 7-2 lists the memory-mapped registers for the DRV8889A-Q1 device. All register addresses not listed in Table 7-2 should be considered as reserved locations and the register contents should not be modified.

**Table 7-1. Memory Map**

Register Name	7	6	5	4	3	2	1	0	Access Type	Address
FAULT Status	FAULT	SPI_ERROR	UVLO	CPUV	OCF	STL	TF	OL	R	0x00
DIAG Status 1	OCF_LS2_B	OCF_HS2_B	OCF_LS1_B	OCF_HS1_B	OCF_LS2_A	OCF_HS2_A	OCF_LS1_A	OCF_HS1_A	R	0x01
DIAG Status 2	UTW	OTW	OTS	STL_LRN_OK	STALL	RSVD	OL_B	OL_A	R	0x02
CTRL1	TRQ_DAC [3:0]			RSVD		SLEW_RATE [1:0]			RW	0x03
CTRL2	DIS_OUT	RSVD		TOFF [1:0]		DECAY [2:0]			RW	0x04
CTRL3	DIR	STEP	SPI_DIR	SPI_STEP	MICROSTEP_MODE [3:0]				RW	0x05
CTRL4	CLR_FLT	LOCK [2:0]			EN_OL	OCF_MODE	OTSD_MODE	TW_REP	RW	0x06
CTRL5	RSVD		STL_LRN	EN_STL	STL_REP	RSVD			RW	0x07
CTRL6	STALL_TH [7:0]								RW	0x08
CTRL7	TRQ_COUNT [7:0]								R	0x09
CTRL8	RSVD				REV_ID [3:0]				R	0x0A

**Table 7-2. Memory Map**

Register Name	7	6	5	4	3	2	1	0	Access Type	Address
FAULT Status	FAULT	SPI_ERROR	UVLO	CPUV	OCF	STL	TF	OL	R	0x00
DIAG Status 1	OCF_LS2_B	OCF_HS2_B	OCF_LS1_B	OCF_HS1_B	OCF_LS2_A	OCF_HS2_A	OCF_LS1_A	OCF_HS1_A	R	0x01
DIAG Status 2	UTW	OTW	OTS	STL_LRN_OK	STALL	RSVD	OL_B	OL_A	R	0x02
CTRL1	TRQ_DAC [3:0]			RSVD		SLEW_RATE [1:0]			RW	0x03
CTRL2	DIS_OUT	RSVD		TOFF [1:0]		DECAY [2:0]			RW	0x04
CTRL3	DIR	STEP	SPI_DIR	SPI_STEP	MICROSTEP_MODE [3:0]				RW	0x05
CTRL4	CLR_FLT	LOCK [2:0]			EN_OL	OCF_MODE	OTSD_MODE	TW_REP	RW	0x06
CTRL5	RSVD		STL_LRN	EN_STL	STL_REP	OL_TIME [1:0]		EN_SR_BLANK	RW	0x07
CTRL6	STALL_TH [7:0]								RW	0x08
CTRL7	TRQ_COUNT [7:0]								R	0x09
CTRL8	RSVD				REV_ID [3:0]				R	0x0A

The differences between the register maps of the DRV8889-Q1 and DRV8889A-Q1 are - DRV8889A-Q1 has OL\_TIME [1:0] and EN\_SR\_BLANK bits in CTRL5 register to program open-load detection time and slow-decay to drive mode blanking time. Also, the default value of the DIS\_OUT bit in CTRL2 register is different in DRV8889A-Q1.

Complex bit access types are encoded to fit into small table cells. Table 7-3 shows the codes that are used for access types in this section.

**Table 7-3. Access Type Codes**

Access Type	Code	Description
Read Type		
R	R	Read
Write Type		
W	W	Write
Reset or Default Value		
-n		Value after reset or the default value

## 7.1 Status Registers

The status registers are used to reporting warning and fault conditions. Status registers are read-only registers

Table 7-4 lists the memory-mapped registers for the status registers. All register offset addresses not listed in Table 7-4 should be considered as reserved locations and the register contents should not be modified.

**Table 7-4. Status Registers Summary Table**

Address	Register Name	Section
0x00	FAULT status	<a href="#">Go</a>
0x01	DIAG status 1	<a href="#">Go</a>
0x02	DIAG status 2	<a href="#">Go</a>

## 7.2 FAULT Status Register Name (address = 0x00)

FAULT status is shown in Figure 7-1 and described in Figure 7-1.

Read-only

**Figure 7-1. FAULT Status Register**

7	6	5	4	3	2	1	0
FAULT	SPI_ERROR	UVLO	CPUV	OCP	STL	TF	OL
R-0b	R-0b	R-0b	R-0b	R-0b	R-0b	R-0b	R-0b

**Table 7-5. FAULT Status Register Field Descriptions**

Bit	Field	Type	Default	Description
7	FAULT	R	0b	When nFAULT pin is at 1, FAULT bit is 0. When nFAULT pin is at 0, FAULT bit is 1.
6	SPI_ERROR	R	0b	Indicates SPI protocol errors, such as more SCLK pulses than are required or SCLK is absent even though nSCS is low. Becomes high in fault and the nFAULT pin is driven low. Normal operation resumes when the protocol error is removed and a clear faults command has been issued either through the CLR_FLT bit or an nSLEEP reset pulse.
5	UVLO	R	0b	Indicates an undervoltage lockout fault condition.
4	CPUV	R	0b	Indicates charge pump undervoltage fault condition.
3	OCP	R	0b	Indicates overcurrent fault condition
2	STL	R	0b	Indicates motor stall condition.
1	TF	R	0b	Logic OR of the overtemperature warning, undertemperature warning and overtemperature shutdown.
0	OL	R	0b	Indicates open-load condition.

## 7.3 DIAG Status 1 (address = 0x01)

DIAG Status 1 is shown in Figure 7-2 and described in Table 7-6.

Read-only

**Figure 7-2. DIAG Status 1 Register**

7	6	5	4	3	2	1	0
OCP_LS2_B	OCP_HS2_B	OCP_LS1_B	OCP_HS1_B	OCP_LS2_A	OCP_HS2_A	OCP_LS1_A	OCP_HS1_A
R-0b	R-0b	R-0b	R-0b	R-0b	R-0b	R-0b	R-0b

**Table 7-6. DIAG Status 1 Register Field Descriptions**

Bit	Field	Type	Default	Description
7	OCP_LS2_B	R	0b	Indicates overcurrent fault on the low-side FET of half bridge 2 in BOUT
6	OCP_HS2_B	R	0b	Indicates overcurrent fault on the high-side FET of half bridge 2 in BOUT
5	OCP_LS1_B	R	0b	Indicates overcurrent fault on the low-side FET of half bridge 1 in BOUT
4	OCP_HS1_B	R	0b	Indicates overcurrent fault on the high-side FET of half bridge 1 in BOUT
3	OCP_LS2_A	R	0b	Indicates overcurrent fault on the low-side FET of half bridge 2 in AOUT
2	OCP_HS2_A	R	0b	Indicates overcurrent fault on the high-side FET of half bridge 2 in AOUT
1	OCP_LS1_A	R	0b	Indicates overcurrent fault on the low-side FET of half bridge 1 in AOUT
0	OCP_HS1_A	R	0b	Indicates overcurrent fault on the high-side FET of half bridge 1 in AOUT

#### 7.4 DIAG Status 2 (address = 0x02)

DIAG Status 2 is shown in [Figure 7-3](#) and described in [Table 7-7](#).

Read-only

**Figure 7-3. DIAG Status 2 Register**

7	6	5	4	3	2	1	0
UTW	OTW	OTS	STL_LRN_OK	STALL	RSVD	OL_B	OL_A
R-0b	R-0b	R-0b	R-0b	R-0b	R-0b	R-0b	R-0b

**Table 7-7. DIAG Status 2 Register Field Descriptions**

Bit	Field	Type	Default	Description
7	UTW	R	0b	Indicates undertemperature warning.
6	OTW	R	0b	Indicates overtemperature warning.
5	OTS	R	0b	Indicates overtemperature shutdown.
4	STL_LRN_OK	R	0b	Indicates stall detection learning is successful
3	STALL	R	0b	Indicates motor stall condition
2	RSVD	R	0b	Reserved.
1	OL_B	R	0b	Indicates open-load detection on BOUT
0	OL_A	R	0b	Indicates open-load detection on AOUT

#### 7.5 Control Registers

The IC control registers are used to configure the device. Status registers are read and write capable.

[Table 7-8](#) lists the memory-mapped registers for the control registers. All register offset addresses not listed in [Table 7-8](#) should be considered as reserved locations and the register contents should not be modified.

**Table 7-8. Control Registers Summary Table**

Address	Register Name	Section
0x03	CTRL1	<a href="#">Go</a>
0x04	CTRL2	<a href="#">Go</a>
0x05	CTRL3	<a href="#">Go</a>
0x06	CTRL4	<a href="#">Go</a>
0x07	CTRL5	<a href="#">Go</a>
0x08	CTRL6	<a href="#">Go</a>
0x09	CTRL7	<a href="#">Go</a>

**7.6 CTRL1 Control Register (address = 0x03)**

CTRL1 control is shown in [Figure 7-4](#) and described in [Table 7-9](#).

Read/Write

**Figure 7-4. CTRL1 Control Register**

7	6	5	4	3	2	1	0
TRQ_DAC [3:0]				RSVD		SLEW_RATE [1:0]	
R/W-0000b				R/W-00b		R/W-00b	

**Table 7-9. CTRL1 Control Register Field Descriptions**

Bit	Field	Type	Default	Description
7-4	TRQ_DAC [3:0]	R/W	0000b	<b>0000b = 100%</b> 0001b = 93.75% 0010b = 87.5% 0011b = 81.25% 0100b = 75% 0101b = 68.75% 0110b = 62.5% 0111b = 56.25% 1000b = 50% 1001b = 43.75% 1010b = 37.5% 1011b = 31.25% 1100b = 25% 1101b = 18.75% 1110b = 12.5% 1111b = 6.25%
3-2	RSVD	R/W	00b	Reserved
1-0	SLEW_RATE [1:0]	R/W	00b	<b>00b = 10-V/μs</b> 01b = 35-V/μs 10b = 50-V/μs 11b = 105-V/μs

**7.7 CTRL2 Control Register (address = 0x04)**

CTRL2 is shown in [Figure 7-5](#) and CTRL2 Control Register for DRV8889A-Q1 and described in [Table 7-10](#).

Read/Write

**Figure 7-5. CTRL2 Control Register for DRV8889-Q1**

7	6	5	4	3	2	1	0
---	---	---	---	---	---	---	---

**Figure 7-5. CTRL2 Control Register for DRV8889-Q1 (continued)**

DIS_OUT	RSVD	TOFF [1:0]	DECAY [2:0]
R/W-0b	R/W-00b	R/W-01b	R/W-111b

**Table 7-10. CTRL2 Control Register Field Descriptions for DRV8889-Q1**

Bit	Field	Type	Default	Description
7	DIS_OUT	R/W	0b (DRV8889-Q1) 1b (DRV8889A-Q1)	Write '1' to Hi-Z all outputs. Write '0' to enable all outputs. OR'ed with DRVOFF pin. To prevent false OL detection, ensure OL fault detection is disabled by writing '0' to EN_OL bit, before making the outputs Hi-Z by writing '1' to DIS_OUT.
6-5	RSVD	R/W	00b	Reserved
4-3	TOFF [1:0]	R/W	01b	00b = 7 $\mu$ s <b>01b = 16 <math>\mu</math>s</b> 10b = 24 $\mu$ s 11b = 32 $\mu$ s
2-0	DECAY [2:0]	R/W	111b	000b = Increasing SLOW, decreasing SLOW 001b = Increasing SLOW, decreasing MIXED 30% 010b = Increasing SLOW, decreasing MIXED 60% 011b = Increasing SLOW, decreasing FAST 100b = Increasing MIXED 30%, decreasing MIXED 30% 101b = Increasing MIXED 60%, decreasing MIXED 60% 110b = Smart tune Dynamic Decay <b>111b = Smart tune Ripple Control</b>

### 7.8 CTRL3 Control Register (address = 0x05)

CTRL3 is shown in [Figure 7-6](#) and described in [Table 7-11](#).

Read/Write

**Figure 7-6. CTRL3 Control Register**

7	6	5	4	3	2	1	0
DIR	STEP	SPI_DIR	SPI_STEP	MICROSTEP_MODE [3:0]			
R/W-0b	R/W-0b	R/W-0b	R/W-0b	R/W-0000b			

**Table 7-11. CTRL3 Control Register Field Descriptions**

Bit	Field	Type	Default	Description
7	DIR	R/W	0b	Direction input. Logic '1' sets the direction of stepping, when SPI_DIR = 1.
6	STEP	R/W	0b	Step input. Logic '1' causes the indexer to advance one step, when SPI_STEP = 1. This bit is self-clearing, automatically becomes '0' after writing '1'.
5	SPI_DIR	R/W	0b	<b>0b = Outputs follow input pin for DIR</b> 1b = Outputs follow SPI registers DIR
4	SPI_STEP	R/W	0b	<b>0b = Outputs follow input pin for STEP</b> 1b = Outputs follow SPI registers STEP

**Table 7-11. CTRL3 Control Register Field Descriptions (continued)**

Bit	Field	Type	Default	Description
3-0	MICROSTEP_MODE [3:0]	R/W	0000b	<b>0000b = Full step (2-phase excitation) with 100% current</b> 0001b = Full step (2-phase excitation) with 71% current 0010b = Non-circular 1/2 step 0011b = 1/2 step 0100b = 1/4 step 0101b = 1/8 step 0110b = 1/16 step 0111b = 1/32 step 1000b = 1/64 step 1001b = 1/128 step 1010b = 1/256 step 1011b to 1111b = Reserved

**7.9 CTRL4 Control Register (address = 0x06)**

CTRL4 is shown in [Figure 7-7](#) and described in [Table 7-12](#).

Read/Write

**Figure 7-7. CTRL4 Control Register**

7	6	5	4	3	2	1	0
CLR_FLT	LOCK [2:0]			EN_OL	OCP_MODE	OTSD_MODE	TW_REP
R/W-0b	R/W-011b			R/W-0b	R/W-0b	R/W-0b	R/W-0b

**Table 7-12. CTRL4 Control Register Field Descriptions**

Bit	Field	Type	Default	Description
7	CLR_FLT	R/W	0b	Write '1' to this bit to clear all latched fault bits. This bit automatically resets after being written.
6-4	LOCK [2:0]	R/W	011b	Write 110b to lock the settings by ignoring further register writes except to these bits and address 0x06h bit 7 (CLR_FLT). Writing any sequence other than 110b has no effect when unlocked. Write 011b to this register to unlock all registers. Writing any sequence other than 011b has no effect when locked.
3	EN_OL	R/W	0b	Write '1' to enable open load detection
2	OCP_MODE	R/W	0b	<b>0b = Overcurrent condition causes a latched fault</b> 1b = Overcurrent condition causes an automatic retrying fault
1	OTSD_MODE	R/W	0b	<b>0b = Overtemperature condition will cause latched fault</b> 1b = Overtemperature condition will cause automatic recovery fault
0	TW_REP	R/W	0b	<b>0b = Overtemperature or undertemperature warning is not reported on the nFAULT line</b> 1b = Overtemperature or undertemperature warning is reported on the nFAULT line

**7.10 CTRL5 Control Register (address = 0x07)**

CTRL5 for DRV8889A-Q1 is shown in [Figure 7-8](#) and described in [Table 7-13](#).

CTRL5 for DRV8889-Q1 is shown in [Figure 7-9](#) and described in [Table 7-14](#).

DRV8889A-Q1 features programmable open-load detection time using the OL\_TIME [1:0] bits and programmable slow-decay to drive blanking time using the EN\_SR\_BLANK bit.

Read/Write

**Figure 7-8. CTRL5 Control Register for DRV8889A-Q1**

7	6	5	4	3	2	1	0
RSVD		STL_LRN	EN_STL	STL_REP	OL_TIME [1:0]		EN_SR_BLANK
R/W-00b		R/W-0b	R/W-0b	R/W-1b	R/W-00b		R/W-0b

**Figure 7-9. CTRL5 Control Register for DRV8889-Q1**

7	6	5	4	3	2	1	0
RSVD		STL_LRN	EN_STL	STL_REP	RSVD		
R/W-00b		R/W-0b	R/W-0b	R/W-1b	R/W-000b		

**Table 7-13. CTRL5 Control Register Field Descriptions for DRV8889A-Q1**

Bit	Field	Type	Default	Description
7-6	RSVD	R/W	00b	Reserved. Should always be '00'.
5	STL_LRN	R/W	0b	Write '1' to learn stall count for stall detection. This bit automatically returns to '0' when the stall learning process is complete.
4	EN_STL	R/W	0b	<b>0b = Stall detection is disabled</b> 1b = Stall detection is enabled
3	STL_REP	R/W	1b	0b = Stall detection is not reported on nFAULT <b>1b = Stall detection is reported on nFAULT</b>
2-1	OL_TIME [1:0]	R/W	00b	<b>00b = 200ms (max.) open load detection time</b> 01b = 125ms (max.) open load detection time 10b = 75ms (max.) open load detection time 11b = 3ms (max.) open load detection time
0	EN_SR_BLANK	R/W	0b	<b>0b = 500ns slow-decay to drive blanking time</b> 1b = slow-decay to drive blanking will depend on slew rate, shown in <a href="#">Table 6-9</a> .

**Table 7-14. CTRL5 Control Register Field Descriptions for DRV8889-Q1**

Bit	Field	Type	Default	Description
7-6	RSVD	R/W	00b	Reserved. Should always be '00'.
5	STL_LRN	R/W	0b	Write '1' to learn stall count for stall detection. This bit automatically returns to '0' when the stall learning process is complete.
4	EN_STL	R/W	0b	<b>0b = Stall detection is disabled</b> 1b = Stall detection is enabled
3	STL_REP	R/W	1b	0b = Stall detection is not reported on nFAULT <b>1b = Stall detection is reported on nFAULT</b>
2-0	RSVD	R/W	000b	Reserved. Should always be '000'.

### 7.11 CTRL6 Control Register (address = 0x08)

CTRL6 is shown in [Figure 7-10](#) and described in [Table 7-15](#).

Read/Write

**Figure 7-10. CTRL6 Control Register**

7	6	5	4	3	2	1	0
STALL_TH [7:0] R/W-00001111b							

**Table 7-15. CTRL6 Control Register Field Descriptions**

Bit	Field	Type	Default	Description
7-0	STALL_TH [7:0]	R/W	00001111b	00000000b = 0 count XXXXXXXXb = 1 to 254 counts 11111111b = 255 counts

**7.12 CTRL7 Control Register (address = 0x09)**

CTRL7 is shown in [Figure 7-11](#) and described in [Table 7-16](#).

Read-only

**Figure 7-11. CTRL7 Control Register**

7	6	5	4	3	2	1	0
TRQ_COUNT [7:0] R-11111111b							

**Table 7-16. CTRL7 Control Register Field Descriptions**

Bit	Field	Type	Default	Description
7-0	TRQ_COUNT [7:0]	R	11111111b	00000000b = 0 count XXXXXXXXb = 1 to 254 counts 11111111b = 255 counts

**7.13 CTRL8 Control Register (address = 0x0A)**

CTRL8 is shown in [Figure 7-12](#) and described in [Table 7-17](#).

Read-only

**Figure 7-12. CTRL8 Control Register**

7	6	5	4	3	2	1	0
RSVD				REV_ID [3:0]			
R-0000b				R-0010b			

**Table 7-17. CTRL8 Control Register Field Descriptions**

Bit	Field	Type	Default	Description
7-4	RSVD	R	0000b	Reserved
3-0	REV_ID	R	0010b	Silicon Revision Identification. 0000b indicates 1 <sup>st</sup> Prototype Revision. 0001b indicates 2 <sup>nd</sup> Prototype Revision. 0010b indicates Production Revision. 0011b indicates DRV8889A variant.

## 8 Application and Implementation

### Note

Information in the following applications sections is not part of the TI component specification, and TI does not warrant its accuracy or completeness. TI's customers are responsible for determining suitability of components for their purposes. Customers should validate and test their design implementation to confirm system functionality.

### 8.1 Application Information

The DRV8889-Q1 and DRV8889A-Q1 devices are used in bipolar stepper control.

### 8.2 Typical Application

The following design procedure can be used to configure the DRV8889-Q1 and DRV8889A-Q1 devices.

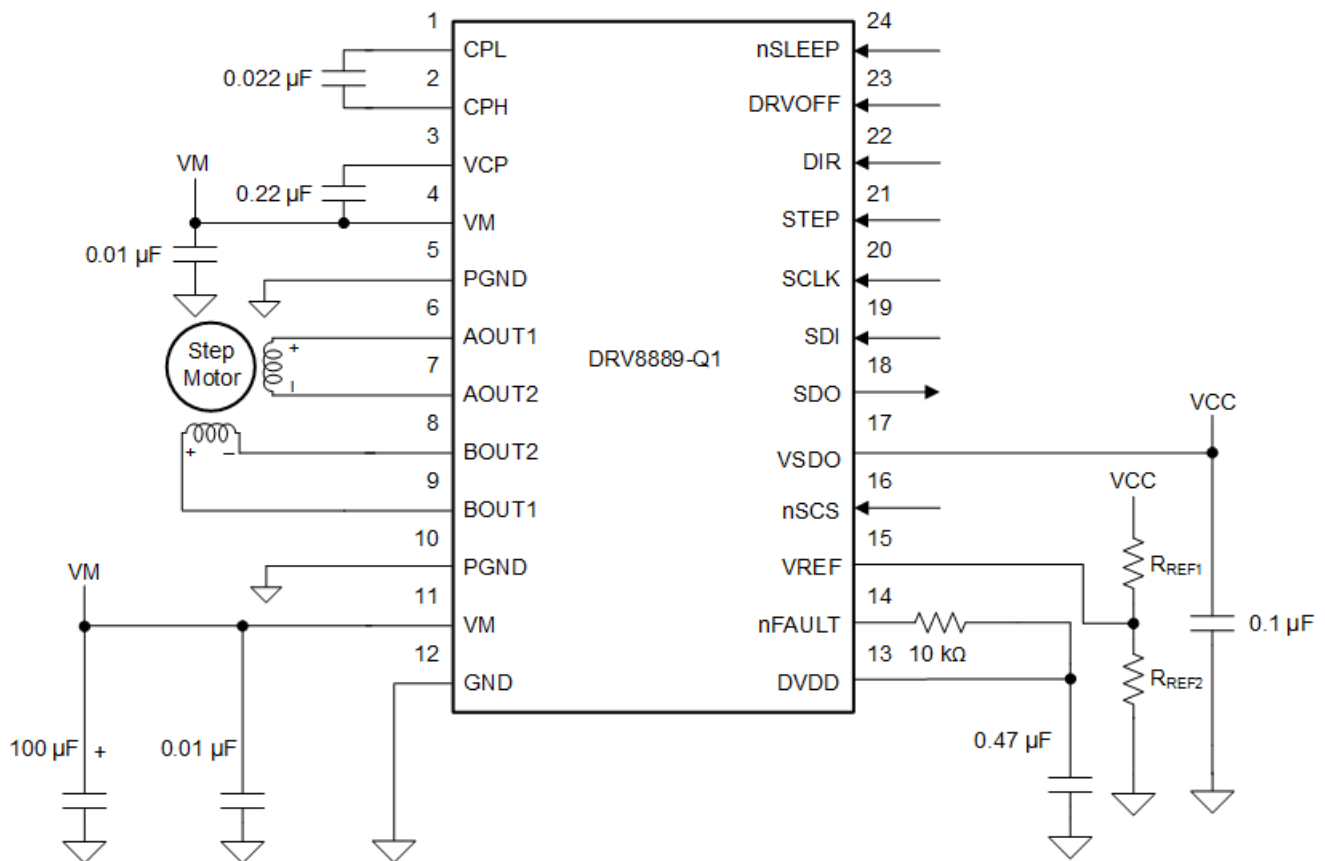


Figure 8-1. Typical Application Schematic (HTSSOP package)

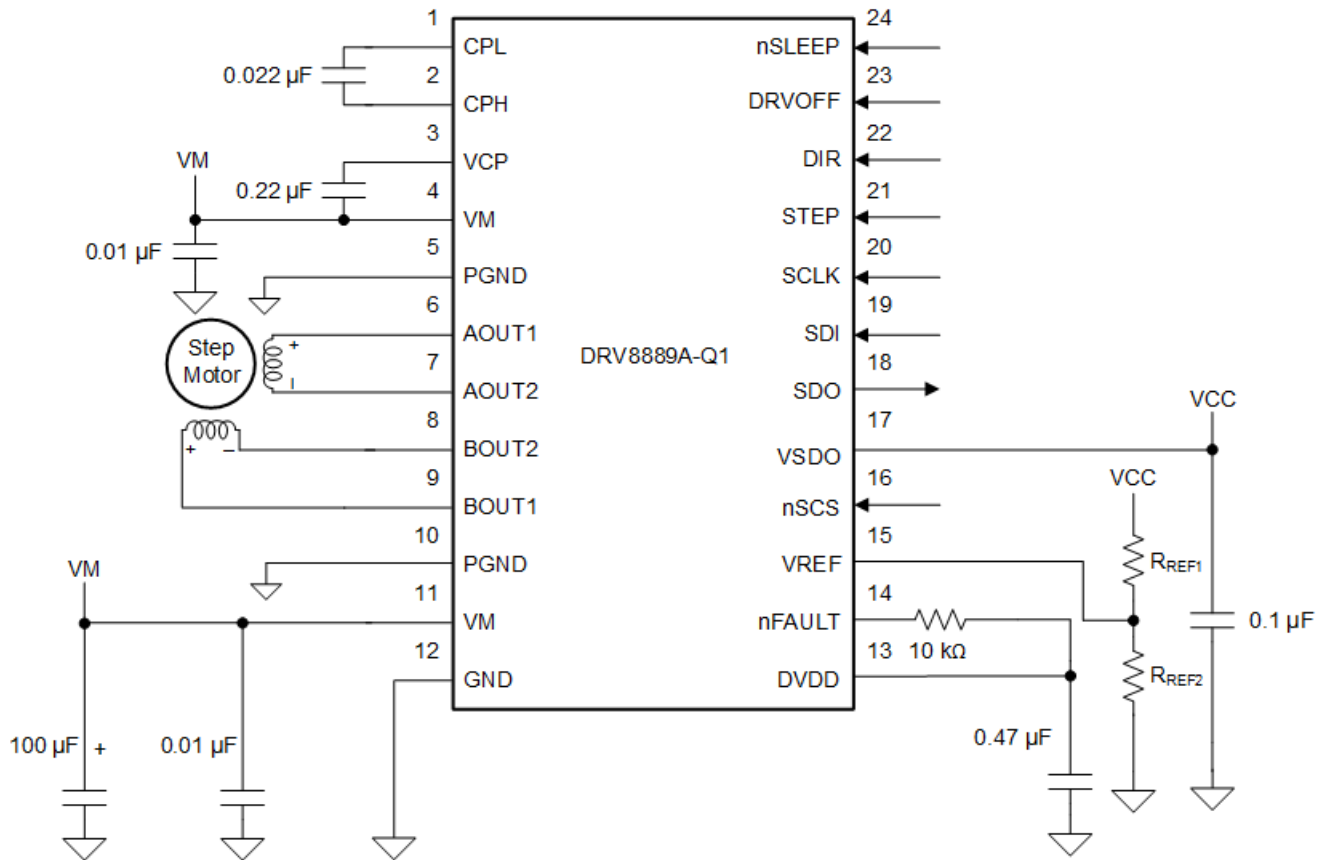
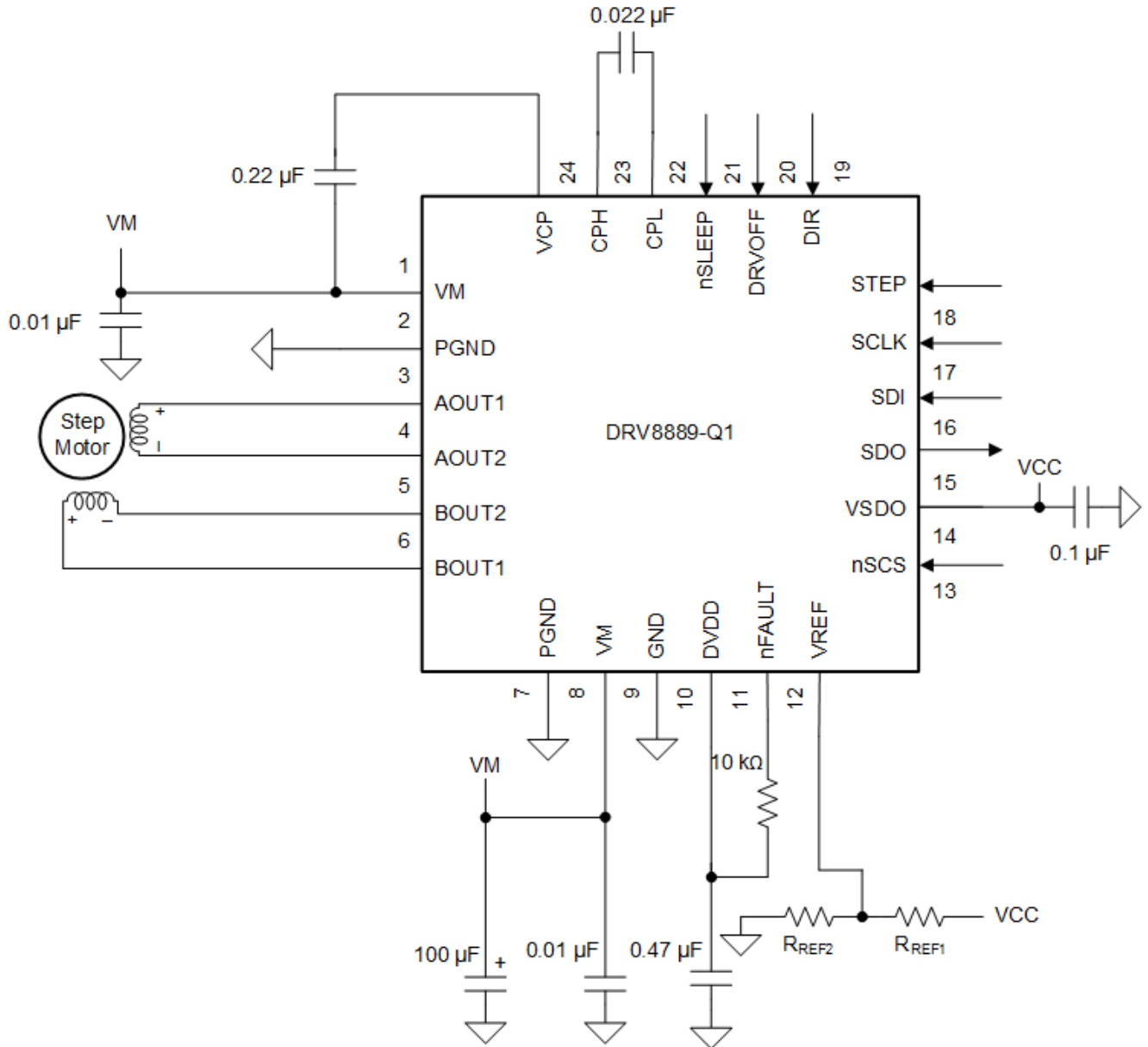


Figure 8-2. Typical Application Schematic (HTSSOP package)



**Figure 8-3. Typical Application Schematic (VQFN package)**

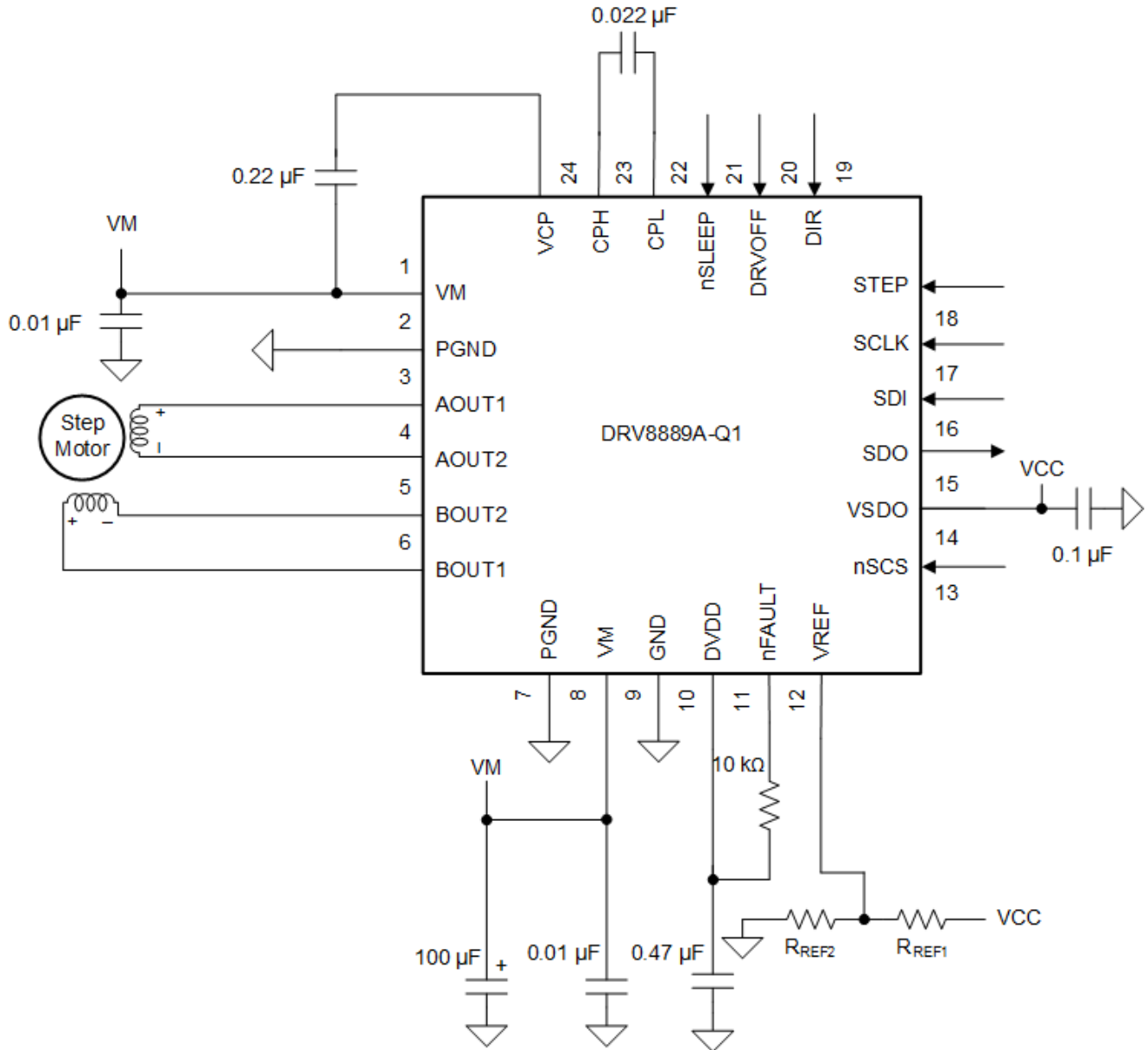


Figure 8-4. Typical Application Schematic (VQFN package)

### 8.2.1 Design Requirements

Table 8-1 lists the design input parameters for a typical adaptive headlight application.

Table 8-1. Design Parameters

DESIGN PARAMETER	REFERENCE	EXAMPLE VALUE
Supply voltage	VM	9 V to 16 V, 13.5 V Nominal
Motor winding resistance	$R_L$	7.7 $\Omega$ /phase
Motor full step angle	$\theta_{step}$	15°/step
Target microstepping level	$n_m$	1/8 step
Target motor speed	$v$	300 rpm
Target full-scale current	$I_{FS}$	500 mA

## 8.2.2 Detailed Design Procedure

### 8.2.2.1 Stepper Motor Speed

The first step in configuring the device requires the desired motor speed and microstepping level. If the target application requires a constant speed, then a square wave with frequency  $f_{\text{step}}$  must be applied to the STEP pin. If the target motor speed is too high, the motor does not spin. Make sure that the motor can support the target speed. Use Equation 2 to calculate  $f_{\text{step}}$  for a desired motor speed ( $v$ ), microstepping level ( $n_m$ ), and motor full step angle ( $\theta_{\text{step}}$ )

$$f_{\text{step}} \text{ (steps / s)} = \frac{v \text{ (rpm)} \times 360 \text{ (}^\circ \text{ / rot)}}{\theta_{\text{step}} \text{ (}^\circ \text{ / step)} \times n_m \text{ (steps / microstep)} \times 60 \text{ (s / min)}} \quad (2)$$

The value of  $\theta_{\text{step}}$  can be found in the stepper motor data sheet, or written on the motor.

For example, the motor in this adaptive headlight application is required to rotate at  $15^\circ/\text{step}$  for a target of 300 rpm at 1/8 microstep mode. Using Equation 2,  $f_{\text{step}}$  can be calculated as 960 Hz.

The microstepping level is set by the MICROSTEP\_MODE bits in the SPI register and can be any of the settings listed in Table 8-2. Higher microstepping results in a smoother motor motion and less audible noise, but increases switching losses and requires a higher  $f_{\text{step}}$  to achieve the same motor speed.

**Table 8-2. Microstepping Indexer Settings**

MICROSTEP_MODE	STEP MODE
0000b	Full step (2-phase excitation) with 100% current
0001b	Full step (2-phase excitation) with 71% current
0010b	Non-circular 1/2 step
0011b	1/2 step
0100b	1/4 step
0101b	1/8 step
0110b	1/16 step
0111b	1/32 step
1000b	1/64 step
1001b	1/128 step
1010b	1/256 step

### 8.2.2.2 Current Regulation

In a stepper motor, the full-scale current ( $I_{\text{FS}}$ ) is the maximum current driven through either winding. This quantity depends on the VREF voltage and the TRQ\_DAC setting.

The maximum allowable voltage on the VREF pin is 3.3 V. DVDD can be used to provide VREF through a resistor divider.

During stepping,  $I_{\text{FS}}$  defines the current chopping threshold ( $I_{\text{TRIP}}$ ) for the maximum current step.

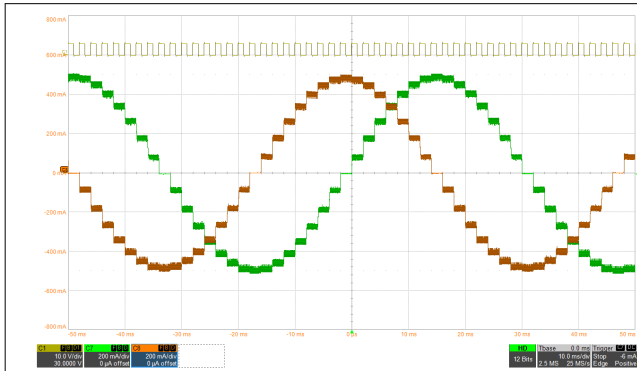
$$I_{\text{FS}} \text{ (A)} = \frac{V_{\text{REF}} \text{ (V)}}{K_v \text{ (V/A)}} \times \text{TRQ\_DAC} \text{ (\%)} = \frac{V_{\text{REF}} \text{ (V)} \times \text{TRQ\_DAC} \text{ (\%)}}{2.2 \text{ (V/A)}} \quad (3)$$

### 8.2.2.3 Decay Modes

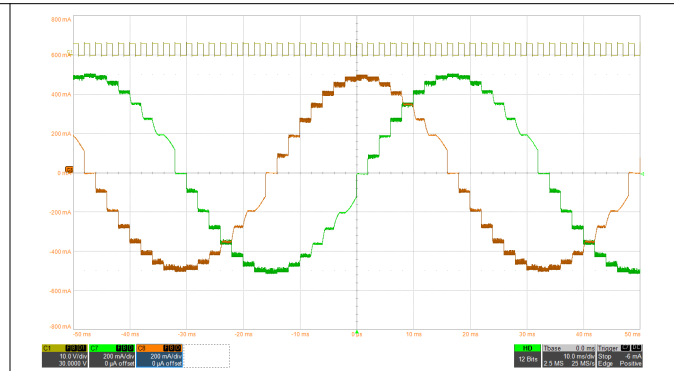
The device supports eight different decay modes, as shown in Table 6-7. The current through the motor windings is regulated using an adjustable fixed-time-off scheme which means that after any drive phase, when a motor

winding current has hit the current chopping threshold ( $I_{TRIP}$ ), the device places the winding in one of the eight decay modes for  $t_{OFF}$ . After  $t_{OFF}$ , a new drive phase starts.

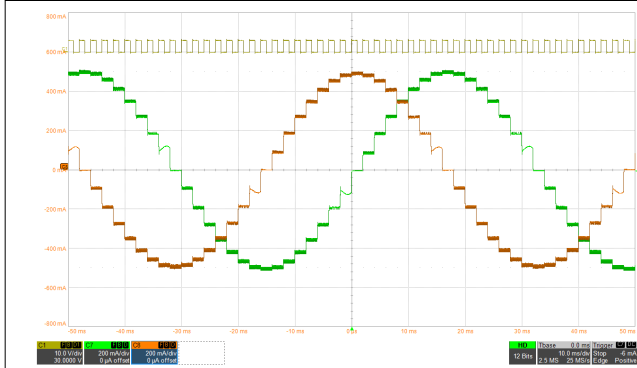
### 8.2.3 Application Curves



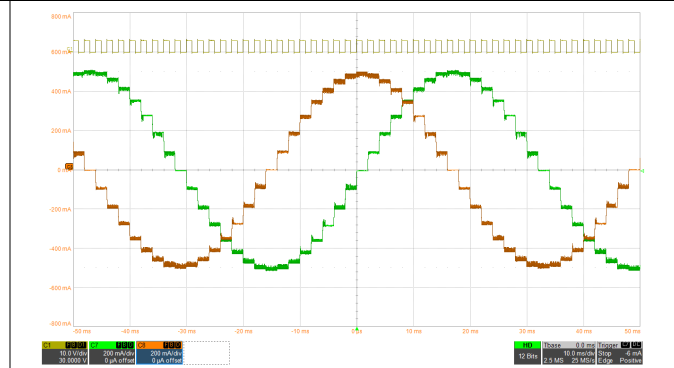
**Figure 8-5. 1/8 Microstepping With Mixed30-Mixed30 Decay**



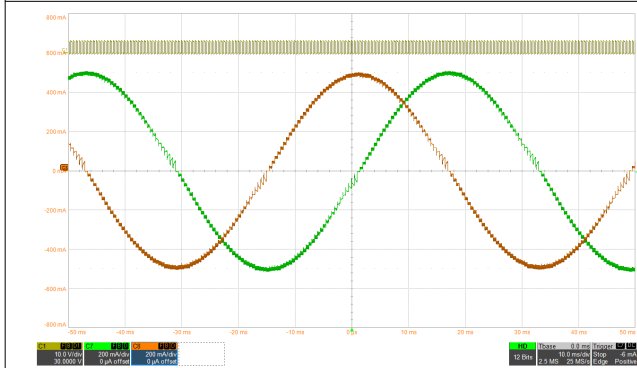
**Figure 8-6. 1/8 Microstepping With Slow-Slow Decay**



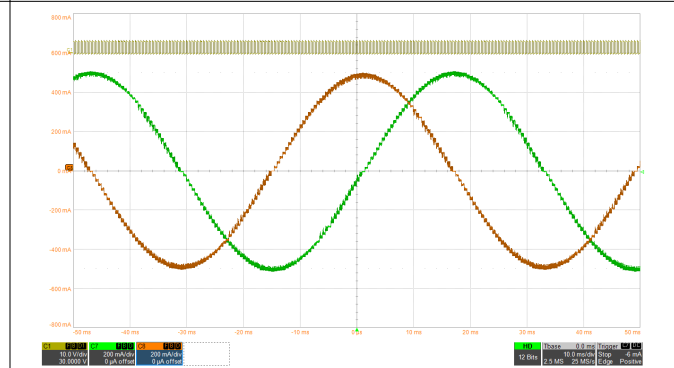
**Figure 8-7. 1/8 Microstepping With smart tune Ripple Control Decay**



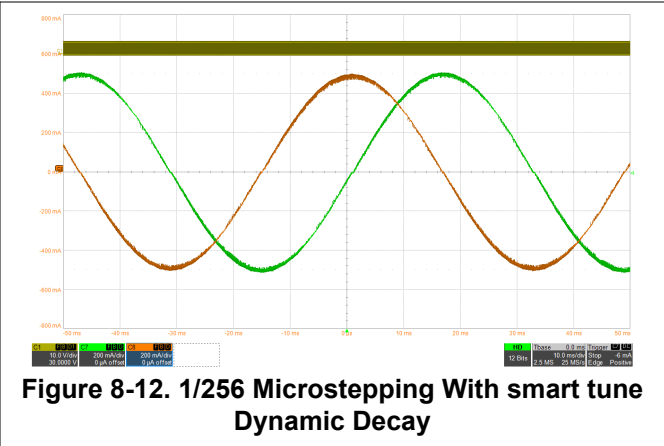
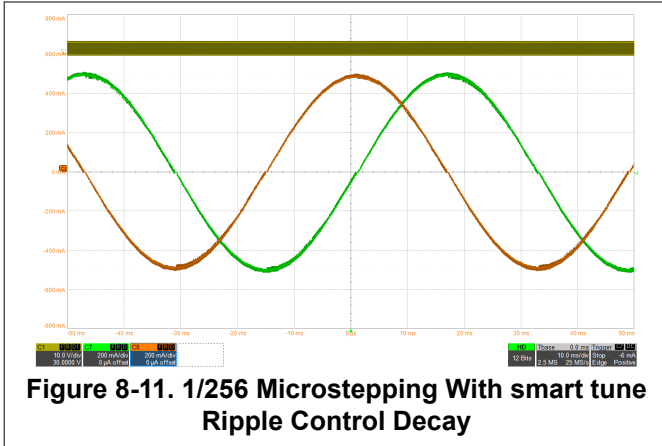
**Figure 8-8. 1/8 Microstepping With smart tune Dynamic Decay**



**Figure 8-9. 1/32 Microstepping With smart tune Ripple Control Decay**



**Figure 8-10. 1/32 Microstepping With smart tune Dynamic Decay**



## 8.2.4 Thermal Application

This section presents the power dissipation calculation and junction temperature estimation of the device.

### 8.2.4.1 Power Dissipation

The total power dissipation constitutes of three main components - conduction loss ( $P_{COND}$ ), switching loss ( $P_{SW}$ ) and power loss due to quiescent current consumption ( $P_Q$ ).

#### 8.2.4.1.1 Conduction Loss

The current path for a motor connected in full-bridge is through the high-side FET of one half-bridge and low-side FET of the other half-bridge. The conduction loss ( $P_{COND}$ ) depends on the motor rms current ( $I_{RMS}$ ) and high-side ( $R_{DS(ONH)}$ ) and low-side ( $R_{DS(ONL)}$ ) on-state resistances as shown in [Equation 4](#).

$$P_{COND} = 2 \times (I_{RMS})^2 \times (R_{DS(ONH)} + R_{DS(ONL)}) \quad (4)$$

The conduction loss for the typical application shown in [Section 8.2.1](#) is calculated in [Equation 5](#).

$$P_{COND} = 2 \times (I_{RMS})^2 \times (R_{DS(ONH)} + R_{DS(ONL)}) = 2 \times (500\text{-mA} / \sqrt{2})^2 \times (0.45\text{-}\Omega + 0.45\text{-}\Omega) = 225\text{-mW} \quad (5)$$

---

#### Note

This power calculation is highly dependent on the device temperature which significantly effects the high-side and low-side on-resistance of the FETs. For more accurate calculation, consider the dependency of on-resistance of FETs with device temperature.

---

#### 8.2.4.1.2 Switching Loss

The power loss due to the PWM switching frequency depends on the slew rate ( $t_{SR}$ ), supply voltage, motor RMS current and the PWM switching frequency. The switching losses in each H-bridge during rise-time and fall-time are calculated as shown in [Equation 6](#) and [Equation 7](#).

$$P_{SW\_RISE} = 0.5 \times V_{VM} \times I_{RMS} \times t_{RISE\_PWM} \times f_{PWM} \quad (6)$$

$$P_{SW\_FALL} = 0.5 \times V_{VM} \times I_{RMS} \times t_{FALL\_PWM} \times f_{PWM} \quad (7)$$

Both  $t_{RISE\_PWM}$  and  $t_{FALL\_PWM}$  can be approximated as  $V_{VM} / t_{SR}$ . After substituting the values of various parameters, and assuming 105 V/ $\mu$ s slew rate and 30-kHz PWM frequency, the switching losses in each H-bridge are calculated as shown below -

$$P_{SW\_RISE} = 0.5 \times 13.5\text{-V} \times (500\text{-mA} / \sqrt{2}) \times (13.5\text{-V} / 105 \text{ V}/\mu\text{s}) \times 30\text{-kHz} = 9.2\text{-mW} \quad (8)$$

$$P_{SW\_FALL} = 0.5 \times 13.5\text{-V} \times (500\text{-mA} / \sqrt{2}) \times (13.5\text{-V} / 105 \text{ V}/\mu\text{s}) \times 30\text{-kHz} = 9.2\text{-mW} \quad (9)$$

The total switching loss ( $P_{SW}$ ) is calculated as twice the sum of rise-time ( $P_{SW\_RISE}$ ) switching loss and fall-time ( $P_{SW\_FALL}$ ) switching loss as shown below -

$$P_{SW} = 2 \times (P_{SW\_RISE} + P_{SW\_FALL}) = 2 \times (9.2\text{-mW} + 9.2\text{-mW}) = 36.8\text{-mW} \quad (10)$$

### Note

The rise-time ( $t_{RISE}$ ) and the fall-time ( $t_{FALL}$ ) are calculated based on typical values of the slew rate ( $t_{SR}$ ). This parameter is expected to change based on the supply-voltage, temperature and device to device variation.

The switching loss is inversely proportional to the output slew rate. 10 V/ $\mu$ s slew rate will result in approximately ten times higher switching loss than 105 V/ $\mu$ s slew rate. However, lower slew rates tend to result in better EMC performance of the driver. A careful trade-off analysis needs to be performed to arrive at an appropriate slew rate for an application.

The switching loss is directly proportional to the PWM switching frequency. The PWM frequency in an application will depend on the supply voltage, inductance of the motor coil, back emf voltage and OFF time or the ripple current (for smart tune ripple control decay mode).

#### 8.2.4.1.3 Power Dissipation Due to Quiescent Current

The power dissipation due to the quiescent current consumed by the power supply is calculated as shown below -

$$P_Q = V_{VM} \times I_{VM} \quad (11)$$

Substituting the values, quiescent power loss can be calculated as shown below -

$$P_Q = 13.5\text{-V} \times 5\text{-mA} = 67.5\text{-mW} \quad (12)$$

### Note

The quiescent power loss is calculated using the typical operating supply current ( $I_{VM}$ ) which is dependent on supply-voltage, temperature and device to device variation.

#### 8.2.4.1.4 Total Power Dissipation

The total power dissipation ( $P_{TOT}$ ) is calculated as the sum of conduction loss, switching loss and the quiescent power loss as shown in [Equation 13](#).

$$P_{TOT} = P_{COND} + P_{SW} + P_Q = 225\text{-mW} + 36.8\text{-mW} + 67.5\text{-mW} = 329.3\text{-mW} \quad (13)$$

#### 8.2.4.2 PCB Types

Thermal analysis in this section is focused for the 2-layer and 4-layer PCB with two different copper thickness (1-oz and 2-oz) and six different copper areas (1-cm<sup>2</sup>, 2-cm<sup>2</sup>, 4-cm<sup>2</sup>, 8-cm<sup>2</sup>, 16-cm<sup>2</sup> and 32-cm<sup>2</sup>), for both HTSSOP and VQFN packages.

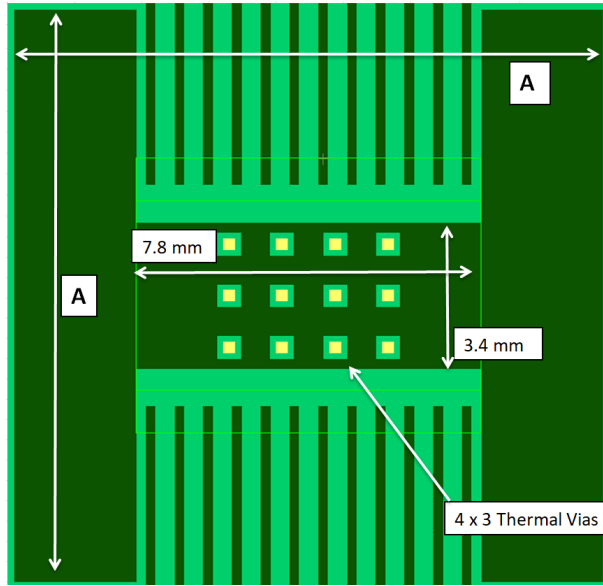
[Figure 8-13](#) and [Figure 8-14](#) show the top-layer which is applicable for both 2/4-layer PCB, for HTSSOP and VQFN packages respectively. The top-layer, mid-layer-1 and bottom-layer of the PCB is filled with ground plane, whereas, the mid-layer-2 is filled with power plane.

For the HTSSOP, 4 x 3 array of thermal vias with 300  $\mu$ m drill diameter and 25  $\mu$ m Cu plating were placed below the device package. For the VQFN, 2 x 2 array of thermal vias with 300  $\mu$ m drill diameter and 25  $\mu$ m Cu plating were placed below the device package. Thermal vias contacted top-layer, bottom-layer, and mid-layer-1 (ground plane) if applicable. The mid-layers and the bottom-layer were modeled with size A \* A for both 2-layer and 4-layer designs. For the VQFN package, there was no copper on top layer outside of device land area.

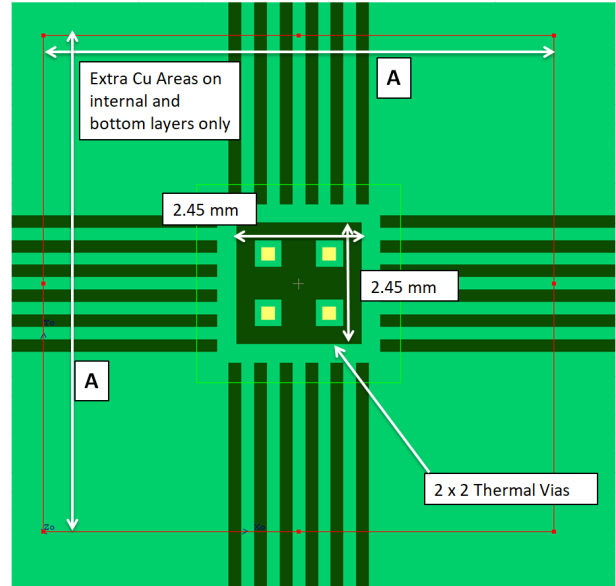
The thickness of copper for different PCB layers in different PCB types is summarized in [Table 8-3](#). The PCB dimension (A) for different PCB copper area is summarized in [Table 8-4](#) for the HTSSOP package, and in [Table 8-5](#) for the VQFN package.

**Table 8-3. PCB Type and Copper Thickness**

PCB Type	Copper Thickness	Top Layer	Bottom Layer	Mid-Layer 1	Mid-Layer 2
2-Layer	1-oz PCB	1-oz	1-oz	N/A	
	2-oz PCB	2-oz	2-oz		
4-Layer	1-oz PCB	1-oz	1-oz	1-oz	1-oz
	2-oz PCB	2-oz	2-oz	1-oz	1-oz



**Figure 8-13. PCB - Top Layer (4/2-Layer PCB) for HTSSOP Package**



**Figure 8-14. PCB - Top Layer (4/2-Layer PCB) for VQFN Package**

**Table 8-4. PCB Dimension for HTSSOP package**

COPPER AREA (cm <sup>2</sup> )	DIMENSION (A) (mm)
1 cm <sup>2</sup>	13.31 mm
2 cm <sup>2</sup>	17.64 mm
4 cm <sup>2</sup>	23.62 mm
8 cm <sup>2</sup>	31.98 mm
16 cm <sup>2</sup>	43.76 mm
32 cm <sup>2</sup>	60.36 mm

**Table 8-5. PCB Dimension for VQFN package**

COPPER AREA (cm <sup>2</sup> )	DIMENSION (A) (mm)
1 cm <sup>2</sup>	10.00 mm
2 cm <sup>2</sup>	14.14 mm
4 cm <sup>2</sup>	20.00 mm
8 cm <sup>2</sup>	28.28 mm
16 cm <sup>2</sup>	40.00 mm
32 cm <sup>2</sup>	56.57 mm

### 8.2.4.3 Thermal Parameters for HTSSOP Package

The variation of thermal parameters such as the  $R_{\theta JA}$  (Junction-to-Ambient Thermal Resistance) and  $\Psi_{JB}$  (Junction-to-Board Characterization Parameter) is highly dependent on the PCB type, package type, copper thickness and the copper pad area.

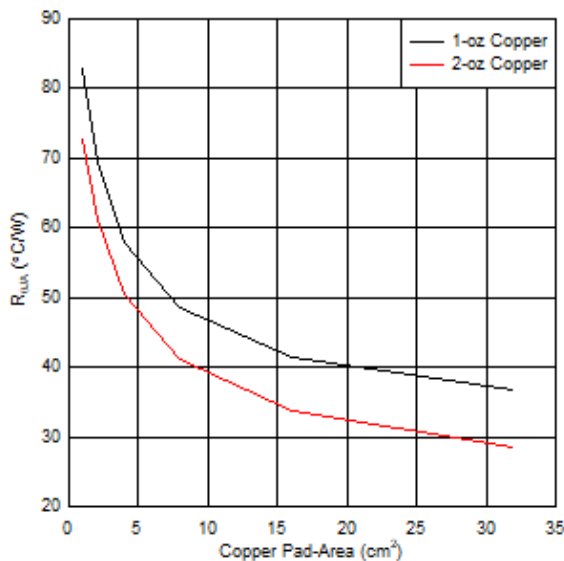
Figure 8-15 and Figure 8-16 show the variation of the  $R_{\theta JA}$  (Junction-to-Ambient Thermal Resistance) and  $\Psi_{JB}$  (Junction-to-Board Characterization Parameter) with copper-pad area for 2-layer PCB, for the HTSSOP package. As shown in these curves, the thermal resistance is lower for the higher copper thickness PCB and the higher copper pad-area.

Similarly, Figure 8-17 and Figure 8-18 show the variation of the  $R_{\theta JA}$  and  $\Psi_{JB}$  with copper-pad area for 4-layer PCB respectively, for the HTSSOP package.

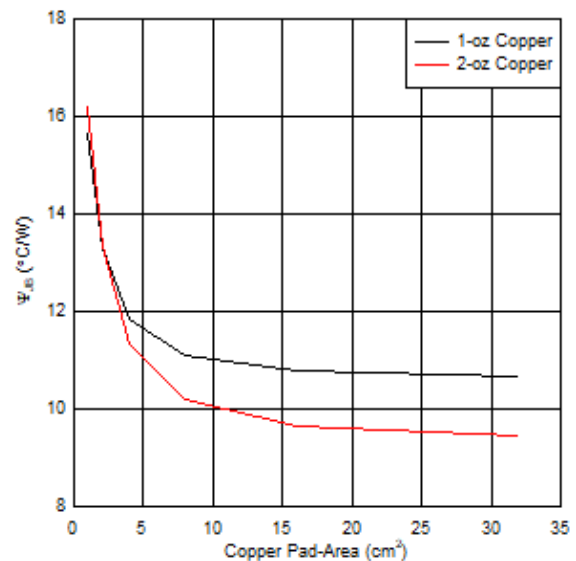
#### Note

The thermal parameters ( $R_{\theta JA}$  (Junction-to-Ambient Thermal Resistance) and  $\Psi_{JB}$  (Junction-to-Board Characterization Parameter)) are calculated considering the ambient temperature of 25°C and with 2-W power evenly dissipated between high-side and low-side FET's. The thermal parameters calculated considering the power dissipation at the actual location of the power-FETs rather than an averaged estimation.

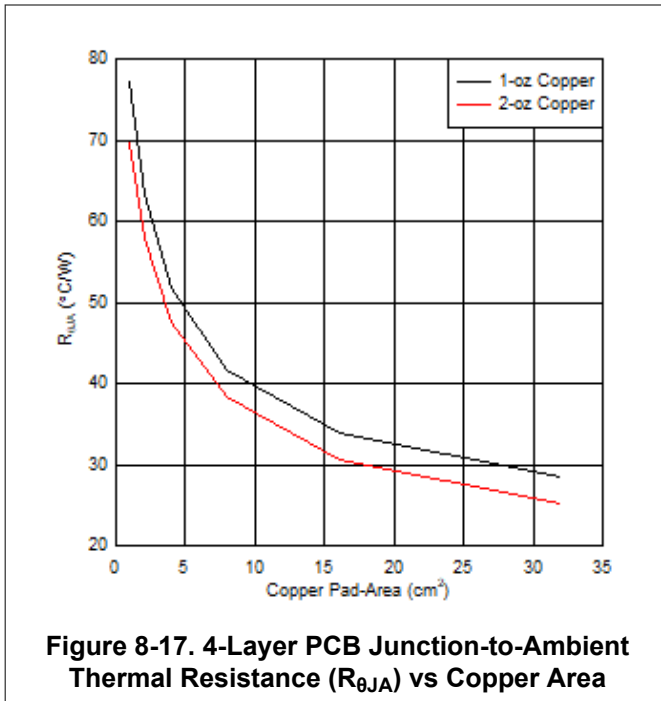
The thermal parameters are highly dependent on the external conditions such as altitude, package geometry etc. Refer to [Application Report](#) for more details.



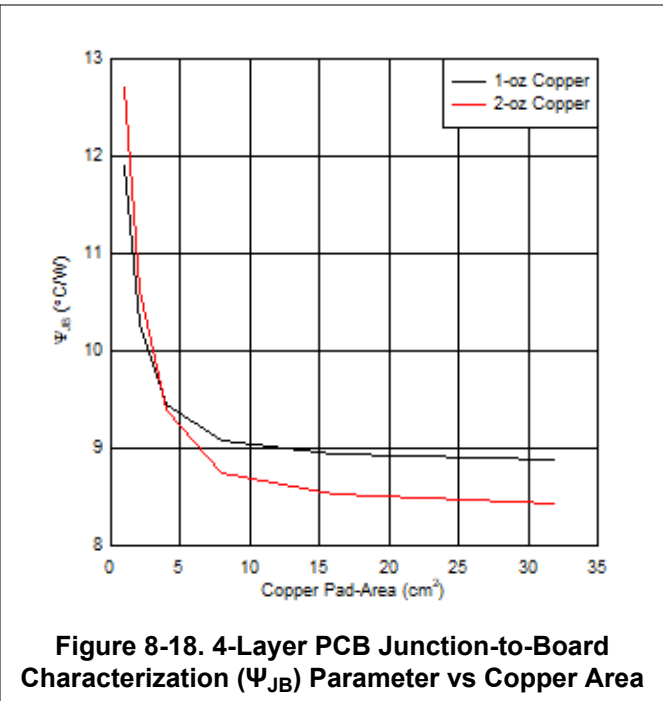
**Figure 8-15. 2-Layer PCB Junction-to-Ambient Thermal Resistance ( $R_{\theta JA}$ ) vs Copper Area**



**Figure 8-16. 2-Layer PCB Junction-to-Board Characterization Parameter ( $\Psi_{JB}$ ) vs Copper Area**



**Figure 8-17. 4-Layer PCB Junction-to-Ambient Thermal Resistance ( $R_{\theta JA}$ ) vs Copper Area**



**Figure 8-18. 4-Layer PCB Junction-to-Board Characterization ( $\Psi_{JB}$ ) Parameter vs Copper Area**

**8.2.4.4 Thermal Parameters for VQFN Package**

Figure 8-19 and Figure 8-20 show the variation of the  $R_{\theta JA}$  (Junction-to-Ambient Thermal Resistance) and  $\Psi_{JB}$  (Junction-to-Board Characterization Parameter) with copper-pad area for 2-layer PCB, for the VQFN package. As shown in these curves, the thermal resistance is lower for the higher copper thickness PCB and the higher copper pad-area.

Similarly, Figure 8-21 and Figure 8-22 show the variation of the  $R_{\theta JA}$  and  $\Psi_{JB}$  with copper-pad area for 4-layer PCB respectively, for the VQFN package.

**Note**

The thermal parameters ( $R_{\theta JA}$  (Junction-to-Ambient Thermal Resistance) and  $\Psi_{JB}$  (Junction-to-Board Characterization Parameter)) are calculated considering the ambient temperature of 25°C and with 2-W power evenly dissipated between high-side and low-side FET's. The thermal parameters calculated considering the power dissipation at the actual location of the power-FETs rather than an averaged estimation.

The thermal parameters are highly dependent on the external conditions such as altitude, package geometry etc. Refer to [Application Report](#) for more details.

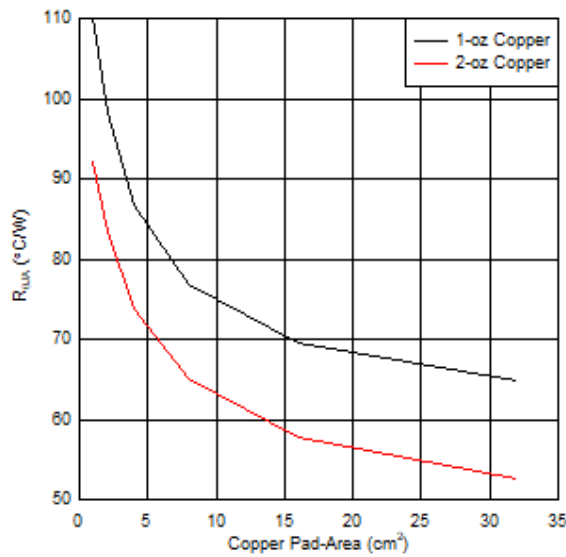


Figure 8-19. 2-Layer PCB Junction-to-Ambient Thermal Resistance ( $R_{\theta JA}$ ) vs Copper Area

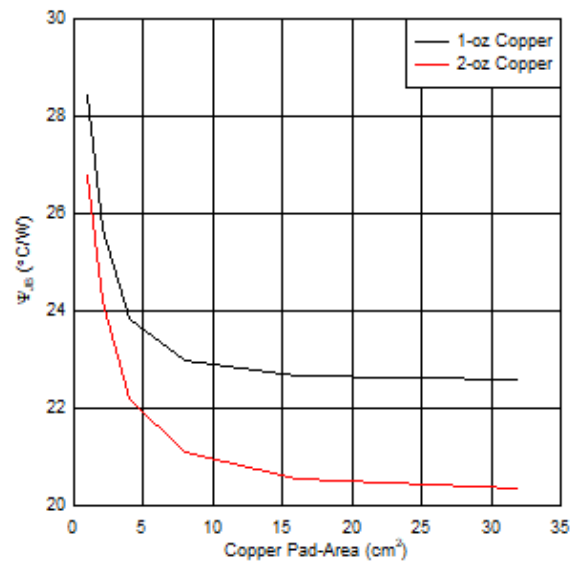


Figure 8-20. 2-Layer PCB Junction-to-Board Characterization Parameter ( $\Psi_{JB}$ ) vs Copper Area

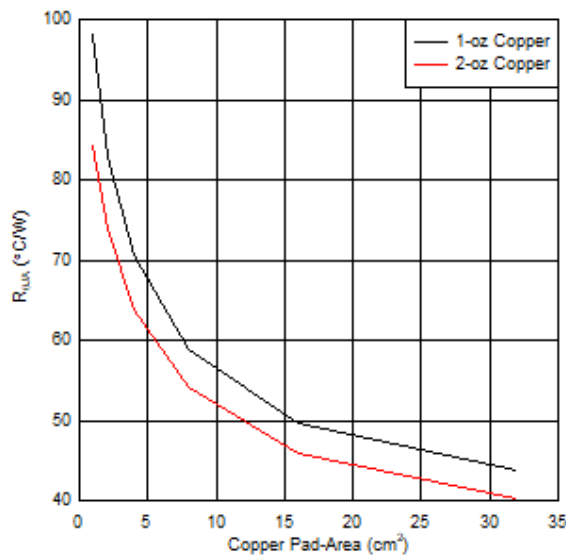


Figure 8-21. 4-Layer PCB Junction-to-Ambient Thermal Resistance ( $R_{\theta JA}$ ) vs Copper Area

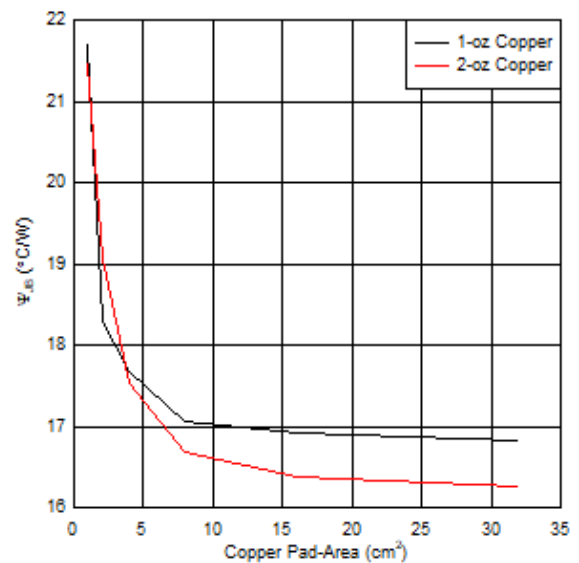


Figure 8-22. 4-Layer PCB Junction-to-Board Characterization ( $\Psi_{JB}$ ) Parameter vs Copper Area

#### 8.2.4.5 Device Junction Temperature Estimation

For an ambient temperature of  $T_A$  and total power dissipation ( $P_{TOT}$ ), the junction temperature ( $T_J$ ) is calculated as shown in the following equation.  $T_J = T_A + (P_{TOT} \times R_{\theta JA})$

Considering a JEDEC standard 4-layer PCB, the junction-to-ambient thermal resistance ( $R_{\theta JA}$ ) is 30.9 °C/W for the HTSSOP package and 40.7 °C/W for the VQFN package.

Assuming 25°C ambient temperature, the junction temperature for the HTSSOP package is calculated as shown below -

$$T_J = 25^{\circ}\text{C} + (0.3293\text{-W} \times 30.9^{\circ}\text{C/W}) = 35.18^{\circ}\text{C} \quad (14)$$

The junction temperature for the VQFN package is calculated as shown below -

$$T_J = 25^{\circ}\text{C} + (0.3293\text{-W} \times 40.7^{\circ}\text{C/W}) = 38.4^{\circ}\text{C} \quad (15)$$

### 8.3 Power Supply Recommendations

The device is designed to operate from an input voltage supply (VM) range from 4.5 V to 45 V. A 0.01- $\mu\text{F}$  ceramic capacitor rated for VM must be placed at each VM pin as close to the device as possible. In addition, a bulk capacitor must be included on VM.

#### 8.3.1 Bulk Capacitance

Having appropriate local bulk capacitance is an important factor in motor drive system design. It is generally beneficial to have more bulk capacitance, while the disadvantages are increased cost and physical size.

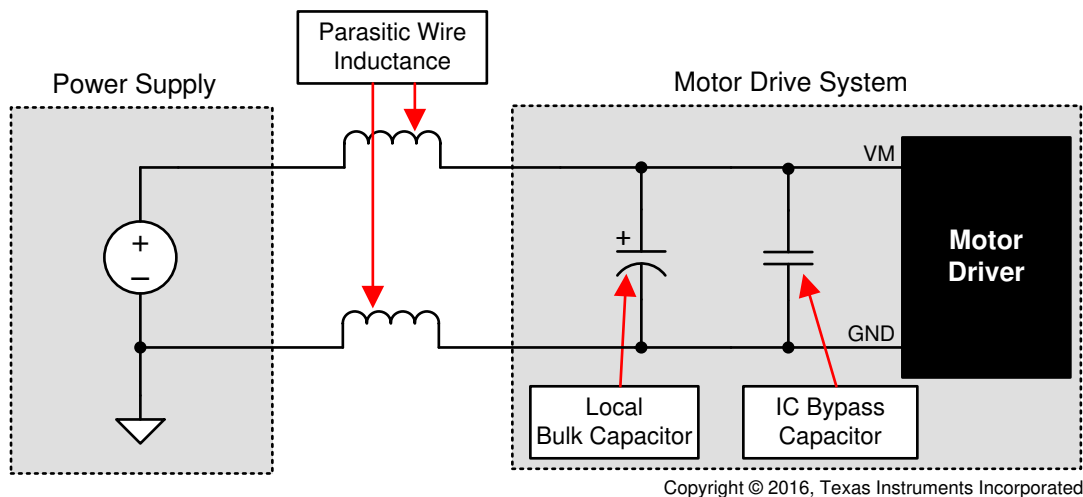
The amount of local capacitance needed depends on a variety of factors, including:

- The highest current required by the motor system
- The power supply's capacitance and ability to source current
- The amount of parasitic inductance between the power supply and motor system
- The acceptable voltage ripple
- The type of motor used (brushed DC, brushless DC, stepper)
- The motor braking method

The inductance between the power supply and motor drive system will limit the rate current can change from the power supply. If the local bulk capacitance is too small, the system will respond to excessive current demands or dumps from the motor with a change in voltage. When adequate bulk capacitance is used, the motor voltage remains stable and high current can be quickly supplied.

The data sheet generally provides a recommended value, but system-level testing is required to determine the appropriate sized bulk capacitor.

The voltage rating for bulk capacitors should be higher than the operating voltage, to provide margin for cases when the motor transfers energy to the supply.



**Figure 8-23. Example Setup of Motor Drive System With External Power Supply**

## 8.4 Layout

### 8.4.1 Layout Guidelines

The VM pin should be bypassed to GND using a low-ESR ceramic bypass capacitor with a recommended value of 0.01  $\mu\text{F}$  rated for VM. This capacitor should be placed as close to the VM pin as possible with a thick trace or ground plane connection to the device GND pin.

The VM pin must be bypassed to ground using a bulk capacitor rated for VM. This component can be an electrolytic capacitor.

A low-ESR ceramic capacitor must be placed in between the CPL and CPH pins. A value of 0.022  $\mu\text{F}$  rated for VM is recommended. Place this component as close to the pins as possible.

A low-ESR ceramic capacitor must be placed in between the VM and VCP pins. A value of 0.22  $\mu\text{F}$  rated for 16 V is recommended. Place this component as close to the pins as possible.

Bypass the DVDD pin to ground with a low-ESR ceramic capacitor. A value of 0.47  $\mu\text{F}$  rated for 6.3 V is recommended. Place this bypassing capacitor as close to the pin as possible.

The thermal PAD must be connected to system ground.

### 8.4.2 Layout Example

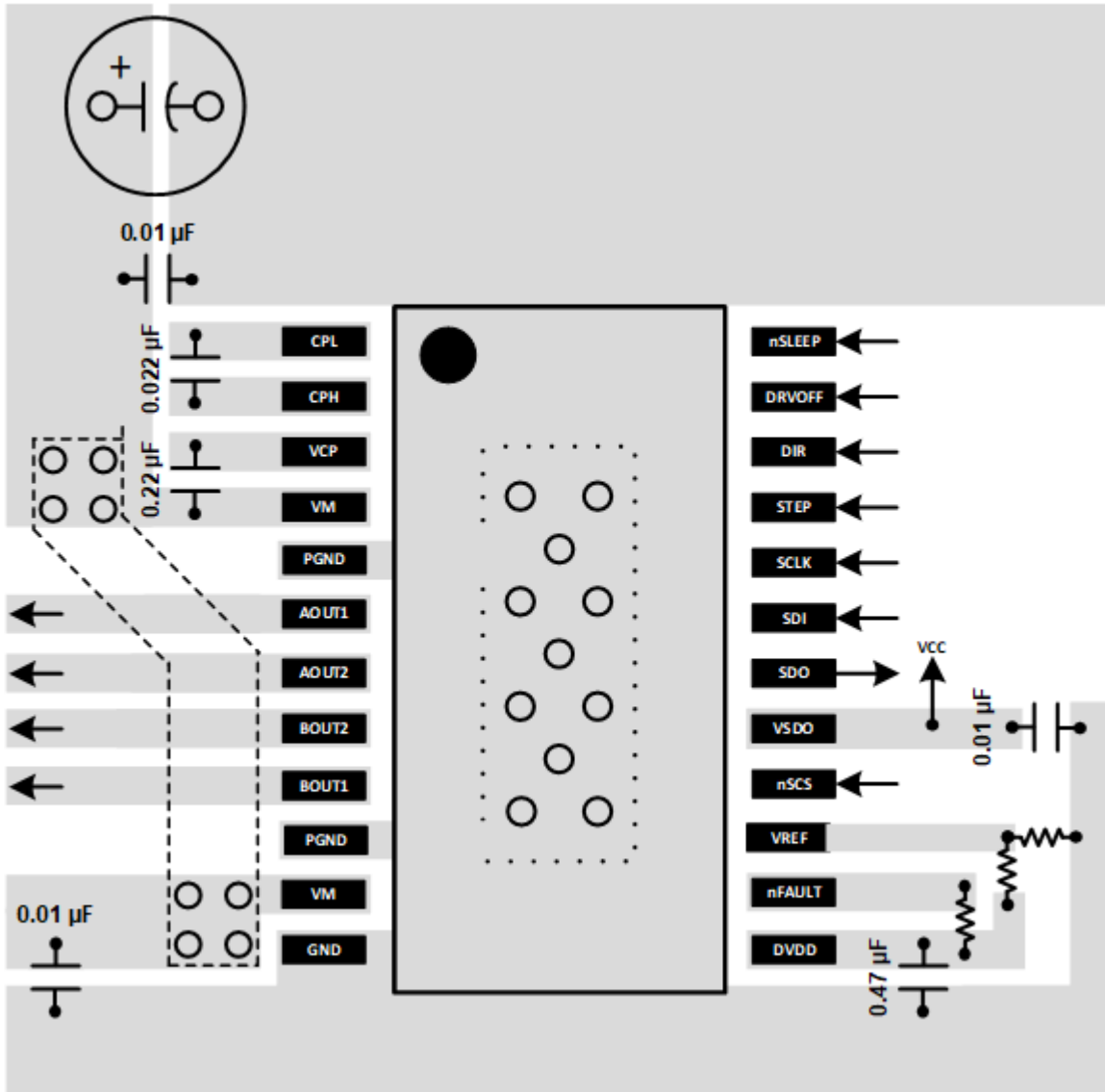


Figure 8-24. HTSSOP Layout Recommendation

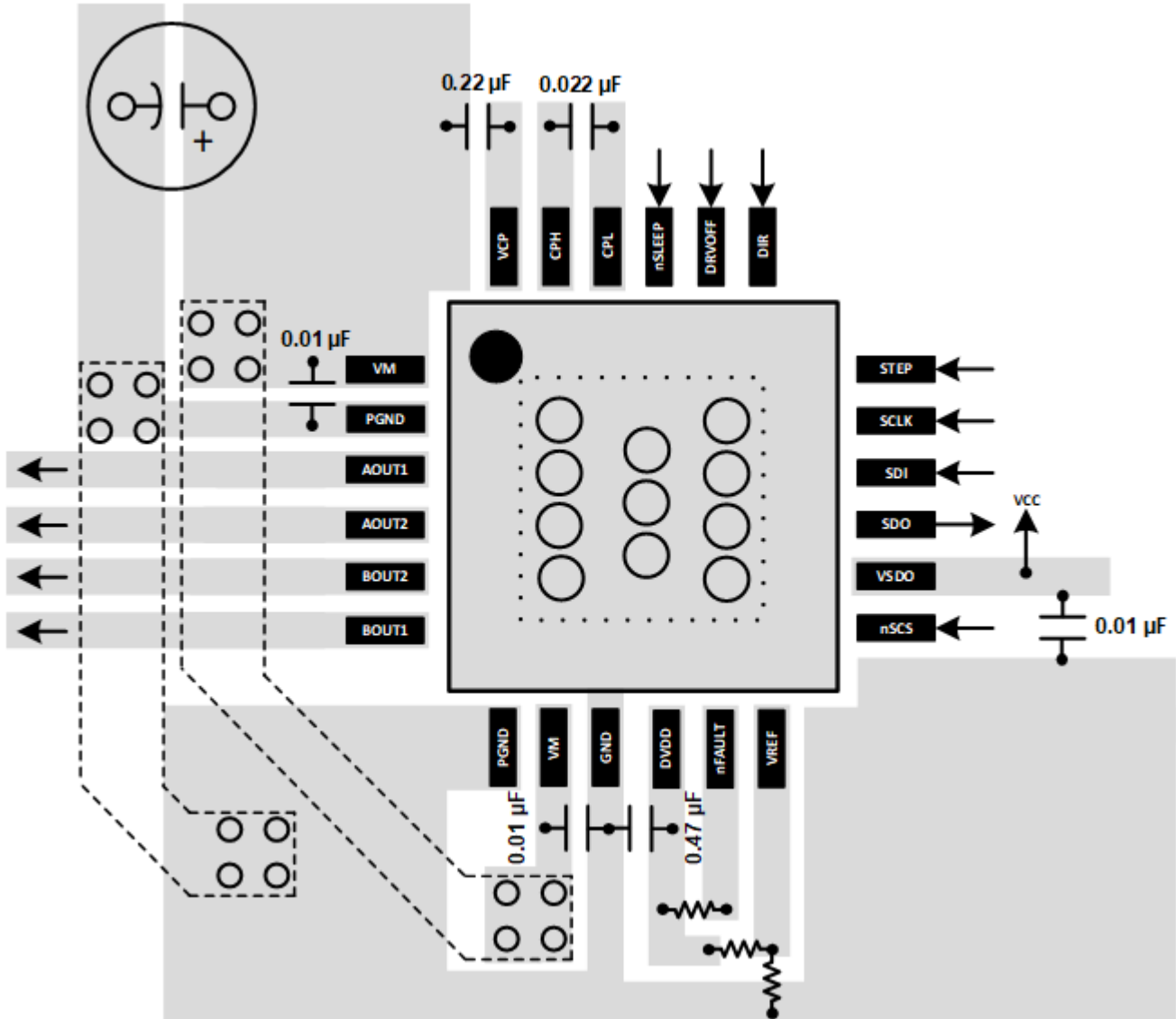


Figure 8-25. QFN Layout Recommendation

## 9 Device and Documentation Support

### 9.1 Documentation Support

#### 9.1.1 Related Documentation

For related documentation see the following:

- Texas Instruments, [Sensorless Stall Detection With the DRV8889-Q1 application report](#)
- Texas Instruments, [DRV8889-Q1, DRV8889A-Q1 Functional Safety FIT Rate, FMD and Pin FMA](#)
- Texas Instruments, [Calculating Motor Driver Power Dissipation application report](#)
- Texas Instruments, [Current Recirculation and Decay Modes application report](#)
- Texas Instruments, [How AutoTune™ regulates current in stepper motors white paper](#)
- Texas Instruments, [Industrial Motor Drive Solution Guide](#)
- Texas Instruments, [PowerPAD™ Made Easy application report](#)
- Texas Instruments, [PowerPAD™ Thermally Enhanced Package application report](#)
- Texas Instruments, [Stepper motors made easy with AutoTune™ white paper](#)
- Texas Instruments, [Understanding Motor Driver Current Ratings application report](#)
- Texas Instruments, [Motor Drives Layout Guide application report](#)
- Texas Instruments, [DRV8889-Q1 Evaluation Module \(EVM\) tool folder](#)

### 9.2 Receiving Notification of Documentation Updates

To receive notification of documentation updates, navigate to the device product folder on [ti.com](http://ti.com). Click on *Notifications* to register and receive a weekly digest of any product information that has changed. For change details, review the revision history included in any revised document.

### 9.3 Support Resources

[TI E2E™ support forums](#) are an engineer's go-to source for fast, verified answers and design help — straight from the experts. Search existing answers or ask your own question to get the quick design help you need.

Linked content is provided "AS IS" by the respective contributors. They do not constitute TI specifications and do not necessarily reflect TI's views; see TI's [Terms of Use](#).

### 9.4 Trademarks

TI E2E™ is a trademark of Texas Instruments.

All trademarks are the property of their respective owners.

### 9.5 Electrostatic Discharge Caution



This integrated circuit can be damaged by ESD. Texas Instruments recommends that all integrated circuits be handled with appropriate precautions. Failure to observe proper handling and installation procedures can cause damage.

ESD damage can range from subtle performance degradation to complete device failure. Precision integrated circuits may be more susceptible to damage because very small parametric changes could cause the device not to meet its published specifications.

### 9.6 Glossary

[TI Glossary](#) This glossary lists and explains terms, acronyms, and definitions.

## 10 Revision History

NOTE: Page numbers for previous revisions may differ from page numbers in the current version.

Changes from Revision D (April 2021) to Revision E (November 2025)	Page
• t(HI_nSCS) updated to show the correct value for MIN time and remove the wrong value for MAX time. ....	9
• REV_ID bits in CTRL8 register updated to reflect the DRV8889A indicator.....	45

<b>Changes from Revision C (August 2020) to Revision D (April 2021)</b>	<b>Page</b>
• Added Functional Safety information.....	1
• Typo corrections in <i>Absolute Maximum Ratings</i> section.....	5
• Updated <i>Full Step with 100% Current</i> table.....	16
• Removed duplicate package drawings.....	71

---

<b>Changes from Revision B (January 2020) to Revision C (August 2020)</b>	<b>Page</b>
• Added wake-up time and turn-on time specs for DRV8889A-Q1.....	7
• Added open-load detection time specs for DRV8889A-Q1.....	7
• Added blanking time details for DRV8889A-Q1 .....	30
• Fixed typo for OTW fault.....	37
• Added Memory Map details for DRV8889A-Q1 .....	45
• DIS_OUT bit details for DRV8889A-Q1 in <a href="#">Section 7.7</a> .....	45
• OL_TIME and EN_SR_BLANK bit details for DRV8889A-Q1 <a href="#">Section 7.10</a> .....	45
• Fixed typo in switching loss calculations.....	60

---

<b>Changes from Revision A (December 2019) to Revision B (January 2020)</b>	<b>Page</b>
• Changed R-C time constant for low-pass filter in <a href="#">Section 6.3.4</a> .....	18
• Added table to <a href="#">Section 6.4.2</a> .....	38
• Added new scope shot to <a href="#">Section 8.2.3</a> .....	58
• Added data on thermal parameters in <a href="#">Section 8.2.4.3</a> .....	63

---

<b>Changes from Revision * (November 2019) to Revision A (December 2019)</b>	<b>Page</b>
• Changed Device status to Production Data .....	1

---

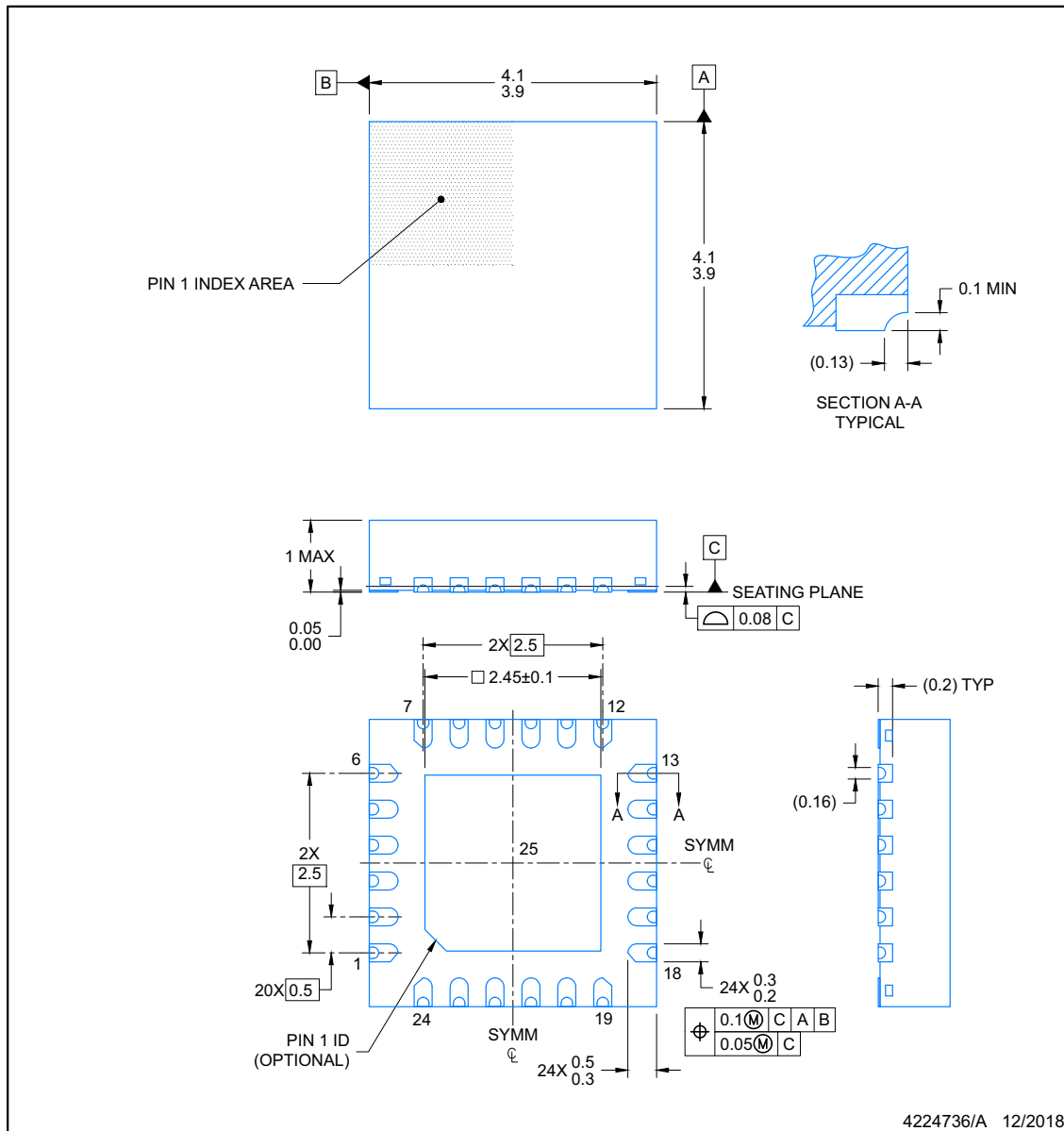
## 11 Mechanical, Packaging, and Orderable Information

For the device mechanical, packaging, and orderable information, refer to the *Mechanical, Packaging, and Orderable Information* section of the data sheet available in the [DRV8889-Q1 product folder](#)

**RGE0024N**

**PACKAGE OUTLINE**  
**VQFN - 1 mm max height**

PLASTIC QUAD FLATPACK-NO LEAD



NOTES:

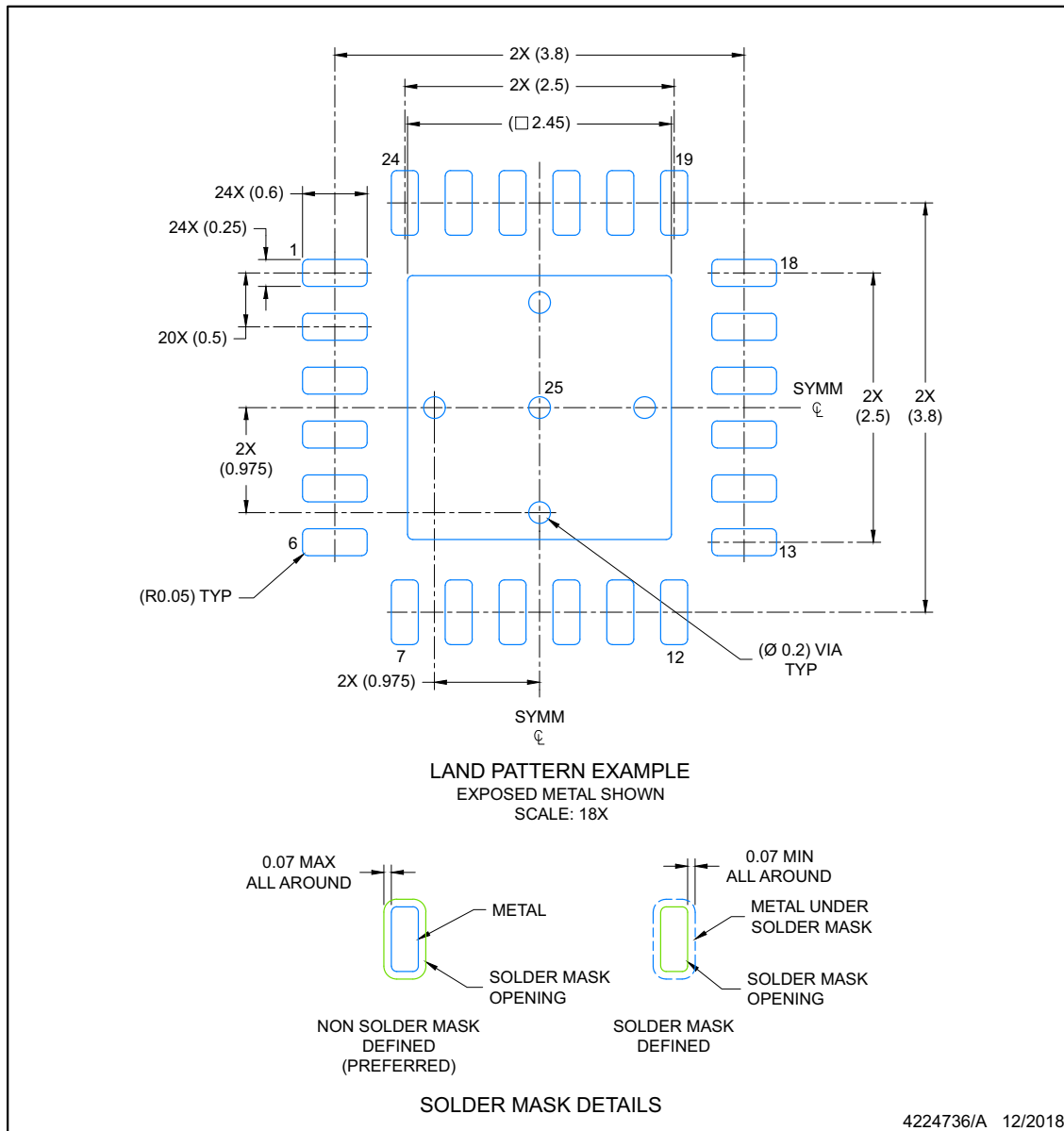
1. All linear dimensions are in millimeters. Any dimensions in parenthesis are for reference only. Dimensioning and tolerancing per ASME Y14.5M.
2. This drawing is subject to change without notice.
3. The package thermal pad must be soldered to the printed circuit board for optimal thermal and mechanical performance.

## EXAMPLE BOARD LAYOUT

### RGE0024N

### VQFN - 1 mm max height

PLASTIC QUAD FLATPACK-NO LEAD



NOTES: (continued)

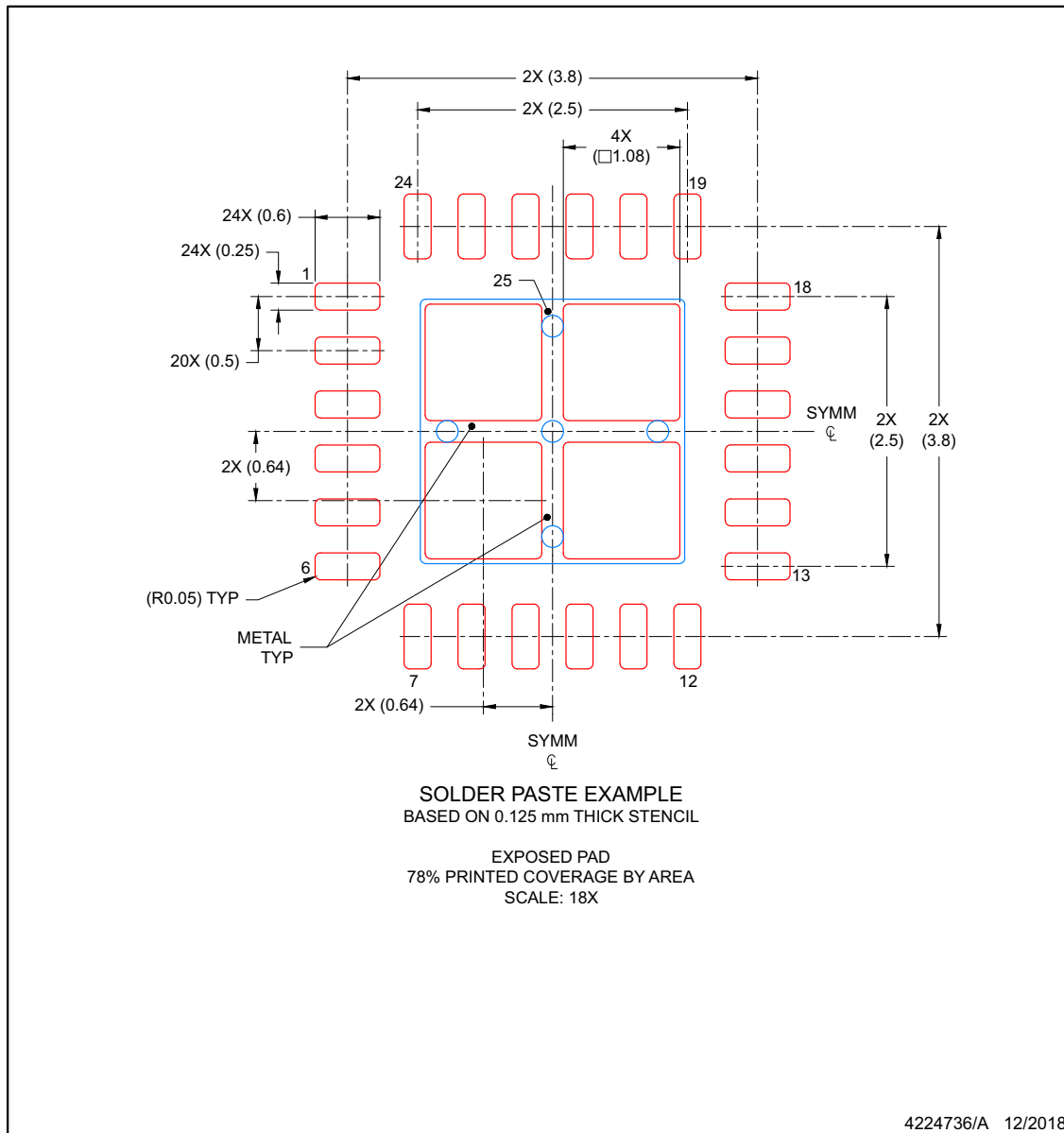
- This package is designed to be soldered to a thermal pad on the board. For more information, see Texas Instruments literature number SLUA271 ([www.ti.com/lit/sluea271](http://www.ti.com/lit/sluea271)).
- Vias are optional depending on application, refer to device data sheet. If any vias are implemented, refer to their locations shown on this view. It is recommended that vias under paste be filled, plugged or tented.

## EXAMPLE STENCIL DESIGN

**RGE0024N**

**VQFN - 1 mm max height**

PLASTIC QUAD FLATPACK-NO LEAD



NOTES: (continued)

6. Laser cutting apertures with trapezoidal walls and rounded corners may offer better paste release. IPC-7525 may have alternate design recommendations.

**PACKAGING INFORMATION**

Orderable part number	Status (1)	Material type (2)	Package   Pins	Package qty   Carrier	RoHS (3)	Lead finish/ Ball material (4)	MSL rating/ Peak reflow (5)	Op temp (°C)	Part marking (6)
<a href="#">DRV8889AQPWPRQ1</a>	Active	Production	HTSSOP (PWP)   24	2500   LARGE T&R	Yes	NIPDAU	Level-3-260C-168 HR	-40 to 125	DRV8889A
DRV8889AQPWPRQ1.A	Active	Production	HTSSOP (PWP)   24	2500   LARGE T&R	Yes	NIPDAU	Level-3-260C-168 HR	-40 to 125	DRV8889A
<a href="#">DRV8889AQWRGERQ1</a>	Active	Production	VQFN (RGE)   24	3000   LARGE T&R	Yes	NIPDAU	Level-2-260C-1 YEAR	-40 to 125	DRV 8889A
DRV8889AQWRGERQ1.A	Active	Production	VQFN (RGE)   24	3000   LARGE T&R	Yes	NIPDAU	Level-2-260C-1 YEAR	-40 to 125	DRV 8889A
<a href="#">DRV8889QPWPRQ1</a>	Active	Production	HTSSOP (PWP)   24	2000   LARGE T&R	Yes	NIPDAU	Level-3-260C-168 HR	-40 to 125	DRV8889
DRV8889QPWPRQ1.A	Active	Production	HTSSOP (PWP)   24	2000   LARGE T&R	Yes	NIPDAU	Level-3-260C-168 HR	-40 to 125	DRV8889
<a href="#">DRV8889QWRGERQ1</a>	Active	Production	VQFN (RGE)   24	3000   LARGE T&R	Yes	NIPDAU	Level-2-260C-1 YEAR	-40 to 125	DRV 8889
DRV8889QWRGERQ1.A	Active	Production	VQFN (RGE)   24	3000   LARGE T&R	Yes	NIPDAU	Level-2-260C-1 YEAR	-40 to 125	DRV 8889

<sup>(1)</sup> **Status:** For more details on status, see our [product life cycle](#).

<sup>(2)</sup> **Material type:** When designated, preproduction parts are prototypes/experimental devices, and are not yet approved or released for full production. Testing and final process, including without limitation quality assurance, reliability performance testing, and/or process qualification, may not yet be complete, and this item is subject to further changes or possible discontinuation. If available for ordering, purchases will be subject to an additional waiver at checkout, and are intended for early internal evaluation purposes only. These items are sold without warranties of any kind.

<sup>(3)</sup> **RoHS values:** Yes, No, RoHS Exempt. See the [TI RoHS Statement](#) for additional information and value definition.

<sup>(4)</sup> **Lead finish/Ball material:** Parts may have multiple material finish options. Finish options are separated by a vertical ruled line. Lead finish/Ball material values may wrap to two lines if the finish value exceeds the maximum column width.

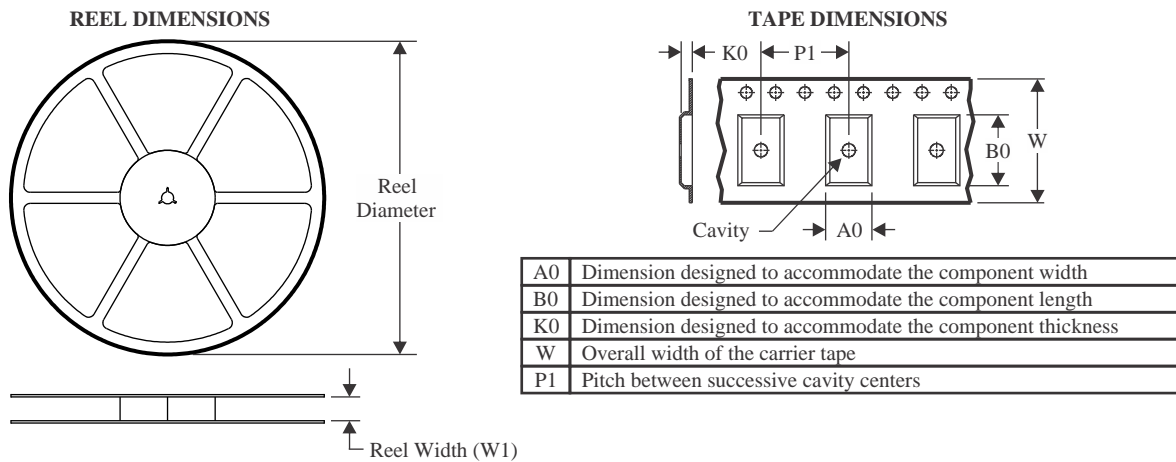
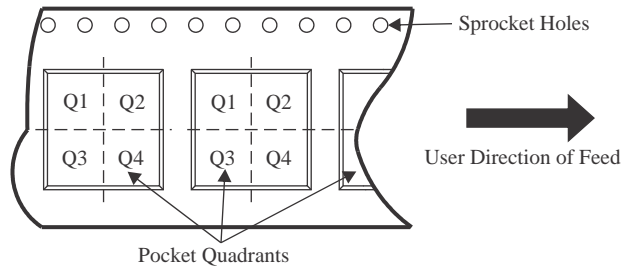
<sup>(5)</sup> **MSL rating/Peak reflow:** The moisture sensitivity level ratings and peak solder (reflow) temperatures. In the event that a part has multiple moisture sensitivity ratings, only the lowest level per JEDEC standards is shown. Refer to the shipping label for the actual reflow temperature that will be used to mount the part to the printed circuit board.

<sup>(6)</sup> **Part marking:** There may be an additional marking, which relates to the logo, the lot trace code information, or the environmental category of the part.

Multiple part markings will be inside parentheses. Only one part marking contained in parentheses and separated by a "-" will appear on a part. If a line is indented then it is a continuation of the previous line and the two combined represent the entire part marking for that device.

**Important Information and Disclaimer:** The information provided on this page represents TI's knowledge and belief as of the date that it is provided. TI bases its knowledge and belief on information provided by third parties, and makes no representation or warranty as to the accuracy of such information. Efforts are underway to better integrate information from third parties. TI has taken and continues to take reasonable steps to provide representative and accurate information but may not have conducted destructive testing or chemical analysis on incoming materials and chemicals. TI and TI suppliers consider certain information to be proprietary, and thus CAS numbers and other limited information may not be available for release.

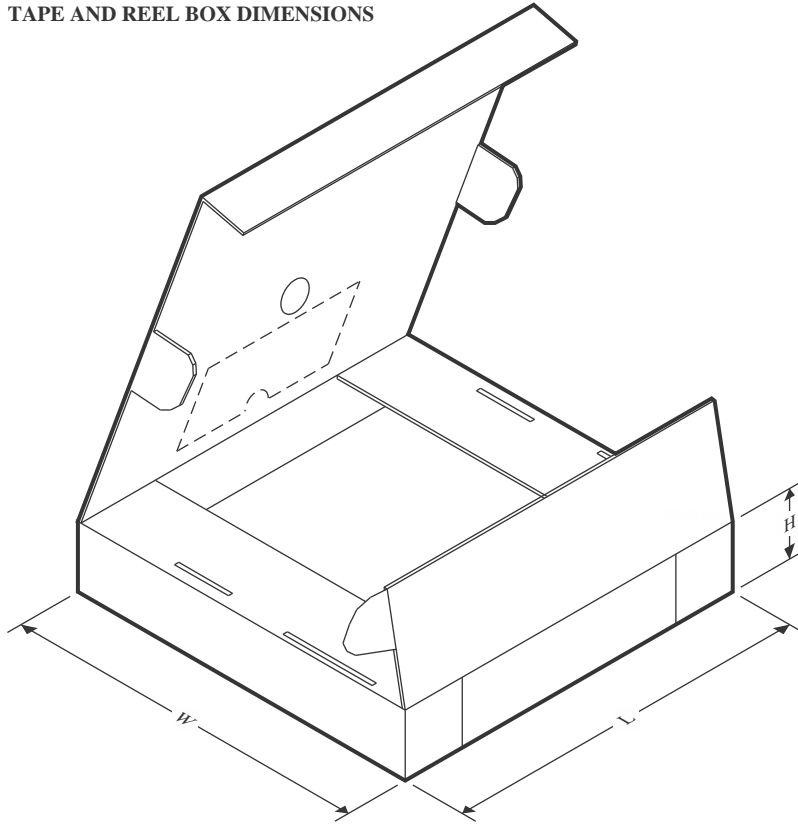
In no event shall TI's liability arising out of such information exceed the total purchase price of the TI part(s) at issue in this document sold by TI to Customer on an annual basis.

**TAPE AND REEL INFORMATION**

**QUADRANT ASSIGNMENTS FOR PIN 1 ORIENTATION IN TAPE**


\*All dimensions are nominal

Device	Package Type	Package Drawing	Pins	SPQ	Reel Diameter (mm)	Reel Width W1 (mm)	A0 (mm)	B0 (mm)	K0 (mm)	P1 (mm)	W (mm)	Pin1 Quadrant
DRV8889AQPWPRQ1	HTSSOP	PWP	24	2500	330.0	16.4	6.95	8.3	1.6	8.0	16.0	Q1
DRV8889AQRGERQ1	VQFN	RGE	24	3000	330.0	12.4	4.25	4.25	1.15	8.0	12.0	Q2
DRV8889QPWPRQ1	HTSSOP	PWP	24	2000	330.0	16.4	6.95	8.3	1.6	8.0	16.0	Q1
DRV8889QQRGERQ1	VQFN	RGE	24	3000	330.0	12.4	4.25	4.25	1.15	8.0	12.0	Q2

## TAPE AND REEL BOX DIMENSIONS



\*All dimensions are nominal

Device	Package Type	Package Drawing	Pins	SPQ	Length (mm)	Width (mm)	Height (mm)
DRV8889AQPWPRQ1	HTSSOP	PWP	24	2500	353.0	353.0	32.0
DRV8889AQWRGERQ1	VQFN	RGE	24	3000	367.0	367.0	35.0
DRV8889QPWPRQ1	HTSSOP	PWP	24	2000	353.0	353.0	32.0
DRV8889QWRGERQ1	VQFN	RGE	24	3000	367.0	367.0	35.0

## GENERIC PACKAGE VIEW

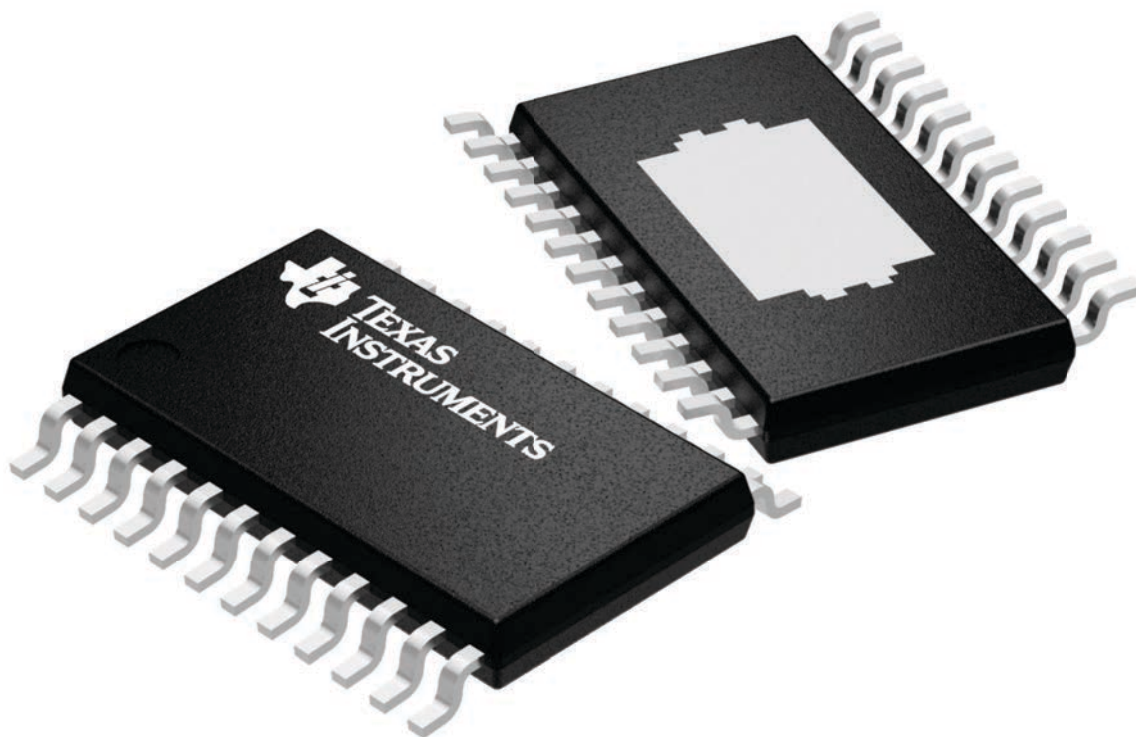
**PWP 24**

**PowerPAD™ TSSOP - 1.2 mm max height**

4.4 x 7.6, 0.65 mm pitch

PLASTIC SMALL OUTLINE

This image is a representation of the package family, actual package may vary.  
Refer to the product data sheet for package details.



4224742/B

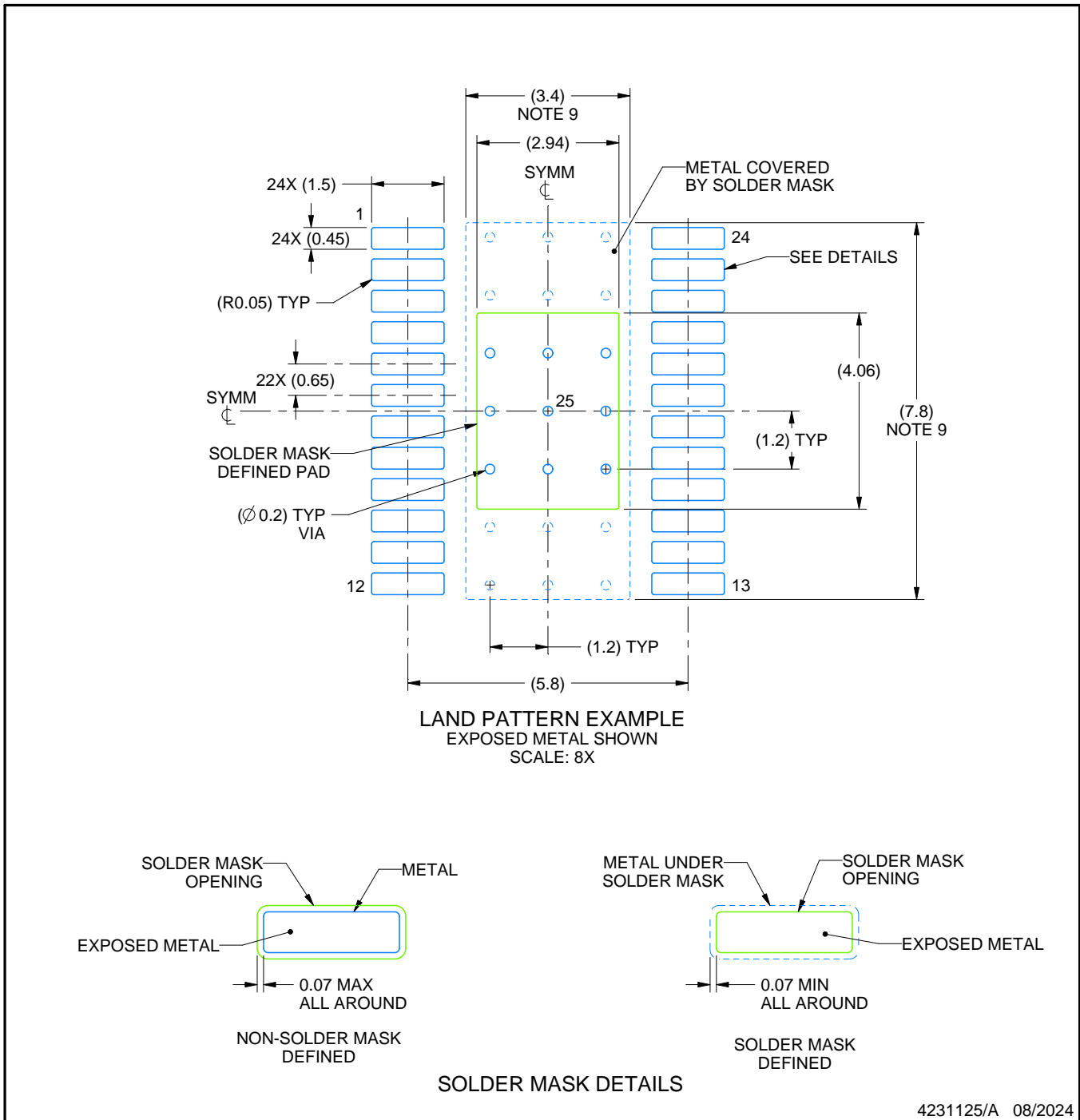


# EXAMPLE BOARD LAYOUT

PWP0024W

PowerPAD™ TSSOP - 1.2 mm max height

SMALL OUTLINE PACKAGE



NOTES: (continued)

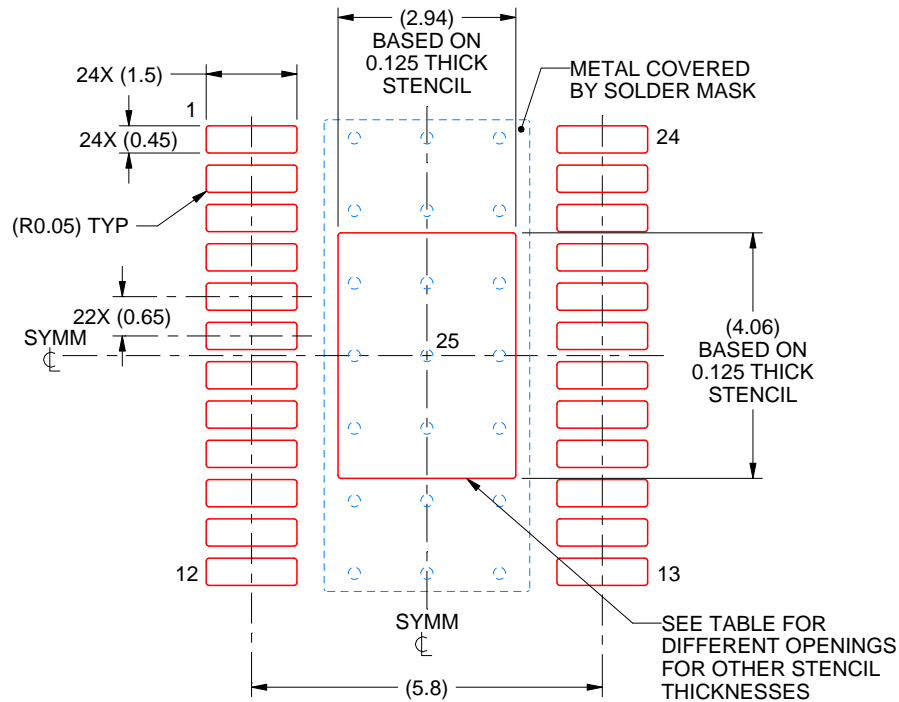
6. Publication IPC-7351 may have alternate designs.
7. Solder mask tolerances between and around signal pads can vary based on board fabrication site.
8. This package is designed to be soldered to a thermal pad on the board. For more information, see Texas Instruments literature numbers SLMA002 ([www.ti.com/lit/slma002](http://www.ti.com/lit/slma002)) and SLMA004 ([www.ti.com/lit/slma004](http://www.ti.com/lit/slma004)).
9. Size of metal pad may vary due to creepage requirement.
10. Vias are optional depending on application, refer to device data sheet. It is recommended that vias under paste be filled, plugged or tented.

# EXAMPLE STENCIL DESIGN

PWP0024W

PowerPAD™ TSSOP - 1.2 mm max height

SMALL OUTLINE PACKAGE



SOLDER PASTE EXAMPLE  
 BASED ON 0.125 mm THICK STENCIL  
 SCALE: 8X

STENCIL THICKNESS	SOLDER STENCIL OPENING
0.1	3.29 X 4.54
0.125	2.94 X 4.06 (SHOWN)
0.15	2.68 X 3.71
0.175	2.48 X 3.43

4231125/A 08/2024

NOTES: (continued)

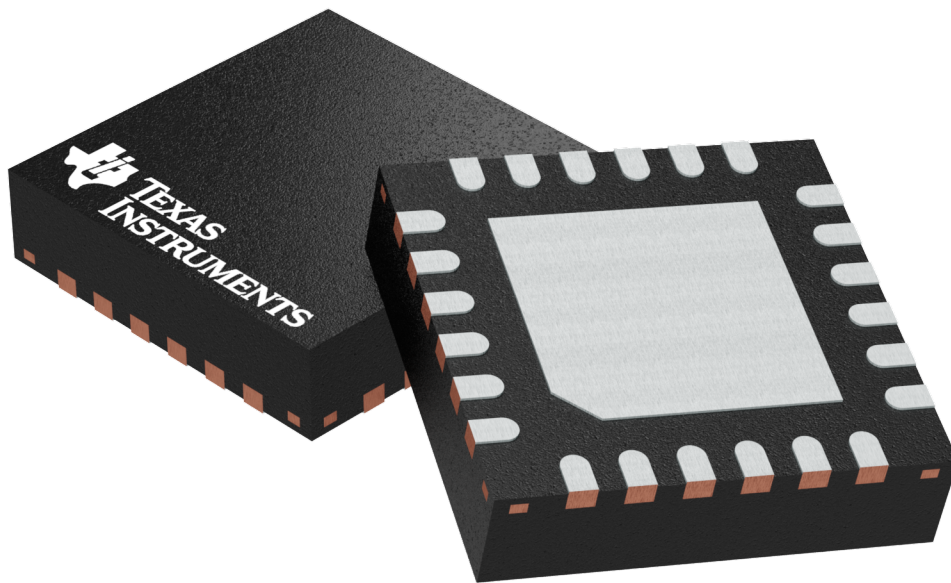
11. Laser cutting apertures with trapezoidal walls and rounded corners may offer better paste release. IPC-7525 may have alternate design recommendations.
12. Board assembly site may have different recommendations for stencil design.

**RGE 24**

**GENERIC PACKAGE VIEW**

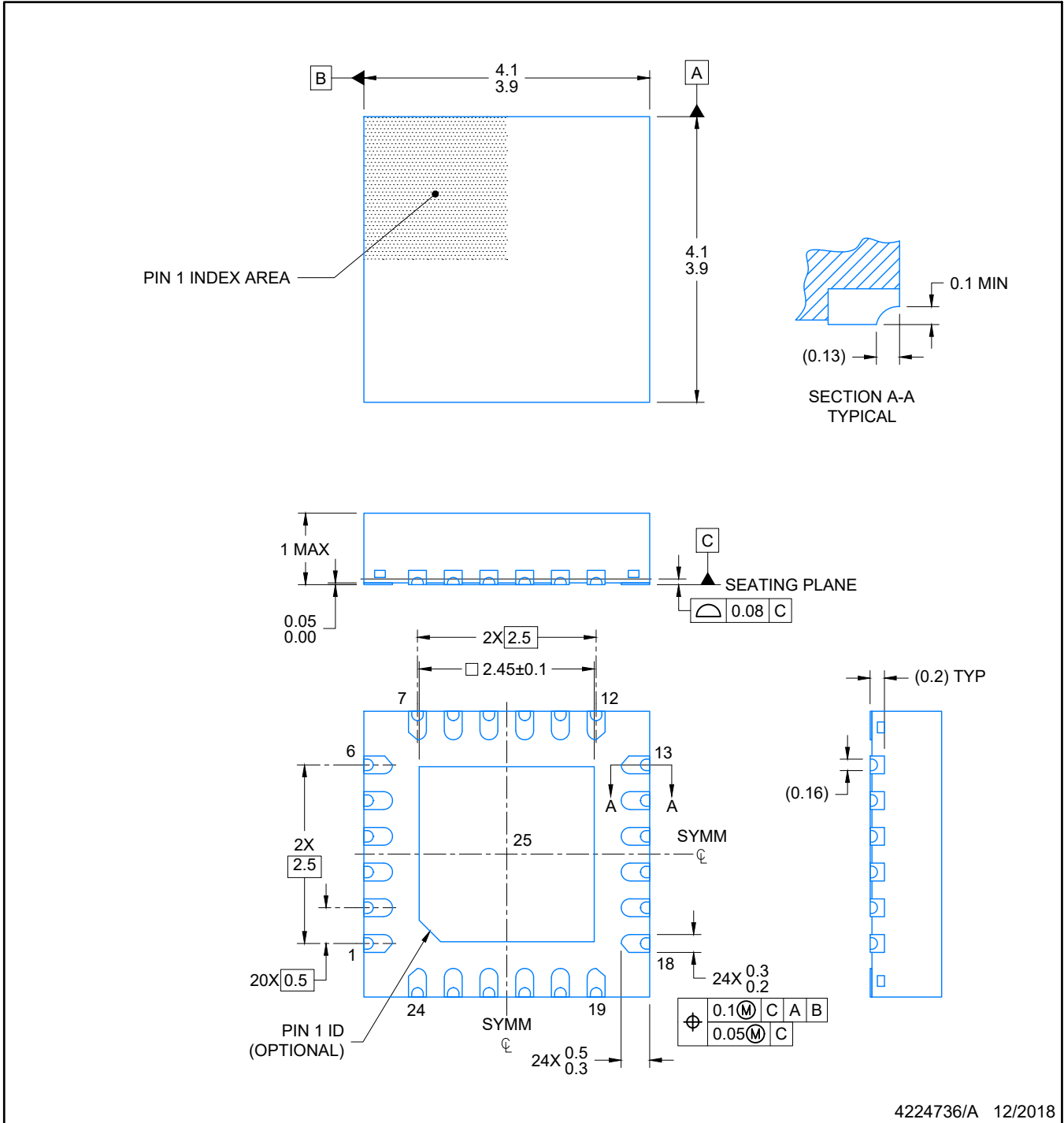
**VQFN - 1 mm max height**

PLASTIC QUAD FLATPACK - NO LEAD



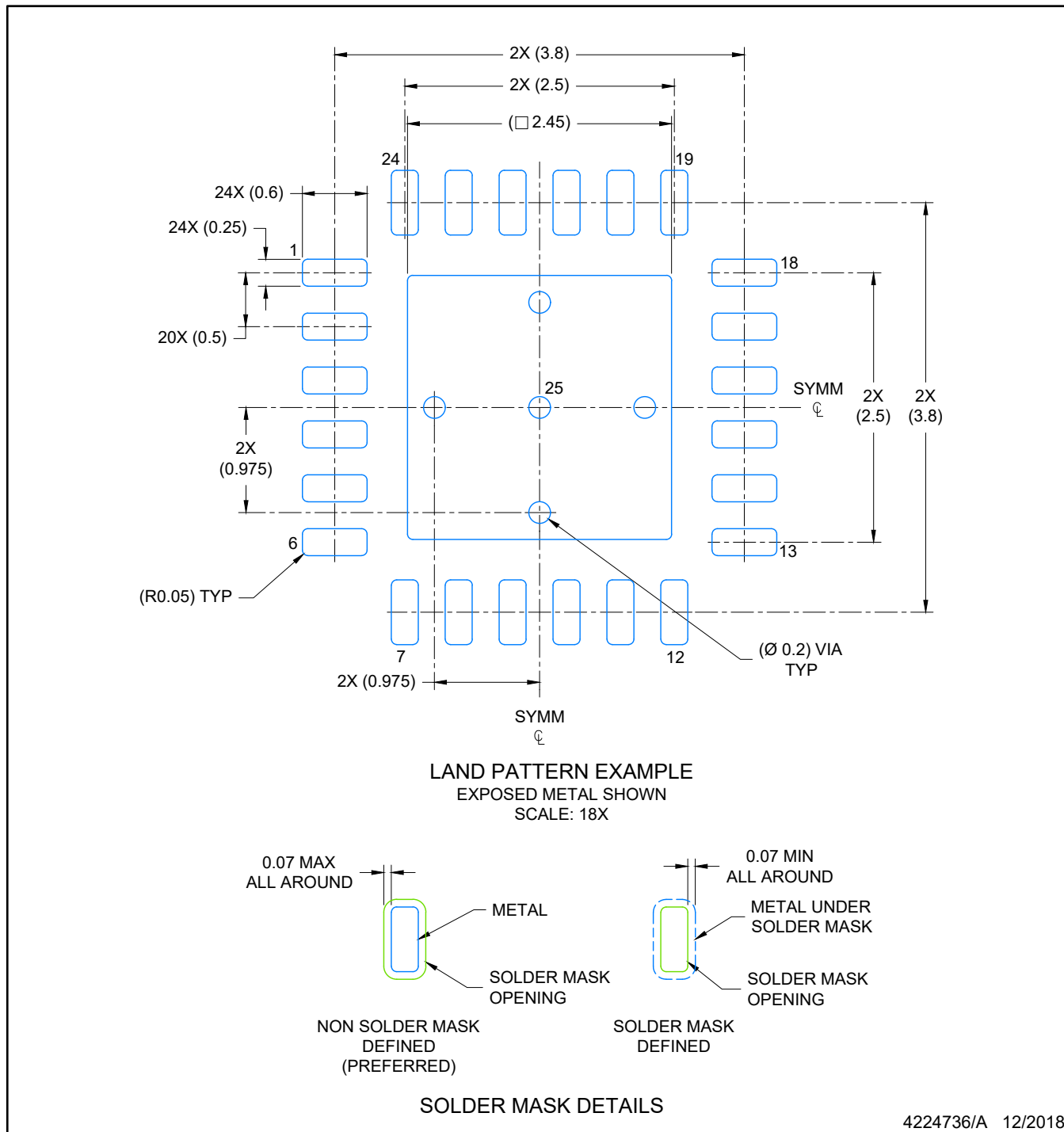
Images above are just a representation of the package family, actual package may vary.  
Refer to the product data sheet for package details.

4204104/H



NOTES:

1. All linear dimensions are in millimeters. Any dimensions in parenthesis are for reference only. Dimensioning and tolerancing per ASME Y14.5M.
2. This drawing is subject to change without notice.
3. The package thermal pad must be soldered to the printed circuit board for optimal thermal and mechanical performance.



NOTES: (continued)

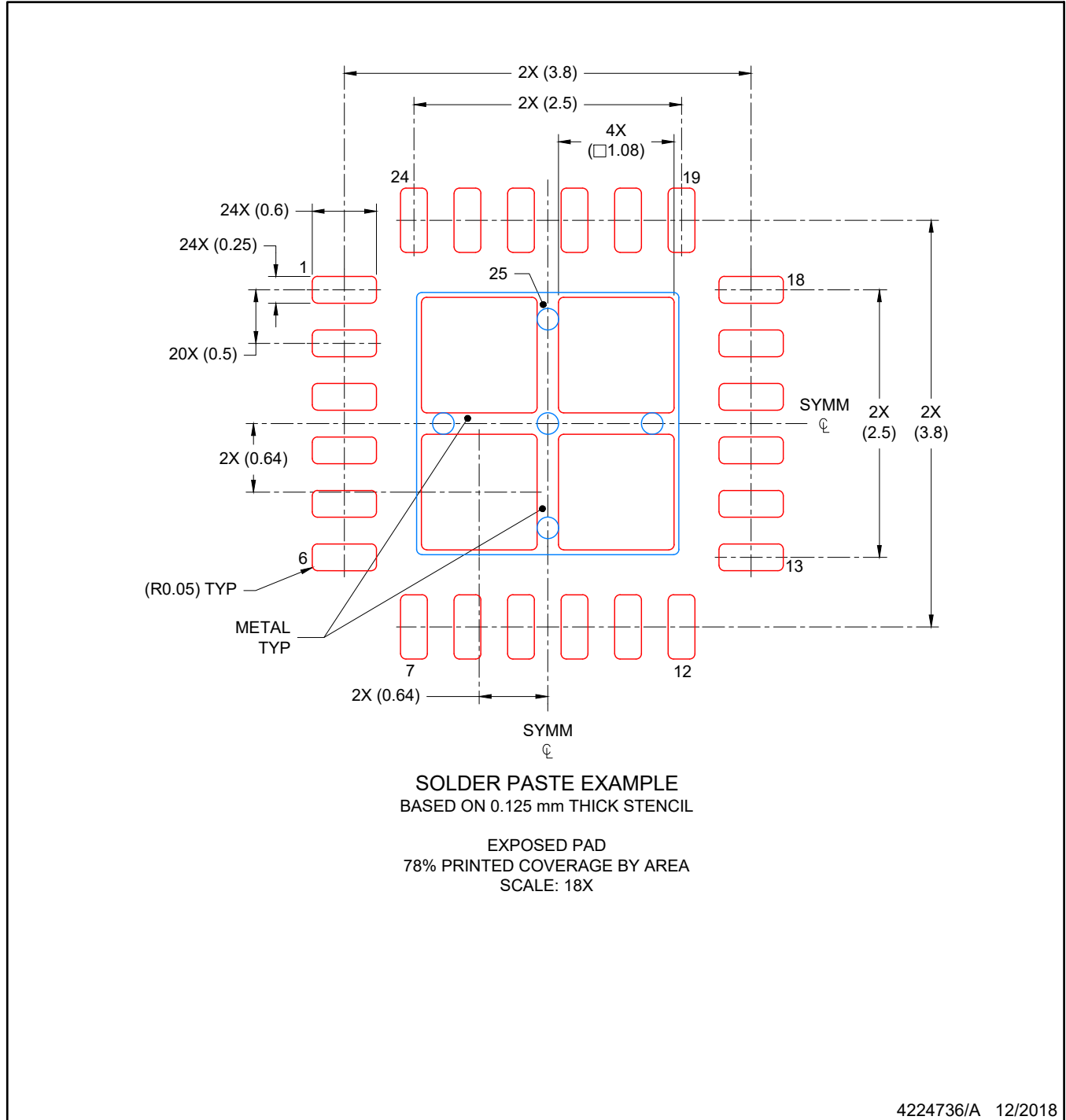
4. This package is designed to be soldered to a thermal pad on the board. For more information, see Texas Instruments literature number SLUA271 ([www.ti.com/lit/sluea271](http://www.ti.com/lit/sluea271)).
5. Vias are optional depending on application, refer to device data sheet. If any vias are implemented, refer to their locations shown on this view. It is recommended that vias under paste be filled, plugged or tented.

# EXAMPLE STENCIL DESIGN

RGE0024N

VQFN - 1 mm max height

PLASTIC QUAD FLATPACK-NO LEAD



NOTES: (continued)

6. Laser cutting apertures with trapezoidal walls and rounded corners may offer better paste release. IPC-7525 may have alternate design recommendations.

## IMPORTANT NOTICE AND DISCLAIMER

TI PROVIDES TECHNICAL AND RELIABILITY DATA (INCLUDING DATASHEETS), DESIGN RESOURCES (INCLUDING REFERENCE DESIGNS), APPLICATION OR OTHER DESIGN ADVICE, WEB TOOLS, SAFETY INFORMATION, AND OTHER RESOURCES "AS IS" AND WITH ALL FAULTS, AND DISCLAIMS ALL WARRANTIES, EXPRESS AND IMPLIED, INCLUDING WITHOUT LIMITATION ANY IMPLIED WARRANTIES OF MERCHANTABILITY, FITNESS FOR A PARTICULAR PURPOSE OR NON-INFRINGEMENT OF THIRD PARTY INTELLECTUAL PROPERTY RIGHTS.

These resources are intended for skilled developers designing with TI products. You are solely responsible for (1) selecting the appropriate TI products for your application, (2) designing, validating and testing your application, and (3) ensuring your application meets applicable standards, and any other safety, security, regulatory or other requirements.

These resources are subject to change without notice. TI grants you permission to use these resources only for development of an application that uses the TI products described in the resource. Other reproduction and display of these resources is prohibited. No license is granted to any other TI intellectual property right or to any third party intellectual property right. TI disclaims responsibility for, and you fully indemnify TI and its representatives against any claims, damages, costs, losses, and liabilities arising out of your use of these resources.

TI's products are provided subject to [TI's Terms of Sale](#), [TI's General Quality Guidelines](#), or other applicable terms available either on [ti.com](#) or provided in conjunction with such TI products. TI's provision of these resources does not expand or otherwise alter TI's applicable warranties or warranty disclaimers for TI products. Unless TI explicitly designates a product as custom or customer-specified, TI products are standard, catalog, general purpose devices.

TI objects to and rejects any additional or different terms you may propose.

Copyright © 2026, Texas Instruments Incorporated

Last updated 10/2025