

ADS816x 8-Channel, 16-Bit, 1MSPS, SAR ADC With Direct Sensor Interface

1 Features

- Compact low-power data acquisition system:
 - MUX breakout enables single external driver amplifier
 - 16-bit SAR ADC
 - Low-drift integrated reference and buffer
 - $0.5 \times V_{REF}$ output for analog input DC biasing
- Excellent AC and DC performance:
 - SNR: 92dB, THD: –110dB
 - INL: ± 0.3 LSB, 16-bit no missing codes
- Multiplexer with channel sequencer:
 - Multiple channel-sequencing options:
 - Manual mode, on-the-fly mode, auto sequence mode, custom channel sequencing
 - Fast response time with on-the-fly mode
- System monitoring features:
 - Per channel programmable window comparator
 - False trigger avoidance with programmable hysteresis
- Enhanced-SPI digital interface:
 - 1MSPS throughput with 16MHz SCLK
 - High-speed, 50MHz digital interface
- Wide operating range:
 - External V_{REF} input range: 2.5V to 5V
 - AVDD from 3V to 5.5V
 - DVDD from 1.65V to 5.5V
 - -40°C to $+125^{\circ}\text{C}$ temperature range

2 Applications

- [Chemistry, gas analyzers](#)
- [Anesthesia delivery systems](#)
- [Mixed modules \(AI, AO, DI, DO\)](#)
- [Intra-DC interconnects \(metro\)](#)

3 Description

The ADS816x is a family of 16-bit, 8-channel, high-precision successive approximation register (SAR) analog-to-digital converters (ADCs). The ADCs operate from a single 5V supply with a 1MSPS (ADS8168), 500kSPS (ADS8167), and 250kSPS (ADS8166) total throughput.

The input multiplexer supports extended settling time, which makes driving the analog inputs easier. The output of the multiplexer and ADC analog inputs are available as device pins. This configuration allows one ADC driver op amp to be used for all eight analog inputs of the multiplexer.

The ADS816x features a digital window comparator with programmable high and low alarm thresholds per analog input channel. The single op-amp solution with programmable alarm thresholds enables low power, low cost, and smallest form-factor applications.

Package Information

PART NUMBER	PACKAGE ⁽¹⁾	PACKAGE SIZE ⁽²⁾
ADS816x	RHB (VQFN, 32)	5mm × 5mm

- (1) For more information, see the [Mechanical, Packaging, and Orderable Information](#).
- (2) The package size (length × width) is a nominal value and includes pins, where applicable.

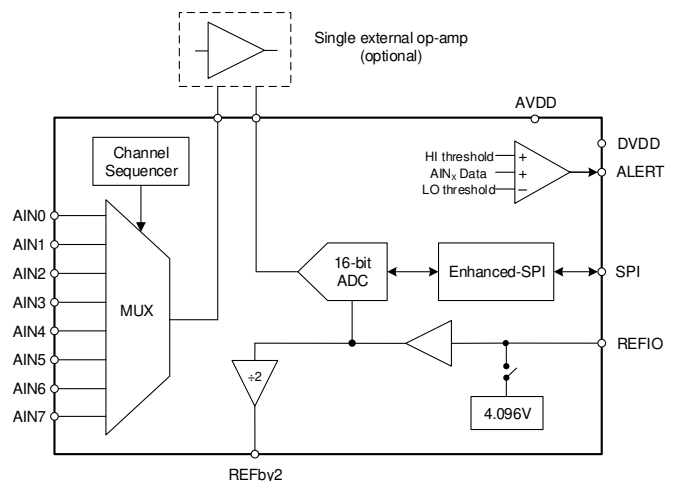

ADS816x Block Diagram



Table of Contents

1 Features	1	7.1 Interface and Hardware Configuration Registers.....	43
2 Applications	1	7.2 Device Calibration Registers.....	48
3 Description	1	7.3 Analog Input Configuration Registers.....	51
4 Pin Configuration and Functions	3	7.4 Channel Sequence Configuration Registers Map.....	53
5 Specifications	5	7.5 Digital Window Comparator Configuration Registers Map.....	60
5.1 Absolute Maximum Ratings.....	5	8 Application and Implementation	68
5.2 ESD Ratings.....	5	8.1 Application Information.....	68
5.3 Thermal Information.....	5	8.2 Typical Applications.....	70
5.4 Recommended Operating Conditions.....	6	8.3 Layout.....	72
5.5 Electrical Characteristics.....	7	9 Device and Documentation Support	75
5.6 Timing Requirements.....	9	9.1 Documentation Support.....	75
5.7 Switching Characteristics.....	10	9.2 Receiving Notification of Documentation Updates...	75
5.8 Timing Diagrams.....	11	9.3 Support Resources.....	75
5.9 Typical Characteristics.....	13	9.4 Trademarks.....	75
6 Detailed Description	18	9.5 Electrostatic Discharge Caution.....	75
6.1 Overview.....	18	9.6 Glossary.....	75
6.2 Functional Block Diagram.....	18	10 Revision History	76
6.3 Feature Description.....	19	11 Mechanical, Packaging, and Orderable Information	77
6.4 Device Functional Modes.....	27		
6.5 Programming.....	35		
7 Register Maps	43		

4 Pin Configuration and Functions

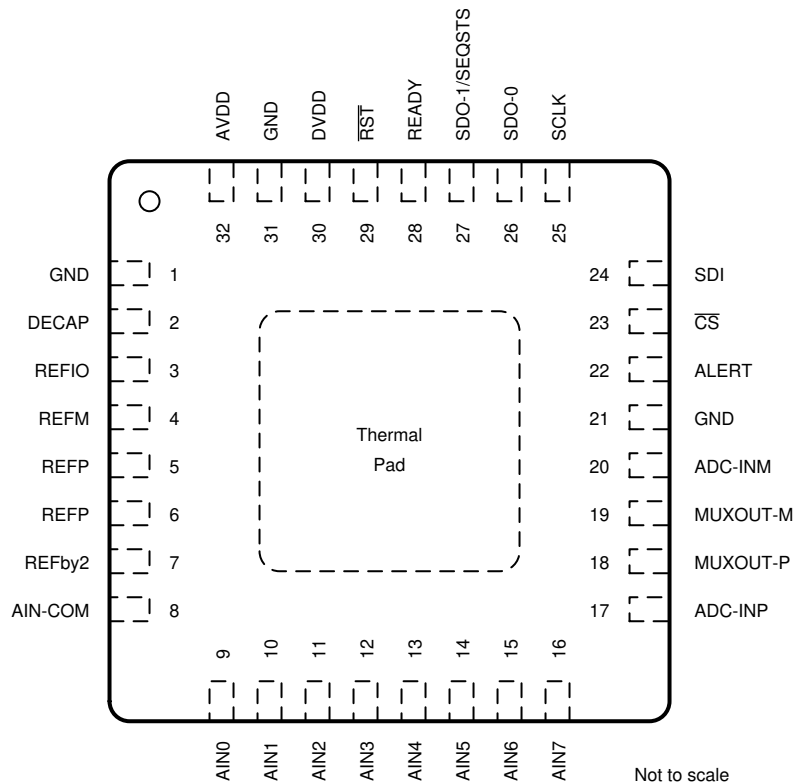

Figure 4-1. RHB Package, 32-Pin VQFN (Top View)

Table 4-1. Pin Functions

PIN		FUNCTION	DESCRIPTION
NAME	NO.		
ADC-INM	20	Analog input	Negative ADC analog input.
ADC-INP	17	Analog input	Positive ADC analog input.
AIN0	9	Analog input	Analog input channel 0.
AIN1	10	Analog input	Analog input channel 1.
AIN2	11	Analog input	Analog input channel 2.
AIN3	12	Analog input	Analog input channel 3.
AIN4	13	Analog input	Analog input channel 4.
AIN5	14	Analog input	Analog input channel 5.
AIN6	15	Analog input	Analog input channel 6.
AIN7	16	Analog input	Analog input channel 7.
AIN-COM	8	Analog input	Common analog input.
ALERT	22	Digital output	Digital ALERT output; active high. This pin is the output of the logical OR of the enabled channel ALERTs.
AVDD	32	Power supply	Analog power-supply pin. Connect a 1µF capacitor from this pin to GND.
\overline{CS}	23	Digital input	Chip-select input pin; active low. The device starts converting the active input channel on the rising edge of \overline{CS} . The device takes control of the data bus when \overline{CS} is low. The SDO-x pins go Hi-Z when \overline{CS} is high.
DECAP	2	Power supply	Connect a 1µF capacitor to GND for the internal power supply.
DVDD	30	Power supply	Interface power-supply pin. Connect a 1µF capacitor from this pin to GND.
GND	1, 21, 31	Power supply	Ground.

Table 4-1. Pin Functions (continued)

PIN		FUNCTION	DESCRIPTION
NAME	NO.		
MUXOUT-M	19	Analog output	MUX negative analog output.
MUXOUT-P	18	Analog output	MUX positive analog output.
READY	28	Digital output	Multifunction output pin. When \overline{CS} is held high, READY reflects the device conversion status. READY is low when a conversion is in process. When \overline{CS} is low, the status of READY depends on the output protocol selection.
REFby2	7	Analog output	The output voltage on this pin is equal to half the voltage on the REFP pin. Connect a 1 μ F capacitor from this pin to GND.
REFIO	3	Analog input/output	External reference voltage input; internal reference is a 4.096V output. Connect a 1 μ F capacitor from this pin to GND.
REFM	4	Analog input	Reference ground potential; short this pin to GND externally.
REFP	5, 6	Analog input/output	Reference buffer output, ADC reference input. Short pins 5 and 6 together.
\overline{RST}	29	Digital input	Asynchronous reset input pin. A low pulse on the \overline{RST} pin resets the device. All register bits return to the default states.
SCLK	25	Digital input	Clock input pin for the serial interface. All system-synchronous data transfer protocols are timed with respect to the SCLK signal.
SDI	24	Digital input	Serial data input pin. This pin transfers data or commands into the device.
SDO-0	26	Digital output	Serial communication pin: data output 0.
SDO-1/ SEQSTS	27	Digital output	Multifunction output pin. By default, this pin indicates the channel scanning status in the auto and custom channel sequence modes. In dual SDO data transfer mode, this pin functions as a serial communication pin: data output 1.
Thermal pad		Supply	Exposed thermal pad; connect to GND.

5 Specifications

5.1 Absolute Maximum Ratings

over operating ambient temperature range (unless otherwise noted)⁽¹⁾

	MIN	MAX	UNIT
AVDD to GND	-0.3	7	V
DVDD to GND	-0.3	7	V
AINx ⁽²⁾ , AIN-COM, MUXOUT-P, MUXOUT-M, ADC-INP, ADC-INM	GND - 0.3	AVDD + 0.3	V
REFP	REFM - 0.3	AVDD + 0.3	V
REFIO	REFM - 0.3	AVDD + 0.3	V
REFM	GND - 0.1	GND + 0.1	V
Digital input pins	GND - 0.3	DVDD + 0.3	V
Digital output pins	GND - 0.3	DVDD + 0.3	V
Input current to any pin except supply pins	-10	10	mA
Junction temperature, T _J	-40	125	°C
Storage temperature, T _{stg}	-65	150	°C

- (1) Stresses beyond those listed under *Absolute Maximum Rating* may cause permanent damage to the device. These are stress ratings only, which do not imply functional operation of the device at these or any other conditions beyond those indicated under *Recommended Operating Condition*. Exposure to absolute-maximum-rated conditions for extended periods may affect device reliability.
- (2) AINx refers to AIN0, AIN1, AIN2, AIN3, AIN4, AIN5, AIN6, and AIN7 pins.

5.2 ESD Ratings

		VALUE	UNIT
V _(ESD)	Electrostatic discharge	Human body model (HBM), per ANSI/ESDA/ JEDEC JS-001, all pins ⁽¹⁾	V
		Charged device model (CDM), per JEDEC specification JESD22-C101, all pins ⁽²⁾	

- (1) JEDEC document JEP155 states that 500V HBM allows safe manufacturing with a standard ESD control process.
- (2) JEDEC document JEP157 states that 250V CDM allows safe manufacturing with a standard ESD control process.

5.3 Thermal Information

THERMAL METRIC ⁽¹⁾		ADS816x	UNIT
		RHB (VQFN)	
		32 PINS	
R _{θJA}	Junction-to-ambient thermal resistance	29.5	°C/W
R _{θJC(top)}	Junction-to-case (top) thermal resistance	18.6	°C/W
R _{θJB}	Junction-to-board thermal resistance	10.2	°C/W
Ψ _{JT}	Junction-to-top characterization parameter	0.2	°C/W
Ψ _{JB}	Junction-to-board characterization parameter	10.2	°C/W
R _{θJC(bot)}	Junction-to-case (bottom) thermal resistance	1.3	°C/W

- (1) For more information about traditional and new thermal metrics, see the [Semiconductor and IC Package Thermal Metrics](#) application note.

5.4 Recommended Operating Conditions

over operating free-air temperature range (unless otherwise noted)

PARAMETER		TEST CONDITIONS	MIN	TYP	MAX	UNIT
POWER SUPPLY						
AVDD	Internal reference		4.5	5	5.5	V
	External reference		3	5	5.5	
DVDD	Operating		1.65	3	5.5	V
	Specified throughput		2.35	3	5.5	
ANALOG INPUTS (Single-Ended Configuration)						
FSR	Full-scale input range		0		V_{REF}	V
V_{IN}	Absolute input voltage	$AINx^{(1)}$ to REFM and $CHx_CHy_CFG^{(2)} = 00b$	-0.1		$V_{REF} + 0.1$	V
		$AINy^{(3)}$ to REFM and $CHx_CHy_CFG = 01b$	-0.1		0.1	
		AIN-COM	-0.1		0.1	
ANALOG INPUTS (Pseudo-Differential Configuration)						
FSR	Full-scale input range		$-V_{REF} / 2$		$V_{REF} / 2$	V
V_{IN}	Absolute input voltage	$AINx$ to REFM and $CHx_CHy_CFG = 00b$	-0.1		$V_{REF} + 0.1$	V
		$AINy$ to REFM and $CHx_CHy_CFG = 10b$	$V_{REF} / 2 - 0.1$		$V_{REF} / 2 + 0.1$	
		AIN-COM	$V_{REF} / 2 - 0.1$		$V_{REF} / 2 + 0.1$	
EXTERNAL REFERENCE INPUT						
V_{REFIO}	REFIO input voltage	REFIO configured as input pin	2.5		$AVDD - 0.3$	V
TEMPERATURE RANGE						
T_A	Ambient temperature		-40	25	125	°C

- (1) $AINx$ refers to analog inputs $AIN0$, $AIN1$, $AIN2$, $AIN3$, $AIN4$, $AIN5$, $AIN6$, and $AIN7$.
- (2) CHx_CHy_CFG bits set the analog input configuration as single-ended or pseudo-differential pair. See the [AIN_CFG](#) register for more details.
- (3) $AINy$ refers to analog inputs $AIN1$, $AIN3$, $AIN5$, and $AIN7$ when $CHx_CHy_CFG = 01b$ or $10b$. See the [Multiplexer Configurations](#) section for more details.

5.5 Electrical Characteristics

at AVDD = 5V, DVDD = 1.65V to 5.5V, REFIO configured as output pin, and maximum throughput (unless otherwise noted); minimum and maximum values at T_A = –40°C to +125°C; typical values at T_A = 25°C

PARAMETER		TEST CONDITIONS	MIN	TYP	MAX	UNIT
ANALOG INPUTS						
C _{SH}	ADC Input capacitance			60		pF
C _{INMUX}	MUX Input capacitance			13		pF
I _{LMUX_ON}	MUX input on-channel leakage current	REFM < V _{IN} < REFP	–750	±10	750	nA
DC PERFORMANCE						
	Resolution			16		Bits
NMC	No missing codes		16			
INL	Integral nonlinearity		–0.8	±0.35	0.8	LSB
DNL	Differential nonlinearity		–0.5	±0.2	0.5	LSB
V _{OS}	Input offset error		–10	±0.5	10	LSB
	Input offset error match		–1	±0.5	1	LSB
dV _{OS} /dT	Input offset thermal drift			0.25		µV/°C
G _E	Gain error	Referred to REFIO	–0.06	±0.002	0.06	%FSR
	Gain error match	Referred to REFIO	–0.005	±0.0025	0.005	%FSR
dG _E /dT	Gain error thermal drift	Referred to REFIO		±1		ppm/°C
TNS	Transition noise	V _{IN} = V _{REF} / 2		0.6		LSB
AC PERFORMANCE						
SINAD	Signal-to-noise + distortion	f _{IN} = 2kHz	91.6	93.5		dB
SNR	Signal-to-noise-ratio	f _{IN} = 2kHz	91.8	93.6		dB
THD	Total harmonic distortion	f _{IN} = 2kHz		–110		dB
SFDR	Spurious-free dynamic range	f _{IN} = 2kHz		112		dB
	Isolation crosstalk	f _{IN} = 100kHz		–115		dB
REFERENCE BUFFER						
V _{RO}	Reference buffer offset voltage	V _{RO} = V _{REFP} – V _{REFIO} , T _A = 25°C	–250		250	µV
C _{REFP}	Decoupling capacitor on REFP			22		µF
R _{ESR}	External series resistance		0		1.3	Ω
REFby2 BUFFER						
V _{REFby2}	REFby2 output voltage			V _{REFP} / 2		V
I _{REFby2}	DC sourcing current from REFby2				2	mA
C _{REFby2}	Decoupling capacitor on REFby2		1			µF
INTERNAL REFERENCE OUTPUT						
V _{REFIO}	REFIO output voltage ⁽¹⁾	T _A = 25°C, REFIO configured as output pin	4.091	4.096	4.101	V
dV _{REFIO} /dT	Internal reference temperature drift			4	18	ppm/°C
C _{REFIO}	Decoupling capacitor on REFIO	REFIO configured as output	1			µF
EXTERNAL REFERENCE INPUT						
I _{REFIO}	REFIO input current	REFIO configured as input pin		0.1	1	µA
C _{REF}	Internal capacitance on REFIO pin	REFIO configured as input pin		10		pF
SAMPLING DYNAMICS						

5.5 Electrical Characteristics (continued)

at AVDD = 5V, DVDD = 1.65V to 5.5V, REFIO configured as output pin, and maximum throughput (unless otherwise noted); minimum and maximum values at T_A = -40°C to +125°C; typical values at T_A = 25°C

PARAMETER		TEST CONDITIONS	MIN	TYP	MAX	UNIT
	Aperture delay			4		ns
t _{j-RMS}	Aperture jitter			2		ps RMS
f _{-3dB(small)}	Small-signal bandwidth	Measured at ADC inputs		23		MHz
POWER- SUPPLY CURRENTS						
I _{AVDD}	Analog supply current	ADS8168, AVDD = 5V		5.3	6.4	mA
		ADS8167, AVDD = 5V		3.9	5	
		ADS8166, AVDD = 5V		3	4.1	
		Static, no conversion		2.3		
		Static, PD_REFBUF = 1		1.6		μA
		Static, PD_REF = 1		800		
		Static, PD_REFBUF, PD_REF and PD_REFby2 = 1		180		
I _{DVDD}	Digital supply current	DVDD = 3V, C _{LOAD} = 10pF, no conversion		0.45		μA

(1) Does not include the variation in voltage resulting from solder effects.

5.6 Timing Requirements

at AVDD = 5V, DVDD = 1.65V to 5.5V, and maximum throughput (unless otherwise noted); minimum and maximum values at $T_A = -40^{\circ}\text{C}$ to $+125^{\circ}\text{C}$; typical values at $T_A = 25^{\circ}\text{C}$

			MIN	NOM	MAX	UNIT
CONVERSION CYCLE						
f_{CYCLE}	Sampling frequency	ADS8168			1000	kHz
		ADS8167			500	
		ADS8166			250	
t_{CYCLE}	ADC cycle-time period	ADS8168	1			μs
		ADS8167	2			
		ADS8166	4			
$t_{\text{wh_CSZ}}$	Pulse duration: $\overline{\text{CS}}$ high	SDI contains command for register read or write	200			ns
		no register read or write operation	30			
$t_{\text{wl_CSZ}}$	Pulse duration: $\overline{\text{CS}}$ low		30			ns
t_{ACQ}	Acquisition time		300			ns
$t_{\text{qL_ACQ}}$	Quiet acquisition time		30			ns
$t_{\text{d_CNVCAP}}$	Quiet aperture time		20			ns
ASYNCHRONOUS RESET AND LOW POWER MODES						
$t_{\text{wl_RST}}$	Pulse duration: $\overline{\text{RST}}$ low		100			ns
SPI-COMPATIBLE SERIAL INTERFACE						
f_{CLK}	Serial clock frequency	$2.35 \leq \text{DVDD} \leq 5.5\text{V}$, $V_{\text{IH}} > 0.7 \text{ DVDD}$, $V_{\text{IL}} < 0.3 \text{ DVDD}$			50	MHz
		$1.65\text{V} \leq \text{DVDD} < 2.35\text{V}$, $V_{\text{IH}} \geq 0.8 \text{ DVDD}$, $V_{\text{IL}} \leq 0.2 \text{ DVDD}$			20	
		$1.65\text{V} \leq \text{DVDD} < 2.35\text{V}$, $V_{\text{IH}} \geq 0.9 \text{ DVDD}$, $V_{\text{IL}} \leq 0.1 \text{ DVDD}$			50	
t_{CLK}	Serial clock time period		$1 / f_{\text{CLK}}$			ns
$t_{\text{ph_CK}}$	SCLK high time		0.45		0.55	t_{CLK}
$t_{\text{pl_CK}}$	SCLK low time		0.45		0.55	t_{CLK}
$t_{\text{su_CSCK}}$	Setup time: $\overline{\text{CS}}$ falling to the first SCLK capture edge		15			ns
$t_{\text{su_CKDI}}$	Setup time: SDI data valid to the SCLK capture edge		3			ns
$t_{\text{ht_CKDI}}$	Hold time: SCLK capture edge to (previous) data valid on SDI		4			ns
$t_{\text{ht_CKCS}}$	Delay time: last SCLK falling to $\overline{\text{CS}}$ rising		7.5			ns
SOURCE-SYNCHRONOUS SERIAL INTERFACE						
f_{CLK}	Serial clock frequency	$2.35\text{V} \leq \text{DVDD} \leq 5.5\text{V}$, SDR (DATA_RATE = 0b)			70	MHz
		$2.35\text{V} \leq \text{DVDD} \leq 5.5\text{V}$, DDR (DATA_RATE = 1b)			35	
t_{CLK}	Serial clock time period		$1 / f_{\text{CLK}}$			ns

5.7 Switching Characteristics

at AVDD = 5V, DVDD = 1.65V to 5.5V, and maximum throughput (unless otherwise noted); minimum and maximum values at T_A = -40°C to +125°C; typical values at T_A = 25°C

PARAMETER	TEST CONDITIONS	MIN	TYP	MAX	UNIT
CONVERSION CYCLE					
t _{CONV}	Conversion time	ADS8168		660	ns
		ADS8167		1200	
		ADS8166		2500	
ASYNCHRONOUS RESET, AND LOW POWER MODES					
t _{d_RST}	Delay time: RST rising to READY rising			4	ms
t _{PU_ADC}	Power-up time for converter module	Change PD_ADC = 1b to 0b	1		ms
t _{PU_REFIO}	Power-up time for internal reference	Change PD_REF = 1b to 0b	5		ms
t _{PU_REFBUF}	Power-up time for internal reference buffer	Change PD_REFBUF = 1b to 0b	10		ms
t _{PU_Device}	Power-up time for device		10		ms
SPI-COMPATIBLE SERIAL INTERFACE					
t _{den_CSDO}	Delay time: CS falling to data enable			15	ns
t _{dz_CSDO}	Delay time: CS rising to SDO going to Hi-Z			15	ns
t _{d_CKDO}	Delay time: SCLK launch edge to (next) data valid on SDO			19	ns
t _{ht_CKDO}	Hold time: SCLK launch edge to (previous) data valid on SDO		2.5		ns
t _{d_CSRDY_t}	Delay time: CS falling to READY falling			15	ns
SOURCE-SYNCHRONOUS SERIAL INTERFACE (External Clock)					
t _{d_CKSTR_r}	Delay time: SCLK launch edge to READY rising			23	ns
t _{d_CKSTR_f}	Delay time: SCLK launch edge to READY falling			23	ns
t _{off_STRDO_f}	Time offset: READY falling to (next) data valid on SDO		-2	2	ns
t _{off_STRDO_r}	Time offset: READY rising to (next) data valid on SDO		-2	2	ns
t _{ph_STR}	Strobe output high time	2.35V ≤ DVDD ≤ 5.5V	0.45	0.55	t _{STR}
t _{pl_STR}	Strobe output low time	2.35V ≤ DVDD ≤ 5.5V	0.45	0.55	t _{STR}

5.8 Timing Diagrams

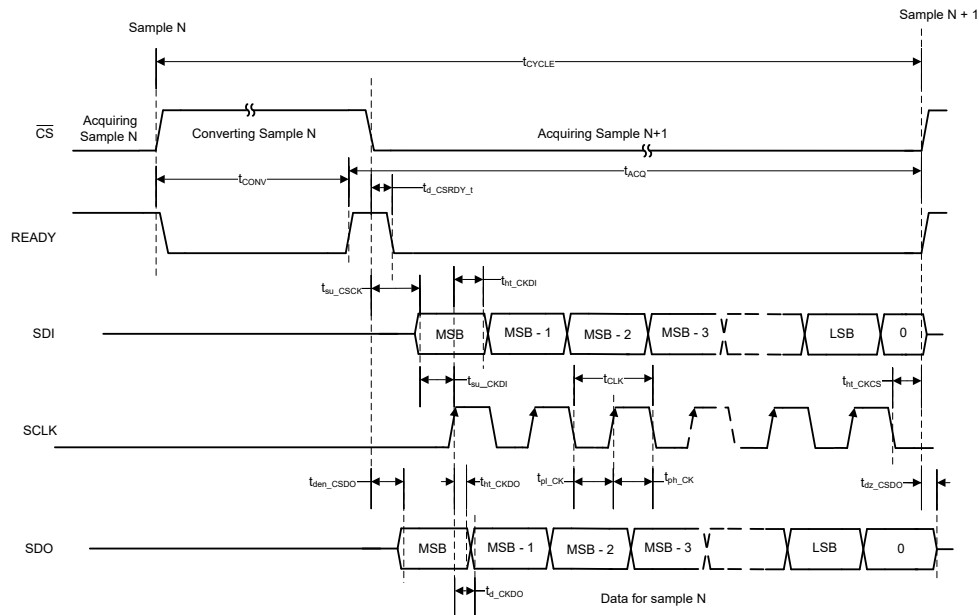

A. The SPI-00 interface mode is illustrated here. For SPI-01, -10, and-11 modes, see the [Enhanced-SPI Interface](#) section.

Figure 5-1. Conversion Cycle Timing: $\overline{\text{CS}} = 1$ Longer Than t_{CONV}

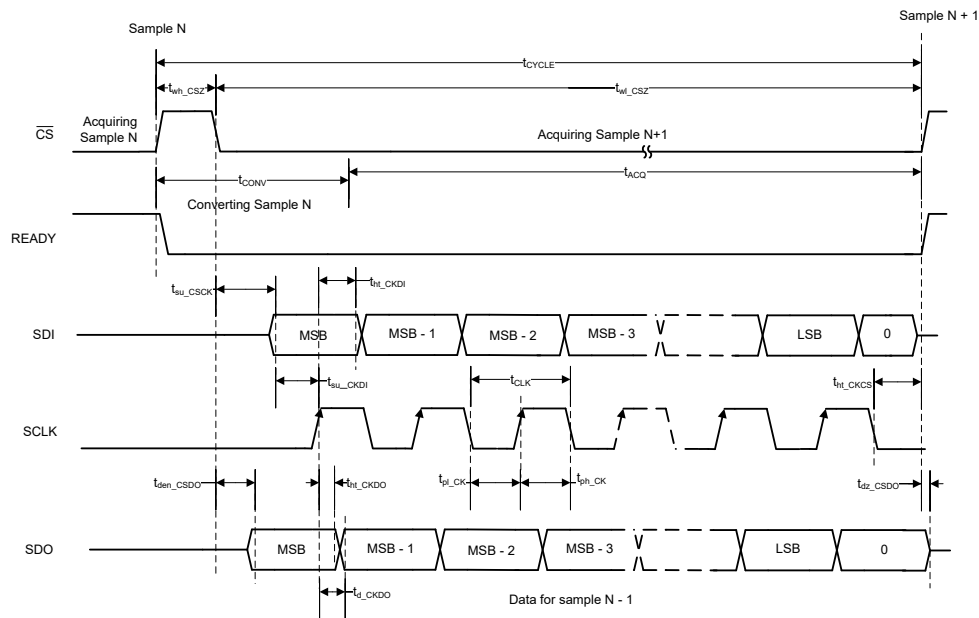

A. The SPI-00 interface mode is illustrated here. For SPI-01, -10, and-11 modes, see the [Enhanced-SPI Interface](#) section.

Figure 5-2. Conversion Cycle Timing: $\overline{\text{CS}} = 1$ Shorter Than t_{CONV}

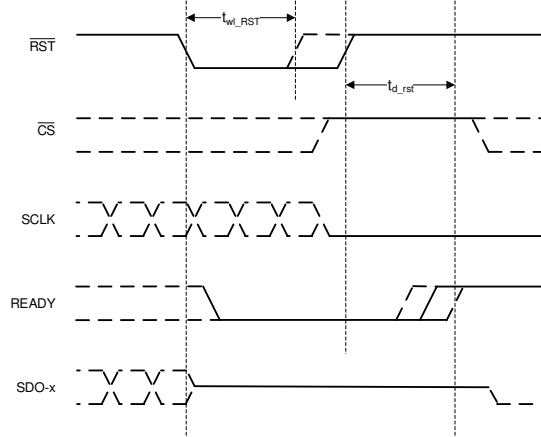

Figure 5-3. Asynchronous Reset Timing

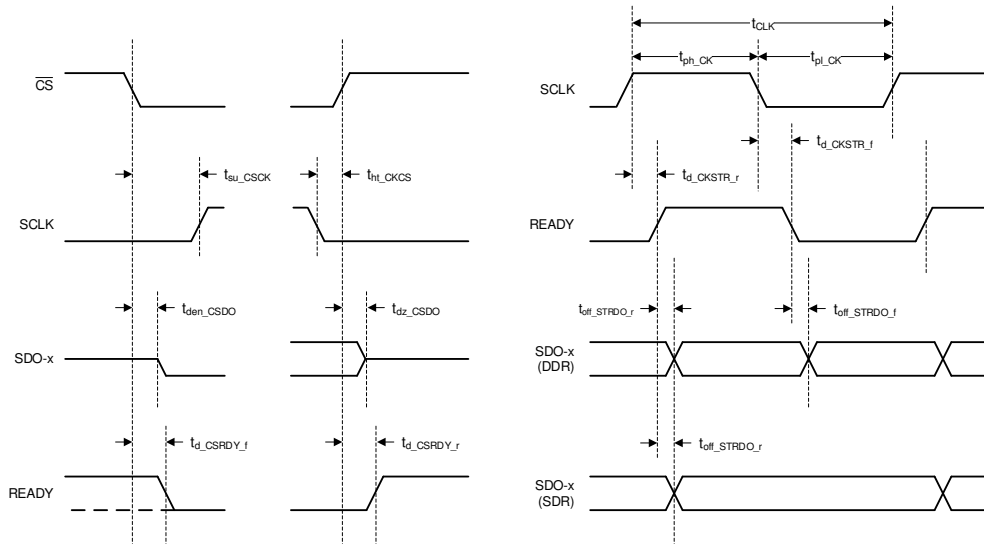
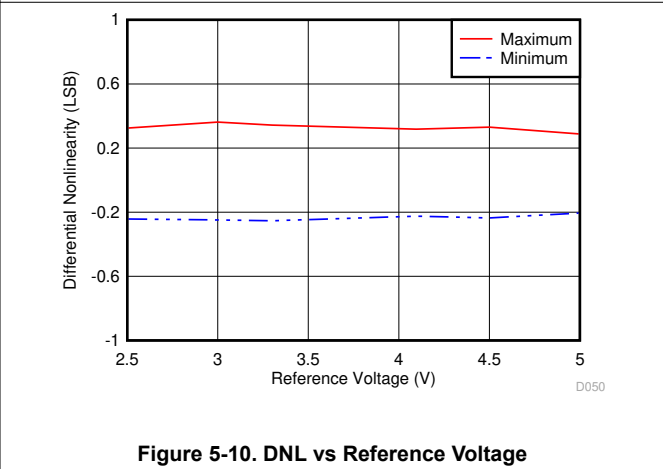
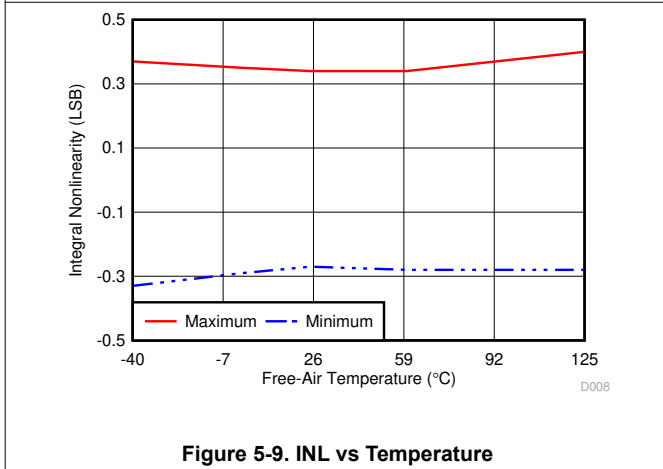
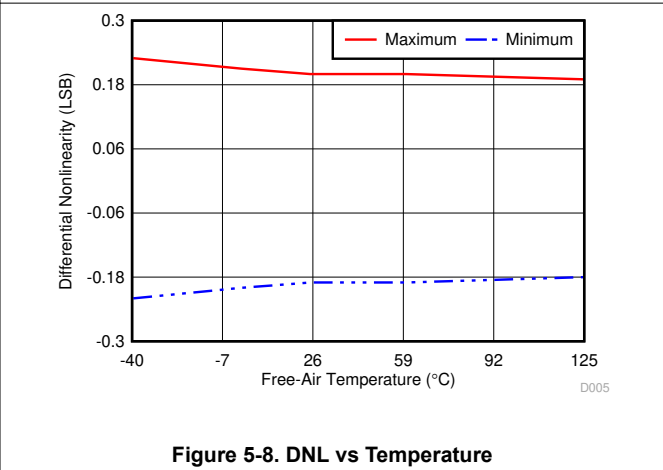
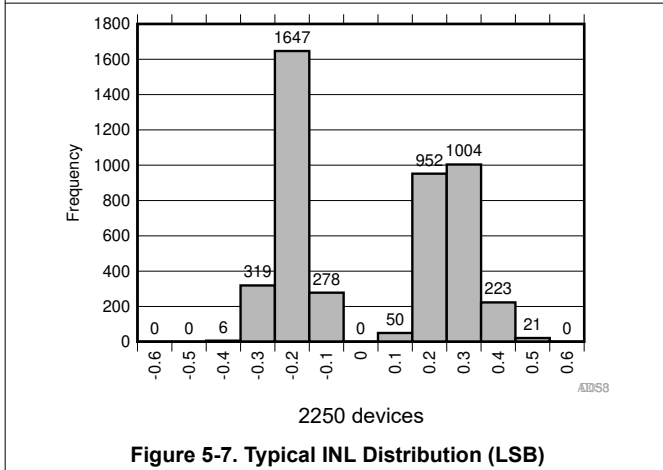
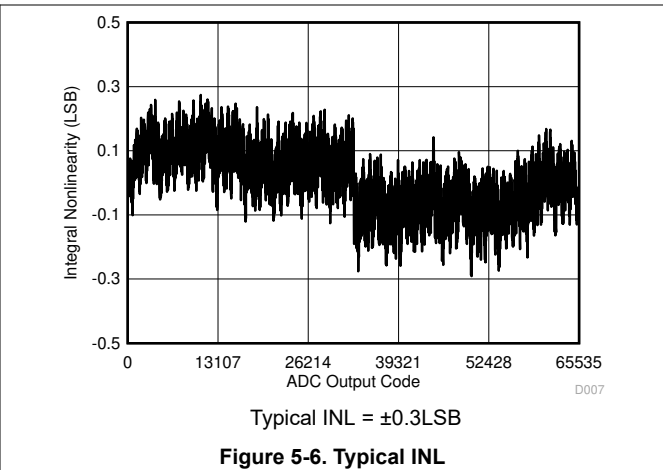
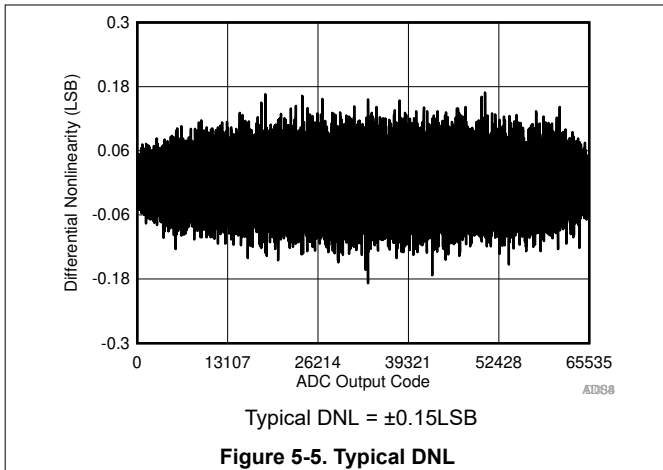

Figure 5-4. Clock Re-Timer Serial Interface Timing

5.9 Typical Characteristics

at AVDD = 5V, DVDD = 1.65V to 5.5V, REFIO configured as output pin, and maximum throughput (unless otherwise noted)



5.9 Typical Characteristics (continued)

at AVDD = 5V, DVDD = 1.65V to 5.5V, REFIO configured as output pin, and maximum throughput (unless otherwise noted)

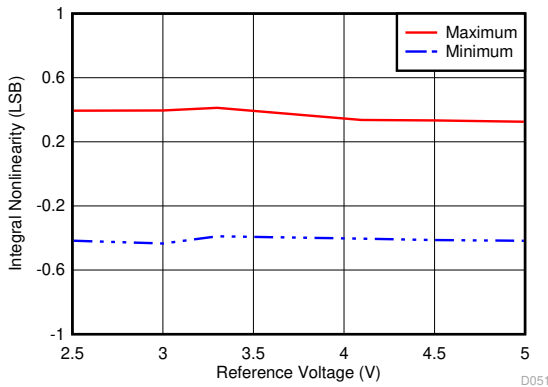
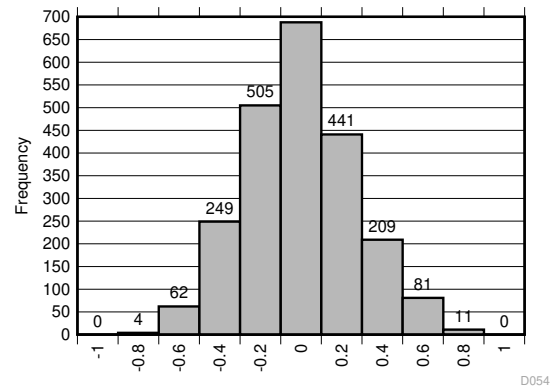
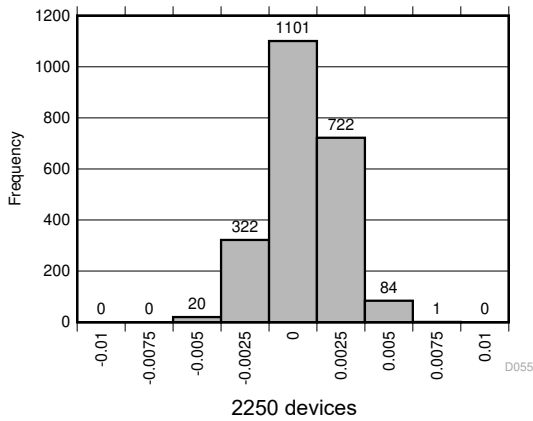

Figure 5-11. INL vs Reference Voltage



2250 devices

Figure 5-12. Typical Offset Distribution (LSB)



2250 devices

Figure 5-13. Typical Gain Error Distribution (%FSR)

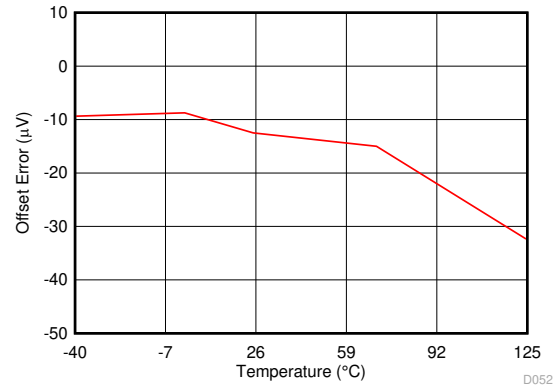

REF_SEL[2:0] = 000b

Figure 5-14. Offset Error vs Temperature

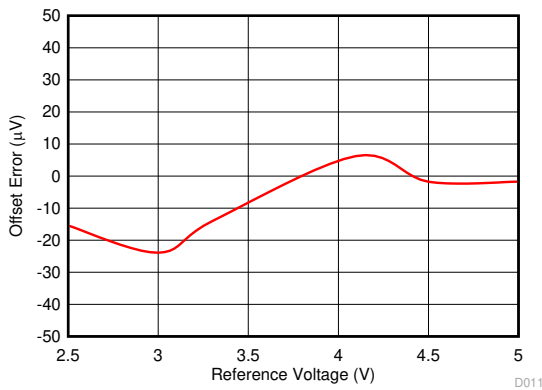

With the appropriate REF_SEL[2:0]; see the [OFST_CAL](#) register

Figure 5-15. Offset Error vs Reference Voltage

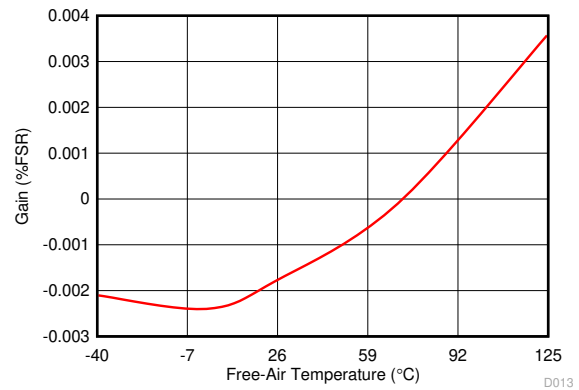

EN_MARG = 0b

Figure 5-16. Gain Error (ADC + REFBUF) vs Temperature

5.9 Typical Characteristics (continued)

at AVDD = 5V, DVDD = 1.65V to 5.5V, REFIO configured as output pin, and maximum throughput (unless otherwise noted)

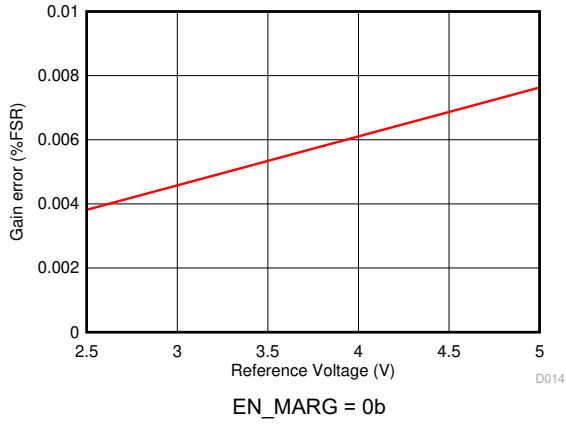

Figure 5-17. Gain Error (ADC + REFBUF) vs Reference Voltage

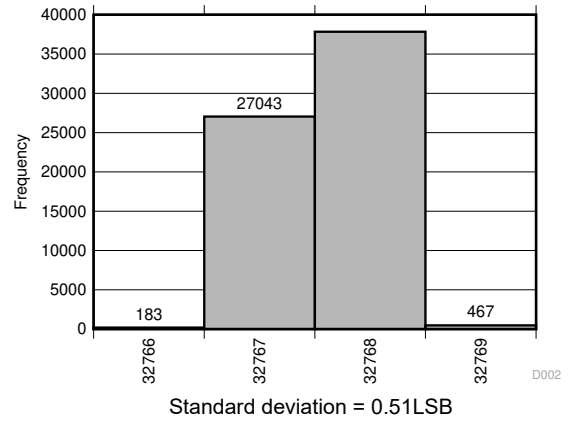

Figure 5-18. DC Input Histogram

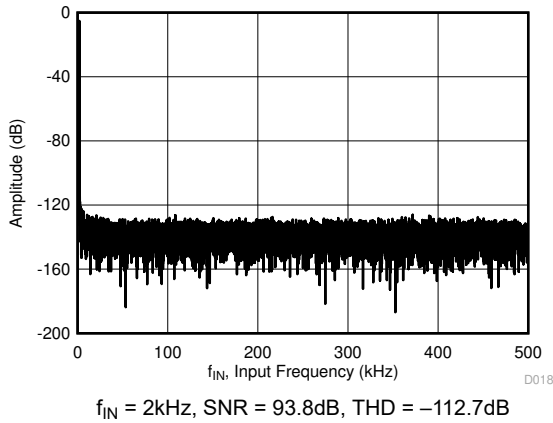

Figure 5-19. Typical FFT, ADS8168

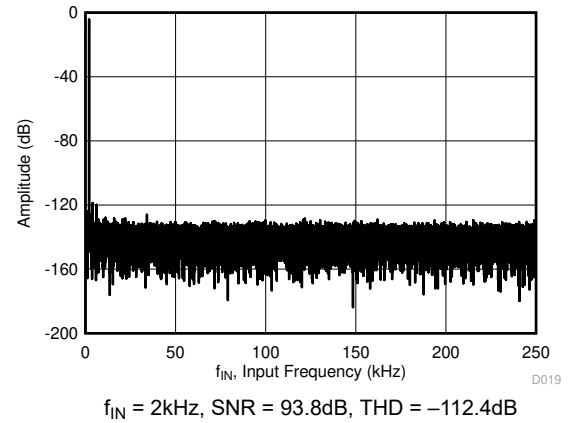

Figure 5-20. Typical FFT, ADS8167

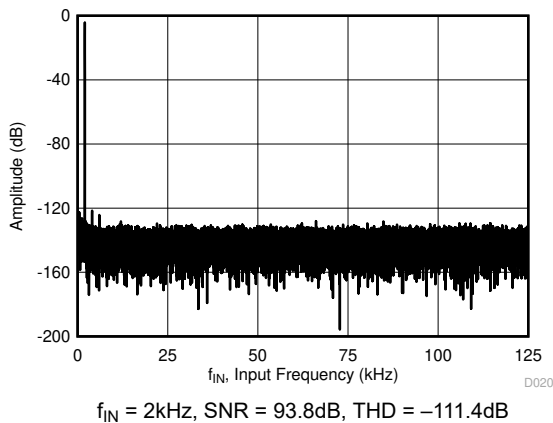

Figure 5-21. Typical FFT, ADS8166

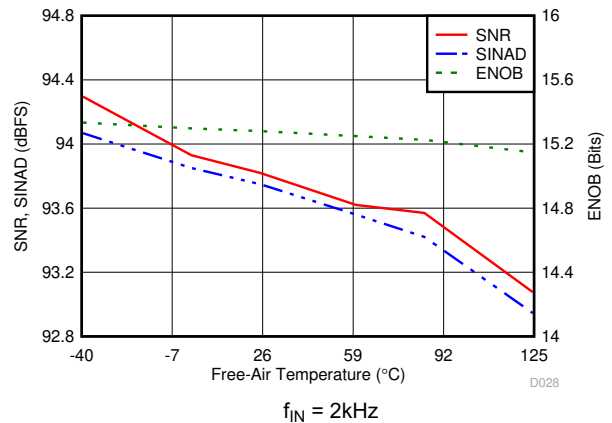

Figure 5-22. Noise Performance vs Temperature

5.9 Typical Characteristics (continued)

at AVDD = 5V, DVDD = 1.65V to 5.5V, REFIO configured as output pin, and maximum throughput (unless otherwise noted)

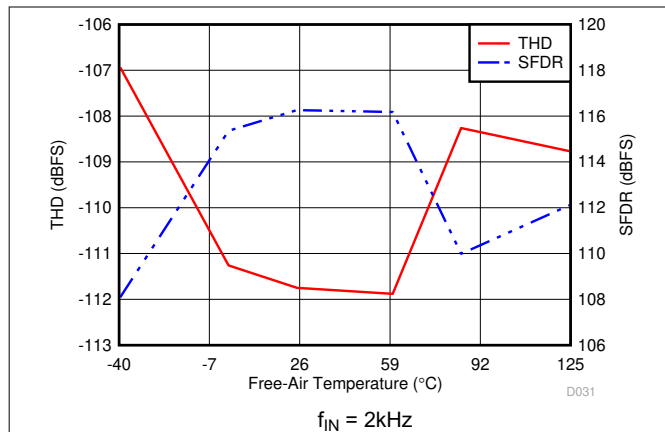

Figure 5-23. Distortion Performance vs Temperature

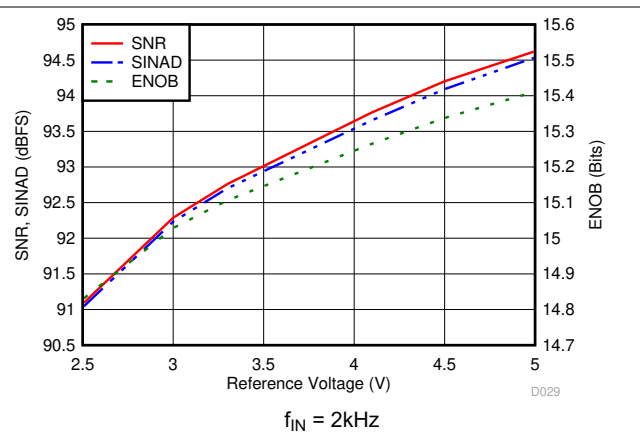

Figure 5-24. Noise Performance vs Reference Voltage

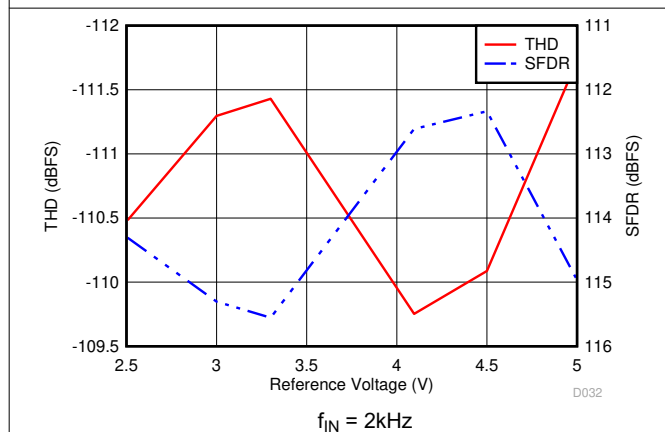

Figure 5-25. Distortion Performance vs Reference Voltage

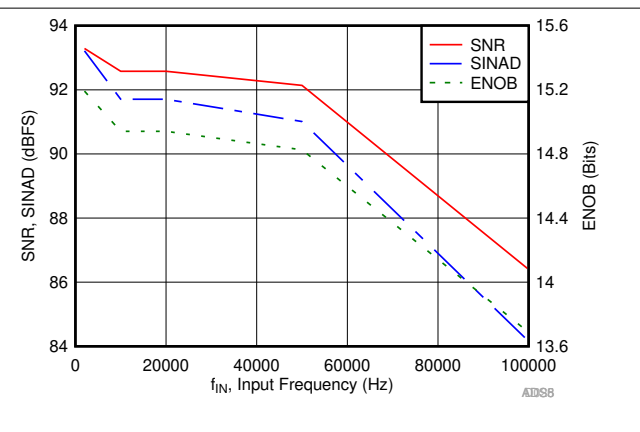

Figure 5-26. Noise Performance vs Input Frequency

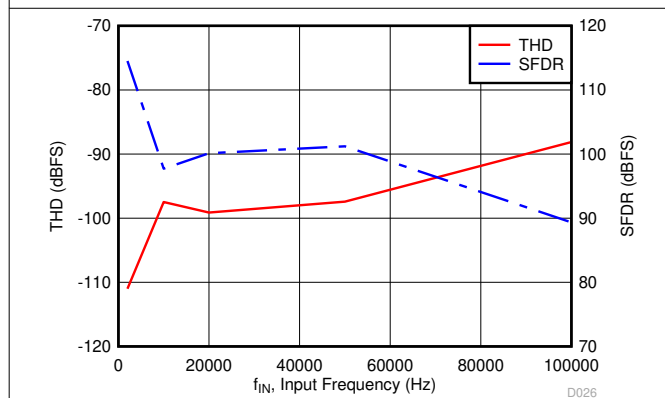

Figure 5-27. Distortion Performance vs Input Frequency

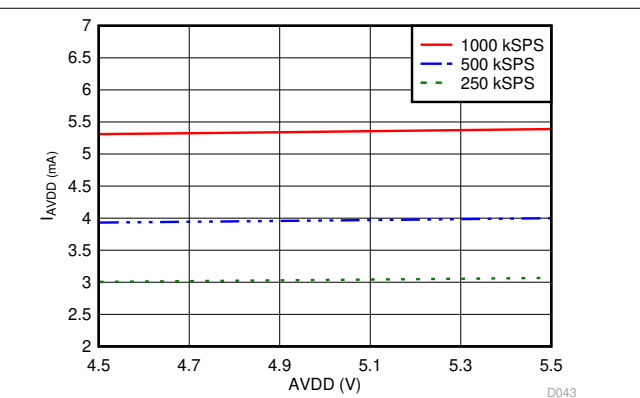
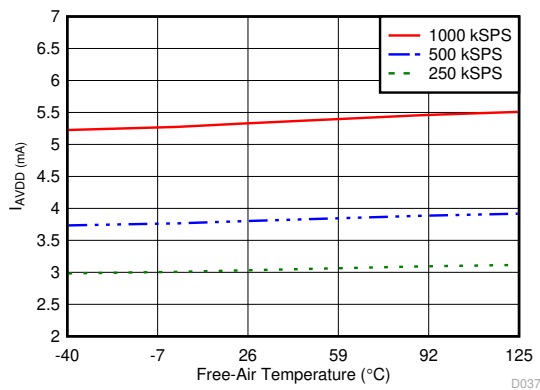

Figure 5-28. Analog Supply Current vs Supply Voltage

5.9 Typical Characteristics (continued)

at AVDD = 5V, DVDD = 1.65V to 5.5V, REFIO configured as output pin, and maximum throughput (unless otherwise noted)



AVDD = 5V
Figure 5-29. Analog Supply Current vs Temperature

6 Detailed Description

6.1 Overview

The ADS816x is a 16-bit successive approximation register (SAR) analog-to-digital converter (ADC) with an analog multiplexer. This device integrates a reference, reference buffer, REFby2 buffer, low-dropout regulator (LDO), and features high performance at full throughput and low power consumption.

The ADS816x supports unipolar, single-ended and pseudo-differential analog input signals. The analog multiplexer is optimized for low distortion and extended settling time. The internal reference generates a low-drift, 4.096V reference output. The integrated reference buffer supports burst mode for data acquisition of external reference voltages in the range 2.5V to 5V. For DC level shifting of the analog input signals, the device has a REFby2 output. The REFby2 output is derived from the output of the integrated reference buffer (the REFP pin).

When a conversion is initiated, the differential input between the ADC-INP and ADC-INM pins is sampled on the internal capacitor array. The device uses an internal clock to perform conversions. During the conversion process, both analog inputs of the ADC are disconnected from the internal circuit. At the end of conversion process, the device reconnects the sampling capacitors to the ADC-INP and ADC-INM pins and enters an acquisition phase.

The integrated LDO allows the device to operate on a single supply, AVDD. The device consumes only 26.5mW, 19.5mW, and 15mW of power when operating at 1MSPS (ADS8168), 500kSPS (ADS8167), and 250kSPS (ADS8166), respectively, with the internal reference, reference buffer, REFby2 buffer, and LDO enabled.

The enhanced-SPI digital interface is backward-compatible with traditional SPI protocols. Configurable features boost analog performance and simplify board layout, timing, firmware, and support full throughput at lower clock speeds. These features enable a variety of microcontrollers, digital signal processors (DSPs), and field-programmable gate arrays (FPGAs) to be used.

The ADS816x enables optical line cards, test and measurement, medical, and industrial applications to achieve fast, low-noise, low-distortion, and low-power data acquisition in a small form-factor.

6.2 Functional Block Diagram

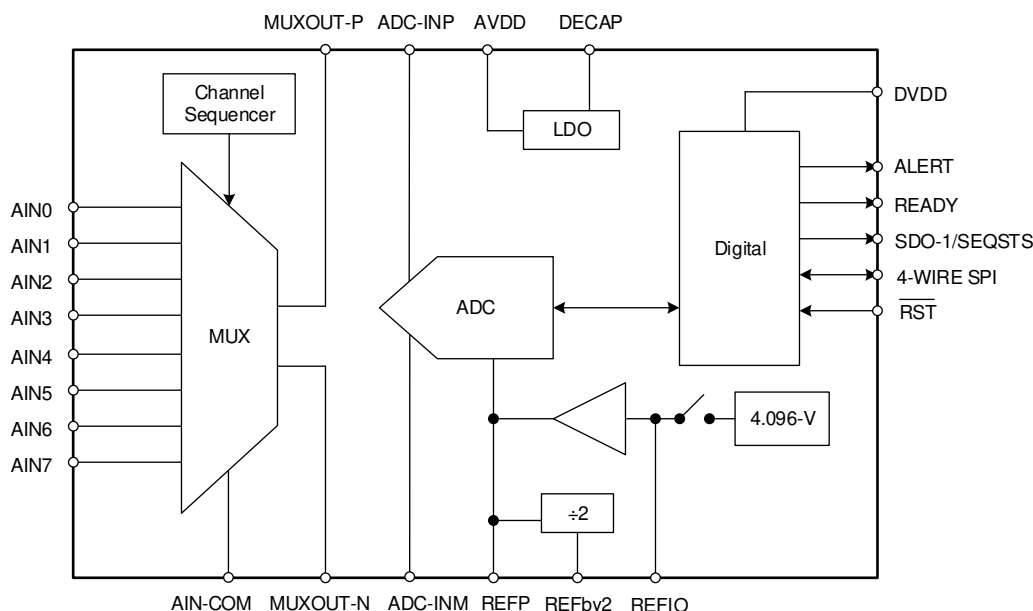

6.3 Feature Description

The ADS816x is comprised of five modules: the converter (SAR ADC), multiplexer (MUX), the reference module, the enhanced-SPI interface, and the low-dropout regulator (LDO). See the [Functional Block Diagram](#) section.

The LDO module is powered by the AVDD supply, and generates the bias voltage for the internal circuit blocks of the device. The reference buffer drives the capacitive switching load present at the reference pins during the conversion process. The multiplexer selects among eight analog input channels as the input for the converter module. The converter module samples and converts the analog input into an equivalent digital output code. The enhanced-SPI interface module facilitates communication and data transfer between the device and the host controller.

6.3.1 Analog Multiplexer

Figure 6-1 shows the small-signal equivalent circuit of the sample-and-hold circuit. Each sampling switch is represented by resistance (R_{S1} and R_{S2} , typically 50Ω) in series with an ideal switch (SW). The sampling capacitors, C_{S1} and C_{S2} , are typically 60pF .

The multiplexer on-resistance (R_{MUX}), is typically a 40Ω resistor in series between the ON channel and the MUXOUT-P or MUXOUT-M pins. The multiplexer analog input typically has a 13pF on-channel capacitance (C_{MUX}).

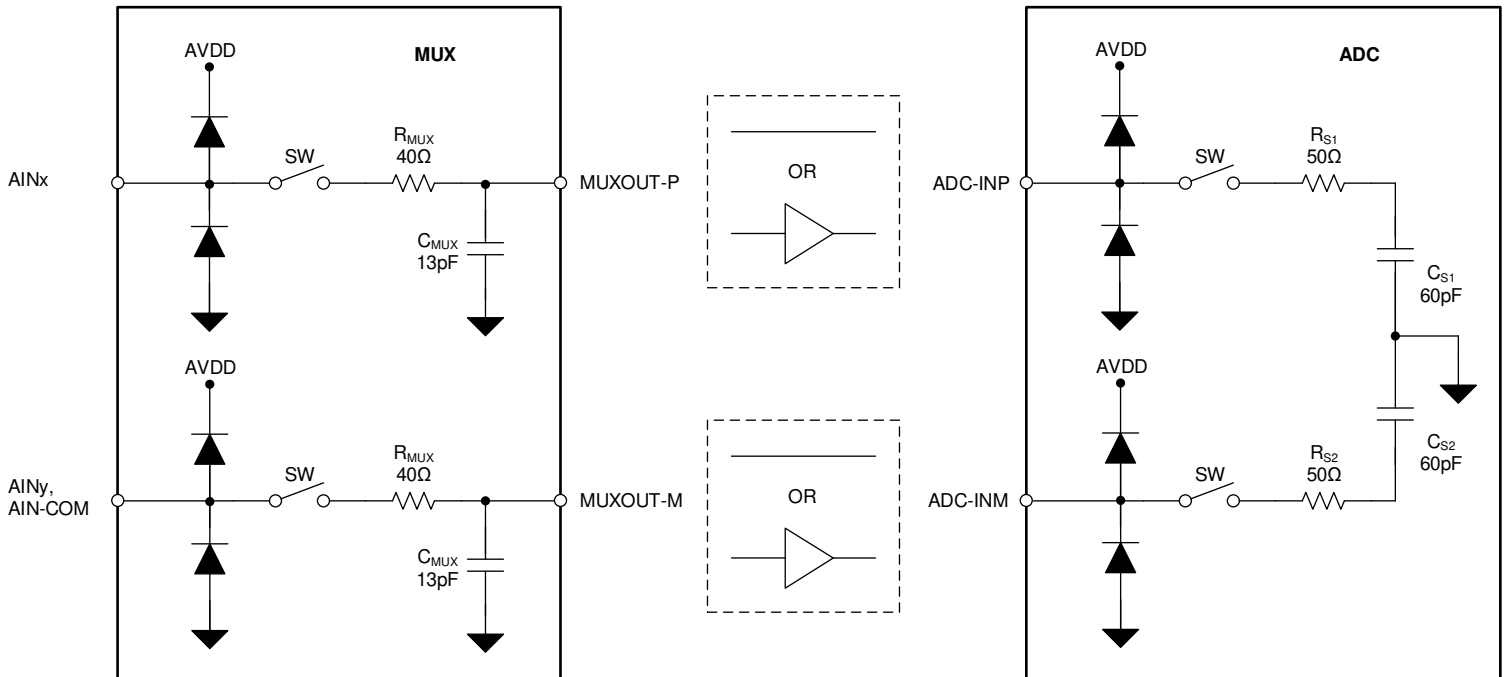

Figure 6-1. Input Sampling Stage Equivalent Circuit

During the input signal acquisition phase, the ADC-INP and ADC-INM inputs are individually sampled on C_{S1} and C_{S2} , respectively. During the conversion process, the device converts for the voltage difference between the two sampled values: $V_{\text{ADC-INP}} - V_{\text{ADC-INM}}$.

Each analog input pin has electrostatic discharge (ESD) protection diodes to AVDD and GND. Keep the analog inputs within the specified range to avoid turning the diodes on.

6.3.1.1 Multiplexer Configurations

The ADS816x supports single-ended and pseudo-differential analog input signals. The flexible analog input channel configuration supports interfacing various types of sensors. Figure 6-2 shows how different configurations for the analog inputs.

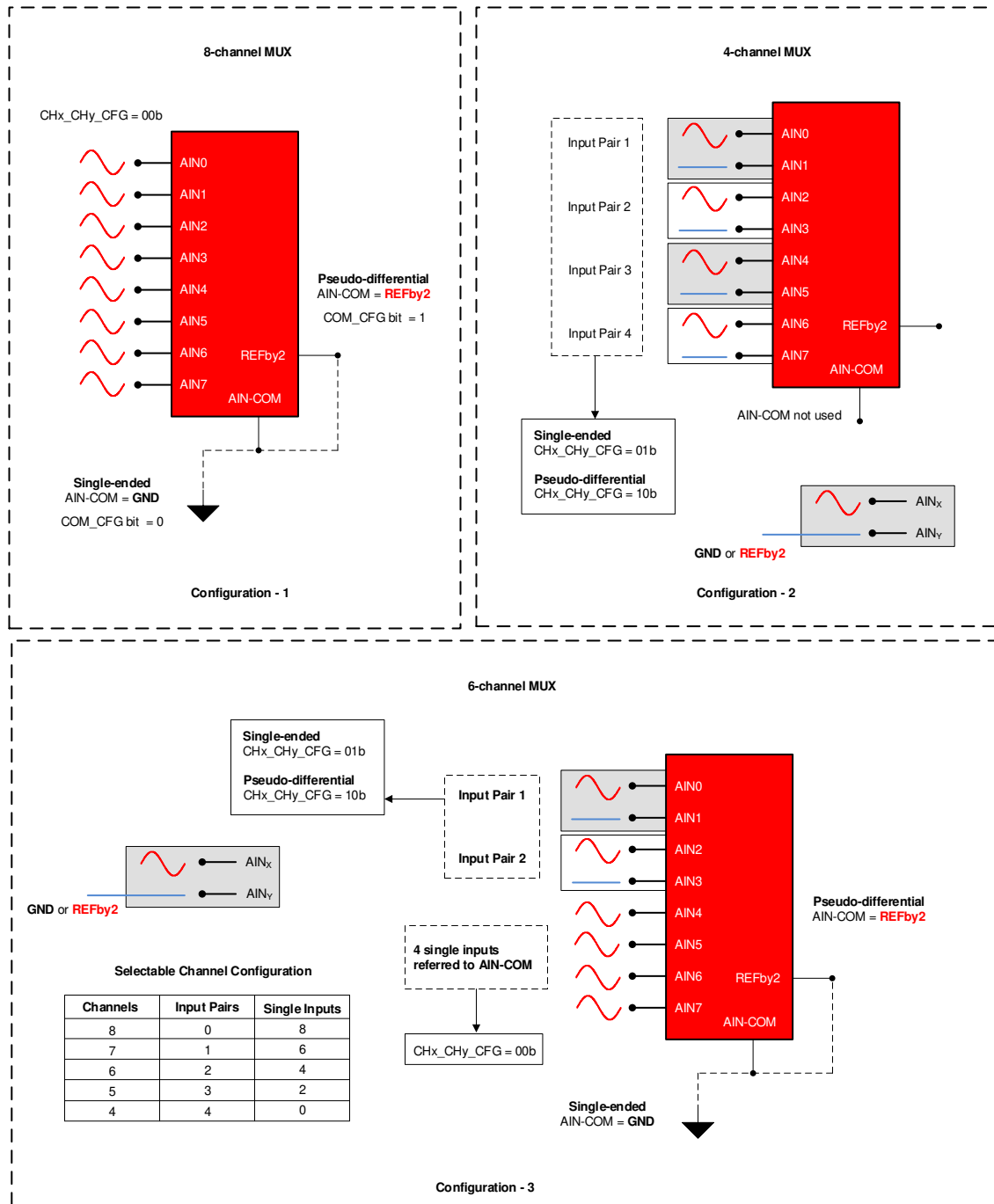

Figure 6-2. Analog Input Configurations

The analog inputs configurations are:

- **Configuration 1:** Eight-channel MUX with the [AIN_CFG](#) register set to 00h. The AIN-COM input range is decided by the [COM_CFG](#) register.
 - Single-ended inputs with the AIN-COM input set to GND (set the [COM_CFG](#) register to 00h).
 - Pseudo-differential inputs with the AIN-COM input set to $V_{REF} / 2$ (set the [COM_CFG](#) register to 01h).
- **Configuration 2:** Four-channel MUX.
 - As shown in [Table 6-1](#), the [AIN_CFG](#) register selects the analog input range of individual pairs.
- **Configuration 3:** Single-ended and pseudo-differential inputs.
 - Among the eight analog inputs of the MUX, some inputs are configured as pairs and some inputs are configured as individual channels. [Table 6-1](#) lists options for channel configuration.
 - For channels configured as pairs, the [AIN_CFG](#) register selects the single-ended or pseudo-differential configuration for individual pairs.
 - For individual channels, the [COM_CFG](#) register decides the single-ended or pseudo-differential configuration.

Table 6-1. Channel Configuration Options

SERIAL NUMBER	TOTAL CHANNELS	INPUT PAIRS ⁽¹⁾ ⁽²⁾	INDIVIDUAL CHANNELS
1	8	0	8
2	7	1	6
3	6	2	4
4	5	3	2
5	4	4	0

(1) Channel pairs are formed as [AIN0 - AIN1], [AIN2 - AIN3], [AIN4 - AIN5], and [AIN6 - AIN7].

(2) When channels are configured as pairs, AIN0, AIN2, AIN4, and AIN6 are positive inputs.

Note

The [COM_CFG](#) register sets the input voltage range of the AIN-COM pin. Connect the AIN-COM pin to GND (set the [COM_CFG](#) register to 0b) or REF_{by2} (set the [COM_CFG](#) register to 1b) externally. When using the MUX in a four-channel configuration, the [COM_CFG](#) register has no effect; connect the AIN-COM pin to GND to avoid noise coupling.

6.3.1.2 Multiplexer With Minimum Crosstalk

For precision measurement in a multichannel system, coupling (such as crosstalk) from one channel to another potentially distorts the measurement. In conventional multiplexers, as shown in Figure 6-3, the off channel parasitic capacitance between the drain and the source of the switch (C_{DSY}) couples the off channel signal to the on channel.

Figure 6-3 shows that the ADS816x uses a T-switch structure. In this switch architecture, the off channel parasitic capacitance is connected to ground, which significantly reduces coupling. Make sure to avoid signal coupling on the printed circuit board (PCB), as described in the *Layout* section.

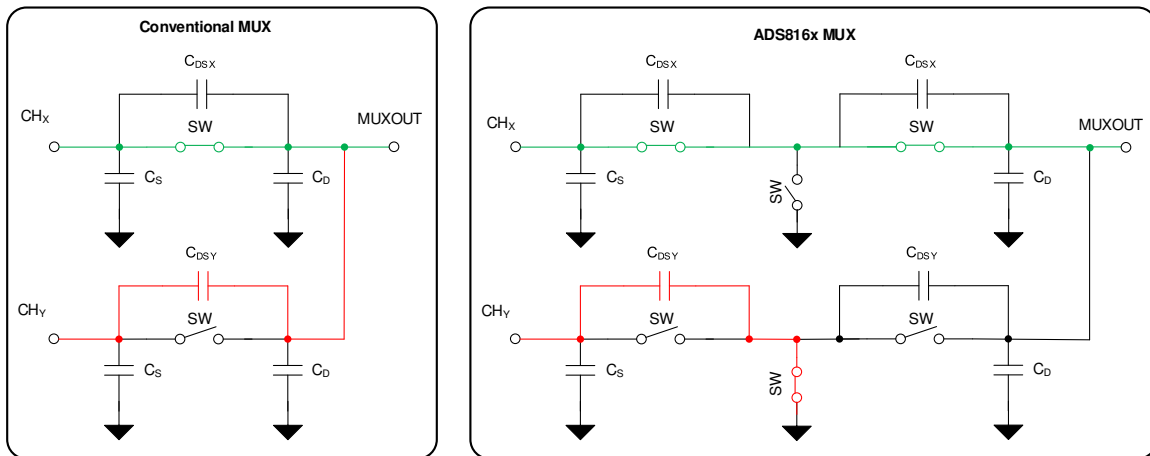

Figure 6-3. Isolation Crosstalk in a Conventional MUX versus the ADS816x

6.3.1.3 Early Switching for Direct Sensor Interface

Figure 6-4 shows the small-signal equivalent model of the ADS816x analog inputs. The multiplexer input has a switch resistance (R_{MUX}) and parasitic capacitance (C_{MUX}). The parasitic capacitance causes a charge kickback on the MUX analog input at the same time as the ADC sampling capacitor causes a charge kickback on ADC inputs.

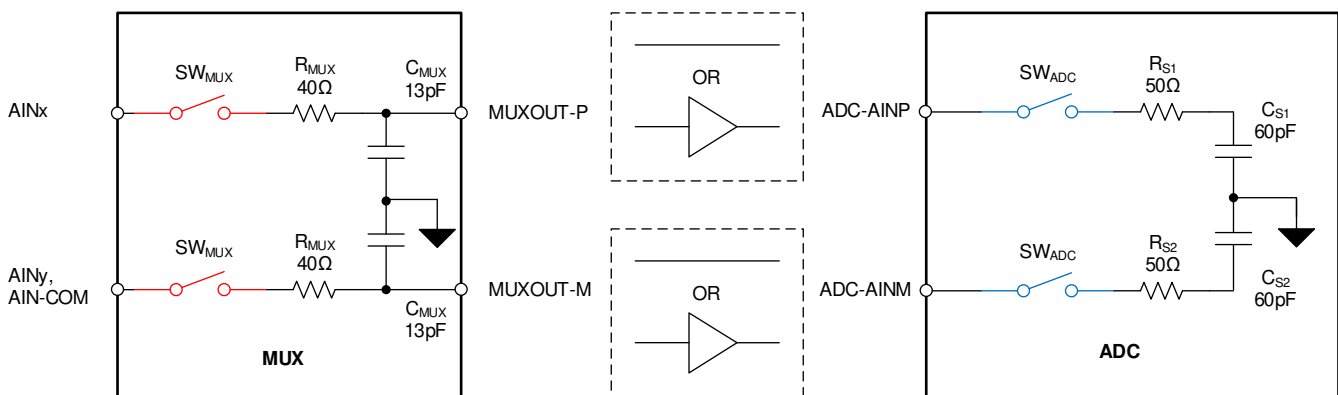

Figure 6-4. Synchronous and Timed Switching of the MUX and ADC Input Switches

In conventional multichannel SAR ADCs, the acquisition time of the ADC is also the settling time available at the analog inputs of the multiplexer because these times are internally connected. Thus, high-bandwidth op amps are required at the analog inputs of the multiplexer to settle the charge kickback. However, multiple high-bandwidth op amps significantly increase power dissipation, cost, and size of the solution.

The analog inputs of the ADS816x provide a long settling time ($t_{\text{CYCLE}} = 100 \text{ ns}$), resulting in long acquisition time at the MUX inputs when using a driver amplifier between the MUX outputs and the ADC inputs. Figure 6-5 shows a timing diagram of this long acquisition phase. The low parasitic capacitance together with the enhanced settling time eliminate the need to use an op amp at the multiplexer input in most applications.

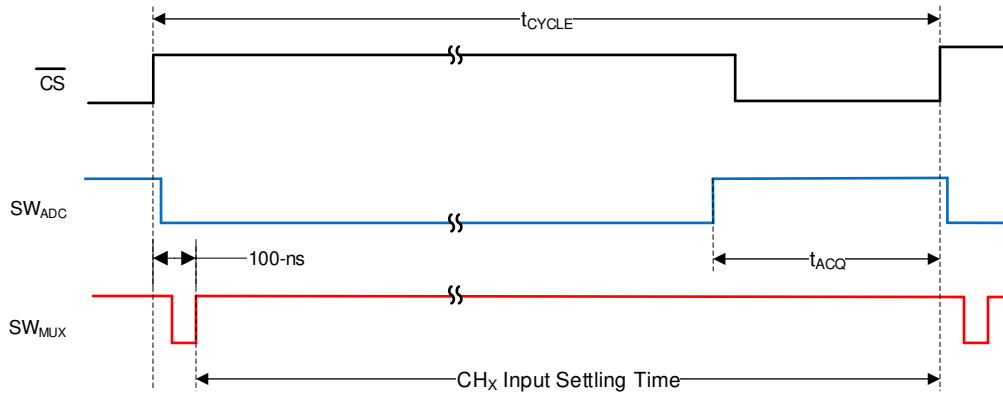

Figure 6-5. Early Switching of the MUX Enables a Long Acquisition Phase

6.3.2 Reference

The ADS816x has a precision, low-drift reference internal to the device. The device features an internal reference source with a nominal output value of 4.096V. On power-up, the internal reference is enabled by default. Place a minimum 1 μF decoupling capacitor, as illustrated in Figure 6-6, between the REFIO and REFM pins.

Figure 6-7 shows the connections for using the device with an external reference. Use a reference without a low-impedance output buffer because the input leakage current of the internal reference buffer is less than 1 μA .

For the minimum ADC input offset error (V_{OS}), set the REF_SEL[2:0] bits to the value closest to V_{REF} (see the OFST_CAL register). Set the REF_OFST[4:0] (see the REF_MRG1 register) bits to add or subtract an intentional offset voltage as described in Table 7-14. Short the two REFP pins externally. Short the REFM pin to GND externally. Place a decoupling capacitor C_{REFP} between the REFP and the REFM pins as close to the device as possible; see the Layout section for layout recommendations.

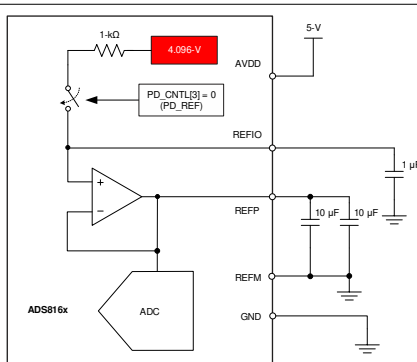

Figure 6-6. Internal Reference

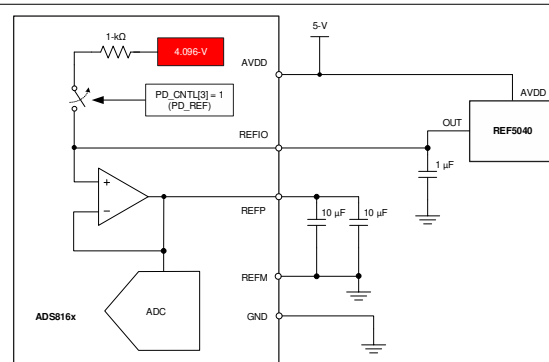
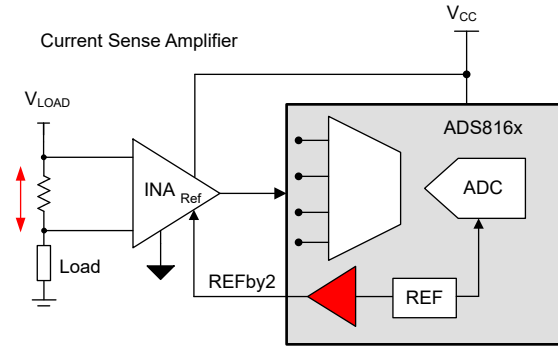

Figure 6-7. External Reference

6.3.3 REFby2 Buffer

To use the maximum dynamic range of the ADC, bias the input signal around the mid-scale of the ADC input range. In the ADS816x, where the absolute input range is 0V to the reference voltage (V_{REF}), mid-scale is $V_{REF} / 2$. The REFby2 buffer generates the $V_{REF} / 2$ signal for mid-scale shifting of the input signal. Figure 6-8 shows REFby2 used in various types of sensor signal conditioning circuits.



Configuration 1: High-side / Low-side Current sensing

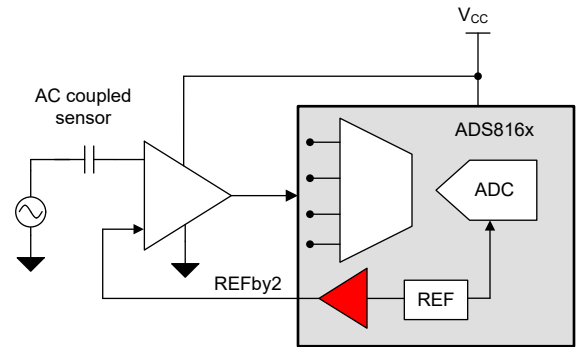

Configuration 2: AC Coupled Sensor Interface

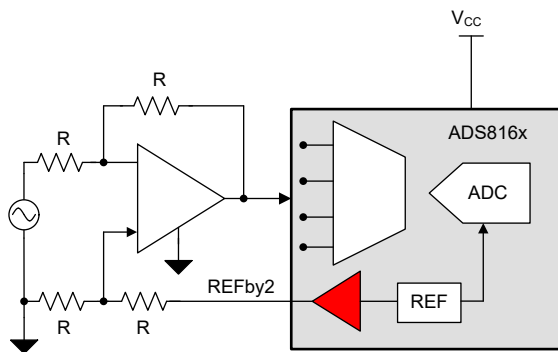

Configuration 3: Unity Gain Sensor Interface

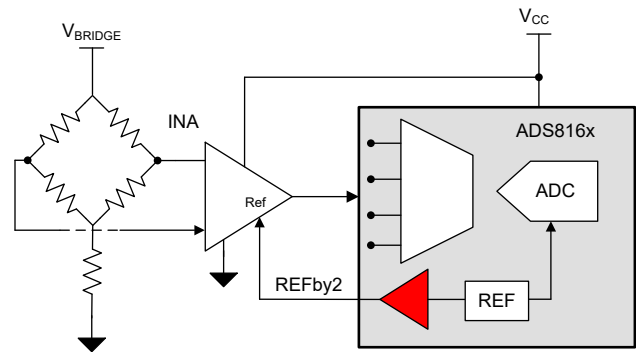

Configuration 4: High Impedance Sensor Interface with INA

Figure 6-8. Signal Conditioning With the REFby2 Buffer

A resistor divider at the output of the reference buffer, as shown in Figure 6-9, generates the $V_{REF} / 2$ signal. When not using the internal reference buffer (see the PD_CNTL register), any voltage applied at the REFP pin is applied to the resistor divider. The output of the resistor divider is buffered and available at the REFby2 pin.

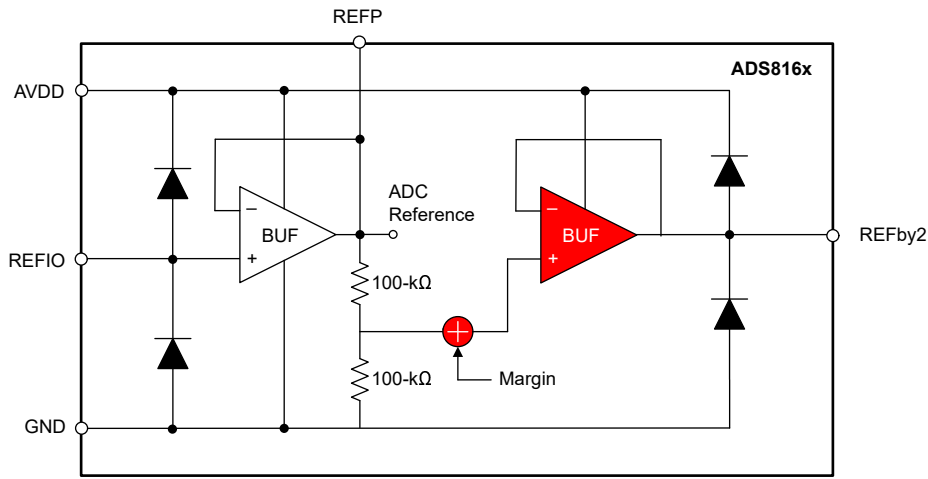

Figure 6-9. REFby2 Buffer Model

The REFby2 buffer is capable of sourcing up to 2mA of DC current. The REFby2 pin has ESD diode connections to AVDD and GND.

6.3.4 Converter Module

The converter module samples the analog input signal (provided between the ADC-INP and ADC-INM pins), compares this signal with the reference voltage (between the REFP pins and REFM pin), and generates an equivalent digital output code.

The converter module receives the \overline{RST} and \overline{CS} inputs from the interface module, and outputs the conversion result back to the interface module.

6.3.4.1 Internal Oscillator

The device features an internal oscillator (OSC) that provides the conversion clock. Conversion duration varies, but is bounded by the minimum and maximum value of t_{conv} .

6.3.4.2 ADC Transfer Function

The device supports single-ended and pseudo-differential analog inputs. The device output is in straight binary format. Figure 6-10 and Table 6-2 show the ideal transfer characteristics for a 16-bit ADC with unipolar inputs.

Equation 1 gives the least significant bit (LSB) for the ADC:

$$1 \text{ LSB} = V_{\text{REF}} / 2^{16} \tag{1}$$

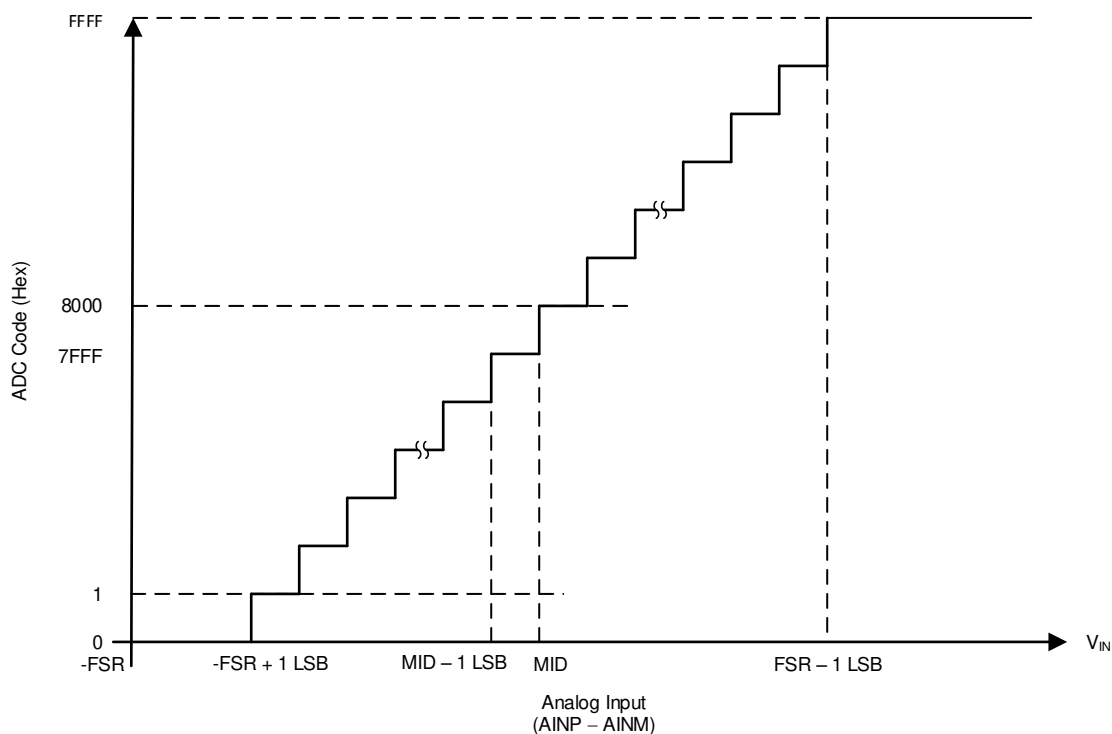

Figure 6-10. Converter Transfer Characteristics

Table 6-2. Transfer Characteristics

DESCRIPTION	SINGLE-ENDED INPUT VOLTAGE ($V_{\text{REF}} = 4.096\text{V}$)	PSEUDO-DIFFERENTIAL INPUT VOLTAGE ($V_{\text{REF}} = 4.096\text{V}$)	OUTPUT CODE (HEX)
FSR – 1 LSB	4.0959375V	2.0479375V	FFFF
MID + 1 LSB	2.0480625V	0.0000625V	8001
MID	2.048V	0V	8000
MID – 1 LSB	2.0479375V	–0.0000625V	7FFF
–FSR + 1 LSB	0.0000625V	–2.0479375V	0001
–FSR	0V	–2.048V	0000

6.3.5 Low-Dropout Regulator (LDO)

To enable single-supply operation, the device features an internal low-dropout regulator (LDO). The LDO is powered by the AVDD supply, and the 2.85V (nominal) output is available on the DECAP pin. This LDO output powers the critical analog blocks within the device. Do not use this LDO output for any other external purposes.

Decouple the DECAP pin with the GND pin, as shown in [Figure 6-11](#), by placing a 1µF, X7R-grade, ceramic capacitor with a 6.3V rating from DECAP to GND. There is no upper limit on the value of the decoupling capacitor; however, a larger decoupling capacitor results in higher power-up time for the device. See the [Layout](#) section for layout recommendations.

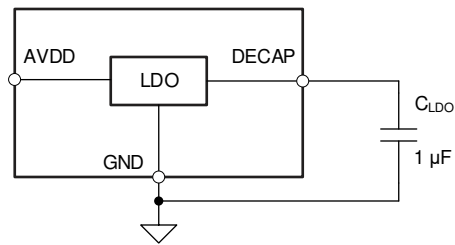

Figure 6-11. Internal LDO Connections

6.4 Device Functional Modes

The multiplexer includes a sequence control logic that supports various features as described in the [Channel Selection Using Internal Multiplexer](#) section.

6.4.1 Channel Selection Using Internal Multiplexer

The ADS816x includes an 8-channel, linear, and low-leakage current analog multiplexer. The multiplexer performs a break-before-make operation when switching channels. There are four modes of switching the multiplexer input channels: manual mode, on-the-fly mode, auto sequence mode, and custom channel sequencing mode.

Select these modes by configuring the SEQ_MODE[1:0] bits in the [DEVICE_CFG](#) register. On power-up the default mode is manual mode, SEQ_MODE[1:0] = 00b, and the default input channel is AIN0. The multiplexer configuration registers are accessible over the SPI; see [Figure 6-18](#). The SPI interface eliminates the need for separate MUX control lines.

6.4.1.1 Manual Mode

In manual mode, the channel ID of the desired analog input is configured in the `CHANNEL_ID` register. On power-up or after device reset, AIN0 is selected and `CHANNEL_ID[2:0] = 000b`. Enable manual mode from any other sequencing mode by programming the `SEQ_MODE[1:0]` bits to 00b in the `DEVICE_CFG` register. [Figure 6-12](#) shows the timing information for changing channels in manual mode.

Update the channel information in a microcontroller (MCU)-friendly 3-byte access. Because the 24 bits of channel configuration are sent over SDI, conversion data are clocked out over SDO. The data on SDO are MSB aligned and the first 16 clocks correspond to 16 bits of conversion data. The last eight bits of the SDO are ignored by the MCU.

As shown in [Figure 6-12](#), the command to switch to AINy is sent in the Nth cycle and the data corresponding to channel AINy is available in the (N + 2)th cycle. This switch occurs because the SDI commands are processed and the ADC starts conversions on the rising edge of \overline{CS} . Thus, the conversion is processed on the previous channel (AINx) and not on the updated channel ID (AINy).

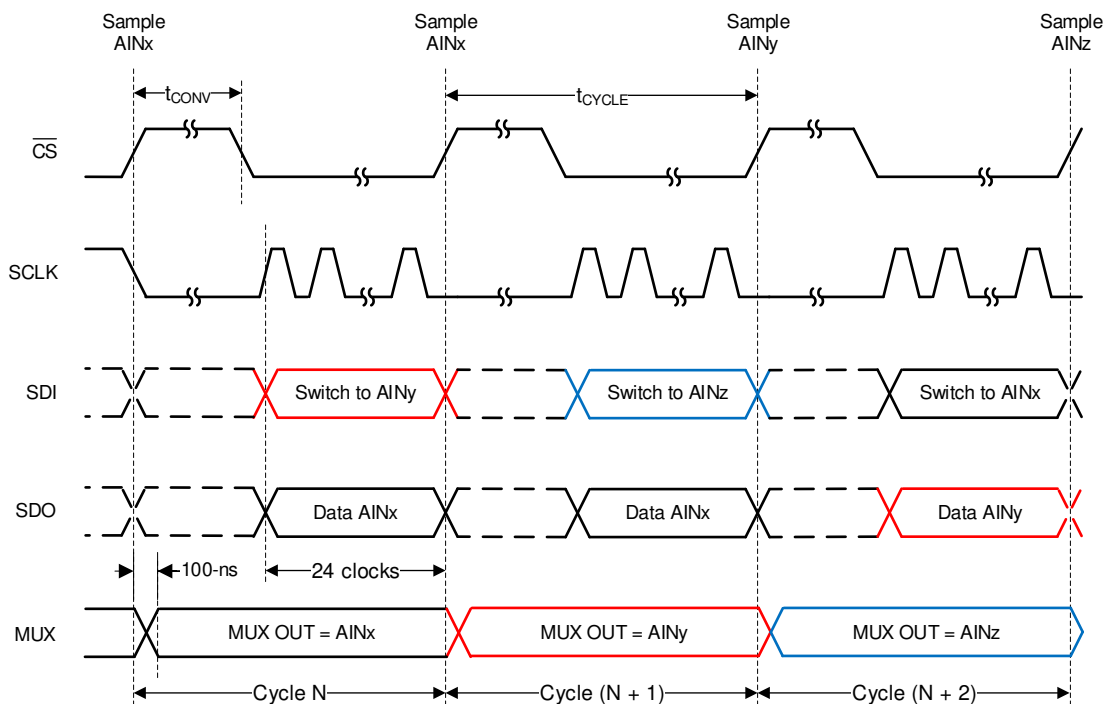

Figure 6-12. Manual Mode Timing Diagram

6.4.1.2 On-The-Fly Mode

There is a latency of one cycle when switching channels using the register access, just as in manual mode. The newly selected channel data are available two cycles after selecting the desired channel. The ADS816x supports on-the-fly switching of the analog input channels of the multiplexer. Enable this mode by programming the SEQ_MODE[1:0] bits to 01b in the DEVICE_CFG register. When enabled, the analog input channel for the next conversion is determined by the first five bits sent over SDI. The desired analog input channel is selected by setting the MSB to 1 and the following four bits as the channel ID. If the MSB is 0 then the SDI bitstream is decoded as a normal frame on the rising edge of CS. Table 6-3 lists the channel selection commands for this mode.

Table 6-3. On-the-Fly Mode Channel Selection Commands

SDI BITS [15:11]	SDI BITS [10:0]	DESCRIPTION
1 0000	Don't care	Select analog input 0
1 0001	Don't care	Select analog input 1
1 0010	Don't care	Select analog input 2
1 0011	Don't care	Select analog input 3
1 0100	Don't care	Select analog input 4
1 0101	Don't care	Select analog input 5
1 0110	Don't care	Select analog input 6
1 0111	Don't care	Select analog input 7
1 1000 to 1 1111	Don't care	Error bit is set; select analog input 0

To set the device in on-the-fly mode, configure EN_ON_THE_FLY to 1b in the ON_THE_FLY_CFG register as shown in Figure 6-13 using a 3-byte register access. When in this mode, use the 16-bit data transfer to reduce the required clock speed for operating at full throughput.

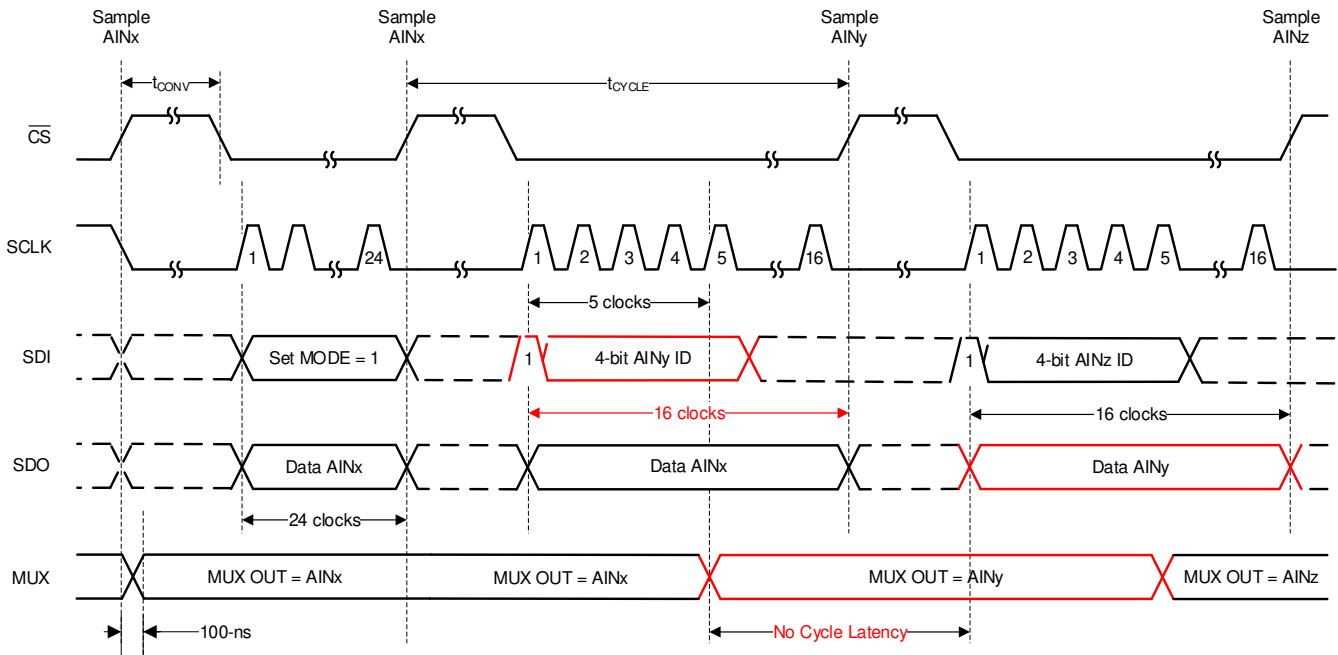

Figure 6-13. On-the-Fly Mode With No MUX Channel Selection Latency

6.4.1.3 Auto Sequence Mode

In auto sequence mode, the internal channel sequencer selectively scans channels from AIN0 through AIN7 in ascending order. To select auto sequence mode, configure SEQ_MODE to 10b in the [DEVICE_CFG](#) register using a 3-byte register access. Enable one or more channels among AIN[7:0] by configuring the [AUTO_SEQ_CFG1](#) register. By default all analog input channels are enabled. After enabling the desired channels, start the sequence by setting SEQ_START to 1b. The ADC auto-increments through the enabled channels after every \overline{CS} rising edge. Configure SEQSTS_CFG bit to 1b in [SDO_CNTL4](#) register to indicate sequence status on SDO-1/SEQSTS pin. When SEQ_START is set to 1b, the SDO-1/SEQSTS pin is at logic 1 as shown in [Figure 6-14](#) until the last channel conversion frame is complete. After the last enabled channel conversion is complete, channel AIN0 is selected and SDO-1/SEQSTS is in a high-impedance state.

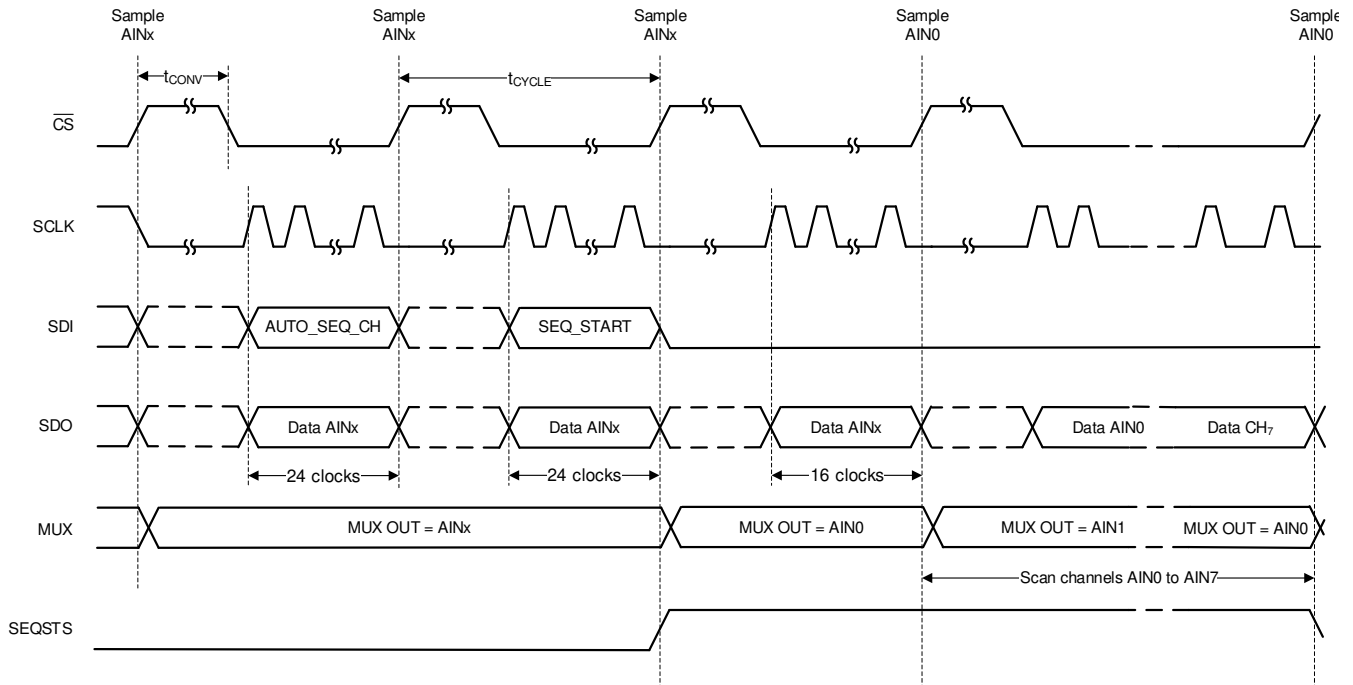

Figure 6-14. Starting a Sequence in Auto Sequence Mode

As an example, [Figure 6-15](#) depicts a timing diagram for when the device is scanning AIN2 and AIN6 in auto sequence mode. When AIN6 is converted, SDO-1/SEQSTS is Hi-Z and AIN0 is selected as the active channel. At the end of sequence, if more conversion frames are launched the device returns valid data corresponding to AIN0.

To use the device in auto sequence mode follow these steps:

- Set the SEQ_MODE[1:0] bits in the [DEVICE_CFG](#) register to 10b.
- Configure the [AUTO_SEQ_CFG1](#) register. In [Figure 6-15](#), [AUTO_SEQ_CFG1](#) = 0x44.
- Set the SEQ_START bits in the [SEQ_START](#) register to 1b to start executing the sequence.
- Optionally, configure SEQSTS_CFG bit to 1b in [SDO_CNTL4](#) register to indicate sequence status on SDO-1/SEQSTS pin.

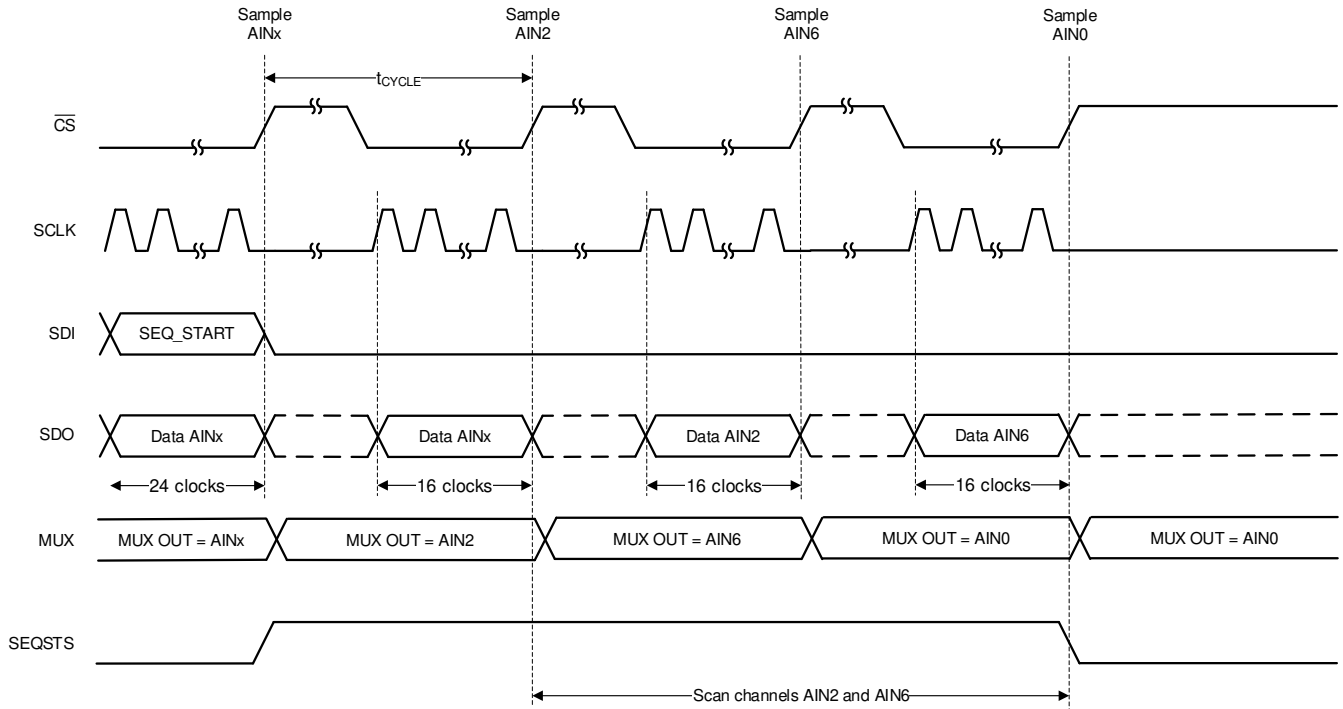

Figure 6-15. Example: Scanning Channels 2 and 6 in Auto Sequence Mode

To repeat a channel sequence indefinitely, set the **AUTO_REPEAT** bit in the **AUTO_SEQ_CFG2** register to 1b. **Figure 6-16** shows that when the **AUTO_REPEAT** bit is enabled, the MUX scans through the channels enabled in the **AUTO_SEQ_CFG1** register and repeats the sequence after the last channel data are converted.

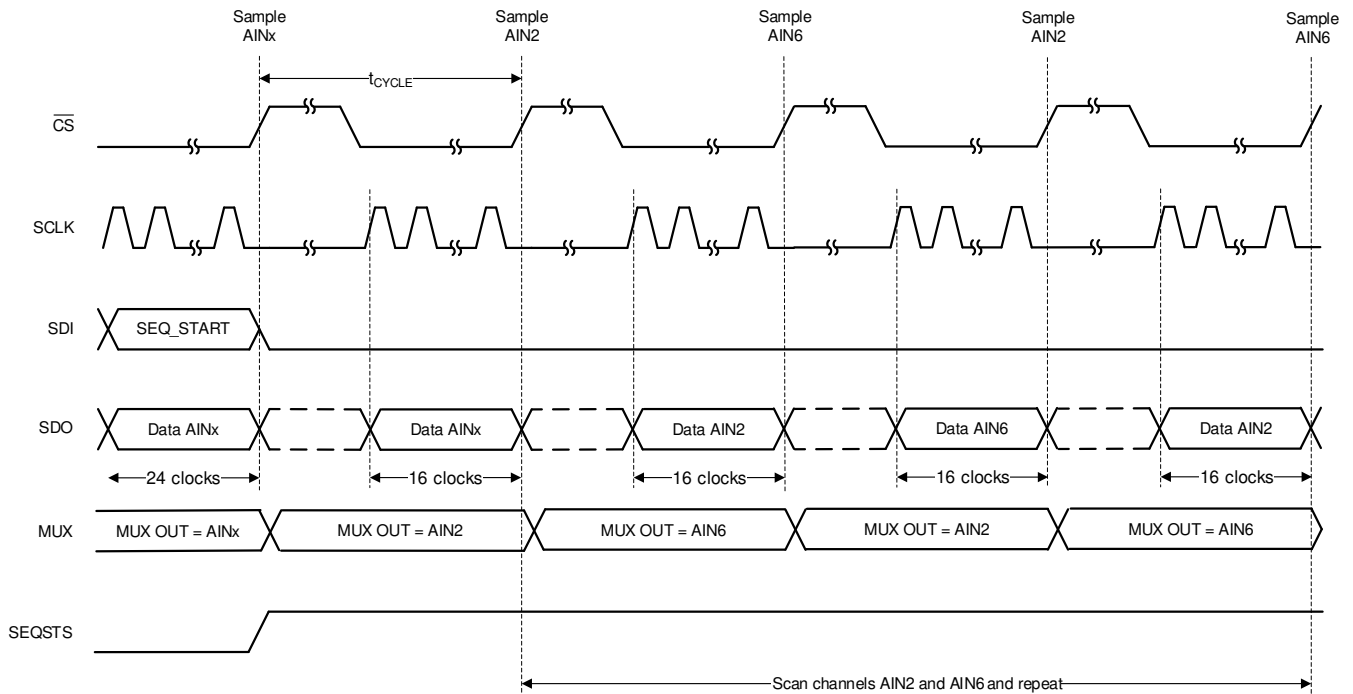

Figure 6-16. Example: Scanning Channels 2 and 6 in Auto Sequence Mode With **AUTO_REPEAT = 1**

Figure 6-16 provides a timing diagram for when the device is scanning AIN2 and AIN6 in auto sequence mode with `AUTO_REPEAT = 1b`. When AIN6 is converted, AIN2 is selected as the active channel and the device continues scanning through the enabled channels again.

To use the device in auto sequence with the repeat mode enabled follow these steps:

- Set the `SEQ_MODE[1:0]` bits in the `DEVICE_CFG` register to `10b`.
- Configure the `AUTO_SEQ_CFG1` register. In Figure 6-15, `AUTO_SEQ_CFG1 = 0x44`.
- Set `AUTO_REPEAT` to `1b`.
- Set the `SEQ_START` bit in the `SEQ_START` register to `1b` to start executing the sequence.
- Optionally, configure `SEQSTS_CFG` bit to `1b` in `SDO_CNTL4` register to indicate sequence status on SDO-1/SEQSTS pin.

To terminate an ongoing channel sequence set the `SEQ_ABORT` bit in the `SEQ_ABORT` register 1. When `SEQ_ABORT` is set, the auto sequence stops and AIN0 is selected as the active input channel.

6.4.1.4 Custom Channel Sequencing Mode

In this mode the internal channel sequencer selectively scans channels from AIN0 through AIN7 in any order as defined by a user-programmable look-up table. Table 6-4 describes the configurability of this look-up table. Configure the device in custom channel sequencing mode by programming the `SEQ_MODE[1:0]` bits to `11b` in the `DEVICE_CFG` register using a 3-byte register access. Table 6-4 shows that the channel scanning sequence is programmed by configuring the channel IDs in the register as space. A channel sample count is also programmed and associated with every channel ID. By default the channel sample count is 1, which means the sequence executes in the order of programmed channel IDs. If the channel sample count is greater than 1 then the corresponding channel is sampled and converted for a programmed number of times before switching to the next channel.

Table 6-4. Custom Channel Sequencing Configuration Space

REGISTER ADDRESS	CHANNEL ID[2:0]	REGISTER ADDRESS	CHANNEL SAMPLE COUNT[7:0]
0x8C	Index 0 : 3-bit channel ID (default = 0)	0x8D	Index 0 : 8-bit sample count (default = 0xFF)
0x8E	Index 1 : 3-bit channel ID (default = 0)	0x8F	Index 1 : 8-bit sample count (default = 0xFF)
0x90	Index 2 : 3-bit channel ID (default = 0)	0x91	Index 2 : 8-bit sample count (default = 0xFF)
0x92	Index 3 : 3-bit channel ID (default = 0)	0x93	Index 3 : 8-bit sample count (default = 0xFF)
0x94	Index 4 : 3-bit channel ID (default = 0)	0x95	Index 4 : 8-bit sample count (default = 0xFF)
0x96	Index 5 : 3-bit channel ID (default = 0)	0x97	Index 5 : 8-bit sample count (default = 0xFF)
0x98	Index 6 : 3-bit channel ID (default = 0)	0x99	Index 6 : 8-bit sample count (default = 0xFF)
0x9A	Index 7 : 3-bit channel ID (default = 0)	0x9B	Index 7 : 8-bit sample count (default = 0xFF)
0x9C	Index 8 : 3-bit channel ID (default = 0)	0x9D	Index 8 : 8-bit sample count (default = 0xFF)
0x9E	Index 9 : 3-bit channel ID (default = 0)	0x9F	Index 9 : 8-bit sample count (default = 0xFF)
0xA0	Index 10 : 3-bit channel ID (default = 0)	0xA1	Index 10 : 8-bit sample count (default = 0xFF)
0xA2	Index 11 : 3-bit channel ID (default = 0)	0xA3	Index 11 : 8-bit sample count (default = 0xFF)
0xA4	Index 12 : 3-bit channel ID (default = 0)	0xA5	Index 12 : 8-bit sample count (default = 0xFF)
0xA6	Index 13 : 3-bit channel ID (default = 0)	0xA7	Index 13 : 8-bit sample count (default = 0xFF)
0xA8	Index 14 : 3-bit channel ID (default = 0)	0xA9	Index 14 : 8-bit sample count (default = 0xFF)
0xAA	Index 15 : 3-bit channel ID (default = 0)	0xAB	Index 15 : 8-bit sample count (default = 0xFF)

For application-specific scanning requirements, use start and stop pointers to define the channel scanning sequence. Program the start index in the [CCS_START_INDEX](#) register and the stop index in the [CCS_END_INDEX](#) register. [Table 6-4](#) shows that the 4-bit index corresponds to the configuration index. The sequence starts executing from the index programmed in [CCS_START_INDEX](#) (default 0) and stop or loop-back from [CCS_STOP_INDEX](#) (default 15). The channel scanning sequence is looped-back to the start index from the stop index by setting the [CCS_SEQ_LOOP](#) register to 1b.

After configuring the channel scanning order, start index, and stop index, initiate the scanning by setting the [SEQ_START](#) bit to 1b. The ADC scans through the enabled channels after every \overline{CS} rising edge as defined by the channel scanning order. When [SEQ_START](#) is set to 1b, the [SDO-1/SEQSTS](#) pin is pulled high until the last channel conversion frame is complete, as described in [Figure 6-14](#). As illustrated in [Figure 6-15](#), channel [AIN0](#) is selected and [SEQSTS/SDO-1](#) goes to Hi-Z after the last enabled channel conversion is complete.

As an example, [Figure 6-15](#) provides a timing diagram for when the channel configuration is set as in [Table 6-5](#). When [AIN6](#) is converted, [SEQSTS/SDO-1](#) goes to Hi-Z and [AIN0](#) is selected as the active channel. If more conversion frames are launched at the end of the sequence, the device returns valid data corresponding to [AIN0](#).

To use the device in easy capture mode follow these steps:

- Set the [SEQ_MODE\[1:0\]](#) bits in the [DEVICE_CFG](#) register to 3.
- Configure the channel sequence by setting registers 0x000C to 0x002B.
- Configure the [CCS_START_INDEX](#) and the [CCS_END_INDEX](#) registers. In [Figure 6-15](#), [CCS_START_INDEX](#) = 0 and [CCS_STOP_INDEX](#) = 1.
- Configure the [CCS_SEQ_LOOP](#) register to 1 to indefinitely loop the sequence. In [Figure 6-15](#), the [CCS_SEQ_LOOP](#) register = 0b.
- Set the [SEQ_START](#) register to 1b to start executing the sequence.

Table 6-5. Custom Channel Sequencing Configuration Example

REGISTER ADDRESS	CHANNEL ID[2:0]	REGISTER ADDRESS	CHANNEL SAMPLE COUNT[7:0]
0x8C	010b (channel 2)	0x8D	1
0x8E	110b (channel 6)	0x8F	1

6.4.2 Digital Window Comparator

The ADS816x has a programmable digital window comparator for every analog input channel. The integrated digital window comparator allows the host to not read ADC data over the serial interface for comparison purposes. In monitoring applications, the ADC compares channel data with the set thresholds and alerts the system host using the ALERT pin. Furthermore, the digital window comparator does not require software high and low comparisons and thus saves processing cycles.

Window comparison is achieved by comparing the channel output code with a programmable high and low digital threshold. As shown in Figure 6-17, each analog input channel has a programmable hysteresis that is applicable to both the high and low thresholds of the corresponding channel. Thus, low threshold, high threshold, and hysteresis configurations are available for each analog input channel.

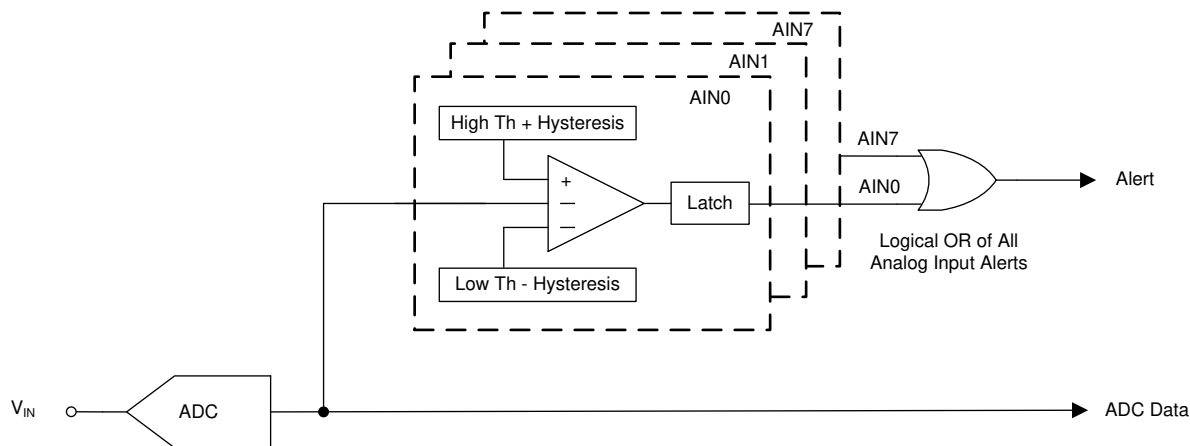

Figure 6-17. Digital Window Comparator

The thresholds and hysteresis are configured independently for each analog input channel. The ALERT output of the device is a logical OR of all enabled alert outputs corresponding to the analog inputs. The window comparator is selectively enabled for the analog inputs by configuring the [ALERT_CFG](#) register.

Read the alert status of an individual analog input channel from the [ALERT_STATUS](#) register. See the [ALERT_HI_STATUS](#) and [ALERT_LO_STATUS](#) registers for further information on the high or low threshold ALERT, respectively. When monitoring only a low threshold, set the high threshold to the ADC positive full-scale code. Similarly, when monitoring only a high threshold, set the low threshold to the negative full-scale code.

6.5 Programming

6.5.1 Data Transfer Protocols

6.5.1.1 Enhanced-SPI Interface

The device features an enhanced-SPI interface that allows the host controller to operate at slower SCLK speeds and still achieve the required cycle time with a faster response time. [Figure 6-18](#) shows the ADS816x Interface connections for the minimum number of pins required by the enhanced-SPI interface.

For any data write operation, the host controller uses any of the four legacy, SPI-compatible protocols to configure the device, as described in the [Protocols for Configuring the Device](#) section. See the [Register Read/Write Operation](#) section for details about the register read or write operation.

For reading ADC conversion data or register data from the device, the enhanced-SPI interface module offers the following options:

- SPI protocol with a single data output line: SDO-0 (see the [SPI Protocols With a Single SDO](#) section)
- SPI protocol with dual data output lines: SDO-1 and SDO-0 (see the [SPI Protocols With Dual SDO](#) section)
- Clock re-timer data transfer (see the [Clock Re-Timer Data Transfer](#) section)

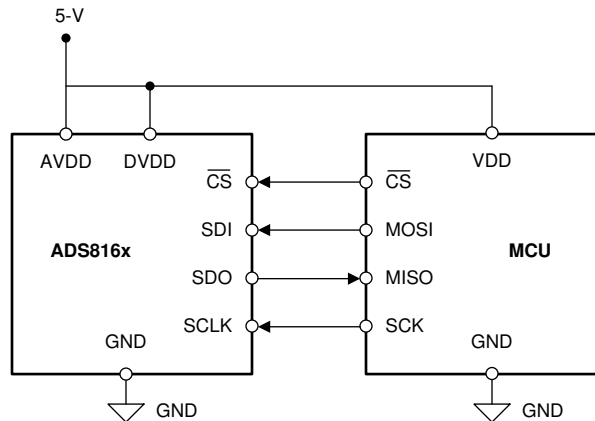

Figure 6-18. 4-Wire SPI Interface Connection Diagram

6.5.1.1.1 Protocols for Configuring the Device

As described in [Table 6-6](#), the host controller uses any of the four SPI protocols (SPI-00, SPI-01, SPI-10, or SPI-11) to write data into the device.

Table 6-6. SPI Protocols for Configuring the Device

PROTOCOL	SCLK POLARITY (At the \overline{CS} Falling Edge)	SCLK PHASE (Capture Edge)	SDI_MODE[1:0] BITS ⁽¹⁾	SDO_MODE[1:0] BITS ⁽²⁾	DIAGRAM
SPI-00	Low	Rising	00h	00h	Figure 6-19
SPI-01	Low	Falling	01h	00h	Figure 6-19
SPI-10	High	Falling	02h	00h	Figure 6-20
SPI-11	High	Rising	03h	00h	Figure 6-20

(1) See the [SDI_CNTL](#) register.

(2) See the [SDO_CNTL1](#) register.

On power-up or after coming out of any asynchronous reset, the device supports the SPI-00-S protocol for data read and data write operations. To select a different SPI-compatible protocol, program the SDI_MODE[1:0] bits in the [SDI_CNTL](#) register. Make sure this first write operation adheres to the SPI-00-S protocol. Make sure any subsequent data transfer frames adhere to the newly selected protocol. The SPI protocol selected by the SDI_MODE[1:0] configuration is applicable to both read and write operations.

[Figure 6-19](#) and [Figure 6-20](#) detail the four protocols using an optimal data frame.

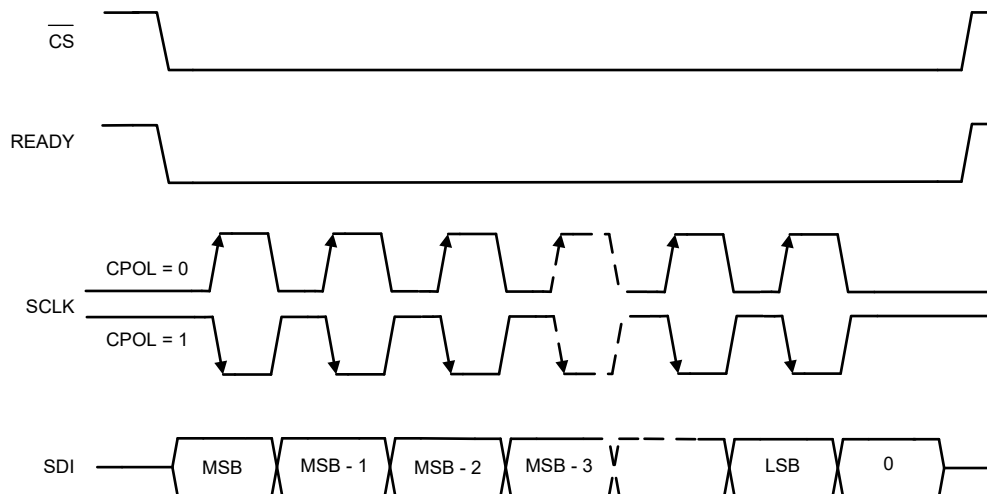

Figure 6-19. Standard SPI Timing Protocol (CPHA = 0)

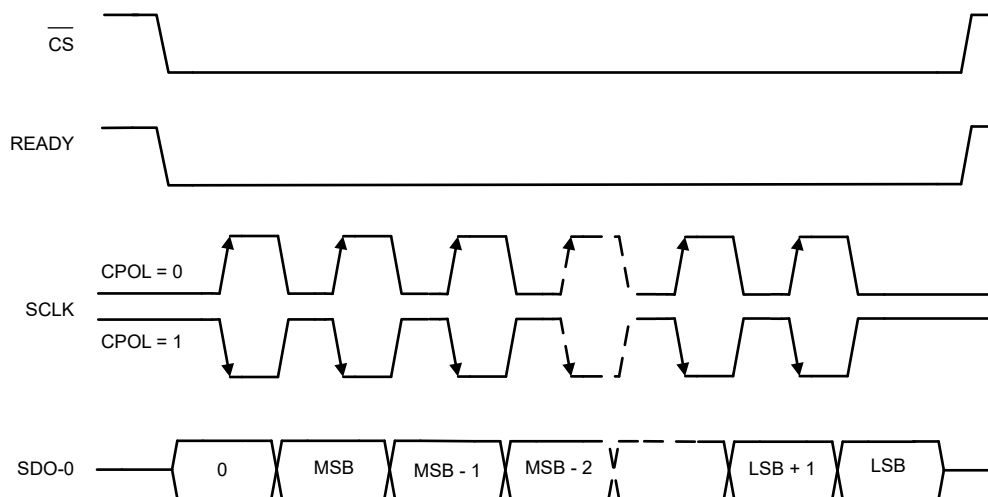

Figure 6-20. Standard SPI Timing Protocol (CPHA = 1)

Note

As explained in the [Register Read/Write Operation](#) section, a valid register read or write operation to the device requires 24 SCLKs to be provided within a data transfer frame. When reading ADC conversion data, a minimum 16 SCLKs are required within a data transfer frame.

6.5.1.1.2 Protocols for Reading From the Device

The protocols for the data read operation are broadly classified into three categories:

1. SPI protocols (SPI-00, SPI-01, SPI-10, and SPI-11) with a single SDO (see the [SPI Protocols With a Single SDO](#) section); for example, SDO-0
2. SPI protocols (SPI-00, SPI-01, SPI-10, and SPI-11) with dual SDOs (see the [SPI Protocols With Dual SDO](#) section); for example, SDO-1 and SDO-0
3. Source-synchronous protocol for data transfer

6.5.1.1.2.1 SPI Protocols With a Single SDO

As shown in [Table 6-7](#), [Figure 6-21](#), and [Figure 6-22](#), the host controller uses any of the four legacy, SPI-compatible protocols (SPI-00, SPI-01, SPI-10, or SPI-11) to read data from the device.

Table 6-7. SPI Protocols for Reading From the Device

PROTOCOL	SCLK POLARITY (At the \overline{CS} Falling Edge)	SCLK PHASE (Launch Edge)	MSB BIT LAUNCH EDGE	SDI_MODE[1:0] BITS	SDO_MODE[1:0] BITS	DIAGRAM
SPI-00	Low	Rising	\overline{CS} falling	00h	00h	Figure 6-21
SPI-01	Low	Falling	1st SCLK rising	01h	00h	Figure 6-21
SPI-10	High	Falling	\overline{CS} falling	02h	00h	Figure 6-22
SPI-11	High	Rising	1st SCLK falling	03h	00h	Figure 6-22

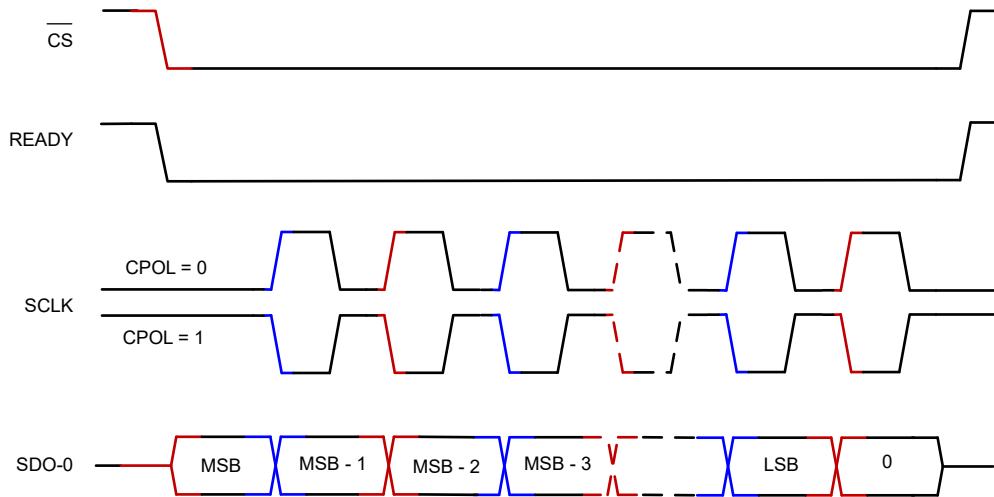

Figure 6-21. Standard SPI Timing Protocol (CPHA = 0, Single SDO-0)

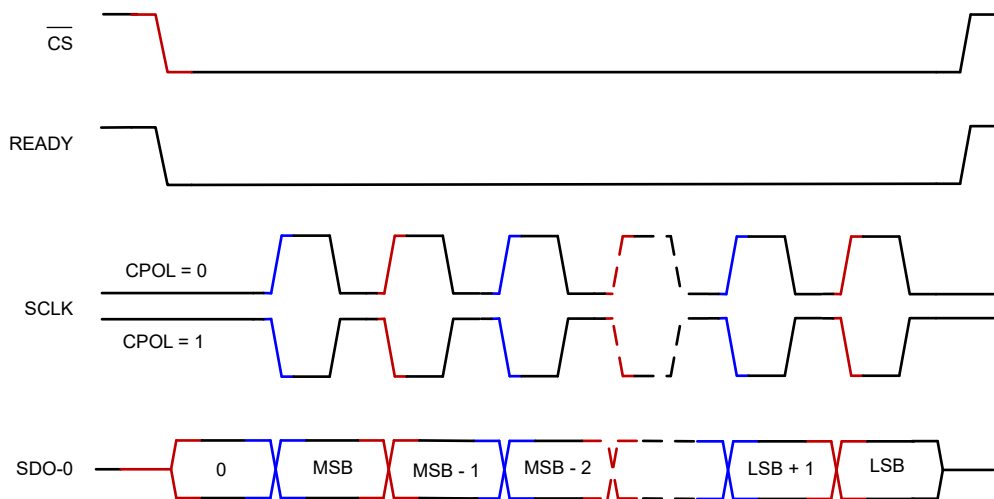

Figure 6-22. Standard SPI Timing Protocol (CPHA = 1, Single SDO-0)

On power-up or after coming out of any asynchronous reset, the device supports the SPI-00 protocol for data read and data write operations. To select a different SPI-compatible protocol for both of the data transfer operations:

1. Program the SDI_MODE[1:0] bits in the [SDI_CNTL](#) register. Make sure this first write operation adheres to the SPI-00 protocol. Make sure any subsequent data transfer frames adhere to the newly-selected protocol.
 2. Set the SDO_MODE[1:0] bits = 00b in the [SDO_CNTL1](#) register.
-

Note

The SPI transfer protocol selected by configuring the SDI_MODE[1:0] bits in the [SDI_CNTL](#) register determines the data transfer protocol for both write and read operations.

When using any of the SPI-compatible protocols, the READY output remains low throughout the data transfer frame.

6.5.1.1.2.2 SPI Protocols With Dual SDO

The device provides an option to increase the SDO bus width from one bit (default, single SDO-0) to two bits (dual SDO) when operating with any of the data transfer protocols. To operate the device in dual SDO mode, set the SDO_WIDTH bit in the SDO_CNTL1 register to 1b. In this mode, the SDO-1/SEQSTS pin functions as SDO-1.

As shown in Figure 6-23 and Figure 6-24, two bits of data are launched on the two SDO pins (SDO-0 and SDO-1) on every SCLK launch edge in dual SDO mode.

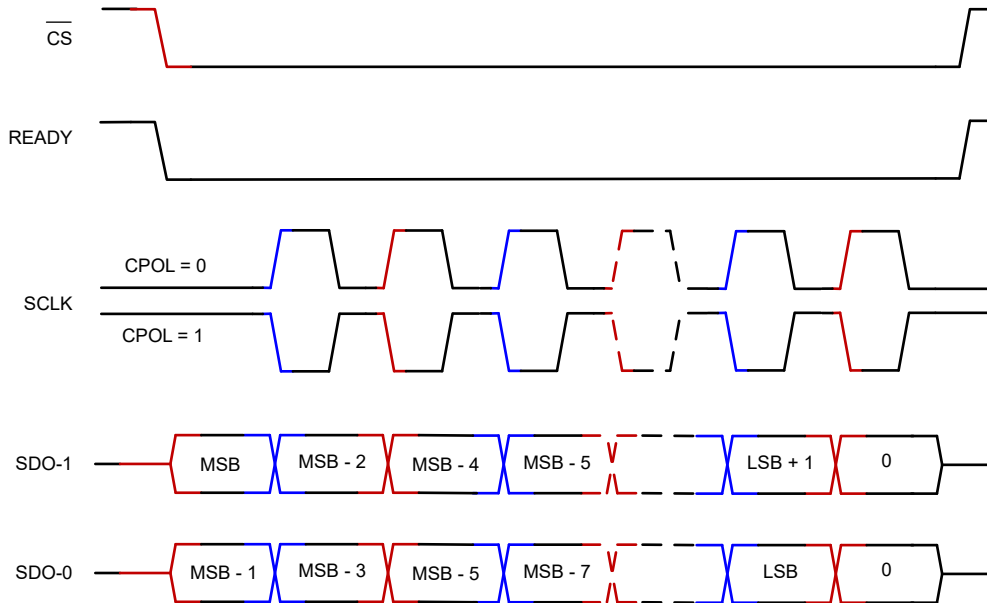

Figure 6-23. Standard SPI Timing Protocol (CPHA = 0, Dual SDO)

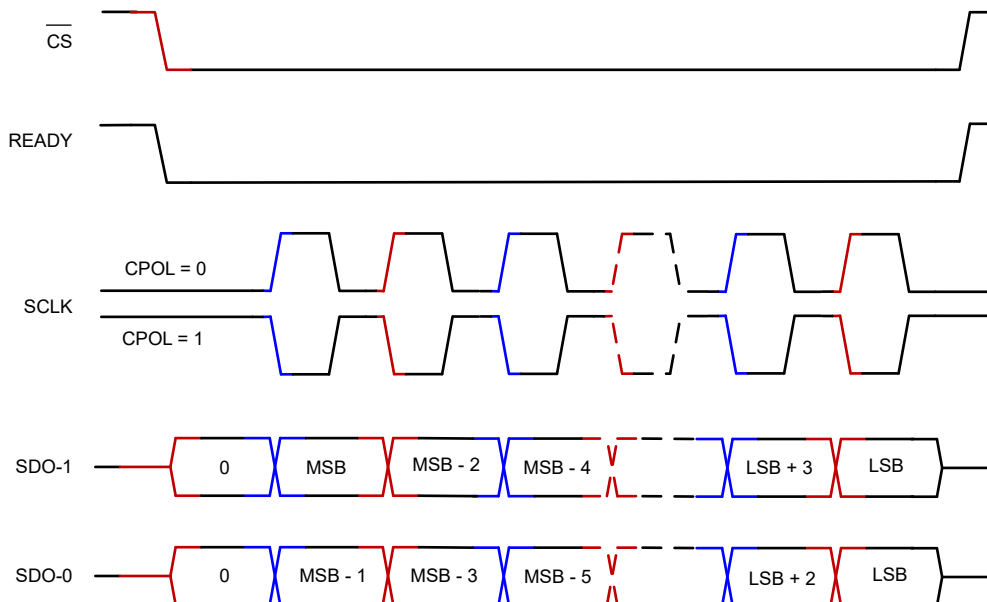

Figure 6-24. Standard SPI Timing Protocol (CPHA = 1, Dual SDO)

6.5.1.1.2.3 Clock Re-Timer Data Transfer

In clock re-timer data transfer mode, the device provides an output clock that is synchronous with the output data. Furthermore, the host controller also selects the data bus width in this mode of operation. In all modes of operation, the READY pin provides the output clock, synchronous to the device data output.

The clock re-timer data transfer allows the width of the output bus to be configured, similar to the SPI protocols SPI protocols described in [Table 6-6](#).

6.5.1.1.2.3.1 Output Bus Width Options

The device provides an option to increase the SDO-x bus width from one bit (default, single SDO-x) to two bits (dual SDO-x) when operating with clock re-timer data transfer. To operate the device in dual SDO mode, set the SDO_WIDTH bit in the [SDO_CNTL1](#) register to 1b. In this mode, the SDO-1/SEQSTS pin functions as SDO-1.

Note

For any particular data transfer, SPI or clock re-timer, the device follows the same timing specifications for single and dual SDO modes. The only difference is that in the dual SDO mode the device requires half as many clock cycles to output the same number of bits when in single SDO mode, thus reducing the minimum required clock frequency for a certain sampling rate of the ADC.

6.5.2 Register Read/Write Operation

This device features configuration registers (as described in the [Interface and Hardware Configuration Registers](#) section). These devices support the commands listed in [Table 6-8](#) to access the internal configuration registers.

Table 6-8. Supported Commands

B[23:19]	B[18:8]	B[7:0]	COMMAND ACRONYM	COMMAND DESCRIPTION
00000	00000000000	00000000	NOP	No operation
00001	<11-bit address>	<8-bit data>	WR_REG	Write <8-bit data> to the <11-bit address>
00010	<11-bit address>	00000000	RD_REG	Read contents from the <11-bit address>
00011	<11-bit address>	<8-bit unmasked bits>	SET_BITS	Set <8-bit unmasked bits> from <11-bit address>
00100	<11-bit address>	<8-bit unmasked bits>	CLR_BITS	Clear <8-bit unmasked bits> from <11-bit address>
Remaining combinations	xxxxxxxxx	xxxxxxxxx	Reserved	These commands are reserved and treated by the device as no operation

The ADS816x supports two types of data transfer operations: *data write* (the host controller configures the device), and *data read* (the host controller reads data from the device).

Any data write to the device is always synchronous to the external clock provided on the SCLK pin. The WR_REG command writes the 8-bit data into the 11-bit address specified in the command string. The CLR_BITS command clears the specified bits (identified by 1) at the 11-bit address (without affecting the other bits), and the SET_BITS command sets the specified bits (identified by 1) at the 11-bit address (without affecting the other bits).

[Figure 6-25](#) shows the digital waveform for register read operation. Register read operation consists of two frames: one frame to initiate a register read and a second frame to read data from the register address provided in the first frame. As shown in [Figure 6-25](#), the 11-bit register address and the 8-bit dummy data are sent over the SDI pin during the first 24-bit frame with the read command (00010b). When \overline{CS} goes from low to high, this read command is decoded and the requested register data are available for reading during the next frame. During the second frame, the first eight bits on SDO correspond to the requested register read. During the second frame, use SDI to initiate another operation or set SDI to 0.

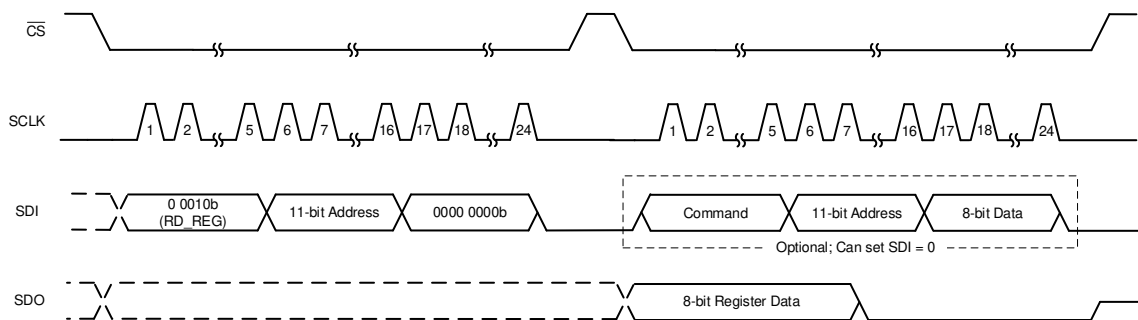

Figure 6-25. Register Read Operation

Figure 6-26 shows that for writing data to the register, one 24-bit frame is required. The 24-bit data on SDI consists of a 5-bit write command (00001b), an 11-bit register address, and 8-bit data. The write command is decoded on the \overline{CS} rising edge and the specified register is updated with the 8-bit data specified during register write operation.

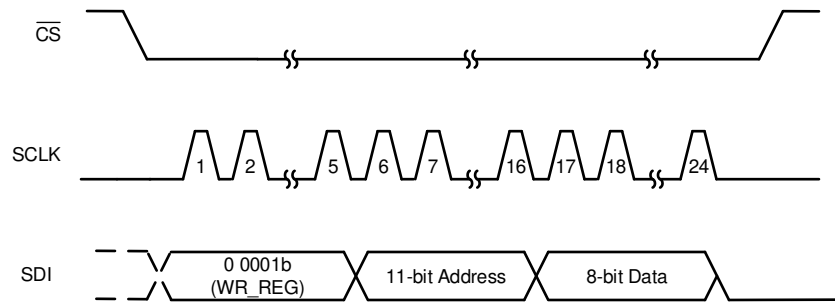

Figure 6-26. Register Write Operation

7 Register Maps

Table 7-1 lists the access codes for the ADS816x registers.

Table 7-1. ADS816x Access Type Codes

Access Type	Code	Description
Read Type		
R	R	Read
R-W	R/W	Read or write
Write Type		
W	W	Write
Reset or Default Value		
-n		Value after reset or the default value

7.1 Interface and Hardware Configuration Registers

Table 7-2 maps the device features following a hardware configuration of the registers.

Table 7-2. Configuration Registers Mapping

ADDRESS	REGISTER NAME	REGISTER DESCRIPTION
00h	REG_ACCESS	Enables read/write access to the device configuration registers specified in the <i>Interface and Hardware Configuration Registers</i> section
04h	PD_CNTL	Enable/disable control for reference, reference buffer, REFby2 buffer, and the ADC
08h	SDI_CNTL	SPI-00, SPI-01, SPI-10, or SPI-11 protocol selection.
0Ch	SDO_CNTL1	SDO output protocol selection
0Dh	SDO_CNTL2	Output data rate selection
0Eh	SDO_CNTL3	Reserved
0Fh	SDO_CNTL4	Configuration for the SEQSTS pin when not using SDO-1 for data transfer.
10h	DATA_CNTL	Output data word configuration
11h	PARITY_CNTL	Parity configuration register

7.1.1 REG_ACCESS Register (address = 00h) [reset = 00h]

This register enables or disables write access to the device configuration registers specified in Table 7-2.

Figure 7-1. REG_ACCESS Register

7	6	5	4	3	2	1	0
REG_ACCESS_BITS							
R/W-0000 0000b							

Table 7-3. REG_ACCESS Register Field Descriptions

Bit	Field	Type	Reset	Description
7-0	REG_ACCESS_BITS	R/W	0000 0000b	Enables or disables write access to the device configuration registers specified in Table 7-2. Write 1010 1010b to this register to enable write access. Write access is disabled for all values other than REG_ACCESS_BITS = 1010 1010b.

7.1.2 PD_CNTL Register (address = 04h) [reset = 00h]

This register controls the low-power modes offered by the device. Write access to this register is disabled on power-up. To enable write access, configure the [REG_ACCESS](#) register.

Figure 7-2. PD_CNTL Register

7	6	5	4	3	2	1	0
0	0	0	PD_REFby2	PD_REF	PD_REFBUF	PD_ADC	0
R-0b	R-0b	R-0b	R/W-0b	R/W-0b	R/W-0b	R/W-0b	R-0b

Table 7-4. PD_CNTL Register Field Descriptions

Bit	Field	Type	Reset	Description
7-5	0	R	000b	Reserved bits. Reads return 000b.
4	PD_REFby2	R/W	0b	This bit powers down the internal REFby2 buffer. 0b = REFby2 buffer is powered up 1b = REFby2 buffer is powered down
3	PD_REF	R/W	0b	This bit powers down the internal reference. 0b = Internal reference is powered up 1b = Internal reference is powered down
2	PD_REFBUF	R/W	0b	This bit powers down the internal reference buffer. 0b = Internal reference buffer is powered up 1b = Internal reference buffer is powered down
1	PD_ADC	R/W	0b	This bit powers down the converter module. 0b = Converter module is powered up 1b = Converter module is powered down
0	0	R	0b	Reserved bits. Do not write. Reads return 0b.

To power-down the converter module, set the PD_ADC bit in the [PD_CNTL](#) register. The converter module powers down on the rising edge of \overline{CS} . To power-up the converter module, reset the PD_ADC bit in the PD_CNTL register. The converter module starts to power-up on the rising edge of \overline{CS} . Wait for t_{PU_ADC} before initiating any conversion or data transfer operation.

To power-down the internal reference buffer, set the PD_REFBUF bit in the PD_CNTL register. The internal reference buffer powers down on the rising edge of \overline{CS} .

To power-down the internal reference, set the PD_REF bit in the PD_CNTL register. The internal reference powers down on the rising edge of \overline{CS} .

7.1.3 SDI_CNTL Register (address = 008h) [reset = 00h]

This register selects the SPI protocol for writing data to the device. Write access to this register is disabled on power-up. To enable write access, configure the [REG_ACCESS](#) register.

Figure 7-3. SDI_CNTL Register

7	6	5	4	3	2	1	0
0	0	0	0	0	0	SDI_MODE[1:0]	
R-0b	R-0b	R-0b	R-0b	R-0b	R-0b	R/W-00b	

Table 7-5. SDI_CNTL Register Field Descriptions

Bit	Field	Type	Reset	Description
7-2	0	R	000000b	Reserved bits. Do not write. Reads return 000000b.
1-0	SDI_MODE[1:0]	R/W	00b	These bits select the protocol for writing data into the device. 00b = Standard SPI with CPOL = 0 and CPHASE = 0 01b = Standard SPI with CPOL = 0 and CPHASE = 1 10b = Standard SPI with CPOL = 1 and CPHASE = 0 11b = Standard SPI with CPOL = 1 and CPHASE = 1

7.1.4 SDO_CNTL1 Register (address = 0Ch) [reset = 00h]

This register configures the protocol for reading data from the device. Write access to this register is disabled on power-up. To enable write access, configure the [REG_ACCESS](#) register.

Figure 7-4. SDO_CNTL1 Register

7	6	5	4	3	2	1	0
0	OUTDATA_uC_MODE	DATA_RIGHT_ALIGNED	BYTE_INTERLEAVE	0	SDO_WIDTH	SDO_MODE[1:0]	
R-0b	R/W-0b	R/W-0b	R/W-0b	R-0b	R/W-0b	R/W-00b	

Table 7-6. SDO_CNTL1 Register Field Descriptions

Bit	Field	Type	Reset	Description
7	0	R	0b	Reserved bit. Do not write. Read returns 0b.
6	OUTDATA_uC_MODE	R/W	0b	Enables the MCU or processor-friendly data interface. 0b = Length of output data is determined by the DATA_OUT_FORMAT field in the DATA_CNTL register. 1b = Length of output data is fixed to 16-bits when the length based on DATA_OUT_FORMAT is ≤ 16 or 32-bits when the length based on DATA_OUT_FORMAT is > 16.
5	DATA_RIGHT_ALIGNED	R/W	0b	This bit is ignored if OUTDATA_uC_MODE = 0b. When OUTDATA_uC_MODE = 1b: 0b = Data frame is left aligned. The SDOs output the device data bits followed by 0s in a 32-bit output frame. 1b = Data frame is right aligned. The SDOs output 0s followed by device data bits in a 32-bit output frame.
4	BYTE_INTERLEAVE	R/W	0b	This bit is ignored if OUTDATA_uC_MODE = 0b or SDO_WIDTH = 0b. When OUTDATA_uC_MODE = 1b and SDO_WIDTH = 1b: 0b = Bit mode. SDO-1 outputs (MSB, MSB - 2 ..., LSB + 1) and SDO-0 outputs (MSB - 1, MSB - 3, ..., LSB). 1b = Byte mode. If the total number of bits to be read from the device is N (conversion result, parity, channel ID, and so forth) then SDO-1 outputs 8 MSB bits and SDO-0 outputs (N-8) bits when N ≤ 16 and SDO-1 outputs 16 MSB bits and SDO-0 outputs (N-16) bits when 16 < N ≤ 32.
3	0	R	0b	Reserved bit. Do not write. Read returns 0b.
2	SDO_WIDTH	R/W	0b	This bit sets the width of the output bus. 0b = Data bits are output only on SDO-0 1b = Data bits are output on SDO-0 (MSB - 1, MSB - 3 ..., LSB) and SDO-1 (MSB, MSB - 2 ..., LSB + 1)
1-0	SDO_MODE[1:0]	R/W	00b	These bits select the protocol for reading data from the device. 00b = SDO follows the SPI protocol selected in the SDI_CNTL register 01b = Invalid configuration, not supported by the device 10b = Invalid configuration, not supported by the device 11b = SDO follows the Clock Re-Timer Data Transfer section

7.1.5 SDO_CNTL2 Register (address = 0Dh) [reset = 00h]

This register configures the output data rates, SDR or DDR, when using the clock re-timer data transfer. Write access to this register is disabled on power-up. To enable write access, configure the [REG_ACCESS](#) register.

Figure 7-5. SDO_CNTL2 Register

7	6	5	4	3	2	1	0
0	0	0	0	0	0	0	DATA_RATE
R-0b	R-0b	R-0b	R-0b	R-0b	R-0b	R-0b	R/W-0b

Table 7-7. SDO_CNTL2 Register Field Descriptions

Bit	Field	Type	Reset	Description
7-1	000 0000	R	000 0000b	Reserved bit. Do not write. Reads return 000 0000b.
0	DATA_RATE	R/W	0b	This bit is ignored if SDO_MODE[1:0] = 0xb. When SDO_MODE[1:0] = 11b: 0b = SDOs are updated at a single data rate (SDR) with respect to the output clock 1b = SDOs are updated at double data rate (DDR) with respect to the output clock

7.1.6 SDO_CNTL3 Register (address = 0Eh) [reset = 00h]

The bits in this register are reserved.

Figure 7-6. SDO_CNTL3 Register

7	6	5	4	3	2	1	0
0	0	0	0	0	0	0	0
R-0b	R-0b	R-0b	R-0b	R-0b	R-0b	R-0b	R-0b

Table 7-8. SDO_CNTL3 Register Field Descriptions

Bit	Field	Type	Reset	Description
7-0	0000 0000	R	0000 0000b	Reserved bits. Do not write. Reads return 0000 0000b.

7.1.7 SDO_CNTL4 Register (address = 0Fh) [reset = 00h]

This register configures the behavior of the SEQ_STS pin when not using dual SDO mode (SDO_WIDTH = 0b). Write access to this register is disabled on power-up. To enable write access, configure the [REG_ACCESS](#) register.

Figure 7-7. SDO_CNTL4 Register

7	6	5	4	3	2	1	0
0	0	0	0	0	0	0	SEQSTS_CFG
R-0b	R-0b	R-0b	R-0b	R-0b	R-0b	R-0b	R/W-0b

Table 7-9. SDO_CNTL4 Register Field Descriptions

Bit	Field	Type	Reset	Description
7-1	000 0000	R	000 0000b	Reserved bits. Do not write. Reads return 000 0000b.
0	SEQSTS_CFG	R/W	0b	This pin decides the behavior of SDO-1 when SDO_WIDTH = 0b. 0b = SDO-1 is Hi-Z 1b = SDO-1 indicates the sequence of the active status

7.1.8 DATA_CNTL Register (address = 10h) [reset = 00h]

This register configures the contents of the output data word. Write access to this register is disabled on power-up. To enable write access, configure the [REG_ACCESS](#) register.

Figure 7-8. DATA_CNTL Register

7	6	5	4	3	2	1	0
0	0	DATA_OUT_FORMAT[1:0]		0	0	0	DATA_VAL
R-0b	R-0b	R/W-00b		R-0b	R-0b	R-0b	R/W-0b

Table 7-10. DATA_CNTL Register Field Descriptions

Bit	Field	Type	Reset	Description
7-6	00	R	000b	Reserved bits. Reads return 00b.
5-4	DATA_OUT_FORMAT[1:0]	R/W	00b	These bits control the composition of the output data frame. 00b = ADC conversion result 01b = ADC conversion result + 4-bit channel ID 10b = ADC conversion result + 4-bit channel ID + 4-bit device status (see Table 7-24) + 2-bit channel configuration 11b = Reserved Parity bits are appended to the data output frame. See the PARITY_CNTL register for details.
3-1	000	R	000b	Reserved bits. Reads return 00b.
0	DATA_VAL	R/W	0b	Setting this bit enables debug mode for SDO capture. 0b = Normal operation; device data are output on SDO 1b = The device outputs a fixed xA5A5 patten that is useful for debugging data capture from the device

7.1.9 PARITY_CNTL Register (address = 11h) [reset = 00h]

This register enables or disables the computing parity status for the output from the device. Write access to this register is disabled on power-up. To enable write access, configure the [REG_ACCESS](#) register.

Figure 7-9. PARITY_CNTL Register

7	6	5	4	3	2	1	0
0	0	0	0	0	PARITY_EN	0	0
R-0b	R-0b	R-0b	R-0b	R-0b	R/W-0b	R-0b	R-0b

Table 7-11. PARITY_CNTL Register Field Descriptions

Bit	Field	Type	Reset	Description
7-3	0 0000	R	0 0000b	Reserved bits. Do not write. Reads return 0 0000b.
2	PARITY_EN	R/W	0b	Enables the parity computation on the data output bits. The value of the parity bit is 1 if the data output frame contains an odd number of 1s. 0b = Parity disabled 1b = A 1-bit parity is appended to the data output frame. Data length is 1-bit more than the length specified by DATA_OUT_FORMAT in the DATA_CNTL register.
1-0	00	R	00b	Reserved bits. Do not write. Reads return 00b.

7.2 Device Calibration Registers

Table 7-12 maps the device features following register calibration.

Table 7-12. Calibration Registers Mapping

ADDRESS	REGISTER NAME	REGISTER DESCRIPTION
18h	OFST_CAL	Setting for optimum ADC offset calibration when using an external reference input
19h	REF_MRG1	Margin setting for the reference buffer to compensate for initial accuracy of the reference voltage
1Ah	REF_MRG2	Enable margin setting of the reference buffer as configured in the REF_MRG1 register
1Bh	REFby2_MRG	REFby2 buffer margin configuration

7.2.1 OFST_CAL Register (address = 18h) [reset = 00h]

This register selects the optimal offset calibration when using an external reference input. When using an internal reference, do not write to this register. See the [Reference](#) section for more details.

Figure 7-10. OFST_CAL Register

7	6	5	4	3	2	1	0
0	0	0	0	0	REF_SEL[2:0]		
R-0b	R-0b	R-0b	R-0b	R-0b	R/W-000b		

Table 7-13. OFST_CAL Register Field Descriptions

Bit	Field	Type	Reset	Description
7-3	0	R	0 0000b	Reserved bits. Reads return 0 0000b.
2-0	REF_SEL[2:0]	R/W	000b	These bits select the external reference range for optimal offset. 000b = Optimum offset calibration for $V_{REF} = 5.0V$ 001b = Optimum offset calibration for $V_{REF} = 4.5V$ 010b = Optimum offset calibration for $V_{REF} = 4.096V$ 011b = Optimum offset calibration for $V_{REF} = 3.3V$ 100b = Optimum offset calibration for $V_{REF} = 3.0V$ 101b = Optimum offset calibration for $V_{REF} = 2.5V$ 110b = Optimum offset calibration for $V_{REF} = 5.0V$ 111b = Optimum offset calibration for $V_{REF} = 5.0V$

7.2.2 REF_MRG1 Register (address = 19h) [reset = 00h]

This register selects the margining to be added to or subtracted from the reference buffer output; see the [Reference](#) section.

Figure 7-11. REF_MRG1 Register

7	6	5	4	3	2	1	0
0	0	0	REF_OFST[4:0]				
R-0b	R-0b	R-0b	R/W-00000b				

Table 7-14. REF_MRG1 Register Field Descriptions

Bit	Field	Type	Reset	Description
7-5	0	R	000b	Reserved bits. Reads return 000b.
4-0	REF_OFST[4:0]	R/W	00000b	These bits select the reference offset value as per Table 7-15 .

Table 7-15. REF_OFST[4:0] Settings

REF_OFST[4:0]	$\Delta V_{REFBUFOUT}^{(1)}$	REF_OFST[4:0]	$\Delta V_{REFBUFOUT}^{(1)}$
00000b	0mV	10000b	-4.5mV
00001b	280 μ V	10001b	-4.22mV
00010b	580 μ V	10010b	-3.94mV
00011b	840 μ V	10011b	-3.66mV
00100b	1.12mV	10100b	-3.38mV
00101b	1.4mV	10101b	-3.1mV
00110b	1.68mV	10110b	-2.82mV
00111b	1.96mV	10111b	-2.54mV
01000b	2.24mV	11000b	-2.26mV
01001b	2.52mV	11001b	-1.98mV
01010b	2.8mV	11010b	-1.70mV
01011b	3.08mV	11011b	-1.42mV
01100b	3.36mV	11100b	-1.14mV
01101b	3.64mV	11101b	-860 μ V
01110b	3.92mV	11110b	-580 μ V
01111b	4.2mV	11111b	-280 μ V

(1) The actual $V_{REFBUFOUT}$ value may vary by $\pm 10\%$ from [Table 7-15](#).

7.2.3 REF_MRG2 Register (address = 1Ah) [reset = 00h]

This register enables or disables the reference buffer margin configuration in the [REF_MRG1](#) register.

Figure 7-12. REF_MRG2 Register

7	6	5	4	3	2	1	0
0	0	0	0	0	0	0	EN_MARG
R-0b	R-0b	R-0b	R-0b	R-0b	R-0b	R-0b	R/W-0b

Table 7-16. REF_MRG2 Register Field Descriptions

Bit	Field	Type	Reset	Description
7-1	0	R	000 0000b	Reserved bits. Reads return 000 0000b.
0	EN_MARG	R/W	0b	This bit enables the reference buffer margining feature. 0b = Margining is disabled 1b = Margining is enabled

7.2.4 REFby2_MRG Register (address = 1Bh) [reset = 00h]

This register selects the margining to be added to or subtracted from the REFFby2 buffer output; see the [REFby2 Buffer](#) section.

Figure 7-13. REFby2_MRG Register

7	6	5	4	3	2	1	0
0	REFby2_OFST[2:0]			0	0	0	EN_REFby2_MARG
R-0b	R/W-000b			R-0b	R-0b	R-0b	R/W-0b

Table 7-17. REFby2_MRG Register Field Descriptions

Bit	Field	Type	Reset	Description
7	0	R	0b	Reserved bit. Do not write. Reads return 0b.
6-4	REFBY2_OFST[2:0]	R/W	000b	These bits select the REFby2 offset value as per Table 7-18 .
3-1	0	R	000b	Reserved bits. Do not write. Reads return 000b.
0	EN_REFby2_MARG	R/W	0b	This bit enables the REFby2 buffer margining feature. 0b = Margining is disabled 1b = Margining is enabled

Table 7-18. REFby2_OFST[2:0] Settings

REFby2_OFST[2:0]	$V_{REFby2}^{(1)}$ ($V_{REF} = 4.096V$)	$V_{REFby2}^{(1)}$ ($V_{REF} = 5V$)
EN_REFby2_MARG = 0b	2.04800V	2.50000V
000b	2.12611V	2.59155V
001b	2.13008V	2.59640V
010b	2.13406V	2.60124V
011b	2.13804V	2.60610V
100b	2.14203V	2.61096V
101b	2.14602V	2.61581V
110b	2.14999V	2.62065V
111b	2.15397V	2.62550V

(1) The offset in nominal V_{REFby2} value potentially varies by $\pm 10\%$ from [Table 7-18](#).

7.3 Analog Input Configuration Registers

Table 7-19 maps the device features following channel configuration of the registers.

Table 7-19. Analog Input Configuration Registers Mapping

ADDRESS	REGISTER NAME	REGISTER DESCRIPTION
24h	AIN_CFG	Analog input signal configuration selection
27h	COM_CFG	AIN-COM pin configuration

7.3.1 AIN_CFG Register (address = 24h) [reset = 00h]

This register configures the analog inputs as single-ended or pseudo-differential with or without a common input.

Figure 7-14. AIN_CFG Register

7	6	5	4	3	2	1	0
CH7_CH6_CFG[1:0]		CH5_CH4_CFG[1:0]		CH3_CH2_CFG[1:0]		CH1_CH0_CFG[1:0]	
R/W-00b		R/W-00b		R/W-00b		R/W-00b	

Table 7-20. AIN_CFG Register Field Descriptions

Bit	Field	Type	Reset	Description
7-6	CH1_CH0_CFG[1:0]	R/W	00b	00b = AIN0 and AIN1 are two separate channels. The MUXOUT-M pin is connected to the AIN-COM pin. See the COM_CFG register for selecting single-ended or pseudo-differential operation. 01b = AIN0 and AIN1 are a single-ended pair. AIN0 connects to MUXOUT-P and AIN1 connects to MUXOUT-M. 10b = AIN0 and AIN1 are a pseudo-differential pair. AIN0 connects to MUXOUT-P and AIN1 connects to MUXOUT-M. 11b = Same as 00b
5-4	CH3_CH2_CFG[1:0]	R/W	00b	00b = AIN2 and AIN3 are two separate channels. The MUXOUT-M pin is connected to the AIN-COM pin. See the COM_CFG register for selecting single-ended or pseudo-differential operation. 01b = AIN2 and AIN3 are a single-ended pair. AIN2 connects to MUXOUT-P and AIN3 connects to MUXOUT-M. 10b = AIN2 and AIN3 are a pseudo-differential pair. AIN2 connects to MUXOUT-P and AIN3 connects to MUXOUT-M. 11b = Same as 00b
3-2	CH5_CH4_CFG[1:0]	R/W	00b	00b = AIN4 and AIN5 are two separate channels. The MUXOUT-M pin is connected to the AIN-COM pin. See the COM_CFG register for selecting single-ended or pseudo-differential operation. 01b = AIN4 and AIN5 are a single-ended pair. AIN4 connects to MUXOUT-P and AIN5 connects to MUXOUT-M. 10b = AIN4 and AIN5 are a pseudo-differential pair. AIN4 connects to MUXOUT-P and AIN5 connects to MUXOUT-M. 11b = Same as 00b
1-0	CH7_CH6_CFG[1:0]	R/W	00b	00b = AIN6 and AIN7 are two separate channels. MUXOUT-M pin connected to AIN-COM pin. See the COM_CFG register for selecting single-ended or pseudo-differential operation. 01b = AIN6 and AIN7 are a single-ended pair. AIN6 connects to MUXOUT-P and AIN7 connects to MUXOUT-M. 10b = AIN6 and AIN7 are a pseudo-differential pair. AIN6 connects to MUXOUT-P and AIN7 connects to MUXOUT-M. 11b = Same as 00b

7.3.2 COM_CFG Register (address = 27h) [reset = 00h]

This register selects single-ended or pseudo-differential operation for any analog input channels that are not configured as pairs (see the [AIN_CFG](#) register). Depending on the contents of this register, connect AIN-COM to either GND or REFby2 on the PCB.

Figure 7-15. COM_CFG Register

7	6	5	4	3	2	1	0
0	0	0	0	0	0	0	COM_CFG
R-0b	R-0b	R-0b	R-0b	R-0b	R-0b	R-0b	R/W-0b

Table 7-21. COM_CFG Register Field Descriptions

Bit	Field	Type	Reset	Description
7-1	0	R	000 0000b	Reserved bits. Reads return 000 0000b.
0	COM_CFG	R/W	0b	This bit selects the analog input channel configuration when = 00b or 11b in the AIN_CFG register: 0b = All individual channels are single-ended inputs; connect the AIN-COM pin to GND 1b = All individual channels are pseudo-differential inputs; connect the AIN-COM pin to REFby2

7.4 Channel Sequence Configuration Registers Map

Table 7-22 maps the device features following channel configuration of the registers.

Table 7-22. Channel Sequence Configuration Registers Mapping

ADDRESS	REGISTER NAME	REGISTER DESCRIPTION
1Ch	DEVICE_CFG	MUX sequence configuration and device status bits
1Dh	CHANNEL_ID	Analog input channel selection in manual mode (see the <i>Manual Mode</i> section)
1Eh	SEQ_START	Control for starting the multiplexer sequence
1Fh	SEQ_STOP	Control for aborting the multiplexer sequence
2Ah	ON_THE_FLY_CFG	Enables or disables on-the-fly mode (see the <i>On-The-Fly Mode</i> section)
80h	AUTO_SEQ_CFG1	Channel selection register for auto sequence mode (see the <i>Auto Sequence Mode</i> section)
82h	AUTO_SEQ_CFG2	Control for repeating the channels in auto sequence mode

7.4.1 DEVICE_CFG Register (address = 1Ch) [reset = 00h]

This register selects the mode of channel sequencing and reading this register returns device status information.

Figure 7-16. DEVICE_CFG Register

7	6	5	4	3	2	1	0
0	0	0	0	ALERT_STATUS	ERROR_STATUS	SEQ_MODE[1:0]	
R-0b	R-0b	R-0b	R-0b	R-0b	R-0b	R/W-00b	

Table 7-23. DEVICE_CFG Register Field Descriptions

Bit	Field	Type	Reset	Description
7-4	0	R	0000b	Reserved bits. Do not write. Reads return 0000b.
3	ALERT_STATUS	R	0b	Read only. This bit reflects the ALERT pin logic level.
2	ERROR_STATUS	R	0b	Read only. This bit indicates a device configuration error: 0b = No error 1b = Error in configuration
1-0	SEQ_MODE[1:0]	R/W	00b	Sets the MUX channel selection operation: 00b = Manual mode 01b = On-the-fly mode 10b = Auto sequence mode 11b = Custom channel sequencing mode (see the <i>Custom Channel Sequencing Mode</i> section)

Table 7-24 describes how the ALERT_STATUS, ERROR_STATUS, and SEQ_MODE[1:0] bits are collectively decoded to indicate events.

Table 7-24. Decoding the DEVICE_CFG Read Value

ALERT_STATUS	ERROR_STATUS	SEQ_MODE[1:0]	EVENT DESCRIPTION
0	0	00	No ALERT, no error, manual mode
0	0	01	No ALERT, no error, on-the-fly mode
0	0	10	No ALERT, no error, auto sequence mode
0	0	11	No ALERT, no error, custom channel sequencing mode
0	1	00	No ALERT, error, manual mode
0	1	01	No ALERT, error, on-the-fly mode
0	1	10	No ALERT, error, auto sequence mode
0	1	11	No ALERT, error, custom channel sequencing mode
1	0	00	ALERT, no error, manual mode
1	0	01	ALERT, no error, on-the-fly mode
1	0	10	ALERT, no error, auto sequence mode
1	0	11	ALERT, no error, custom channel sequencing mode
1	1	00	ALERT, error, manual mode
1	1	01	ALERT, error, on-the-fly mode
1	1	10	ALERT, error, auto sequence mode
1	1	11	ALERT, error, custom channel sequencing mode

7.4.2 CHANNEL_ID Register (address = 1Dh) [reset = 00h]

This register selects the analog input channel; see the [Manual Mode](#) section.

Figure 7-17. CHANNEL_ID Register

7	6	5	4	3	2	1	0
0	0	0	0	0	CHANNEL_ID[2:0]		
R-0b	R-0b	R-0b	R-0b	R-0b	R/W-000b		

Table 7-25. CHANNEL_ID Register Field Descriptions

Bit	Field	Type	Reset	Description
7-3	0	R	0 0000b	Reserved bits. Reads return 0 0000b.
2-0	CHANNEL_ID[2:0]	R/W	000b	These bits select the analog input channel as per Table 7-26 .

Table 7-26. Analog Input Channel Selection Settings

CHANNEL_ID[2:0]	ANALOG INPUT SELECTED
000b	AIN0
001b	AIN1
010b	AIN2
011b	AIN3
100b	AIN4
101b	AIN5
110b	AIN6
111b	AIN7

Note

Writing to the [CHANNEL_ID](#) register when the device is actively operating in auto sequence mode or custom channel sequencing mode aborts the on-going sequence and the [DEVICE_CFG](#) register is set to manual mode.

7.4.3 SEQ_START Register (address = 1Eh) [reset = 00h]

This register starts the channel selection sequence when in auto sequence mode or custom channel sequencing mode. Writing to this register has no effect when in manual mode or on-the-fly mode.

Figure 7-18. SEQ_START Register

7	6	5	4	3	2	1	0
0	0	0	0	0	0	0	SEQ_START
R-0b	R-0b	R-0b	R-0b	R-0b	R-0b	R-0b	W-0b

Table 7-27. SEQ_START Register Field Descriptions

Bit	Field	Type	Reset	Description
7-1	0	R	0b	Reserved bits. Do not write.
0	SEQ_START	W	0b	This bit starts the channel scanning sequence when SEQ_MODE[1:0] = auto sequence mode or custom channel sequencing mode. 0b = No effect; any on-going sequence is not stopped 1b = Start channel sequence

7.4.4 SEQ_ABORT Register (address = 1Fh) [reset = 00h]

This register stops the channel selection sequence when in auto channel sequence mode or custom channel sequencing mode. Writing to this register has no effect when in manual mode or on-the-fly mode.

Figure 7-19. SEQ_ABORT Register

7	6	5	4	3	2	1	0
0	0	0	0	0	0	0	SEQ_ABORT
R-0b	R-0b	R-0b	R-0b	R-0b	R-0b	R-0b	W-0b

Table 7-28. SEQ_ABORT Register Field Descriptions

Bit	Field	Type	Reset	Description
7-1	0	R	0b	Reserved bits. Do not write.
0	SEQ_ABORT	W	0b	This bit stops the channel scanning sequence when SEQ_MODE[1:0] = auto sequence mode or custom channel sequencing mode. 0b = No effect 1b = Stop channel sequence

7.4.5 ON_THE_FLY_CFG Register (address = 2Ah) [reset = 00h]

This register enables on-the-fly mode of operation. This mode of operation helps select analog input channels without having to write to device configuration registers.

Figure 7-20. ON_THE_FLY_CFG Register

7	6	5	4	3	2	1	0
0	0	0	0	0	0	0	EN_ON_THE_FLY
R-0b	R-0b	R-0b	R-0b	R-0b	R-0b	R-0b	R/W-0b

Table 7-29. ON_THE_FLY_CFG Register Field Descriptions

Bit	Field	Type	Reset	Description
7-1	0	R	000 0000b	Reserved bits. Reads return 000 0000b.
0	EN_ON_THE_FLY	R/W	0b	This bit enables on-the-fly mode. 0b = On-the-fly mode disabled 1b = On-the-fly mode enabled; the first five bits on SDI select the analog input channel for next conversion (see Figure 6-13)

7.4.6 AUTO_SEQ_CFG1 Register (address = 80h) [reset = 00h]

This register selects the channels enabled for auto sequence mode.

Figure 7-21. AUTO_SEQ_CFG1 Register

7	6	5	4	3	2	1	0
EN_AIN7	EN_AIN6	EN_AIN5	EN_AIN4	EN_AIN3	EN_AIN2	EN_AIN1	EN_AIN0
R/W-0b	R/W-0b	R/W-0b	R/W-0b	R/W-0b	R/W-0b	R/W-0b	R/W-0b

Table 7-30. AUTO_SEQ_CFG1 Register Field Descriptions

Bit	Field	Type	Reset	Description
7	EN_AIN7	R/W	0b	This bit enables analog input channel 7 in the auto channel sequence mode; see the Auto Sequence Mode section. 0b = AIN7 is not enabled in the scanning sequence 1b = AIN7 is enabled in the scanning sequence
6	EN_AIN6	R/W	0b	This bit enables analog input channel 6 in the auto sequence mode. 0b = AIN6 is not enabled in the scanning sequence 1b = AIN6 is enabled in the scanning sequence
5	EN_AIN5	R/W	0b	This bit enables analog input channel 5 in the auto sequence mode. 0b = AIN5 is not enabled in the scanning sequence 1b = AIN5 is enabled in the scanning sequence
4	EN_AIN4	R/W	0b	This bit enables analog input channel 4 in the auto sequence mode. 0b = AIN4 is not enabled in the scanning sequence 1b = AIN4 is enabled in the scanning sequence
3	EN_AIN3	R/W	0b	This bit enables analog input channel 3 in the auto sequence mode. 0b = AIN3 is not enabled in the scanning sequence 1b = AIN3 is enabled in the scanning sequence
2	EN_AIN2	R/W	0b	This bit enables analog input channel 2 in the auto sequence mode. 0b = AIN2 is not enabled in the scanning sequence 1b = AIN2 is enabled in the scanning sequence
1	EN_AIN1	R/W	0b	This bit enables analog input channel 1 in the auto sequence mode. 0b = AIN1 is not enabled in the scanning sequence 1b = AIN1 is enabled in the scanning sequence
0	EN_AIN0	R/W	0b	This bit enables analog input channel 0 in the auto sequence mode. 0b = AIN0 is not enabled in the scanning sequence 1b = AIN0 is enabled in the scanning sequence

7.4.7 AUTO_SEQ_CFG2 Register (address = 82h) [reset = 00h]

This register enables the sequence loop for auto sequence mode.

Figure 7-22. AUTO_SEQ_CFG2 Register

7	6	5	4	3	2	1	0
0	0	0	0	0	0	0	AUTO_REPEAT
R-0b	R-0b	R-0b	R-0b	R-0b	R-0b	R-0b	R/W-0b

Table 7-31. AUTO_SEQ_CFG2 Register Field Descriptions

Bit	Field	Type	Reset	Description
7-1	0	R	000 0000b	Reserved bits. Reads return 000 0000b.
0	AUTO_REPEAT	R/W	0b	This bit enables looping the sequence indefinitely in auto sequence mode. 0b = Sequence terminates after all enabled channels are scanned 1b = Sequence repeats after scanning all enabled channels

7.4.8 Custom Channel Sequencing Mode Registers

Table 7-12 maps the device features for the custom channel sequencing mode registers; see the [Custom Channel Sequencing Mode](#) section for mode details.

Table 7-32. Custom Channel Sequencing Registers

ADDRESS	REGISTER NAME	REGISTER DESCRIPTION
88h	CCS_START_INDEX	Start index for the custom channel sequencing mode sequence
89h	CCS_END_INDEX	End index for the custom channel sequencing mode sequence
8Ah	CCS_SEQ_LOOP	Custom channel sequencing mode loop control
8Ch	CCS_CHID_INDEX_0	Channel ID configuration register index 0
8Dh	REPEAT_INDEX_0	Repeat count register index 0
8Eh	CCS_CHID_INDEX_1	Channel ID configuration register index 1
8Fh	REPEAT_INDEX_1	Repeat count register index 1
90h	CCS_CHID_INDEX_2	Channel ID configuration register index 2
91h	REPEAT_INDEX_2	Repeat count register index 2
92h	CCS_CHID_INDEX_3	Channel ID configuration register index 3
93h	REPEAT_INDEX_3	Repeat count register index 3
94h	CCS_CHID_INDEX_4	Channel ID configuration register index 4
95h	REPEAT_INDEX_4	Repeat count register index 4
96h	CCS_CHID_INDEX_5	Channel ID configuration register index 5
97h	REPEAT_INDEX_5	Repeat count register index 5
98h	CCS_CHID_INDEX_6	Channel ID configuration register index 6
99h	REPEAT_INDEX_6	Repeat count register index 6
9Ah	CCS_CHID_INDEX_7	Channel ID configuration register index 7
9Bh	REPEAT_INDEX_7	Repeat count register index 7
9Ch	CCS_CHID_INDEX_8	Channel ID configuration register index 8
9Dh	REPEAT_INDEX_8	Repeat count register index 8
9Eh	CCS_CHID_INDEX_9	Channel ID configuration register index 9
9Fh	REPEAT_INDEX_9	Repeat count register index 9
A0h	CCS_CHID_INDEX_10	Channel ID configuration register index 10
A1h	REPEAT_INDEX_10	Repeat count register index 10
A2h	CCS_CHID_INDEX_11	Channel ID configuration register index 11
A3h	REPEAT_INDEX_11	Repeat count register index 11
A4h	CCS_CHID_INDEX_12	Channel ID configuration register index 12
A5h	REPEAT_INDEX_12	Repeat count register index 12
A6h	CCS_CHID_INDEX_13	Channel ID configuration register index 13
A7h	REPEAT_INDEX_13	Repeat count register index 13
A8h	CCS_CHID_INDEX_14	Channel ID configuration register index 14
A9h	REPEAT_INDEX_14	Repeat count register index 14
AAh	CCS_CHID_INDEX_15	Channel ID configuration register index 15
ABh	REPEAT_INDEX_15	Repeat count register index 15

7.4.8.1 CCS_START_INDEX Register (address = 88h) [reset = 00h]

This register sets the relative sequence index where the custom channel sequencing mode starts execution from.

Figure 7-23. CCS_START_INDEX Register

7	6	5	4	3	2	1	0
0	0	0	0	SEQ_START_INDEX[3:0]			
R-0b	R-0b	R-0b	R-0b	R/W-0000b			

Table 7-33. CCS_START_INDEX Register Field Descriptions

Bit	Field	Type	Reset	Description
7-4	0	R	0000b	Reserved bits. Reads return 0000b.
3-0	SEQ_START_INDEX[3:0]	R/W	0000b	Relative pointer to the index for the start of the sequence in custom channel sequencing mode.

7.4.8.2 CCS_END_INDEX Register (address = 89h) [reset = 00h]

This register sets the relative sequence index where the custom channel sequencing mode stops execution at. Make sure the value in the [CCS_END_INDEX](#) register is not less than the value in the [CCS_START_INDEX](#) register.

Figure 7-24. CCS_END_INDEX Register

7	6	5	4	3	2	1	0
0	0	0	0	SEQ_END_INDEX[3:0]			
R-0b	R-0b	R-0b	R-0b	R/W-0000b			

Table 7-34. CCS_END_INDEX Register Field Descriptions

Bit	Field	Type	Reset	Description
7-4	0	R	0000b	Reserved bits. Reads return 0000b.
3-0	SEQ_END_INDEX[3:0]	R/W	0000b	Relative pointer to the index for the end of the sequence in custom channel sequencing mode.

7.4.8.3 CCS_SEQ_LOOP Register (address = 8Ah) [reset = 00h]

This register controls the looping of the sequence in custom channel sequencing mode.

Figure 7-25. CCS_SEQ_LOOP Register

7	6	5	4	3	2	1	0
0	0	0	0	0	0	0	SEQ_LOOP
R-0b	R-0b	R-0b	R-0b	R-0b	R-0b	R-0b	R/W-0b

Table 7-35. CCS_SEQ_LOOP Register Field Descriptions

Bit	Field	Type	Reset	Description
7-1	0	R	000 0000b	Reserved bits. Reads return 000 0000b.
0	SEQ_LOOP	R/W	0b	Configures the looping of sequence in custom channel sequencing mode. 0b = Sequence ends at the index location configured in the CCS_END_INDEX [3:0] bits; see the CCS_END_INDEX register 1b = Sequence resumes from the CCS_START_INDEX [3:0] bits (see the CCS_START_INDEX register) after executing the CCS_END_INDEX [3:0] bits.

7.4.8.4 CCS_CHID_INDEX_m Registers (address = 8C, 8E, 90, 92, 94, 96, 98, 9A, 9C, 9E, A0, A2, A4, A6, A8, and AAh) [reset = 00h]

In custom channel sequencing mode, the intended sequence of the analog input channels is programmed in these 16 registers. See the [REPEAT_INDEX_m](#) registers for details about repeating a particular channel before switching to the next index.

Figure 7-26. CCS_CHID_INDEX_m Register

7	6	5	4	3	2	1	0
0	0	0	0	0	CHID[2:0]		
R-0b	R-0b	R-0b	R-0b	R-0b	R/W-000b		

Table 7-36. CCS_CHID_INDEX_m Register Field Descriptions

Bit	Field	Type	Reset	Description
7-3	0	R	0 0000b	Reserved bits. Reads return 0 0000b.
2-0	CHID[2:0]	R/W	000b	These bits configure the analog input channel associated with the index in custom channel sequencing mode. 000b = AIN0 001b = AIN1 010b = AIN2 011b = AIN3 100b = AIN4 101b = AIN5 110b = AIN6 111b = AIN7

7.4.8.5 REPEAT_INDEX_m Registers (address = 8D, 8F, 91, 93, 95, 97, 99, 9B, 9D, 9F, A1, A3, A5, A7, A9, and ABh) [reset = 00h]

In custom channel sequencing mode, the analog input selected in the corresponding [CCS_CHID_INDEX](#) register is repeated by configuring the respective register.

Figure 7-27. REPEAT_INDEX_m Register

7	6	5	4	3	2	1	0
REPEAT[7:0]							
R/W-1111 1111b							

Table 7-37. REPEAT_INDEX_m Register Field Descriptions

Bit	Field	Type	Reset	Description
7-0	REPEAT[7:0]	R/W	1111 1111b	These bits configure the number of times the analog input configured in the corresponding CCS_CHID_INDEX register is repeated. Configuring 0000 0000b in this register results in an error.

7.5 Digital Window Comparator Configuration Registers Map

Table 7-38 maps the device features for the digital window comparator; see the [Digital Window Comparator](#) section.

Table 7-38. Digital Window Comparator Configuration Registers Mapping

ADDRESS	REGISTER NAME	REGISTER DESCRIPTION
2Eh	ALERT_CFG	ALERT enable control for individual analog input channels
31h and 30h	HI_TRIG_AIN7	High threshold input for the AIN7 digital window comparator
35h and 34h	HI_TRIG_AIN6	High threshold input for the AIN6 digital window comparator
39h and 38h	HI_TRIG_AIN5	High threshold input for AIN5 digital window comparator
3Dh and 3Ch	HI_TRIG_AIN4	High threshold input for the AIN4 digital window comparator
41h and 40h	HI_TRIG_AIN3	High threshold input for the AIN3 digital window comparator
45h and 44h	HI_TRIG_AIN2	High threshold input for the AIN2 digital window comparator
49h and 48h	HI_TRIG_AIN1	High threshold input for the AIN1 digital window comparator
4Dh and 4Ch	HI_TRIG_AIN0	High threshold input for the AIN0 digital window comparator
55h and 54h	LO_TRIG_AIN7	Low threshold input for the AIN7 digital window comparator
59h and 58h	LO_TRIG_AIN6	Low threshold input for the AIN6 digital window comparator
5Dh and 5Ch	LO_TRIG_AIN5	Low threshold input for the AIN5 digital window comparator
61h and 60h	LO_TRIG_AIN4	Low threshold input for the AIN4 digital window comparator
65h and 64h	LO_TRIG_AIN3	Low threshold input for the AIN3 digital window comparator
69h and 68h	LO_TRIG_AIN2	Low threshold input for the AIN2 digital window comparator
6Dh and 6Ch	LO_TRIG_AIN1	Low threshold input for the AIN1 digital window comparator
71h and 70h	LO_TRIG_AIN0	Low threshold input for the AIN0 digital window comparator
33h	HYSTERESIS_AIN7	Threshold hysteresis for the AIN7 digital window comparator
37h	HYSTERESIS_AIN6	Threshold hysteresis for the AIN6 digital window comparator
3Bh	HYSTERESIS_AIN5	Threshold hysteresis for the AIN5 digital window comparator
3Fh	HYSTERESIS_AIN4	Threshold hysteresis for the AIN4 digital window comparator
43h	HYSTERESIS_AIN3	Threshold hysteresis for the AIN3 digital window comparator
47h	HYSTERESIS_AIN2	Threshold hysteresis for the AIN2 digital window comparator
4Bh	HYSTERESIS_AIN1	Threshold hysteresis for the AIN1 digital window comparator
4Fh	HYSTERESIS_AIN0	Threshold hysteresis for the AIN0 digital window comparator
78h	ALERT_LO_STATUS	Indicates the analog input channel-wise ALERT resulting from a low threshold
79h	ALERT_HI_STATUS	Indicates the analog input channel-wise ALERT resulting from a high threshold
7Ah	ALERT_STATUS	Indicates the analog input channel-wise ALERT status
7Ch	CURR_ALERT_LO_STATUS	Indicates the analog input channel-wise ALERT resulting from a low threshold for the last conversion data
7Dh	CURR_ALERT_HI_STATUS	Indicates the analog input channel-wise ALERT resulting from a high threshold for the last conversion data
7Eh	CURR_ALERT_STATUS	Indicates the analog input channel-wise ALERT status for the last conversion data

7.5.1 ALERT_CFG Register (address = 2Eh) [reset = 00h]

This register enables or disables the digital window comparator for the individual analog input channels.

Figure 7-28. ALERT_CFG Register

7	6	5	4	3	2	1	0
ALERT_EN_AIN7	ALERT_EN_AIN6	ALERT_EN_AIN5	ALERT_EN_AIN4	ALERT_EN_AIN3	ALERT_EN_AIN2	ALERT_EN_AIN1	ALERT_EN_AIN0
R/W-0b	R/W-0b	R/W-0b	R/W-0b	R/W-0b	R/W-0b	R/W-0b	R/W-0b

Table 7-39. ALERT_CFG Register Field Descriptions

Bit	Field	Type	Reset	Description
7	ALERT_EN_AIN7	R/W	0b	Digital window comparator control for respective analog input. 0b = Digital window comparator disabled 1b = Digital window comparator enabled
6	ALERT_EN_AIN6	R/W	0b	
5	ALERT_EN_AIN5	R/W	0b	
4	ALERT_EN_AIN4	R/W	0b	
3	ALERT_EN_AIN3	R/W	0b	
2	ALERT_EN_AIN2	R/W	0b	
1	ALERT_EN_AIN1	R/W	0b	
0	ALERT_EN_AIN0	R/W	0b	

When the digital window comparator is disabled, the bits corresponding to the disabled digital window comparator are not updated in the ALERT_STATUS, ALERT_HI_STATUS, ALERT_LO_STATUS, CURR_ALERT_STATUS, CURR_ALERT_HI_STATUS, or CURR_ALERT_LO_STATUS registers.

7.5.2 HI_TRIG_AINx[15:0] Register (address = 4Dh to 30h) [reset = 0000h]

This bank of registers configures the high threshold for the digital window comparator. For 16-bit ADC data output, the comparator thresholds are 16-bits wide and are spread over two 8-bit registers. Use the registers listed in [Table 7-40](#) to configure the high threshold for the individual analog input channels.

Table 7-40. HI_TRIG_AINx[15:0] Register Address Map⁽¹⁾

ANALOG INPUT	REGISTER ADDRESS FOR HI_TRIG_AINx[15:8]	REGISTER ADDRESS FOR HI_TRIG_AINx[7:0]
AIN7	031h	030h
AIN6	035h	034h
AIN5	039h	038h
AIN4	03Dh	03Ch
AIN3	041h	040h
AIN2	045h	044h
AIN1	049h	048h
AIN0	04Dh	04Ch

(1) AINx refers to analog inputs channels AIN0, AIN1, AIN2, AIN3, AIN4, AIN5, AIN6, and AIN7.

Figure 7-29. MSB Byte Register for HI_TRIG_AINx[15:8]

7	6	5	4	3	2	1	0
HI_TRIG[15:8]							
R/W-0000 0000b							

Figure 7-30. LSB Byte Register for HI_TRIG_AINx[7:0]

7	6	5	4	3	2	1	0
HI_TRIG[7:0]							
R/W-0000 0000b							

Table 7-41. HI_TRIG_AINx[15:0] Registers Field Descriptions

Bit	Field	Type	Reset	Description
15:0	HI_TRIG[15:0]	R/W	0000 0000 0000 0000b	High threshold for the digital window comparator

7.5.3 LO_TRIG_AINx[15:0] Register (address = 71h to 54h) [reset = 0000h]

This bank of registers configures the low threshold for the digital window comparator. For 16-bit ADC data output, the comparator thresholds are 16-bits wide and are spread over two 8-bit registers. Use the registers listed in [Table 7-42](#) to configure the low threshold for the individual analog input channels

Table 7-42. LO_TRIG_AINx[15:0] Register Address Map⁽¹⁾

ANALOG INPUT	REGISTER ADDRESS FOR LO_TRIG_AINx[15:8]	REGISTER ADDRESS FOR LO_TRIG_AINx[7:0]
AIN7	051h	054h
AIN6	059h	058h
AIN5	05Dh	05Ch
AIN4	061h	060h
AIN3	065h	064h
AIN2	069h	068h
AIN1	06Dh	06Ch
AIN0	071h	070h

(1) AINx refers to analog inputs channels AIN0, AIN1, AIN2, AIN3, AIN4, AIN5, AIN6, and AIN7.

Figure 7-31. MSB Byte Register for LO_TRIG_AINx[15:8]

7	6	5	4	3	2	1	0
LO_TRIG[15:8]							
R/W-0000 0000b							

Figure 7-32. LSB Byte Register for LO_TRIG_AINx[7:0]

7	6	5	4	3	2	1	0
LO_TRIG[7:0]							
R/W-0000 0000b							

Table 7-43. LO_TRIG_AINx[15:0] Registers Field Descriptions

Bit	Field	Type	Reset	Description
15:0	LO_TRIG[15:0]	R/W	0000 0000 0000 0000b	Low threshold for the digital window comparator

7.5.4 HYSTERESIS_AINx[7:0] Register (address = 4Fh to 33h) [reset = 00h]

This bank of registers configures the hysteresis around the high and low thresholds for the digital window comparator. For 16-bit ADC data output, the hysteresis is six bits wide.

Figure 7-33. HYSTERESIS_AINx[7:0] Registers

7	6	5	4	3	2	1	0
HYSTERESIS[5:0]						0	0
R/W-00 0000b						R-0b	R-0b

Table 7-44. HYSTERESIS_AINx[7:0]⁽¹⁾ Register Field Descriptions

Bit	Field	Type	Reset	Description
7:2	HYSTERESIS[5:0]	R/W	000 0000b	Low threshold for the digital window comparator

(1) AINx refers to analog inputs channels AIN0, AIN1, AIN2, AIN3, AIN4, AIN5, AIN6, and AIN7.

7.5.5 ALERT_LO_STATUS Register (address = 78h) [reset = 00h]

This register reflects the status of the ALERT pin resulting from the low thresholds of the respective analog input channels.

Figure 7-34. ALERT_LO_STATUS Register

7	6	5	4	3	2	1	0
ALERT_LO_AIN7	ALERT_LO_AIN6	ALERT_LO_AIN5	ALERT_LO_AIN4	ALERT_LO_AIN3	ALERT_LO_AIN2	ALERT_LO_AIN1	ALERT_LO_AIN0
R/W-0b	R/W-0b	R/W-0b	R/W-0b	R/W-0b	R/W-0b	R/W-0b	R/W-0b

Table 7-45. ALERT_LO_STATUS Register Field Descriptions

Bit	Field	Type	Reset	Description
7	ALERT_LO_AIN7	R/W	0b	These bits indicate that the low threshold for the respective analog input has been exceeded. 0b = Low threshold is not exceeded 1b = Low threshold has been exceeded; clear this bit by writing 1b
6	ALERT_LO_AIN6	R/W	0b	
5	ALERT_LO_AIN5	R/W	0b	
4	ALERT_LO_AIN4	R/W	0b	
3	ALERT_LO_AIN3	R/W	0b	
2	ALERT_LO_AIN2	R/W	0b	
1	ALERT_LO_AIN1	R/W	0b	
0	ALERT_LO_AIN0	R/W	0b	

7.5.6 ALERT_HI_STATUS Register (address = 79h) [reset = 00h]

This register reflects the status of the ALERT pin resulting from the high thresholds of the respective analog input channels.

Figure 7-35. ALERT_HI_STATUS Register

7	6	5	4	3	2	1	0
ALERT_HI_AIN7	ALERT_HI_AIN6	ALERT_HI_AIN5	ALERT_HI_AIN4	ALERT_HI_AIN3	ALERT_HI_AIN2	ALERT_HI_AIN1	ALERT_HI_AIN0
R/W-0b	R/W-0b	R/W-0b	R/W-0b	R/W-0b	R/W-0b	R/W-0b	R/W-0b

Table 7-46. ALERT_HI_STATUS Register Field Descriptions

Bit	Field	Type	Reset	Description
7	ALERT_HI_AIN7	R/W	0b	These bits indicate that the high threshold for the respective analog has been exceeded. 0b = High threshold is not exceeded 1b = High threshold has been exceeded; clear this bit by writing 1b
6	ALERT_HI_AIN6	R/W	0b	
5	ALERT_HI_AIN5	R/W	0b	
4	ALERT_HI_AIN4	R/W	0b	
3	ALERT_HI_AIN3	R/W	0b	
2	ALERT_HI_AIN2	R/W	0b	
1	ALERT_HI_AIN1	R/W	0b	
0	ALERT_HI_AIN0	R/W	0b	

7.5.7 ALERT_STATUS Register (address = 7Ah) [reset = 00h]

This register reflects the ALERT status for the analog input channels.

Figure 7-36. ALERT_STATUS Register

7	6	5	4	3	2	1	0
ALERT_AIN7	ALERT_AIN6	ALERT_AIN5	ALERT_AIN4	ALERT_AIN3	ALERT_AIN2	ALERT_AIN1	ALERT_AIN0
R-0b	R-0b	R-0b	R-0b	R-0b	R-0b	R-0b	R-0b

Table 7-47. ALERT_STATUS Register Field Descriptions

Bit	Field	Type	Reset	Description
7	ALERT_AIN7	R	0b	These bits indicate if either the high or low threshold for the respective analog input has been exceeded. 0b = Neither the high or low threshold have been exceeded 1b = Either the high threshold, the low threshold, or both thresholds have been exceeded
6	ALERT_AIN6	R	0b	
5	ALERT_AIN5	R	0b	
4	ALERT_AIN4	R	0b	
3	ALERT_AIN3	R	0b	
2	ALERT_AIN2	R	0b	
1	ALERT_AIN1	R	0b	
0	ALERT_AIN0	R	0b	

If the ALERT bit for a particular channel is set in the [ALERT_STATUS](#) register, then the ALERT bit is cleared by writing 1b to the corresponding bit in the ALERT_HI_STATUS or ALERT_LO_STATUS registers. If both the high and low thresholds have been exceeded for a particular analog input channel, then make sure the corresponding ALERT bit in both the ALERT_HI_STATUS or ALERT_LO_STATUS registers is set to 1b to clear the ALERT bit.

7.5.8 CURR_ALERT_LO_STATUS Register (address = 7Ch) [reset = 00h]

This register reflects the low threshold ALERT status for the analog input channels. The bits in this register are updated after every conversion.

Figure 7-37. CURR_ALERT_LO_STATUS Register

7	6	5	4	3	2	1	0
ALERT_LO_AIN7	ALERT_LO_AIN6	ALERT_LO_AIN5	ALERT_LO_AIN4	ALERT_LO_AIN3	ALERT_LO_AIN2	ALERT_LO_AIN1	ALERT_LO_AIN0
R-0b	R-0b	R-0b	R-0b	R-0b	R-0b	R-0b	R-0b

Table 7-48. CURR_ALERT_LO_STATUS Register Field Descriptions

Bit	Field	Type	Reset	Description
7	ALERT_LO_AIN7	R	0b	These bits indicate if the low threshold for the respective analog input has been exceeded by the last conversion result from the respective analog input. 0b = Low threshold is not exceeded 1b = Low threshold has been exceeded
6	ALERT_LO_AIN6	R	0b	
5	ALERT_LO_AIN5	R	0b	
4	ALERT_LO_AIN4	R	0b	
3	ALERT_LO_AIN3	R	0b	
2	ALERT_LO_AIN2	R	0b	
1	ALERT_LO_AIN1	R	0b	
0	ALERT_LO_AIN0	R	0b	

The status of the individual bits in this register is evaluated after every conversion. The contents of this register ascertain if the last output data are within the specified high threshold for the respective analog input channels.

7.5.9 CURR_ALERT_HI_STATUS Register (address = 7Dh) [reset = 00h]

This register reflects the high threshold ALERT status for the analog input channels. The bits in this register are updated after every conversion.

Figure 7-38. CURR_ALERT_HI_STATUS Register

7	6	5	4	3	2	1	0
ALERT_HI_AIN7	ALERT_HI_AIN6	ALERT_HI_AIN5	ALERT_HI_AIN4	ALERT_HI_AIN3	ALERT_HI_AIN2	ALERT_HI_AIN1	ALERT_HI_AIN0
R/W-0b	R/W-0b	R/W-0b	R/W-0b	R/W-0b	R/W-0b	R/W-0b	R/W-0b

Table 7-49. CURR_ALERT_HI_STATUS Register Field Descriptions

Bit	Field	Type	Reset	Description
7	ALERT_HI_AIN7	R	0b	These bits indicate if the high threshold for the respective analog input has been exceeded by the last conversion result from the respective analog input. 0b = High threshold is not exceeded 1b = High threshold has been exceeded
6	ALERT_HI_AIN6	R	0b	
5	ALERT_HI_AIN5	R	0b	
4	ALERT_HI_AIN4	R	0b	
3	ALERT_HI_AIN3	R	0b	
2	ALERT_HI_AIN2	R	0b	
1	ALERT_HI_AIN1	R	0b	
0	ALERT_HI_AIN0	R	0b	

The status of the individual bits in this register is evaluated after every conversion. The contents of this register ascertain if the last output data are within the specified high threshold for the respective analog input channels.

7.5.10 CURR_ALERT_STATUS Register (address = 7Eh) [reset = 00h]

This register reflects the ALERT pin status for the analog input channels. The bits in this register are updated after every conversion.

Figure 7-39. CURR_ALERT_STATUS Register

7	6	5	4	3	2	1	0
ALERT_AIN7	ALERT_AIN6	ALERT_AIN5	ALERT_AIN4	ALERT_AIN3	ALERT_AIN2	ALERT_AIN1	ALERT_AIN0
R-0b	R-0b	R-0b	R-0b	R-0b	R-0b	R-0b	R-0b

Table 7-50. CURR_ALERT_STATUS Register Field Descriptions

Bit	Field	Type	Reset	Description
7	ALERT_AIN7	R	0b	These bits indicate that either the high or low threshold for the respective analog input has been exceeded by the last conversion result from the respective analog input. 0b = Neither the high or low threshold have been exceeded 1b = Either the high threshold, the low threshold, or both thresholds have been exceeded
6	ALERT_AIN6	R	0b	
5	ALERT_AIN5	R	0b	
4	ALERT_AIN4	R	0b	
3	ALERT_AIN3	R	0b	
2	ALERT_AIN2	R	0b	
1	ALERT_AIN1	R	0b	
0	ALERT_AIN0	R	0b	

Bits in this register reflect the result of the logical OR of the corresponding channel bits in the CURR_ALERT_HI_STATUS and CURR_ALERT_LO_STATUS registers. The status of the individual bits in this register is evaluated after every conversion. The contents of this register ascertain if the last output data are within the specified high and low thresholds for the respective analog input channels.

8 Application and Implementation

Note

Information in the following applications sections is not part of the TI component specification, and TI does not warrant its accuracy or completeness. TI's customers are responsible for determining suitability of components for their purposes, as well as validating and testing their design implementation to confirm system functionality.

8.1 Application Information

8.1.1 Multiplexer Input Connection

The ADS816x enables using a common amplifier to drive the ADC inputs as shown in [Figure 8-1](#). This configuration improves offset error mismatch between the analog inputs as the offset error of the amplifier is common to all the analog input channels.

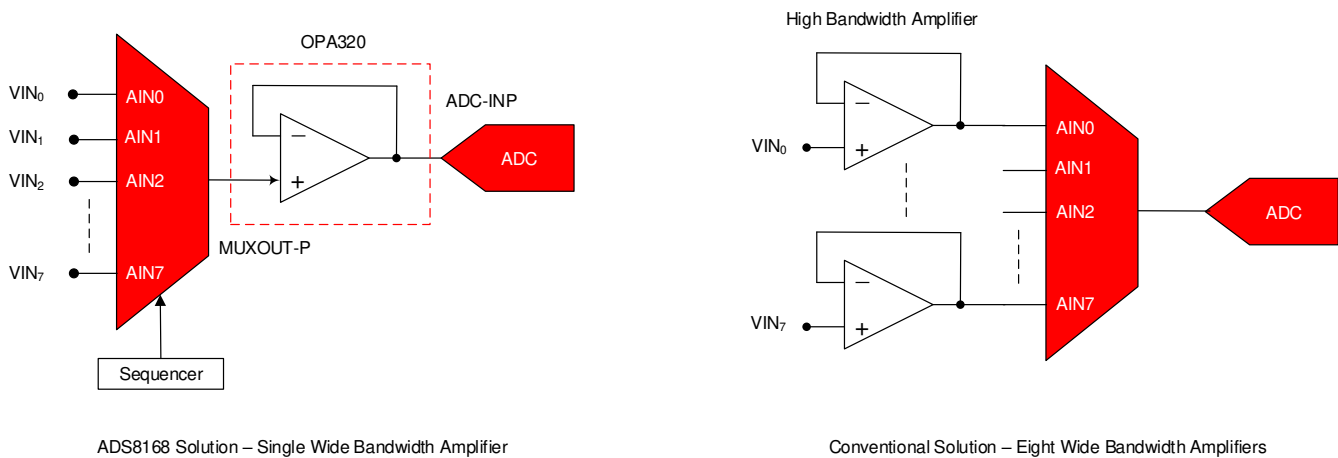

Figure 8-1. Small-Size and Low-Power 8-Channel DAQ System Using the ADS816x

When connecting the sensor directly to the input of the ADS816x, the maximum switching speed of the multiplexer is limited by multiplexer on-resistance and parasitic capacitance. [Figure 8-2](#) illustrates the source resistance (R_{S0} , R_{S1} , and so forth), multiplexer impedance (R_{MUX}), multiplexer capacitance (C_{MUX}), op amp input capacitance (C_{OPA}), and the stray PCB capacitance at the output of the multiplexer (C_{STRAY}). In this example, the total output capacitance is the combination of the multiplexer output capacitance, the op amp input capacitance, and the stray capacitance ($C_{MUX} + C_{OPA} + C_{STRAY}$) = 15pF. When switching to a channel, make sure this capacitance is charged to the sensor output voltage with the source resistance and the multiplexer resistance ($R_{S0} + R_{MUX}$).

[Equation 2](#) estimates the number of time constants required for N bits of settling. For this example, to achieve 16-bit settling, 11.09 time constants are required. Thus, as computed in [Equation 3](#) and [Equation 4](#), for channel 0 the required settling time is 167ns.

$$N_{TC} = \ln(2^{16}) = 11.09 \quad (2)$$

$$\text{Settling Time Required} = (R_{S0} + R_{MUX}) \times (C_{MUX} + C_{OPA} + C_{STRAY}) \times N_{TC} \quad (3)$$

$$\text{Settling Time Required} = (1k\Omega) \times (15pF) \times 11.09 = 167ns \quad (4)$$

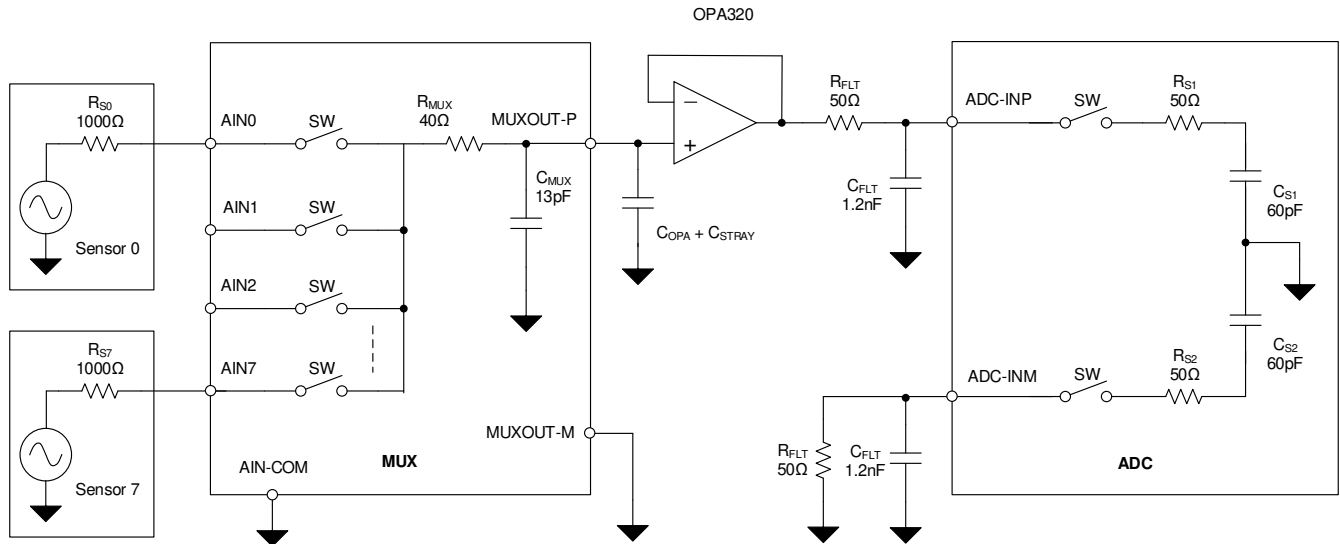

Figure 8-2. Direct Sensor Interface With the ADS816x in an 8-Channel, Single-Ended Configuration

When operating at 1MSPS in either manual mode, auto sequence mode, or custom channel sequencing mode, a 900ns settling time is available at the analog inputs of the multiplexer. Using Equation 4, the maximum sensor output impedance for a direct connection is 5.4kΩ.

Figure 8-3 shows that the multiplexer inputs are driven using an amplifier. The multiplexer outputs are connected to the ADC inputs directly. For best distortion performance, place an amplifier between the multiplexer and the ADC as shown in Figure 8-2.

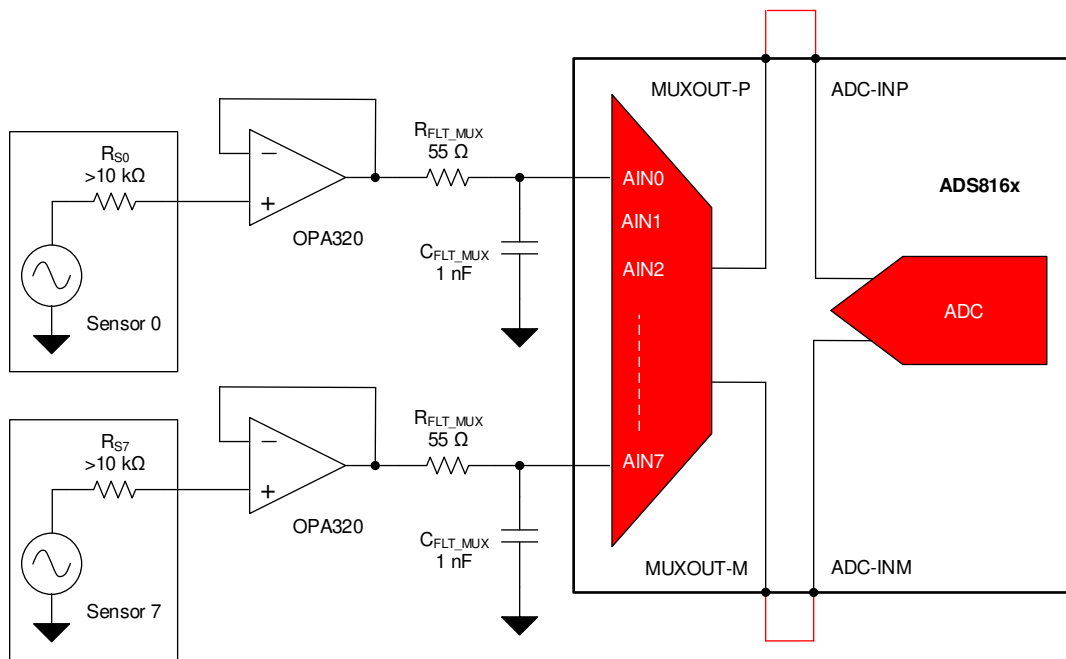

Figure 8-3. High Output Impedance Sensor Interface

8.2 Typical Applications

8.2.1 1MSPS DAQ Circuit With Lowest Distortion and Noise Performance

Figure 8-4 shows an 8-channel and 1MSPS solution with minimum external components. This solution significantly reduces solution size and power by not requiring amplifiers on every analog input.

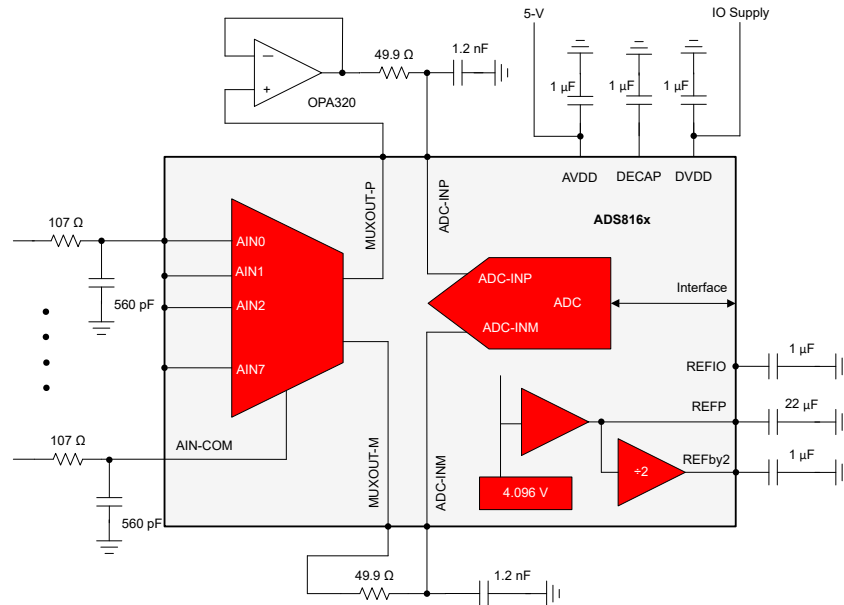

Figure 8-4. 1MSPS DAQ Circuit With Lowest Distortion and Noise Performance

8.2.1.1 Design Requirements

Table 8-1 lists the design parameters for this example.

Table 8-1. Design Parameters

DESIGN PARAMETER	EXAMPLE VALUE
SNR	≥ 92dB
THD	≤ -108dB
Throughput	1MSPS
Input signal frequency	≤100kHz

8.2.1.2 Detailed Design Procedure

The procedure discussed in this section is applicable for any ADS816x application circuit. See the [Example Schematic](#) section for the final design for this example.

- All ADS816x applications require the supply and reference decoupling as given in the [Example Schematic](#) and [Layout](#) sections.
- Select an input amplifier for rapid settling when the multiplexer switches channels. This selection is covered in the [Multiplexer Input Connection](#) section. The [OPA320](#) buffer and associated RC filter illustrated in [Figure 8-3](#) meet these requirements.

8.2.1.3 Application Curve

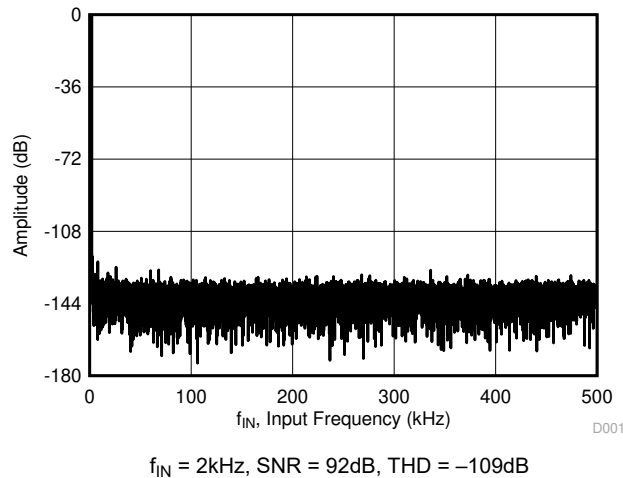

Figure 8-5. FFT Plot: ADS8168

Power Supply Recommendations

The ADS816x has two separate power supplies: AVDD and DVDD. The internal reference, reference buffer, multiplexer, and the internal LDO operate on AVDD. The ADC core operates on the LDO output (available on the DECAP pin). DVDD is used for setting the logic levels on the digital interface. AVDD and DVDD are independently set to any value within the permissible ranges. During normal operation, if any voltage on the AVDD supply drops below the AVDD minimum specification, then ramp the AVDD supply down to ≤ 0.7V before power-up. Also during power-up, make sure AVDD monotonously rises to the desired operating voltage above the minimum AVDD specification.

When using an internal reference, set AVDD so that $4.5V \leq AVDD \leq 5.5V$.

The AVDD supply voltage value defines the permissible range for the external reference voltage, V_{REF}, on the REFIO pin. To use the external reference voltage (V_{REF}), set AVDD such that $3V \leq AVDD \leq (AVDD + 0.3)V$.

As shown in [Figure 8-6](#), place a minimum 1 μ F decoupling capacitor between the AVDD and GND pins and between the DVDD and GND pins. Use a minimum 1 μ F decoupling capacitor between the DECAP and GND pins.

There are no specific requirements with regard to the power-supply sequencing of the device. However, issue a reset after the supplies are powered and stable to make sure the device is properly configured.

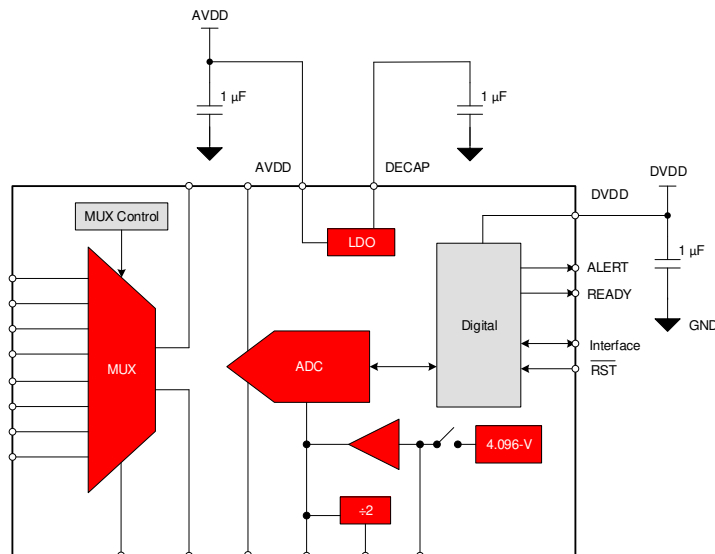

Figure 8-6. Power-Supply Decoupling

8.3 Layout

8.3.1 Layout Guidelines

This section provides some layout guidelines for achieving optimum performance with the ADS816x.

8.3.1.1 Analog Signal Path

As illustrated in [Figure 8-8](#), the analog input signals are routed in opposite directions to the digital connections. The reference decoupling components are kept away from the switching digital signals. This arrangement prevents noise generated by digital switching activity from coupling to sensitive analog signals.

8.3.1.2 Grounding and PCB Stack-Up

Low inductance grounding is critical for achieving optimum performance. Place all critical components of the signal chain on the same PCB layer as the ADS816x.

For lowest inductance grounding, connect the GND pins of the ADS816x (pins 1, 21, and 31) and reference ground REFm (pin 4) directly to the device thermal pad. Connect the device thermal pad to the PCB ground using four vias; see [Figure 8-8](#).

8.3.1.3 Decoupling of Power Supplies

Use wide traces or a dedicated power-supply plane to minimize trace inductance. Place 1 μ F, X7R-grade, ceramic decoupling capacitors in close proximity on AVDD (pin 32), DECAP (pin 2), DVDD (pin 30), and REFby2 (pin 7). Avoid placing vias between any supply pin and the respective decoupling capacitor.

8.3.1.4 Reference Decoupling

When using the internal reference (see the [Reference](#) section), make sure REFIO (pin 3) has a 1 μ F, X7R-grade, ceramic capacitor with at least a 10V rating. Place this capacitor close to the REFIO pin, as illustrated in [Figure 8-8](#). In cases where an external reference is used, see the reference component data sheet for filtering capacitor requirements.

8.3.1.5 Reference Buffer Decoupling

Dynamic currents are present at the REFP and REFM pins during the conversion phase, and excellent decoupling is required to achieve optimum performance. Place a 22 μ F, X7R-grade, ceramic capacitor with at least a 10V rating between the REFP and the REFM pins, as illustrated in [Figure 8-8](#). Select 0603- or 0805-size capacitors to keep the equivalent series inductance (ESL) low.

8.3.1.6 Multiplexer Input Decoupling

Minimizing channel-to-channel parasitic capacitance reduces the crosstalk induced on the PCB. This lower capacitance is achieved by increasing the spacing between the analog traces to the multiplexer input.

In [Figure 8-8](#), each multiplexer input has an RC filter. Use C0G- or NPO-type capacitors in the RC filter to help reduce settling when switching between multiplexer channels. When not switching the multiplexer, as discussed in [Figure 6-12](#) and [Figure 6-13](#), omit the RC filter.

8.3.1.7 ADC Input Decoupling

Dynamic currents are also present at the ADC analog inputs (pins 18 and 19) of the ADS816x. Use C0G- or NPO-type capacitors to decouple these inputs. With these type of capacitors, capacitance remains almost constant over the full input voltage range. Lower-quality capacitors (such as X5R and X7R) have large capacitance changes over the full input voltage range that potentially cause degradation in device performance.

In [Figure 8-8](#), each multiplexer input has an RC filter that helps reduce settling when switching between multiplexer channels. When not switching the multiplexer, as discussed in [Figure 6-12](#) and [Figure 6-13](#), omit the RC filter.

8.3.1.8 Example Schematic

Figure 8-7 shows the schematic used for Figure 8-8.

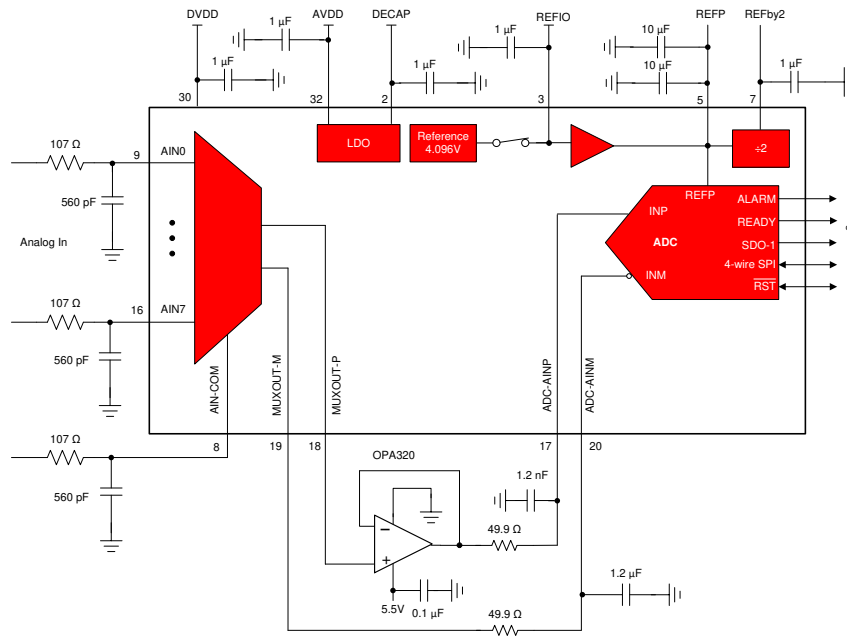

Figure 8-7. Example Schematic for Figure 8-8

8.3.2 Layout Example

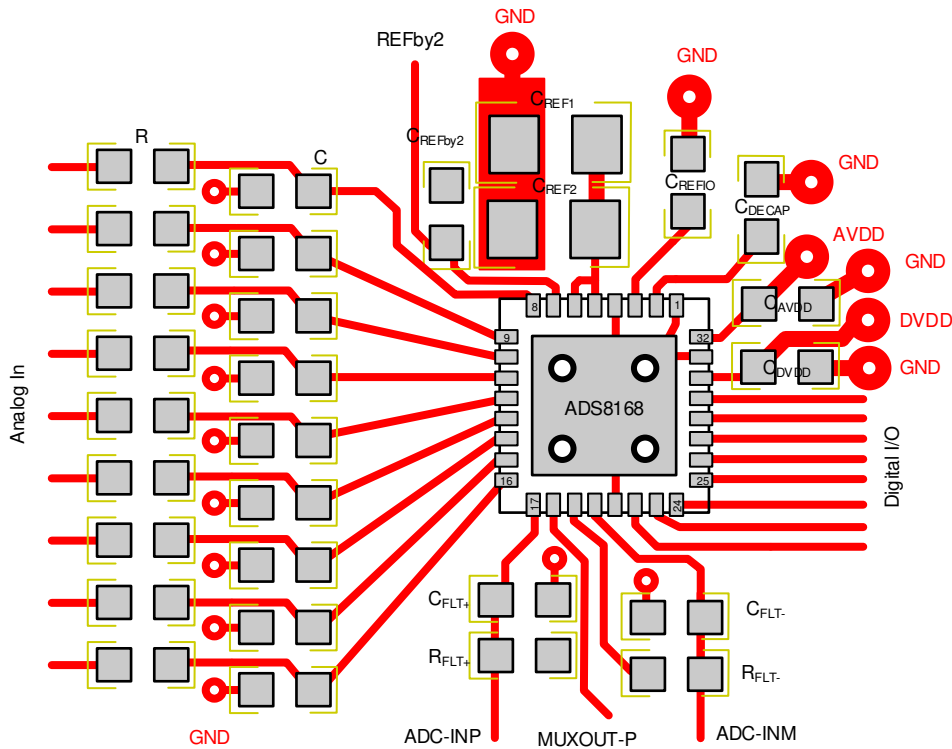

Figure 8-8. Recommended Layout

9 Device and Documentation Support

9.1 Documentation Support

9.1.1 Related Documentation

For related documentation see the following:

- Texas Instruments, [16-Bit 1-MSPS Data Acquisition Reference Design for Single-Ended Multiplexed Applications design guide](#)
- Texas Instruments, [OPAx625 High-Bandwidth, High-Precision, Low THD+N, 16-Bit and 18-Bit Analog-to-Digital Converter \(ADC\) Drivers data sheet](#)
- Texas Instruments, [THS4551 Low Noise, Precision, 150MHz, Fully Differential Amplifier data sheet](#)
- Texas Instruments, [OPAx320x Precision, 20-MHz, 0.9-pA, Low-Noise, RRIO, CMOS Operational Amplifier With Shutdown data sheet](#)
- Texas Instruments, [1 MHz, Single-Supply, Photodiode Amplifier Reference Design reference guide](#)
- Texas Instruments, [Simplified System Design with Precision Multichannel ADC application brief](#)

9.2 Receiving Notification of Documentation Updates

To receive notification of documentation updates, navigate to the device product folder on ti.com. Click on *Notifications* to register and receive a weekly digest of any product information that has changed. For change details, review the revision history included in any revised document.

9.3 Support Resources

[TI E2E™ support forums](#) are an engineer's go-to source for fast, verified answers and design help — straight from the experts. Search existing answers or ask your own question to get the quick design help you need.

Linked content is provided "AS IS" by the respective contributors. They do not constitute TI specifications and do not necessarily reflect TI's views; see TI's [Terms of Use](#).

9.4 Trademarks

TI E2E™ is a trademark of Texas Instruments.
All trademarks are the property of their respective owners.

9.5 Electrostatic Discharge Caution



This integrated circuit can be damaged by ESD. Texas Instruments recommends that all integrated circuits be handled with appropriate precautions. Failure to observe proper handling and installation procedures can cause damage.

ESD damage can range from subtle performance degradation to complete device failure. Precision integrated circuits may be more susceptible to damage because very small parametric changes could cause the device not to meet its published specifications.

9.6 Glossary

[TI Glossary](#) This glossary lists and explains terms, acronyms, and definitions.

10 Revision History

NOTE: Page numbers for previous revisions may differ from page numbers in the current version.

Changes from Revision C (November 2019) to Revision D (June 2024)	Page
• Deleted <i>Early switching</i> sub-bullet from <i>Multiplexer</i> bullet.....	1
• Changed 70MHz to 50MHz in second <i>Enhanced SPI</i> bullet.....	1
• Changed <i>Applications</i> section.....	1
• Changed REFIO pin description.....	3
• Changed f_{CLK} maximum specifications from 70MHz to 50MHz and 68MHz to 50MHz	9
• Changed t_{ph_CSCK} parameter symbol to t_{su_CSCK}	9
• Changed <i>Timing Diagrams</i>	11
• Deleted <i>Early Switching for Direct Sensor Interface</i> section.....	22
• Changed <i>Reference</i> section.....	23
• Deleted <i>Internal Reference, External Reference, and Reference Buffer</i> sections.....	23
• Deleted <i>Manual Mode With No Channel Switching Timing Diagram</i> figure and description from <i>Manual Mode</i> section.....	28
• Changed <i>Capture Edge</i> to <i>Launch Edge</i> in <i>SPI Protocols for Reading From the Device</i> table and changed both timing diagrams in <i>SPI Protocols With a Single SDO</i> section.....	37
• Changed both timing diagrams in <i>SPI Protocols With Dual SDO</i> section.....	39
• Changed 1010 01100 to xA5A5 in DATA_VAL bit description of <i>DATA_CNTL Register</i>	47
• Added discussion of odd number of 1s to PARITY_EN bit description.....	47
• Changed footnote of <i>REFby2_OFST[2:0] Settings</i> table.....	50
• Changed CCS_SEQ_LOOP register address from 8Bh to 8Ah	58
• Changed input signal frequency from 100kSPS to 100kHz in <i>Design Parameters</i> table.....	71
• Deleted second bullet from <i>Detailed Design Procedure</i> section in <i>1MSPS DAQ Circuit With Lowest Distortion and Noise Performance</i> typical application.....	71

Changes from Revision B (December 2018) to Revision C (November 2019)	Page
• Changed document title from <i>ADS816x 8-Channel, 16-Bit, 1-MSPS, SAR ADC With Easy-to-Drive Analog Inputs</i> to <i>ADS816x 8-Channel, 16-Bit, 1-MSPS, SAR ADC With Direct Sensor Interface</i>	1
• Changed <i>Low-leakage multiplexer with sequencer</i> to <i>Multiplexer with channel sequencer</i> in <i>Features</i> section.....	1
• Changed <i>Wide input range</i> to <i>Wide operating range</i> in <i>Features</i> section, changed and added sub-bullets to this <i>Features</i> bullet	1
• Deleted hysteresis from alarm threshold discussion in <i>Description</i> section	1
• Changed title of <i>ADS816x Block Diagram</i> figure.....	1
• Changed <i>AUTO_SEQ_CFG1 = 0x84</i> to <i>AUTO_SEQ_CFG1 = 0x44</i> in <i>Auto Sequence Mode</i> section.....	30
• Changed default settings from 1 to 0xFF in <i>Channel Sample Count</i> column of <i>Custom Channel Sequencing Configuration Space</i> table.....	32
• Changed reset value from <i>R/W-0000 0001b</i> to <i>R/W-1111 1111b</i> in <i>REPEAT_INDEX_m Registers</i> section.....	59
• Changed description of registers 78h, 7Ah, 7Ch, and 7Eh in <i>Digital Window Comparator Configuration Registers Mapping</i> table	60
• Changed <i>ALERT_LO_STATUS Register</i> section and name	64
• Changed <i>ALERT_STATUS Register</i> section and name.....	65
• Condensed register description to cover all bits for simplicity.....	65
• Changed <i>CURR_ALERT_LO_STATUS Register</i> section and name	66
• Changed <i>CURR_ALERT_STATUS Register</i> section and name.....	67

11 Mechanical, Packaging, and Orderable Information

The following pages include mechanical, packaging, and orderable information. This information is the most current data available for the designated devices. This data is subject to change without notice and revision of this document. For browser-based versions of this data sheet, refer to the left-hand navigation.

PACKAGING INFORMATION

Orderable part number	Status (1)	Material type (2)	Package Pins	Package qty Carrier	RoHS (3)	Lead finish/ Ball material (4)	MSL rating/ Peak reflow (5)	Op temp (°C)	Part marking (6)
ADS8166IRHBR	Active	Production	VQFN (RHB) 32	3000 LARGE T&R	Yes	NIPDAU	Level-2-260C-1 YEAR	-40 to 125	ADS 8166
ADS8166IRHBR.B	Active	Production	VQFN (RHB) 32	3000 LARGE T&R	Yes	NIPDAU	Level-2-260C-1 YEAR	-40 to 125	ADS 8166
ADS8166IRHBRG4	Active	Production	VQFN (RHB) 32	3000 LARGE T&R	Yes	NIPDAU	Level-2-260C-1 YEAR	-40 to 125	ADS 8166
ADS8166IRHBRG4.B	Active	Production	VQFN (RHB) 32	3000 LARGE T&R	Yes	NIPDAU	Level-2-260C-1 YEAR	-40 to 125	ADS 8166
ADS8166IRHBT	Active	Production	VQFN (RHB) 32	250 SMALL T&R	Yes	SN	Level-2-260C-1 YEAR	-40 to 125	ADS 8166
ADS8166IRHBT.B	Active	Production	VQFN (RHB) 32	250 SMALL T&R	Yes	SN	Level-2-260C-1 YEAR	-40 to 125	ADS 8166
ADS8167IRHBR	Active	Production	VQFN (RHB) 32	3000 LARGE T&R	Yes	SN	Level-2-260C-1 YEAR	-40 to 125	ADS 8167
ADS8167IRHBR.B	Active	Production	VQFN (RHB) 32	3000 LARGE T&R	Yes	SN	Level-2-260C-1 YEAR	-40 to 125	ADS 8167
ADS8167IRHBT	Active	Production	VQFN (RHB) 32	250 SMALL T&R	Yes	SN	Level-2-260C-1 YEAR	-40 to 125	ADS 8167
ADS8167IRHBT.B	Active	Production	VQFN (RHB) 32	250 SMALL T&R	Yes	SN	Level-2-260C-1 YEAR	-40 to 125	ADS 8167
ADS8168IRHBR	Active	Production	VQFN (RHB) 32	3000 LARGE T&R	Yes	NIPDAU	Level-2-260C-1 YEAR	-40 to 125	ADS 8168
ADS8168IRHBR.B	Active	Production	VQFN (RHB) 32	3000 LARGE T&R	Yes	NIPDAU	Level-2-260C-1 YEAR	-40 to 125	ADS 8168
ADS8168IRHBT	Active	Production	VQFN (RHB) 32	250 SMALL T&R	Yes	SN	Level-2-260C-1 YEAR	-40 to 125	ADS 8168
ADS8168IRHBT.B	Active	Production	VQFN (RHB) 32	250 SMALL T&R	Yes	SN	Level-2-260C-1 YEAR	-40 to 125	ADS 8168
ADS8168IRHBTG4	Active	Production	VQFN (RHB) 32	250 SMALL T&R	Yes	NIPDAU	Level-2-260C-1 YEAR	-40 to 125	ADS 8168
ADS8168IRHBTG4.B	Active	Production	VQFN (RHB) 32	250 SMALL T&R	Yes	NIPDAU	Level-2-260C-1 YEAR	-40 to 125	ADS 8168

(1) **Status:** For more details on status, see our [product life cycle](#).

- (2) **Material type:** When designated, preproduction parts are prototypes/experimental devices, and are not yet approved or released for full production. Testing and final process, including without limitation quality assurance, reliability performance testing, and/or process qualification, may not yet be complete, and this item is subject to further changes or possible discontinuation. If available for ordering, purchases will be subject to an additional waiver at checkout, and are intended for early internal evaluation purposes only. These items are sold without warranties of any kind.
- (3) **RoHS values:** Yes, No, RoHS Exempt. See the [TI RoHS Statement](#) for additional information and value definition.
- (4) **Lead finish/Ball material:** Parts may have multiple material finish options. Finish options are separated by a vertical ruled line. Lead finish/Ball material values may wrap to two lines if the finish value exceeds the maximum column width.
- (5) **MSL rating/Peak reflow:** The moisture sensitivity level ratings and peak solder (reflow) temperatures. In the event that a part has multiple moisture sensitivity ratings, only the lowest level per JEDEC standards is shown. Refer to the shipping label for the actual reflow temperature that will be used to mount the part to the printed circuit board.
- (6) **Part marking:** There may be an additional marking, which relates to the logo, the lot trace code information, or the environmental category of the part.

Multiple part markings will be inside parentheses. Only one part marking contained in parentheses and separated by a "~" will appear on a part. If a line is indented then it is a continuation of the previous line and the two combined represent the entire part marking for that device.

Important Information and Disclaimer: The information provided on this page represents TI's knowledge and belief as of the date that it is provided. TI bases its knowledge and belief on information provided by third parties, and makes no representation or warranty as to the accuracy of such information. Efforts are underway to better integrate information from third parties. TI has taken and continues to take reasonable steps to provide representative and accurate information but may not have conducted destructive testing or chemical analysis on incoming materials and chemicals. TI and TI suppliers consider certain information to be proprietary, and thus CAS numbers and other limited information may not be available for release.

In no event shall TI's liability arising out of such information exceed the total purchase price of the TI part(s) at issue in this document sold by TI to Customer on an annual basis.

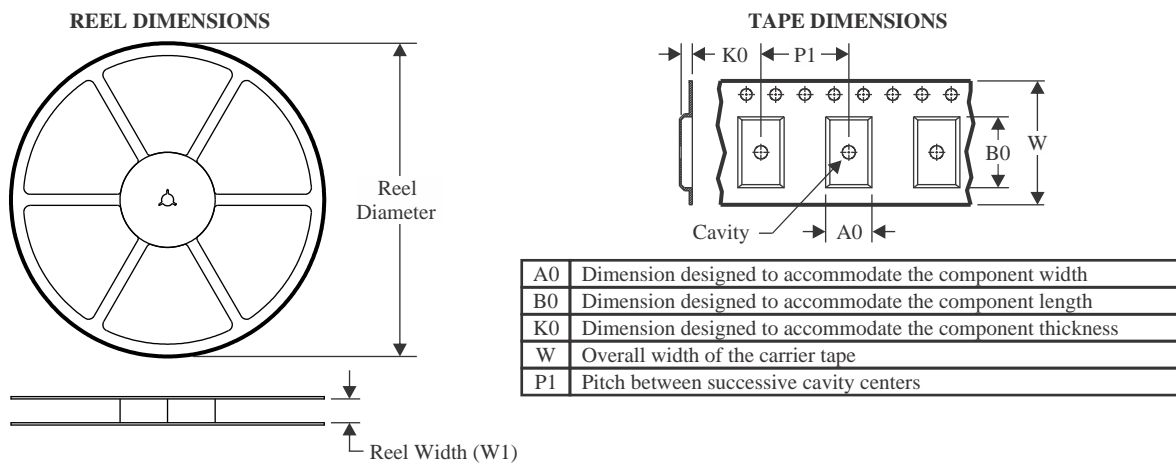
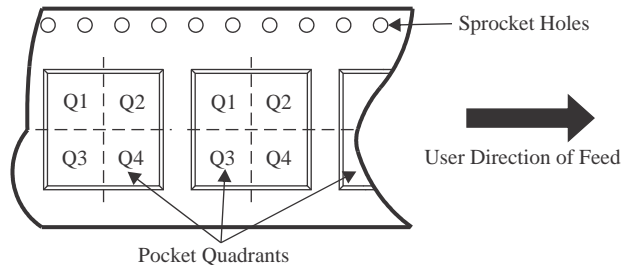
TAPE AND REEL INFORMATION

QUADRANT ASSIGNMENTS FOR PIN 1 ORIENTATION IN TAPE

*All dimensions are nominal

Device	Package Type	Package Drawing	Pins	SPQ	Reel Diameter (mm)	Reel Width W1 (mm)	A0 (mm)	B0 (mm)	K0 (mm)	P1 (mm)	W (mm)	Pin1 Quadrant
ADS8166IRHBR	VQFN	RHB	32	3000	330.0	12.4	5.3	5.3	1.1	8.0	12.0	Q2
ADS8166IRHBRG4	VQFN	RHB	32	3000	330.0	12.4	5.3	5.3	1.1	8.0	12.0	Q2
ADS8166IRHBT	VQFN	RHB	32	250	180.0	12.4	5.3	5.3	1.1	8.0	12.0	Q2
ADS8167IRHBR	VQFN	RHB	32	3000	330.0	12.4	5.3	5.3	1.1	8.0	12.0	Q2
ADS8167IRHBT	VQFN	RHB	32	250	180.0	12.4	5.3	5.3	1.1	8.0	12.0	Q2
ADS8168IRHBR	VQFN	RHB	32	3000	330.0	12.4	5.3	5.3	1.1	8.0	12.0	Q2
ADS8168IRHBT	VQFN	RHB	32	250	180.0	12.4	5.3	5.3	1.1	8.0	12.0	Q2
ADS8168IRHBTG4	VQFN	RHB	32	250	180.0	12.4	5.3	5.3	1.1	8.0	12.0	Q2

TAPE AND REEL BOX DIMENSIONS

*All dimensions are nominal

Device	Package Type	Package Drawing	Pins	SPQ	Length (mm)	Width (mm)	Height (mm)
ADS8166IRHBR	VQFN	RHB	32	3000	367.0	367.0	35.0
ADS8166IRHBRG4	VQFN	RHB	32	3000	367.0	367.0	35.0
ADS8166IRHBT	VQFN	RHB	32	250	210.0	185.0	35.0
ADS8167IRHBR	VQFN	RHB	32	3000	367.0	367.0	35.0
ADS8167IRHBT	VQFN	RHB	32	250	210.0	185.0	35.0
ADS8168IRHBR	VQFN	RHB	32	3000	367.0	367.0	35.0
ADS8168IRHBT	VQFN	RHB	32	250	210.0	185.0	35.0
ADS8168IRHBTG4	VQFN	RHB	32	250	210.0	185.0	35.0

GENERIC PACKAGE VIEW

RHB 32

VQFN - 1 mm max height

5 x 5, 0.5 mm pitch

PLASTIC QUAD FLATPACK - NO LEAD

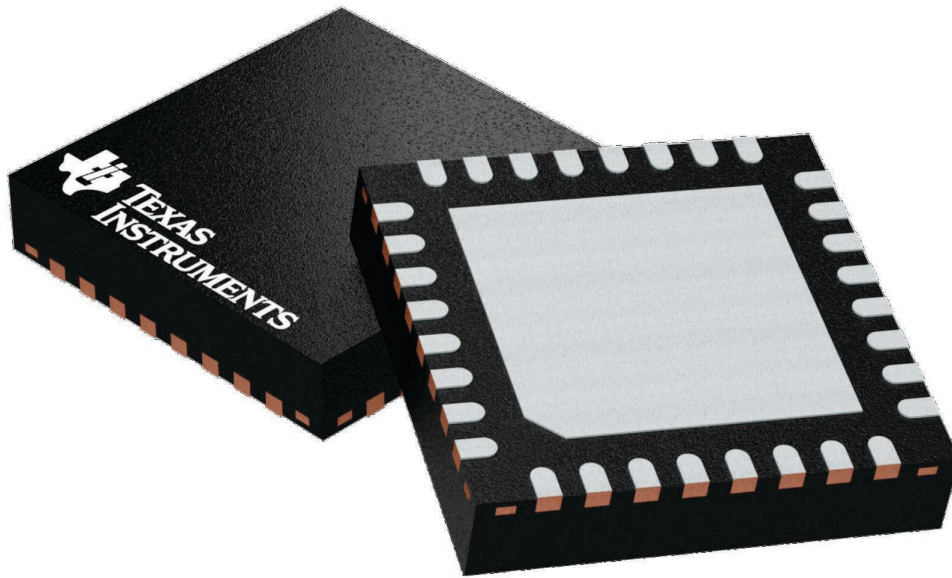

Images above are just a representation of the package family, actual package may vary.
Refer to the product data sheet for package details.

4224745/A

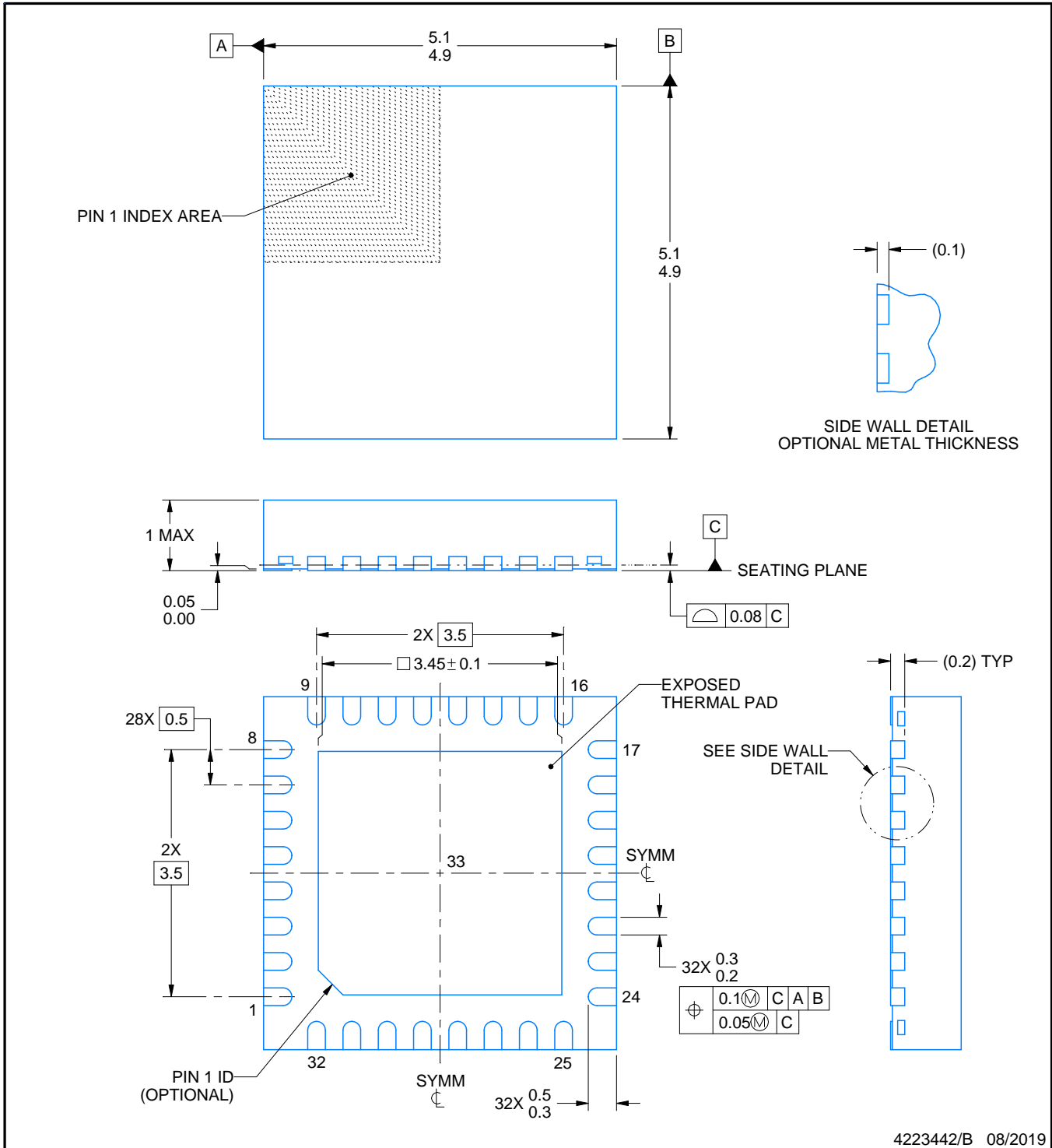
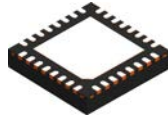

4223442/B 08/2019

NOTES:

1. All linear dimensions are in millimeters. Any dimensions in parenthesis are for reference only. Dimensioning and tolerancing per ASME Y14.5M.
2. This drawing is subject to change without notice.
3. The package thermal pad must be soldered to the printed circuit board for thermal and mechanical performance.

EXAMPLE BOARD LAYOUT

RHB0032E

VQFN - 1 mm max height

PLASTIC QUAD FLATPACK - NO LEAD

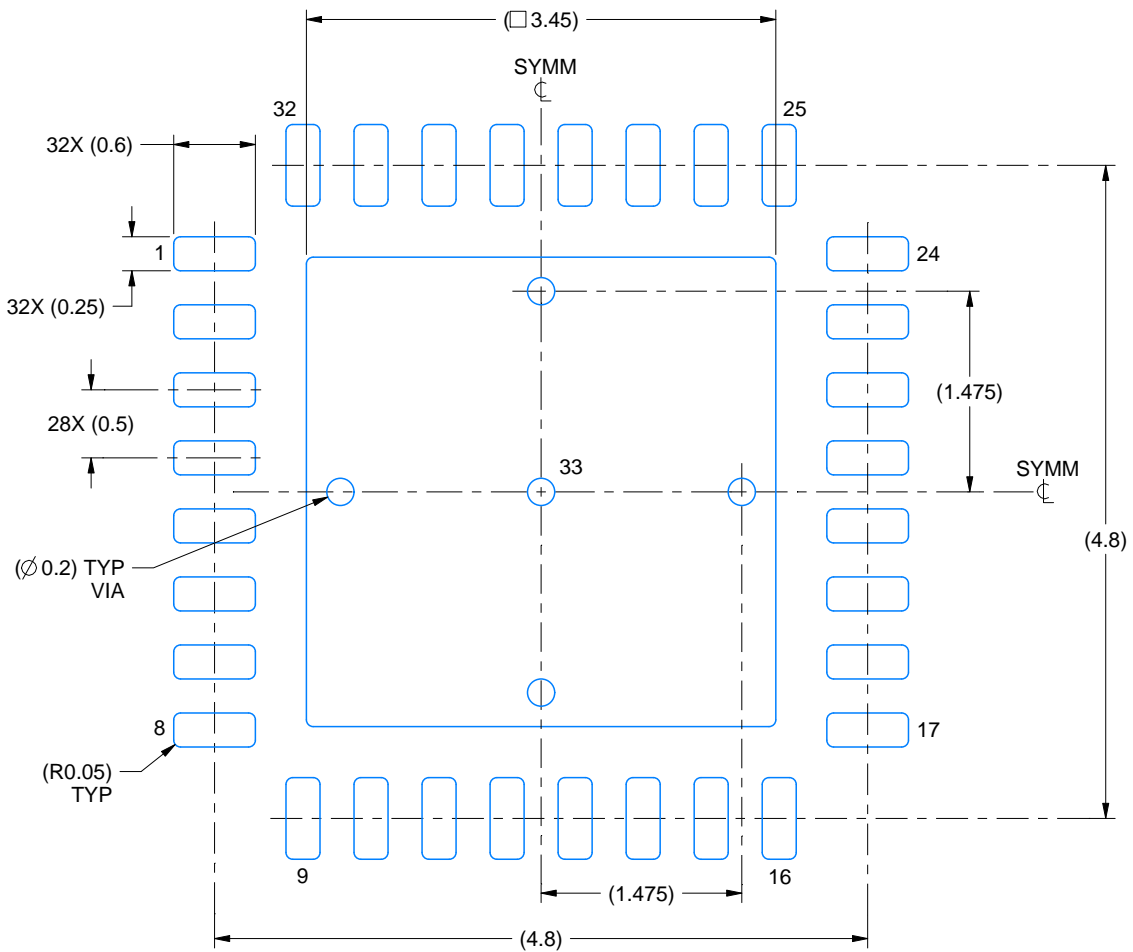

LAND PATTERN EXAMPLE
SCALE:18X

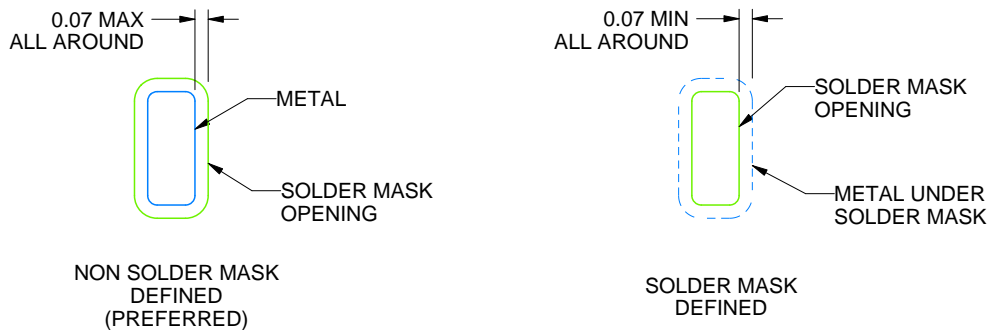

SOLDER MASK DETAILS

4223442/B 08/2019

NOTES: (continued)

4. This package is designed to be soldered to a thermal pad on the board. For more information, see Texas Instruments literature number SLUA271 (www.ti.com/lit/slua271).
5. Vias are optional depending on application, refer to device data sheet. If any vias are implemented, refer to their locations shown on this view. It is recommended that vias under paste be filled, plugged or tented.

EXAMPLE STENCIL DESIGN

RHB0032E

VQFN - 1 mm max height

PLASTIC QUAD FLATPACK - NO LEAD

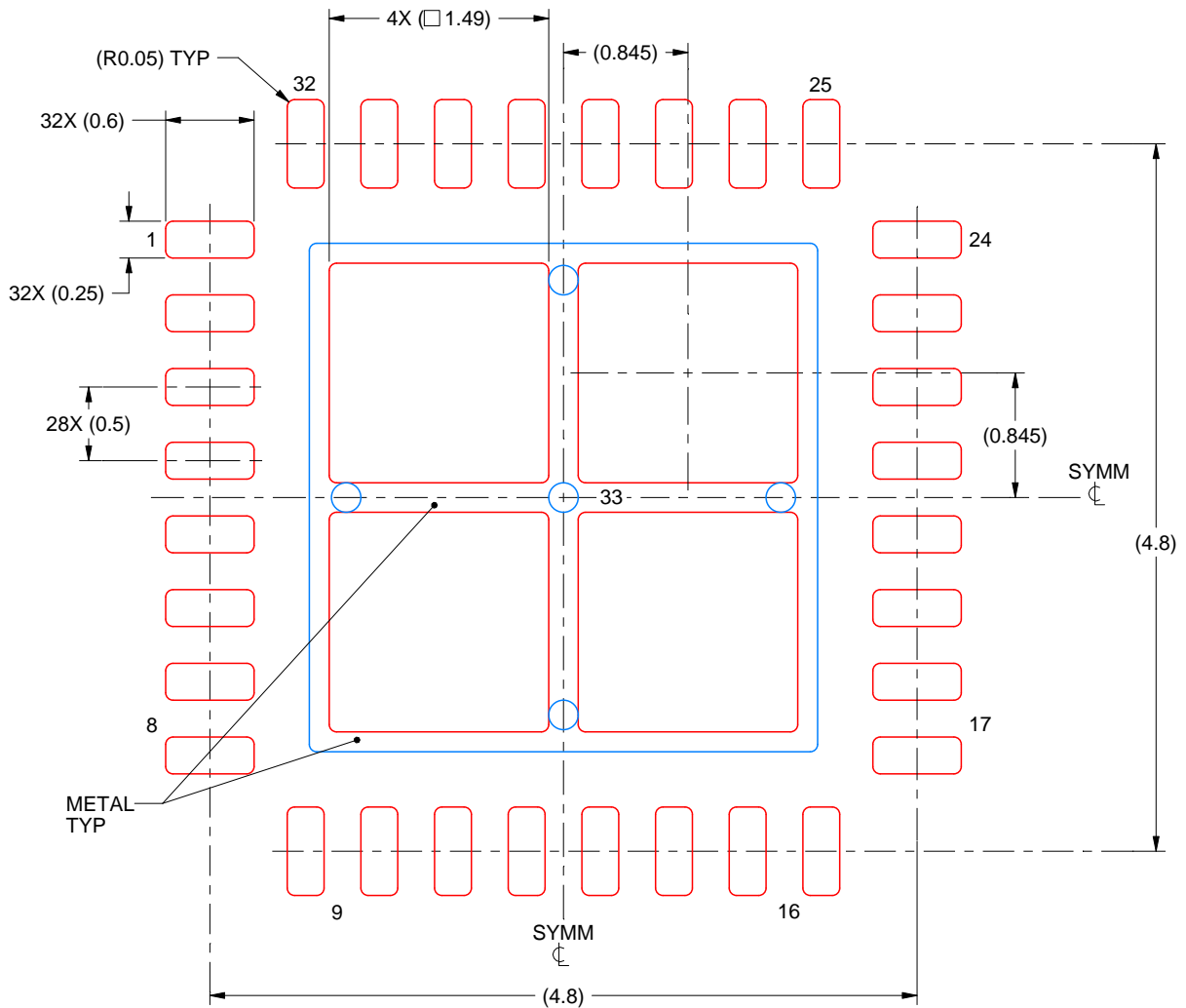

SOLDER PASTE EXAMPLE
 BASED ON 0.125 mm THICK STENCIL

EXPOSED PAD 33:
 75% PRINTED SOLDER COVERAGE BY AREA UNDER PACKAGE
 SCALE:20X

4223442/B 08/2019

NOTES: (continued)

6. Laser cutting apertures with trapezoidal walls and rounded corners may offer better paste release. IPC-7525 may have alternate design recommendations.

IMPORTANT NOTICE AND DISCLAIMER

TI PROVIDES TECHNICAL AND RELIABILITY DATA (INCLUDING DATASHEETS), DESIGN RESOURCES (INCLUDING REFERENCE DESIGNS), APPLICATION OR OTHER DESIGN ADVICE, WEB TOOLS, SAFETY INFORMATION, AND OTHER RESOURCES "AS IS" AND WITH ALL FAULTS, AND DISCLAIMS ALL WARRANTIES, EXPRESS AND IMPLIED, INCLUDING WITHOUT LIMITATION ANY IMPLIED WARRANTIES OF MERCHANTABILITY, FITNESS FOR A PARTICULAR PURPOSE OR NON-INFRINGEMENT OF THIRD PARTY INTELLECTUAL PROPERTY RIGHTS.

These resources are intended for skilled developers designing with TI products. You are solely responsible for (1) selecting the appropriate TI products for your application, (2) designing, validating and testing your application, and (3) ensuring your application meets applicable standards, and any other safety, security, regulatory or other requirements.

These resources are subject to change without notice. TI grants you permission to use these resources only for development of an application that uses the TI products described in the resource. Other reproduction and display of these resources is prohibited. No license is granted to any other TI intellectual property right or to any third party intellectual property right. TI disclaims responsibility for, and you fully indemnify TI and its representatives against any claims, damages, costs, losses, and liabilities arising out of your use of these resources.

TI's products are provided subject to [TI's Terms of Sale](#), [TI's General Quality Guidelines](#), or other applicable terms available either on [ti.com](#) or provided in conjunction with such TI products. TI's provision of these resources does not expand or otherwise alter TI's applicable warranties or warranty disclaimers for TI products. Unless TI explicitly designates a product as custom or customer-specified, TI products are standard, catalog, general purpose devices.

TI objects to and rejects any additional or different terms you may propose.

Copyright © 2026, Texas Instruments Incorporated

Last updated 10/2025