

# ADC3683-SEP ADC3683-EP 18-bit 65MSPS Low Noise Low Power Dual Channel ADC

## 1 Features

- Radiation tolerant (-SEP only):
  - Single-event latch-up (SEL) immune up to LET = 43 MeV-cm<sup>2</sup>/mg
  - Single-event functional interrupt (SEFI) characterized up to LET = 43 MeV-cm<sup>2</sup>/mg
  - Total ionizing dose (TID): 30 krad(Si)
- Enhanced product (-EP and -SEP):
  - Meets ASTM E595 outgassing specification
  - Vendor item drawing (VID)
  - Temperature range: -55°C to 105°C
  - One fabrication, assembly, and test site
  - Gold bond wire, NiPdAu lead finish
  - Wafer lot traceability
  - Extended product life cycle
- Dual channel, 65 MSPS ADC
- 18-bit resolution (no missing codes)
- Noise floor: -160 dBFS/Hz
- Low power 94 mW/ch (at 65MSPS)
- Latency: 1-2 clock cycles
- INL: ±7, DNL: ±0.7 LSB (typical)
- Reference options: external or internal
- On-chip DSP (optional/bypassable)
  - Decimation by 2, 4, 8, 16, 32
  - 32-bit NCO
- Serial LVDS digital interface (2-, 1- and 1/2-wire)
- Small footprint: 40-QFN (5x5 mm) package
- Spectral performance ( $f_{IN} = 5\text{MHz}$ ):
  - SNR: 83.8dBFS
  - SFDR: 89dBc HD2, HD3
  - SFDR: 101dBFS Worst spur

## 2 Applications

- [Satellite optical](#) communications payloads
- [Satellite imaging payloads](#)
- Satellite communication payloads
- Satellite RADAR and LIDAR payloads

## 3 Description

The ADC3683-xEP is a low noise, ultra-low power 18-bit 65MSPS high-speed dual channel ADC. Designed for lowest noise performance, the device delivers a noise spectral density of -160dBFS/Hz combined with linearity and dynamic range. The ADC3683-xEP offers excellent DC precision together with IF sampling support. Making the device designed for a wide range of applications. High-speed control loops benefit from the short latency as low as only 1 clock cycle. The ADC consumes only 94mW/ch at 65MSPS, and the power consumption scales well with lower sampling rates

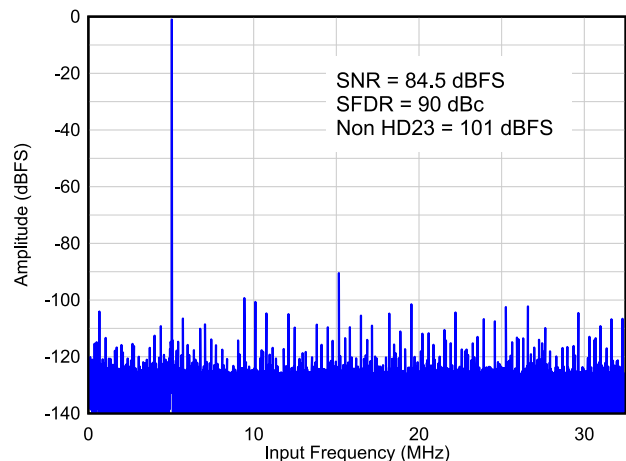
The ADC3683-xEP uses a serial LVDS (SLVDS) interface to output the data which minimizes the number of digital interconnects. The device supports two-lane, one-lane and half-lane options. The device is available in a 40-pin QFN package (5 mm x 5 mm) and supports the extended temperature range from -55 to +105°C

### Package Information

PART NUMBER	PACKAGE <sup>(1)</sup>	PACKAGE SIZE <sup>(2)</sup>
ADC3683-SEP	VQFN (40)	5mm x 5mm
ADC3683-EP		

(1) For more information, see [Section 12](#).

(2) The package size (length × width) is a nominal value and includes pins, where applicable.



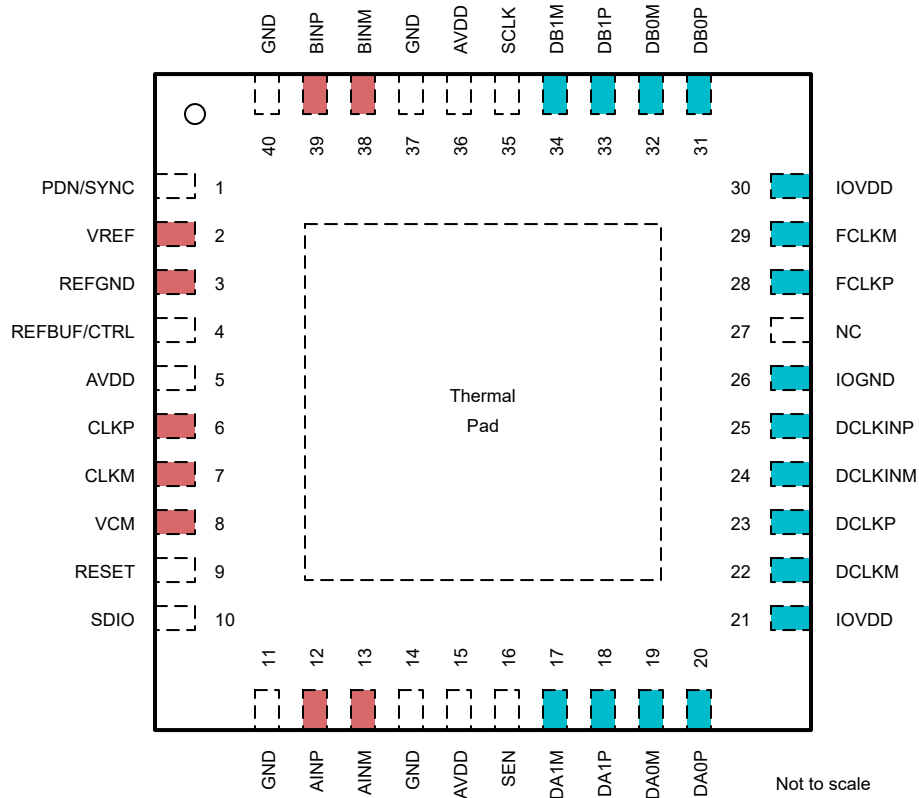
FFT:  $F_s = 65\text{MSPS}$ ,  $F_{in} = 5\text{MHz}$



## Table of Contents

<b>1 Features</b> .....	1	7.5 Programming.....	48
<b>2 Applications</b> .....	1	<b>8 Application Information Disclaimer</b> .....	50
<b>3 Description</b> .....	1	8.1 Application Information.....	50
<b>4 Pin Configuration and Functions</b> .....	3	8.2 Typical Application.....	50
<b>5 Specifications</b> .....	5	8.3 Initialization Set Up.....	54
5.1 Absolute Maximum Ratings.....	5	8.4 Power Supply Recommendations.....	55
5.2 ESD Ratings.....	5	8.5 Layout.....	56
5.3 Recommended Operating Conditions.....	5	<b>9 Register Map</b> .....	58
5.4 Thermal Information.....	5	9.1 Detailed Register Description.....	59
5.5 Electrical Characteristics - Power Consumption.....	6	<b>10 Device and Documentation Support</b> .....	73
5.6 Electrical Characteristics - DC Specifications.....	7	10.1 Receiving Notification of Documentation Updates..	73
5.7 Electrical Characteristics - AC Specifications.....	9	10.2 Support Resources.....	73
5.8 Timing Requirements.....	10	10.3 Trademarks.....	73
5.9 Typical Characteristics - ADC3683.....	12	10.4 Electrostatic Discharge Caution.....	73
<b>6 Parameter Measurement Information</b> .....	17	10.5 Glossary.....	73
<b>7 Detailed Description</b> .....	19	<b>11 Revision History</b> .....	73
7.1 Overview.....	19	<b>12 Mechanical, Packaging, and Orderable Information</b> .....	73
7.2 Functional Block Diagram.....	19	12.1 Mechanical Data.....	74
7.3 Feature Description.....	20		
7.4 Device Functional Modes.....	46		

## 4 Pin Configuration and Functions



**Figure 4-1. RSB (WQQFN) Package, 40-Pin (Top View)**

**Table 4-1. Pin Functions**

PIN		TYPE	DESCRIPTION
NAME	NO.		
<b>INPUT/REFERENCE</b>			
AINP	12	I	Positive analog input, channel A
AINM	13	I	Negative analog input, channel A
BINP	39	I	Positive analog input, channel B
BINM	38	I	Negative analog input, channel B
VCM	8	O	Common-mode voltage output for the analog inputs, 0.95V
VREF	2	I	External voltage reference input, 1.6V
REFGND	3	I	Reference ground input, 0V
<b>CLOCK</b>			
CLKP	6	I	Positive differential sampling clock input for the ADC
CLKM	7	I	Negative differential sampling clock input for the ADC
<b>CONFIGURATION</b>			
PDN/SYNC	1	I	Power down/Synchronization input. This pin is configured via the SPI interface. Active high. This pin has an internal 21kΩ pull-down resistor.

**Table 4-1. Pin Functions (continued)**

PIN		TYPE	DESCRIPTION
NAME	NO.		
REFBUF/ CTRL	4	I	This pin is used to configure the default sampling clock type and voltage reference source upon power up. There is an internal 100kΩ pull up resistor to AVDD
RESET	9	I	Hardware reset. Active high. This pin has an internal 21kΩ pull-down resistor.
SEN	16	I	Serial interface enable. Active low. This pin has an internal 21kΩ pull-up resistor to AVDD.
SCLK	35	I	Serial interface clock input. This pin has an internal 21kΩ pull-down resistor.
SDIO	10	I/O	Serial interface data input and output. This pin has an internal 21kΩ pull-down resistor.
NC	27	-	Do not connect
<b>DIGITAL INTERFACE</b>			
DA0P	20	O	Positive differential serial LVDS output for lane 0, channel A
DA0M	19	O	Negative differential serial LVDS output for lane 0, channel A
DA1P	18	O	Positive differential serial LVDS output for lane 1, channel A
DA1M	17	O	Negative differential serial LVDS output for lane 1, channel A
DB0P	31	O	Positive differential serial LVDS output for lane 0, channel B
DB0M	32	O	Negative differential serial LVDS output for lane 0, channel B
DB1P	33	O	Positive differential serial LVDS output for lane 1, channel B
DB1M	34	O	Negative differential serial LVDS output for lane 1, channel B
DCLKP	23	O	Positive differential serial LVDS bit clock output.
DCLKM	22	O	Negative differential serial LVDS bit clock output.
FCLKP	28	O	Positive differential serial LVDS frame clock output.
FCLKM	29	O	Negative differential serial LVDS frame clock output.
DCLKINP	25	I	Positive differential serial LVDS bit clock input. Internal 100Ω differential termination.
DCLKINM	24	I	Negative differential serial LVDS bit clock input. Internal 100Ω differential termination.
<b>POWER SUPPLY</b>			
AVDD	5, 15, 36	I	Analog 1.8V power supply
GND	11, 14, 37, 40,	I	Ground, 0V, PowerPAD™
IOVDD	21, 30	I	1.8V power supply for digital interface
IOGND	26	I	Ground, 0V for digital interface

## 5 Specifications

### 5.1 Absolute Maximum Ratings

over operating free-air temperature range (unless otherwise noted)<sup>(1)</sup>

PARAMETER	TEST CONDITIONS	MIN	MAX	UNIT
Supply voltage range, AVDD, IOVDD		-0.3	2.1	V
Supply voltage range, GND, IOGND, REFGND		-0.3	0.3	V
Voltage applied to input pins	AINP/M, BINP/M, CLKP/M, VREF, REFBUF	-0.3	MIN(2.1, AVDD+0.3)	V
	PDN/SYNC, RESET, SCLK, SEN, SDIO	-0.3	MIN(2.1, AVDD+0.3)	
	DCLKINP/M	-0.3	MIN(2.1, IOVDD+0.3)	
Junction temperature, T <sub>J</sub>			125	°C
Storage temperature, T <sub>stg</sub>		-65	150	°C

- (1) Stresses beyond those listed under *Absolute Maximum Ratings* may cause permanent damage to the device. These are stress ratings only, which do not imply functional operation of the device at these or any other conditions beyond those indicated under *Recommended Operating Conditions*. Exposure to absolute-maximum-rated conditions for extended periods may affect device reliability.

### 5.2 ESD Ratings

			VALUE	UNIT
V <sub>(ESD)</sub>	Electrostatic discharge	Human body model (HBM), per ANSI/ESDA/JEDEC JS-001, all pins <sup>(1)</sup>	2500	V
		Charged device model (CDM), per JEDEC specification JESD22-C101, all pins <sup>(2)</sup>	1000	

- (1) JEDEC document JEP155 states that 500-V HBM allows safe manufacturing with a standard ESD control process.  
(2) JEDEC document JEP157 states that 250-V CDM allows safe manufacturing with a standard ESD control process.

### 5.3 Recommended Operating Conditions

over operating free-air temperature range (unless otherwise noted)

		MIN	NOM	MAX	UNIT
Supply voltage range	AVDD <sup>(1)</sup>	1.75	1.8	1.85	V
	IOVDD <sup>(1)</sup>	1.75	1.8	1.85	V
T <sub>A</sub>	Operating free-air temperature	-55		105	°C
T <sub>J</sub>	Operating junction temperature			105 <sup>(2)</sup>	°C

- (1) Measured to GND.  
(2) Prolonged use above this junction temperature may increase the device failure-in-time (FIT) rate.

### 5.4 Thermal Information

THERMAL METRIC <sup>(1)</sup>		ADC3683-SEP	UNIT
		RSB (QFN)	
		40 Pins	
R <sub>θJA</sub>	Junction-to-ambient thermal resistance	30.7	°C/W
R <sub>θJC(top)</sub>	Junction-to-case (top) thermal resistance	16.4	°C/W
R <sub>θJB</sub>	Junction-to-board thermal resistance	10.5	°C/W
Ψ <sub>JT</sub>	Junction-to-top characterization parameter	0.2	°C/W
Ψ <sub>JB</sub>	Junction-to-board characterization parameter	10.5	°C/W
R <sub>θJC(bot)</sub>	Junction-to-case (bottom) thermal resistance	2.0	°C/W

- (1) For more information about traditional and new thermal metrics, see the *Semiconductor and IC Package Thermal Metrics* application report, SPRA953.

## 5.5 Electrical Characteristics - Power Consumption

Typical values at  $T_A = 25^\circ\text{C}$ , full temperature range is  $T_{\text{MIN}} = -55^\circ\text{C}$  to  $T_{\text{MAX}} = 105^\circ\text{C}$ , ADC sampling rate = 65 MSPS, 50% clock duty cycle,  $\text{AVDD} = \text{IOVDD} = 1.8\text{ V}$ , external 1.6 V reference, and  $-1\text{-dBFS}$  differential input, unless otherwise noted

PARAMETER		TEST CONDITIONS	MIN	TYP	MAX	UNIT
<b>ADC3683-SEP: 65 MSPS</b>						
$I_{\text{AVDD}}$	Analog supply current	External reference		63	82	mA
$I_{\text{IOVDD}}$	I/O supply current	2-wire		41	47	
$P_{\text{DIS}}$	Power dissipation	External reference, 2-wire		187	232	mW
$I_{\text{IOVDD}}$	I/O supply current	2-wire, 1/2-swing		30		mA
		4x real decimation, 1-wire		39		
		4x real decimation, 1/2-wire		36		
		16x real decimation, 1-wire		37		
		16x real decimation, 1/2-wire		33		
		4x complex decimation, 1-wire		44		
		16x complex decimation, 1-wire		40		
		16x complex decimation, 1/2-wire		36		
$I_{\text{AVDD}}$	Internal reference, additional analog supply current			3		mA
	External 1.2V reference (REFBUF), additional analog supply current			0.3		
	Single ended clock input, reduces analog supply current by	Enabled via SPI		0.7		
$P_{\text{DIS}}$	Power consumption in global power down mode	Default mask settings, internal reference		5		mW
		Default mask settings, external reference		9		

## 5.6 Electrical Characteristics - DC Specifications

Typical values at  $T_A = 25^\circ\text{C}$ , full temperature range is  $T_{\text{MIN}} = -55^\circ\text{C}$  to  $T_{\text{MAX}} = 105^\circ\text{C}$ , ADC sampling rate = 65 MSPS, 50% clock duty cycle,  $\text{AVDD} = \text{IOVDD} = 1.8\text{ V}$ , 1.6 V external reference, and  $-1\text{-dBFS}$  differential input, unless otherwise noted

PARAMETER		TEST CONDITIONS	MIN	TYP	MAX	UNIT
<b>DC ACCURACY</b>						
No missing codes			18			bits
PSRR		$F_{\text{IN}} = 1\text{ MHz}$		50		dB
DNL	Differential nonlinearity	$F_{\text{IN}} = 5\text{ MHz}$	-1.8	$\pm 0.7$	+1.8	LSB
INL	Integral nonlinearity	$F_{\text{IN}} = 5\text{ MHz}$		$\pm 7$	$\pm 19$	LSB
$V_{\text{OS\_ERR}}$	Offset error			$\pm 130$	$\pm 510$	LSB
$V_{\text{OS\_DRIFT}}$	Offset drift over temperature			$\pm 0.2$		LSB/ $^\circ\text{C}$
$\text{GAIN}_{\text{ERR}}$	Gain error	External 1.6V Reference		$\pm 2.3$		%FSR
$\text{GAIN}_{\text{DRIFT}}$	Gain drift over temperature	External 1.6V Reference		68		ppm/ $^\circ\text{C}$
$\text{GAIN}_{\text{ERR}}$	Gain error	Internal Reference		$\pm 3.5$		%FSR
$\text{GAIN}_{\text{ERR}}$	Gain error	Internal Reference, $F_s = 10\text{ MSPS}$	-2.5	-0.6	+2.5	%FSR
$\text{GAIN}_{\text{DRIFT}}$	Gain drift over temperature	Internal Reference		242		ppm/ $^\circ\text{C}$
Transition Noise	Transition Noise			5		LSB

## 5.6 Electrical Characteristics - DC Specifications (continued)

Typical values at  $T_A = 25^\circ\text{C}$ , full temperature range is  $T_{\text{MIN}} = -55^\circ\text{C}$  to  $T_{\text{MAX}} = 105^\circ\text{C}$ , ADC sampling rate = 65 MSPS, 50% clock duty cycle,  $\text{AVDD} = \text{IOVDD} = 1.8\text{ V}$ , 1.6 V external reference, and  $-1\text{-dBFS}$  differential input, unless otherwise noted

PARAMETER		TEST CONDITIONS	MIN	TYP	MAX	UNIT
<b>ADC ANALOG INPUT (AINP/M, BINP/M)</b>						
FS	Input full scale	Differential		3.2		V <sub>pp</sub>
V <sub>CM</sub>	Input common mode voltage		0.9	0.95	1.0	V
R <sub>IN</sub>	Differential input resistance	F <sub>IN</sub> = 100 kHz		8		kΩ
C <sub>IN</sub>	Differential input Capacitance	F <sub>IN</sub> = 100 kHz		7		pF
V <sub>OCM</sub>	Output common mode voltage			0.95		V
BW	Analog Input Bandwidth (-3dB)			200		MHz
<b>Internal Voltage Reference</b>						
V <sub>REF</sub>	Internal reference voltage			1.6		V
V <sub>REF</sub> Output Impedance				8		Ω
<b>Reference Input Buffer (REFBUF)</b>						
External reference voltage				1.2		V
<b>External voltage reference (VREF)</b>						
V <sub>REF</sub>	External voltage reference			1.6		V
Input Current				0.3		mA
Input impedance				5.3		kΩ
<b>Clock Input (CLKP/M)</b>						
Input clock frequency			1		65	MHz
V <sub>ID</sub>	Differential input voltage		0.5	1	3.6	V <sub>pp</sub>
V <sub>CM</sub>	Input common mode voltage			0.9		V
R <sub>IN</sub>	Single ended input resistance to common mode			5		kΩ
C <sub>IN</sub>	Single ended input capacitance			1.5		pF
Clock duty cycle			40	50	60	%
<b>Digital Inputs (RESET, PDN, SCLK, SEN, SDIO)</b>						
V <sub>IH</sub>	High level input voltage		1.4			V
V <sub>IL</sub>	Low level input voltage				0.4	V
I <sub>IH</sub>	High level input current			90	150	μA
I <sub>IL</sub>	Low level input current		-150	-90		μA
C <sub>i</sub>	Input capacitance			1.5		pF
<b>Digital Output (SDOUT)</b>						
V <sub>OH</sub>	High level output voltage	I <sub>LOAD</sub> = -400 μA	IOVDD - 0.1	IOVDD		V
V <sub>OL</sub>	Low level output voltage	I <sub>LOAD</sub> = 400 μA			0.1	V
<b>SLVDS Interface</b>						
Output data rate		per differential SLVDS output pair			1000	Mbps
V <sub>ID</sub>	Differential input voltage	DCLKIN	200	350	650	mV <sub>pp</sub>
V <sub>CM</sub>	Input common mode voltage		1	1.2	1.3	V
V <sub>OD</sub>	Differential output voltage		500	700	850	mV <sub>pp</sub>
V <sub>CM</sub>	Output common mode voltage			1.0		V

## 5.7 Electrical Characteristics - AC Specifications

Typical values at  $T_A = 25^\circ\text{C}$ , full temperature range is  $T_{\text{MIN}} = -55^\circ\text{C}$  to  $T_{\text{MAX}} = 105^\circ\text{C}$ , ADC sampling rate = 65 MSPS, 50% clock duty cycle,  $\text{AVDD} = \text{IOVDD} = 1.8\text{ V}$ , 1.6 V external reference, and  $-1\text{-dBFS}$  differential input, unless otherwise noted

PARAMETER		TEST CONDITIONS	MIN	TYP	MAX	UNIT
<b>ADC3683-SEP 65 MSPS:</b>						
NSD	Noise Spectral Density	$f_{\text{IN}} = 1.1\text{ MHz}$ , $A_{\text{IN}} = -20\text{ dBFS}$		-160		dBFS/Hz
SNR	Signal to noise ratio	$f_{\text{IN}} = 1.1\text{ MHz}$ , $A_{\text{IN}} = -20\text{ dBFS}$		84.8		dBFS
		$f_{\text{IN}} = 1.1\text{ MHz}$		84.2		
		$f_{\text{IN}} = 5\text{ MHz}$	81.0	83.8		
		$f_{\text{IN}} = 10\text{ MHz}$		83.6		
		$f_{\text{IN}} = 20\text{ MHz}$		82.6		
		$f_{\text{IN}} = 40\text{ MHz}$		81.0		
		$f_{\text{IN}} = 70\text{ MHz}$		77.3		
SINAD	Signal to noise and distortion ratio	$f_{\text{IN}} = 1.1\text{ MHz}$		80.0		dBFS
		$f_{\text{IN}} = 5\text{ MHz}$		82.7		
		$f_{\text{IN}} = 10\text{ MHz}$		82.7		
		$f_{\text{IN}} = 20\text{ MHz}$		80.2		
		$f_{\text{IN}} = 40\text{ MHz}$		78.7		
		$f_{\text{IN}} = 70\text{ MHz}$		75.8		
ENOB	Effective number of bits	$f_{\text{IN}} = 1.1\text{ MHz}$		13.7		bits
		$f_{\text{IN}} = 5\text{ MHz}$		13.6		
		$f_{\text{IN}} = 10\text{ MHz}$		13.6		
		$f_{\text{IN}} = 20\text{ MHz}$		13.4		
		$f_{\text{IN}} = 40\text{ MHz}$		13.2		
		$f_{\text{IN}} = 70\text{ MHz}$		12.5		
THD	Total Harmonic Distortion (First five harmonics)	$f_{\text{IN}} = 1.1\text{ MHz}$		81		dBc
		$f_{\text{IN}} = 5\text{ MHz}$	80.5	88		
		$f_{\text{IN}} = 10\text{ MHz}$		89		
		$f_{\text{IN}} = 20\text{ MHz}$		83		
		$f_{\text{IN}} = 40\text{ MHz}$		82		
		$f_{\text{IN}} = 70\text{ MHz}$		80		
SFDR	Spur free dynamic range including second and third harmonic distortion	$f_{\text{IN}} = 1.1\text{ MHz}$		82		dBc
		$f_{\text{IN}} = 5\text{ MHz}$	81.5	89		
		$f_{\text{IN}} = 10\text{ MHz}$		92		
		$f_{\text{IN}} = 20\text{ MHz}$		85		
		$f_{\text{IN}} = 40\text{ MHz}$		84		
		$f_{\text{IN}} = 70\text{ MHz}$		82		
Non HD2,3	Spur free dynamic range (excluding HD2 and HD3)	$f_{\text{IN}} = 1.1\text{ MHz}$		101		dBFS
		$f_{\text{IN}} = 5\text{ MHz}$	90	101		
		$f_{\text{IN}} = 10\text{ MHz}$		100		
		$f_{\text{IN}} = 20\text{ MHz}$		97		
		$f_{\text{IN}} = 40\text{ MHz}$		91		
		$f_{\text{IN}} = 70\text{ MHz}$		88		
IMD3	Two tone inter-modulation distortion	$f_1 = 10\text{ MHz}$ , $f_2 = 12\text{ MHz}$ , $A_{\text{IN}} = -7\text{ dBFS/ tone}$		89		dBc
		$f_1 = 40\text{ MHz}$ , $f_2 = 45\text{ MHz}$ , $A_{\text{IN}} = -7\text{ dBFS/ tone}$		84		

## 5.8 Timing Requirements

Typical values at  $T_A = 25^\circ\text{C}$ , MIN and MAX timing values are characterized over the full temperature range  $T_{\text{MIN}} = -55^\circ\text{C}$  to  $T_{\text{MAX}} = 105^\circ\text{C}$  and are NOT production tested, ADC sampling rate = 65 MSPS, 50% clock duty cycle, AVDD = IOVDD = 1.8 V, 1.6 V external reference, and -1-dBFS differential input, unless otherwise noted

PARAMETER		TEST CONDITIONS	MIN	NOM	MAX	UNIT
<b>ADC Timing Specifications</b>						
$t_{\text{AD}}$	Aperture Delay			0.85		ns
$t_{\text{A}}$	Aperture Jitter	Square wave clock with fast edges		180		fs
$t_{\text{J}}$	Jitter on DCLKIN				$\pm 50$	ps
$t_{\text{ACQ}}$	Signal acquisition period, referenced to sampling clock falling edge	$F_S = 10 \text{ Msps}$		$-T_S/2$		Sampling Clock Period
		$F_S = 25 \text{ Msps}$		$-T_S/2$		
		$F_S = 65 \text{ Msps}$		$-T_S/4$		
$t_{\text{CONV}}$	Signal conversion period, referenced to sampling clock falling edge	$F_S = 10 \text{ Msps}$		$+T_S \times 1/5$		Sampling Clock Period
		$F_S = 25 \text{ Msps}$		$+T_S \times 3/8$		
		$F_S = 65 \text{ Msps}$		$+T_S \times 5/8$		
Wake up time	Time to valid data after coming out of power down. Internal reference.	Bandgap reference enabled, single ended clock			17.6	us
		Bandgap reference enabled, differential clock			12.9	
		Bandgap reference disabled, single ended clock			2.2	ms
		Bandgap reference disabled, differential clock			2.2	
	Time to valid data after coming out of power down. External 1.6V reference.	Bandgap reference enabled, single ended clock			15.9	us
		Bandgap reference enabled, differential clock			12.9	
		Bandgap reference disabled, single ended clock			1.7	ms
		Bandgap reference disabled, differential clock			1.7	
$t_{\text{S,SYNC}}$	Setup time for SYNC input signal	Referenced to sampling clock rising edge	500			ps
$t_{\text{H,SYNC}}$	Hold time for SYNC input signal		600			
ADC Latency	Signal input to data output	SLVDS 2-wire		2		ADC clock cycles
		SLVDS 1-wire		1		
ADC Latency	Signal input to data output	SLVDS 2-wire		2		ADC clock cycles
		SLVDS 1-wire		1		
		SLVDS 1/2-wire		1		
Add Latency	Real decimation by 2			21		Output clock cycles
	Complex decimation by 2			22		
	Real or complex decimation by 4, 8, 16, 32			23		

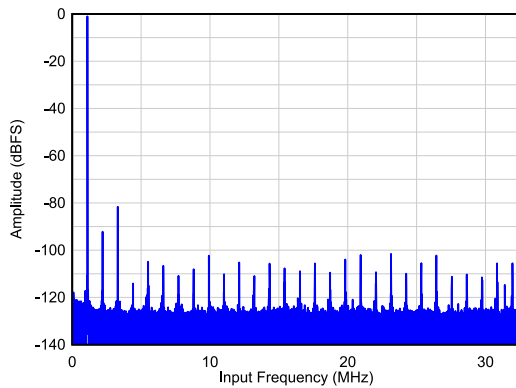
## 5.8 Timing Requirements (continued)

Typical values at  $T_A = 25^\circ\text{C}$ , MIN and MAX timing values are characterized over the full temperature range  $T_{\text{MIN}} = -55^\circ\text{C}$  to  $T_{\text{MAX}} = 105^\circ\text{C}$  and are NOT production tested, ADC sampling rate = 65 MSPS, 50% clock duty cycle, AVDD = IOVDD = 1.8 V, 1.6 V external reference, and -1-dBFS differential input, unless otherwise noted

PARAMETER		TEST CONDITIONS	MIN	NOM	MAX	UNIT
<b>Interface Timing: Serial LVDS Interface</b>						
$t_{\text{PD}}$	Propagation delay: sampling clock falling edge to DCLK rising edge	Delay between sampling clock falling edge to DCLKIN falling edge < 2.5ns. $T_{\text{DCLK}} = \text{DCLK period}$ $t_{\text{CDCLK}} = \text{Sampling clock falling edge to DCLKIN falling edge}$	$2 + t_{\text{CDCLK}}$	$3 + t_{\text{CDCLK}}$	$4 + t_{\text{CDCLK}}$	ns
		Delay between sampling clock falling edge to DCLKIN falling edge $\geq 2.5\text{ns}$ . $T_{\text{DCLK}} = \text{DCLK period}$ $t_{\text{CDCLK}} = \text{Sampling clock falling edge to DCLKIN falling edge}$	$t_{\text{CDCLK}}$	$t_{\text{CDCLK}}$	$t_{\text{CDCLK}}$	ns
$t_{\text{CD}}$	DCLK rising edge to output data delay, 2-wire SLVDS	Fout = 10 MSPS, DA/B0,1 = 90 MBPS	0	0.1		ns
		Fout = 25 MSPS, DA/B0,1 = 225 MBPS	0	0.1		
		Fout = 65 MSPS, DA/B0,1 = 585 MBPS	0	0.1		
	DCLK rising edge to output data delay, 1-wire SLVDS	Fout = 10 MSPS, DA/B0 = 180 MBPS	0.1	0.2		
		Fout = 25 MSPS, DA/B0 = 450 MBPS	0	0.1		
		Fout = 55 MSPS, DA/B0 = 990 MBPS	-0.4	0.1		
DCLK rising edge to output data delay, 1/2-wire SLVDS	Fout = 5 MSPS, DA0 = 180 MBPS	0	0.1			
	Fout = 10 MSPS, DA0 = 360 MBPS	0	0.1			
	Fout = 25 MSPS, DA0 = 720 MBPS	0	0.1			
$t_{\text{DV}}$	Data valid, 2-wire SLVDS	Fout = 10 MSPS, DA/B0,1 = 90 MBPS	10.5	10.7		ns
		Fout = 25 MSPS, DA/B0,1 = 225 MBPS	4.0	4.1		
		Fout = 65 MSPS, DA/B0,1 = 585 MBPS	1.3	1.4		
	Data valid, 1-wire SLVDS	Fout = 10 MSPS, DA/B0 = 180 MBPS	4.7	4.8		
		Fout = 25 MSPS, DA/B0 = 450 MBPS	1.8	1.9		
		Fout = 55 MSPS, DA/B0 = 990 MBPS	0.5	0.6		
	Data valid, 1/2-wire SLVDS	Fout = 5 MSPS, DA0 = 180 MBPS	4.7	4.8		
		Fout = 10 MSPS, DA0 = 360 MBPS	2.4	2.5		
		Fout = 25 MSPS, DA0 = 900 MBPS	0.6	0.7		
<b>SERIAL PROGRAMMING INTERFACE (SCLK, SEN, SDIO) - Input</b>						
$f_{\text{CLK(SCLK)}}$	Serial clock frequency			20		MHz
$t_{\text{SU(SEN)}}$	SEN to rising edge of SCLK		10			ns
$t_{\text{H(SEN)}}$	SEN from rising edge of SCLK		9			ns
$t_{\text{SU(SDIO)}}$	SDIO to rising edge of SCLK		17			ns
$t_{\text{H(SDIO)}}$	SDIO from rising edge of SCLK		9			ns
<b>SERIAL PROGRAMMING INTERFACE (SDIO) - Output</b>						
$t_{\text{(OZD)}}$	SDIO tri-state to driven		3.9		10.8	ns
$t_{\text{(ODZ)}}$	SDIO data to tri-state		3.4		14	ns
$t_{\text{(OD)}}$	SDIO valid from falling edge of SCLK		3.9		10.8	ns

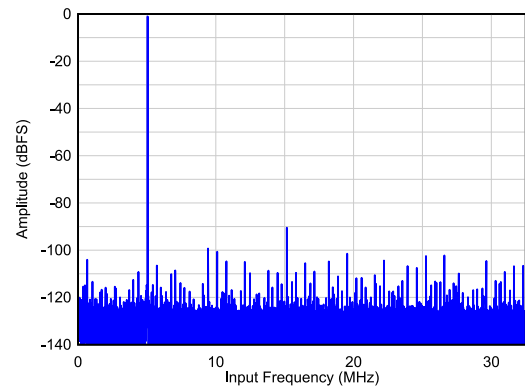
## 5.9 Typical Characteristics - ADC3683

Typical values at  $T_A = 25\text{ }^\circ\text{C}$ , ADC sampling rate = 65MSPS,  $A_{IN} = -1\text{dBFS}$  differential input,  $AVDD = IOVDD = 1.8\text{V}$ , external 1.6V voltage reference, unless otherwise noted.



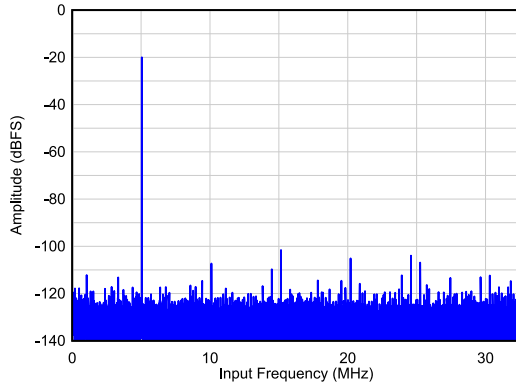
SNR = 84.2dBFS, SFDR = 81dBc, Non HD23 = 101dBFS

**Figure 5-1. Single Tone FFT at  $F_{IN} = 1\text{ MHz}$**



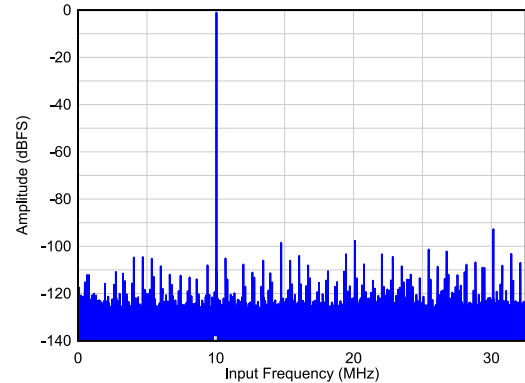
SNR = 83.8dBFS, SFDR = 89dBc, Non HD23 = 99dBFS

**Figure 5-2. Single Tone FFT at  $F_{IN} = 5\text{ MHz}$**



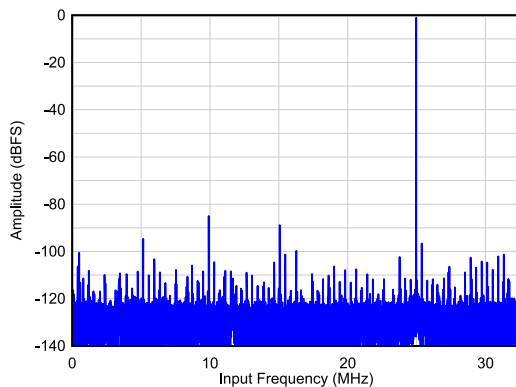
SNR = 84.8dBFS, SFDR = 81dBc, Non HD23 = 103dBFS

**Figure 5-3. Single Tone FFT at  $F_{IN} = 5\text{ MHz}$ ,  $A_{IN} = -20\text{ dBFS}$**



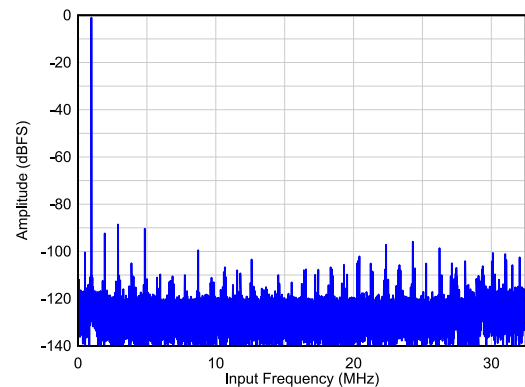
SNR = 83.8dBFS, SFDR = 92dBc, Non HD23 = 98dBFS

**Figure 5-4. Single Tone FFT at  $F_{IN} = 10\text{ MHz}$**



SNR = 81.1dBFS, SFDR = 84dBc, Non HD23 = 95dBFS

**Figure 5-5. Single Tone FFT at  $F_{IN} = 40\text{ MHz}$**

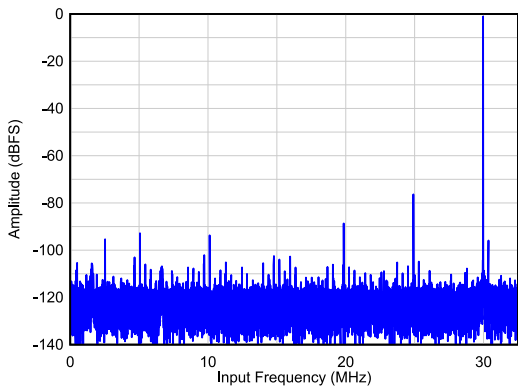


SNR = 77.3dBFS, SFDR = 86dBc, Non HD23 = 92dBFS

**Figure 5-6. Single Tone FFT at  $F_{IN} = 64\text{ MHz}$**

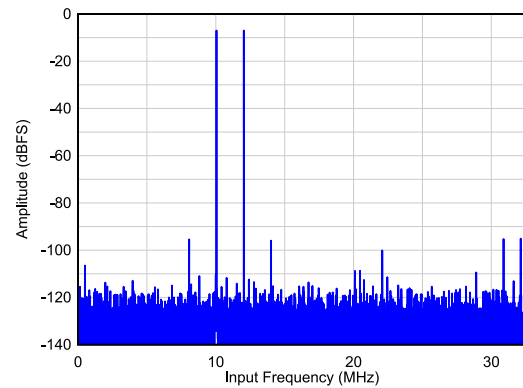
### 5.9 Typical Characteristics - ADC3683 (continued)

Typical values at  $T_A = 25\text{ }^\circ\text{C}$ , ADC sampling rate = 65MSPS,  $A_{IN} = -1\text{dBFS}$  differential input,  $AVDD = IOVDD = 1.8\text{V}$ , external 1.6V voltage reference, unless otherwise noted.



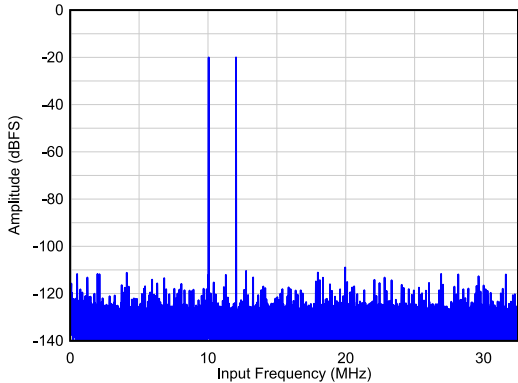
SNR = 75.1dBFS, SFDR = 75dBc, Non HD23 = 93dBFS

**Figure 5-7. Single Tone FFT at  $F_{IN} = 100\text{MHz}$**



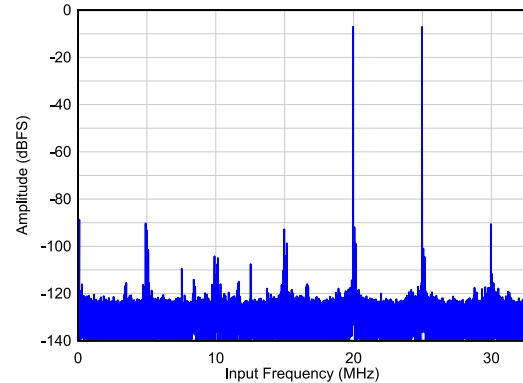
$A_{IN} = -7\text{dBFS}/\text{tone}$ , IMD3 = 88dBc

**Figure 5-8. Two Tone FFT at  $F_{IN} = 10/12\text{MHz}$**



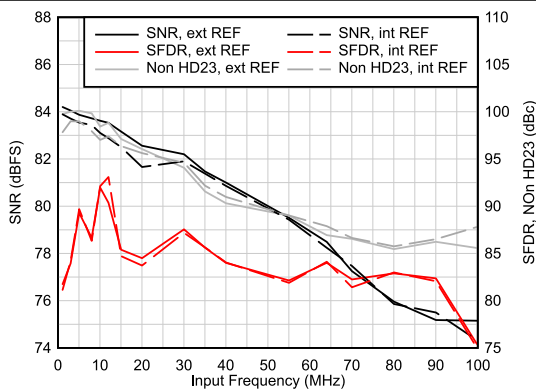
$A_{IN} = -20\text{dBFS}/\text{tone}$ , IMD3 = 95dBc

**Figure 5-9. Two Tone FFT at  $F_{IN} = 10/12\text{MHz}$**

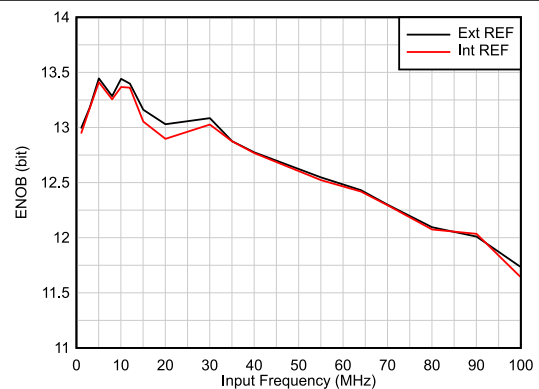


$A_{IN} = -7\text{dBFS}/\text{tone}$ , IMD3 = 83dBc

**Figure 5-10. Two Tone FFT at  $F_{IN} = 40/45\text{MHz}$**



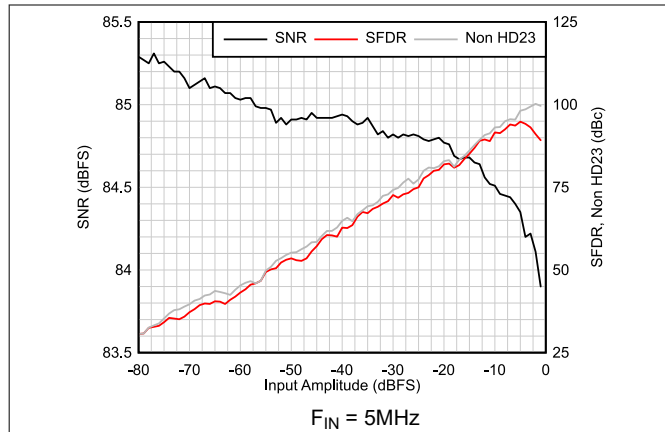
**Figure 5-11. AC Performance vs Input Frequency**



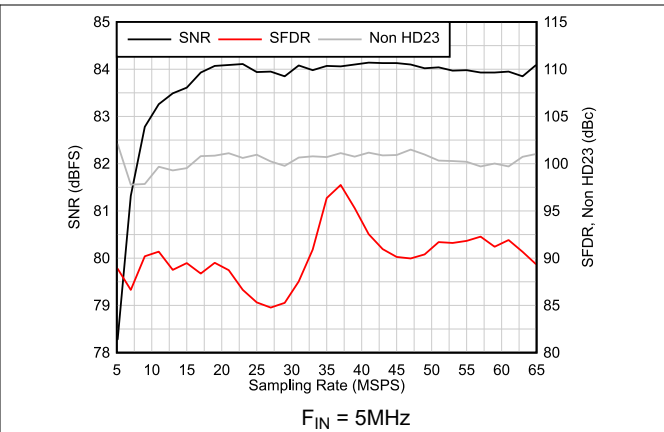
**Figure 5-12. ENOB vs Input Frequency**

## 5.9 Typical Characteristics - ADC3683 (continued)

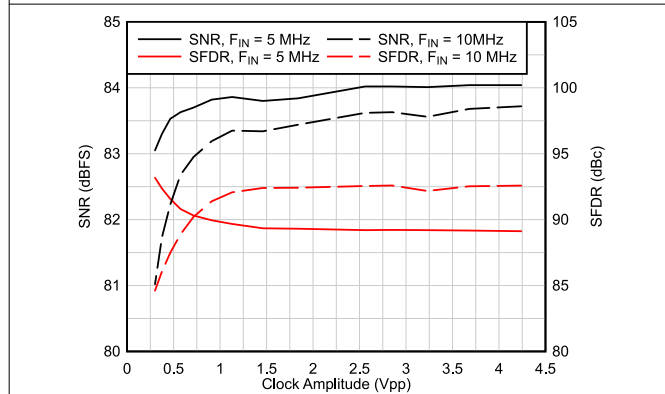
Typical values at  $T_A = 25^\circ\text{C}$ , ADC sampling rate = 65MSPS,  $A_{IN} = -1\text{dBFS}$  differential input,  $AVDD = IOVDD = 1.8\text{V}$ , external  $1.6\text{V}$  voltage reference, unless otherwise noted.



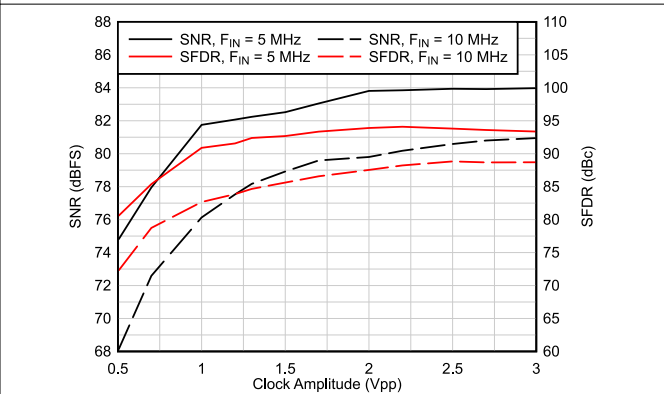
**Figure 5-13. AC Performance vs Input Amplitude**



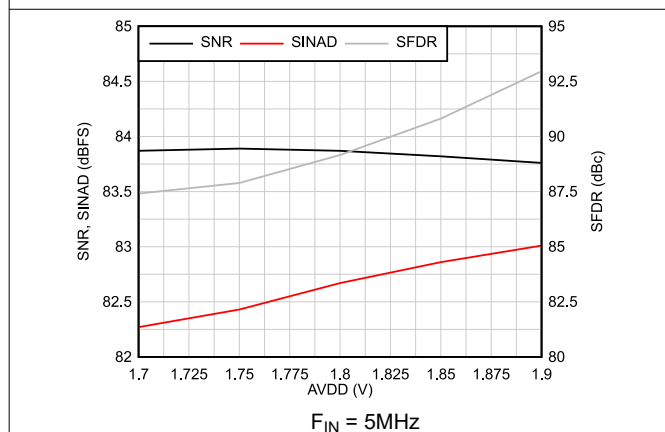
**Figure 5-14. AC Performance vs Sampling Rate**



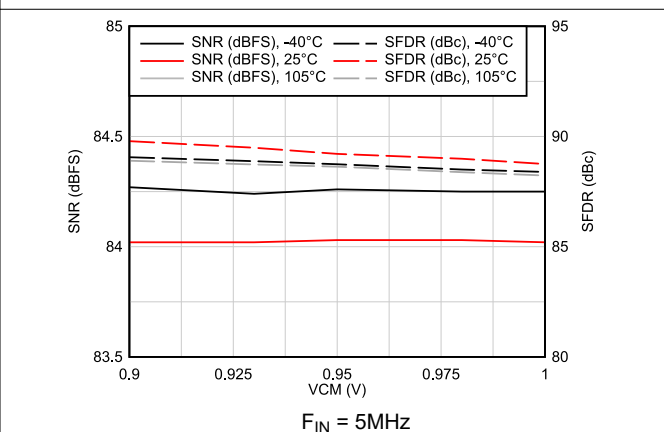
**Figure 5-15. AC Performance vs Clock Amplitude**



**Figure 5-16. AC Performance vs Clock Amplitude**



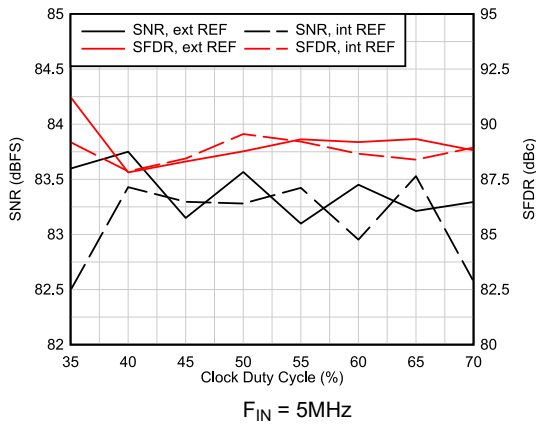
**Figure 5-17. AC Performance vs AVDD**



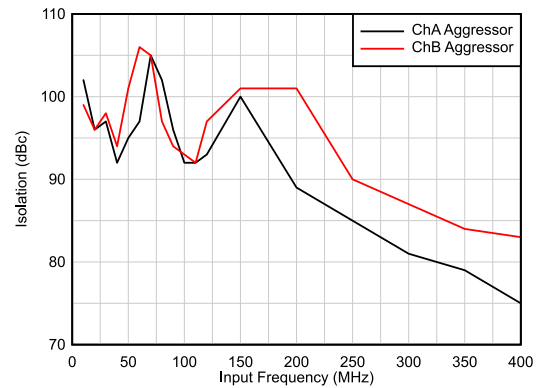
**Figure 5-18. AC Performance vs VCM vs Temperature**

### 5.9 Typical Characteristics - ADC3683 (continued)

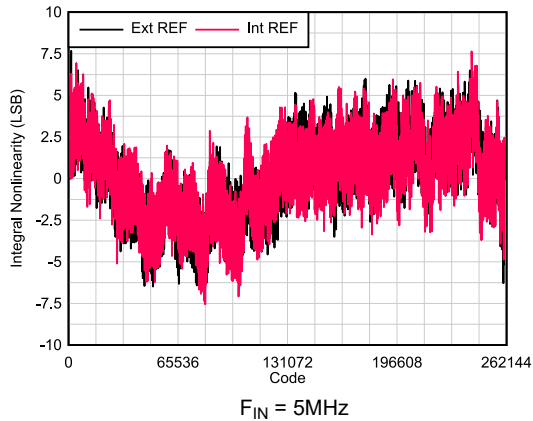
Typical values at  $T_A = 25\text{ }^\circ\text{C}$ , ADC sampling rate = 65MSPS,  $A_{IN} = -1\text{ dBFS}$  differential input,  $AVDD = IOVDD = 1.8\text{V}$ , external 1.6V voltage reference, unless otherwise noted.



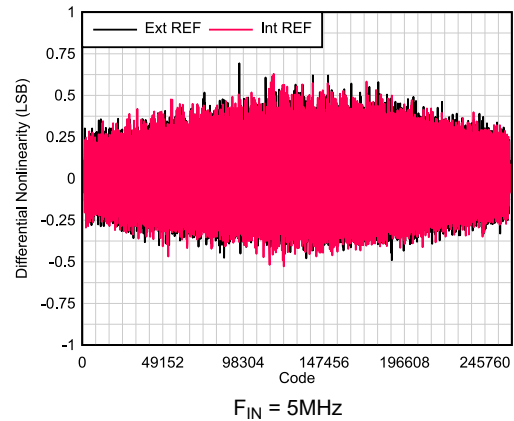
**Figure 5-19. AC Performance vs Clock Duty Cycle**



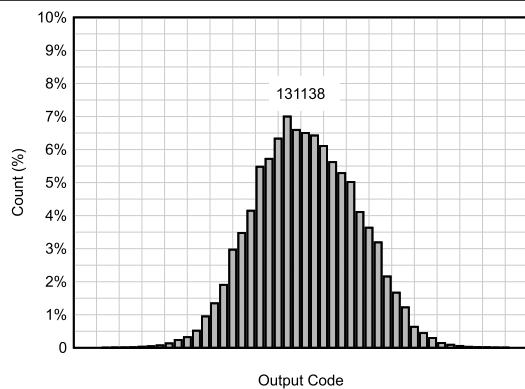
**Figure 5-20. Isolation vs Input Frequency**



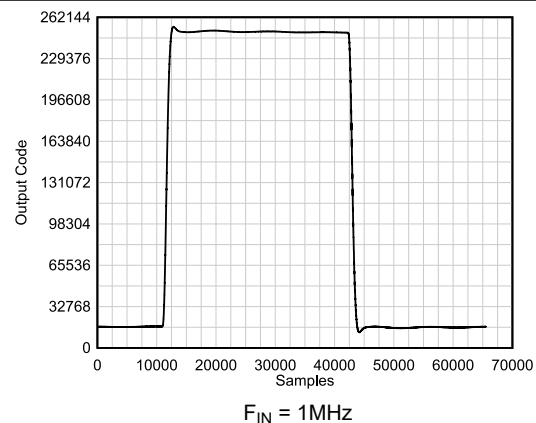
**Figure 5-21. INL vs Code**



**Figure 5-22. DNL vs Code**



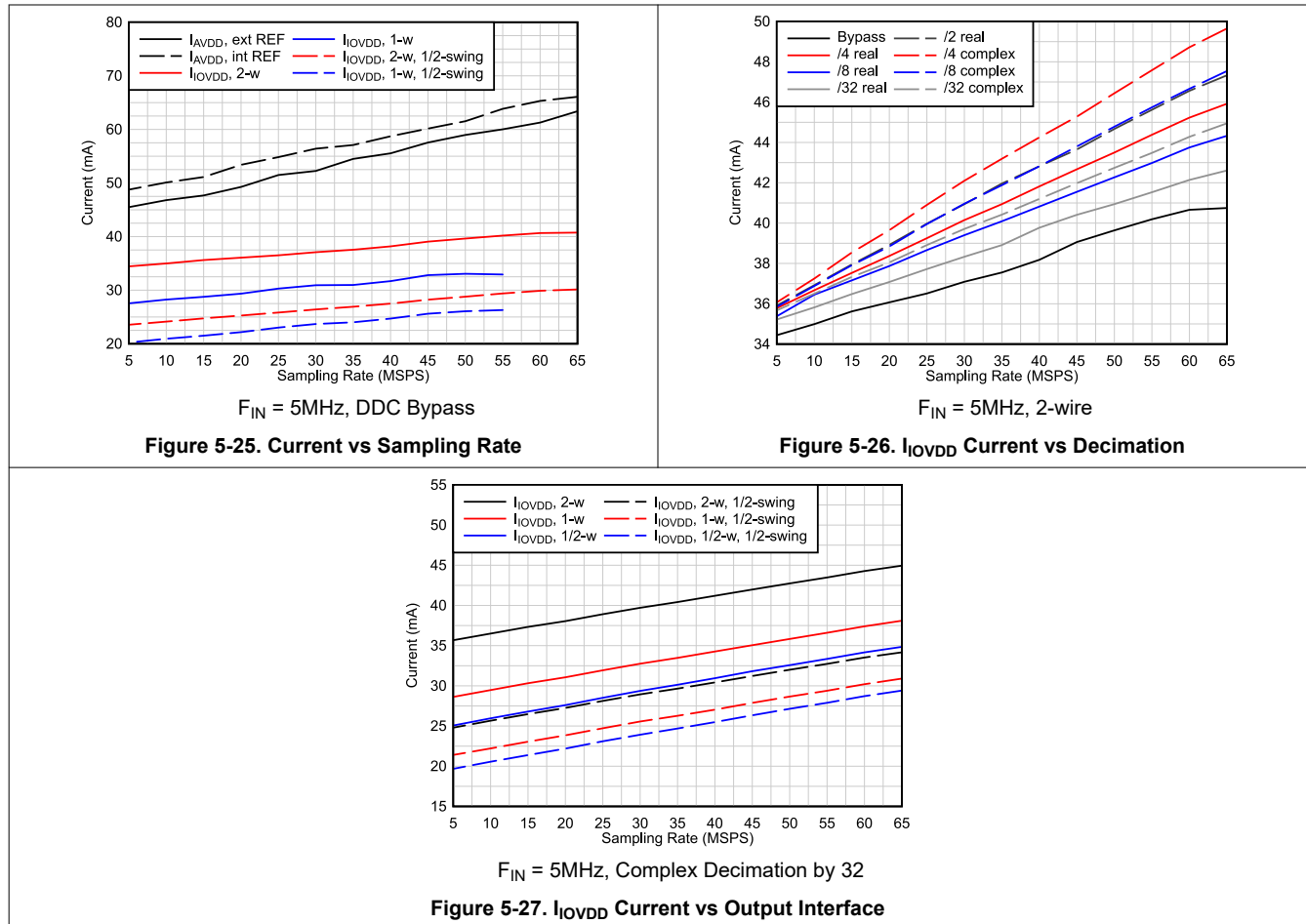
**Figure 5-23. DC Offset Histogram**



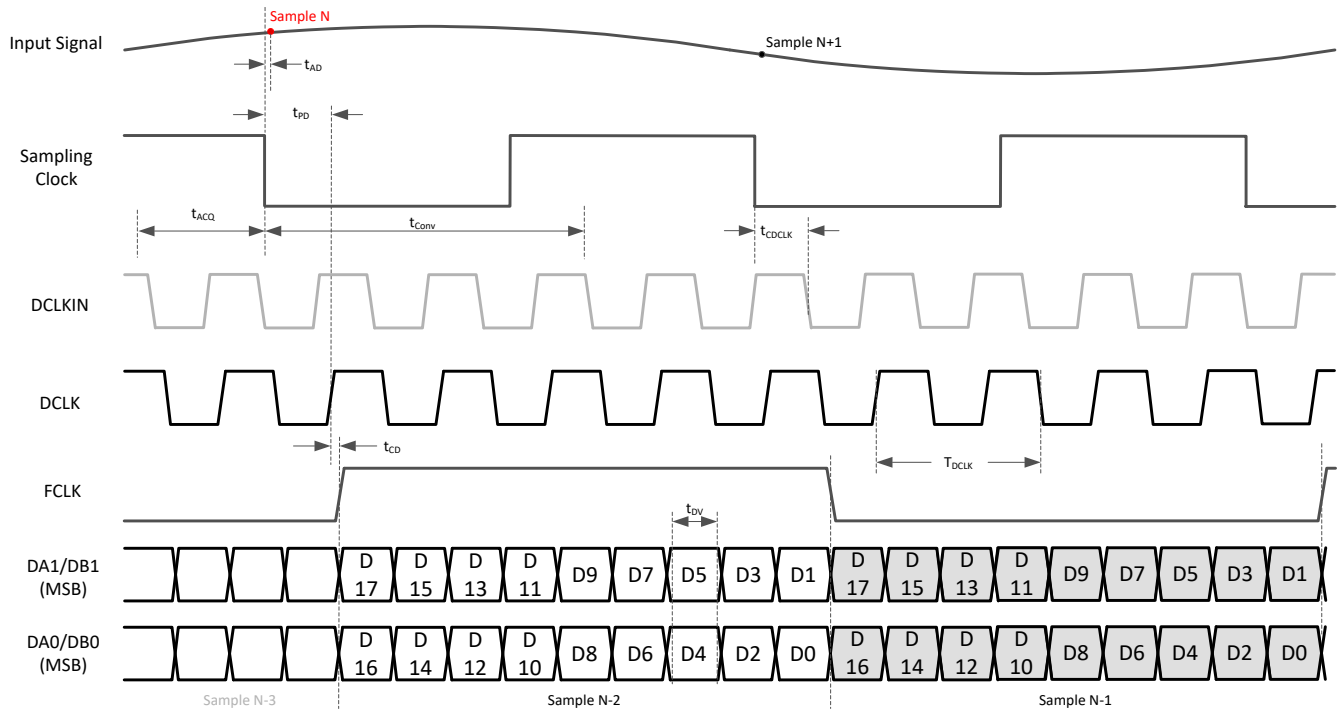
**Figure 5-24. Pulse Response**

### 5.9 Typical Characteristics - ADC3683 (continued)

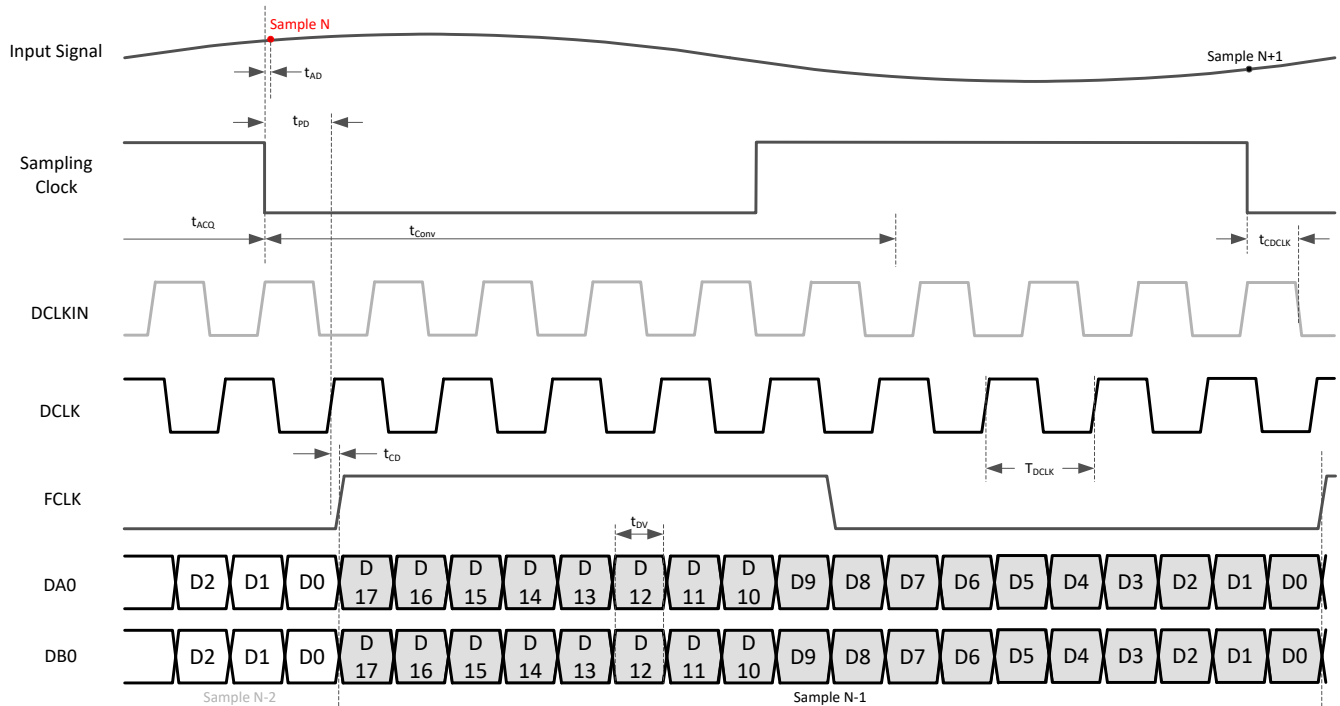
Typical values at  $T_A = 25\text{ }^\circ\text{C}$ , ADC sampling rate = 65MSPS,  $A_{IN} = -1\text{dBFS}$  differential input,  $AVDD = IOVDD = 1.8\text{V}$ , external 1.6V voltage reference, unless otherwise noted.



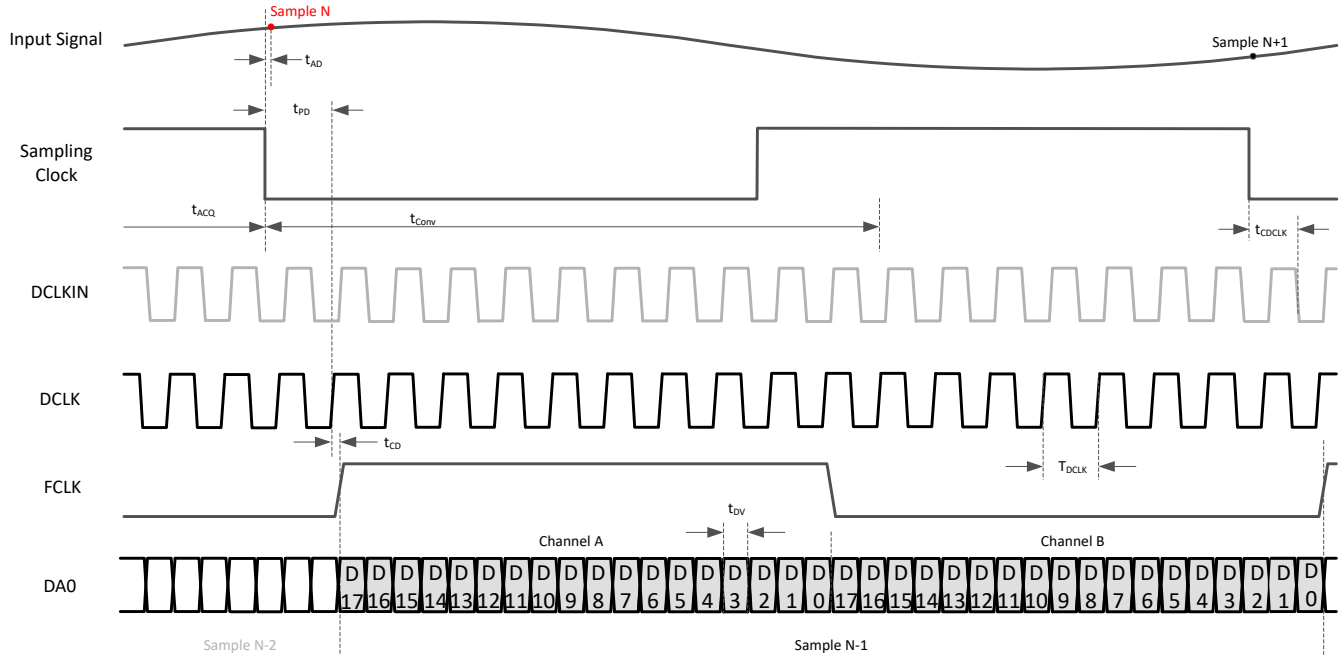
## 6 Parameter Measurement Information



**Figure 6-1. Timing diagram: 2-wire SLVDS (default output bit mapping)**



**Figure 6-2. Timing diagram: 1-wire SLVDS (default output bit mapping)**



**Figure 6-3. Timing diagram: 1/2-wire SLVDS (default output bit mapping)**

## 7 Detailed Description

### 7.1 Overview

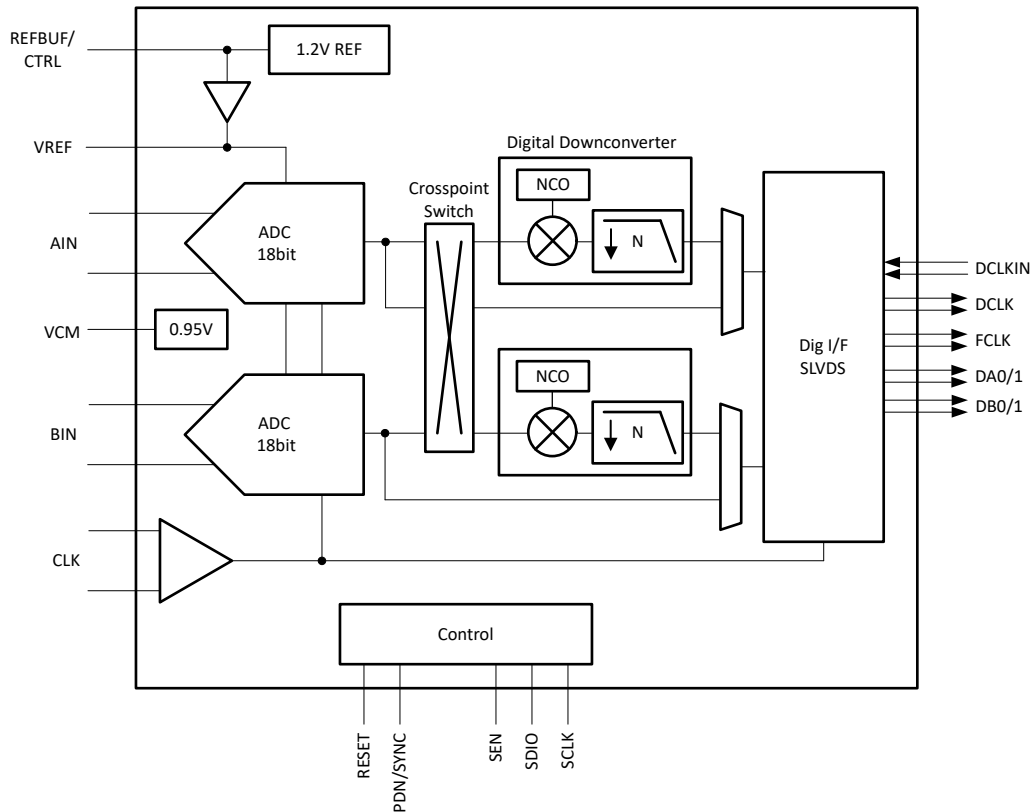
The ADC3683-xEP is a low noise, ultra-low power 18-bit high-speed dual channel ADC family supporting sampling rates up to 65 MSPS. The device offers DC precision together with IF sampling support. Making the device designed for a wide range of applications. The ADC3683-xEP is equipped with an internal reference option but it also supports the use of an external, high precision 1.6V voltage reference or an external 1.2V reference which is buffered and gained up internally. Because of the inherent low latency architecture, the digital output result is available after only one or two clock cycles depending on the digital output interface.

An optional programmable digital down converter enables external anti-alias filter relaxation as well as output data rate reduction. The digital filter provides a 32-bit programmable NCO and supports both real or complex decimation.

The ADC3683-xEP uses a serial LVDS (SLVDS) interface to output the data which minimizes the number of digital interconnects. The device supports a two-lane (2-wire), a one-lane (1-wire) and a half-lane (1/2-wire) option. The ADC3683-xEP includes a digital output formatter which supports output resolutions from 14 to 20-bit.

The device features and control options are set up either through pin configurations or via SPI register writes.

### 7.2 Functional Block Diagram

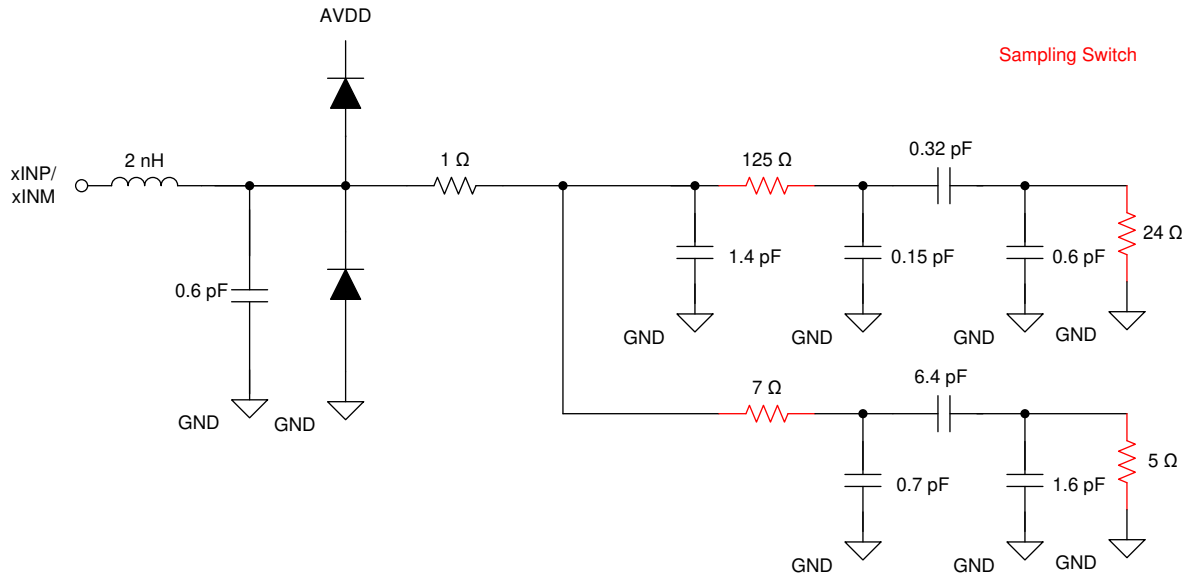


## 7.3 Feature Description

### 7.3.1 Analog Input

The analog inputs of ADC3683-xEP are intended to be driven differentially. Both AC coupling and DC coupling of the analog inputs is supported. The analog inputs are designed for an input common mode voltage of 0.95V which must be provided externally on each input pin. DC-coupled input signals must have a common mode voltage that meets the device input common mode voltage range.

The equivalent input network diagram is shown in Figure 7-1. All four sampling switches, on-resistance shown in red are in same position (open or closed) simultaneously.

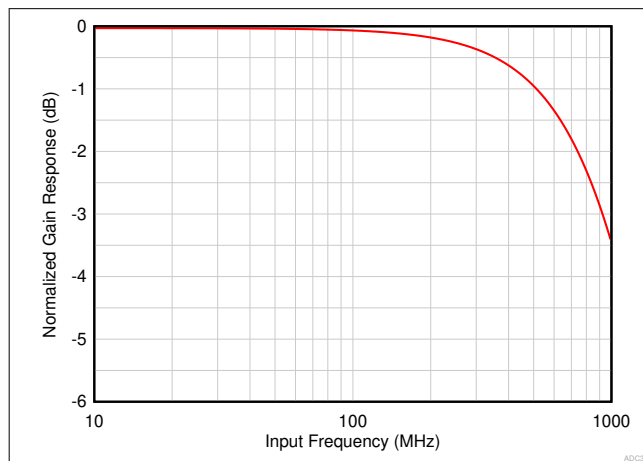


**Figure 7-1. Equivalent input network**

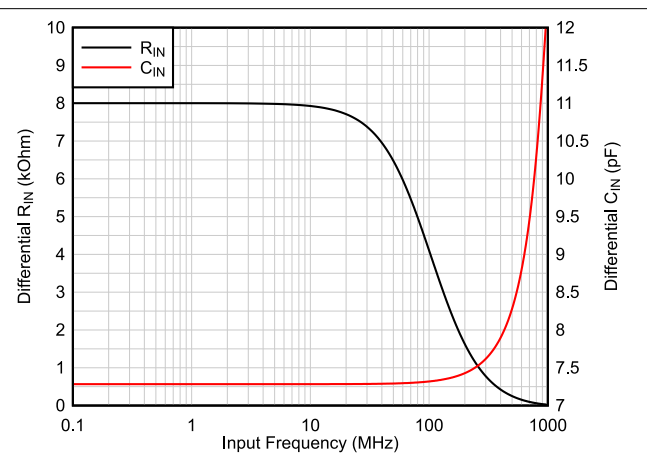
#### 7.3.1.1 Analog Input Bandwidth

Figure 7-2 shows the analog full power input bandwidth of the ADC3683-xEP with a 50Ω differential termination. The -3dB bandwidth is approximately 900MHz and the useful input bandwidth with good AC performance is approximately 120MHz.

The equivalent differential input resistance  $R_{IN}$  and input capacitance  $C_{IN}$  vs frequency are shown in Figure 7-3.



**Figure 7-2. ADC Analog Input bandwidth response**



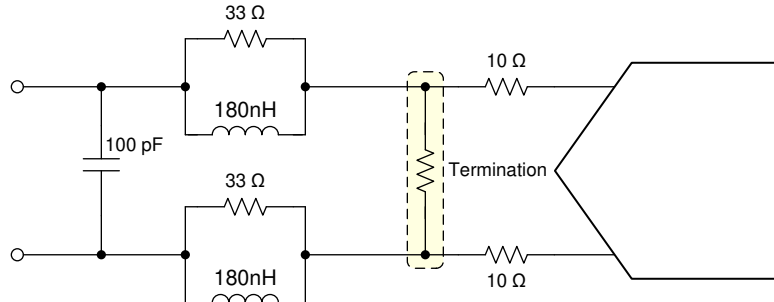
**Figure 7-3. Equivalent  $R_{IN}$ ,  $C_{IN}$  vs Input Frequency**

### 7.3.1.2 Analog Front End Design

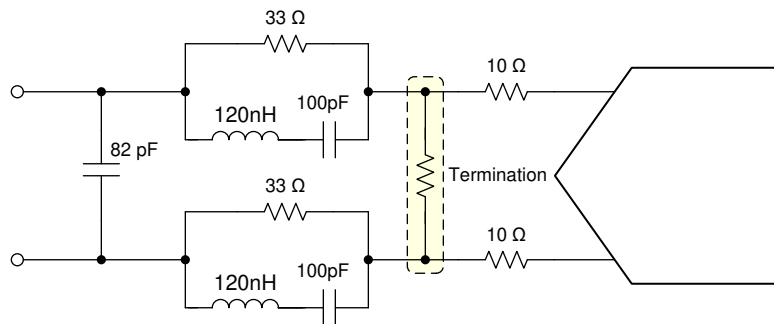
The ADC3683-xEP is an unbuffered ADC and thus a passive kick-back filter is recommended to absorb the glitch from the sampling operation. Depending on if the input is driven by a balun or a differential amplifier with low output impedance, a termination network is needed. Additionally, a passive DC bias circuit is needed in AC-coupled applications which is combined with the termination network.

#### 7.3.1.2.1 Sampling Glitch Filter Design

The front end sampling glitch filter is designed to optimize the SNR and HD3 performance of the ADC. The filter performance is dependent on input frequency; therefore, the following filter designs are recommended for different input frequency ranges as shown in Figure 7-4 and Figure 7-5 (assuming a 50Ω source impedance).



**Figure 7-4. Sampling glitch filter example for input frequencies from DC to 30MHz**



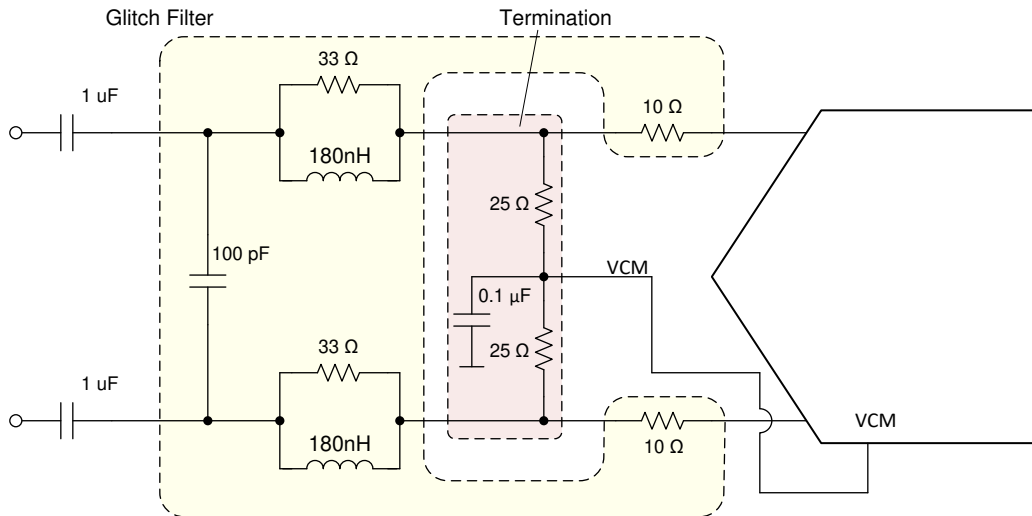
**Figure 7-5. Sampling glitch filter example for input frequencies from 30 to 70MHz**

### 7.3.1.2.2 Analog Input Termination and DC Bias

Depending on the input drive circuitry, a termination network and/or DC biasing needs to be provided.

#### 7.3.1.2.2.1 AC-Coupling

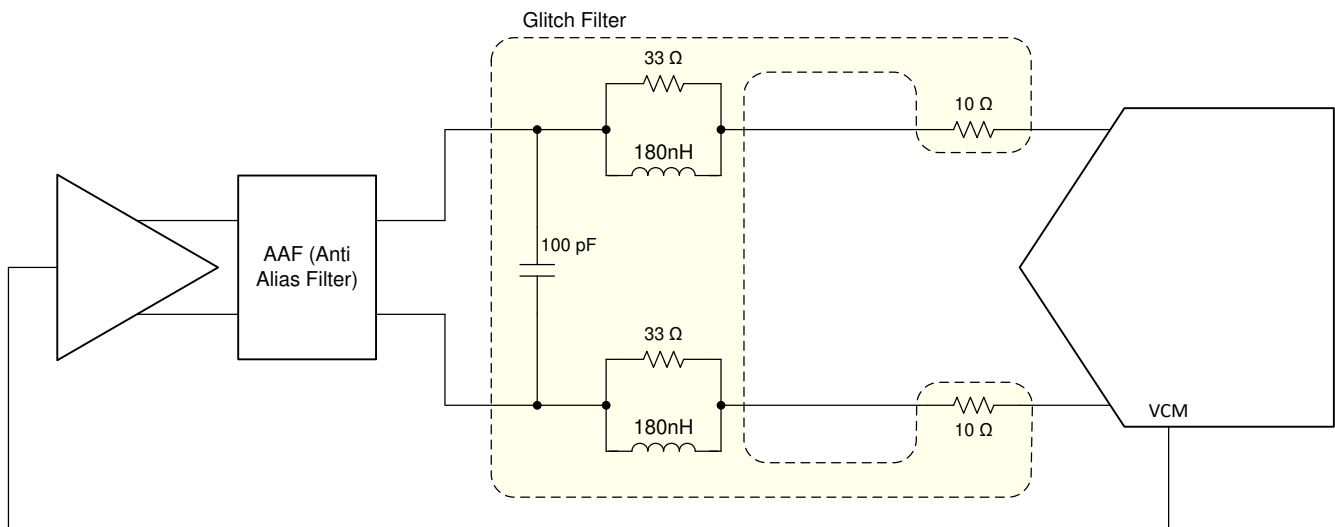
The ADC3683-xEP requires external DC bias using the common mode output voltage (VCM) of the ADC together with the termination network as shown in Figure 7-6. The termination is located within the glitch filter network. When using a balun on the input, the termination impedance has to be adjusted to account for the turns ratio of the transformer. When using an amplifier, the termination impedance is adjusted to optimize the amplifier performance.



**Figure 7-6. AC-Coupling: termination network provides DC bias (glitch filter example for DC - 30 MHz)**

#### 7.3.1.2.2.2 DC-Coupling

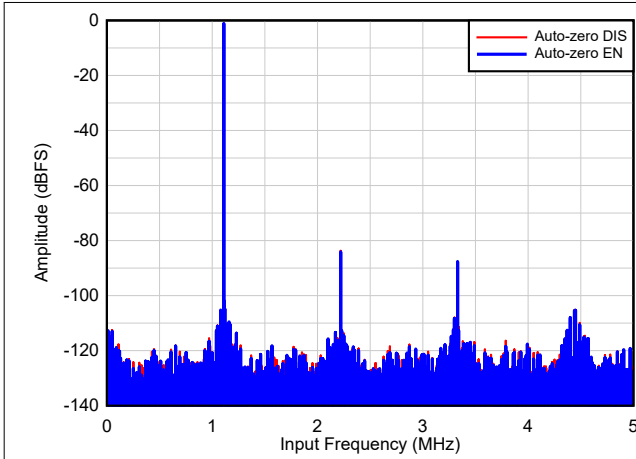
In DC coupled applications, the DC bias needs to be provided from the fully differential amplifier (FDA) using VCM output of the ADC as shown in Figure 7-7. The glitch filter, in this case, is located between the anti-alias filter and the ADC. No termination is needed if the amplifier is located close to the ADC, or if the termination is part of the anti-alias filter.



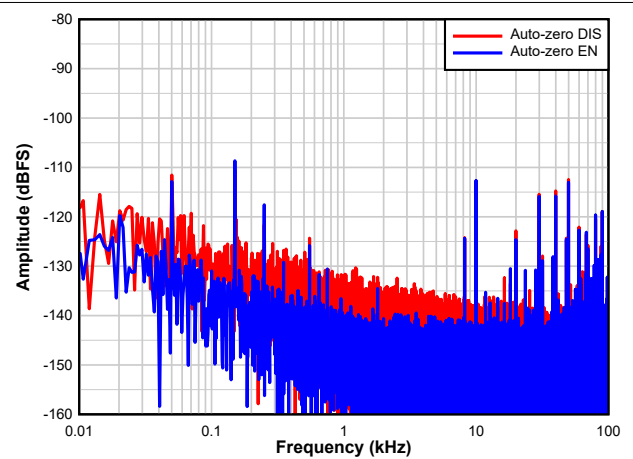
**Figure 7-7. DC-Coupling: DC bias provided by FDA (glitch filter example for DC - 30MHz)**

### 7.3.1.3 Auto-Zero Feature

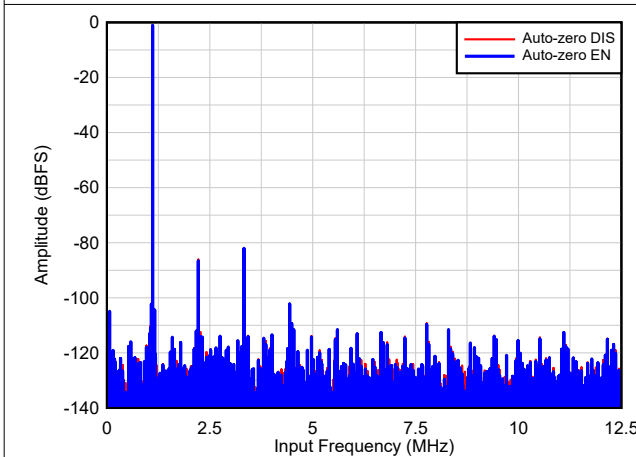
The ADC3683-xEP includes an internal auto-zero front end amplifier circuit which improves the 1/f flicker noise. The auto-zero feature is enabled using SPI register writes for the device (register 0x11, D0). The 4M point FFTs below shows the autozero feature enabled vs disabled.



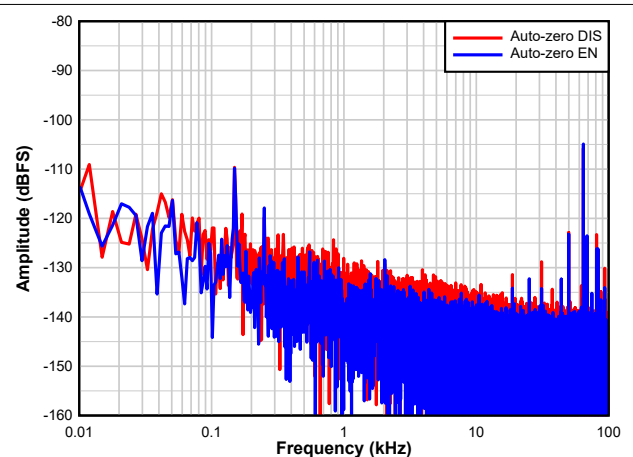
**Figure 7-8.  $F_S = 10\text{MSPS}$ ,  $F_{IN} = 1.1\text{MHz}$**



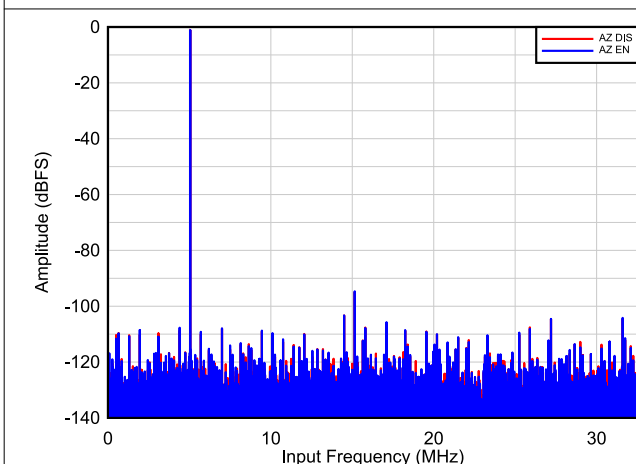
**Figure 7-9.  $F_S = 10\text{MSPS}$ ,  $F_{IN} = 1.1\text{MHz}$**



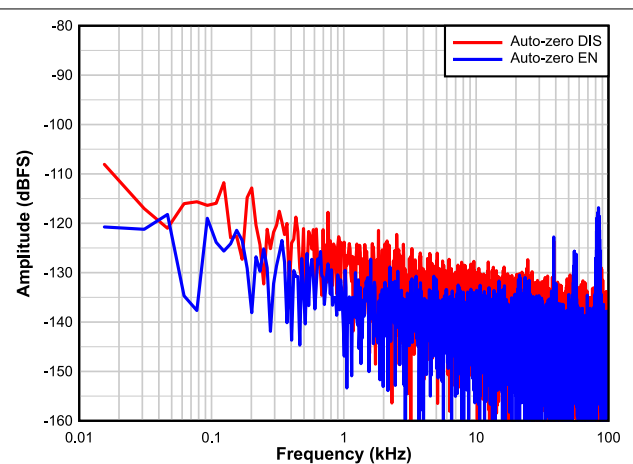
**Figure 7-10.  $F_S = 25\text{MSPS}$ ,  $F_{IN} = 1.1\text{MHz}$**



**Figure 7-11.  $F_S = 25\text{MSPS}$ ,  $F_{IN} = 1.1\text{MHz}$**



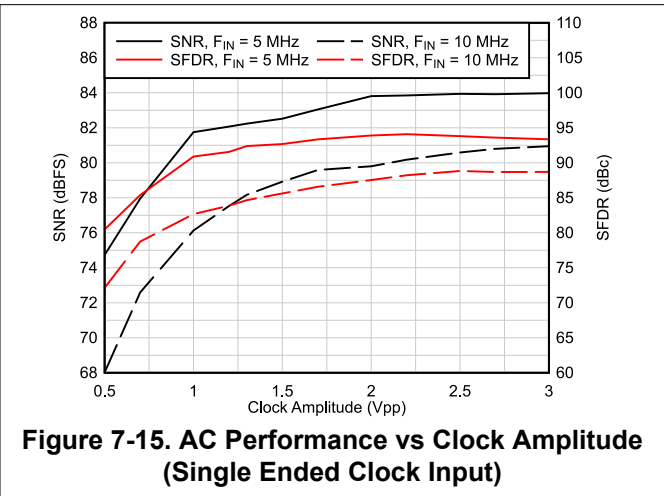
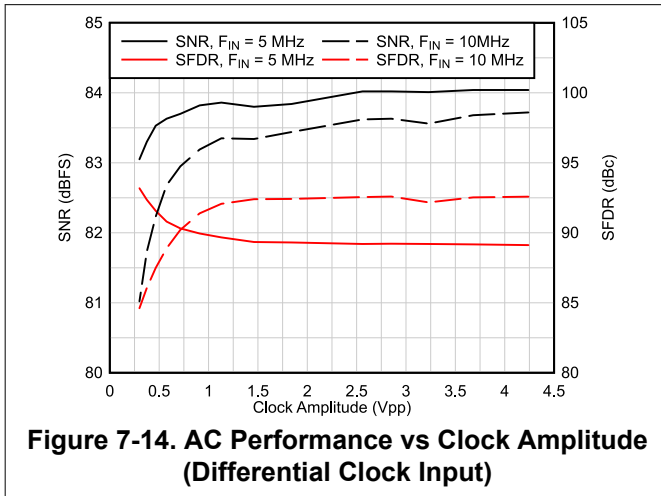
**Figure 7-12.  $F_S = 65\text{MSPS}$ ,  $F_{IN} = 5\text{MHz}$**



**Figure 7-13.  $F_S = 65\text{MSPS}$ ,  $F_{IN} = 5\text{MHz}$**

### 7.3.2 Clock Input

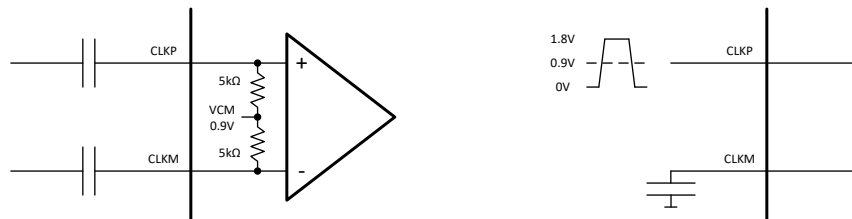
To maximize the ADC SNR performance, the external sampling clock should be low jitter and differential signaling with a high slew rate. This is especially important in IF sampling applications (Figure 7-14 and Figure 7-15). For less jitter sensitive applications, the device provides the option to operate with single ended signaling which saves additional power consumption.



#### 7.3.2.1 Single Ended vs Differential Clock Input

The ADC3683-xEP is operated using a differential or a single ended clock input where the single ended clock consumes less power consumption. However, clock amplitude impacts the ADC aperture jitter and consequently the SNR. For maximum SNR performance, a large clock signal with fast slew rates needs to be provided.

- Differential Clock Input: The clock input is AC coupled externally. The device provides internal bias.
- Single Ended Clock Input: This mode needs to be configured using SPI register (0x0E, D2 and D0) or with the REFBUF/CTRL pin. In this mode, there is no internal clock biasing and thus the clock input needs to be DC coupled around a 0.9V center. The unused input needs to be AC coupled to ground.



**Figure 7-16. External and internal connection using differential (left) and single ended (right) clock input**

### 7.3.2.2 Signal Acquisition Time Adjust

The ADC3683-xEP includes a register (DLL PDN (0x11, D2) which increases the signal acquisition time window for clock rates below 40MSPS from 25% to 50% of the clock period. Increasing the sampling time provides a longer time for the driving amplifier to settle out the signal which can improve the SNR performance of the system. This register is only be used at or below 40MSPS. When powering down the DLL, the acquisition time tracks the clock duty cycle (50% is recommended).

**Table 7-1. Acquisition time vs DLL PDN setting**

SAMPLING CLOCK $F_s$ (MSPS)	DLL PDN (0x11, D2)	ACQUISITION TIME ( $t_{ACQ}$ )
65	0	$T_S / 4$
$\leq 40$	1	$T_S / 2$

### 7.3.3 Voltage Reference

The ADC3683-xEP provides three different options for supplying the voltage reference to the ADC. Connect an external 1.6V reference directly to the VREF input. A voltage 1.2V reference is connected to the REFBUF/CTRL input using the internal gain buffer or the internal 1.2V reference is enabled to generate a 1.6V reference voltage. For best performance, the reference noise should be filtered by connecting a 10 $\mu$ F and a 0.1 $\mu$ F ceramic bypass capacitor to the VREF pin. The internal reference circuitry of the ADC3683-xEP is shown in Figure 7-17.

#### Note

The voltage reference mode is selected using SPI writes or by using the REFBUF/CTRL pin (default) as a control pin (Section 7.5.1). If the REFBUF/CTRL pin is not used for configuration, the pin must be connected to AVDD (even though the REFBUF/CTRL pin has a weak internal pullup to AVDD). The voltage reference option has to be selected using the SPI interface.

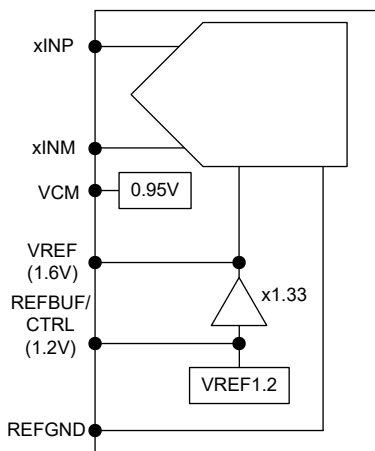


Figure 7-17. Different voltage reference options for ADC3683-xEP

#### 7.3.3.1 Internal voltage reference

Generate the 1.6V reference for the ADC internal using the on-chip 1.2V bandgap reference along with the internal gain buffer. A 10 $\mu$ F and a 0.1 $\mu$ F ceramic bypass capacitor ( $C_{VREF}$ ) is connected between the VREF and REFGND pins as close to the pins as possible.

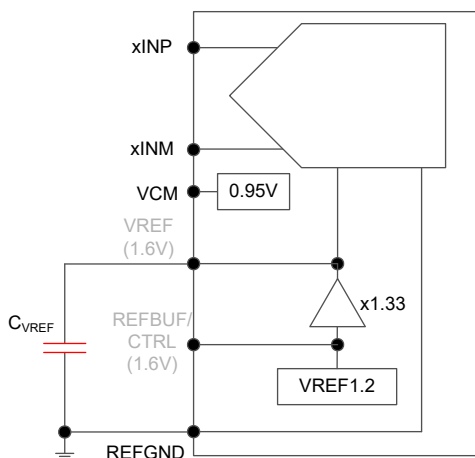


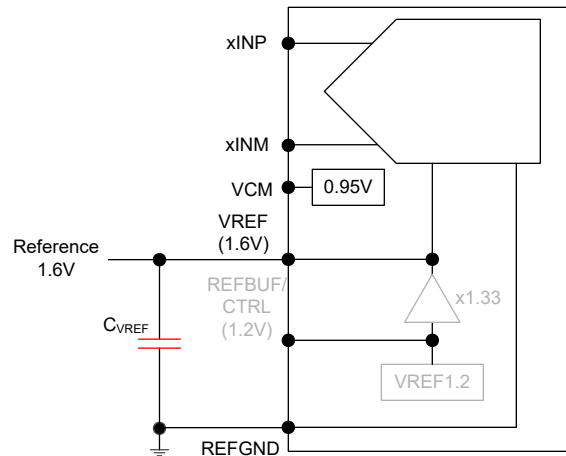
Figure 7-18. Internal reference

### 7.3.3.2 External voltage reference (VREF)

For highest accuracy and lowest temperature drift, the VREF input is connected directly to an external 1.6V reference. A 10 $\mu$ F and a 0.1 $\mu$ F ceramic bypass capacitor ( $C_{VREF}$ ) connected between the VREF and REFGND pins and placed as close to the pins as possible is recommended. The load current from the external reference is about 1mA.

#### Note

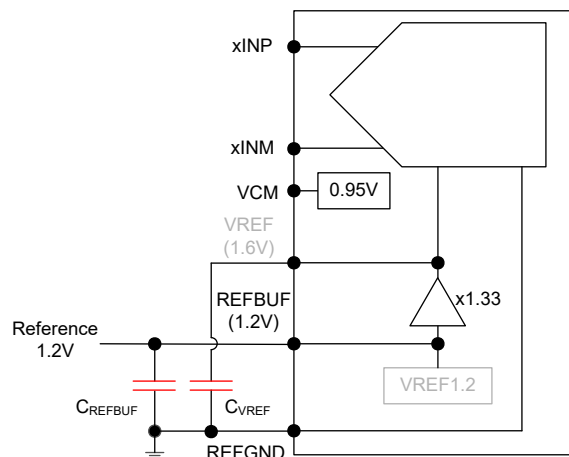
The internal reference is also used for other functions inside the device; therefore, the reference amplifier should only be powered down in power down state but not during normal operation.



**Figure 7-19. External 1.6V reference**

### 7.3.3.3 External voltage reference with internal buffer (REFBUF/CTRL)

The ADC3683-xEP is equipped with an on-chip reference buffer that also includes gain to generate the 1.6V reference voltage from an external 1.2V reference. A 10 $\mu$ F and a 0.1 $\mu$ F ceramic bypass capacitor ( $C_{VREF}$ ) between the VREF and REFGND pins and a 10 $\mu$ F and a 0.1 $\mu$ F ceramic bypass capacitor between the REFBUF/CTRL and REFGND pins are recommended. Both capacitors should be placed as close to the pins as possible. The load current from the external reference is less than 100 $\mu$ A.



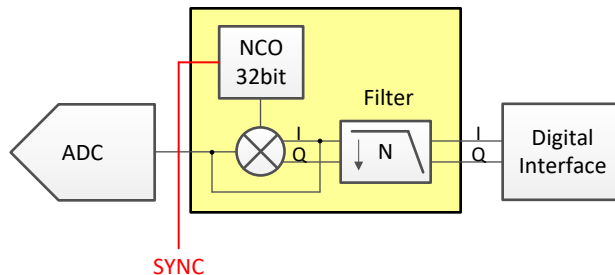
**Figure 7-20. External 1.2V reference using internal reference buffer**

### 7.3.4 Digital Down Converter

The ADC3683-xEP includes an optional on-chip digital down conversion (DDC) decimation filter that is enabled via SPI register settings. Supporting complex decimation by 2, 4, 8, 16 and 32 using a digital mixer and a 32-bit numerically controlled oscillator (NCO) as shown in [Figure 7-21](#).

Supporting a mode with real decimation where the complex mixer is bypassed (NCO should be set to 0 for lowest power consumption) and the digital filter acts as a low pass filter.

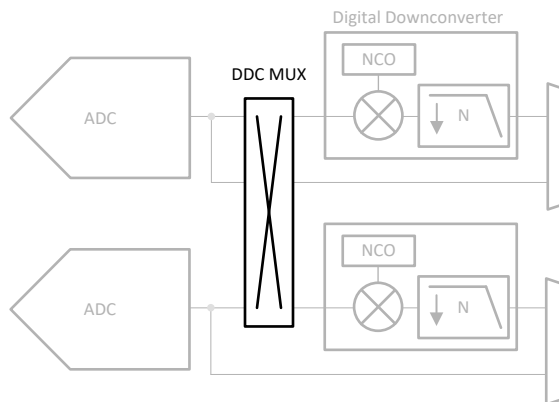
Internally, the decimation filter calculations are performed with a 20-bit resolution to avoid any SNR degradation due to quantization noise limitation. The [Section 7.3.5.1](#) truncates to the selected resolution prior to outputting the data on the digital interface.



**Figure 7-21. Internal digital decimation filter**

#### 7.3.4.1 DDC MUX

The ADC3683-xEP contains a MUX in front of the digital decimation filter which allows ADC ChA to be connected to DDC ChB. This feature is enabled and controlled using the SPI interface. Subsequently the output interface corresponds to the DDC channel A and B.



**Figure 7-22. DDC MUX**

### 7.3.4.2 Digital Filter Operation

The complex decimation operation is illustrated with an example in Figure 7-23. First the input signal (and the negative image) are frequency shifted by the NCO frequency as shown on the left. Next a digital filter is applied (centered around 0 Hz) and the output data rate is decimated by 8 complex. In this example, the output data rate  $F_{S,OUT} = F_S/8$  with a Nyquist zone of  $F_S/16$ . During the complex mixing the spectrum (signal and noise) is split into real and complex parts and thus the amplitude is reduced by 6dB. To compensate this loss, there is a 6dB digital gain option in the decimation filter block that is enabled via SPI write.

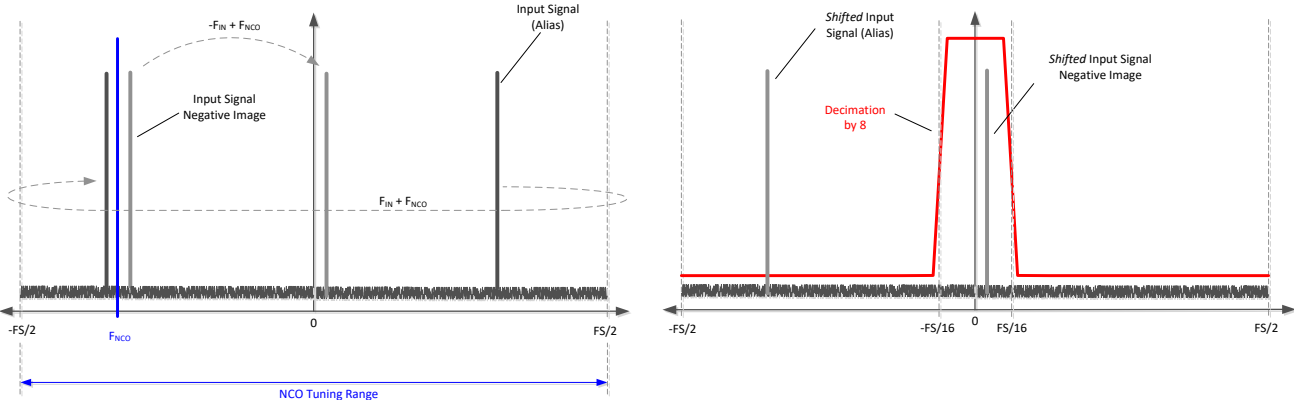


Figure 7-23. Complex decimation illustration

The real decimation operation is illustrated with an example in Figure 7-24. There is no frequency shift happening and only the real portion of the complex digital filter is exercised. The output data rate is decimated - a decimation of 8 results in an output data rate  $F_{S,OUT} = F_S/8$  with a Nyquist zone of  $F_S/16$ .

During the real mixing the spectrum (signal and noise) amplitude is reduced by 3dB. To compensate this loss, there is a 3dB digital gain option in the decimation filter block that is enabled via SPI write.

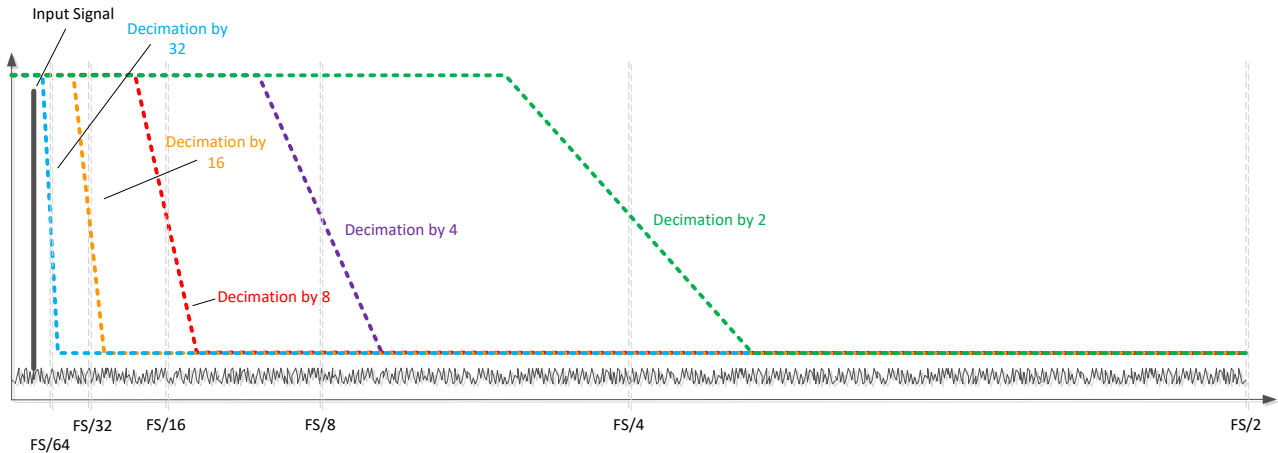


Figure 7-24. Real decimation illustration

### 7.3.4.3 FS/4 Mixing with Real Output

In this mode, the output after complex decimation gets mixed with FS/4 (FS = output data rate in this case). Instead of a complex output with the input signal centered around 0Hz, the output is transmitted as a real output at twice the data rate and the signal is centered around FS/4 (Fout/4) as illustrated in Figure 7-25.

In this example, complex decimation by 8 is used. The output data is transmitted as a real output with an output rate of Fout = FS'/4 (FS' = ADC sampling rate). The input signal is now centered around FS/4 (Fout/4) or FS'/16.

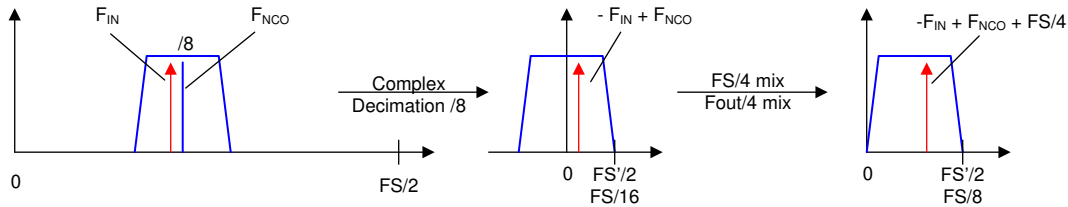


Figure 7-25. FS/4 Mixing with real output

### 7.3.4.4 Numerically Controlled Oscillator (NCO) and Digital Mixer

The decimation block is equipped with a 32-bit NCO and a digital mixer to fine tune the frequency placement prior to the digital filtering. The oscillator generates a complex exponential sequence of:

$$e^{j\omega n} \text{ (default) or } e^{-j\omega n} \quad (1)$$

where: frequency ( $\omega$ ) is specified as a signed number by the 32-bit register setting

The complex exponential sequence is multiplied with the real input from the ADC to mix the desired carrier to a frequency equal to  $f_{IN} + f_{NCO}$ . The NCO frequency is tuned from  $-F_S/2$  to  $+F_S/2$  and is processed as a signed, 2s complement number. After programming a new NCO frequency, the MIXER RESTART register bit or SYNC pin has to be toggled for the new frequency to get active. Additionally, the ADC3683-xEP provides the option via SPI to invert the mixer phase.

The NCO frequency setting is set by the 32-bit register value given and calculated as:

$$\text{NCO frequency} = 0 \text{ to } +F_S/2: \text{NCO} = f_{NCO} \times 2^{32} / F_S \quad (2)$$

$$\text{NCO frequency} = -F_S/2 \text{ to } 0: \text{NCO} = (f_{NCO} + F_S) \times 2^{32} / F_S \quad (3)$$

where:

- NCO = NCO register setting (decimal value)
- $f_{NCO}$  = Desired NCO frequency (MHz)
- $F_S$  = ADC sampling rate (MSPS)

The NCO programming is further illustrated with this example:

- ADC sampling rate  $F_S = 65\text{MSPS}$
- Input signal  $f_{IN} = 10\text{MHz}$
- Desired output frequency  $f_{OUT} = 0\text{MHz}$

For this example, there are actually four ways to program the NCO and achieve the desired output frequency as shown in [Table 7-2](#).

**Table 7-2. NCO value calculations example**

Alias or negative image	$f_{\text{NCO}}$	NCO Value	Mixer Phase	Frequency translation for $f_{\text{OUT}}$
$f_{\text{IN}} = -10\text{MHz}$	$f_{\text{NCO}} = 10\text{MHz}$	660764199	as is	$f_{\text{OUT}} = f_{\text{IN}} + f_{\text{NCO}} = -10\text{MHz} + 10\text{MHz} = 0\text{MHz}$
$f_{\text{IN}} = 10\text{MHz}$	$f_{\text{NCO}} = -10\text{MHz}$	3634203097		$f_{\text{OUT}} = f_{\text{IN}} + f_{\text{NCO}} = 10\text{MHz} + (-10\text{MHz}) = 0\text{MHz}$
$f_{\text{IN}} = 10\text{MHz}$	$f_{\text{NCO}} = 10\text{MHz}$	660764199	inverted	$f_{\text{OUT}} = f_{\text{IN}} - f_{\text{NCO}} = 10\text{MHz} - 10\text{MHz} = 0\text{MHz}$
$f_{\text{IN}} = -10\text{MHz}$	$f_{\text{NCO}} = -10\text{MHz}$	3634203097		$f_{\text{OUT}} = f_{\text{IN}} - f_{\text{NCO}} = -10\text{MHz} - (-10\text{MHz}) = 0\text{MHz}$

### 7.3.4.5 Decimation Filter

The ADC3683-xEP supports complex decimation by 2, 4, 8, 16 and 32 with a stopband rejection of at least 85dB and a pass-band bandwidth of approximately 80%. Table 7-3 gives an overview of the pass-band bandwidth of the different decimation settings with respect to ADC sampling rate  $F_S$ . In real decimation mode, the output bandwidth is half of the complex bandwidth.

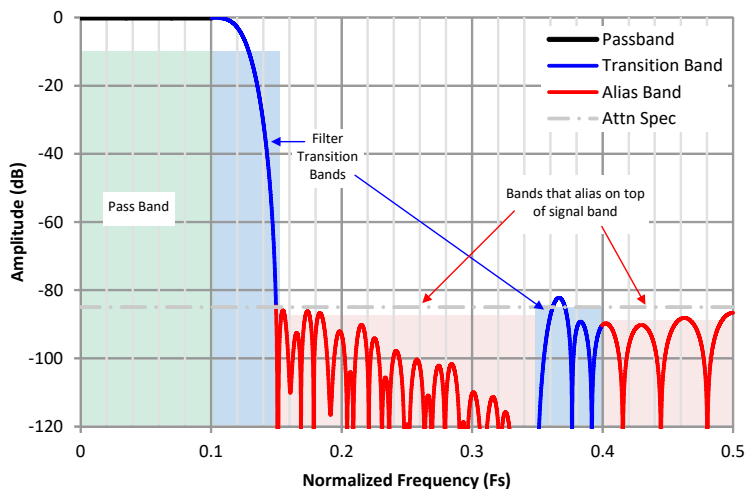
**Table 7-3. Decimation Filter Summary and Maximum Available Output Bandwidth**

REAL/COMPLEX DECIMATION	DECIMATION SETTING N	OUTPUT RATE	OUTPUT BANDWIDTH	OUTPUT RATE ( $F_S = 65$ MSPS)	OUTPUT BANDWIDTH ( $F_S = 65$ MSPS)
Complex	2	$F_S / 2$ complex	$0.8 \times F_S / 2$	32.5MSPS complex	26MHz
	4	$F_S / 4$ complex	$0.8 \times F_S / 4$	16.25MSPS complex	13MHz
	8	$F_S / 8$ complex	$0.8 \times F_S / 8$	8.125MSPS complex	6.5MHz
	16	$F_S / 16$ complex	$0.8 \times F_S / 16$	4.0625MSPS complex	3.25MHz
	32	$F_S / 32$ complex	$0.8 \times F_S / 32$	2.03125MSPS complex	1.625MHz
Real	2	$F_S / 2$ real	$0.4 \times F_S / 2$	32.5MSPS	13MHz
	4	$F_S / 4$ real	$0.4 \times F_S / 4$	16.25MSPS	6.5MHz
	8	$F_S / 8$ real	$0.4 \times F_S / 8$	8.125MSPS	3.25MHz
	16	$F_S / 16$ real	$0.4 \times F_S / 16$	4.0625MSPS	1.625MHz
	32	$F_S / 32$ real	$0.4 \times F_S / 32$	2.03125MSPS	0.8125MHz

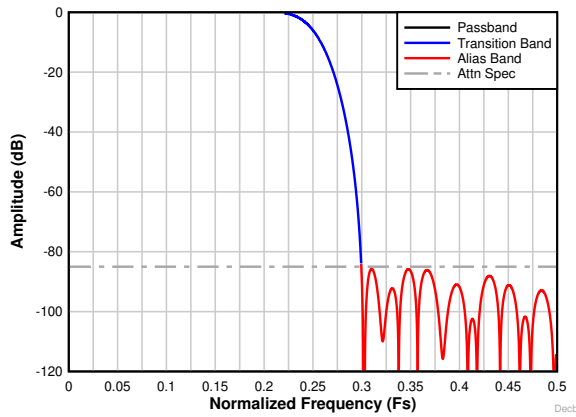
The decimation filter responses are normalized to the ADC sampling clock frequency  $F_S$  and illustrated in Figure 7-27 to Figure 7-36. They are interpreted as follows:

Each figure contains the filter pass-band, transition band(s) and alias or stop-band(s) as shown in Figure 7-26. The x-axis shows the offset frequency (after the NCO frequency shift) normalized to the ADC sampling rate  $F_S$ .

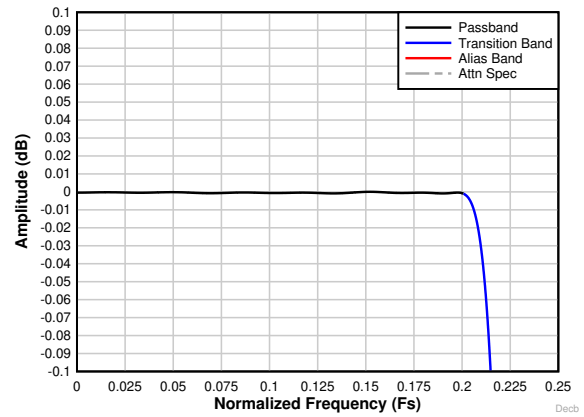
For example, in the divide-by-4 complex setup, the output data rate is  $F_S / 4$  complex with a Nyquist zone of  $F_S / 8$  or  $0.125 \times F_S$ . The transition band (colored in blue) is centered around  $0.125 \times F_S$  and the alias transition band is centered at  $0.375 \times F_S$ . The stop-bands (colored in red), which alias on top of the pass-band, are centered at  $0.25 \times F_S$  and  $0.5 \times F_S$ . The stop-band attenuation is greater than 85dB.



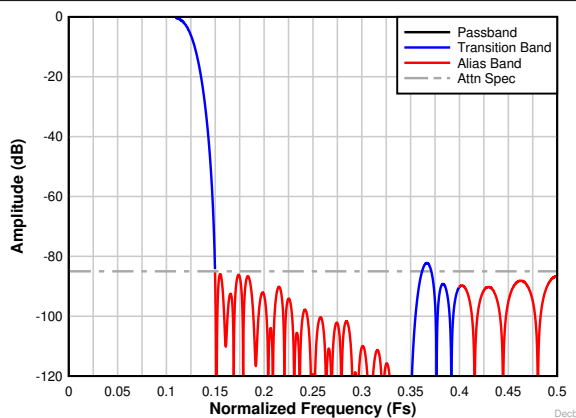
**Figure 7-26. Interpretation of the Decimation Filter Plots**



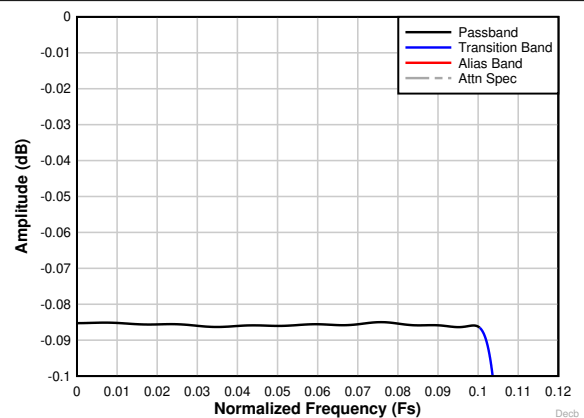
**Figure 7-27. Decimation by 2 complex frequency response**



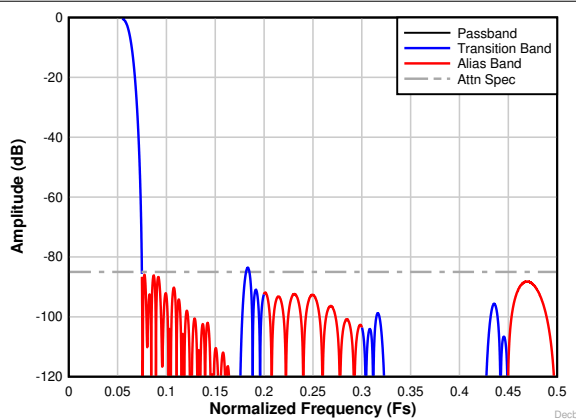
**Figure 7-28. Decimation by 2 complex passband ripple response**



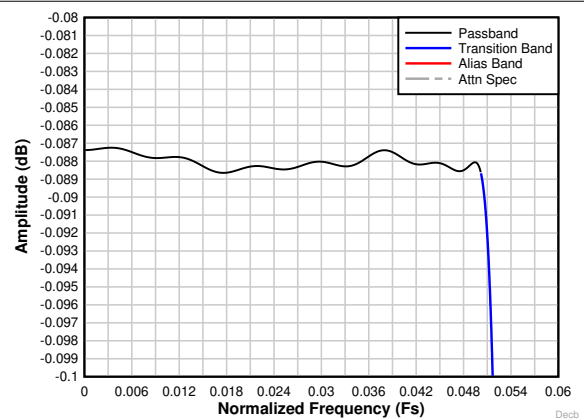
**Figure 7-29. Decimation by 4 complex frequency response**



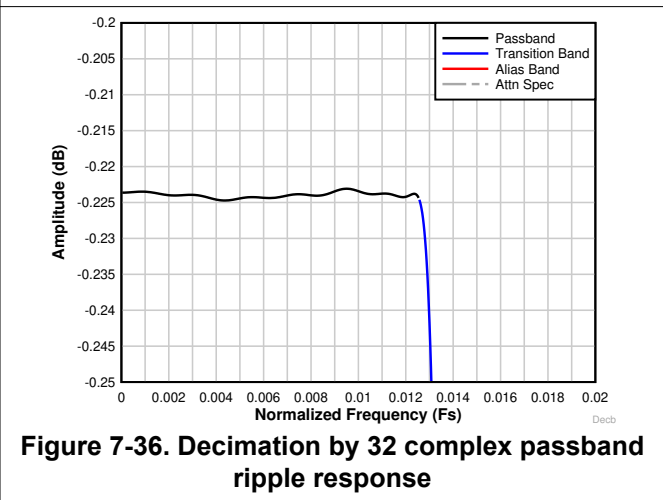
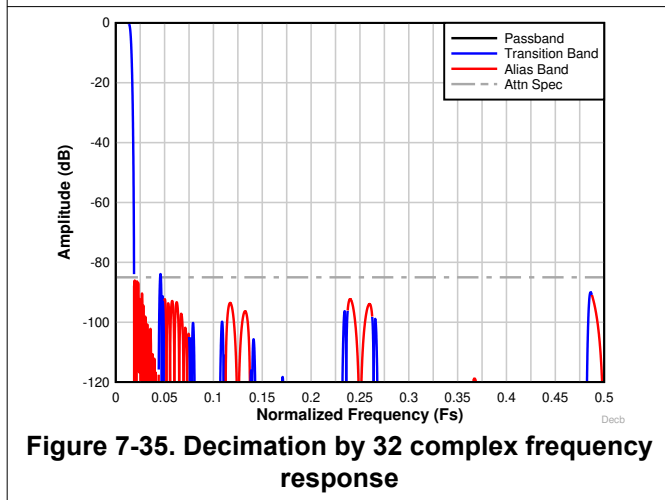
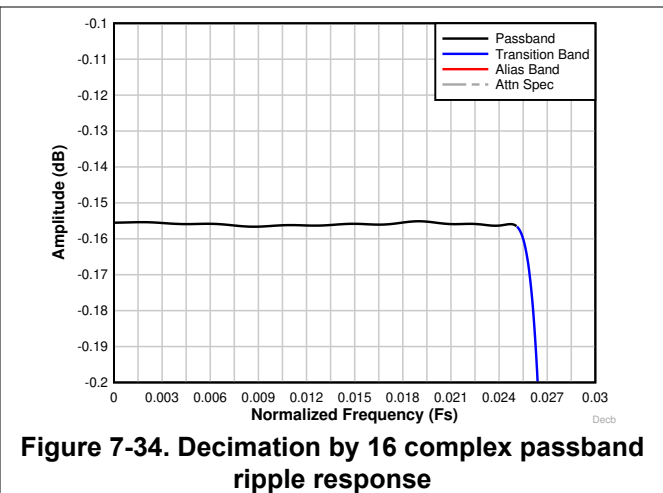
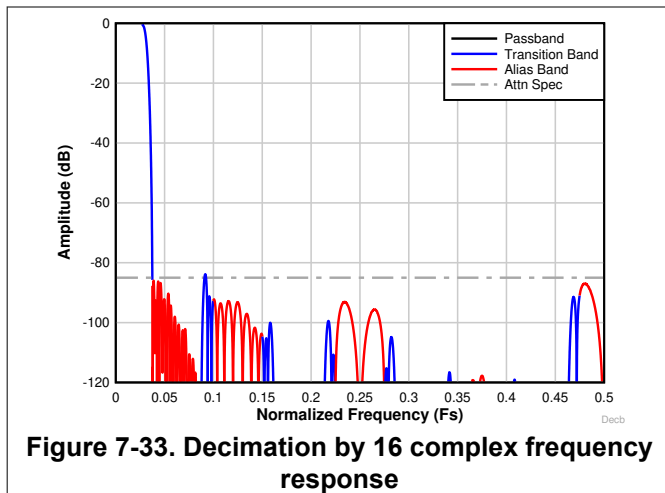
**Figure 7-30. Decimation by 4 complex passband ripple response**



**Figure 7-31. Decimation by 8 complex frequency response**

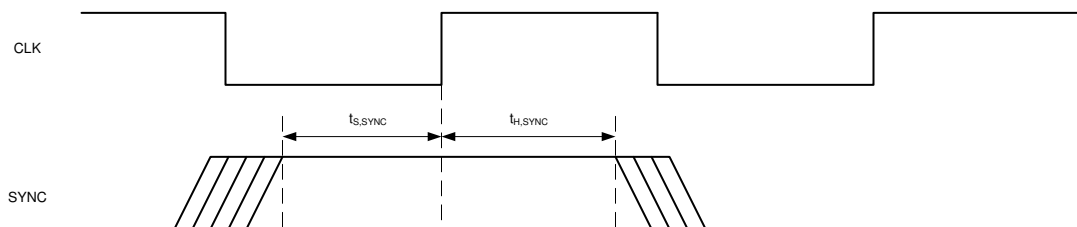


**Figure 7-32. Decimation by 8 complex passband ripple response**



### 7.3.4.6 SYNC

The PDN/SYNC pin is used to synchronize multiple devices using an external SYNC signal. The PDN/SYNC pin is configured through SPI (SYNC EN bit) from power down to synchronization functionality, and is latched in by the rising edge of the sampling clock as shown in [Figure 7-37](#).



**Figure 7-37. External SYNC timing diagram**

The synchronization signal is only required when using the decimation filter - either using the SPI SYNC register or the PDN/SYNC pin. Resetting the internal clock dividers used in the decimation filter, and aligning the internal clocks as well as I and Q data within the same sample. If no SYNC signal is given, the internal clock dividers is not be synchronized, which can lead to a fractional delay across different devices. The SYNC signal also resets the NCO phase and loads the new NCO frequency (same as the MIXER RESTART bit).

When trying to resynchronize during operation, the SYNC toggle occurs at  $64 \cdot K$  clock cycles, where K is an integer. This provides the phase continuity of the clock divider.

### 7.3.4.7 Output Formatting with Decimation

When using decimation, the digital output data is formatted as shown in Figure 7-38 (complex decimation) and Figure 7-39 (real decimation). The output format is illustrated for 18-bit output resolution.

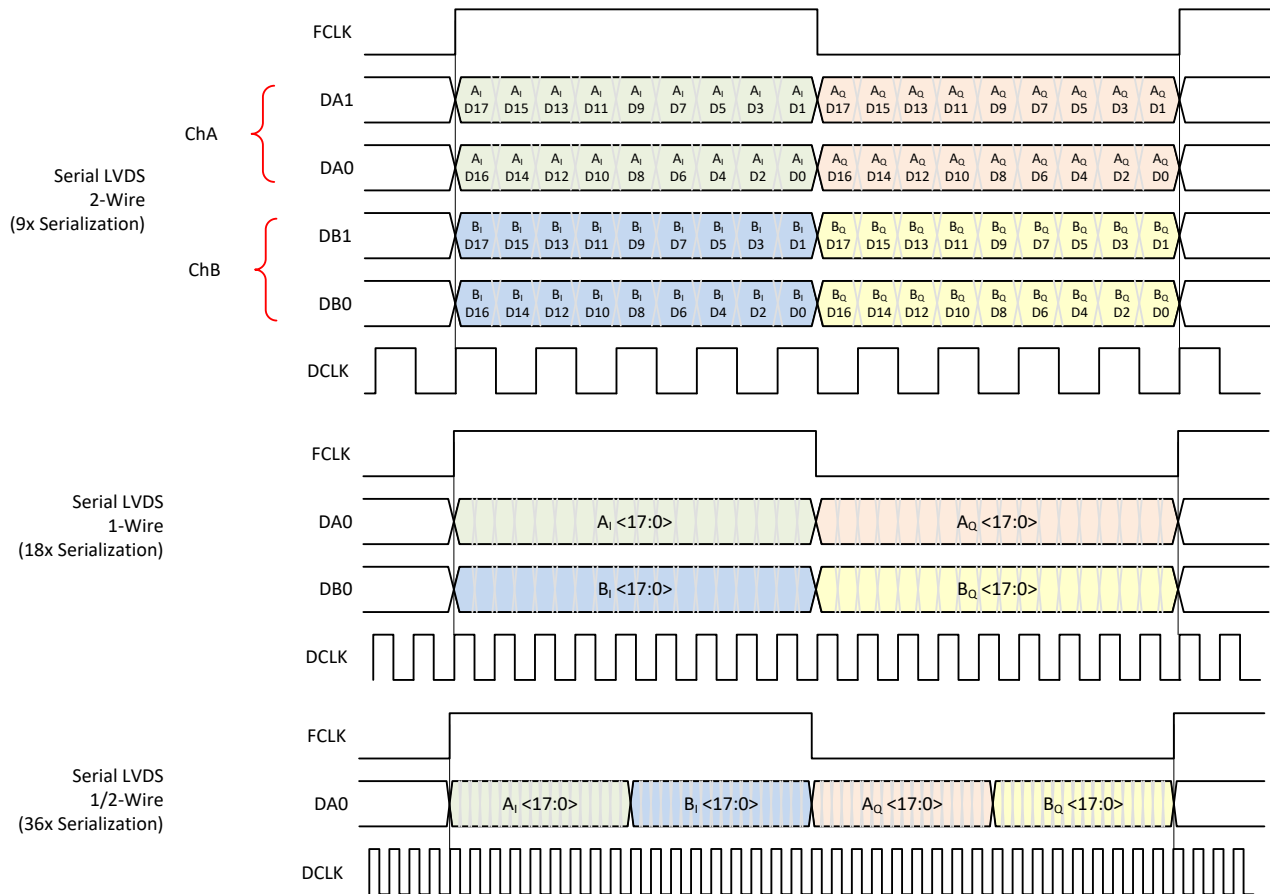


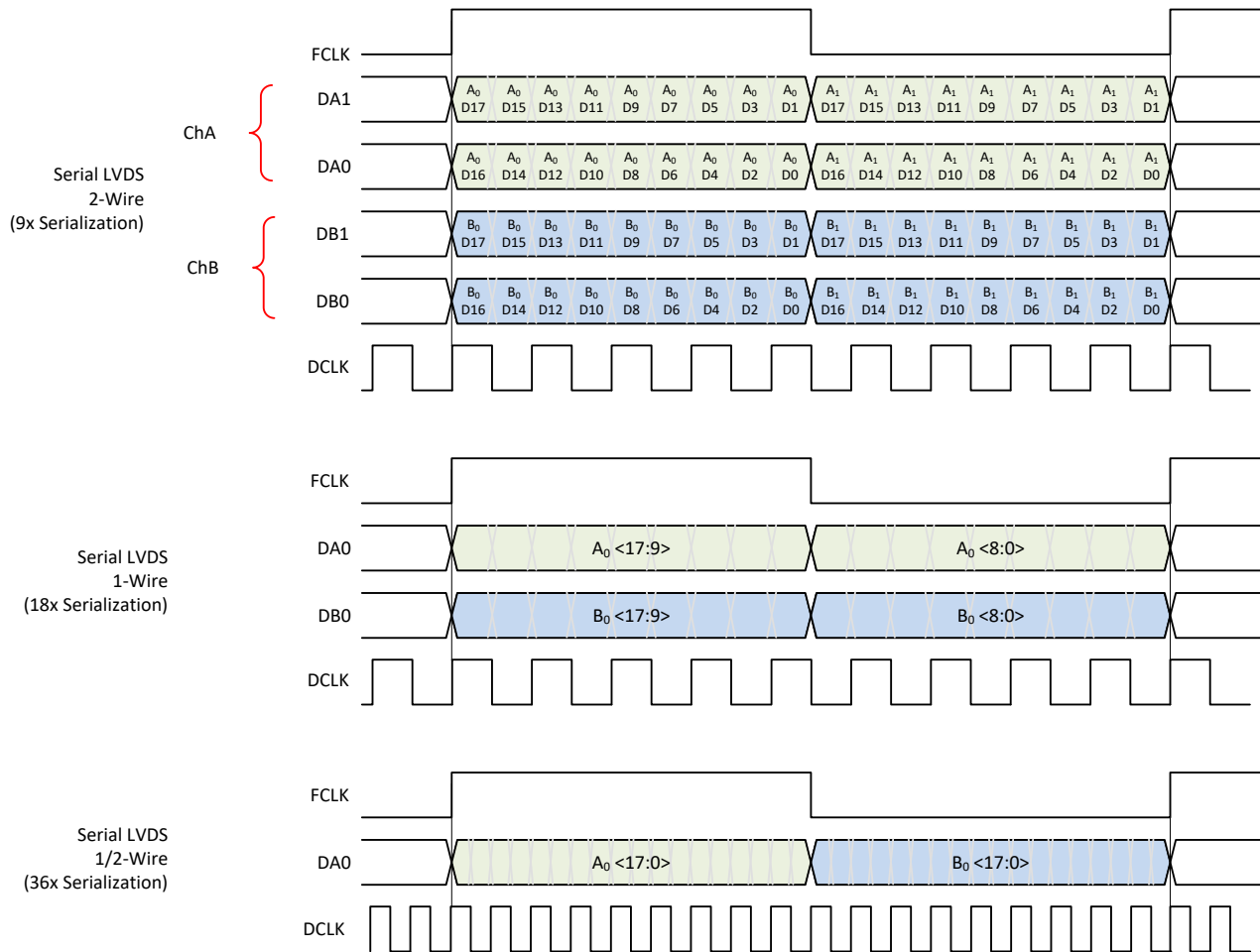
Figure 7-38. Output Data Format in Complex Decimation (18-bit Output Resolution)

Table 7-4 illustrates the output interface data rate along with the corresponding DCLK/DCLKIN and FCLK frequencies based on output resolution (R), number of SLVDS lanes (L) and complex decimation setting (N).

The table shows an actual lane rate example for the 2-, 1- and 1/2-wire interface, 18-bit output resolution and complex decimation by 4.

Table 7-4. Serial LVDS Lane Rate Examples with Complex Decimation and 18-bit Output Resolution

DECIMATION SETTING	ADC SAMPLING RATE	OUTPUT RESOLUTION	# of WIRES	FCLK	DCLKIN, DCLK	DA/B0,1
N	$F_S$	R	L	$F_S / N$	$[DA/B0,1] / 2$	$F_S \times 2 \times R / L / N$
4	65MSPS	18	2	16.25MHz	146.25 MHz	292.5 MHz
			1		292.5 MHz	585 MHz
	55MSPS		1/2	13.75MHz	495 MHz	990 MHz



**Figure 7-39. Output Data Format in Real Decimation (18-bit Output Resolution)**

Table 7-5 illustrates the output interface data rate along with the corresponding DCLK/DCLKIN and FCLK frequencies based on output resolution (R), number of SLVDS lanes (L) and real decimation setting (M).

The table shows an actual lane rate example for the 2-, 1- and 1/2-wire interface, 18-bit output resolution and real decimation by 4.

**Table 7-5. Serial LVDS Lane Rate Examples with Real Decimation and 18-bit Output Resolution**

DECIMATION SETTING	ADC SAMPLING RATE	OUTPUT RESOLUTION	# of WIRES	FCLK	DCLKIN, DCLK	DA/B0,1
M	$F_S$	R	L	$F_S / M / 2$ (L = 2) $F_S / M$ (L = 1, 1/2)	$[DA/B0,1] / 2$	$F_S \times R / L / M$
4	65MSPS	18	2	8.125MHz	73.125 MHz	146.25 MHz
			1	16.25MHz	146.25 MHz	292.5 MHz
			1/2		292.5 MHz	585 MHz

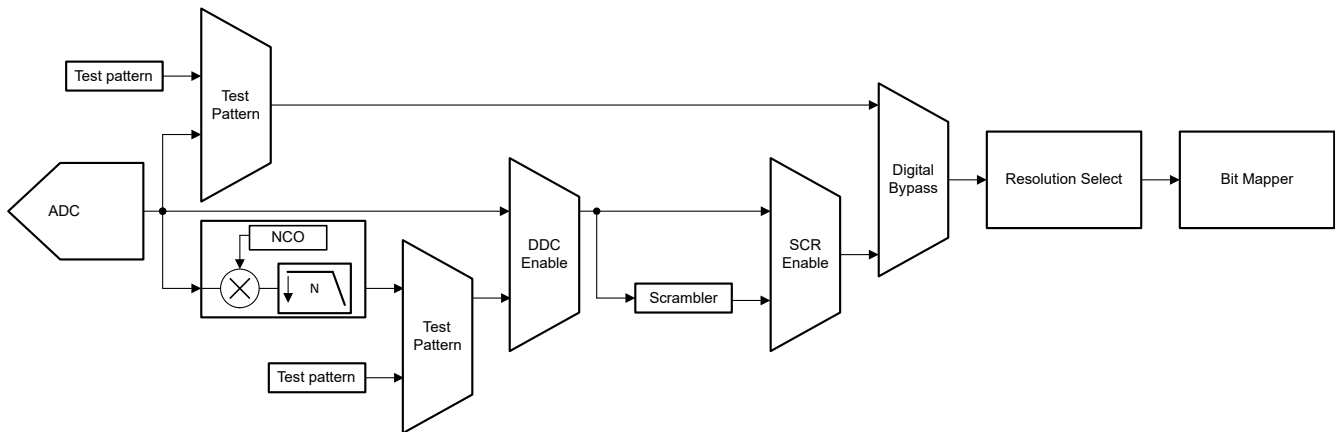
### 7.3.5 Digital Data Path and Interface

The ADC3683-xEP uses a serial LVDS (SLVDS) interface to output the ADC data which minimizes the number of digital interconnects. The SLVDS interface is configured to one of the following modes: two LVDS lanes per channel (2-wire), one LVDS lane per channel (1-wire), or a half-lane mode (1/2-wire) option where both channels are multiplexed on a single LVDS lane. The device supports configurable output resolutions from 14-bit to 20-bit.

The ADC3683-xEP requires an external interface clock (DCLKIN). A delayed version of DCLKIN is used as the interface output clock (DCLK).

#### 7.3.5.1 Data Path Overview

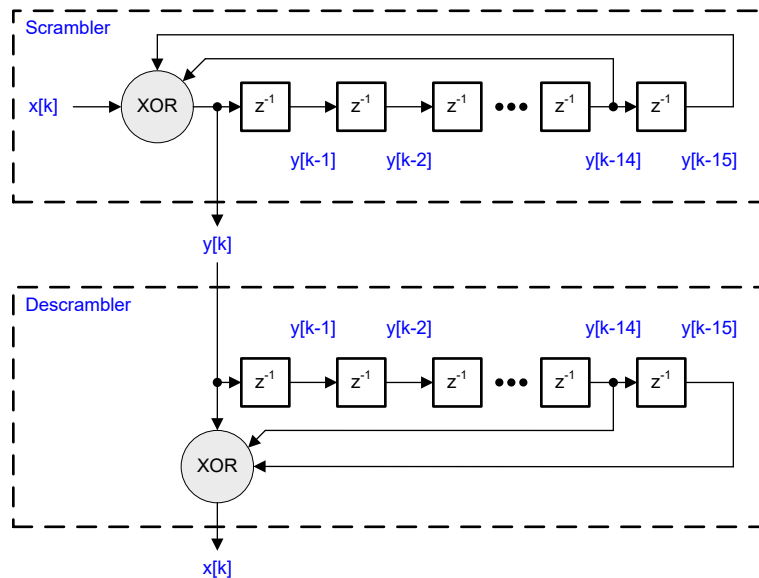
The ADC3683-xEP offers a flexible set of digital features (Figure 7-40) where all, or a subset of the features are used. The core ADC provides an 18-bit output which is passed to the digital down converter (DDC), or directly provided to the digital interface through the resolution selector and bit mapper. Since the ADC core offers low latency, the digital blocks must be bypassed (D2 of 0x24) for the lowest latency. The final data path goes through a resolution selection block and an output bit mapper. The resolution selector offers selection of a 14-bit, 16-bit, 18-bit, or 20-bit output. For 14-bit and 16-bit output resolutions, the LSBs are truncated during the reformatting. With 20-bit output, in bypass mode, two 0s are added. Two LSBs are added for 20-bit mode in decimation modes. Lastly, the output bit mapper maps the bit transmit order on the active lanes. The output serialization factor is internally adjusted based the 2-, 1-, and 1/2-wire interface modes and resolution; however, the maximum SLVDS interface output data rate of 1Gbps can not be exceeded regardless of the interface settings.



**Figure 7-40. Digital Data Path Overview**

### 7.3.5.2 Output Scrambler

The ADC3683-xEP includes an optional output scrambler feature in 2-wire mode only. The scrambler can be enabled by enabling the DSP features (D2 of 0x24) and enabling scrambling (D6 of 0x22). When enabled, each sample is split into two halves. Each half of the samples stream is scrambled independently. For example, if the samples stream is at an 18-bit resolution, the stream is divided into two halves consisting of bits D17-D9 & D8-D0. The two halves are fed into independent scrambling blocks where each input bit ( $x[k]$ ) of each scrambler is XOR-ed with 2 previous bits ( $y[k-14]$  and  $y[k-15]$ ) as shown in Figure 7-41. Since this is a self-synchronizing scrambler, the start up state of the scrambler is ignored.



**Figure 7-41. Scrambler and Descrambler Operation**

#### Note

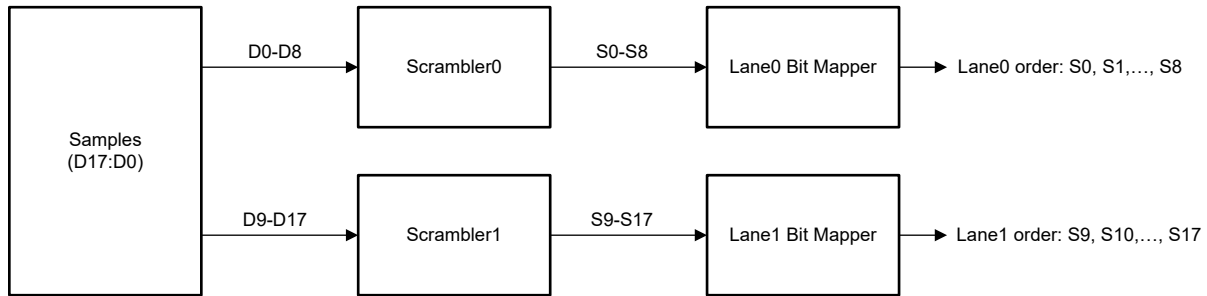
The sample streams fed into each scrambler are fed to the scrambler LSB first. Therefore, in the previous example, the sample stream half consisting of D8-D0 is provided to the scrambler with D0 first as  $x[k]$  followed by D1 as  $x[k+1]$  and so on.

For proper descrambling, the sample stream halves are descrambled independently, then the descrambled data is used to reconstruct the samples. On the receiver side, the incoming serial data stream is descrambled by XOR-ing each incoming bit ( $y[k]$ ) with 2 previous bits ( $y[k-14]$  and  $y[k-15]$ ).

**Note**

Since the scramblers are looking at the two halves of the sample stream, the output bit mapper needs to be configured such that each lane contains only one of the sample halves.

For example, in 2-wire and 18-bit mode, by default (Figure 6-1), one lane carries the odd bits (D17, D15, D13, etc.) and one lane carries the even bits (D16, D14, D12, and so on). When scrambling is enabled, the bit mapper needs to be configured so that one lane carries bits D9-D17 and the other lane carries D0-D8 (LSB first for each lane). An example data flow diagram of scrambling an 18-bit sample stream is shown in Figure 7-42, where D17:D0 is the sample provided by the ADC after the resolution select block, the sample is split into D0-D8 and D9-D17 and fed into each scrambler (LSB first) and S0-S17 are the resultant scrambled bits.



**Figure 7-42. 18-bit Scrambling Example**

### 7.3.5.3 Output Bit Mapper

The output bit mapper sits right before the physical output interface and dictates the transmitted bit order on each active lane. Each sample bit is uniquely identifiable by a value as shown in [Table 7-6](#). Similarly, each bit position in each lane is also uniquely identifiable with each bit position having an independent register address. To map a specific bit to a specific bit position (and a specific lane), the value for the bit from the [Table 7-6](#) needs to be written to the address corresponding to the desired bit position in the desired lane.

The ADC3683-xEP supports a maximum output resolution of 20-bit; therefore, there are 20-bits that are uniquely identifiable per channel. In 2-wire mode, two samples are considered part of the same frame; therefore, there are two sets of 20-bits each, one for the previous sample and another for the current sample. [Section 7.3.5.3.1](#), [Section 7.3.5.3.2](#), and [Section 7.3.5.3.3](#) provide the register addresses that correspond to each bit position in each lane for 2-wire, 1-wire, and 1/2-wire, respectively.

**Table 7-6. Unique Bit Identifiers**

BIT_ID	Channel A		Channel B	
	Previous sample (2w only)	Current sample	Previous sample (2w only)	Current sample
D19 (MSB)	0x2D	0x6D	0x29	0x69
D18	0x2C	0x6C	0x28	0x68
D17	0x27	0x67	0x23	0x63
D16	0x26	0x66	0x22	0x62
D15	0x25	0x65	0x21	0x61
D14	0x24	0x64	0x20	0x60
D13	0x1F	0x5F	0x1B	0x5B
D12	0x1E	0x5E	0x1A	0x5A
D11	0x1D	0x5D	0x19	0x59
D10	0x1C	0x5C	0x18	0x58
D9	0x17	0x57	0x13	0x53
D8	0x16	0x56	0x12	0x52
D7	0x15	0x55	0x11	0x51
D6	0x14	0x54	0x10	0x50
D5	0x0F	0x4F	0x0B	0x4B
D4	0x0E	0x4E	0x0A	0x4A
D3	0x0D	0x4D	0x09	0x49
D2	0x0C	0x4C	0x08	0x48
D1	0x07	0x47	0x03	0x43
D0 (LSB)	0x06	0x46	0x02	0x42

### 7.3.5.3.1 2-Wire Mode

In this mode, both the current and the previous sample have to be used in the address space as shown in [Figure 7-43](#). The address order is different for 14/18-bit and 16/20-bit.

#### Note

There are unused addresses between samples for resolution less than 20-bit (gray back ground), which is skipped if not used.

		14-bit								16-bit				18-bit				20-bit				14-bit								16-bit				18-bit				20-bit							
DA1	14/18-bit	0x5F	0x60	0x5D	0x5E	0x5B	0x5C	0x59	0x5A	0x57	0x58	0x55	0x56	0x53	0x54	0x51	0x52	0x51	0x50	0x4F	0x50	0x4D	0x4E	0x60	0x5F	0x5E	0x5D	0x5C	0x5B	0x5A	0x59	0x58	0x57	0x56	0x55	0x54	0x53	0x52	0x51	0x50	0x4F	0x4E	0x4D	0x4E	0x4D
DA0	14/18-bit	0x4B	0x4C	0x49	0x4A	0x47	0x48	0x45	0x46	0x43	0x44	0x41	0x42	0x3F	0x40	0x3D	0x3E	0x3B	0x3C	0x39	0x3A	0x37	0x38	0x4C	0x4B	0x4A	0x49	0x48	0x47	0x46	0x45	0x44	0x43	0x42	0x41	0x40	0x3F	0x3E	0x3D	0x3C	0x3B	0x3A	0x39	0x3A	0x39
DB1	14/18-bit	0x87	0x88	0x85	0x86	0x83	0x84	0x81	0x82	0x7F	0x7E	0x7D	0x7C	0x7B	0x79	0x7A	0x77	0x78	0x75	0x76	0x88	0x87	0x86	0x85	0x84	0x83	0x82	0x81	0x80	0x7F	0x7E	0x7D	0x7C	0x7B	0x7A	0x79	0x78	0x77	0x76	0x75	0x76	0x75			
DB0	14/18-bit	0x73	0x74	0x71	0x72	0x6F	0x70	0x6D	0x6E	0x6B	0x6C	0x69	0x6A	0x67	0x68	0x65	0x66	0x63	0x64	0x61	0x62	0x74	0x73	0x72	0x71	0x70	0x6F	0x6E	0x6D	0x6C	0x6B	0x6A	0x69	0x68	0x67	0x66	0x65	0x64	0x63	0x62	0x61	0x62	0x61		

Figure 7-43. 2-wire output bit mapper

In the following example ([Figure 7-44](#)), the 16-bit 2-wire serial output is reordered to where lane DA1/DB1 carries the 8 MSB and lane DA0/DB0 carries 8 LSBs.

	Previous Sample								Current Sample							
DA1	D19 <sub>A</sub> (0x60 0x2D)	D18 <sub>A</sub> (0x5F 0x2C)	D17 <sub>A</sub> (0x5E 0x27)	D16 <sub>A</sub> (0x5D 0x26)	D15 <sub>A</sub> (0x5C 0x25)	D14 <sub>A</sub> (0x5B 0x24)	D13 <sub>A</sub> (0x5A 0x1F)	D12 <sub>A</sub> (0x59 0x1E)	D19 <sub>A</sub> (0x56 0x6D)	D18 <sub>A</sub> (0x55 0x6C)	D17 <sub>A</sub> (0x54 0x67)	D16 <sub>A</sub> (0x53 0x66)	D15 <sub>A</sub> (0x52 0x65)	D14 <sub>A</sub> (0x51 0x64)	D13 <sub>A</sub> (0x50 0x5F)	D12 <sub>A</sub> (0x4F 0x5E)
DA0	D11 <sub>A</sub> (0x4C 0x1D)	D10 <sub>A</sub> (0x4B 0x1C)	D9 <sub>A</sub> (0x4A 0x17)	D8 <sub>A</sub> (0x49 0x16)	D7 <sub>A</sub> (0x48 0x15)	D6 <sub>A</sub> (0x47 0x14)	D5 <sub>A</sub> (0x46 0x0F)	D4 <sub>A</sub> (0x45 0x0E)	D11 <sub>A</sub> (0x42 0x5D)	D10 <sub>A</sub> (0x41 0x5C)	D9 <sub>A</sub> (0x40 0x57)	D8 <sub>A</sub> (0x39 0x56)	D7 <sub>A</sub> (0x38 0x55)	D6 <sub>A</sub> (0x37 0x54)	D5 <sub>A</sub> (0x36 0x4F)	D4 <sub>A</sub> (0x35 0x4E)
DB1	D19 <sub>B</sub> (0x88 0x29)	D18 <sub>B</sub> (0x87 0x28)	D17 <sub>B</sub> (0x86 0x23)	D16 <sub>B</sub> (0x85 0x22)	D15 <sub>B</sub> (0x84 0x21)	D14 <sub>B</sub> (0x83 0x20)	D13 <sub>B</sub> (0x82 0x1B)	D12 <sub>B</sub> (0x81 0x1A)	D19 <sub>B</sub> (0x7E 0x69)	D18 <sub>B</sub> (0x7D 0x68)	D17 <sub>B</sub> (0x7C 0x63)	D16 <sub>B</sub> (0x7B 0x62)	D15 <sub>B</sub> (0x7A 0x61)	D14 <sub>B</sub> (0x79 0x54)	D13 <sub>B</sub> (0x78 0x53)	D12 <sub>B</sub> (0x77 0x4E)
DB0	D11 <sub>B</sub> (0x74 0x19)	D10 <sub>B</sub> (0x73 0x18)	D9 <sub>B</sub> (0x72 0x13)	D8 <sub>B</sub> (0x71 0x12)	D7 <sub>B</sub> (0x70 0x11)	D6 <sub>B</sub> (0x6F 0x10)	D5 <sub>B</sub> (0x6E 0x0B)	D4 <sub>B</sub> (0x6D 0x0A)	D11 <sub>B</sub> (0x6A 0x59)	D10 <sub>B</sub> (0x69 0x58)	D9 <sub>B</sub> (0x68 0x53)	D8 <sub>B</sub> (0x67 0x52)	D7 <sub>B</sub> (0x66 0x51)	D6 <sub>B</sub> (0x65 0x50)	D5 <sub>B</sub> (0x64 0x4B)	D4 <sub>B</sub> (0x63 0x4A)

Figure 7-44. Example: 2-wire output bit mapping

### 7.3.5.3.2 1-Wire Mode

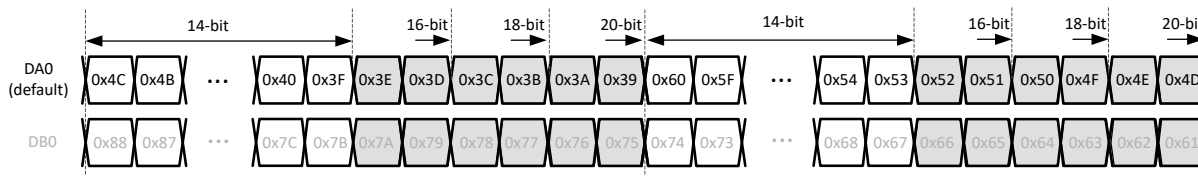
Only the *current sample* needs to be programmed in the address space. If desired, the current sample is duplicated on DA1/DB1 as well (using addresses shown below) to have a redundant output. In this case, lane DA1/DB1 needs to be powered up.

	14-bit								16-bit				18-bit				20-bit			
DA0 (default)	0x4C	0x4B	0x4A	0x49	0x48	0x47	0x46	0x45	0x44	0x43	0x42	0x41	0x40	0x3F	0x3E	0x3D	0x3C	0x3B	0x3A	0x39
DA1	0x60	0x5F	0x5E	0x5D	0x5C	0x5B	0x5A	0x59	0x58	0x57	0x56	0x55	0x54	0x53	0x52	0x51	0x50	0x4F	0x4E	0x4D
DB0 (default)	0x74	0x73	0x72	0x71	0x70	0x6F	0x6E	0x6D	0x6C	0x6B	0x6A	0x69	0x68	0x67	0x66	0x65	0x64	0x63	0x62	0x61
DB1	0x88	0x87	0x86	0x85	0x84	0x83	0x82	0x81	0x80	0x7F	0x7E	0x7D	0x7C	0x7B	0x7A	0x79	0x78	0x77	0x76	0x75

Figure 7-45. 1-wire output bit mapping

### 7.3.5.3.3 1/2-Wire Mode

The output is only lane DA0 and the sample order is programmed into the 40 addresses of chA (from 0x39 to 0x60). Covering 2 samples (one for chA, one for chB) as shown below. To have a redundant output, duplicate on DB0 (using addresses shown in Figure 7-46). In that case, Lane DB0 needs to be powered up.



**Figure 7-46. 1/2-wire output bit mapping**

### 7.3.5.4 Device Configuration Steps

The following sequence summarizes all the relevant registers for changing the ADC3683-xEP modes including DDC and output interface. Steps 1 and 2 must come first since the E-Fuse loader resets some of the device registers, the remaining steps can come in any order.

**Table 7-7. Configuration steps for changing interface or decimation**

STEP	FEATURE	ADDRESS	DESCRIPTION				
1	Output Interface	0x07	Select the output interface bit mapping depending on resolution and output interface.				
			Output Resolution	2-wire	1-wire	1/2-wire	
			14-bit	0x2B	0x6C	0x8D	
			16-bit	0x4B			
			18-bit	0x2B			
20-bit	0x4B						
2		0x13	Load the output interface bit mapping using the E-fuse loader (0x13, D0). Program register 0x13 to 0x01, wait ~ 1ms so that bit mapping is loaded properly followed by 0x13 0x00.				
3	Output Interface	0x19	Configure the FCLK frequency based on bypass/decimation and number of lanes used.				
			Bypass/Dec	SLVDS	FCLK SRC (D7)	FCLK DIV (D4)	TOG FCLK (D0)
			Bypass/ Real Decimation	2-wire	0	1	0
				1-wire	0	0	0
				1/2-wire	0	0	0
			Complex Decimation	2-wire	1	0	0
				1-wire	1	0	0
1/2-wire	0	0		1			
4		0x1B	Select the output interface resolution using the bit mapper (D5-D3).				
5	Output Interface	0x20 0x21 0x22	Select the FCLK pattern based on decimation mode for the proper duty cycle output of the frame clock.				
				Output Resolution	2-wire	1-wire	1/2-wire
			Real Decimation	14-bit	use default	0xFE00	use default
				16-bit		0xFF00	
				18-bit		0xFF80	
				20-bit		0xFFC0	
			Complex Decimation	14-bit	use default	0xFFFF	0xFFFF
				16-bit			
				18-bit			
				20-bit			
6		0x39..0x60 0x61..0x88	Change output bit mapping from the default as needed (e.g., if enabling the scrambler).				
7		0x24 0x22	Optionally, enable scrambling.				

**Table 7-7. Configuration steps for changing interface or decimation (continued)**

STEP	FEATURE	ADDRESS	DESCRIPTION		
8	Decimation Filter	0x24	Enable the decimation filter		
9		0x25	Configure the decimation filter		
10		0x2A/B/C/D 0x31/2/3/4	Program the NCO frequency for complex decimation (skipped for real decimation)		
11		0x27 0x2E	Configure the complex output data stream (set both bits to 0 for real decimation)		
			SLVDS	OP-Order (D4)	Q-Delay (D3)
			2-wire	1	0
	1-wire		0	1	
		1/2-wire	1	1	
12		0x26	Set the mixer gain and toggle the mixer reset bit to update the NCO frequency.		

### 7.3.5.4.1 Configuration Example

The following is a step by step programming example to configure the ADC3683-xEP to complex decimation by 8 with 1-wire SLVDS and 16-bit output.

1. 0x07 (address) 0x6C (load bit mapper configuration for 16-bit output with 1-wire SLVDS)
2. 0x13 0x01, wait 1 ms, 0x13 0x00 (load e-fuse)
3. 0x19 0x80 (configure FCLK)
4. 0x1B 0x88 (select 16-bit output resolution)
5. 0x20 0xFF, 0x21 0xFF, 0x22 0x0F (configure FCLK pattern)
6. 0x24 0x06 (enable decimation filter)
7. 0x25 0x30 (configure complex decimation by 8)
8. 0x2A/B/C/D and 0x31/32/33/34 (program NCO frequency)
9. 0x27/0x2E 0x08 (configure Q-delay register bit)
10. 0x26 0xAA, 0x26 0x88 (set digital mixer gain to 6dB and toggle the mixer update)

### 7.3.5.5 Output Data Format

The ADC3683-xEP samples are configured for either two's complement format (default) or offset binary via SPI (D2 of 0x8F and 0x92). [Table 7-8](#) provides an overview for minimum and maximum output codes for the two formatting options based on resolution.

**Table 7-8. Minimum and Maximum ADC Codes**

RESOLUTION (BIT)	Two's Complement (default)				Offset Binary			
	14	16	18	20	14	16	18	20
$V_{IN,MAX}$	0x1FFF	0x7FFF	0x1FFFF	0x7FFFF	0x3FFF	0xFFFF	0x3FFFF	0xFFFFF
0	0x0000		0x00000		0x2000	0x8000	0x20000	0x80000
$V_{IN,MIN}$	0x2000	0x8000	0x20000	0x80000	0x0000		0x00000	

### 7.3.6 Test Pattern

[Figure 7-40](#) shows the location of the test pattern blocks within the device. When the digital signal processing (DSP) features are disabled (D2 of 0x24), a test pattern block is enabled to replace the ADC data. Similarly, when using the DDC, a test pattern is available to replace the DDC data.

#### Note

No test pattern block is available when the DSP features are enabled and the DDC is not used.

Each test pattern block has the capability to generate one of the following outputs:

- Ramp pattern with programmable step size set by PAT\_DATA.
- Constant pattern with a programmable custom pattern set by PAT\_DATA.

[Figure 7-40](#) shows there are two test pattern blocks, test pattern 0 and test pattern 1. There are two test pattern blocks, test pattern 0 and test pattern 1. The test pattern mode for each block is configured via D7:D5 and D4:D2 of 0x16. A shared set of data bits (PAT\_DATA) is given to the test pattern blocks and this data is used as ramp pattern step size and/or the constant pattern. The PAT\_DATA is an 18-bit value located across three different registers: D17:D16 in 0x16, D15:D8 in 0x15, and D7:D0 in 0x14. The PAT\_DATA is MSB aligned. For example, if the device is configured for 14-bit resolution and constant pattern, only the top 14-bits of the PAT\_DATA are used for the constant pattern. Additionally, in ramp mode, the test pattern counter operates at a 18-bit resolution; therefore, the ramp pattern step size must be configured based on the desired resolution and the step size at that resolution.

- The test pattern data must be configured to the following for a step size of one at each resolution:
  - 0x00001: 18-bit output resolution
  - 0x00004: 16-bit output resolution
  - 0x00010: 14-bit output resolution

## 7.4 Device Functional Modes

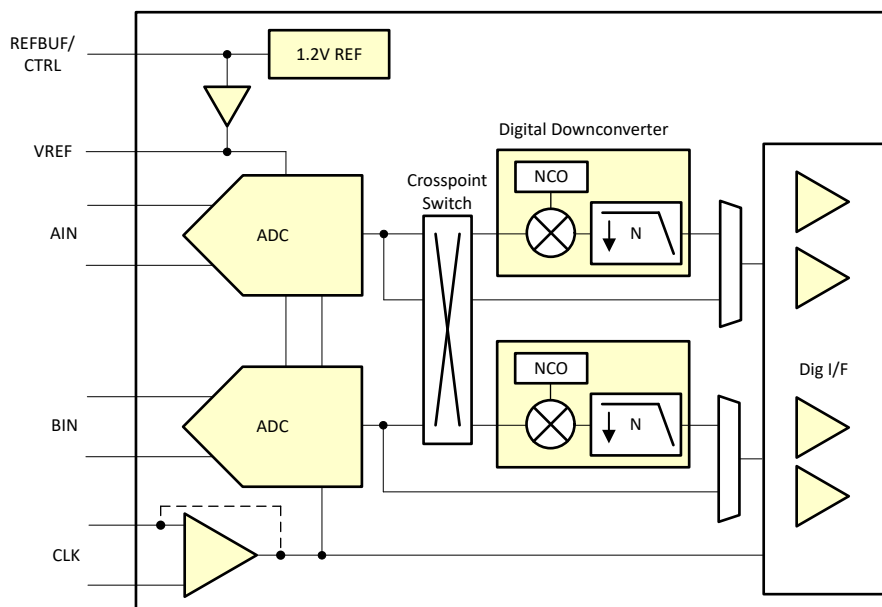
### 7.4.1 Normal Operation

In normal operating mode, the entire ADC full-scale range gets converted to a digital output with 18-bit resolution.

### 7.4.2 Power Down Options

A global power down mode is enabled via SPI as well as using the power down pin (PDN/SYNC). There is an internal pull-down 21kΩ resistor on the PDN/SYNC input pin and the pin is active high, so the pin must be pulled high externally to enter global power down mode.

The SPI register map provides the capability to enable/disable individual blocks directly or via PDN pin mask to trade off power consumption vs wake up time as shown in [Table 7-9](#).



**Figure 7-47. Power Down Configurations**

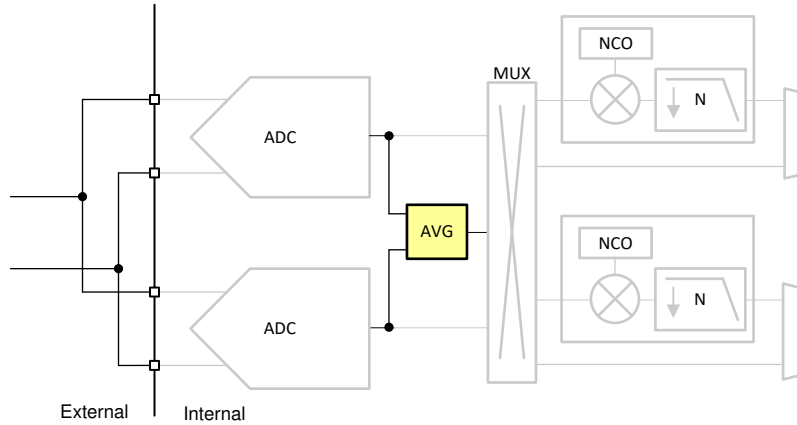
**Table 7-9. Overview of Power Down Options**

Function/ Register	PDN via SPI	Mask for Global PDN	Feature - Default	Power Impact	Wake-up time	Comment
ADC	Yes	-	Enabled			Both ADC channels are included in Global PDN automatically
Reference gain amplifier	Yes	Yes	Enabled	~ 0.4mA	~3us	Should only be powered down in power down state.
Internal 1.2V reference	Yes		External ref	~ 1-3.5mA	~3ms	Internal/external reference selection is available through SPI and REFBUF/CTRL pin.
Clock buffer	Yes		Differential clock	~ 1mA	n/a	Single ended clock input saves ~ 1mA compared to differential. Some programmability is available through the REFBUF/CTRL pin.
Output interface drivers	Yes	-	Enabled	varies	n/a	Depending on output interface mode, unused output drivers is powered down for maximum power savings
Decimation filter	Yes	-	Disabled	see Electrical table	n/a	

### 7.4.3 Digital Channel Averaging

The ADC3683-xEP includes a digital channel averaging feature which enables improvement of the ADC dynamic range (see [Figure 7-48](#)). The same input signal is given to both ADC inputs externally and the output of the two ADCs is averaged internally. By averaging, uncorrelated noise (that is, ADC thermal noise) improves 3dB while correlated noise (that is, jitter in the clock path, reference noise) is unaffected. Therefore, the averaging gives close to 3dB improvement at low input frequencies but less at high input frequencies where clock jitter dominates the SNR.

The output from the digital averaging block is given out on the digital outputs of channel A or alternatively is routed to the digital decimation filters using the digital mux.



**Figure 7-48. Digital Channel Averaging Diagram**

## 7.5 Programming

The device is primarily configured and controlled using the serial programming interface (SPI); however, the device can operate in a default configuration without requiring the SPI interface. Also, the power down function and internal or external reference configuration is possible via pin control (PDN/SYNC and REFBUF/CTRL pin).

### Note

The power down command (via PIN or SPI) only goes in effect with the ADC sampling clock present.

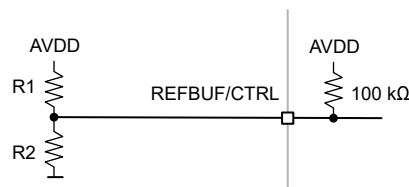
After initial power up, the default operating configuration for each device is shown in [Table 7-10](#).

**Table 7-10. Default device configuration after power up**

FEATURE	ADC3683-xEP
Signal Input	Differential
Auto-zero	Disabled
Clock Input	Differential
Reference	External
Decimation	DDC bypass
Interface	2-wire
Output Format	2s complement

### 7.5.1 Configuration using PINs only

The ADC voltage reference is selected using the REFBUF/CTRL pin. Even though there is an internal 100kΩ pull-up resistor to AVDD, the REFBUF/CTRL pin should be set to a voltage externally and not left floating. When using a voltage divider to set the REFBUF/CTRL voltage (R1 and R2 in [Figure 7-49](#)), resistor values < 5kΩ are used.



**Figure 7-49. Configuration of external voltage on REFBUF/CTRL pin**

**Table 7-11. REFBUF/CTRL voltage levels control voltage reference selection**

REFBUF/CTRL VOLTAGE	VOLTAGE REFERENCE OPTION	CLOCKING OPTION
> 1.7V (Default)	External reference	Differential clock input
1.2V (1.15-1.25V)	External 1.2V input on REFBUF/CTRL pin using internal gain buffer	Differential clock input
0.5 - 0.7V	Internal reference	Differential clock input
< 0.1V	Internal reference	Single ended clock input

### 7.5.2 Configuration using the SPI interface

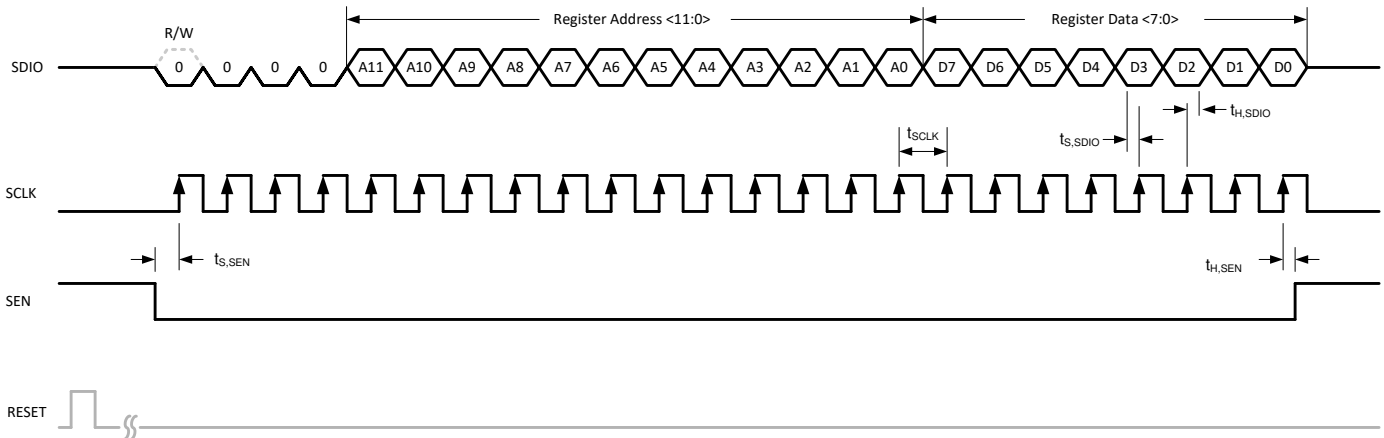
The device has a set of internal registers that are accessed by the serial interface formed by the SEN (serial interface enable), SCLK (serial interface clock) and SDIO (serial interface data input/output) pins. Serially shifting bits into the device is enabled when SEN is low. Serial data input are latched at every SCLK rising edge when SEN is active (low). The serial data are loaded into the register at every 24th SCLK rising edge when SEN is low. When the word length exceeds a multiple of 24 bits, the excess bits are ignored. Data is loaded in multiples of 24-bit words within a single active SEN pulse. The interface can function with SCLK frequencies from 12MHz down to very low speeds (of a few hertz) and also with a non-50% SCLK duty cycle.

### 7.5.2.1 Register Write

The internal registers are programmed following these steps:

1. Drive the SEN pin low
2. Set the R/W bit to 0 (bit A15 of the 16-bit address) and bits A[14:12] in address field to 0.
3. Initiate a serial interface cycle by specifying the address of the register (A[11:0]) whose content is written and
4. Write the 8-bit data that are latched in on the SCLK rising edges

Figure 7-50 shows the timing requirements for the serial register write operation.

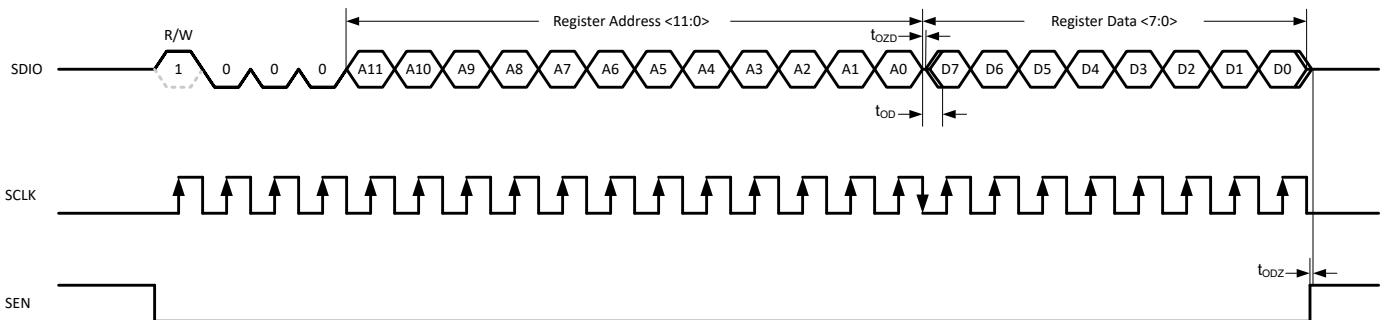


**Figure 7-50. Serial Register Write Timing Diagram**

### 7.5.2.2 Register Read

The device includes a mode where the contents of the internal registers are read back using the SDIO pin. This readback mode is useful as a diagnostic check to verify the serial interface communication between the external controller and the ADC. The procedure to read the contents of the serial registers is as follows:

1. Drive the SEN pin low
2. Set the R/W bit (A15) to 1. This setting disables any further writes to the registers. Set A[14:12] in address field to 0.
3. Initiate a serial interface cycle specifying the address of the register (A[11:0]) whose content is read
4. The device launches the contents (D[7:0]) of the selected register on the SDIO pin on SCLK falling edge
5. The external controller can capture the contents on the SCLK rising edge



**Figure 7-51. Serial Register Read Timing Diagram**

## 8 Application Information Disclaimer

### Note

Information in the following applications sections is not part of the TI component specification, and TI does not warrant its accuracy or completeness. TI's customers are responsible for determining suitability of components for their purposes, as well as validating and testing their design implementation to confirm system functionality.

### 8.1 Application Information

A spectrum analyzer is a typical frequency domain application for the ADC3683-xEP and the front end circuitry is similar to several other systems such as software defined radio (SDR), sonar, radar or communications. Some applications require frequency coverage including DC or near DC (such as, sonar), which is included in this example.

(4)

### 8.2 Typical Application

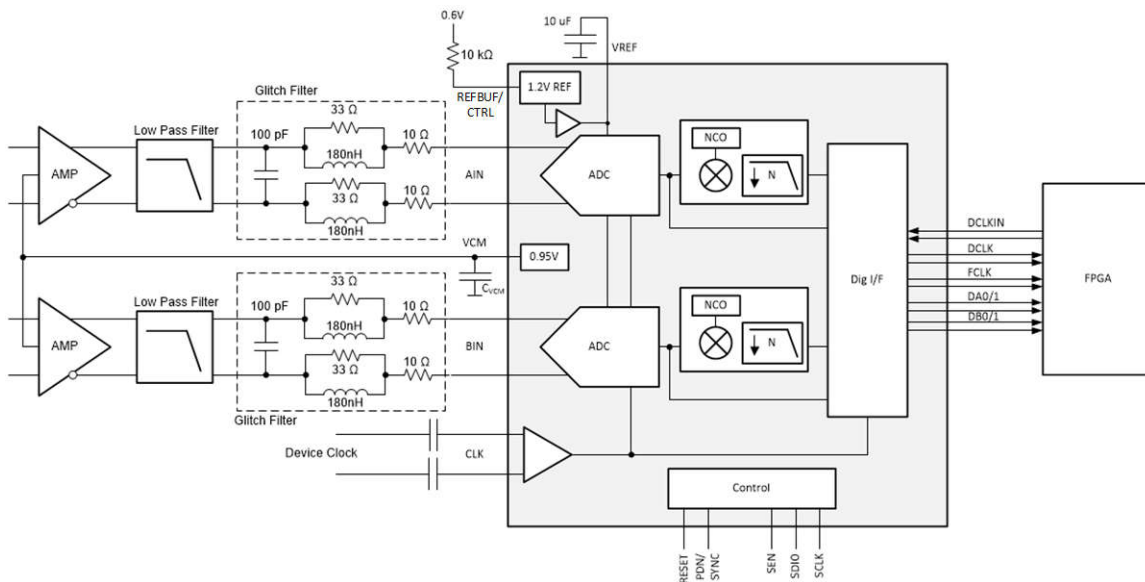


Figure 8-1. Typical configuration for a spectrum analyzer with DC support

### 8.2.1 Design Requirements

Frequency domain applications cover a wide range of frequencies from low input frequencies at or near DC in the 1st Nyquist zone to under sampling in higher Nyquist zones. If low input frequency is supported, then the input has to be DC coupled and the ADC driven by a fully differential amplifier (FDA). If low frequency support is not needed, then AC coupling and use of a balun is more suitable.

The internal reference is used since DC precision is not needed. However, the ADC AC performance is dependent on the quality of the external clock source. If in-band interferes are present, then the ADC SFDR performance is a key care about. A higher ADC sampling rate is desirable to relax the external anti-aliasing filter. An internal decimation filter is used to reduce the digital output rate afterwards.

**Table 8-1. Design key care-about**

FEATURE	DESCRIPTION
Signal Bandwidth	DC to 20MHz
Input Driver	Single ended to differential signal conversion and DC coupling
Clock Source	External clock with low jitter

When designing the amplifier or filter driving circuit, the ADC input full-scale voltage needs to be considered. For example, the ADC3683-xEP input full-scale is 3.2Vpp. When factoring in approximately 1dB for insertion loss of the filter, then the amplifier needs to deliver close to 3.6Vpp. The amplifier distortion performance degrades with a larger output swing and considering the ADC common mode input voltage the amplifier may not be able to deliver the full swing. The ADC3683-xEP provides an output common mode voltage of 0.95V and the THS4541 for example can only swing within 250mV of the negative supply. A unipolar 3.3V amplifier power supply limits the maximum voltage swing to approximately 2.8Vpp. If a larger output swing is required (factoring in filter insertion loss), then a negative supply for the amplifier is needed to eliminate that limitation. Additionally, input voltage protection diodes are needed to protect the ADC from over-voltage events.

**Table 8-2. Output voltage swing of THS4541 vs power supply**

DEVICE	MIN OUTPUT VOLTAGE	MAX SWING WITH 3.3V/ 0V SUPPLY	MAX SWING WITH 3.3V/ -1.V SUPPLY
THS4541	VS- + 250mV	2.8Vpp	6.8Vpp

### 8.2.2 Detailed Design Procedure

#### 8.2.2.1 Input Signal Path

Depending on desired input signal frequency range the THS4551 and THS4541 provide good low power options to drive the ADC inputs. [Table 8-3](#) provides a comparison between the THS4551 and THS4541 and the power consumption vs usable frequency trade off.

**Table 8-3. Fully Differential Amplifier Options**

DEVICE	CURRENT (IQ) PER CHANNEL	USABLE FREQUENCY RANGE
THS4561	0.8mA	< 3MHz
THS4551	1.4mA	< 10MHz
THS4541	10mA	< 70MHz

The low pass filter design (topology, filter order) is driven by the application itself. However, when designing the low pass filter, the optimum load impedance for the amplifier is taken into consideration as well. Between the low pass filter and the ADC input, the sampling glitch filter needs to be added as shown in [Section 7.3.1.2.1](#). In this example, the DC - 30MHz glitch filter is selected.

### 8.2.2.2 Sampling Clock

Applications operating with low input frequencies (such as DC to 20MHz) typically are less sensitive to performance degradation due to clock jitter. The internal ADC aperture jitter improves with faster rise and fall times (that is, square wave vs sine wave). [Table 8-4](#) provides an overview of the estimated SNR performance of the ADC3683-xEP based on different amounts of jitter of the external clock source. The SNR is estimated based on ADC3683-xEP thermal noise of 84.2dBFS and input signal at -1dBFS.

Termination of the clock input should be considered for long clock traces.

**Table 8-4. ADC SNR performance across vs input frequency for different amounts of external clock jitter**

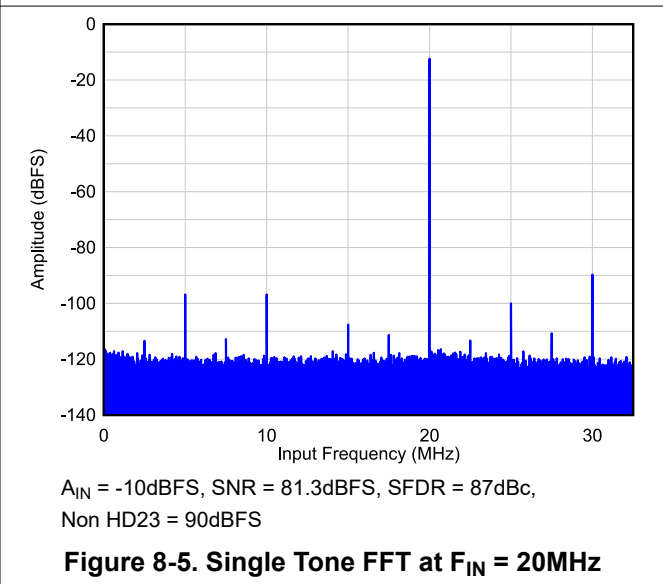
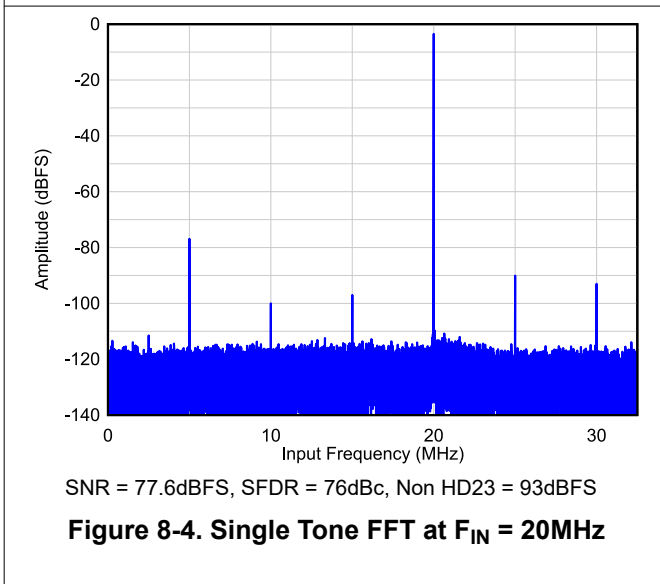
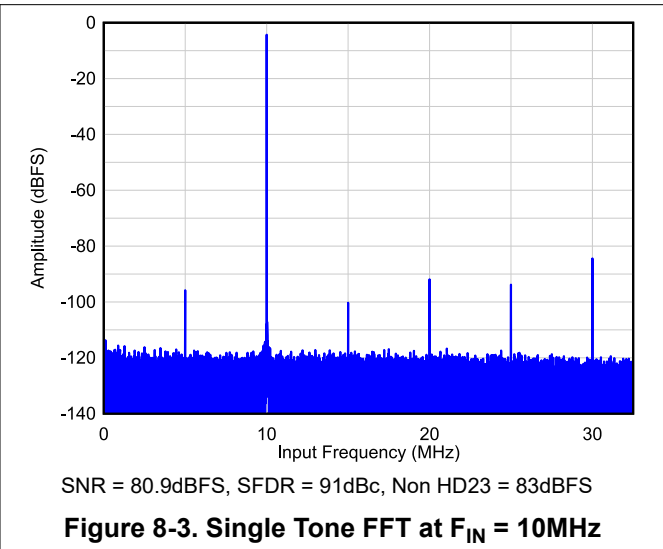
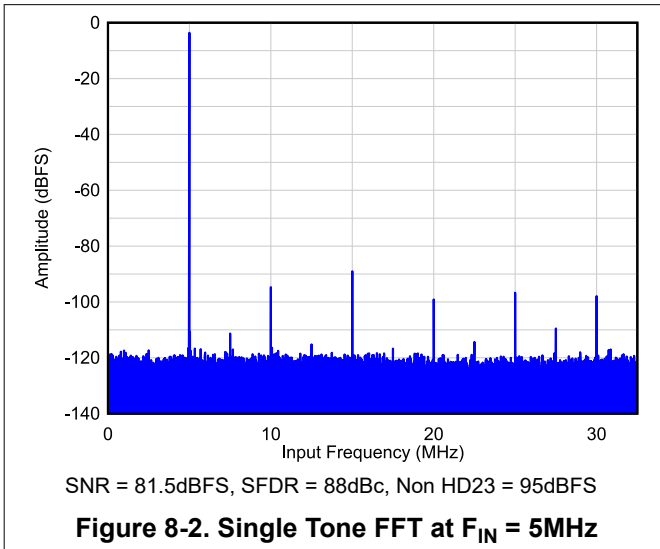
INPUT FREQUENCY	T <sub>J,EXT</sub> = 100fs	T <sub>J,EXT</sub> = 250fs	T <sub>J,EXT</sub> = 500fs	T <sub>J,EXT</sub> = 1ps
5 MHz	84.2	84.1	83.9	83.4
10 MHz	84.0	83.9	83.3	81.5
20 MHz	83.6	83.0	81.3	77.8

### 8.2.2.3 Voltage Reference

The ADC3683-xEP is configured to internal reference operation by applying 0.6V to the REFBUF/CTRL pin.

### 8.2.3 Application Curves

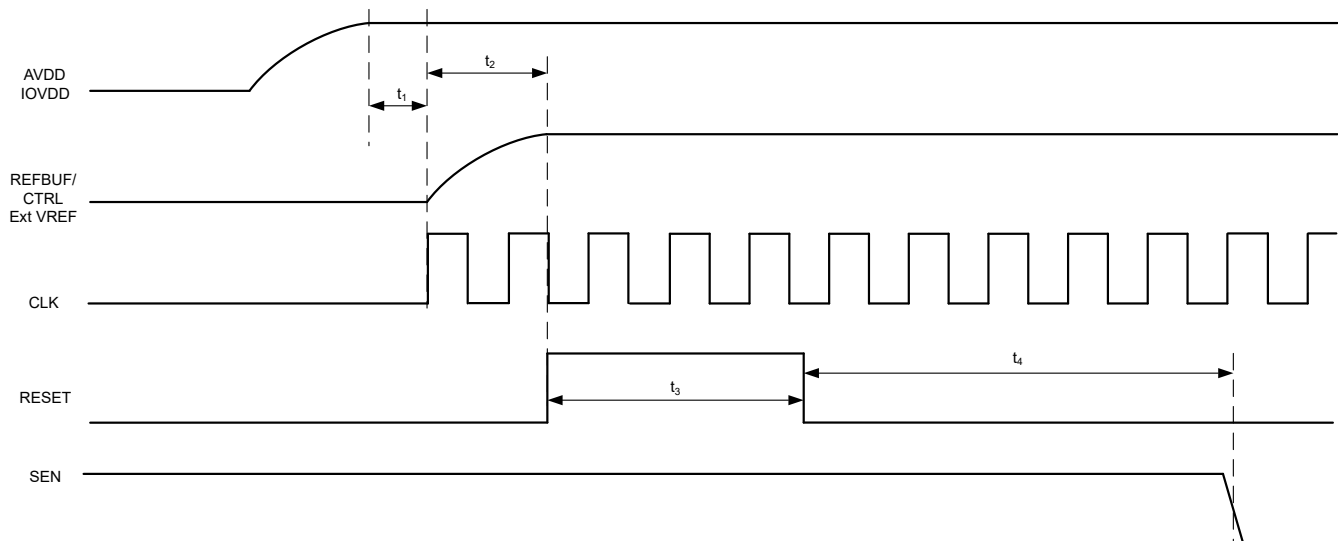
The following FFT plots show the performance of THS4541 driving the ADC3683-xEP operated at 65MSPS with a full-scale input at  $-1\text{dBFS}$  and input frequencies of 5, 10 and 20MHz.



### 8.3 Initialization Set Up

After power-up, the internal registers must be initialized to the default values through a hardware reset by applying a high pulse on the RESET pin, as shown in Figure 8-6.

1. Apply AVDD and IOVDD (no specific sequence required). After AVDD is applied, the internal bandgap reference powers up and settles out in approximately 2ms.
2. Configure REFBUF/CTRL pin (pull high or low even if configured through SPI later on) and apply the sampling clock.
3. Apply hardware reset. After hardware reset is released, the default registers are loaded from internal fuses and the internal power up capacitor calibration is initiated. The calibration takes approximately 200000 clock cycles.
4. Begin programming using the SPI interface.



**Figure 8-6. Initialization of serial registers after power up**

**Table 8-5. Power-up timing**

		MIN	TYP	MAX	UNIT
$t_1$	Power-on delay: delay from power up to logic level of REFBUF/CTRL pin	2			ms
$t_2$	Delay from REFBUF/CTRL pin logic level to RESET rising edge	100			ns
$t_3$	RESET pulse width	1			us
$t_4$	Delay from RESET disable to SEN active	~ 200000			clock cycles

#### 8.3.1 Register Initialization During Operation

If required, the serial interface registers are cleared and reset to default settings during operation either:

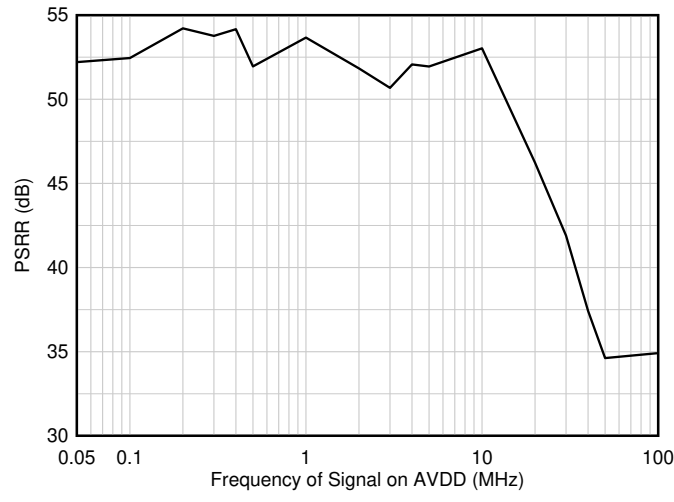
- through a hardware reset or
- by applying a software reset. When using the serial interface, set the RESET bit (D0 in register address 0x00) high. This setting initializes the internal registers to the default values, and then self-resets the RESET bit low. The RESET pin is kept low.

After hardware or software reset, the wait time is approximately 200000 clock cycles before the SPI registers are programmed.

## 8.4 Power Supply Recommendations

The ADC3683-xEP requires two different power-supplies. The AVDD rail provides power for the internal analog circuits and the ADC itself while the IOVDD rail powers the digital interface and the internal digital circuits like decimation filter or output interface mapper. Power sequencing is not required.

The AVDD power supply must be low noise to achieve data sheet performance. In applications operating near DC, the 1/f noise contribution of the power supply needs to be considered as well. The ADC is designed for good PSRR which aides with the power supply filter design.



**Figure 8-7. Power supply rejection ratio (PSRR) vs frequency**

There are two recommended power-supply architectures:

1. Step down using high-efficiency switching converters, followed by a second stage of regulation using a low noise LDO to provide switching noise reduction and improved voltage accuracy.
2. Directly step down the final ADC supply voltage using high-efficiency switching converters. This approach provides the best efficiency, but care must be taken to make sure switching noise is minimized to prevent degraded ADC performance.

TI WEBENCH® Power Designer are used to select and design the individual power-supply elements needed: see the WEBENCH® Power Designer

Recommended switching regulators for the first stage include the TPS7H4010-SEP, and similar devices.

Recommended low dropout (LDO) linear regulators include the TPS73801-SE, TPS7H1111-SEP, and similar devices.

For the switch regulator only approach, the ripple filter must be designed with a notch frequency that aligns with the switching ripple frequency of the DC/DC converter. Note the switching frequency reported from WEBENCH® and design the EMI filter and capacitor combination to have the notch frequency centered as needed. [Figure 8-8](#) and [Figure 8-9](#) illustrate the two approaches.

AVDD and IOVDD supply voltages should not be shared to prevent digital switching noise from coupling into the analog signal chain.

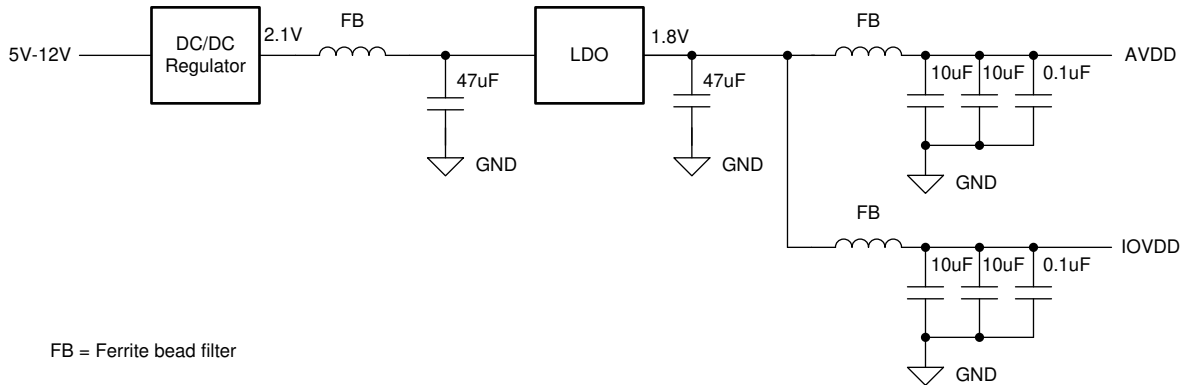


Figure 8-8. Example: LDO Linear Regulator Approach

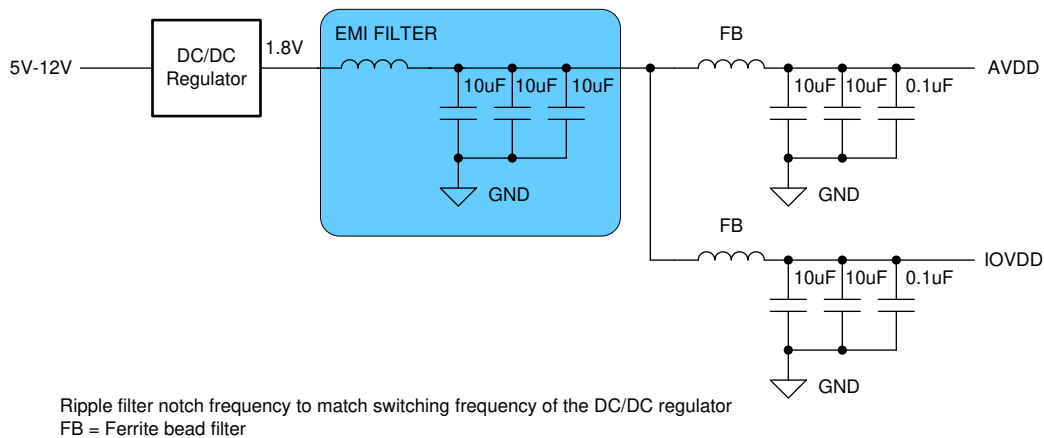


Figure 8-9. Example Switcher-Only Approach

## 8.5 Layout

### 8.5.1 Layout Guidelines

There are several critical signals which require specific care during board design:

1. Analog input and clock signals
  - Traces should be as short as possible and vias should be avoided where possible to minimize impedance discontinuities.
  - Traces should be routed using loosely coupled 100Ω differential traces.
  - Differential trace lengths are matched as close as possible to minimize phase imbalance and HD2 degradation.
2. Digital output interface
  - Traces are routed using tightly coupled 100Ω differential traces.
3. Voltage reference
  - The bypass capacitor is placed as close to the device pins as possible, and connected between VREF and REFGND on top layer avoiding vias.
  - Depending on configuration, an additional bypass capacitor between REFBUF/CTRL and REFGND is recommended, and is placed as close to pins as possible on the top layer.
4. Power and ground connections
  - Provide low resistance connection paths to all power and ground pins.
  - Use power and ground planes instead of traces.
  - Avoid narrow, isolated paths which increase the connection resistance.
  - Use a signal, ground, or power circuit board stack up to maximize coupling between the ground and power plane.

### 8.5.2 Layout Example

The following screen shot shows the top layer of the ADC3683EVM.

- Signal and clock inputs are routed as differential signals on the top layer avoiding vias.
- SLVDS output interface lanes are routed differential and length matched
- Bypass caps are close to the VREF pin on the top layer avoiding vias.

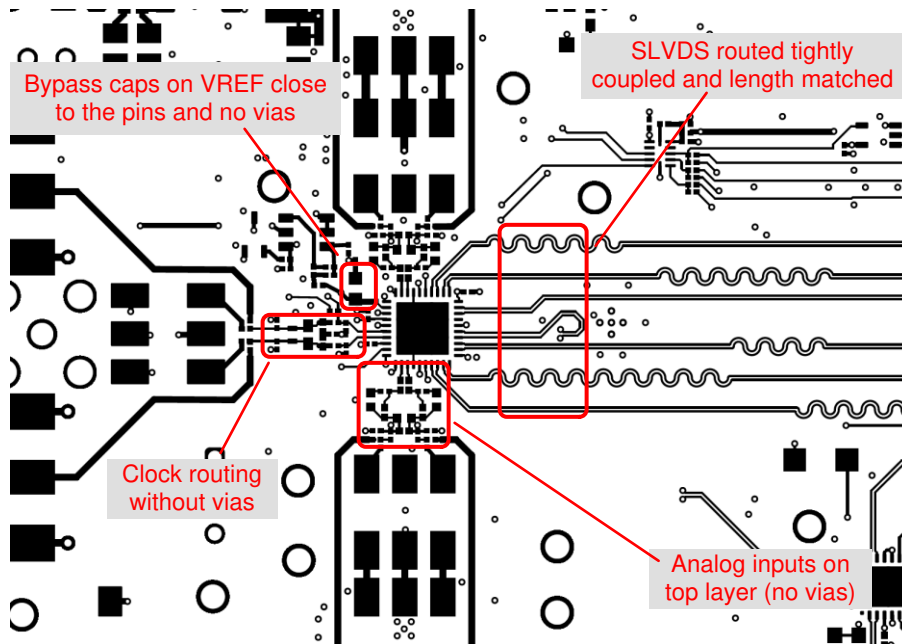


Figure 8-10. Layout example: top layer of ADC3683EVM

## 9 Register Map

**Table 9-1. Register Map Summary**

REGISTER ADDRESS	REGISTER DATA							
	D7	D6	D5	D4	D3	D2	D1	D0
0x00	0	0	0	0	0	0	0	RESET
0x07	OP IF MAPPER			0	OP IF EN	OP IF SEL		
0x08	0	0	PDN CLKBUF	PDN REFAMP	0	PDN A	PDN B	PDN GLOBAL
0x09	0	0	PDN FCLKOUT	PDN DCLKOUT	PDN DA1	PDN DA0	PDN DB1	PDN DB0
0x0D	0	0	0	0	MASK CLKBUF	MASK REFAMP	MASK BG DIS	0
0x0E	SYNC PIN EN	SPI SYNC	SPI SYNC EN	0	REF CTRL	REF SEL		SE CLK EN
0x11	0	0	0	0	0	DLL PDN	0	AZ EN
0x13	0	0	0	0	0	0	0	E-FUSE LD
0x14	CUSTOM PAT [7:0]							
0x15	CUSTOM PAT [15:8]							
0x16	TEST PAT B			TEST PAT A			CUSTOM PAT [17:16]	
0x19	FCLK SRC	0	0	FCLK DIV	0	0	0	TOG FCLK
0x1A	0	LVDS ½ SWING	0	0	0	0	0	0
0x1B	MAPPER EN	20B EN	BIT MAPPER RES			0	0	0
0x1E	0	0	0	0	LVDS DATA DEL		LVDS DCLK DEL	
0x20	FCLK PAT [7:0]							
0x21	FCLK PAT [15:8]							
0x22	0	SCR EN	0	0	FCLK PAT [19:16]			
0x24	0	0	CH AVG EN	DDC MUX		DIG BYP	DDC EN	0
0x25	DDC MUX EN	DECIMATION			REAL OUT	0	0	MIX PHASE
0x26	MIX GAIN A		MIX RES A	FS/4 MIX A	MIX GAIN B		MIX RES B	FS/4 MIX B
0x27	0	0	0	OP ORDER A	Q-DEL A	FS/4 MIX PH A	0	0
0x2A	NCO A [7:0]							
0x2B	NCO A [15:8]							
0x2C	NCO A [23:16]							
0x2D	NCO A [31:24]							
0x2E	0	0	0	OP ORDER B	Q-DEL B	FS/4 MIX PH B	0	0
0x31	NCO B [7:0]							
0x32	NCO B [15:8]							
0x33	NCO B [23:16]							
0x34	NCO B [31:24]							
0x39..0x60	OUTPUT BIT MAPPER CHA							
0x61..0x88	OUTPUT BIT MAPPER CHB							
0x8F	0	0	0	0	0	0	FORMAT A	0
0x92	0	0	0	0	0	0	FORMAT B	0

## 9.1 Detailed Register Description

**Figure 9-1. Register 0x00**

7	6	5	4	3	2	1	0
0	0	0	0	0	0	0	RESET
R/W-0	R/W-0	R/W-0	R/W-0	R/W-0	R/W-0	R/W-0	R/W-0

**Table 9-2. Register 0x00 Field Descriptions**

Bit	Field	Type	Reset	Description
7-1	0	R/W	0	Must write 0
0	RESET	R/W	0	This bit resets all internal registers to the default values and self clears to 0.

**Figure 9-2. Register 0x07**

7	6	5	4	3	2	1	0
OP IF MAPPER			0	OP IF EN	OP IF SEL		
R/W-0	R/W-0	R/W-0	R/W-0	R/W-0	R/W-0	R/W-0	R/W-0

**Table 9-3. Register 0x07 Field Descriptions**

Bit	Field	Type	Reset	Description
7-5	OP IF MAPPER	R/W	000	Output interface mapper. This register contains the proper output interface bit mapping for the different interfaces. The interface bit mapping is internally loaded from e-fuses and also requires a fuse load command to go into effect (0x13, D0). Register 0x07 along with the E-Fuse Load (0x13, D0) needs to be loaded first in the programming sequence since the E-Fuse load resets the SPI writes. After initial reset the default output interface variant is loaded automatically from fuse internally. However, when reading back this register reads 000 until a value is written using SPI. 001: 2-wire, 18 and 14-bit 010: 2-wire, 16-bit 011: 1-wire 100: 0.5-wire others: not used
4	0	R/W	0	Must write 0
3	OP IF EN	R/W	0	Enables changing the default output interface mode (D2-D0).
2-0	OP IF SEL	R/W	000	Selection of the output interface mode. OP IF EN (D3) needs to be enabled also. After initial reset the default output interface is loaded automatically from fuse internally. However, when reading back this register reads 000 until a value is written using SPI. 011: 2-wire 100: 1-wire 101: 0.5-wire others: not used

**Figure 9-3. Register 0x08**

7	6	5	4	3	2	1	0
0	0	PDN CLKBUF	PDN REFAMP	0	PDN A	PDN B	PDN GLOBAL
R/W-0	R/W-0	R/W-0	R/W-0	R/W-0	R/W-0	R/W-0	R/W-0

**Table 9-4. Register 0x08 Field Descriptions**

Bit	Field	Type	Reset	Description
7-6	0	R/W	0	Must write 0
5	PDN CLKBUF	R/W	0	Powers down sampling clock buffer 0: Clock buffer enabled 1: Clock buffer powered down
4	PDN REFAMP	R/W	0	Powers down internal reference gain amplifier 0: REFAMP enabled 1: REFAMP powered down
3	0	R/W	0	Must write 0
2	PDN A	R/W	0	Powers down ADC channel A 0: ADC channel A enabled 1: ADC channel A powered down
1	PDN B	R/W	0	Powers down ADC channel B 0: ADC channel B enabled 1: ADC channel B powered down
0	PDN GLOBAL	R/W	0	Global power down via SPI 0: Global power disabled 1: Global power down enabled. Power down mask (register 0x0D) determines which internal blocks are powered down.

**Figure 9-4. Register 0x09**

7	6	5	4	3	2	1	0
0	0	PDN FCLKOUT	PDN DCLKOUT	PDN DA1	PDN DA0	PDN DB1	PDN DB0
R/W-0	R/W-0	R/W-0	R/W-0	R/W-0	R/W-0	R/W-0	R/W-0

**Table 9-5. Register 0x09 Field Descriptions**

Bit	Field	Type	Reset	Description
7-6	0	R/W	0	Must write 0
5	PDN FCLKOUT	R/W	0	Powers down frame clock (FCLK) LVDS output buffer 0: FCLK output buffer enabled 1: FCLK output buffer powered down
4	PDN DCLKOUT	R/W	0	Powers down DCLK LVDS output buffer 0: DCLK output buffer enabled 1: DCLK output buffer powered down
3	PDN DA1	R/W	0	Powers down LVDS output buffer for channel A, lane 1. NOT powered down automatically in 1-wire and 1/2-wire mode. 0: DA1 LVDS output buffer enabled 1: DA1 LVDS output buffer powered down
2	PDN DA0	R/W	0	Powers down LVDS output buffer for channel A, lane 0. 0: DA0 LVDS output buffer enabled 1: DA0 LVDS output buffer powered down
1	PDN DB1	R/W	0	Powers down LVDS output buffer for channel B, lane 1. NOT powered down automatically in 1-wire and 1/2-wire mode. 0: DB1 LVDS output buffer enabled 1: DB1 LVDS output buffer powered down
0	PDN DB0	R/W	0	Powers down LVDS output buffer for channel B, lane 0. NOT powered down automatically in 1/2-wire mode. 0: DB0 LVDS output buffer enabled 1: DB0 LVDS output buffer powered down

**Figure 9-5. Register 0x0D (PDN GLOBAL MASK)**

7	6	5	4	3	2	1	0
0	0	0	0	MASK CLKBUF	MASK REFAMP	MASK BG DIS	0
R/W-0	R/W-0	R/W-0	R/W-0	R/W-0	R/W-0	R/W-0	R/W-0

**Table 9-6. Register 0x0D Field Descriptions**

Bit	Field	Type	Reset	Description
7-4	0	R/W	0	Must write 0
3	MASK CLKBUF	R/W	0	Global power down mask control for sampling clock input buffer. 0: Clock buffer will get powered down when global power down is exercised. 1: Clock buffer will NOT get powered down when global power down is exercised.
2	MASK REFAMP	R/W	0	Global power down mask control for reference amplifier. 0: Reference amplifier will get powered down when global power down is exercised. 1: Reference amplifier will NOT get powered down when global power down is exercised.
1	MASK BG DIS	R/W	0	Global power down mask control for internal 1.2V bandgap voltage reference. Setting this bit reduces power consumption in global power down mode but increases the wake up time. See the power down option overview. 0: Internal 1.2V bandgap voltage reference will NOT get powered down when global power down is exercised. 1: Internal 1.2V bandgap voltage reference will get powered down when global power down is exercised.
0	0	R/W	0	Must write 0

**Figure 9-6. Register 0x0E**

7	6	5	4	3	2	1	0
SYNC PIN EN	SPI SYNC	SPI SYNC EN	0	REF CTL	REF SEL		SE CLK EN
R/W-0	R/W-0	R/W-0	R/W-0	R/W-0	R/W-0	R/W-0	R/W-0

**Table 9-7. Register 0x0E Field Descriptions**

Bit	Field	Type	Reset	Description
7	SYNC PIN EN	R/W	0	This bit controls the functionality of the SYNC/PDN pin. 0: SYNC/PDN pin exercises global power down mode when pin is pulled high. 1: SYNC/PDN pin issues the SYNC command when pin is pulled high.
6	SPI SYNC	R/W	0	toggling this bit issues the SYNC command using the SPI register write. SYNC using SPI must be enabled as well (D5). This bit doesn't self reset to 0. 0: Normal operation 1: SYNC command issued.
5	SPI SYNC EN	R/W	0	This bit enables synchronization using SPI instead of the SYNC/PDN pin. 0: Synchronization using SPI register bit disabled. 1: Synchronization using SPI register bit enabled.
4	0	R/W	0	Must write 0
3	REF CTL	R/W	0	This bit determines if the REFBUF/CTRL pin controls the voltage reference selection or the SPI register (D2-D1). 0: The REFBUF/CTRL pin selects the voltage reference option. 1: Voltage reference is selected using SPI (D2-D1) and single ended clock using D0.
2-1	REF SEL	R/W	00	Selects of the voltage reference option. REF CTRL (D3) must be set to 1. 00: Internal reference 01: External voltage reference (1.2V) using internal reference buffer (REFBUF/CTRL) 10: External voltage reference 11: not used
0	SE CLK EN	R/W	0	Selects single ended clock input and powers down the differential sampling clock input buffer. REF CRTL (D3) must be set to 1. 0: Differential clock input 1: Single ended clock input

**Figure 9-7. Register 0x11**

7	6	5	4	3	2	1	0
0	0	0	0	0	DLL PDN	0	AZ EN
R/W-0	R/W-0	R/W-0	R/W-0	R/W-0	R/W-0	R/W-0	R/W-0

**Table 9-8. Register 0x11 Field Descriptions**

Bit	Field	Type	Reset	Description
7-3	0	R/W	0	Must write 0
2	DLL PDN	R/W	0	This register applies ONLY to the ADC3683. It powers down the internal DLL, which is used to adjust the sampling time. This register must only be enabled when operating at sampling rates below 40 MSPS. When DLL PDN bit is enabled the sampling time is directly dependent on sampling clock duty cycle (with a 50/50 duty the sampling time is $T_S/2$ ). 0: Sampling time is $T_S/4$ 1: Sampling time is $T_S/2$ (only for sampling rates below 40 MSPS).
1	0	R/W	0	Must write 0
0	AZ EN	R/W	0	This bit enables the internal auto-zero circuitry. It is disabled by default for the ADC3683-xEP. 0: Auto-zero disabled 1: Auto-zero enabled

**Figure 9-8. Register 0x13**

7	6	5	4	3	2	1	0
0	0	0	0	0	0		E-FUSE LD
R/W-0	R/W-0	R/W-0	R/W-0	R/W-0	R/W-0	R/W-0	R/W-0

**Table 9-9. Register 0x13 Field Descriptions**

Bit	Field	Type	Reset	Description
7-1	0	R/W	0	Must write 0
0	E-FUSE LD	R/W	0	This register bit loads the internal bit mapping for different interfaces. After setting the interface in register 0x07, this E-FUSE LD bit needs to be set to 1 and reset to 0 for loading to go into effect. Register 0x07 along with the E-Fuse Load (0x13, D0) needs to be loaded first in the programming sequence since the E-Fuse load resets the SPI writes. 0: E-FUSE LOAD set 1: E-FUSE LOAD reset

**Figure 9-9. Register 0x14/15/16**

7	6	5	4	3	2	1	0
CUSTOM PAT [7:0]							
CUSTOM PAT [15:8]							
TEST PAT B			TEST PAT A			CUSTOM PAT [17:16]	
R/W-0	R/W-0	R/W-0	R/W-0	R/W-0	R/W-0	R/W-0	R/W-0

**Table 9-10. Register 0x14/15/16 Field Descriptions**

Bit	Field	Type	Reset	Description
7-0	CUSTOM PAT [17:0]	R/W	00000000	<p>This register is used for two purposes:</p> <ul style="list-style-type: none"> <li>It sets the constant custom pattern starting from MSB</li> <li>It sets the RAMP pattern increment step size.</li> </ul> <p>00001: Ramp pattern for 18-bit ADC 00100: Ramp pattern for 16-bit ADC 10000: Ramp pattern for 14-bit ADC</p>
7-5	TEST PAT B	R/W	000	<p>Enables test pattern output mode for channel B (NOTE: The test pattern is set prior to the bit mapper and is based on native resolution of the ADC starting from the MSB). These work in either output format.</p> <p>000: Normal output mode (test pattern output disabled) 010: Ramp pattern: need to set proper increment using CUSTOM PAT register 011: Constant Pattern using CUSTOM PAT [17:0] in register 0x14/15/16. others: not used</p>
4-2	TEST PAT A	R/W	000	<p>Enables test pattern output mode for channel A (NOTE: The test pattern is set prior to the bit mapper and is based on native resolution of the ADC starting from the MSB). These work in either output format.</p> <p>000: Normal output mode (test pattern output disabled) 010: Ramp pattern: need to set proper increment using CUSTOM PAT register 011: Constant Pattern using CUSTOM PAT [17:0] in register 0x14/15/16. others: not used</p>

**Figure 9-10. Register 0x19**

7	6	5	4	3	2	1	0
FCLK SRC	0	0	FCLK DIV	0	0	0	TOG FCLK
R/W-0	R/W-0	R/W-0	R/W-0	R/W-0	R/W-0	R/W-0	R/W-0

**Table 9-11. Register 0x19 Field Descriptions**

Bit	Field	Type	Reset	Description
7	FCLK SRC	R/W	0	User has to select if FCLK signal comes from ADC or from DDC block. Here real decimation is treated same as bypass mode 0: FCLK generated from ADC. FCLK SRC set to 0 for DDC bypass, real decimation mode and 1/2-w complex decimation mode. 1: FCLK generated from DDC block. In complex decimation mode only this bit needs to be set for 2-w and 1-w output interface mode but NOT for 1/2-w mode.
6-5	0	R/W	0	Must write 0
4	FCLK DIV	R/W	0	This bit needs to be set to 1 for 2-w output mode in bypass/real decimation mode only . 0: All output interface modes except 2-w decimation bypass and real decimation mode. 1: 2-w output interface mode for decimation bypass and real decimation.
3-1	0	R/W	0	Must write 0
0	TOG FCLK	R/W	0	This bit adjusts the FCLK signal appropriately for 1/2-wire mode where FCLK is stretched to cover channel A and channel B. This bit ONLY needs to be set in 1/2-wire mode with complex decimation mode. 0: all other modes. 1: FCLK for 1/2-wire complex decimation mode.

**Table 9-12. Configuration of FCLK SRC and FCLK DIV Register Bits vs Serial Interface**

BYPASS/DECIMATION	SERIAL INTERFACE	FCLK SRC	FCLK DIV	TOG FCLK
Decimation Bypass/ Real Decimation	2-wire	0	1	0
	1-wire	0	0	0
	1/2-wire	0	0	0
Complex Decimation	2-wire	1	0	0
	1-wire	1	0	0
	1/2-wire	0	0	1

**Figure 9-11. Register 0x1A**

7	6	5	4	3	2	1	0
0	LVDS ½ SWING	0	0	0	0	0	0
R/W-0	R/W-0	R/W-0	R/W-0	R/W-0	R/W-0	R/W-0	R/W-0

**Table 9-13. Register 0x1A Field Descriptions**

Bit	Field	Type	Reset	Description
7	0	R/W	0	Must write 0
6	LVDS ½ SWING	R/W	0	This bit reduces the LVDS output current from 3.5mA to 1.75mA which reduces power consumption.
5-0	0	R/W	0	Must write 0

**Figure 9-12. Register 0x1B**

7	6	5	4	3	2	1	0
MAPPER EN	20B EN	BIT MAPPER RES			0	0	0
R/W-0	R/W-0	R/W-0	R/W-0	R/W-0	R/W-0	R/W-0	R/W-0

**Table 9-14. Register 0x1B Field Descriptions**

Bit	Field	Type	Reset	Description
7	MAPPER EN	R/W	0	This bit enables changing the resolution of the output (including output serialization factor) in bypass mode only. This bit is not needed for 20-bit resolution output. 0: Output bit mapper disabled. 1: Output bit mapper enabled.
6	20B EN	R/W	0	This bit enables 20-bit output resolution which can be useful for very high decimation settings so that quantization noise doesn't impact the ADC performance. 0: 20-bit output resolution disabled. 1: 20-bit output resolution enabled.
5-3	BIT MAPPER RES	R/W	000	Sets the output resolution using the bit mapper. MAPPER EN bit (D6) needs to be enabled when operating in bypass mode.. 000: 18 bit 001: 16 bit 010: 14 bit all others, n/a
2-0	0	R/W	0	Must write 0

**Table 9-15. Register Settings for Output Bit Mapper vs Operating Mode**

BYPASS/DECIMATION	OUTPUT RESOLUTION	MAPPER EN (D7)	BIT MAPPER RES (D5-D3)
Decimation Bypass	Resolution Change	1	000: 18-bit 001: 16-bit 010: 14-bit
Real Decimation	Resolution Change (default 18-bit)	0	
Complex Decimation		0	

**Figure 9-13. Register 0x1E**

7	6	5	4	3	2	1	0
0	0	0	0	LVDS DATA DEL		LVDS DCLK DEL	
R/W-0	R/W-0	R/W-0	R/W-0	R/W-0	R/W-0	R/W-0	R/W-0

**Table 9-16. Register 0x1E Field Descriptions**

Bit	Field	Type	Reset	Description
7-4	0	R/W	0	Must write 0
3-2	LVDS DATA DEL	R/W	00	These bits adjust the output timing of the SLVDS output data. 00: no delay 01: Data advanced by 50 ps 10: Data delayed by 50 ps 11: Data delayed by 100 ps
1-0	LVDS DCLK DEL	R/W	00	These bits adjust the output timing of the SLVDS DCLK output. 00: no delay 01: DCLK advanced by 50 ps 10: DCLK delayed by 50 ps 11: DCLK delayed by 100 ps

**Figure 9-14. Register 0x20/21/22**

7	6	5	4	3	2	1	0
FCLK PAT [7:0]							
FCLK PAT [15:8]							
0	SCR EN	0	0	FCLK PAT [19:16]			
R/W-0	R/W-0	R/W-0	R/W-0	R/W-0	R/W-0	R/W-0	R/W-0

**Table 9-17. Register 0x20/21/22 Field Descriptions**

Bit	Field	Type	Reset	Description
7-0	FCLK PAT [19:0]	R/W	0xFFC00	These bits can adjust the duty cycle of the FCLK. In decimation bypass mode the FCLK pattern gets adjusted automatically for the different output resolutions. <a href="#">Table 9-18</a> shows the proper FCLK pattern values for 1-wire and 1/2-wire in real/complex decimation.
6	SCR EN	R/W	0	This bit enables the output data scrambler. Digital bypass (0x24, D2) needs to be set as well. 0: Output scrambling disabled 1: Output scrambling enabled

**Table 9-18. FCLK Pattern for different resolution based on interface**

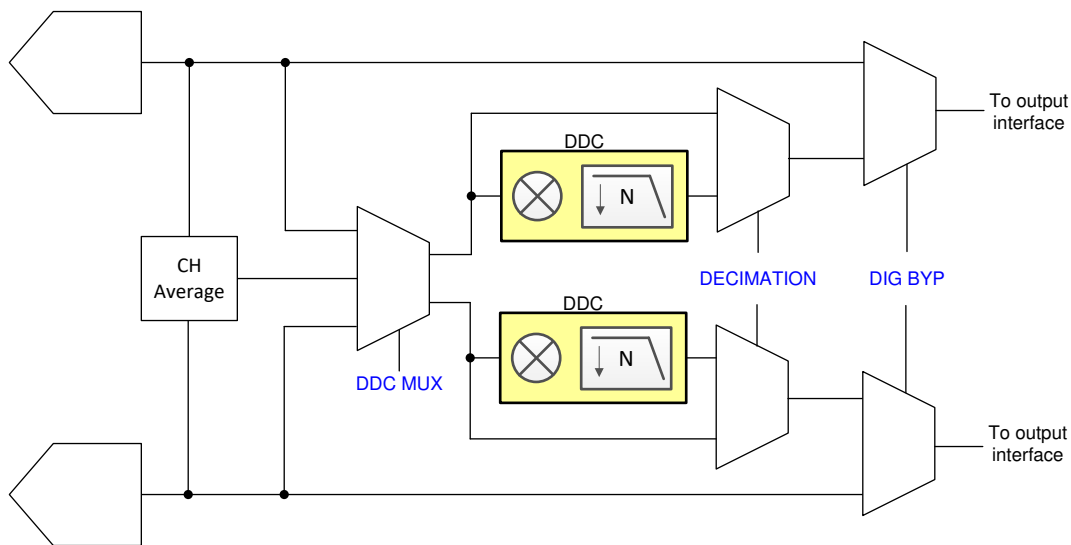
DECIMATION	OUTPUT RESOLUTION	2-WIRE	1-WIRE	1/2-WIRE	
REAL DECIMATION	14-bit	Use Default	0xFE000	Use Default	
	16-bit		0xFF000		
	18-bit		0xFF800		
	20-bit		0xFFC00		
COMPLEX DECIMATION	14-bit		0xFFFFF	0xFFFFF	0xFFFFF
	16-bit				
	18-bit				
	20-bit				

**Figure 9-15. Register 0x24**

7	6	5	4	3	2	1	0
0	0	CH AVG EN	DDC MUX		DIG BYP	DDC EN	0
R/W-0	R/W-0	R/W-0	R/W-0	R/W-0	R/W-0	R/W-0	R/W-0

**Table 9-19. Register 0x24 Field Descriptions**

Bit	Field	Type	Reset	Description
7-6	0	R/W	0	Must write 0
5	CH AVG EN	R/W	0	Averages the output of ADC channel A and channel B together. The DDC MUX has to be enabled and set to '11'. The decimation filter needs to be enabled and set to bypass (fullrate output) or decimation and DIG BYP set to 1. 0: Channel averaging feature disabled 1: Output of channel A and channel B are averaged: (A+B)/2.
4-3	DDC MUX	R/W	0	Configures DDC MUX in front of the decimation filter. 00: ADC channel A connected to DDC A; ADC Channel B connected to DDC B 01: ADC channel A connected to DDC A and DDC B. 10: ADC channel B connected to DDC A and DDC B. 11: Output of ADC averaging block (see CH AVG EN) given to DDC A and DDC B.
2	DIG BYP	R/W	0	This bit needs to be set to enable digital features block which includes decimation and scrambling. 0: Digital feature block bypassed - lowest latency 1: Data path includes digital features
1	DDC EN	R/W	0	Enables internal decimation filter for both channels 0: DDC disabled. 1: DDC enabled.
0	0	R/W	0	Must write 0



**Figure 9-16. Register control for digital features**

**Figure 9-17. Register 0x25**

7	6	5	4	3	2	1	0
DDC MUX EN	DECIMATION			REAL OUT	0	0	MIX PHASE
R/W-0	R/W-0	R/W-0	R/W-0	R/W-0	R/W-0	R/W-0	R/W-0

**Table 9-20. Register 0x25 Field Descriptions**

Bit	Field	Type	Reset	Description
7	DDC MUX EN	R/W	0	Enables the digital mux between ADCs and decimation filters. This bit is required for DDC mux settings in register 0x24 (D4, D3) to go into effect. 0: DDC mux disabled 1: DDC mux enabled
6-4	DECIMATION	R/W	000	Complex decimation setting. This applies to both channels. 000: Bypass mode (no decimation)    100: Decimation by 16 001: Decimation by 2                    101: Decimation by 32 010: Decimation by 4                    others: not used 011: Decimation by 8
3	REAL OUT	R/W	0	This bit selects real output decimation. This mode applies to both channels. In this mode, the decimation filter is a low pass filter and no complex mixing is performed to reduce power consumption. For maximum power savings the NCO in this case should be set to 0. 0: Complex decimation 1: Real decimation
2-1	0	R/W	0	Must write 0
0	MIX PHASE	R/W	0	This bit used to invert the NCO phase 0: NCO phase as is. 1: NCO phase inverted.

**Figure 9-18. Register 0x26**

7	6	5	4	3	2	1	0
MIX GAIN A		MIX RES A	FS/4 MIX A	MIX GAIN B		MIX RES B	FS/4 MIX B
R/W-0	R/W-0	R/W-0	R/W-0	R/W-0	R/W-0	R/W-0	R/W-0

**Table 9-21. Register 0x26 Field Descriptions**

Bit	Field	Type	Reset	Description
7-6	MIX GAIN A	R/W	00	This bit applies a 0, 3 or 6-dB digital gain to the output of digital mixer to compensate for the mixing loss for channel A. 00: no digital gain added 01: 3-dB digital gain added (should be enabled with real decimation) 10: 6-dB digital gain added (should be enabled with complex decimation) 11: not used
5	MIX RES A	R/W	0	Toggling this bit resets the NCO phase of channel A and loads the new NCO frequency. This bit does not self reset.
4	FS/4 MIX A	R/W	0	Enables FS/4 mixing for DDC A (complex decimation only). 0: FS/4 mixing disabled. 1: FS/4 mixing enabled.
3-2	MIX GAIN B	R/W	00	This bit applies a 0, 3 or 6-dB digital gain to the output of digital mixer to compensate for the mixing loss for channel B. 00: no digital gain added 01: 3-dB digital gain added (should be enabled with real decimation) 10: 6-dB digital gain added (should be enabled with complex decimation) 11: not used
1	MIX RES B	R/W	0	Toggling this bit resets the NCO phase of channel B and loads the new NCO frequency. This bit does not self reset.

**Table 9-21. Register 0x26 Field Descriptions (continued)**

Bit	Field	Type	Reset	Description
0	FS/4 MIX B	R/W	0	Enables FS/4 mixing for DDC B (complex decimation only). 0: FS/4 mixing disabled. 1: FS/4 mixing enabled.

**Figure 9-19. Register 0x27**

7	6	5	4	3	2	1	0
0	0	0	OP ORDER A	Q-DEL A	FS/4 MIX PH A	0	0
R/W-0	R/W-0	R/W-0	R/W-0	R/W-0	R/W-0	R/W-0	R/W-0

**Table 9-22. Register 0x27 Field Descriptions**

Bit	Field	Type	Reset	Description
7-5	0	R/W	0	Must write 0
4	OP ORDER A	R/W	0	Swaps the I and Q output order for channel A. See <a href="#">Table 9-23</a> for recommended settings. Only used with complex decimation. Set to 0 with real decimation. 0: Output order is I[n], Q[n] 1: Output order is swapped: Q[n], I[n]
3	Q-DEL A	R/W	0	This delays the Q-sample output of channel A by one. See <a href="#">Table 9-23</a> for recommended settings. Only used with complex decimation. Set to 0 with real decimation. 0: Output order is I[n], Q[n] 1: Q-sample is delayed by 1 sample: I[n], Q[n+1], I[n+1], Q[n+2]
2	FS/4 MIX PH A	R/W	0	Inverts the mixer phase for channel A when using FS/4 mixer. 0: Mixer phase is non-inverted 1: Mixer phase is inverted
1-0	0	R/W	0	Must write 0

**Table 9-23. OP-ORDER and Q-DELAY Register Settings for Complex Decimation**

SLVDS INTERFACE	OP-ORDER	Q-DELAY
2-wire	1	0
1-wire	0	1
1/2-wire	1	1

**Figure 9-20. Register 0x2A/B/C/D**

7	6	5	4	3	2	1	0
NCO A [7:0]							
NCO A [15:8]							
NCO A [23:16]							
NCO A [31:24]							
R/W-0	R/W-0	R/W-0	R/W-0	R/W-0	R/W-0	R/W-0	R/W-0

**Table 9-24. Register 0x2A/2B/2C/2D Field Descriptions**

Bit	Field	Type	Reset	Description
7-0	NCO A [31:0]	R/W	0	Sets the 32 bit NCO value for decimation filter channel A. The NCO value is $f_{NCO} \times 2^{32} / F_S$ . In real decimation mode these registers are automatically set to 0.

**Figure 9-21. Register 0x2E**

7	6	5	4	3	2	1	0
0	0	0	OP ORDER B	Q-DEL B	FS/4 MIX PH B	0	0
R/W-0	R/W-0	R/W-0	R/W-0	R/W-0	R/W-0	R/W-0	R/W-0

**Table 9-25. Register 0x2E Field Descriptions**

Bit	Field	Type	Reset	Description
7-5	0	R/W	0	Must write 0
4	OP ORDER B	R/W	0	Swaps the I and Q output order for channel B. See <a href="#">Table 9-23</a> for recommended settings. Only used with complex decimation. Set to 0 with real decimation. 0: Output order is I[n], Q[n] 1: Output order is swapped: Q[n], I[n]
3	Q-DEL B	R/W	0	This delays the Q-sample output of channel B by one. See <a href="#">Table 9-23</a> for recommended settings. Only used with complex decimation. Set to 0 with real decimation. 0: Output order is I[n], Q[n] 1: Q-sample is delayed by 1 sample: I[n], Q[n+1], I[n+1], Q[n+2]
2	FS/4 MIX PH B	R/W	0	Inverts the mixer phase for channel B when using FS/4 mixer. 0: Mixer phase is non-inverted 1: Mixer phase is inverted
1-0	0	R/W	0	Must write 0

**Figure 9-22. Register 0x31/32/33/34**

7	6	5	4	3	2	1	0
NCO B [7:0]							
NCO B [15:8]							
NCO B [23:16]							
NCO B [31:24]							
R/W-0	R/W-0	R/W-0	R/W-0	R/W-0	R/W-0	R/W-0	R/W-0

**Table 9-26. Register 0x31/32/33/34 Field Descriptions**

Bit	Field	Type	Reset	Description
7-0	NCO B [31:0]	R/W	0	Sets the 32 bit NCO value for decimation filter channel B. The NCO value is $f_{NCO} \times 2^{32} / F_S$ . In real decimation mode these registers are automatically set to 0.

**Figure 9-23. Register 0x39..0x60**

7	6	5	4	3	2	1	0
OUTPUT BIT MAPPER CHA							
R/W-0	R/W-0	R/W-0	R/W-0	R/W-0	R/W-0	R/W-0	R/W-0

**Table 9-27. Register 0x39..0x60 Field Descriptions**

Bit	Field	Type	Reset	Description
7-0	OUTPUT BIT MAPPER CHA	R/W	0	These registers are used to reorder the output data bus. See the <a href="#">Section 7.3.5.3</a> on how to program it.

**Figure 9-24. Register 0x61..0x88**

7	6	5	4	3	2	1	0
OUTPUT BIT MAPPER CHB							
R/W-0	R/W-0	R/W-0	R/W-0	R/W-0	R/W-0	R/W-0	R/W-0

**Table 9-28. Register 0x61..0x88 Field Descriptions**

Bit	Field	Type	Reset	Description
7-0	OUTPUT BIT MAPPER CHB	R/W	0	These registers are used to reorder the output data bus. See the <a href="#">Section 7.3.5.3</a> on how to program it.

**Figure 9-25. Register 0x8F**

7	6	5	4	3	2	1	0
0	0	0	0	0	0	FORMAT A	0
R/W-0	R/W-0	R/W-0	R/W-0	R/W-0	R/W-0	R/W-0	R/W-0

**Table 9-29. Register 0x8F Field Descriptions**

Bit	Field	Type	Reset	Description
7-2	0	R/W	0	Must write 0
1	FORMAT A	R/W	0	This bit sets the output data format for channel A. Digital bypass register bit (0x24, D2) needs to be enabled as well. 0: 2s complement 1: Offset binary
0	0	R/W	0	Must write 0

**Figure 9-26. Register 0x92**

7	6	5	4	3	2	1	0
0	0	0	0	0	0	FORMAT B	0
R/W-0	R/W-0	R/W-0	R/W-0	R/W-0	R/W-0	R/W-0	R/W-0

**Table 9-30. Register 0x92 Field Descriptions**

Bit	Field	Type	Reset	Description
7-2	0	R/W	0	Must write 0
1	FORMAT B	R/W	0	This bit sets the output data format for channel B. Digital bypass register bit (0x24, D2) needs to be enabled as well. 0: 2s complement 1: Offset binary
0	0	R/W	0	Must write 0

## 10 Device and Documentation Support

### 10.1 Receiving Notification of Documentation Updates

To receive notification of documentation updates, navigate to the device product folder on [ti.com](http://ti.com). Click on *Notifications* to register and receive a weekly digest of any product information that has changed. For change details, review the revision history included in any revised document.

### 10.2 Support Resources

[TI E2E™ support forums](#) are an engineer's go-to source for fast, verified answers and design help — straight from the experts. Search existing answers or ask your own question to get the quick design help you need.

Linked content is provided "AS IS" by the respective contributors. They do not constitute TI specifications and do not necessarily reflect TI's views; see TI's [Terms of Use](#).

### 10.3 Trademarks

PowerPAD™ is a trademark of TI.

TI E2E™ is a trademark of Texas Instruments.

WEBENCH® is a registered trademark of Texas Instruments.

All trademarks are the property of their respective owners.

### 10.4 Electrostatic Discharge Caution



This integrated circuit can be damaged by ESD. Texas Instruments recommends that all integrated circuits be handled with appropriate precautions. Failure to observe proper handling and installation procedures can cause damage.

ESD damage can range from subtle performance degradation to complete device failure. Precision integrated circuits may be more susceptible to damage because very small parametric changes could cause the device not to meet its published specifications.

### 10.5 Glossary

[TI Glossary](#) This glossary lists and explains terms, acronyms, and definitions.

## 11 Revision History

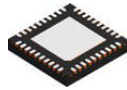
NOTE: Page numbers for previous revisions may differ from page numbers in the current version.

DATE	REVISION	NOTES
February 2025	*	Initial Release

## 12 Mechanical, Packaging, and Orderable Information

The following pages include mechanical, packaging, and orderable information. This information is the most current data available for the designated devices. This data is subject to change without notice and revision of this document. For browser-based versions of this data sheet, refer to the left-hand navigation.

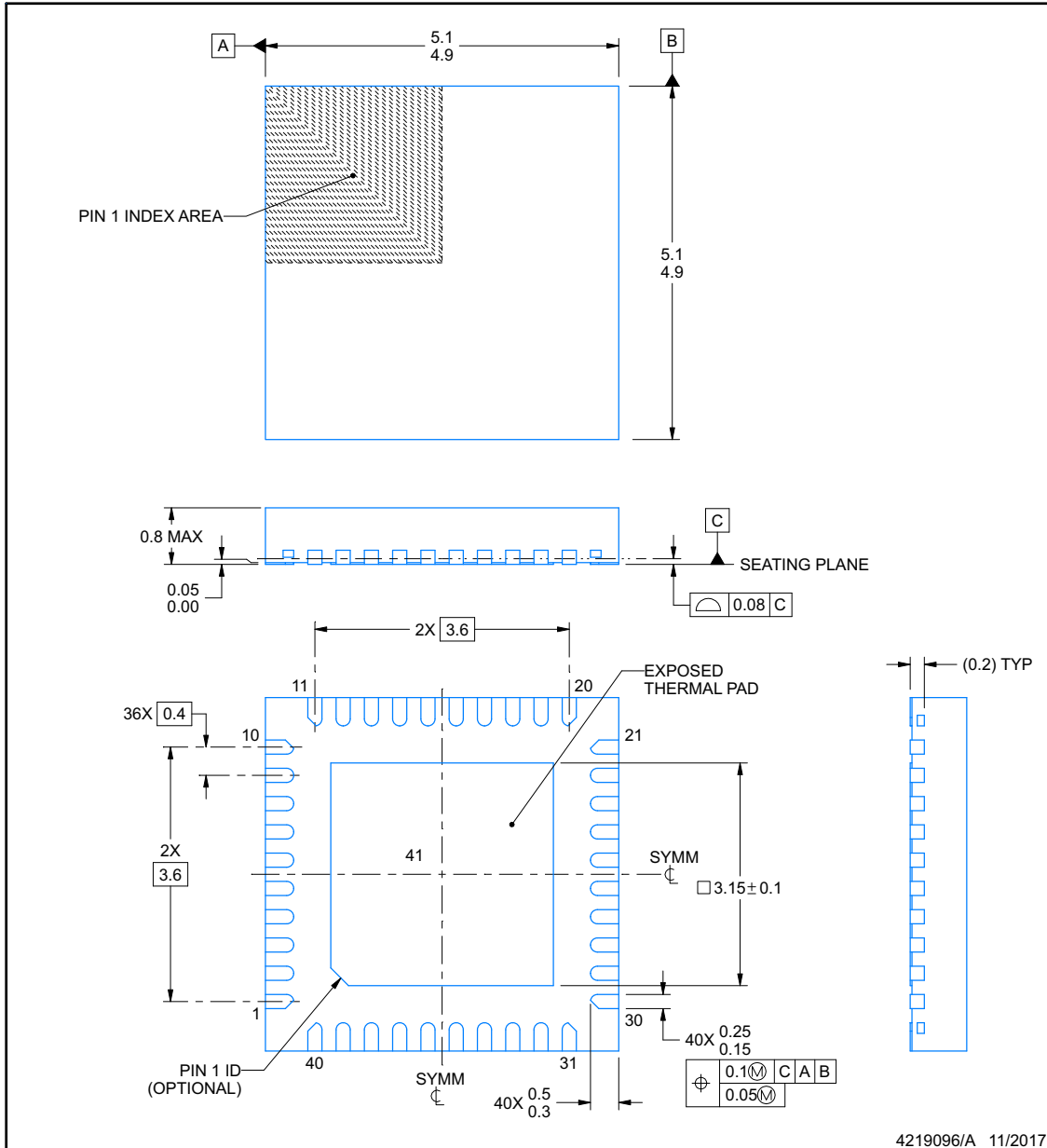
## 12.1 Mechanical Data



**RSB0040E**

**PACKAGE OUTLINE**  
**WQFN - 0.8 mm max height**

PLASTIC QUAD FLATPACK - NO LEAD



**NOTES:**

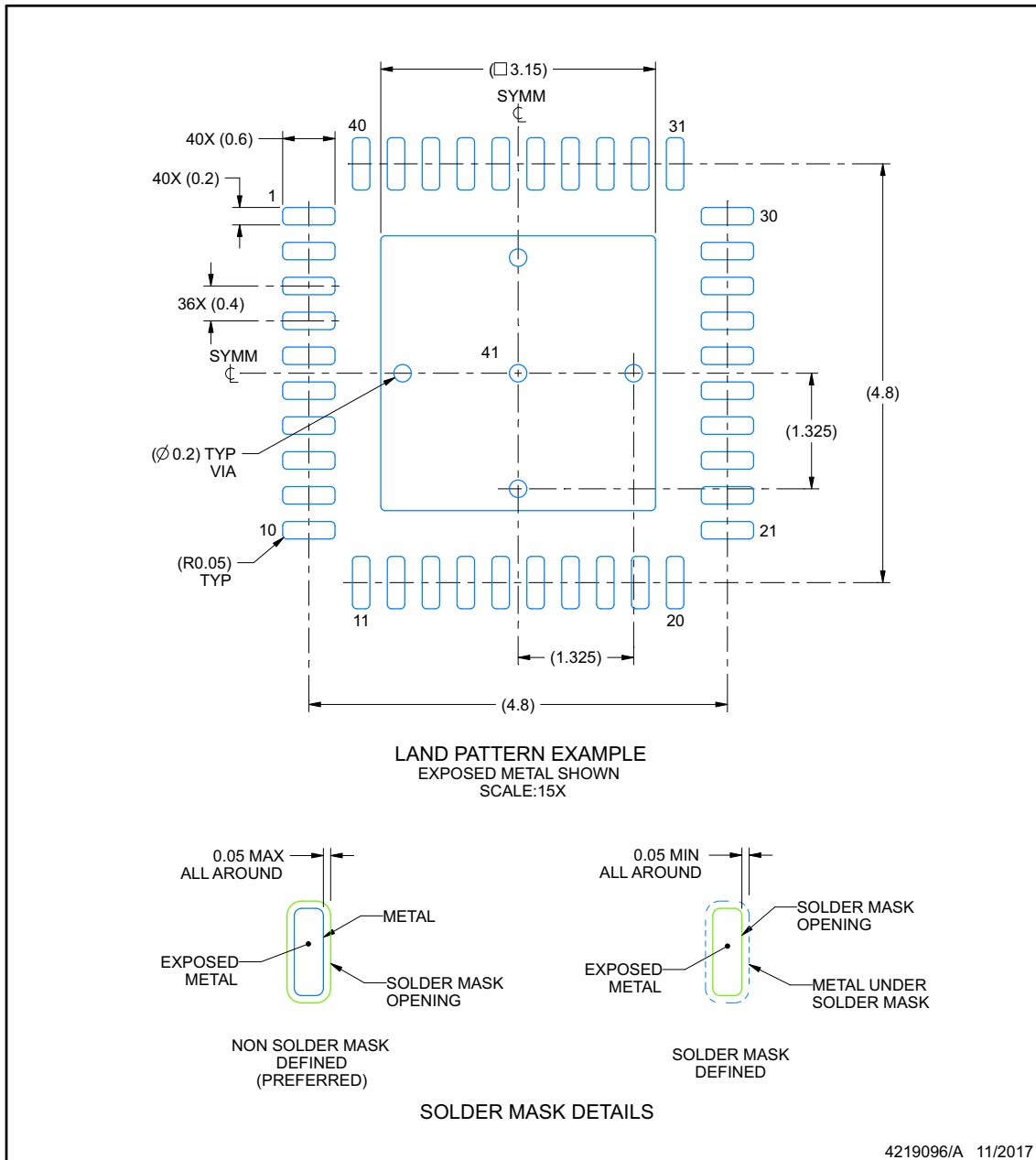
1. All linear dimensions are in millimeters. Any dimensions in parenthesis are for reference only. Dimensioning and tolerancing per ASME Y14.5M.
2. This drawing is subject to change without notice.
3. The package thermal pad must be soldered to the printed circuit board for thermal and mechanical performance.

## EXAMPLE BOARD LAYOUT

**RSB0040E**

**WQFN - 0.8 mm max height**

PLASTIC QUAD FLATPACK - NO LEAD



NOTES: (continued)

- This package is designed to be soldered to a thermal pad on the board. For more information, see Texas Instruments literature number SLUA271 ([www.ti.com/lit/slua271](http://www.ti.com/lit/slua271)).
- Vias are optional depending on application, refer to device data sheet. If any vias are implemented, refer to their locations shown on this view. It is recommended that vias under paste be filled, plugged or tented.

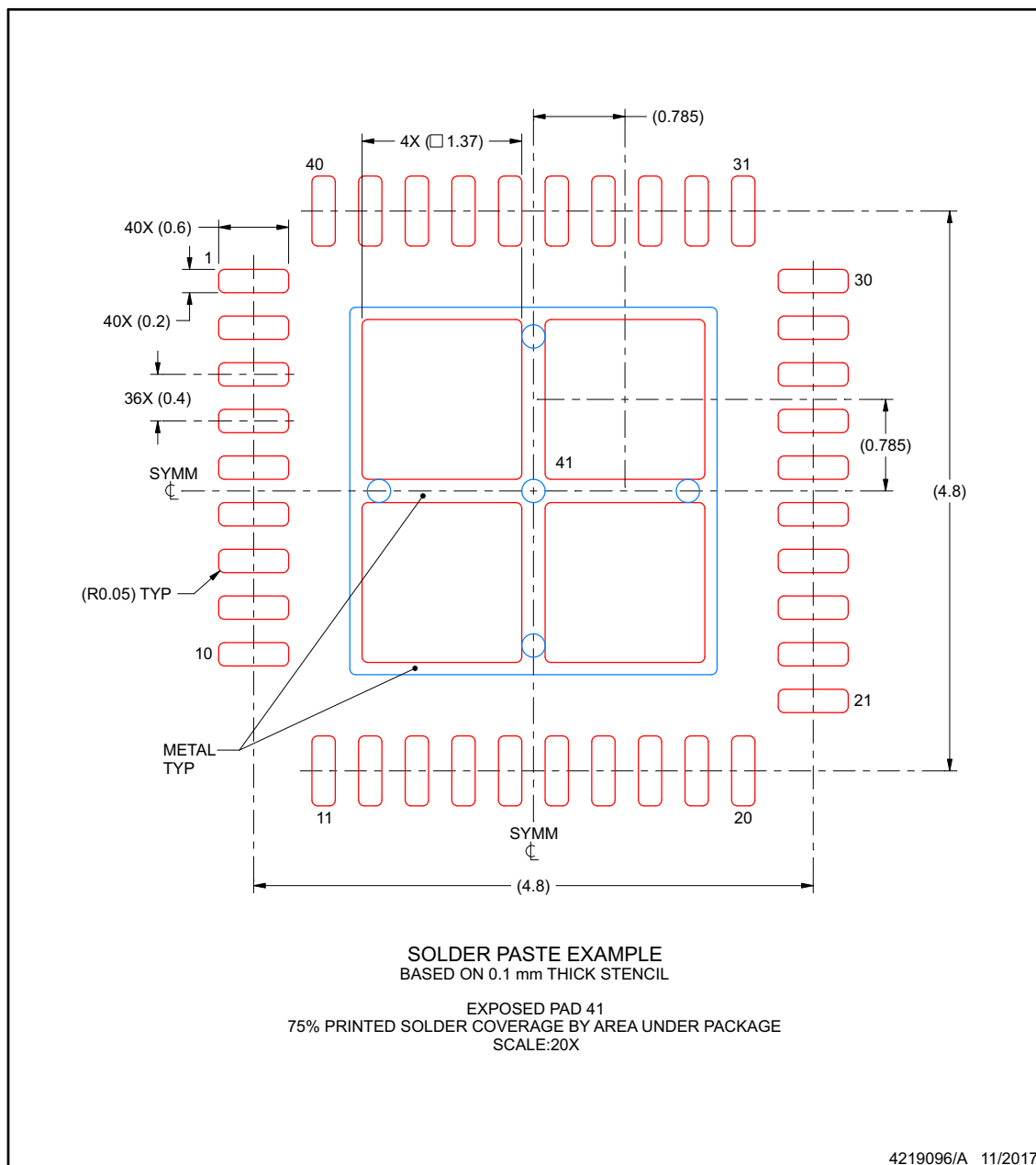
www.ti.com

## EXAMPLE STENCIL DESIGN

**RSB0040E**

**WQFN - 0.8 mm max height**

PLASTIC QUAD FLATPACK - NO LEAD



NOTES: (continued)

6. Laser cutting apertures with trapezoidal walls and rounded corners may offer better paste release. IPC-7525 may have alternate design recommendations.

www.ti.com

**PACKAGING INFORMATION**

Orderable part number	Status (1)	Material type (2)	Package   Pins	Package qty   Carrier	RoHS (3)	Lead finish/ Ball material (4)	MSL rating/ Peak reflow (5)	Op temp (°C)	Part marking (6)
<a href="#">ADC3683RSBTEP</a>	Active	Production	WQFN (RSB)   40	250   SMALL T&R	Yes	NIPDAU	Level-3-260C-168 HR	-55 to 105	ADC3683 EP
<a href="#">ADC3683RSBTSEP</a>	Active	Production	WQFN (RSB)   40	250   SMALL T&R	Yes	NIPDAU	Level-3-260C-168 HR	-55 to 105	ADC3683 SEP
ADC3683RSBTSEP.A	Active	Production	WQFN (RSB)   40	250   SMALL T&R	Yes	NIPDAU	Level-3-260C-168 HR	See ADC3683RSBTSEP	ADC3683 SEP
<a href="#">V62/24602-01XE</a>	Active	Production	WQFN (RSB)   40	250   SMALL T&R	Yes	NIPDAU	Level-3-260C-168 HR	See ADC3683RSBTEP	ADC3683 EP
V62/24602-02XE	Active	Production	WQFN (RSB)   40	250   SMALL T&R	Yes	NIPDAU	Level-3-260C-168 HR	See ADC3683RSBTSEP	ADC3683 SEP

(1) **Status:** For more details on status, see our [product life cycle](#).

(2) **Material type:** When designated, preproduction parts are prototypes/experimental devices, and are not yet approved or released for full production. Testing and final process, including without limitation quality assurance, reliability performance testing, and/or process qualification, may not yet be complete, and this item is subject to further changes or possible discontinuation. If available for ordering, purchases will be subject to an additional waiver at checkout, and are intended for early internal evaluation purposes only. These items are sold without warranties of any kind.

(3) **RoHS values:** Yes, No, RoHS Exempt. See the [TI RoHS Statement](#) for additional information and value definition.

(4) **Lead finish/Ball material:** Parts may have multiple material finish options. Finish options are separated by a vertical ruled line. Lead finish/Ball material values may wrap to two lines if the finish value exceeds the maximum column width.

(5) **MSL rating/Peak reflow:** The moisture sensitivity level ratings and peak solder (reflow) temperatures. In the event that a part has multiple moisture sensitivity ratings, only the lowest level per JEDEC standards is shown. Refer to the shipping label for the actual reflow temperature that will be used to mount the part to the printed circuit board.

(6) **Part marking:** There may be an additional marking, which relates to the logo, the lot trace code information, or the environmental category of the part.

Multiple part markings will be inside parentheses. Only one part marking contained in parentheses and separated by a "~" will appear on a part. If a line is indented then it is a continuation of the previous line and the two combined represent the entire part marking for that device.

**Important Information and Disclaimer:** The information provided on this page represents TI's knowledge and belief as of the date that it is provided. TI bases its knowledge and belief on information provided by third parties, and makes no representation or warranty as to the accuracy of such information. Efforts are underway to better integrate information from third parties. TI has taken and continues to take reasonable steps to provide representative and accurate information but may not have conducted destructive testing or chemical analysis on incoming materials and chemicals. TI and TI suppliers consider certain information to be proprietary, and thus CAS numbers and other limited information may not be available for release.

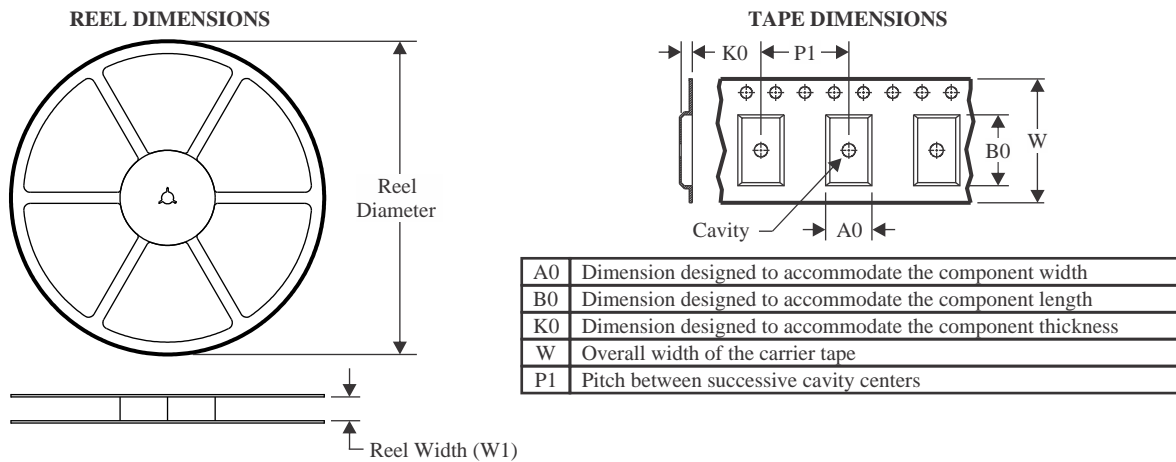
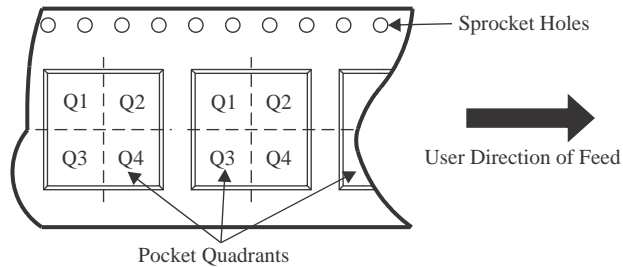
In no event shall TI's liability arising out of such information exceed the total purchase price of the TI part(s) at issue in this document sold by TI to Customer on an annual basis.

**OTHER QUALIFIED VERSIONS OF ADC3683-EP, ADC3683-SEP :**

- Catalog : [ADC3683](#)
- Enhanced Product : [ADC3683-EP](#)
- Space : [ADC3683-SP](#), [ADC3683-SP](#)

NOTE: Qualified Version Definitions:

- Catalog - TI's standard catalog product
- Enhanced Product - Supports Defense, Aerospace and Medical Applications
- Space - Radiation tolerant, ceramic packaging and qualified for use in Space-based application

**TAPE AND REEL INFORMATION**

**QUADRANT ASSIGNMENTS FOR PIN 1 ORIENTATION IN TAPE**


\*All dimensions are nominal

Device	Package Type	Package Drawing	Pins	SPQ	Reel Diameter (mm)	Reel Width W1 (mm)	A0 (mm)	B0 (mm)	K0 (mm)	P1 (mm)	W (mm)	Pin1 Quadrant
ADC3683RSBTEP	WQFN	RSB	40	250	180.0	12.4	5.3	5.3	1.5	8.0	12.0	Q2
ADC3683RSBTSEP	WQFN	RSB	40	250	180.0	12.4	5.3	5.3	1.5	8.0	12.0	Q2

**TAPE AND REEL BOX DIMENSIONS**


\*All dimensions are nominal

Device	Package Type	Package Drawing	Pins	SPQ	Length (mm)	Width (mm)	Height (mm)
ADC3683RSBTEP	WQFN	RSB	40	250	210.0	185.0	35.0
ADC3683RSBTSEP	WQFN	RSB	40	250	210.0	185.0	35.0

## IMPORTANT NOTICE AND DISCLAIMER

TI PROVIDES TECHNICAL AND RELIABILITY DATA (INCLUDING DATASHEETS), DESIGN RESOURCES (INCLUDING REFERENCE DESIGNS), APPLICATION OR OTHER DESIGN ADVICE, WEB TOOLS, SAFETY INFORMATION, AND OTHER RESOURCES "AS IS" AND WITH ALL FAULTS, AND DISCLAIMS ALL WARRANTIES, EXPRESS AND IMPLIED, INCLUDING WITHOUT LIMITATION ANY IMPLIED WARRANTIES OF MERCHANTABILITY, FITNESS FOR A PARTICULAR PURPOSE OR NON-INFRINGEMENT OF THIRD PARTY INTELLECTUAL PROPERTY RIGHTS.

These resources are intended for skilled developers designing with TI products. You are solely responsible for (1) selecting the appropriate TI products for your application, (2) designing, validating and testing your application, and (3) ensuring your application meets applicable standards, and any other safety, security, regulatory or other requirements.

These resources are subject to change without notice. TI grants you permission to use these resources only for development of an application that uses the TI products described in the resource. Other reproduction and display of these resources is prohibited. No license is granted to any other TI intellectual property right or to any third party intellectual property right. TI disclaims responsibility for, and you fully indemnify TI and its representatives against any claims, damages, costs, losses, and liabilities arising out of your use of these resources.

TI's products are provided subject to [TI's Terms of Sale](#), [TI's General Quality Guidelines](#), or other applicable terms available either on [ti.com](http://ti.com) or provided in conjunction with such TI products. TI's provision of these resources does not expand or otherwise alter TI's applicable warranties or warranty disclaimers for TI products. Unless TI explicitly designates a product as custom or customer-specified, TI products are standard, catalog, general purpose devices.

TI objects to and rejects any additional or different terms you may propose.

Copyright © 2026, Texas Instruments Incorporated

Last updated 10/2025