

TAPE AND REEL INFORMATION

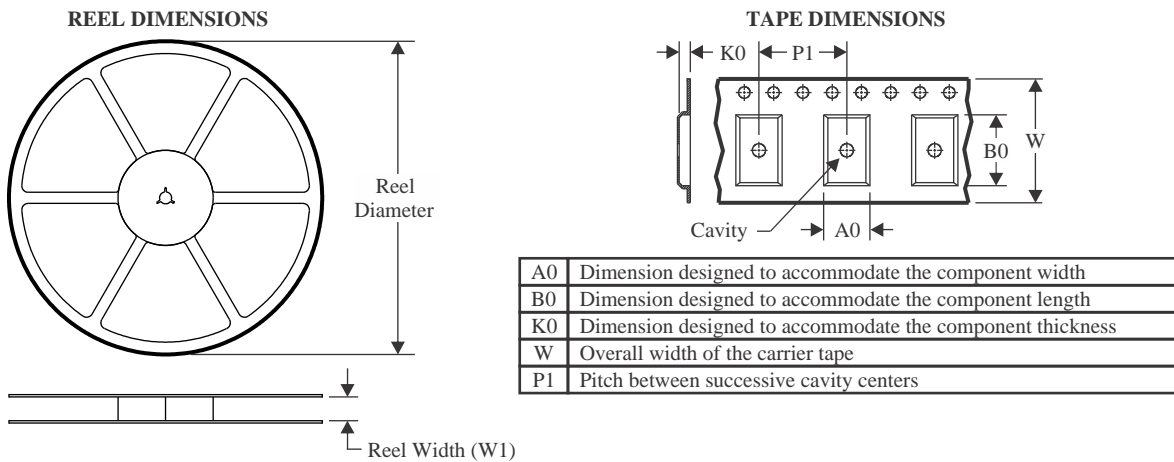

QUADRANT ASSIGNMENTS FOR PIN 1 ORIENTATION IN TAPE



*All dimensions are nominal

Device	Package Type	Package Drawing	Pins	SPQ	Reel Diameter (mm)	Reel Width W1 (mm)	A0 (mm)	B0 (mm)	K0 (mm)	P1 (mm)	W (mm)	Pin1 Quadrant
TLV9020QDBVRQ1	SOT-23	DBV	5	3000	180.0	8.4	3.2	3.2	1.4	4.0	8.0	Q3
TLV9020QDCKRQ1	SC70	DCK	5	3000	178.0	9.0	2.4	2.5	1.2	4.0	8.0	Q3
TLV9021QDBVRQ1	SOT-23	DBV	5	3000	180.0	8.4	3.2	3.2	1.4	4.0	8.0	Q3
TLV9021QDCKRQ1	SC70	DCK	5	3000	178.0	9.0	2.4	2.5	1.2	4.0	8.0	Q3
TLV9022QDDFRQ1	SOT-23-THIN	DDF	8	3000	180.0	8.4	3.2	3.2	1.4	4.0	8.0	Q3
TLV9022QDGRQ1	VSSOP	DGK	8	2500	330.0	12.4	5.3	3.4	1.4	8.0	12.0	Q1
TLV9022QDRQ1	SOIC	D	8	2500	330.0	12.4	6.4	5.2	2.1	8.0	12.0	Q1
TLV9022QPWRQ1	TSSOP	PW	8	2000	330.0	12.4	7.0	3.6	1.6	8.0	12.0	Q1
TLV9024QDRQ1	SOIC	D	14	2500	330.0	16.4	6.5	9.0	2.1	8.0	16.0	Q1
TLV9024QDYRQ1	SOT-23-THIN	DYY	14	3000	330.0	12.4	4.8	3.6	1.6	8.0	12.0	Q3
TLV9024QPWRQ1	TSSOP	PW	14	2000	330.0	12.4	6.9	5.6	1.6	8.0	12.0	Q1
TLV9030QDBVRQ1	SOT-23	DBV	5	3000	180.0	8.4	3.2	3.2	1.4	4.0	8.0	Q3
TLV9030QDCKRQ1	SC70	DCK	5	3000	178.0	9.0	2.4	2.5	1.2	4.0	8.0	Q3
TLV9031QDBVRQ1	SOT-23	DBV	5	3000	180.0	8.4	3.2	3.2	1.4	4.0	8.0	Q3
TLV9031QDCKRQ1	SC70	DCK	5	3000	178.0	9.0	2.4	2.5	1.2	4.0	8.0	Q3

Device	Package Type	Package Drawing	Pins	SPQ	Reel Diameter (mm)	Reel Width W1 (mm)	A0 (mm)	B0 (mm)	K0 (mm)	P1 (mm)	W (mm)	Pin1 Quadrant
TLV9032QDDFRQ1	SOT-23-THIN	DDF	8	3000	180.0	8.4	3.2	3.2	1.4	4.0	8.0	Q3
TLV9032QDGKRQ1	VSSOP	DGK	8	2500	330.0	12.4	5.3	3.4	1.4	8.0	12.0	Q1
TLV9032QDRQ1	SOIC	D	8	2500	330.0	12.4	6.4	5.2	2.1	8.0	12.0	Q1
TLV9034QDRQ1	SOIC	D	14	2500	330.0	16.4	6.5	9.0	2.1	8.0	16.0	Q1
TLV9034QDYRQ1	SOT-23-THIN	DYY	14	3000	330.0	12.4	4.8	3.6	1.6	8.0	12.0	Q3
TLV9034QPWRQ1	TSSOP	PW	14	2000	330.0	12.4	6.9	5.6	1.6	8.0	12.0	Q1

TAPE AND REEL BOX DIMENSIONS

*All dimensions are nominal

Device	Package Type	Package Drawing	Pins	SPQ	Length (mm)	Width (mm)	Height (mm)
TLV9020QDBVRQ1	SOT-23	DBV	5	3000	210.0	185.0	35.0
TLV9020QDCKRQ1	SC70	DCK	5	3000	190.0	190.0	30.0
TLV9021QDBVRQ1	SOT-23	DBV	5	3000	210.0	185.0	35.0
TLV9021QDCKRQ1	SC70	DCK	5	3000	190.0	190.0	30.0
TLV9022QDDFRQ1	SOT-23-THIN	DDF	8	3000	210.0	185.0	35.0
TLV9022QDGKRQ1	VSSOP	DGK	8	2500	366.0	364.0	50.0
TLV9022QDRQ1	SOIC	D	8	2500	356.0	356.0	35.0
TLV9022QPWRQ1	TSSOP	PW	8	2000	356.0	356.0	35.0
TLV9024QDRQ1	SOIC	D	14	2500	356.0	356.0	35.0
TLV9024QDYRQ1	SOT-23-THIN	DYY	14	3000	336.6	336.6	31.8
TLV9024QPWRQ1	TSSOP	PW	14	2000	356.0	356.0	35.0
TLV9030QDBVRQ1	SOT-23	DBV	5	3000	210.0	185.0	35.0
TLV9030QDCKRQ1	SC70	DCK	5	3000	190.0	190.0	30.0
TLV9031QDBVRQ1	SOT-23	DBV	5	3000	210.0	185.0	35.0
TLV9031QDCKRQ1	SC70	DCK	5	3000	190.0	190.0	30.0
TLV9032QDDFRQ1	SOT-23-THIN	DDF	8	3000	210.0	185.0	35.0
TLV9032QDGKRQ1	VSSOP	DGK	8	2500	366.0	364.0	50.0
TLV9032QDRQ1	SOIC	D	8	2500	356.0	356.0	35.0

Device	Package Type	Package Drawing	Pins	SPQ	Length (mm)	Width (mm)	Height (mm)
TLV9034QDRQ1	SOIC	D	14	2500	356.0	356.0	35.0
TLV9034QDYRQ1	SOT-23-THIN	DYY	14	3000	336.6	336.6	31.8
TLV9034QPWRQ1	TSSOP	PW	14	2000	356.0	356.0	35.0