

EVM User's Guide: TPS62A212EVM-059

TPS62A212-Q1 降压转换器评估模块



说明

TPS62A212EVM-059 旨在帮助用户轻松评估和测试用于汽车应用的 TPS62A2xx-Q1 降压转换器的运行情况和功能。该 EVM 可在输出电流高达 12A 的情况下，将 2.7V 至 6.0V 的输入电压转换为 1.2V 的稳压输出电压，精度为 0.8%。

开始使用

1. 订购 TPS62A212EVM-059。
2. 请参阅 [TPS62A2xx-Q1 2.7V 至 6V 输入，8A、10A 和 12A 汽车级快速瞬态同步降压转换器数据表](#)。
3. 使用以下平台协助选择元件：
 - a. 模型：WEBENCH® 电路设计与选择仿真服务、SIMPLIS、Gerber 文件和计算器表

特性

- 输入电压范围：2.7V 至 6.0V
- 电阻可选启动输出电压范围：0.4V 至 3.3V
- 电阻可选开关频率：1.5MHz、2.25MHz、2.5MHz 或 4MHz
- 电阻可选补偿设置
- 可实现轻负载效率的省电模式

应用

- ADAS 域控制器
- 数字驾驶室处理单元
- 驾驶员监控
- 前置摄像头

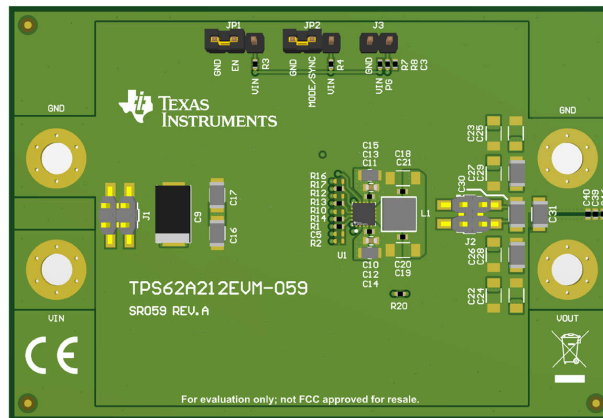

TPS62A212EVM-059 (顶视图)

1 评估模块概述

1.1 简介

本用户指南介绍了 TI 的 TPS62A2xx-Q1 器件评估模块 (EVM) 的特性、运行和使用情况。TPS62A212EVM-059 可用于评估 TPS62A208-Q1、

TPS62A210-Q1 和 TPS62A212-Q1 器件系列。EVM 可将 2.7V 至 6.0V 的输入电压转换为 1.2V 稳压输出电压，且开关频率设置为 2.5MHz。TPS62A212EVM-059 的输出电流可高达 12A。本用户指南包括硬件设置说明、印刷电路板 (PCB) 布局、原理图和物料清单 (BOM)。

1.2 套件内容

表 1-1. TPS62A212EVM-059 套件内容

条目	说明	数量
TPS62A212EVM-059	PCB	1

1.3 规格

表 1-2 提供了 TPS62A212EVM-059 性能规格的汇总。

表 1-2. 性能规格汇总

规格		测试条件	最小值	典型值	最大值	单位
输入电压			2.7		6.0	V
输出电压设定点				1.2		V
输出电流	TPS62A212EVM-059		0		12.0	A

1.4 器件信息

TPS62A2xx-Q1 是实现 PLL 恒定导通时间控制方案的一款同步降压直流/直流转换器，可支持固定频率运行的快速瞬态。TPS62A208-Q1、

TPS62A210-Q1 和 TPS62A212-Q1 是一系列引脚对引脚 8A、10A 和 12A 同步降压直流/直流转换器，采用 WQFN 3mm × 3mm 封装。该转换器具有 2.7V 至 6.0V 的输入电压范围，电阻可选启动输出电压范围为 0.4V 至 3.3V。低电阻开关可在高输出电流和高环境温度下实现高效运行。器件的开关频率可在 CONF 引脚处通过 R2D 进行外部调节（范围 1.5MHz 到 4MHz），也可在 MODE/SYNC 引脚处与相同频率范围内的外部时钟同步。在自动模式下，TPS62A2xx-Q1 会在轻负载情况下自动进入省电模式，从而在整个负载范围内维持高效率。有关更多详细信息，请参阅 [TPS62A2xx-Q1 2.7V 至 6V 输入，8A、10A 和 12A 汽车级快速瞬态同步降压转换器数据表](#)。

2 硬件

2.1 设置

本节介绍了如何正确使用 TPS62A212EVM-059。

2.1.1 连接器说明

MH1 - VIN	从 EVM 输入电源的正输入电压连接。
J1.1 , J1.3 - VINsense	输入电压检测连接，测量此处的输入电压。
J1.2 , J1.4 - GNDsense	
MH2 - GND	从 EVM 输入电源输入返回连接。
MH3 - VOUT	正输出电压连接。
J2.3 , J2.4 - VOUTsense	输出电压检测连接，测量此处的输出电压。
J2.1 , J2.2 - GNDsense	
MH4 - GND	输出返回连接。
JP1 - EN	EN 引脚跳线。使提供的跳线跨接 ON 和 EN 以开启 IC。使跳线跨接 OFF 和 EN 以关闭 IC。
JP2	MODE/SYNC 引脚跳线。使用提供的跳线跨接 MODE/SYNC 和 GND，从而强制器件在所有负载电流下均以固定频率 PWM 模式运行。使用跳线跨接 VIN 和 MODE/SYNC，以便启用省电模式。使该引脚悬空，然后将时钟信号连接到以 GND 为参考的 MODE/SYNC，以使开关频率与时钟信号同步。
J3 - PG	PG 输出位于该接头的引脚 1 上，在引脚 2 上 轻松接地。

2.1.2 硬件设置

要操作 EVM，请按照 节 2.1.1 所述将 JMP1 处的跳线设置到所需位置。将输入电源连接到 VIN 和 GND 之间的 MH1 和 MH2，并将负载连接到 VOUT 和 GND 之间的 MH3 和 MH4。

2.2 注意



小心

表面高温。
接触会导致烫伤。
请勿触摸！

3 实现结果

3.1 TPS62A212EVM-059 测试结果

TPS62A212EVM-059 用于获取 TPS62A2xx-Q1 数据表中的典型特性数据。请参阅 [TPS62A2xx-Q1 2.7V 至 6V 输入, 8A、10A 和 12A 汽车级快速瞬态同步降压转换器 数据表](#), 了解此 EVM 的性能。

3.2 更改

此 EVM 的印刷电路板 (PCB) 旨在适应此集成电路 (IC) 的不同输出电流版本。在 EVM 上, 可以添加其他输入和输出电容器, 并且可以更改默认输出电压、开关频率和补偿设置。

3.2.1 输入和输出电容器

此 EVM 为额外的输入电容器和额外的输出电容器提供了空间。这些电容器不是正常运行所必需的, 但可用于减少输入和输出电压纹波并提高负载瞬态响应。为确保正常运行, 总输出电容必须保持在建议的范围内, 请参阅 [TPS62A2xx-Q1 2.7V 至 6V 输入, 8A、10A 和 12A 汽车级快速瞬态同步降压转换器 数据表](#)。

3.2.2 输出电压设置

U1 的输出电压默认设置为 1.2V。通过为 VSET 引脚电阻器 R7 和 R8 选择适当的值可以设置其他默认电压, 以在 64 个不同的电压设定值之间切换。有关相应的 Vout 设置, 请参阅 [TPS62A2xx-Q1 2.7V 至 6V 输入, 8A、10A 和 12A 汽车级快速瞬态同步降压转换器 数据表](#)。

3.2.3 补偿

Comp 引脚连接到电阻器 R10 和 R11, 这两个电阻器用于更改控制环路的补偿设置。EVM 的 COMP 设置为 3.75, 可以更改 R10 和 R11 以调节为 16 种不同的内部补偿设置。有关更多详细信息, 请参阅 [TPS62A2xx-Q1 2.7V 至 6V 输入, 8A、10A 和 12A 汽车级快速瞬态同步降压转换器 数据表](#)。

3.2.4 开关频率

CONF 引脚连接到电阻器 R12 和 R13 以调整开关频率。EVM 的默认设置为 2.5MHz, 可以更改 R12 和 R13 以将开关频率调节为 1.5MHz、2.25MHz、2.5MHz 和 4MHz。有关更多详细信息, 请参阅 [TPS62A2xx-Q1 2.7V 至 6V 输入, 8A、10A 和 12A 汽车级快速瞬态同步降压转换器 数据表](#)。

4 硬件设计文件

4.1 原理图

图 4-1 展示了 TPS62A212EVM-059 原理图。



图 4-1. TPS62A212EVM-059 原理图

4.2 PCB 布局

本节介绍了 TPS62A212EVM-059 电路板布局布线。

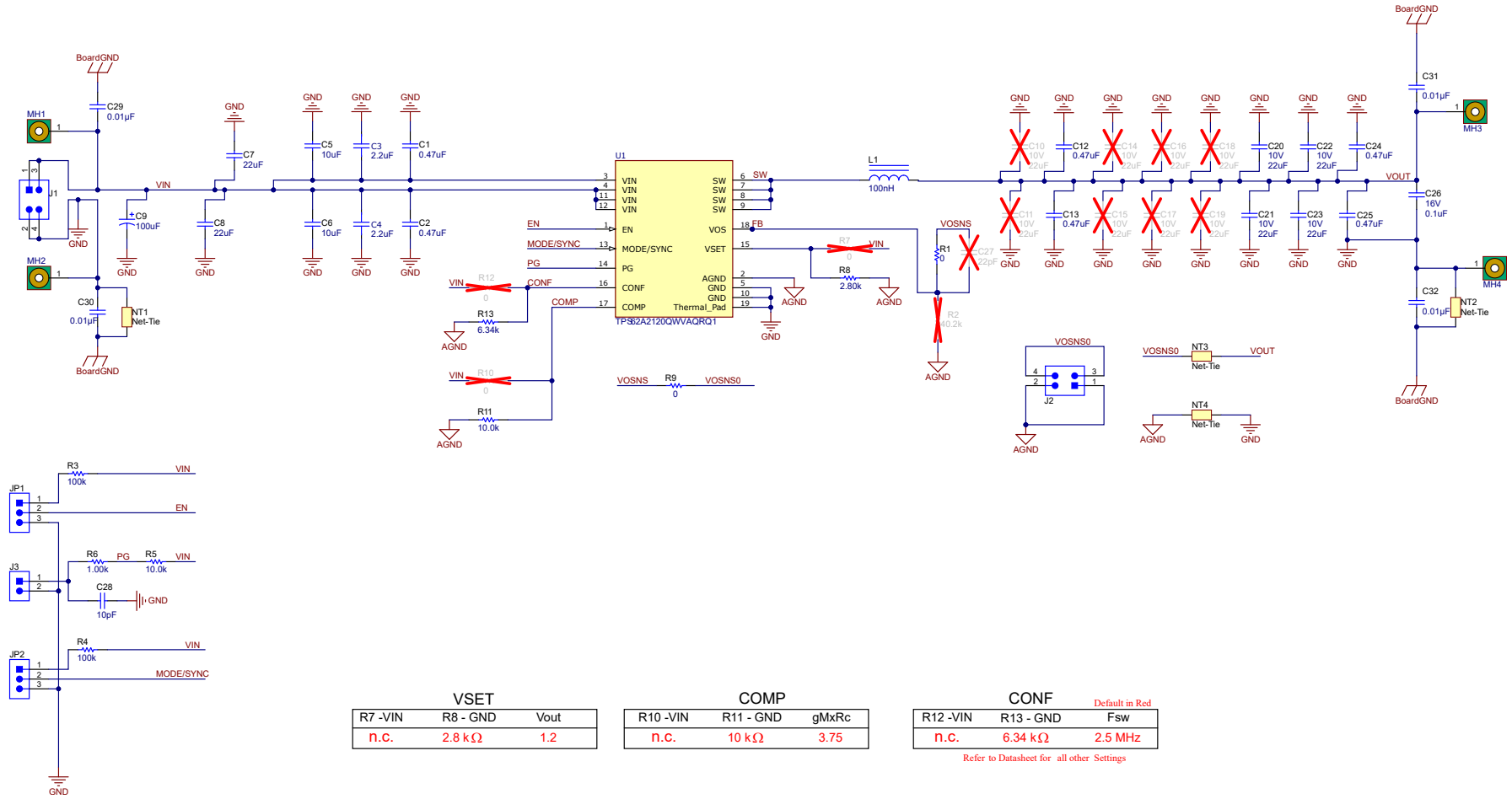

图 4-2. 顶部丝网



图 4-3. 顶层

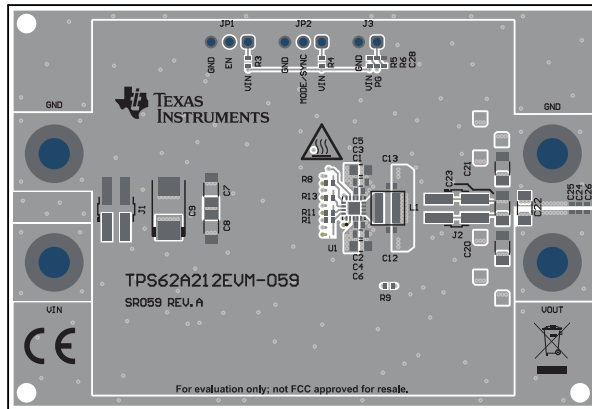

图 4-4. 信号层 1

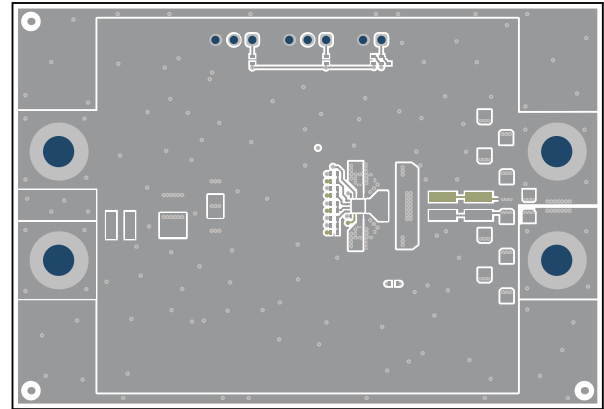

图 4-5. 信号层 2

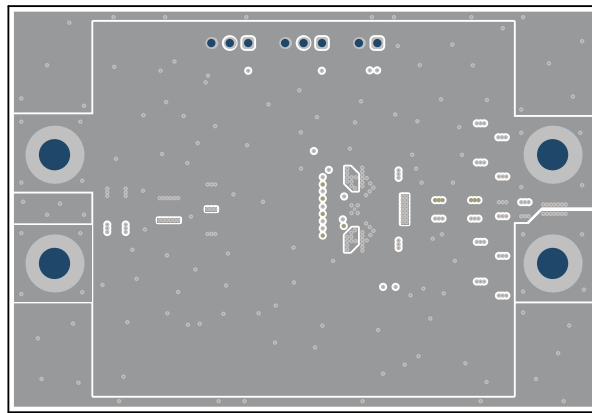

图 4-6. 信号层 3

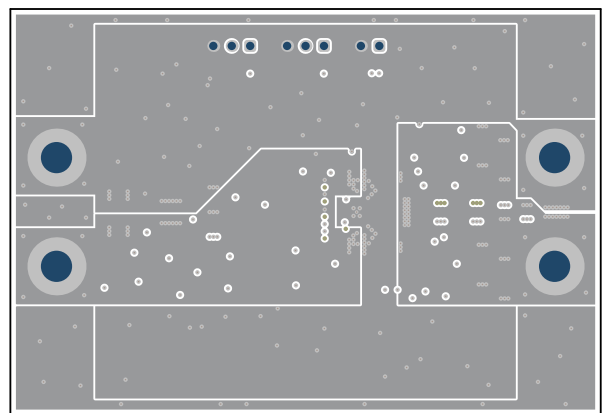

图 4-7. 信号层 4

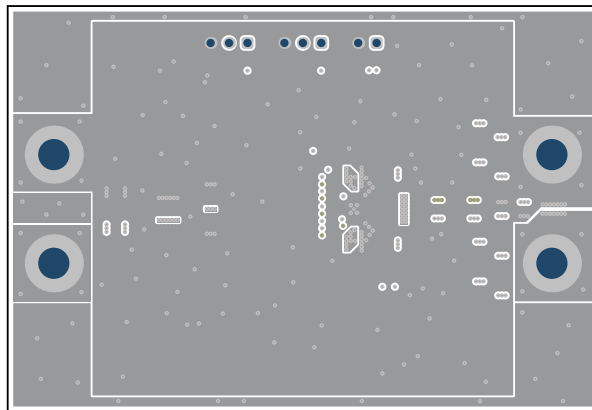

图 4-8. 信号层 5

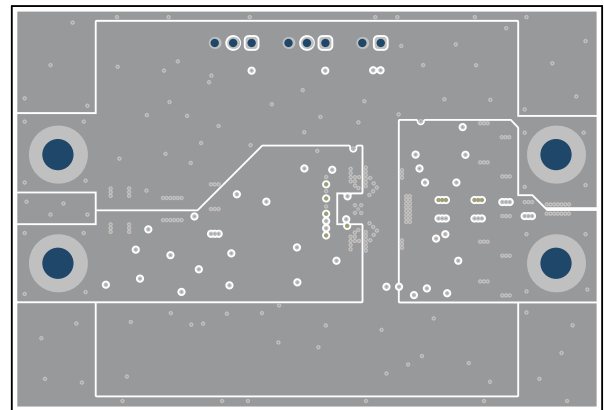

图 4-9. 信号层 6

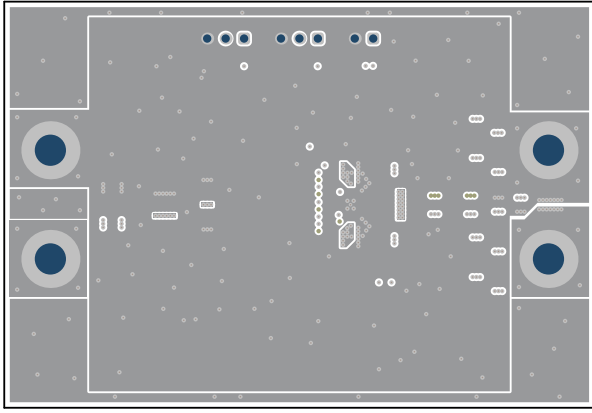

图 4-10. 底层

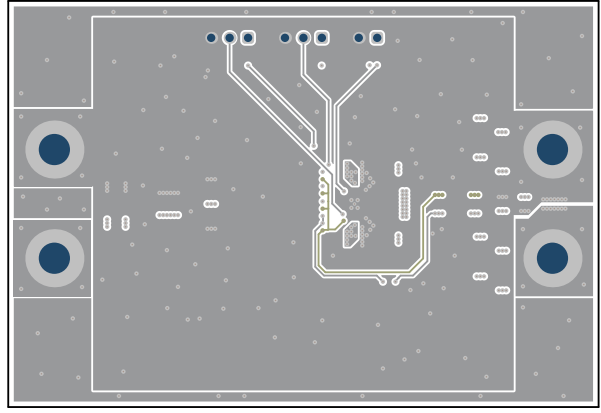

图 4-11. 底视图

4.3 物料清单 (BOM)

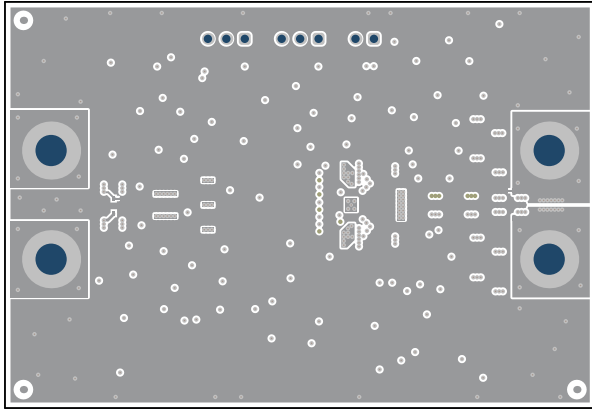
下表显示 TPS62A212EVM-059 的物料清单。

表 4-1. 物料清单

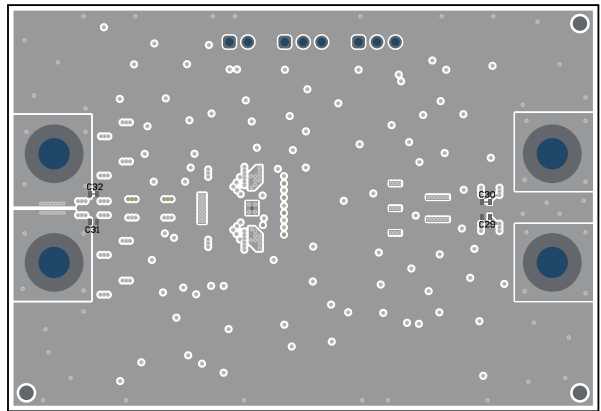
条目	位号	数量	值	器件型号	制造商	说明	封装参考
1	!PCB	1		SR059	不限	印刷电路板	
2	C1、C2、C12、C13、C24、C25	6	0.47uF	GCM155C71A474KE36D	MuRata	电容, 陶瓷, 0.47uF, 10V, +/-10%, X7S, 0402	0402
3	C3、C4	2	2.2μF	CGA3E3X7S1A225K080AB	TDK	电容, 陶瓷, 2.2uF, 10V, X7S, 10%, 焊盘 SMD, 0603, +125°C, 汽车 T/R	0603
4	C5、C6	2	10uF	GCM21BR71A106KE22L	MuRata	电容, 陶瓷, 10uF, 10V, +/-10%, X7R, 0805	0805
5	C7、C8、C20、C21、C22、C23	6	22uF	GCM31CR71A226KE02L	MuRata	电容, 陶瓷, 22uF, 10V, +/- 10%, X7R, AEC-Q200 1 级, 1206	1206
6	C9	1	100uF	20TQC100MYF	Panasonic	电容, 钽聚合物, 100uF, 20V, +/- 20%, 0.055 Ω, 7.3x4.3mm SMD	7.3x4.3mm
7	C26	1	0.1uF	GRM155R61C104KA88D	MuRata	电容, 陶瓷, 0.1uF, 16V, +/-10%, X5R, 0402	0402
8	C28	1	10pF	GCM1555C1H100JA16D	MuRata	电容, 陶瓷, 10pF, 50V, +/-5%, C0G/NP0, AEC-Q200 1 级, 0402	0402
9	C29、C30、C31、C32	4	0.01uF	CGA2B3X8R1H103K050BB	TDK	电容, 陶瓷, 0.01μF, 50V, +/-10%, X8R, AEC-Q200 0 级, 0402	0402
10	FID4、FID5、FID6	3		不适用	不适用	基准标记。没有需要购买或安装的元件。	不适用
11	J1、J2	2		TSM-102-01L-DV	Samtec	接头, 2.54mm, 2x2, 金, SMT	接头, 2.54mm, 2x2, SMT
12	J3	1		61300211121	Würth Elektronik	接头, 2.54mm, 2x1, 金, TH	接头, 2.54mm, 2x1, TH
13	JP1、JP2	2		61300311121	Würth Elektronik	接头, 2.54mm, 3x1, 金, TH	接头, 2.54mm, 3x1, TH
14	L1	1	100nH	XEL4030-101MEB	Coilcraft	电感器, 屏蔽, 100nH, 20.4A, 0.0018ohm, SMD	4x4mm
15	R1、R9	2	0	CRCW04020000Z0ED	Vishay-Dale	电阻, 0, 5%, 0.063W, AEC-Q200 0 级, 0402	0402
16	R3、R4	2	100k	CRCW0402100KFKED	Vishay-Dale	电阻, 100k, 1%, 0.063W, AEC-Q200 0 级, 0402	0402
17	R5、R11	2	10.0k	CRCW040210K0FKED	Vishay-Dale	电阻, 10.0k, 1%, 0.063W, AEC-Q200 0 级, 0402	0402
18	R6	1	1.00k	CRCW04021K00FKED	Vishay-Dale	电阻, 1.00k, 1%, 0.063W, AEC-Q200 0 级, 0402	0402

表 4-1. 物料清单 (续)

条目	位号	数量	值	器件型号	制造商	说明	封装参考
19	R8	1	2.80k	CRCW04022K80FKED	Vishay-Dale	电阻, 2.80k, 1%, 0.063W, AEC-Q200 0级, 0402	0402
20	R13	1	6.34k	CRCW04026K34FKED	Vishay-Dale	电阻, 6.34k, 1%, 0.063W, AEC-Q200 0级, 0402	0402
21	SH-J1、SH-J2	2	1x2	SNT-100-BK-G	Samtec	分流器, 100mil, 镀金, 黑色	分流器
22	U1	1		TPS62A2120QWVAQRQ1	德州仪器 (TI)	2.7V 至 6V 输入, 12A 汽车级快速瞬态同步降压转换器	WQFN-FCRL18
23	C10、C11、C14、C15、C16、C17、C18、C19	0	22uF	GCM31CR71A226KE02L	MuRata	电容, 陶瓷, 22uF, 10V, +/- 10%, X7R, AEC-Q200 1级, 1206	1206
24	C27	0	22pF	GCM1555C1H220JA16D	MuRata	电容, 陶瓷, 22pF, 50V, +/-5%, C0G/NP0, AEC-Q200 1级, 0402	0402
25	FID1、FID2、FID3	0		不适用	不适用	基准标记。没有需要购买或安装的元件。	不适用
26	R2	0	40.2k	CRCW040240K2FKED	Vishay-Dale	电阻, 40.2k, 1%, 0.063W, AEC-Q200 0级, 0402	0402
27	R7、R10、R12	0	0	CRCW04020000Z0ED	Vishay-Dale	电阻, 0, 5%, 0.063W, AEC-Q200 0级, 0402	0402

5 其他信息

5.1 商标

WEBENCH® is a registered trademark of Texas Instruments.
所有商标均为其各自所有者的财产。

STANDARD TERMS FOR EVALUATION MODULES

1. *Delivery:* TI delivers TI evaluation boards, kits, or modules, including any accompanying demonstration software, components, and/or documentation which may be provided together or separately (collectively, an "EVM" or "EVMs") to the User ("User") in accordance with the terms set forth herein. User's acceptance of the EVM is expressly subject to the following terms.
 - 1.1 EVMs are intended solely for product or software developers for use in a research and development setting to facilitate feasibility evaluation, experimentation, or scientific analysis of TI semiconductors products. EVMs have no direct function and are not finished products. EVMs shall not be directly or indirectly assembled as a part or subassembly in any finished product. For clarification, any software or software tools provided with the EVM ("Software") shall not be subject to the terms and conditions set forth herein but rather shall be subject to the applicable terms that accompany such Software
 - 1.2 EVMs are not intended for consumer or household use. EVMs may not be sold, sublicensed, leased, rented, loaned, assigned, or otherwise distributed for commercial purposes by Users, in whole or in part, or used in any finished product or production system.
2. *Limited Warranty and Related Remedies/Disclaimers:*
 - 2.1 These terms do not apply to Software. The warranty, if any, for Software is covered in the applicable Software License Agreement.
 - 2.2 TI warrants that the TI EVM will conform to TI's published specifications for ninety (90) days after the date TI delivers such EVM to User. Notwithstanding the foregoing, TI shall not be liable for a nonconforming EVM if (a) the nonconformity was caused by neglect, misuse or mistreatment by an entity other than TI, including improper installation or testing, or for any EVMs that have been altered or modified in any way by an entity other than TI, (b) the nonconformity resulted from User's design, specifications or instructions for such EVMs or improper system design, or (c) User has not paid on time. Testing and other quality control techniques are used to the extent TI deems necessary. TI does not test all parameters of each EVM. User's claims against TI under this Section 2 are void if User fails to notify TI of any apparent defects in the EVMs within ten (10) business days after delivery, or of any hidden defects with ten (10) business days after the defect has been detected.
 - 2.3 TI's sole liability shall be at its option to repair or replace EVMs that fail to conform to the warranty set forth above, or credit User's account for such EVM. TI's liability under this warranty shall be limited to EVMs that are returned during the warranty period to the address designated by TI and that are determined by TI not to conform to such warranty. If TI elects to repair or replace such EVM, TI shall have a reasonable time to repair such EVM or provide replacements. Repaired EVMs shall be warranted for the remainder of the original warranty period. Replaced EVMs shall be warranted for a new full ninety (90) day warranty period.

WARNING

Evaluation Kits are intended solely for use by technically qualified, professional electronics experts who are familiar with the dangers and application risks associated with handling electrical mechanical components, systems, and subsystems.

User shall operate the Evaluation Kit within TI's recommended guidelines and any applicable legal or environmental requirements as well as reasonable and customary safeguards. Failure to set up and/or operate the Evaluation Kit within TI's recommended guidelines may result in personal injury or death or property damage. Proper set up entails following TI's instructions for electrical ratings of interface circuits such as input, output and electrical loads.

NOTE:

EXPOSURE TO ELECTROSTATIC DISCHARGE (ESD) MAY CAUSE DEGRADATION OR FAILURE OF THE EVALUATION KIT; TI RECOMMENDS STORAGE OF THE EVALUATION KIT IN A PROTECTIVE ESD BAG.

3 Regulatory Notices:

3.1 United States

3.1.1 Notice applicable to EVMs not FCC-Approved:

FCC NOTICE: This kit is designed to allow product developers to evaluate electronic components, circuitry, or software associated with the kit to determine whether to incorporate such items in a finished product and software developers to write software applications for use with the end product. This kit is not a finished product and when assembled may not be resold or otherwise marketed unless all required FCC equipment authorizations are first obtained. Operation is subject to the condition that this product not cause harmful interference to licensed radio stations and that this product accept harmful interference. Unless the assembled kit is designed to operate under part 15, part 18 or part 95 of this chapter, the operator of the kit must operate under the authority of an FCC license holder or must secure an experimental authorization under part 5 of this chapter.

3.1.2 For EVMs annotated as FCC – FEDERAL COMMUNICATIONS COMMISSION Part 15 Compliant:

CAUTION

This device complies with part 15 of the FCC Rules. Operation is subject to the following two conditions: (1) This device may not cause harmful interference, and (2) this device must accept any interference received, including interference that may cause undesired operation.

Changes or modifications not expressly approved by the party responsible for compliance could void the user's authority to operate the equipment.

FCC Interference Statement for Class A EVM devices

NOTE: This equipment has been tested and found to comply with the limits for a Class A digital device, pursuant to part 15 of the FCC Rules. These limits are designed to provide reasonable protection against harmful interference when the equipment is operated in a commercial environment. This equipment generates, uses, and can radiate radio frequency energy and, if not installed and used in accordance with the instruction manual, may cause harmful interference to radio communications. Operation of this equipment in a residential area is likely to cause harmful interference in which case the user will be required to correct the interference at his own expense.

FCC Interference Statement for Class B EVM devices

NOTE: This equipment has been tested and found to comply with the limits for a Class B digital device, pursuant to part 15 of the FCC Rules. These limits are designed to provide reasonable protection against harmful interference in a residential installation. This equipment generates, uses and can radiate radio frequency energy and, if not installed and used in accordance with the instructions, may cause harmful interference to radio communications. However, there is no guarantee that interference will not occur in a particular installation. If this equipment does cause harmful interference to radio or television reception, which can be determined by turning the equipment off and on, the user is encouraged to try to correct the interference by one or more of the following measures:

- Reorient or relocate the receiving antenna.
- Increase the separation between the equipment and receiver.
- Connect the equipment into an outlet on a circuit different from that to which the receiver is connected.
- Consult the dealer or an experienced radio/TV technician for help.

3.2 Canada

3.2.1 For EVMs issued with an Industry Canada Certificate of Conformance to RSS-210 or RSS-247

Concerning EVMs Including Radio Transmitters:

This device complies with Industry Canada license-exempt RSSs. Operation is subject to the following two conditions:

(1) this device may not cause interference, and (2) this device must accept any interference, including interference that may cause undesired operation of the device.

Concernant les EVMs avec appareils radio:

Le présent appareil est conforme aux CNR d'Industrie Canada applicables aux appareils radio exempts de licence. L'exploitation est autorisée aux deux conditions suivantes: (1) l'appareil ne doit pas produire de brouillage, et (2) l'utilisateur de l'appareil doit accepter tout brouillage radioélectrique subi, même si le brouillage est susceptible d'en compromettre le fonctionnement.

Concerning EVMs Including Detachable Antennas:

Under Industry Canada regulations, this radio transmitter may only operate using an antenna of a type and maximum (or lesser) gain approved for the transmitter by Industry Canada. To reduce potential radio interference to other users, the antenna type and its gain should be so chosen that the equivalent isotropically radiated power (e.i.r.p.) is not more than that necessary for successful communication. This radio transmitter has been approved by Industry Canada to operate with the antenna types listed in the user guide with the maximum permissible gain and required antenna impedance for each antenna type indicated. Antenna types not included in this list, having a gain greater than the maximum gain indicated for that type, are strictly prohibited for use with this device.

Concernant les EVMs avec antennes détachables

Conformément à la réglementation d'Industrie Canada, le présent émetteur radio peut fonctionner avec une antenne d'un type et d'un gain maximal (ou inférieur) approuvé pour l'émetteur par Industrie Canada. Dans le but de réduire les risques de brouillage radioélectrique à l'intention des autres utilisateurs, il faut choisir le type d'antenne et son gain de sorte que la puissance isotrope rayonnée équivalente (p.i.r.e.) ne dépasse pas l'intensité nécessaire à l'établissement d'une communication satisfaisante. Le présent émetteur radio a été approuvé par Industrie Canada pour fonctionner avec les types d'antenne énumérés dans le manuel d'usage et ayant un gain admissible maximal et l'impédance requise pour chaque type d'antenne. Les types d'antenne non inclus dans cette liste, ou dont le gain est supérieur au gain maximal indiqué, sont strictement interdits pour l'exploitation de l'émetteur.

3.3 Japan

3.3.1 *Notice for EVMs delivered in Japan:* Please see http://www.tij.co.jp/lstds/ti_ja/general/eStore/notice_01.page 日本国内に輸入される評価用キット、ボードについては、次のところをご覧ください。

<https://www.ti.com/ja-jp/legal/notice-for-evaluation-kits-delivered-in-japan.html>

3.3.2 *Notice for Users of EVMs Considered "Radio Frequency Products" in Japan:* EVMs entering Japan may not be certified by TI as conforming to Technical Regulations of Radio Law of Japan.

If User uses EVMs in Japan, not certified to Technical Regulations of Radio Law of Japan, User is required to follow the instructions set forth by Radio Law of Japan, which includes, but is not limited to, the instructions below with respect to EVMs (which for the avoidance of doubt are stated strictly for convenience and should be verified by User):

1. Use EVMs in a shielded room or any other test facility as defined in the notification #173 issued by Ministry of Internal Affairs and Communications on March 28, 2006, based on Sub-section 1.1 of Article 6 of the Ministry's Rule for Enforcement of Radio Law of Japan,
2. Use EVMs only after User obtains the license of Test Radio Station as provided in Radio Law of Japan with respect to EVMs, or
3. Use of EVMs only after User obtains the Technical Regulations Conformity Certification as provided in Radio Law of Japan with respect to EVMs. Also, do not transfer EVMs, unless User gives the same notice above to the transferee. Please note that if User does not follow the instructions above, User will be subject to penalties of Radio Law of Japan.

【無線電波を送信する製品の開発キットをお使いになる際の注意事項】 開発キットの中には技術基準適合証明を受けていないものがあります。技術適合証明を受けていないものご使用に際しては、電波法遵守のため、以下のいずれかの措置を取っていただく必要がありますのでご注意ください。

1. 電波法施行規則第6条第1項第1号に基づく平成18年3月28日総務省告示第173号で定められた電波暗室等の試験設備でご使用いただく。
2. 実験局の免許を取得後ご使用いただく。
3. 技術基準適合証明を取得後ご使用いただく。

なお、本製品は、上記の「ご使用にあたっての注意」を譲渡先、移転先に通知しない限り、譲渡、移転できないものとします。

上記を遵守頂けない場合は、電波法の罰則が適用される可能性があることをご留意ください。日本テキサス・イ

ンスツルメンツ株式会社

東京都新宿区西新宿 6 丁目 2 4 番 1 号

西新宿三井ビル

3.3.3 *Notice for EVMs for Power Line Communication:* Please see http://www.tij.co.jp/lstds/ti_ja/general/eStore/notice_02.page

電力線搬送波通信についての開発キットをお使いになる際の注意事項については、次のところをご覧ください。 <https://www.ti.com/ja-jp/legal/notice-for-evaluation-kits-for-power-line-communication.html>

3.4 European Union

3.4.1 *For EVMs subject to EU Directive 2014/30/EU (Electromagnetic Compatibility Directive):*

This is a class A product intended for use in environments other than domestic environments that are connected to a low-voltage power-supply network that supplies buildings used for domestic purposes. In a domestic environment this product may cause radio interference in which case the user may be required to take adequate measures.

-
4. *EVM Use Restrictions and Warnings:*
 - 4.1 EVMS ARE NOT FOR USE IN FUNCTIONAL SAFETY AND/OR SAFETY CRITICAL EVALUATIONS, INCLUDING BUT NOT LIMITED TO EVALUATIONS OF LIFE SUPPORT APPLICATIONS.
 - 4.2 User must read and apply the user guide and other available documentation provided by TI regarding the EVM prior to handling or using the EVM, including without limitation any warning or restriction notices. The notices contain important safety information related to, for example, temperatures and voltages.
 - 4.3 *Safety-Related Warnings and Restrictions:*
 - 4.3.1 User shall operate the EVM within TI's recommended specifications and environmental considerations stated in the user guide, other available documentation provided by TI, and any other applicable requirements and employ reasonable and customary safeguards. Exceeding the specified performance ratings and specifications (including but not limited to input and output voltage, current, power, and environmental ranges) for the EVM may cause personal injury or death, or property damage. If there are questions concerning performance ratings and specifications, User should contact a TI field representative prior to connecting interface electronics including input power and intended loads. Any loads applied outside of the specified output range may also result in unintended and/or inaccurate operation and/or possible permanent damage to the EVM and/or interface electronics. Please consult the EVM user guide prior to connecting any load to the EVM output. If there is uncertainty as to the load specification, please contact a TI field representative. During normal operation, even with the inputs and outputs kept within the specified allowable ranges, some circuit components may have elevated case temperatures. These components include but are not limited to linear regulators, switching transistors, pass transistors, current sense resistors, and heat sinks, which can be identified using the information in the associated documentation. When working with the EVM, please be aware that the EVM may become very warm.
 - 4.3.2 EVMs are intended solely for use by technically qualified, professional electronics experts who are familiar with the dangers and application risks associated with handling electrical mechanical components, systems, and subsystems. User assumes all responsibility and liability for proper and safe handling and use of the EVM by User or its employees, affiliates, contractors or designees. User assumes all responsibility and liability to ensure that any interfaces (electronic and/or mechanical) between the EVM and any human body are designed with suitable isolation and means to safely limit accessible leakage currents to minimize the risk of electrical shock hazard. User assumes all responsibility and liability for any improper or unsafe handling or use of the EVM by User or its employees, affiliates, contractors or designees.
 - 4.4 User assumes all responsibility and liability to determine whether the EVM is subject to any applicable international, federal, state, or local laws and regulations related to User's handling and use of the EVM and, if applicable, User assumes all responsibility and liability for compliance in all respects with such laws and regulations. User assumes all responsibility and liability for proper disposal and recycling of the EVM consistent with all applicable international, federal, state, and local requirements.
 5. *Accuracy of Information:* To the extent TI provides information on the availability and function of EVMs, TI attempts to be as accurate as possible. However, TI does not warrant the accuracy of EVM descriptions, EVM availability or other information on its websites as accurate, complete, reliable, current, or error-free.
 6. *Disclaimers:*
 - 6.1 EXCEPT AS SET FORTH ABOVE, EVMS AND ANY MATERIALS PROVIDED WITH THE EVM (INCLUDING, BUT NOT LIMITED TO, REFERENCE DESIGNS AND THE DESIGN OF THE EVM ITSELF) ARE PROVIDED "AS IS" AND "WITH ALL FAULTS." TI DISCLAIMS ALL OTHER WARRANTIES, EXPRESS OR IMPLIED, REGARDING SUCH ITEMS, INCLUDING BUT NOT LIMITED TO ANY EPIDEMIC FAILURE WARRANTY OR IMPLIED WARRANTIES OF MERCHANTABILITY OR FITNESS FOR A PARTICULAR PURPOSE OR NON-INFRINGEMENT OF ANY THIRD PARTY PATENTS, COPYRIGHTS, TRADE SECRETS OR OTHER INTELLECTUAL PROPERTY RIGHTS.
 - 6.2 EXCEPT FOR THE LIMITED RIGHT TO USE THE EVM SET FORTH HEREIN, NOTHING IN THESE TERMS SHALL BE CONSTRUED AS GRANTING OR CONFERRING ANY RIGHTS BY LICENSE, PATENT, OR ANY OTHER INDUSTRIAL OR INTELLECTUAL PROPERTY RIGHT OF TI, ITS SUPPLIERS/LICENSORS OR ANY OTHER THIRD PARTY, TO USE THE EVM IN ANY FINISHED END-USER OR READY-TO-USE FINAL PRODUCT, OR FOR ANY INVENTION, DISCOVERY OR IMPROVEMENT, REGARDLESS OF WHEN MADE, CONCEIVED OR ACQUIRED.
 7. *USER'S INDEMNITY OBLIGATIONS AND REPRESENTATIONS.* USER WILL DEFEND, INDEMNIFY AND HOLD TI, ITS LICENSORS AND THEIR REPRESENTATIVES HARMLESS FROM AND AGAINST ANY AND ALL CLAIMS, DAMAGES, LOSSES, EXPENSES, COSTS AND LIABILITIES (COLLECTIVELY, "CLAIMS") ARISING OUT OF OR IN CONNECTION WITH ANY HANDLING OR USE OF THE EVM THAT IS NOT IN ACCORDANCE WITH THESE TERMS. THIS OBLIGATION SHALL APPLY WHETHER CLAIMS ARISE UNDER STATUTE, REGULATION, OR THE LAW OF TORT, CONTRACT OR ANY OTHER LEGAL THEORY, AND EVEN IF THE EVM FAILS TO PERFORM AS DESCRIBED OR EXPECTED.
-

8. *Limitations on Damages and Liability:*

8.1 *General Limitations.* IN NO EVENT SHALL TI BE LIABLE FOR ANY SPECIAL, COLLATERAL, INDIRECT, PUNITIVE, INCIDENTAL, CONSEQUENTIAL, OR EXEMPLARY DAMAGES IN CONNECTION WITH OR ARISING OUT OF THESE TERMS OR THE USE OF THE EVMS , REGARDLESS OF WHETHER TI HAS BEEN ADVISED OF THE POSSIBILITY OF SUCH DAMAGES. EXCLUDED DAMAGES INCLUDE, BUT ARE NOT LIMITED TO, COST OF REMOVAL OR REINSTALLATION, ANCILLARY COSTS TO THE PROCUREMENT OF SUBSTITUTE GOODS OR SERVICES, RETESTING, OUTSIDE COMPUTER TIME, LABOR COSTS, LOSS OF GOODWILL, LOSS OF PROFITS, LOSS OF SAVINGS, LOSS OF USE, LOSS OF DATA, OR BUSINESS INTERRUPTION. NO CLAIM, SUIT OR ACTION SHALL BE BROUGHT AGAINST TI MORE THAN TWELVE (12) MONTHS AFTER THE EVENT THAT GAVE RISE TO THE CAUSE OF ACTION HAS OCCURRED.

8.2 *Specific Limitations.* IN NO EVENT SHALL TI'S AGGREGATE LIABILITY FROM ANY USE OF AN EVM PROVIDED HEREUNDER, INCLUDING FROM ANY WARRANTY, INDEMNITY OR OTHER OBLIGATION ARISING OUT OF OR IN CONNECTION WITH THESE TERMS, , EXCEED THE TOTAL AMOUNT PAID TO TI BY USER FOR THE PARTICULAR EVM(S) AT ISSUE DURING THE PRIOR TWELVE (12) MONTHS WITH RESPECT TO WHICH LOSSES OR DAMAGES ARE CLAIMED. THE EXISTENCE OF MORE THAN ONE CLAIM SHALL NOT ENLARGE OR EXTEND THIS LIMIT.

9. *Return Policy.* Except as otherwise provided, TI does not offer any refunds, returns, or exchanges. Furthermore, no return of EVM(s) will be accepted if the package has been opened and no return of the EVM(s) will be accepted if they are damaged or otherwise not in a resalable condition. If User feels it has been incorrectly charged for the EVM(s) it ordered or that delivery violates the applicable order, User should contact TI. All refunds will be made in full within thirty (30) working days from the return of the components(s), excluding any postage or packaging costs.

10. *Governing Law:* These terms and conditions shall be governed by and interpreted in accordance with the laws of the State of Texas, without reference to conflict-of-laws principles. User agrees that non-exclusive jurisdiction for any dispute arising out of or relating to these terms and conditions lies within courts located in the State of Texas and consents to venue in Dallas County, Texas. Notwithstanding the foregoing, any judgment may be enforced in any United States or foreign court, and TI may seek injunctive relief in any United States or foreign court.

Mailing Address: Texas Instruments, Post Office Box 655303, Dallas, Texas 75265
Copyright © 2023, Texas Instruments Incorporated

重要通知和免责声明

TI“按原样”提供技术和可靠性数据（包括数据表）、设计资源（包括参考设计）、应用或其他设计建议、网络工具、安全信息和其他资源，不保证没有瑕疵且不做任何明示或暗示的担保，包括但不限于对适销性、与某特定用途的适用性或不侵犯任何第三方知识产权的暗示担保。

这些资源可供使用 TI 产品进行设计的熟练开发人员使用。您将自行承担以下全部责任：(1) 针对您的应用选择合适的 TI 产品，(2) 设计、验证并测试您的应用，(3) 确保您的应用满足相应标准以及任何其他安全、安保法规或其他要求。

这些资源如有变更，恕不另行通知。TI 授权您仅可将这些资源用于研发本资源所述的 TI 产品的相关应用。严禁以其他方式对这些资源进行复制或展示。您无权使用任何其他 TI 知识产权或任何第三方知识产权。对于因您对这些资源的使用而对 TI 及其代表造成的任何索赔、损害、成本、损失和债务，您将全额赔偿，TI 对此概不负责。

TI 提供的产品受 [TI 销售条款](#)、[TI 通用质量指南](#) 或 [ti.com](#) 上其他适用条款或 TI 产品随附的其他适用条款的约束。TI 提供这些资源并不会扩展或以其他方式更改 TI 针对 TI 产品发布的适用的担保或担保免责声明。除非德州仪器 (TI) 明确将某产品指定为定制产品或客户特定产品，否则其产品均为按确定价格收入目录的标准通用器件。

TI 反对并拒绝您可能提出的任何其他或不同的条款。

版权所有 © 2026，德州仪器 (TI) 公司

最后更新日期：2025 年 10 月