

EVM User's Guide: TCA984649-EVM

TCA984649 评估模块



说明

TCA984649-EVM 用于评估 TCA9846 和 TCA9849 的性能。该评估模块 (EVM) 未随附焊接的单元。可以在产品页面底部在线订购样片。该 EVM 可让工程师评估 TCA9846 和 TCA9849 I2C 信号功能。该 EVM 具有一个 USB2ANY 公连接器，可通过 DUT 发送 I2C 信号。USB2ANY 微控制器必须单独购买，此 EVM 未随附。如果使用 USB2ANY 进行通信，则必须以凹口朝上的方式连接电缆。每个引脚的测试点都有多个接地点，以便于使用。负载电容器封装和上拉电阻器等其他功能可用于简化评估和测试。

特性

- 外部电源，在 V_External 和接地端之间带有去耦电容器 (两个 1 μ F 0603)。
- VDD1 和 VDD2 测试点，用于带去耦电容器 (两个 100nF 0603、两个 100pF 0603) 的第二个电源连接选项。
- VDD1 和 VDD2 香蕉插孔插件，用于具有相同去耦电容器 (两个 100nF 0603、两个 100pF 0603) 的第三个电源连接选项。
- 两个 GND 香蕉插孔插件。
- 10 个测试点，用于 I/O。
- 一个 RESET 测试点和两个额外的地址测试点。
- 8 个 GND 测试点，用于探测。
- USB2ANY 公连接器，用于来自微控制器的 I2C 信号源。

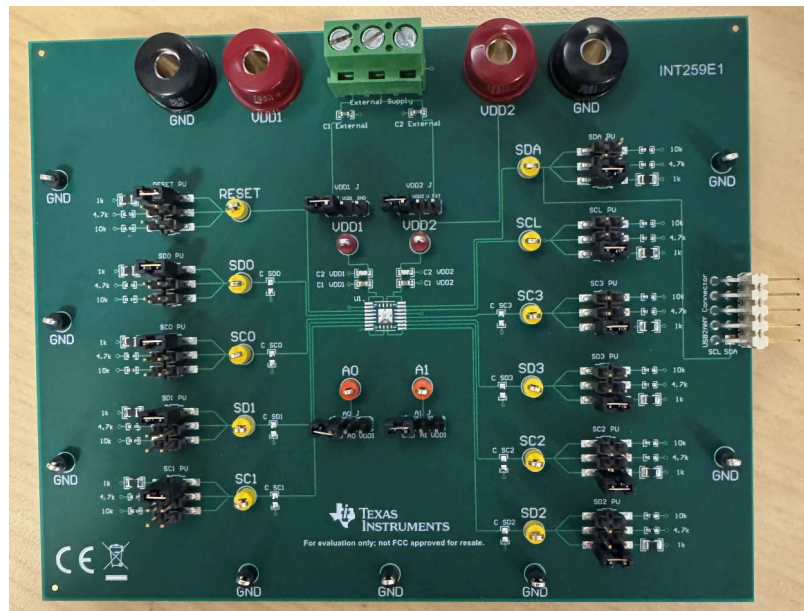

TCA984649-EVM (顶视图)

1 评估模块概述

1.1 简介

本 EVM 介绍了 TCA984649-EVM 评估模块 (EVM) 及其预期用途。该电路板支持对采用 PW 和 QFN 封装的 TI TCA9846 和 TCA9849 开关/多路复用器进行快速原型设计和表征。

EVM 具有以下附加功能：

- 两个 3 引脚接头，用于连接或断开器件与外部电源。
- 两个 3 引脚接头，用于设置器件的地址。
- 11 个 3 通道 3 引脚接头，用于通过所需的电阻值上拉总线。
- 多个未安装负载电容器的封装结构，用于提供潜在的额外总线电容。

1.2 套件内容

该 EVM 套件包括以下内容：

- (1) TCA984649-EVM

1.3 规格

TCA984649-EVM 用于评估 TCA9846 和 TCA9849。该 EVM 具有四个 3 引脚接头和两个用于 VDD1 和 VDD2 电源的接头，这些接头可以连接到外部源或电路板接地端。两个接头，用于将地址 A0 和 A1 引脚设置为高电平或低电平。额外的 11 个 3 通道 3 引脚接头，可选择使用跳线通过 1k、4.7k 或 10k 电阻器将总线上拉至 VDD1。

该 EVM 在每个 I/O 上都有测试点（总共 11 个），两个电源有两个测试点，两个地址引脚有两个测试点。八个接地测试点，用于实现更灵活的电路板连接。



图 1-1. TCA9846 简化电路



图 1-2. TCA9849 简化电路

1.4 器件信息

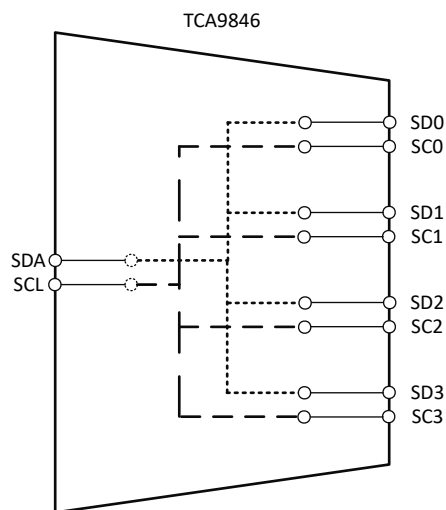
TCA9846 和 TCA9849 是带内 I2C 控制的开关和多路复用器。通道开关和切换由也通过 I/O 的 I2C 总线进行控制。TCA9846 和 TCA9849 都有 4 条通道，但采用多路复用器和开关配置。这些器件使用 1.65V 至 3.6V 的单电源供电，并具有 0.65V 至 3.3V 的电压转换功能。

TCA9846 和 TCA9849 还能够在 I2C 快速模式增强版运行，其额定工作带宽为 1MHz，可支持 I2C 应用中更高速度的信号传输。

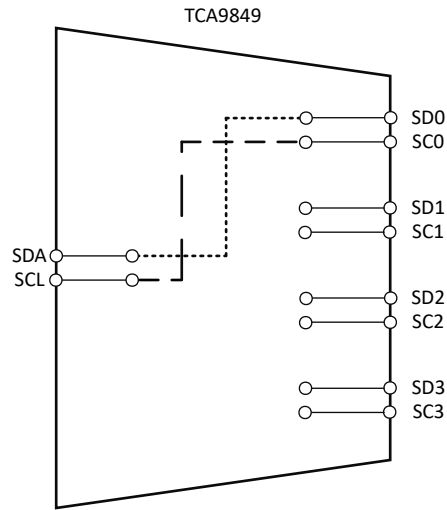
2 硬件

2.1 电源要求

TCA984649-EVM 需要 1.65V 至 3.6V 电源，通过外部电源、香蕉插孔插件或直接连接到红色 VDD 测试点来提供。器件的电源电压不得悬空。

2.2 接头和跳线信息

TCA984649-EVM 具有四个 3 引脚接头和 11 个 3x2 接头，用于设置电源连接、地址和上拉电阻器。下述是每个接头的说明。

1. VDD1 J 接头

接头 VDD1 J 通过跳线将 VDD1 引脚连接到外部电源或接地。如果该接头未连接，则器件电源保持悬空。图 2-1 展示了接头 VDD1 J。

- a. 要连接到外部电源，请短接该接头上的 J1-2 位置。外部电源端子现在为器件供电。
- b. 要接地，请短接该接头上的 J2-3 位置。器件 VDD1 电源引脚现已接地。

2. VDD2 J 接头

接头 VDD2 J 通过跳线将 VDD2 引脚连接到外部电源或接地。如果该接头未连接，则器件电源保持悬空。图 2-1 展示了接头 VDD2 J。

- a. 要连接到外部电源，请短接该接头上的 J2-3 位置。外部电源端子现在为器件供电。
- b. 要接地，请短接该接头上的 J1-2 位置。器件 VDD2 电源引脚现已接地。

3. A0 J 接头

接头 A0 J 通过跳线将地址引脚 A0 连接到 VDD1 或接地。该引脚不得悬空。

- a. 要连接到 VDD1，请短接该接头上的 J2-3 位置。A0 已连接到 VDD1。
- b. 要连接到 GND，请短接该接头上的 J2-1 位置。A0 引脚现已接地。

4. A1 J 接头

接头 A1 J 通过跳线将地址引脚 A1 连接到 VDD1 或接地。该引脚不得悬空。

- a. 要连接到 VDD1，请短接该接头上的 J2-3 位置。A1 已连接到 VDD1。
- b. 要连接到 GND，请短接该接头上的 J2-1 位置。A1 引脚现已接地。

5. 3x2 接头“引脚名称” PU

3x2 接头连接到器件的每个 I/O。每个接头都可以通过三种不同的电阻器选项上拉该线路：1k、4.7k 和 10k。强烈建议使用上述值之一上拉该线路，因为 I2C 总线不能保持悬空。

- a. 要连接到 1k 上拉电阻，请在接头顶行插入跳线。如果接头置于电路板右侧，则插入底部一行。
- b. 要连接到 4.7k 上拉电阻，请在接头中间一行插入跳线。
- c. 要连接到 10k 上拉电阻，请在接头底部一行插入跳线。如果接头置于电路板右侧，则插入顶部一行。



图 2-1. 接头 VDD1 J : J-1 (外部电源)、J-2 (连接到器件 VDD1)、J-3 (GND)



图 2-2. 接头 VDD2 J : J-1 (GND)、J-2 (连接到器件 VDD2)、J-3 (外部电源)

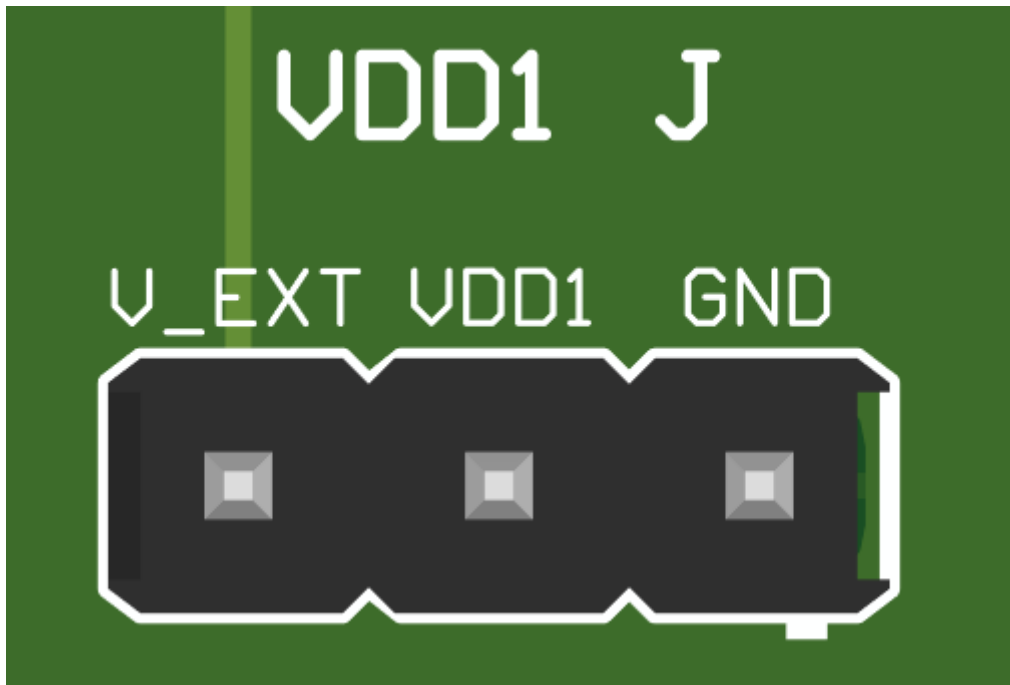

图 2-3. 接头 A0 J : J-1 (GND)、J-2 (连接到器件 A0)、J-3 (VDD1)

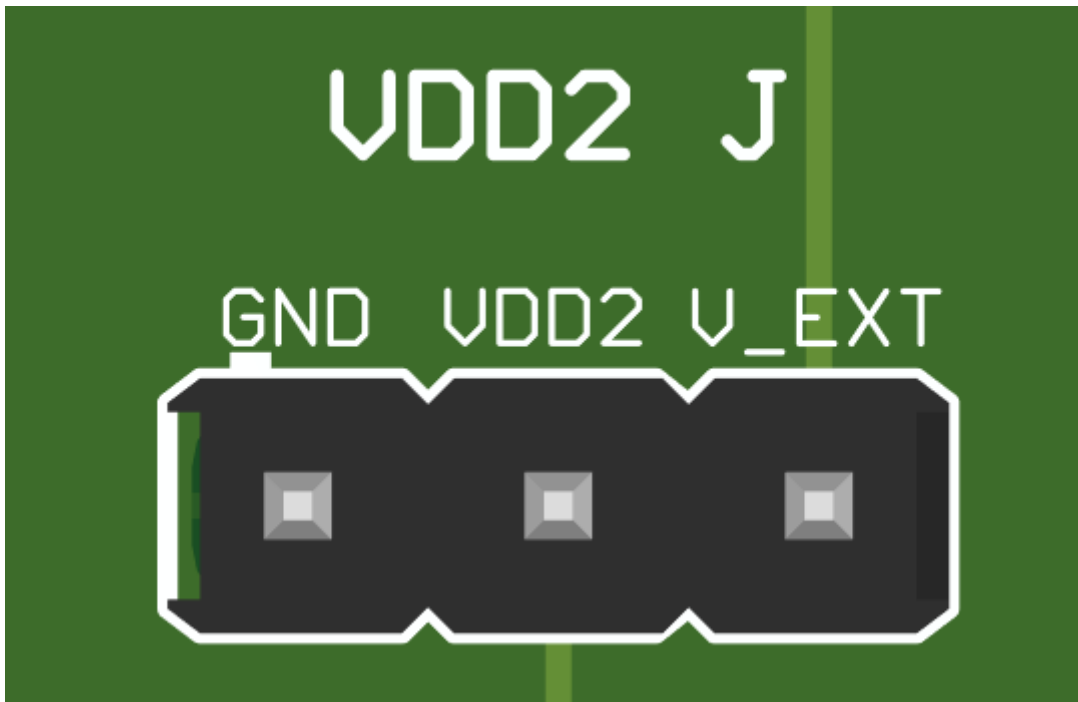

图 2-4. 接头 A1 J : J-1 (GND)、J-2 (连接到器件 A1)、J-3 (VDD1)

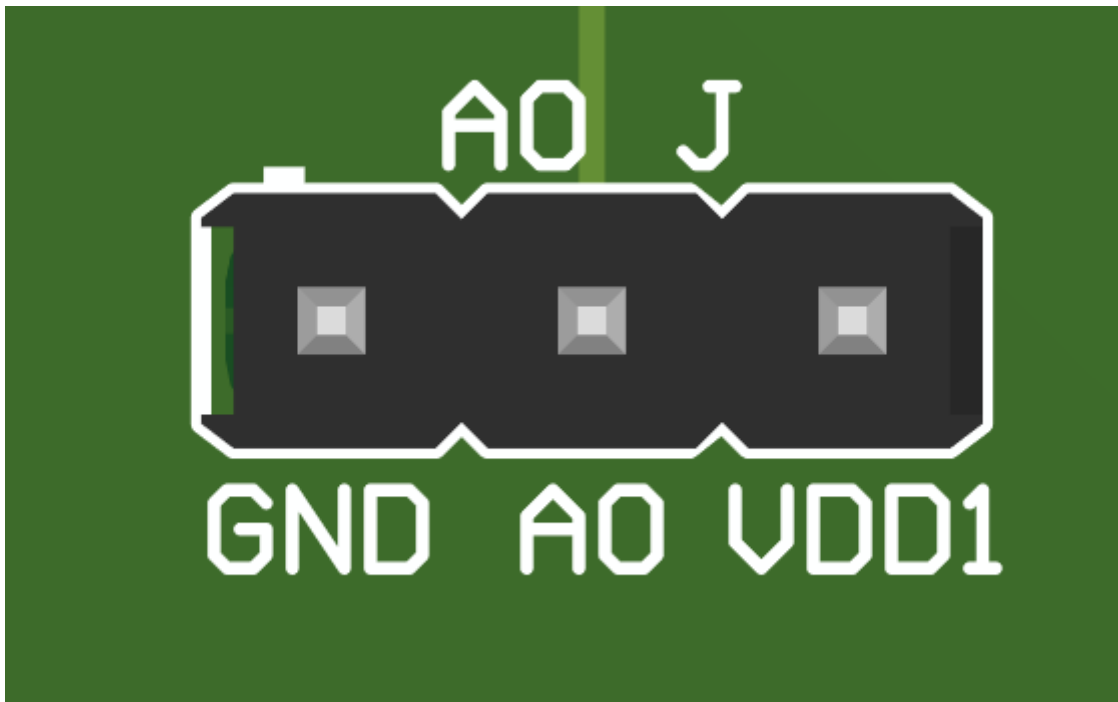

图 2-5. 接头 3x2 复位 PU : 顶部 (复位-1k)、中间 (复位-4.7k)、底部 (复位-10k)

2.3 测试点

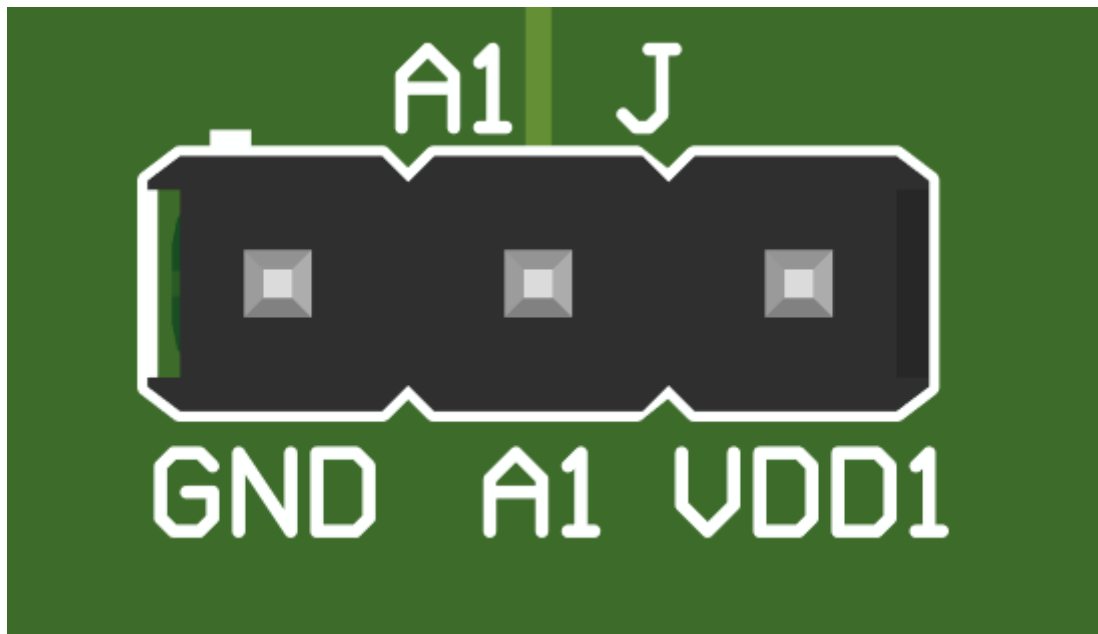
该电路板共有 23 个测试点。8 个 GND，2 个地址，2 个 VDD 和 11 个 I/O。

测试点 ID	说明	信号
复位	黄色 TP	复位
SD0	黄色 TP	SD0
SC0	黄色 TP	SC0
SD1	黄色 TP	SD1
SC1	黄色 TP	SC1
SDA	黄色 TP	SDA
SCL	黄色 TP	SCL
SC3	黄色 TP	SC3
SD3	黄色 TP	SD3
SC2	黄色 TP	SC2
SD2	黄色 TP	SD2
A0	橙色 TP	A0
A1	橙色 TP	A1
VDD1	红色 TP	VDD1
VDD2	红色 TP	VDD2
GND	黑色 TP	GND
GND	黑色 TP	GND
GND	黑色 TP	GND
GND	黑色 TP	GND
GND	黑色 TP	GND
GND	黑色 TP	GND
GND	黑色 TP	GND
GND	黑色 TP	GND

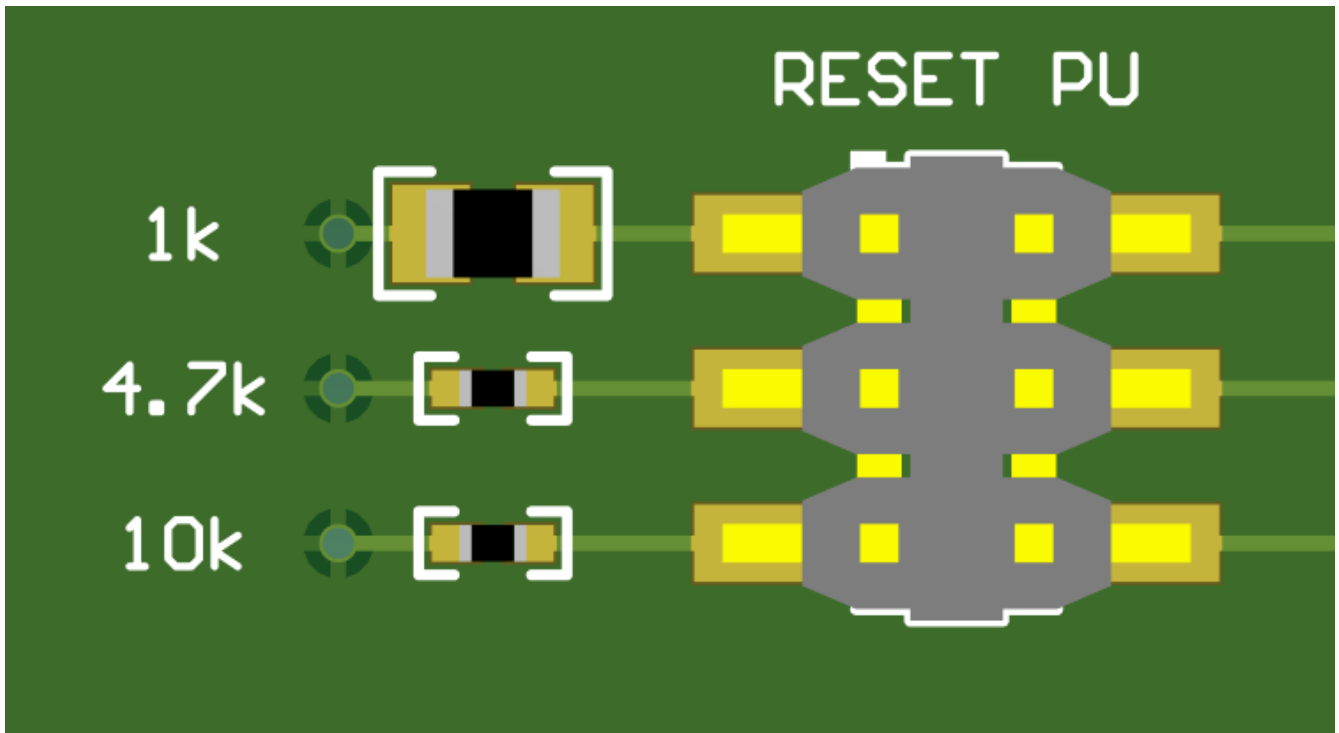
3 硬件设计文件

以下部分包括 TCA984649-EVM 的硬件设计文件。本节包含板级原理图、PCB 布局和物料清单 (BOM)。

3.1 原理图



图 3-1. TCA984649-EVM 原理图

3.2 PCB 布局

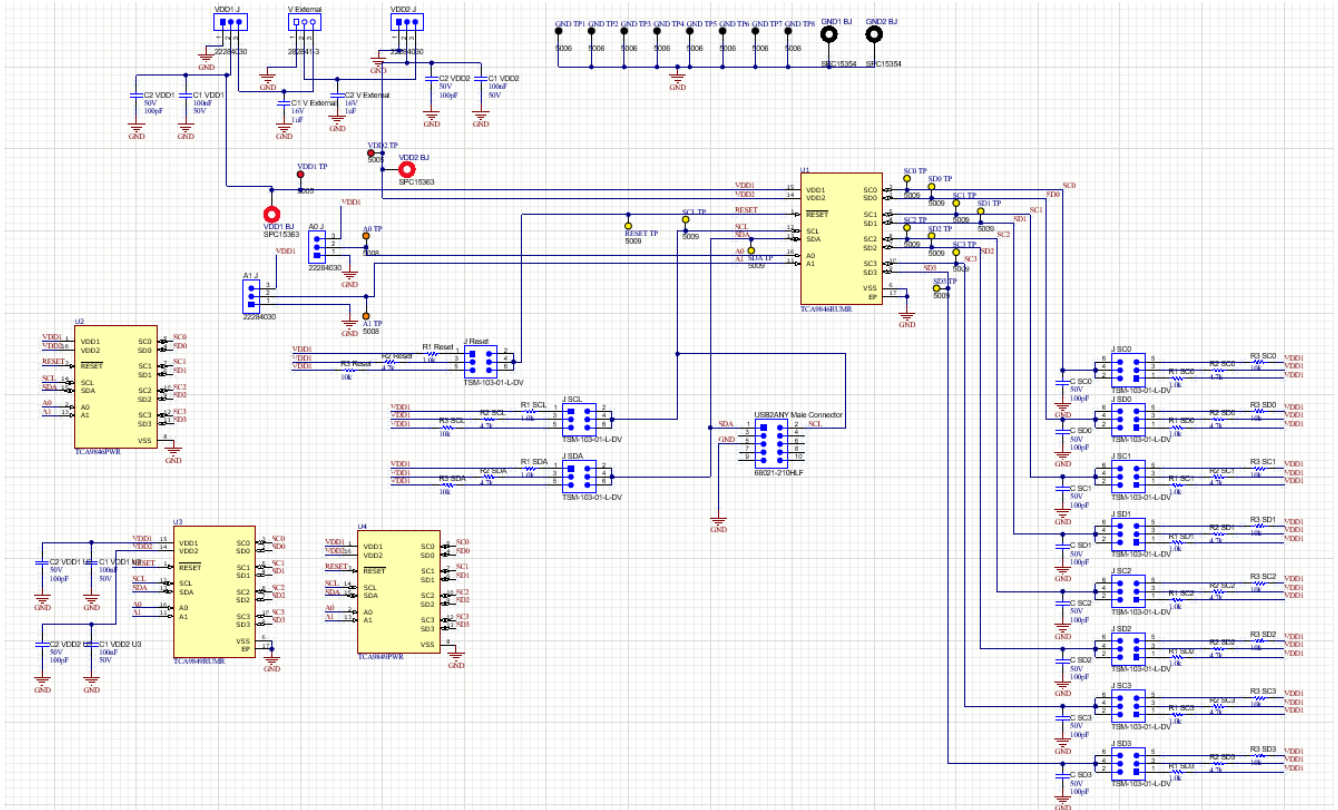

图 3-2. TCA984649-EVM 顶层布局

3.3 物料清单 (BOM)

表 3-1. 物料清单

位号	数量	值	说明	制造商	器件型号
A0 J、A1 J、VDD1 J、VDD2 J	4		接头, 2.54mm, 3x1, 锡, TH	Molex	22284030
A0 TP、A1 TP	2		测试点, 紧凑型, 橙色, TH	Keystone Electronics	5008
B1、B2、B3、B4	4		圆柱形缓冲器, 圆顶直径 0.720" (18.30mm), 黑色聚氨酯材质	Essentra Components	RBS-37BK
C1 V 外部、C2 V 外部	2	1uF	电容, 陶瓷, 1uF, 16V, +/-10%, X5R, 0603	Kemet	C0603C105K4PACTU
C1 VDD1、C1 VDD1 U3、C1 VDD2、C1 VDD2 U3	4	0.1uF	电容, 陶瓷, 0.1uF, 50V, +/-10%, X7R, AEC-Q200 1 级, 0603	Kemet	C0603C104K5RACAUTO
C2 VDD1、C2 VDD1 U3、C2 VDD2、C2 VDD2 U3	4	100pF	电容, 陶瓷, 100pF, 50V, +/-1%, C0G/NP0, 0603	AVX	06035A101FAT2A
GND1 BJ、GND2 BJ	2		香蕉插孔, 焊片, 黑色, TH	Tenma	SPC15354
GND TP1、GND TP2、GND TP3、GND TP4、GND TP5、GND TP6、GND TP7、GND TP8	8		测试点, 紧凑型, 黑色, TH	Keystone Electronics	5006
J1、J2、J3、J4、J5、J6、J7、J8、J9、J10、J11、J12、J13、J14、J15	15		连接器跳线 S2 (1 x 2) 位置分流连接器黑色开孔顶部 0.100"(2.54mm) GoldHORTING .100" 金	Sullins	QPC02SXGN-RC
J 复位、J SC0、J SC1、J SC2、J SC3、J SCL、J SD0、J SD1、J SD2、J SD3、J SDA	11		接头, 2.54mm, 3x2, 金, SMT	Samtec	TSM-103-01-L-DV
R1 复位、R1 SC0、R1 SC1、R1 SC2、R1 SC3、R1 SCL、R1 SD0、R1 SD1、R1 SD2、R1 SD3、R1 SDA	11	1.0k Ω	电阻, 1.0k, 5%, 0.125W, AEC-Q200 0 级, 0805	Panasonic	ERJ-6GEYJ102V
R2 复位、R2 SC0、R2 SC1、R2 SC2、R2 SC3、R2 SCL、R2 SD0、R2 SD1、R2 SD2、R2 SD3、R2 SDA	11	4.7k Ω	电阻, 4.7k, 5%, 0.063W, AEC-Q200 0 级, 0402	Vishay-Dale	CRCW04024K70JNED
R3 复位、R3 SC0、R3 SC1、R3 SC2、R3 SC3、R3 SCL、R3 SD0、R3 SD1、R3 SD2、R3 SD3、R3 SDA	11	10k Ω	电阻, 10k, 5%, 0.063W, AEC-Q200 0 级, 0402	Vishay-Dale	CRCW040210K0JNED

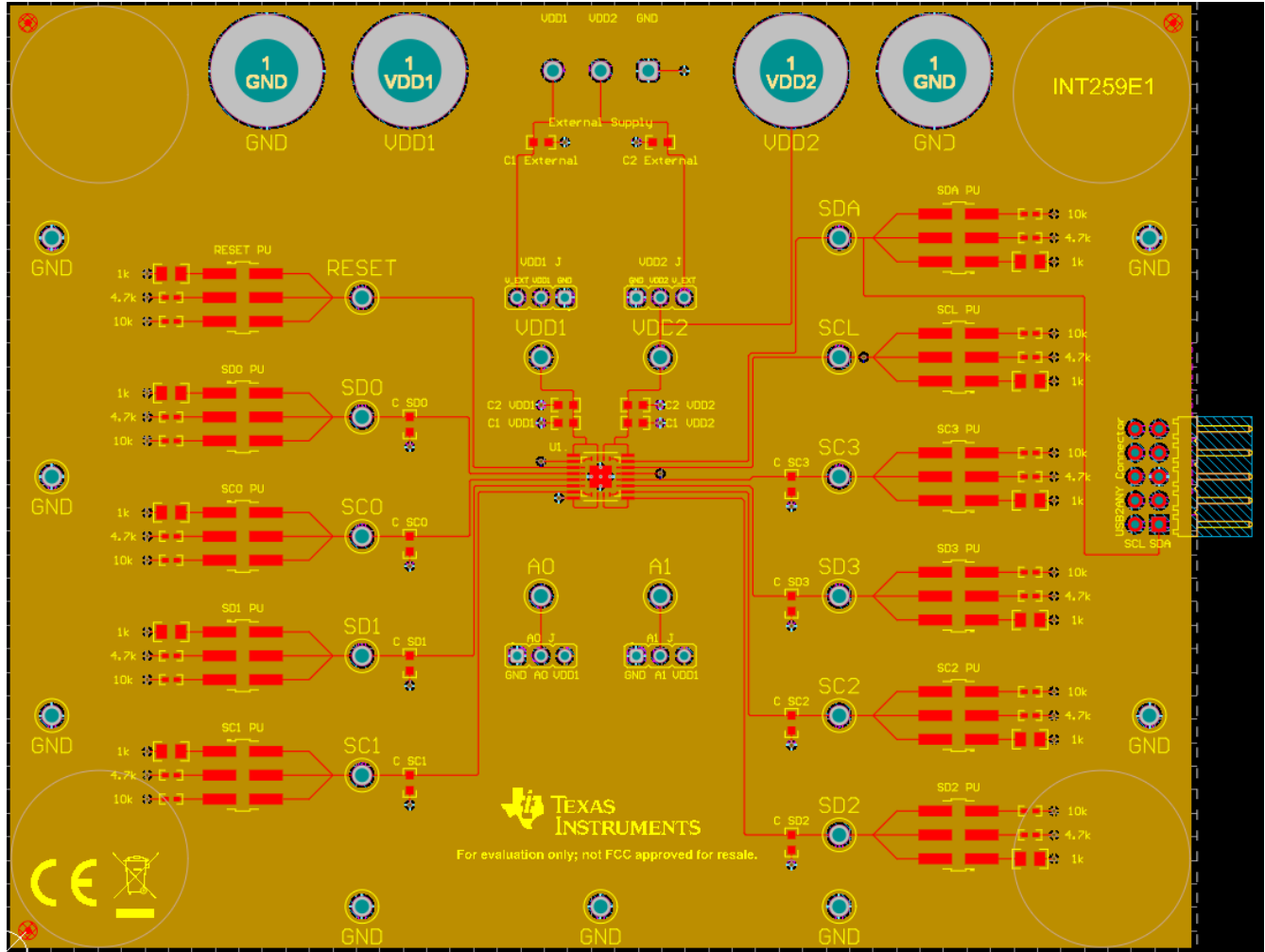
表 3-1. 物料清单 (续)

位号	数量	值	说明	制造商	器件型号
复位 TP、SC0 TP、SC1 TP、SC2 TP、SC3 TP、SCL TP、SD0 TP、SD1 TP、SD2 TP、SD3 TP、SDA TP	11		测试点, 紧凑, 黄色, TH	Keystone Electronics	5009
USB2ANY 公连接器	1		接头, 100mil, 5x2, R/A, 金, TH	FCI	68021-210HLF
V 外部	1		端子块, 5.08mm, 3x1, 锡, TH	TE Connectivity	282841-3
VDD1 BJ、VDD2 BJ	2		香蕉插孔, 焊片, 红色, TH	Tenma	SPC15363
VDD1 TP、VDD2 TP	2		测试点, 紧凑, 红色, TH	Keystone Electronics	5005
C SC0、C SC1、C SC2、C SC3、C SD0、C SD1、C SD2、C SD3	0	100pF	电容, 陶瓷, 100pF, 50V, +/-1%, C0G/NP0, 0603	AVX	06035A101FAT2A
U1	0		TCA9846RUMR	德州仪器 (TI)	TCA9846RUMR
U2	0		TCA9846PWR	德州仪器 (TI)	TCA9846PWR
U3	0		TCA9849RUMR	德州仪器 (TI)	TCA9849RUMR
U4	0		TCA9849PWR	德州仪器 (TI)	TCA9849PWR

4 其他信息

4.1 商标

所有商标均为其各自所有者的财产。

STANDARD TERMS FOR EVALUATION MODULES

1. *Delivery:* TI delivers TI evaluation boards, kits, or modules, including any accompanying demonstration software, components, and/or documentation which may be provided together or separately (collectively, an "EVM" or "EVMs") to the User ("User") in accordance with the terms set forth herein. User's acceptance of the EVM is expressly subject to the following terms.
 - 1.1 EVMs are intended solely for product or software developers for use in a research and development setting to facilitate feasibility evaluation, experimentation, or scientific analysis of TI semiconductors products. EVMs have no direct function and are not finished products. EVMs shall not be directly or indirectly assembled as a part or subassembly in any finished product. For clarification, any software or software tools provided with the EVM ("Software") shall not be subject to the terms and conditions set forth herein but rather shall be subject to the applicable terms that accompany such Software
 - 1.2 EVMs are not intended for consumer or household use. EVMs may not be sold, sublicensed, leased, rented, loaned, assigned, or otherwise distributed for commercial purposes by Users, in whole or in part, or used in any finished product or production system.
2. *Limited Warranty and Related Remedies/Disclaimers:*
 - 2.1 These terms do not apply to Software. The warranty, if any, for Software is covered in the applicable Software License Agreement.
 - 2.2 TI warrants that the TI EVM will conform to TI's published specifications for ninety (90) days after the date TI delivers such EVM to User. Notwithstanding the foregoing, TI shall not be liable for a nonconforming EVM if (a) the nonconformity was caused by neglect, misuse or mistreatment by an entity other than TI, including improper installation or testing, or for any EVMs that have been altered or modified in any way by an entity other than TI, (b) the nonconformity resulted from User's design, specifications or instructions for such EVMs or improper system design, or (c) User has not paid on time. Testing and other quality control techniques are used to the extent TI deems necessary. TI does not test all parameters of each EVM. User's claims against TI under this Section 2 are void if User fails to notify TI of any apparent defects in the EVMs within ten (10) business days after delivery, or of any hidden defects with ten (10) business days after the defect has been detected.
 - 2.3 TI's sole liability shall be at its option to repair or replace EVMs that fail to conform to the warranty set forth above, or credit User's account for such EVM. TI's liability under this warranty shall be limited to EVMs that are returned during the warranty period to the address designated by TI and that are determined by TI not to conform to such warranty. If TI elects to repair or replace such EVM, TI shall have a reasonable time to repair such EVM or provide replacements. Repaired EVMs shall be warranted for the remainder of the original warranty period. Replaced EVMs shall be warranted for a new full ninety (90) day warranty period.

WARNING

Evaluation Kits are intended solely for use by technically qualified, professional electronics experts who are familiar with the dangers and application risks associated with handling electrical mechanical components, systems, and subsystems.

User shall operate the Evaluation Kit within TI's recommended guidelines and any applicable legal or environmental requirements as well as reasonable and customary safeguards. Failure to set up and/or operate the Evaluation Kit within TI's recommended guidelines may result in personal injury or death or property damage. Proper set up entails following TI's instructions for electrical ratings of interface circuits such as input, output and electrical loads.

NOTE:

EXPOSURE TO ELECTROSTATIC DISCHARGE (ESD) MAY CAUSE DEGRADATION OR FAILURE OF THE EVALUATION KIT; TI RECOMMENDS STORAGE OF THE EVALUATION KIT IN A PROTECTIVE ESD BAG.

3 Regulatory Notices:

3.1 United States

3.1.1 Notice applicable to EVMs not FCC-Approved:

FCC NOTICE: This kit is designed to allow product developers to evaluate electronic components, circuitry, or software associated with the kit to determine whether to incorporate such items in a finished product and software developers to write software applications for use with the end product. This kit is not a finished product and when assembled may not be resold or otherwise marketed unless all required FCC equipment authorizations are first obtained. Operation is subject to the condition that this product not cause harmful interference to licensed radio stations and that this product accept harmful interference. Unless the assembled kit is designed to operate under part 15, part 18 or part 95 of this chapter, the operator of the kit must operate under the authority of an FCC license holder or must secure an experimental authorization under part 5 of this chapter.

3.1.2 For EVMs annotated as FCC – FEDERAL COMMUNICATIONS COMMISSION Part 15 Compliant:

CAUTION

This device complies with part 15 of the FCC Rules. Operation is subject to the following two conditions: (1) This device may not cause harmful interference, and (2) this device must accept any interference received, including interference that may cause undesired operation.

Changes or modifications not expressly approved by the party responsible for compliance could void the user's authority to operate the equipment.

FCC Interference Statement for Class A EVM devices

NOTE: This equipment has been tested and found to comply with the limits for a Class A digital device, pursuant to part 15 of the FCC Rules. These limits are designed to provide reasonable protection against harmful interference when the equipment is operated in a commercial environment. This equipment generates, uses, and can radiate radio frequency energy and, if not installed and used in accordance with the instruction manual, may cause harmful interference to radio communications. Operation of this equipment in a residential area is likely to cause harmful interference in which case the user will be required to correct the interference at his own expense.

FCC Interference Statement for Class B EVM devices

NOTE: This equipment has been tested and found to comply with the limits for a Class B digital device, pursuant to part 15 of the FCC Rules. These limits are designed to provide reasonable protection against harmful interference in a residential installation. This equipment generates, uses and can radiate radio frequency energy and, if not installed and used in accordance with the instructions, may cause harmful interference to radio communications. However, there is no guarantee that interference will not occur in a particular installation. If this equipment does cause harmful interference to radio or television reception, which can be determined by turning the equipment off and on, the user is encouraged to try to correct the interference by one or more of the following measures:

- Reorient or relocate the receiving antenna.
- Increase the separation between the equipment and receiver.
- Connect the equipment into an outlet on a circuit different from that to which the receiver is connected.
- Consult the dealer or an experienced radio/TV technician for help.

3.2 Canada

3.2.1 For EVMs issued with an Industry Canada Certificate of Conformance to RSS-210 or RSS-247

Concerning EVMs Including Radio Transmitters:

This device complies with Industry Canada license-exempt RSSs. Operation is subject to the following two conditions:

(1) this device may not cause interference, and (2) this device must accept any interference, including interference that may cause undesired operation of the device.

Concernant les EVMs avec appareils radio:

Le présent appareil est conforme aux CNR d'Industrie Canada applicables aux appareils radio exempts de licence. L'exploitation est autorisée aux deux conditions suivantes: (1) l'appareil ne doit pas produire de brouillage, et (2) l'utilisateur de l'appareil doit accepter tout brouillage radioélectrique subi, même si le brouillage est susceptible d'en compromettre le fonctionnement.

Concerning EVMs Including Detachable Antennas:

Under Industry Canada regulations, this radio transmitter may only operate using an antenna of a type and maximum (or lesser) gain approved for the transmitter by Industry Canada. To reduce potential radio interference to other users, the antenna type and its gain should be so chosen that the equivalent isotropically radiated power (e.i.r.p.) is not more than that necessary for successful communication. This radio transmitter has been approved by Industry Canada to operate with the antenna types listed in the user guide with the maximum permissible gain and required antenna impedance for each antenna type indicated. Antenna types not included in this list, having a gain greater than the maximum gain indicated for that type, are strictly prohibited for use with this device.

Concernant les EVMs avec antennes détachables

Conformément à la réglementation d'Industrie Canada, le présent émetteur radio peut fonctionner avec une antenne d'un type et d'un gain maximal (ou inférieur) approuvé pour l'émetteur par Industrie Canada. Dans le but de réduire les risques de brouillage radioélectrique à l'intention des autres utilisateurs, il faut choisir le type d'antenne et son gain de sorte que la puissance isotrope rayonnée équivalente (p.i.r.e.) ne dépasse pas l'intensité nécessaire à l'établissement d'une communication satisfaisante. Le présent émetteur radio a été approuvé par Industrie Canada pour fonctionner avec les types d'antenne énumérés dans le manuel d'usage et ayant un gain admissible maximal et l'impédance requise pour chaque type d'antenne. Les types d'antenne non inclus dans cette liste, ou dont le gain est supérieur au gain maximal indiqué, sont strictement interdits pour l'exploitation de l'émetteur.

3.3 Japan

3.3.1 *Notice for EVMs delivered in Japan:* Please see http://www.tij.co.jp/lstds/ti_ja/general/eStore/notice_01.page 日本国内に輸入される評価用キット、ボードについては、次のところをご覧ください。

<https://www.ti.com/ja-jp/legal/notice-for-evaluation-kits-delivered-in-japan.html>

3.3.2 *Notice for Users of EVMs Considered "Radio Frequency Products" in Japan:* EVMs entering Japan may not be certified by TI as conforming to Technical Regulations of Radio Law of Japan.

If User uses EVMs in Japan, not certified to Technical Regulations of Radio Law of Japan, User is required to follow the instructions set forth by Radio Law of Japan, which includes, but is not limited to, the instructions below with respect to EVMs (which for the avoidance of doubt are stated strictly for convenience and should be verified by User):

1. Use EVMs in a shielded room or any other test facility as defined in the notification #173 issued by Ministry of Internal Affairs and Communications on March 28, 2006, based on Sub-section 1.1 of Article 6 of the Ministry's Rule for Enforcement of Radio Law of Japan,
2. Use EVMs only after User obtains the license of Test Radio Station as provided in Radio Law of Japan with respect to EVMs, or
3. Use of EVMs only after User obtains the Technical Regulations Conformity Certification as provided in Radio Law of Japan with respect to EVMs. Also, do not transfer EVMs, unless User gives the same notice above to the transferee. Please note that if User does not follow the instructions above, User will be subject to penalties of Radio Law of Japan.

【無線電波を送信する製品の開発キットをお使いになる際の注意事項】 開発キットの中には技術基準適合証明を受けていないものがあります。技術適合証明を受けていないものご使用に際しては、電波法遵守のため、以下のいずれかの措置を取っていただく必要がありますのでご注意ください。

1. 電波法施行規則第6条第1項第1号に基づく平成18年3月28日総務省告示第173号で定められた電波暗室等の試験設備でご使用いただく。
2. 実験局の免許を取得後ご使用いただく。
3. 技術基準適合証明を取得後ご使用いただく。

なお、本製品は、上記の「ご使用にあたっての注意」を譲渡先、移転先に通知しない限り、譲渡、移転できないものとします。

上記を遵守頂けない場合は、電波法の罰則が適用される可能性があることをご留意ください。日本テキサス・イ

ンスツルメンツ株式会社

東京都新宿区西新宿 6 丁目 2 4 番 1 号

西新宿三井ビル

3.3.3 *Notice for EVMs for Power Line Communication:* Please see http://www.tij.co.jp/lstds/ti_ja/general/eStore/notice_02.page

電力線搬送波通信についての開発キットをお使いになる際の注意事項については、次のところをご覧ください。 <https://www.ti.com/ja-jp/legal/notice-for-evaluation-kits-for-power-line-communication.html>

3.4 European Union

3.4.1 *For EVMs subject to EU Directive 2014/30/EU (Electromagnetic Compatibility Directive):*

This is a class A product intended for use in environments other than domestic environments that are connected to a low-voltage power-supply network that supplies buildings used for domestic purposes. In a domestic environment this product may cause radio interference in which case the user may be required to take adequate measures.

-
4. *EVM Use Restrictions and Warnings:*
 - 4.1 EVMS ARE NOT FOR USE IN FUNCTIONAL SAFETY AND/OR SAFETY CRITICAL EVALUATIONS, INCLUDING BUT NOT LIMITED TO EVALUATIONS OF LIFE SUPPORT APPLICATIONS.
 - 4.2 User must read and apply the user guide and other available documentation provided by TI regarding the EVM prior to handling or using the EVM, including without limitation any warning or restriction notices. The notices contain important safety information related to, for example, temperatures and voltages.
 - 4.3 *Safety-Related Warnings and Restrictions:*
 - 4.3.1 User shall operate the EVM within TI's recommended specifications and environmental considerations stated in the user guide, other available documentation provided by TI, and any other applicable requirements and employ reasonable and customary safeguards. Exceeding the specified performance ratings and specifications (including but not limited to input and output voltage, current, power, and environmental ranges) for the EVM may cause personal injury or death, or property damage. If there are questions concerning performance ratings and specifications, User should contact a TI field representative prior to connecting interface electronics including input power and intended loads. Any loads applied outside of the specified output range may also result in unintended and/or inaccurate operation and/or possible permanent damage to the EVM and/or interface electronics. Please consult the EVM user guide prior to connecting any load to the EVM output. If there is uncertainty as to the load specification, please contact a TI field representative. During normal operation, even with the inputs and outputs kept within the specified allowable ranges, some circuit components may have elevated case temperatures. These components include but are not limited to linear regulators, switching transistors, pass transistors, current sense resistors, and heat sinks, which can be identified using the information in the associated documentation. When working with the EVM, please be aware that the EVM may become very warm.
 - 4.3.2 EVMs are intended solely for use by technically qualified, professional electronics experts who are familiar with the dangers and application risks associated with handling electrical mechanical components, systems, and subsystems. User assumes all responsibility and liability for proper and safe handling and use of the EVM by User or its employees, affiliates, contractors or designees. User assumes all responsibility and liability to ensure that any interfaces (electronic and/or mechanical) between the EVM and any human body are designed with suitable isolation and means to safely limit accessible leakage currents to minimize the risk of electrical shock hazard. User assumes all responsibility and liability for any improper or unsafe handling or use of the EVM by User or its employees, affiliates, contractors or designees.
 - 4.4 User assumes all responsibility and liability to determine whether the EVM is subject to any applicable international, federal, state, or local laws and regulations related to User's handling and use of the EVM and, if applicable, User assumes all responsibility and liability for compliance in all respects with such laws and regulations. User assumes all responsibility and liability for proper disposal and recycling of the EVM consistent with all applicable international, federal, state, and local requirements.
 5. *Accuracy of Information:* To the extent TI provides information on the availability and function of EVMs, TI attempts to be as accurate as possible. However, TI does not warrant the accuracy of EVM descriptions, EVM availability or other information on its websites as accurate, complete, reliable, current, or error-free.
 6. *Disclaimers:*
 - 6.1 EXCEPT AS SET FORTH ABOVE, EVMS AND ANY MATERIALS PROVIDED WITH THE EVM (INCLUDING, BUT NOT LIMITED TO, REFERENCE DESIGNS AND THE DESIGN OF THE EVM ITSELF) ARE PROVIDED "AS IS" AND "WITH ALL FAULTS." TI DISCLAIMS ALL OTHER WARRANTIES, EXPRESS OR IMPLIED, REGARDING SUCH ITEMS, INCLUDING BUT NOT LIMITED TO ANY EPIDEMIC FAILURE WARRANTY OR IMPLIED WARRANTIES OF MERCHANTABILITY OR FITNESS FOR A PARTICULAR PURPOSE OR NON-INFRINGEMENT OF ANY THIRD PARTY PATENTS, COPYRIGHTS, TRADE SECRETS OR OTHER INTELLECTUAL PROPERTY RIGHTS.
 - 6.2 EXCEPT FOR THE LIMITED RIGHT TO USE THE EVM SET FORTH HEREIN, NOTHING IN THESE TERMS SHALL BE CONSTRUED AS GRANTING OR CONFERRING ANY RIGHTS BY LICENSE, PATENT, OR ANY OTHER INDUSTRIAL OR INTELLECTUAL PROPERTY RIGHT OF TI, ITS SUPPLIERS/LICENSORS OR ANY OTHER THIRD PARTY, TO USE THE EVM IN ANY FINISHED END-USER OR READY-TO-USE FINAL PRODUCT, OR FOR ANY INVENTION, DISCOVERY OR IMPROVEMENT, REGARDLESS OF WHEN MADE, CONCEIVED OR ACQUIRED.
 7. *USER'S INDEMNITY OBLIGATIONS AND REPRESENTATIONS.* USER WILL DEFEND, INDEMNIFY AND HOLD TI, ITS LICENSORS AND THEIR REPRESENTATIVES HARMLESS FROM AND AGAINST ANY AND ALL CLAIMS, DAMAGES, LOSSES, EXPENSES, COSTS AND LIABILITIES (COLLECTIVELY, "CLAIMS") ARISING OUT OF OR IN CONNECTION WITH ANY HANDLING OR USE OF THE EVM THAT IS NOT IN ACCORDANCE WITH THESE TERMS. THIS OBLIGATION SHALL APPLY WHETHER CLAIMS ARISE UNDER STATUTE, REGULATION, OR THE LAW OF TORT, CONTRACT OR ANY OTHER LEGAL THEORY, AND EVEN IF THE EVM FAILS TO PERFORM AS DESCRIBED OR EXPECTED.

8. *Limitations on Damages and Liability:*

8.1 *General Limitations.* IN NO EVENT SHALL TI BE LIABLE FOR ANY SPECIAL, COLLATERAL, INDIRECT, PUNITIVE, INCIDENTAL, CONSEQUENTIAL, OR EXEMPLARY DAMAGES IN CONNECTION WITH OR ARISING OUT OF THESE TERMS OR THE USE OF THE EVMS , REGARDLESS OF WHETHER TI HAS BEEN ADVISED OF THE POSSIBILITY OF SUCH DAMAGES. EXCLUDED DAMAGES INCLUDE, BUT ARE NOT LIMITED TO, COST OF REMOVAL OR REINSTALLATION, ANCILLARY COSTS TO THE PROCUREMENT OF SUBSTITUTE GOODS OR SERVICES, RETESTING, OUTSIDE COMPUTER TIME, LABOR COSTS, LOSS OF GOODWILL, LOSS OF PROFITS, LOSS OF SAVINGS, LOSS OF USE, LOSS OF DATA, OR BUSINESS INTERRUPTION. NO CLAIM, SUIT OR ACTION SHALL BE BROUGHT AGAINST TI MORE THAN TWELVE (12) MONTHS AFTER THE EVENT THAT GAVE RISE TO THE CAUSE OF ACTION HAS OCCURRED.

8.2 *Specific Limitations.* IN NO EVENT SHALL TI'S AGGREGATE LIABILITY FROM ANY USE OF AN EVM PROVIDED HEREUNDER, INCLUDING FROM ANY WARRANTY, INDEMNITY OR OTHER OBLIGATION ARISING OUT OF OR IN CONNECTION WITH THESE TERMS, , EXCEED THE TOTAL AMOUNT PAID TO TI BY USER FOR THE PARTICULAR EVM(S) AT ISSUE DURING THE PRIOR TWELVE (12) MONTHS WITH RESPECT TO WHICH LOSSES OR DAMAGES ARE CLAIMED. THE EXISTENCE OF MORE THAN ONE CLAIM SHALL NOT ENLARGE OR EXTEND THIS LIMIT.

9. *Return Policy.* Except as otherwise provided, TI does not offer any refunds, returns, or exchanges. Furthermore, no return of EVM(s) will be accepted if the package has been opened and no return of the EVM(s) will be accepted if they are damaged or otherwise not in a resalable condition. If User feels it has been incorrectly charged for the EVM(s) it ordered or that delivery violates the applicable order, User should contact TI. All refunds will be made in full within thirty (30) working days from the return of the components(s), excluding any postage or packaging costs.

10. *Governing Law:* These terms and conditions shall be governed by and interpreted in accordance with the laws of the State of Texas, without reference to conflict-of-laws principles. User agrees that non-exclusive jurisdiction for any dispute arising out of or relating to these terms and conditions lies within courts located in the State of Texas and consents to venue in Dallas County, Texas. Notwithstanding the foregoing, any judgment may be enforced in any United States or foreign court, and TI may seek injunctive relief in any United States or foreign court.

Mailing Address: Texas Instruments, Post Office Box 655303, Dallas, Texas 75265
Copyright © 2023, Texas Instruments Incorporated

重要通知和免责声明

TI“按原样”提供技术和可靠性数据（包括数据表）、设计资源（包括参考设计）、应用或其他设计建议、网络工具、安全信息和其他资源，不保证没有瑕疵且不做任何明示或暗示的担保，包括但不限于对适销性、与某特定用途的适用性或不侵犯任何第三方知识产权的暗示担保。

这些资源可供使用 TI 产品进行设计的熟练开发人员使用。您将自行承担以下全部责任：(1) 针对您的应用选择合适的 TI 产品，(2) 设计、验证并测试您的应用，(3) 确保您的应用满足相应标准以及任何其他安全、安保法规或其他要求。

这些资源如有变更，恕不另行通知。TI 授权您仅可将这些资源用于研发本资源所述的 TI 产品的相关应用。严禁以其他方式对这些资源进行复制或展示。您无权使用任何其他 TI 知识产权或任何第三方知识产权。对于因您对这些资源的使用而对 TI 及其代表造成的任何索赔、损害、成本、损失和债务，您将全额赔偿，TI 对此概不负责。

TI 提供的产品受 [TI 销售条款](#)、[TI 通用质量指南](#) 或 [ti.com](#) 上其他适用条款或 TI 产品随附的其他适用条款的约束。TI 提供这些资源并不会扩展或以其他方式更改 TI 针对 TI 产品发布的适用的担保或担保免责声明。除非德州仪器 (TI) 明确将某产品指定为定制产品或客户特定产品，否则其产品均为按确定价格收入目录的标准通用器件。

TI 反对并拒绝您可能提出的任何其他或不同的条款。

版权所有 © 2026，德州仪器 (TI) 公司

最后更新日期：2025 年 10 月