

1 评估模块概述

1.1 简介

本文档是评估板 (EVM) 的用户指南，用于测试采用发射和接收模式配置的 TRF2001P FEM。需要两根直流电源轨：用于功率放大器的 VOLT_PA_supply (VCC_PA)，以及用于 LNA 和控制信号的 VOLT_3P3V_supply (VCC)。要将器件配置为所需的运行模式，请使用接头 J1 上的跳线设置（请参阅节 1.3）。TRF2001PEVM 运行模式设置均在表 1-1 中显示。

表 1-1. TRF2001PEVM 运行模式设置

模式	控制信号	I/O 配置	注释
启用 TX 路径	CTL0 (CEN) = 1 CTL1 (CIB) = 1 CTL2 (CTR) = 1	PA_IN 连接器上为信号发生器， ANT 连接器上为频谱分析仪	器件配置为射频发射模式
启用 RX 路径	CTL0 (CEN) = 1 CTL1 (CIB) = 1 CTL2 (CTR) = 0	ANT 连接器上为信号发生器，RX 连接器上为频谱分析仪	器件配置为射频接收模式
断电	CTL0 (CEN) = 0 CTL1 (CIB) = 0 CTL2 (CTR) = 0	无操作	器件处于断电状态

本文档还包含原理图（节 3.1）、印刷电路板 (PCB) 布局（节 3.2）、物料清单 (BOM, 节 3.3) 和硬件使用信息（节 2）。本用户指南介绍了正确运行和快速设置 TRF2001PEVM 所需的基本步骤和功能。

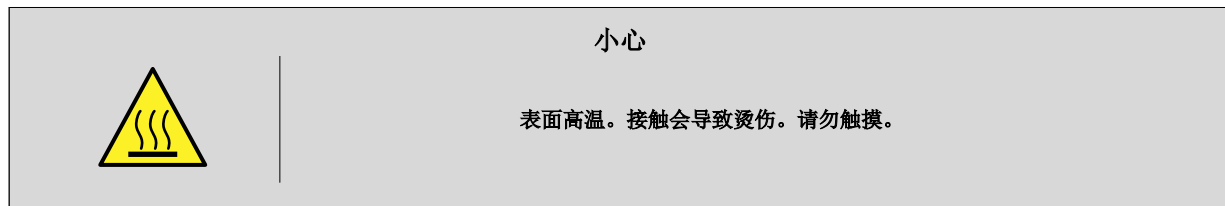

1.2 套件内容

表 1-2 列出了 EVM 套件的内含物。如果缺少任何元件，请与离您最近的德州仪器 (TI) [客户支持中心](#) 联系。

表 1-2. 套件内容

条目	数量
TRF2001PEVM	1

1.3 规格

本节介绍射频连接器和接头 J1 的规格和信息。接头 J1 的每个引脚都有各自的详细丝印。摘要如表 1-3 所示。

表 1-3. 规格

连接器	参数	输入值
PA_IN	PA 射频输入	16dBm 最大值
RX	LNA 射频输出	
ANT (启用 TX 路径)	RF 输出	
ANT (启用 RX 路径)	RF 输入	10dBm 最大值
J1.1	VCC_3P3V	CTL0 (CEN) 控制引脚上拉
J1.2	GND	
J1.3	CTL0	CEN 控制引脚
J1.4	CTL0_DCARD	未使用
J1.5	GND	CTL0 (CEN) 控制引脚下拉
J1.6	VCC_3P3V	CTL1 (CIB) 控制引脚上拉
J1.7	CTL1_DCARD	未使用
J1.8	CTL1	CIB 控制引脚
J1.9	VCC_3P3V	CTL2 (CTR) 控制引脚上拉
J1.10	GND	CIB 控制引脚下拉
J1.11	CTL2	CTR 控制引脚
J1.12	CTL2_DCARD	未使用
J1.13	GND	CTR 控制引脚下拉
J1.14	GND	
J1.15	GND	
J1.16	GND	
J1.17	VOLT_PA_supply	VCC_PA 电源
J1.18	GND	
J1.19	VOLT_PA_supply	VCC_PA 电源
J1.20	GND	
J1.21	VOLT_3P3V_supply	VCC 电源
J1.22	GND	
J1.23	VOLT_3P3V_supply	VCC 电源
J1.24	GND	
J3.1	VDET	监控发射射频功率 (以电压表示)
J3.2	GND	

1.4 器件信息

要了解详细器件信息，请参阅 [TRF2001P](#) 数据表。

2 硬件

2.1 一般使用信息

本节提供 TRF2001PEVM 的一般使用信息。请参阅图 2-1 (TX 路径启用模式的单音设置) 和图 2-2 (RX 路径启用模式的单音设置) 作为以下说明的参考设置 (为清晰起见, 省略了电源旁路电容器等部分元件) :

1. 建议的加电序列 :

- a. 将 VOLT_PA_supply 设置为 3.3V, 将电流限制设置为 900mA。
 - 在 J1.17 (VOLT_PA_supply) 和 J1.18 (GND) 处连接电源。
 - 在 J1.19 (VOLT_PA_supply) 和 J1.20 (GND) 处连接电源检测线路。
- b. 将 VOLT_3P3V_supply 设置为 3.3V, 将电流限制设置为 100mA。
 - 在 J1.21 (VOLT_3P3V_supply) 和 J1.22 (GND) 处连接电源。
 - 在 J1.23 (VOLT_3P3V_supply) 和 J1.24 (GND) 处连接电源检测线路。
- c. 使用 J1 处的跳线设置运行模式 (TX 路径启用、RX 路径启用或断电)。有关如何配置运行模式, 请参阅表 2-1。

表 2-1. 设置运行模式的跳线配置

运行模式	接头 J1 跳线配置	注释
启用 TX 路径	使用跳线连接以下各项 : <ul style="list-style-type: none"> • J1.3 (CTL0/CEN) 至 J1.1 (VCC_3P3V) • J1.8 (CTL1/CIB) 至 J1.6 (VCC_3P3V) • J1.11 (CTL2/CTR) 至 J1.9 (VCC_3P3V) 	如果 PA_IN 处没有射频输入, 则 VOLT_PA_supply (VCC_PA) 处预期电流约为 58mA, VOLT_3P3V_supply (VCC) 处预期电流约为 7mA。
启用 RX 路径	使用跳线连接以下各项 : <ul style="list-style-type: none"> • J1.3 (CTL0/CEN) 至 J1.1 (VCC_3P3V) • J1.8 (CTL1/CIB) 至 J1.6 (VCC_3P3V) • J1.11 (CTL2/CTR) 至 J1.13 (GND) 	如果 ANT 处没有射频输入, 则 VOLT_PA_supply (VCC_PA) 处预期电流约为 0.3mA, VOLT_3P3V_supply (VCC) 处预期电流约为 10mA。
断电	使用跳线连接以下各项 : <ul style="list-style-type: none"> • J1.3 (CTL0/CEN) 至 J1.5 (GND) • J1.8 (CTL1/CIB) 至 J1.10 (GND) • J1.11 (CTL2/CTR) 至 J1.13 (GND) 	器件处于断电状态

2. 断电序列 :

- a. 关闭到 TRF2001PEVM 的射频信号 (PA_IN 和 ANT 连接器)。
- b. 将 VOLT_3P3V_supply 设置为 0V, 然后将 VOLT_PA_supply 设置为 0V。

2.2 单音测量设置

本节提供单音测量设置信息。

1. TX 路径启用模式：

在 TX 路径启用模式下，通过在 PA_IN 连接器处连接信号发生器并在 ANT 连接器处连接功率计，可以测量射频增益。对于 -30dBm 的输入功率，预期增益范围约为 22dB 至 24dB。可记录的信号发生器功率扫描范围为 -30dBm 至 12dBm，并可使用功率计测量输出功率。对于 12dBm 输入功率，预期输出功率范围约为 27dBm 至 28dBm。建议在 ANT 输出端使用 20dB 衰减器垫进行发射测量，以保护功率计或频谱分析仪。另请参阅图 2-1。

2. RX 路径启用模式：

在 RX 路径启用模式下，通过在 ANT 连接器处连接信号发生器并在 RX 连接器处连接功率计，可以测量射频增益。对于 -30dBm 的输入功率，预期增益范围约为 16dB 至 18dB。可记录的信号发生器功率扫描范围为 -30dBm 至 -10dBm，并可使用功率计测量输出功率。对于 -10dBm 输入功率，预期输出功率范围约为 0dBm 至 2dBm。另请参阅图 2-2。



图 2-1. 增益和输出 P1dB 的单音 TX 路径启用设置



图 2-2. 增益和输出 P1dB 的单音 RX 路径启用设置

备注

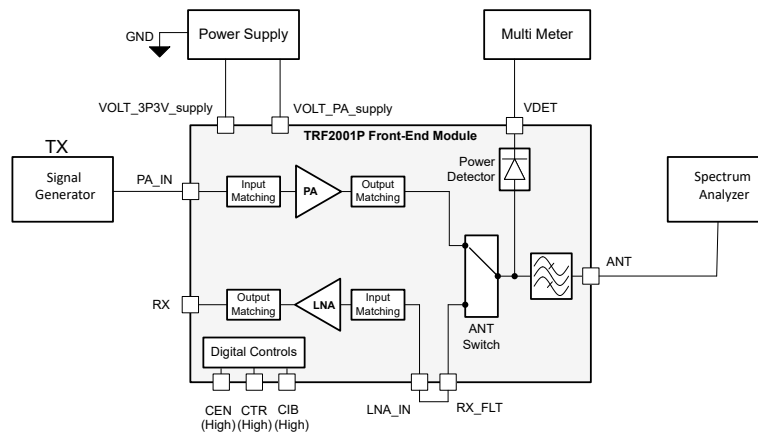
TI 建议您正确表征和补偿射频同轴电缆、衰减器垫和连接器的插入损耗，以便准确测量器件的增益和功率等级。

3 硬件设计文件

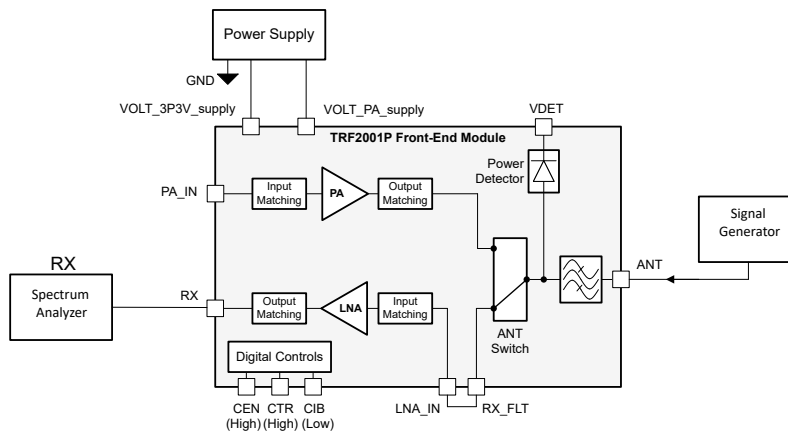
3.1 原理图

图 3-1 显示了 TRF2001PEVM 原理图。



图 3-1. TRF2001PEVM 原理图

3.2 PCB 布局

图 3-2 至 图 3-5 显示了此 EVM 的 PCB 板层。

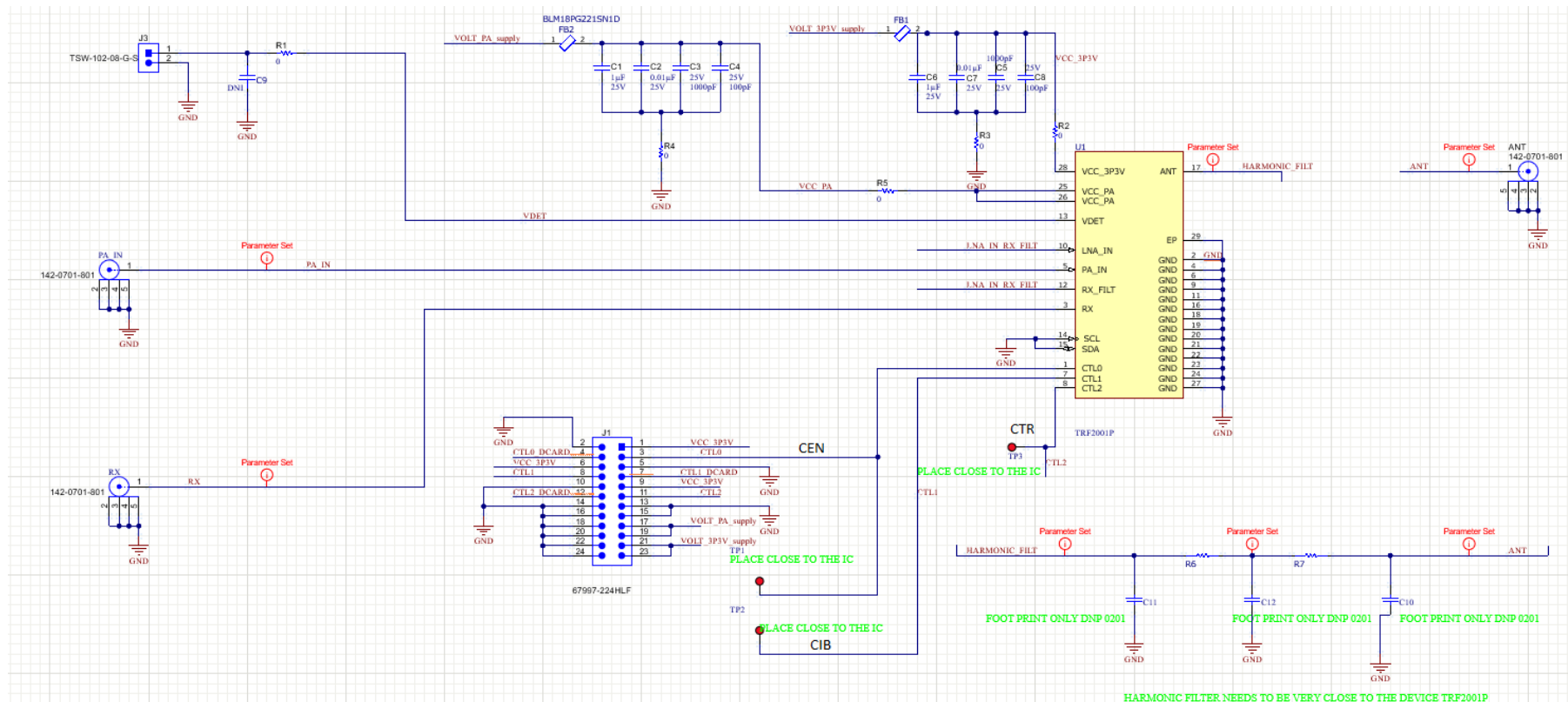

图 3-2. 顶层



图 3-3. 第 2 层

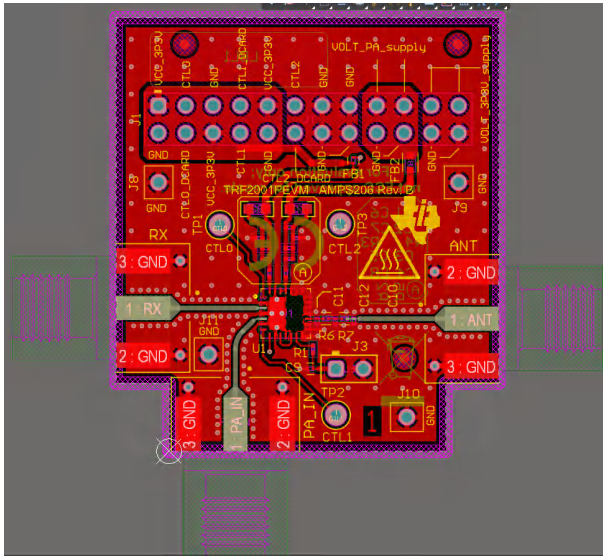

图 3-4. 第 3 层

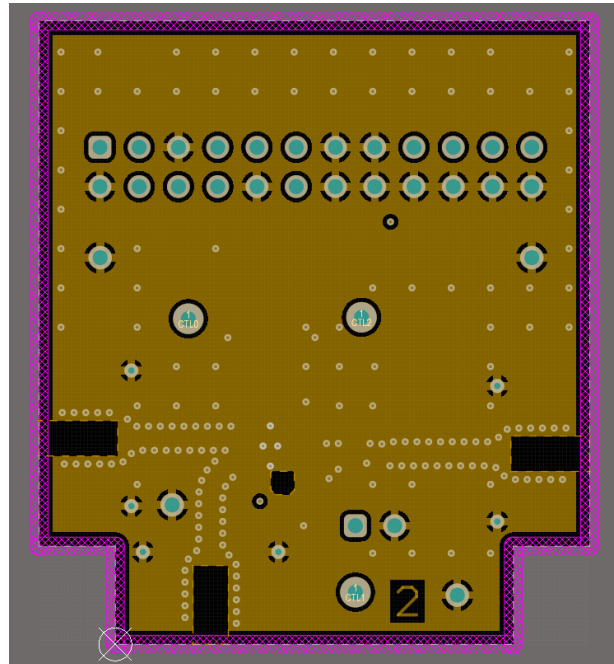

图 3-5. 底层

3.2.1 堆叠和材料

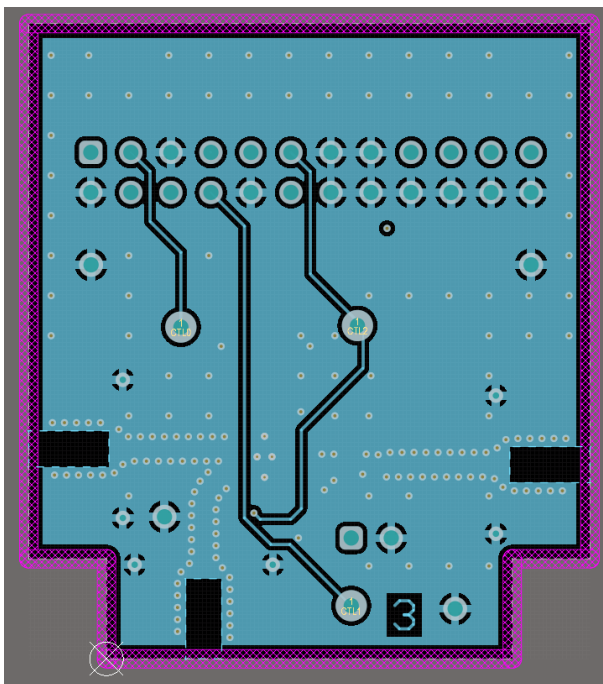
TRF2001PEVM 是一款 61.278mil 4 层电路板，材料类型为 FR-4 370HR。顶层是电源布线、接地布线以及 SMA 连接器与器件之间的信号布线。第二层是参考射频接地层。第三层布置电源信号布线。信号布线阻抗目标为 $50\ \Omega$ 。底部 3 层是接地层。

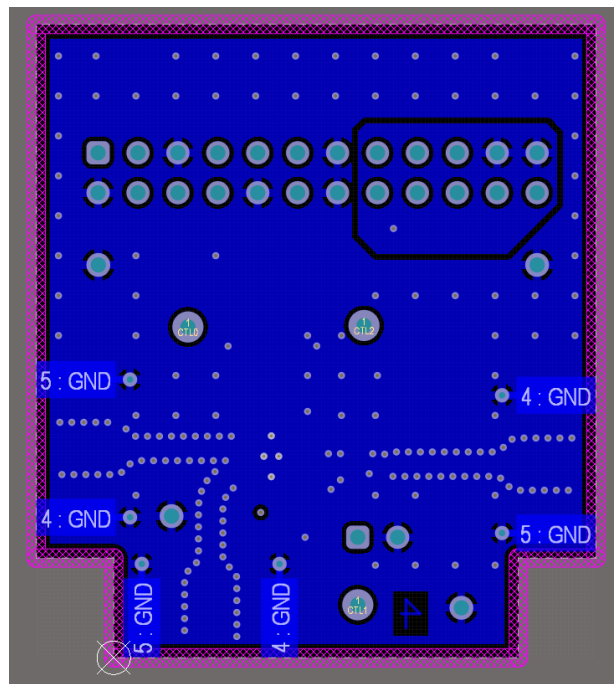

图 3-6. TRF2001PEVM 堆叠 (以 mil 为单位)

3.3 物料清单 (BOM)

表 3-1. 物料清单

条目	位号	数量	值	说明	器件型号	制造商	封装参考
1	!PCB	1		印刷电路板	AMPS206	不限	
2	ANT , PA_IN , RX	3		连接器, 末端发射 SMA, 50 Ω , SMT	142-0701-801	Cinch Connectivity	末端发射 SMA
3	C1、C6	2	1uF	电容, 陶瓷, 1μF , 25V, +/- 10% , X7R , AEC-Q200 1 级, 0603	GCM188R71E105KA 64D	MuRata	0603
4	C2、C7	2	0.01uF	电容, 陶瓷, 0.01μF, 25V, +/- 10% , X7R , 0201	GRM033R71E103KE 14D	MuRata	0201
5	C3、C5	2	1000pF	电容, 陶瓷, 1000pF, 25V , +/-10% , X7R , 0201	GRM033R71E102KA 01D	MuRata	0201
6	C4、C8	2	100pF	电容, 陶瓷, 100pF, 25V , +/-10% , X7R , 0201	GRM033R71E101KA 01D	MuRata	0201
7	FB1	1		铁氧体磁珠, 0201, 120 Ω (100MHz), 25% , 0.23 Ω , 450mA	BLM03AX121SN1D	MuRata	0201
8	FB2	1		芯片铁氧体磁珠, 0603, 220 Ω (100MHz), 0.1 Ω , 25% , 1.4A	BLM18PG221SN1D	Murata	0603
9	J1	1		接头, 2.54mm , 12x2, 金, TH	67997-224HLF	FCI	接头, 2.54mm , 12x2, TH
10	J3	1		接头, 2.54mm , 2x1, 金, TH	TSW-102-08G-S	Samtec	接头, 2.54mm , 2x1 , TH
11	LBL1	1		热转印打印标签, 0.650" (宽) x 0.200" (高) - 10,000/卷	THT-14-423-10	Brady	PCB 标签 0.650x 0.200 英寸
12	R1、R2、 R3、R4、 R5	5	0	电阻, 0, 5% , 0.05W, 0201	CRCW02010000Z0E D	Vishay-Dale	0201
13	R6、R7	2	0	0 Ω 跳线 0.05W , 1/20W 片式电阻器 0201 (公制 0603) 汽车类 AEC-Q200 厚膜	NRC02ZOTRF	NIC Components	0201
14	TP1、 TP2、TP3	3		测试点, 微型, 红 色, TH	5000	Keystone Electronics	红色微型测试点

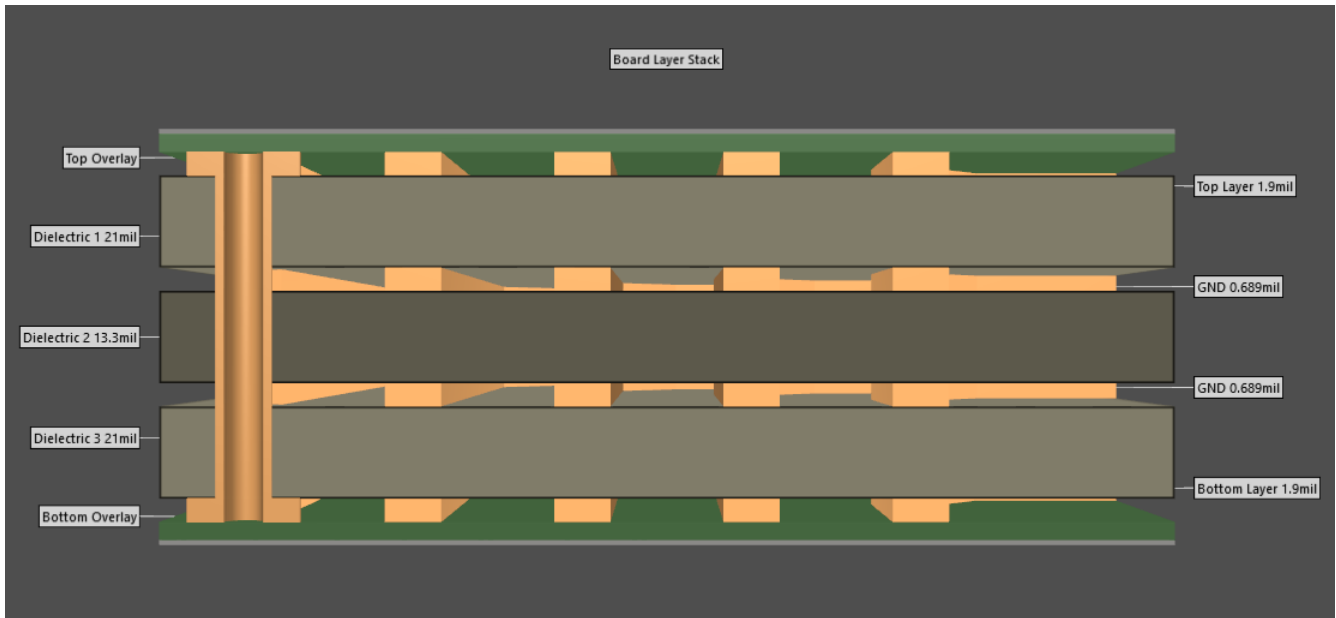
表 3-1. 物料清单 (续)

条目	位号	数量	值	说明	器件型号	制造商	封装参考
15	U1	1		TRF2001P	TRF2001P	德州仪器 (TI)	WQFN-FCRLF28
16	C9	0	1nF	通用片状多层陶瓷电容器, 0201, 1000pF, C0G, 30ppm/°C, 5%, 25V	GRM0335C1E102JA01D	Murata	0201
17	C10、 C11、C12	0	3.3pF	WCAP-CSRFB 多层陶瓷贴片电容器, 高频, 尺寸 0201, NP0 I 类, 3.3pF, 25VDC	885392004007	Würth Elektronik	
18	FID1、 FID2、 FID3	0		基准标记。没有需要购买或安装的元件。	不适用	不适用	不适用

4 其他信息

4.1 商标

所有商标均为其各自所有者的财产。

5 相关文档

如要查看相关文件, 请参阅以下内容:

德州仪器 (TI), [TRF2001P](#) 数据表, 了解详细的器件信息。

STANDARD TERMS FOR EVALUATION MODULES

1. *Delivery:* TI delivers TI evaluation boards, kits, or modules, including any accompanying demonstration software, components, and/or documentation which may be provided together or separately (collectively, an "EVM" or "EVMs") to the User ("User") in accordance with the terms set forth herein. User's acceptance of the EVM is expressly subject to the following terms.
 - 1.1 EVMs are intended solely for product or software developers for use in a research and development setting to facilitate feasibility evaluation, experimentation, or scientific analysis of TI semiconductors products. EVMs have no direct function and are not finished products. EVMs shall not be directly or indirectly assembled as a part or subassembly in any finished product. For clarification, any software or software tools provided with the EVM ("Software") shall not be subject to the terms and conditions set forth herein but rather shall be subject to the applicable terms that accompany such Software
 - 1.2 EVMs are not intended for consumer or household use. EVMs may not be sold, sublicensed, leased, rented, loaned, assigned, or otherwise distributed for commercial purposes by Users, in whole or in part, or used in any finished product or production system.
2. *Limited Warranty and Related Remedies/Disclaimers:*
 - 2.1 These terms do not apply to Software. The warranty, if any, for Software is covered in the applicable Software License Agreement.
 - 2.2 TI warrants that the TI EVM will conform to TI's published specifications for ninety (90) days after the date TI delivers such EVM to User. Notwithstanding the foregoing, TI shall not be liable for a nonconforming EVM if (a) the nonconformity was caused by neglect, misuse or mistreatment by an entity other than TI, including improper installation or testing, or for any EVMs that have been altered or modified in any way by an entity other than TI, (b) the nonconformity resulted from User's design, specifications or instructions for such EVMs or improper system design, or (c) User has not paid on time. Testing and other quality control techniques are used to the extent TI deems necessary. TI does not test all parameters of each EVM. User's claims against TI under this Section 2 are void if User fails to notify TI of any apparent defects in the EVMs within ten (10) business days after delivery, or of any hidden defects with ten (10) business days after the defect has been detected.
 - 2.3 TI's sole liability shall be at its option to repair or replace EVMs that fail to conform to the warranty set forth above, or credit User's account for such EVM. TI's liability under this warranty shall be limited to EVMs that are returned during the warranty period to the address designated by TI and that are determined by TI not to conform to such warranty. If TI elects to repair or replace such EVM, TI shall have a reasonable time to repair such EVM or provide replacements. Repaired EVMs shall be warranted for the remainder of the original warranty period. Replaced EVMs shall be warranted for a new full ninety (90) day warranty period.

WARNING

Evaluation Kits are intended solely for use by technically qualified, professional electronics experts who are familiar with the dangers and application risks associated with handling electrical mechanical components, systems, and subsystems.

User shall operate the Evaluation Kit within TI's recommended guidelines and any applicable legal or environmental requirements as well as reasonable and customary safeguards. Failure to set up and/or operate the Evaluation Kit within TI's recommended guidelines may result in personal injury or death or property damage. Proper set up entails following TI's instructions for electrical ratings of interface circuits such as input, output and electrical loads.

NOTE:

EXPOSURE TO ELECTROSTATIC DISCHARGE (ESD) MAY CAUSE DEGRADATION OR FAILURE OF THE EVALUATION KIT; TI RECOMMENDS STORAGE OF THE EVALUATION KIT IN A PROTECTIVE ESD BAG.

3 Regulatory Notices:

3.1 United States

3.1.1 Notice applicable to EVMs not FCC-Approved:

FCC NOTICE: This kit is designed to allow product developers to evaluate electronic components, circuitry, or software associated with the kit to determine whether to incorporate such items in a finished product and software developers to write software applications for use with the end product. This kit is not a finished product and when assembled may not be resold or otherwise marketed unless all required FCC equipment authorizations are first obtained. Operation is subject to the condition that this product not cause harmful interference to licensed radio stations and that this product accept harmful interference. Unless the assembled kit is designed to operate under part 15, part 18 or part 95 of this chapter, the operator of the kit must operate under the authority of an FCC license holder or must secure an experimental authorization under part 5 of this chapter.

3.1.2 For EVMs annotated as FCC – FEDERAL COMMUNICATIONS COMMISSION Part 15 Compliant:

CAUTION

This device complies with part 15 of the FCC Rules. Operation is subject to the following two conditions: (1) This device may not cause harmful interference, and (2) this device must accept any interference received, including interference that may cause undesired operation.

Changes or modifications not expressly approved by the party responsible for compliance could void the user's authority to operate the equipment.

FCC Interference Statement for Class A EVM devices

NOTE: This equipment has been tested and found to comply with the limits for a Class A digital device, pursuant to part 15 of the FCC Rules. These limits are designed to provide reasonable protection against harmful interference when the equipment is operated in a commercial environment. This equipment generates, uses, and can radiate radio frequency energy and, if not installed and used in accordance with the instruction manual, may cause harmful interference to radio communications. Operation of this equipment in a residential area is likely to cause harmful interference in which case the user will be required to correct the interference at his own expense.

FCC Interference Statement for Class B EVM devices

NOTE: This equipment has been tested and found to comply with the limits for a Class B digital device, pursuant to part 15 of the FCC Rules. These limits are designed to provide reasonable protection against harmful interference in a residential installation. This equipment generates, uses and can radiate radio frequency energy and, if not installed and used in accordance with the instructions, may cause harmful interference to radio communications. However, there is no guarantee that interference will not occur in a particular installation. If this equipment does cause harmful interference to radio or television reception, which can be determined by turning the equipment off and on, the user is encouraged to try to correct the interference by one or more of the following measures:

- Reorient or relocate the receiving antenna.
- Increase the separation between the equipment and receiver.
- Connect the equipment into an outlet on a circuit different from that to which the receiver is connected.
- Consult the dealer or an experienced radio/TV technician for help.

3.2 Canada

3.2.1 For EVMs issued with an Industry Canada Certificate of Conformance to RSS-210 or RSS-247

Concerning EVMs Including Radio Transmitters:

This device complies with Industry Canada license-exempt RSSs. Operation is subject to the following two conditions:

(1) this device may not cause interference, and (2) this device must accept any interference, including interference that may cause undesired operation of the device.

Concernant les EVMs avec appareils radio:

Le présent appareil est conforme aux CNR d'Industrie Canada applicables aux appareils radio exempts de licence. L'exploitation est autorisée aux deux conditions suivantes: (1) l'appareil ne doit pas produire de brouillage, et (2) l'utilisateur de l'appareil doit accepter tout brouillage radioélectrique subi, même si le brouillage est susceptible d'en compromettre le fonctionnement.

Concerning EVMs Including Detachable Antennas:

Under Industry Canada regulations, this radio transmitter may only operate using an antenna of a type and maximum (or lesser) gain approved for the transmitter by Industry Canada. To reduce potential radio interference to other users, the antenna type and its gain should be so chosen that the equivalent isotropically radiated power (e.i.r.p.) is not more than that necessary for successful communication. This radio transmitter has been approved by Industry Canada to operate with the antenna types listed in the user guide with the maximum permissible gain and required antenna impedance for each antenna type indicated. Antenna types not included in this list, having a gain greater than the maximum gain indicated for that type, are strictly prohibited for use with this device.

Concernant les EVMs avec antennes détachables

Conformément à la réglementation d'Industrie Canada, le présent émetteur radio peut fonctionner avec une antenne d'un type et d'un gain maximal (ou inférieur) approuvé pour l'émetteur par Industrie Canada. Dans le but de réduire les risques de brouillage radioélectrique à l'intention des autres utilisateurs, il faut choisir le type d'antenne et son gain de sorte que la puissance isotrope rayonnée équivalente (p.i.r.e.) ne dépasse pas l'intensité nécessaire à l'établissement d'une communication satisfaisante. Le présent émetteur radio a été approuvé par Industrie Canada pour fonctionner avec les types d'antenne énumérés dans le manuel d'usage et ayant un gain admissible maximal et l'impédance requise pour chaque type d'antenne. Les types d'antenne non inclus dans cette liste, ou dont le gain est supérieur au gain maximal indiqué, sont strictement interdits pour l'exploitation de l'émetteur.

3.3 Japan

3.3.1 *Notice for EVMs delivered in Japan:* Please see http://www.tij.co.jp/lstds/ti_ja/general/eStore/notice_01.page 日本国内に輸入される評価用キット、ボードについては、次のところをご覧ください。

<https://www.ti.com/ja-jp/legal/notice-for-evaluation-kits-delivered-in-japan.html>

3.3.2 *Notice for Users of EVMs Considered "Radio Frequency Products" in Japan:* EVMs entering Japan may not be certified by TI as conforming to Technical Regulations of Radio Law of Japan.

If User uses EVMs in Japan, not certified to Technical Regulations of Radio Law of Japan, User is required to follow the instructions set forth by Radio Law of Japan, which includes, but is not limited to, the instructions below with respect to EVMs (which for the avoidance of doubt are stated strictly for convenience and should be verified by User):

1. Use EVMs in a shielded room or any other test facility as defined in the notification #173 issued by Ministry of Internal Affairs and Communications on March 28, 2006, based on Sub-section 1.1 of Article 6 of the Ministry's Rule for Enforcement of Radio Law of Japan,
2. Use EVMs only after User obtains the license of Test Radio Station as provided in Radio Law of Japan with respect to EVMs, or
3. Use of EVMs only after User obtains the Technical Regulations Conformity Certification as provided in Radio Law of Japan with respect to EVMs. Also, do not transfer EVMs, unless User gives the same notice above to the transferee. Please note that if User does not follow the instructions above, User will be subject to penalties of Radio Law of Japan.

【無線電波を送信する製品の開発キットをお使いになる際の注意事項】 開発キットの中には技術基準適合証明を受けていないものがあります。技術適合証明を受けていないものご使用に際しては、電波法遵守のため、以下のいずれかの措置を取っていただく必要がありますのでご注意ください。

1. 電波法施行規則第6条第1項第1号に基づく平成18年3月28日総務省告示第173号で定められた電波暗室等の試験設備でご使用いただく。
2. 実験局の免許を取得後ご使用いただく。
3. 技術基準適合証明を取得後ご使用いただく。

なお、本製品は、上記の「ご使用にあたっての注意」を譲渡先、移転先に通知しない限り、譲渡、移転できないものとします。

上記を遵守頂けない場合は、電波法の罰則が適用される可能性があることをご留意ください。日本テキサス・イ

ンスツルメンツ株式会社

東京都新宿区西新宿 6 丁目 2 4 番 1 号

西新宿三井ビル

3.3.3 *Notice for EVMs for Power Line Communication:* Please see http://www.tij.co.jp/lstds/ti_ja/general/eStore/notice_02.page

電力線搬送波通信についての開発キットをお使いになる際の注意事項については、次のところをご覧ください。 <https://www.ti.com/ja-jp/legal/notice-for-evaluation-kits-for-power-line-communication.html>

3.4 European Union

3.4.1 *For EVMs subject to EU Directive 2014/30/EU (Electromagnetic Compatibility Directive):*

This is a class A product intended for use in environments other than domestic environments that are connected to a low-voltage power-supply network that supplies buildings used for domestic purposes. In a domestic environment this product may cause radio interference in which case the user may be required to take adequate measures.

-
- 4 *EVM Use Restrictions and Warnings:*
 - 4.1 EVMS ARE NOT FOR USE IN FUNCTIONAL SAFETY AND/OR SAFETY CRITICAL EVALUATIONS, INCLUDING BUT NOT LIMITED TO EVALUATIONS OF LIFE SUPPORT APPLICATIONS.
 - 4.2 User must read and apply the user guide and other available documentation provided by TI regarding the EVM prior to handling or using the EVM, including without limitation any warning or restriction notices. The notices contain important safety information related to, for example, temperatures and voltages.
 - 4.3 *Safety-Related Warnings and Restrictions:*
 - 4.3.1 User shall operate the EVM within TI's recommended specifications and environmental considerations stated in the user guide, other available documentation provided by TI, and any other applicable requirements and employ reasonable and customary safeguards. Exceeding the specified performance ratings and specifications (including but not limited to input and output voltage, current, power, and environmental ranges) for the EVM may cause personal injury or death, or property damage. If there are questions concerning performance ratings and specifications, User should contact a TI field representative prior to connecting interface electronics including input power and intended loads. Any loads applied outside of the specified output range may also result in unintended and/or inaccurate operation and/or possible permanent damage to the EVM and/or interface electronics. Please consult the EVM user guide prior to connecting any load to the EVM output. If there is uncertainty as to the load specification, please contact a TI field representative. During normal operation, even with the inputs and outputs kept within the specified allowable ranges, some circuit components may have elevated case temperatures. These components include but are not limited to linear regulators, switching transistors, pass transistors, current sense resistors, and heat sinks, which can be identified using the information in the associated documentation. When working with the EVM, please be aware that the EVM may become very warm.
 - 4.3.2 EVMs are intended solely for use by technically qualified, professional electronics experts who are familiar with the dangers and application risks associated with handling electrical mechanical components, systems, and subsystems. User assumes all responsibility and liability for proper and safe handling and use of the EVM by User or its employees, affiliates, contractors or designees. User assumes all responsibility and liability to ensure that any interfaces (electronic and/or mechanical) between the EVM and any human body are designed with suitable isolation and means to safely limit accessible leakage currents to minimize the risk of electrical shock hazard. User assumes all responsibility and liability for any improper or unsafe handling or use of the EVM by User or its employees, affiliates, contractors or designees.
 - 4.4 User assumes all responsibility and liability to determine whether the EVM is subject to any applicable international, federal, state, or local laws and regulations related to User's handling and use of the EVM and, if applicable, User assumes all responsibility and liability for compliance in all respects with such laws and regulations. User assumes all responsibility and liability for proper disposal and recycling of the EVM consistent with all applicable international, federal, state, and local requirements.
 5. *Accuracy of Information:* To the extent TI provides information on the availability and function of EVMs, TI attempts to be as accurate as possible. However, TI does not warrant the accuracy of EVM descriptions, EVM availability or other information on its websites as accurate, complete, reliable, current, or error-free.
 6. *Disclaimers:*
 - 6.1 EXCEPT AS SET FORTH ABOVE, EVMS AND ANY MATERIALS PROVIDED WITH THE EVM (INCLUDING, BUT NOT LIMITED TO, REFERENCE DESIGNS AND THE DESIGN OF THE EVM ITSELF) ARE PROVIDED "AS IS" AND "WITH ALL FAULTS." TI DISCLAIMS ALL OTHER WARRANTIES, EXPRESS OR IMPLIED, REGARDING SUCH ITEMS, INCLUDING BUT NOT LIMITED TO ANY EPIDEMIC FAILURE WARRANTY OR IMPLIED WARRANTIES OF MERCHANTABILITY OR FITNESS FOR A PARTICULAR PURPOSE OR NON-INFRINGEMENT OF ANY THIRD PARTY PATENTS, COPYRIGHTS, TRADE SECRETS OR OTHER INTELLECTUAL PROPERTY RIGHTS.
 - 6.2 EXCEPT FOR THE LIMITED RIGHT TO USE THE EVM SET FORTH HEREIN, NOTHING IN THESE TERMS SHALL BE CONSTRUED AS GRANTING OR CONFERRING ANY RIGHTS BY LICENSE, PATENT, OR ANY OTHER INDUSTRIAL OR INTELLECTUAL PROPERTY RIGHT OF TI, ITS SUPPLIERS/LICENSORS OR ANY OTHER THIRD PARTY, TO USE THE EVM IN ANY FINISHED END-USER OR READY-TO-USE FINAL PRODUCT, OR FOR ANY INVENTION, DISCOVERY OR IMPROVEMENT, REGARDLESS OF WHEN MADE, CONCEIVED OR ACQUIRED.
 7. *USER'S INDEMNITY OBLIGATIONS AND REPRESENTATIONS.* USER WILL DEFEND, INDEMNIFY AND HOLD TI, ITS LICENSORS AND THEIR REPRESENTATIVES HARMLESS FROM AND AGAINST ANY AND ALL CLAIMS, DAMAGES, LOSSES, EXPENSES, COSTS AND LIABILITIES (COLLECTIVELY, "CLAIMS") ARISING OUT OF OR IN CONNECTION WITH ANY HANDLING OR USE OF THE EVM THAT IS NOT IN ACCORDANCE WITH THESE TERMS. THIS OBLIGATION SHALL APPLY WHETHER CLAIMS ARISE UNDER STATUTE, REGULATION, OR THE LAW OF TORT, CONTRACT OR ANY OTHER LEGAL THEORY, AND EVEN IF THE EVM FAILS TO PERFORM AS DESCRIBED OR EXPECTED.

8. *Limitations on Damages and Liability:*

8.1 *General Limitations.* IN NO EVENT SHALL TI BE LIABLE FOR ANY SPECIAL, COLLATERAL, INDIRECT, PUNITIVE, INCIDENTAL, CONSEQUENTIAL, OR EXEMPLARY DAMAGES IN CONNECTION WITH OR ARISING OUT OF THESE TERMS OR THE USE OF THE EVMS , REGARDLESS OF WHETHER TI HAS BEEN ADVISED OF THE POSSIBILITY OF SUCH DAMAGES. EXCLUDED DAMAGES INCLUDE, BUT ARE NOT LIMITED TO, COST OF REMOVAL OR REINSTALLATION, ANCILLARY COSTS TO THE PROCUREMENT OF SUBSTITUTE GOODS OR SERVICES, RETESTING, OUTSIDE COMPUTER TIME, LABOR COSTS, LOSS OF GOODWILL, LOSS OF PROFITS, LOSS OF SAVINGS, LOSS OF USE, LOSS OF DATA, OR BUSINESS INTERRUPTION. NO CLAIM, SUIT OR ACTION SHALL BE BROUGHT AGAINST TI MORE THAN TWELVE (12) MONTHS AFTER THE EVENT THAT GAVE RISE TO THE CAUSE OF ACTION HAS OCCURRED.

8.2 *Specific Limitations.* IN NO EVENT SHALL TI'S AGGREGATE LIABILITY FROM ANY USE OF AN EVM PROVIDED HEREUNDER, INCLUDING FROM ANY WARRANTY, INDEMNITY OR OTHER OBLIGATION ARISING OUT OF OR IN CONNECTION WITH THESE TERMS, , EXCEED THE TOTAL AMOUNT PAID TO TI BY USER FOR THE PARTICULAR EVM(S) AT ISSUE DURING THE PRIOR TWELVE (12) MONTHS WITH RESPECT TO WHICH LOSSES OR DAMAGES ARE CLAIMED. THE EXISTENCE OF MORE THAN ONE CLAIM SHALL NOT ENLARGE OR EXTEND THIS LIMIT.

9. *Return Policy.* Except as otherwise provided, TI does not offer any refunds, returns, or exchanges. Furthermore, no return of EVM(s) will be accepted if the package has been opened and no return of the EVM(s) will be accepted if they are damaged or otherwise not in a resalable condition. If User feels it has been incorrectly charged for the EVM(s) it ordered or that delivery violates the applicable order, User should contact TI. All refunds will be made in full within thirty (30) working days from the return of the components(s), excluding any postage or packaging costs.

10. *Governing Law:* These terms and conditions shall be governed by and interpreted in accordance with the laws of the State of Texas, without reference to conflict-of-laws principles. User agrees that non-exclusive jurisdiction for any dispute arising out of or relating to these terms and conditions lies within courts located in the State of Texas and consents to venue in Dallas County, Texas. Notwithstanding the foregoing, any judgment may be enforced in any United States or foreign court, and TI may seek injunctive relief in any United States or foreign court.

Mailing Address: Texas Instruments, Post Office Box 655303, Dallas, Texas 75265
Copyright © 2023, Texas Instruments Incorporated

重要通知和免责声明

TI“按原样”提供技术和可靠性数据（包括数据表）、设计资源（包括参考设计）、应用或其他设计建议、网络工具、安全信息和其他资源，不保证没有瑕疵且不做任何明示或暗示的担保，包括但不限于对适销性、与某特定用途的适用性或不侵犯任何第三方知识产权的暗示担保。

这些资源可供使用 TI 产品进行设计的熟练开发人员使用。您将自行承担以下全部责任：(1) 针对您的应用选择合适的 TI 产品，(2) 设计、验证并测试您的应用，(3) 确保您的应用满足相应标准以及任何其他安全、安保法规或其他要求。

这些资源如有变更，恕不另行通知。TI 授权您仅可将这些资源用于研发本资源所述的 TI 产品的相关应用。严禁以其他方式对这些资源进行复制或展示。您无权使用任何其他 TI 知识产权或任何第三方知识产权。对于因您对这些资源的使用而对 TI 及其代表造成的任何索赔、损害、成本、损失和债务，您将全额赔偿，TI 对此概不负责。

TI 提供的产品受 [TI 销售条款](#)、[TI 通用质量指南](#) 或 [ti.com](#) 上其他适用条款或 TI 产品随附的其他适用条款的约束。TI 提供这些资源并不会扩展或以其他方式更改 TI 针对 TI 产品发布的适用的担保或担保免责声明。除非德州仪器 (TI) 明确将某产品指定为定制产品或客户特定产品，否则其产品均为按确定价格收入目录的标准通用器件。

TI 反对并拒绝您可能提出的任何其他或不同的条款。

版权所有 © 2026，德州仪器 (TI) 公司

最后更新日期：2025 年 10 月