

# EVM User's Guide: DAC8N-DGK-EVM

## DAC8N-DGK-EVM



### 说明

DAC8N-DGK-EVM 是一个易于使用的平台，用于评估 DAC8N 系列器件的功能和性能。DAC8N-DGK-EVM 支持采用 DGK 封装的器件。DAC8N-DGK-EVM 具有可选电路和跳线，可针对不同的应用配置器件。此 EVM 安装了 FT4232，便于在 EVM 和 GUI 之间轻松进行 SPI 和 I<sup>2</sup>C 通信。DAC8N041 安装在 EVM 上。

### 开始使用

1. 订购 [EVM](#)。
2. 配置 EVM 跳线。
3. 从资源文件夹安装 DAC8N GUI。
4. 连接 USB 和外部电源。
5. 启动 DAC8N GUI。

### 特性

- 用于评估采用 DGK 封装的 DAC8N 器件的可配置电路
- 通过 USB 提供板载 VDD ( 5V、3.3V 和 1.8V ) 支持
- 板载 2.5V 基准
- 使用板载 FT4232，可利用 DAC8N GUI 轻松写入 DAC
- 提供外部 SPI 和 I<sup>2</sup>C 连接

### 应用

- 过程控制
- [数据采集系统](#)
- [闭环伺服控制](#)
- [PC 外设](#)
- [便携式仪器](#)

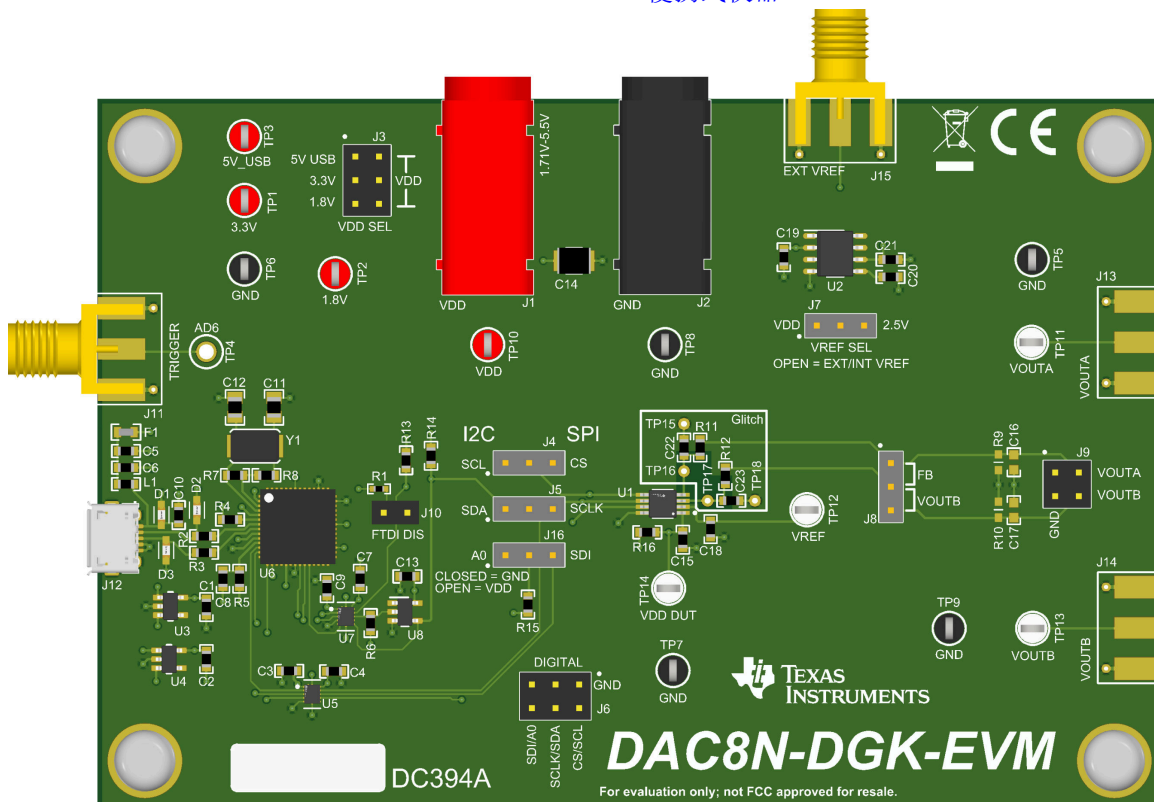

DAC8N-DGK-EVM 电路板

## 1 评估模块概述

### 1.1 简介

本用户指南介绍了 DAC8N-DGK-EVM 的特性、操作和推荐用例，提供了有关如何使用 DAC8N-DGK-EVM 电路板和所含软件的示例和说明。本文档中的评估板、评估模块和 EVM 等术语指的是 DAC8N-DGK-EVM。本文档还包含原理图、参考印刷电路板 (PCB) 布局和完整的物料清单 (BOM)。

DAC8N-DGK-EVM 使用 EVM 随附的 USB 电缆连接到个人电脑 (PC)。该评估板具有适用于所有通信线路、DAC 输出和电源的连接器和测试点。图 1-1 展示了 DAC8N-DGK-EVM 的方框图。



图 1-1. 工作原理方框图

### 1.2 套件内容

表 1-1 详细说明了 EVM 套件的内容。如果缺少任何元件，请通过 (972) 644-5580 联系 TI 产品信息中心。在 TI 网站 [www.ti.com](http://www.ti.com) 上下载相关软件的最新版本。

表 1-1. DAC8N-DGK-EVM 套件内容

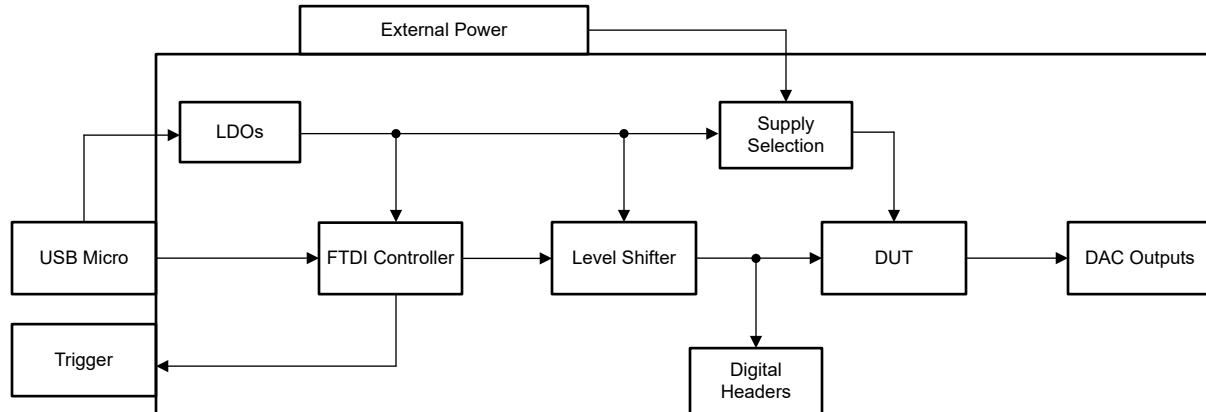
条目	数量
DAC8N-DGK-EVM PCB 评估板	1
USB-A 转 Micro-USB 电缆	1

### 1.3 规格

此 EVM 旨在对该器件的基本功能进行评估，此布局并非作为目标电路的模型使用，也不针对电磁兼容性 (EMC) 测试进行设计。此 EVM 包含一个安装了 DAC8N041 的印刷电路板 (PCB)。

### 1.4 器件信息

DAC8N 是一个与软件兼容的电压输出数模转换器 (DAC) 系列。该系列器件以 16 位、14 位、12 位、10 位和 8 位分辨率提供单、双、四和八通道。这些器件支持 Hi-Z 和有限阻抗断电模式。这些 DAC 具有超低干扰和超低功耗。这些器件会自动检测 I<sup>2</sup>C 和 SPI。

凭借这组功能以及微型封装和超低功耗，这些 DAC 非常适合工业自动化和控制、医疗设备和个人电子产品等应用。

以下器件与 DAC8N-DGK-EVM 兼容。

- DAC8N001
- DAC8N002
- DAC8N041
- DAC8N042
- DAC6N031
- DAC6N032

## 2 硬件

### 2.1 电源要求

DAC8N-DGK-EVM 需要一个电源轨 VDD。USB 连接为 EVM 提供 5V 的电源。稳压器从 USB 5V 电源生成 3.3V 和 1.8V 电压。这些 3.3V 和 1.8V 电源用于为 FT4232 控制器供电。

要将板载 5V、3.3V 或 1.8V 电源用作 DAC8N-DGK-EVM VDD 电源，请短接跳线 J3。默认情况下，VDD 连接到板载 5V 电源。或者，VDD 可由香蕉插孔 J1 从外部供电。在将外部电源连接到 VDD 之前，请移除 J3 上的跳线连接器。

要将 DAC8N-DGK-EVM VREF 连接到板载 2.5V 或 VDD，请短接跳线 J7。默认情况下，VREF 连接到 VDD 电源。或者，VREF 可通过 SMA J15 从外部供电。在将外部电源连接到 VREF 之前，请移除 J7 上的跳线连接器。如果 DUT 具有内部基准，请在启用该基准之前移除跳线和外部电压。

### 2.2 接头信息

表 2-1 定义了 DAC8N-DGK-EVM 输出接头 J9。

表 2-1. 输出接头 J9

引脚	定义
2	VOUTA
4	VOUTB
1、3	GND

表 2-2 定义了 DAC8N-DGK-EVM 数字接头 J6。

表 2-2. 数字接头 J6

引脚	定义
2	CS/SCL
4	SCLK/SDA
6	SDI/A0
1、3、5	GND

表 2-3 展示了 DAC8N-DGK-EVM 的连接器定义。

表 2-3. 连接器定义

位号	定义
J1	DAC8N VDD 电源 ( 1.7V 至 5.5V )
J2	DAC8N 地
J11	用于 FT4232 触发器输出的 SMA 连接器
J12	USB 连接器
J13	用于 DAC8N VOUTA 的 SMA 连接器 ( 未组装 )
J14	用于 DAC8N VOUTB 的 SMA 连接器 ( 未组装 )
J15	DAC8N 外部基准

### 2.3 跳线信息

表 2-4 显示了 DAC8N-DGK-EVM 跳线定义。图 2-1 显示了电路板上的默认跳线连接。

表 2-4. 跳线定义

位号	PCB 说明	位置
J3	VDD SEL	短接 1-2 : VDD 连接至 5V USB 电源 (默认) 短接 3-4 : VDD 连接至 3.3V 稳压器 短接 5-6 : VDD 连接至 1.8V 稳压器 开路 : VDD 不由板载电源供电。
J4	SCL - CS	短接 1-2 : 该 EVM 配置为 I <sup>2</sup> C 短接 2-3 : 该 EVM 配置为 SPI (默认)
J5	SDA - SCLK	短接 1-2 : 该 EVM 配置为 I <sup>2</sup> C 短接 2-3 : 该 EVM 配置为 SPI (默认)
J7	VREF SEL	短接 1-2 : DUT VREF 连接至 VDD (默认) 短接 2-3 : DUT VREF 连接至板载 2.5V 开路 : DUT VREF 连接至板载电源。可以使用外部基准
J8	VOUTB - FB	短接 1-2 : DUT 的第三个引脚连接至 VOUTA 并用作反馈引脚。 短接 2-3 : DUT 的第三个引脚用作 VOUTB。
J10	FTDI DIS	短路 : 断开 DAC8N 与 FTDI 驱动器的连接。 开路 : FTDI 驱动程序连接到 DAC8N (默认)。
J16	GND - SDI	短接 1-2 : 该 EVM 配置为 I <sup>2</sup> C, 其中 A0 接地 短接 2-3 : 该 EVM 配置为 SPI (默认) 开路 : 该 EVM 配置为 I <sup>2</sup> C, 其中 A0 连接至 VDD。有关 I <sup>2</sup> C 地址配置, 请参阅表 2-5



图 2-1. DAC8N-DGK-EVM 默认跳线设置

## 2.4 接口

DAC8N-DGK-EVM 使用 FT4232 控制器来连接 DAC8N 和 EVM GUI。要将 EVM 板上的 FT4232 数字控制器连接到计算机，请将 USB 连接器与 J12 连接器对齐并连接牢固。验证连接是否紧密；连接松动可能会导致运行时断断续续。100mil 接头 (J6) 用于外部通信。表 2-2 列出了 J6 引脚定义。要使用外部通信，请闭合跳线 J10 以禁用与 FT4232 控制器的连接。

### 2.4.1 SPI 配置

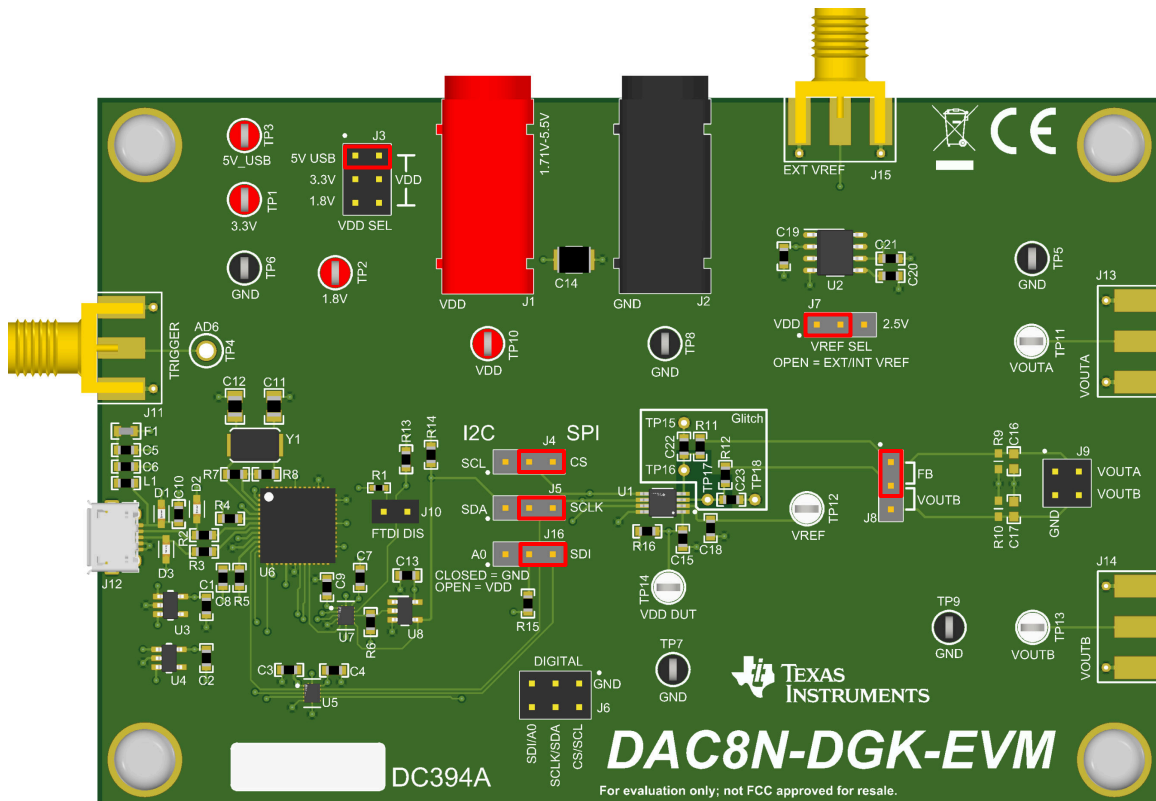
图 2-2 展示了配置用于 SPI 通信的 DAC8N-DGK-EVM。



图 2-2. SPI 跳线配置

## 2.4.2 I<sup>2</sup>C 配置

图 2-3 展示了配置用于 I<sup>2</sup>C 通信的 DAC8N-DGK-EVM。

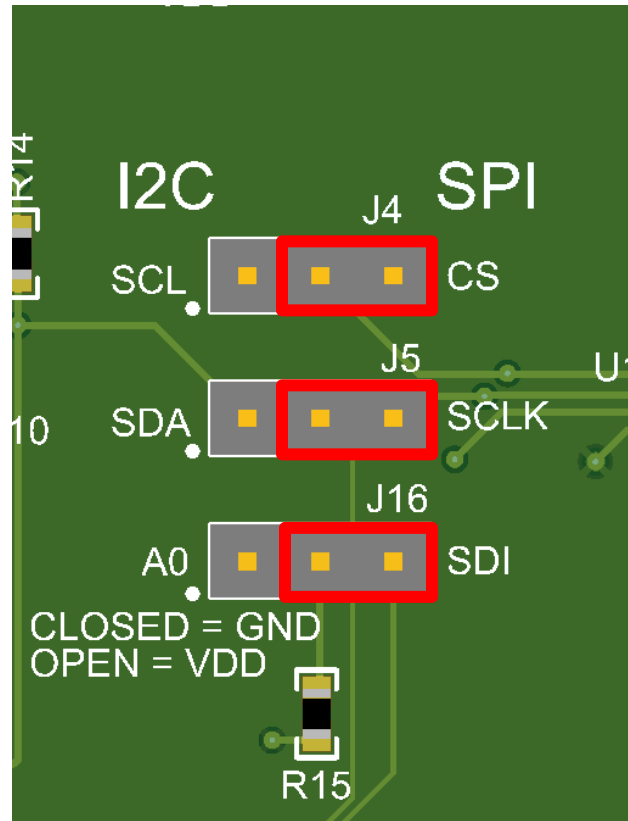

图 2-3. I<sup>2</sup>C 跳线配置

J16 上的跳线连接确定了器件的地址。表 2-5 显示了两种可能的跳线配置和相应的器件地址。

表 2-5. I<sup>2</sup>C 地址配置

跳线	A0	[A6:A0]
跳线 CLOSED	GND	100 1100
跳线 OPEN	VDD	100 1110

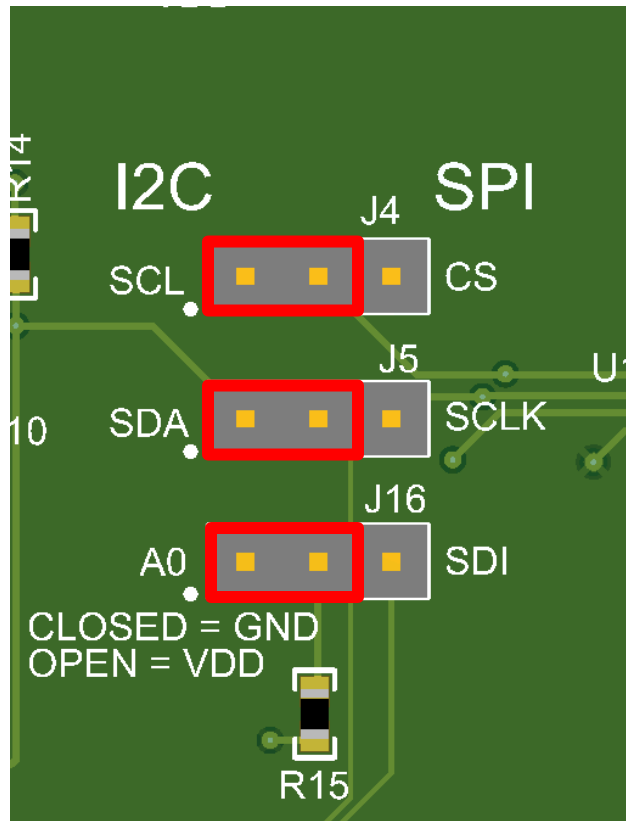
## 2.5 测试点

表 2-6 定义了 DAC8N-DGK-EVM 测试点。

**表 2-6. 测试点定义**

位号	网	定义
TP1	3.3V	板载 3.3V 电源
TP2	1.8V	板载 1.8V 电源
TP3	USB_5V	USB 5V 电源
TP4	FTDI_TRIGGER	从 FTDI 触发 (未组装)
TP5、TP6、 TP7、TP8、 TP9	GND	接地测试点
TP10	VDD	VDD
TP11	VOUTA	VOUTA
TP12	VREF	VREF
TP13	VOUTB	VOUTB
TP14	VDD DUT	专用 DUT VDD 测试点
TP15、TP16	VOUTA 干扰	VOUTA 的隔离式干扰测试点。 TP15 接地，TP16 为 VOUTA
TP17、TP18	VOUTB 干扰	VOUTB 的隔离式干扰测试点。 TP18 接地，TP17 为 VOUTB

## 2.6 额外功能

### 2.6.1 功耗测试

许多 DAC8N 器件具有低功耗特性。默认情况下，通信电压电平移位器和板载 2.5V 基准依靠 VDD 电压运行。DAC8N-DGK-EVM 能够隔离 DUT VDD 以测试功耗。要隔离 DUT，需要移除 R16 并向 TP14 和接地测试点施加 VDD 电源。照常通过 J3 或 J1 为电路板供电，从而为电路板的其余部分供电。

### 2.6.2 干扰测试

DAC8N 器件具有极低的干扰。DAC8N-DGK-EVM 具有专用测试点，用于测试 VOUTA 和 VOUTB 输出上的干扰。图 2-4 展示了电路。

要测试 VOUTA 上的干扰，需要移除 R11 并为 C22 组装低容值电容器。TP16 和布线与 EVM 电源平面和接地平面完全隔离。

要测试 VOUTB 上的干扰，需要移除 R12 并为 C23 组装低容值电容器。TP17 和布线与 EVM 电源平面和接地平面完全隔离。



图 2-4. DAC8N GUI 干扰电路

### 3 软件

#### 3.1 软件安装

从 TI.com 上的 DAC8N-DGK-EVM 工具页面下载最新版本的 EVM GUI 安装程序。运行安装程序以安装软件，并将所需的 LabVIEW™ 软件文件和驱动程序复制到 PC。

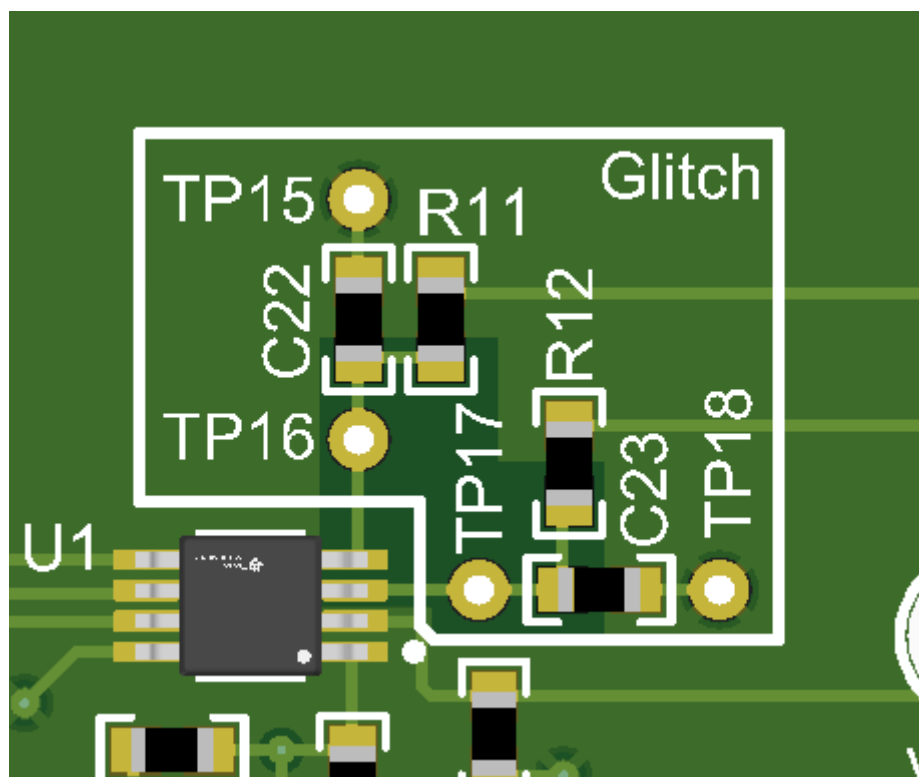
启动安装程序后，会出现一个对话框窗口，供您选择安装目录。如果保持不变，安装位置默认为 *C:\Program Files (x86)\Texas Instruments\DAC8N GUI*。图 3-1 展示了默认路径。



图 3-1. 软件安装路径

该 EVM 软件还使用单独的可执行文件来安装 Future Technology Devices International Limited (FTDI) USB 驱动程序。图 3-2 显示了在完成 DAC8N-DGK-EVM 软件安装之后自动启动的 FTDI USB 驱动程序安装窗口。

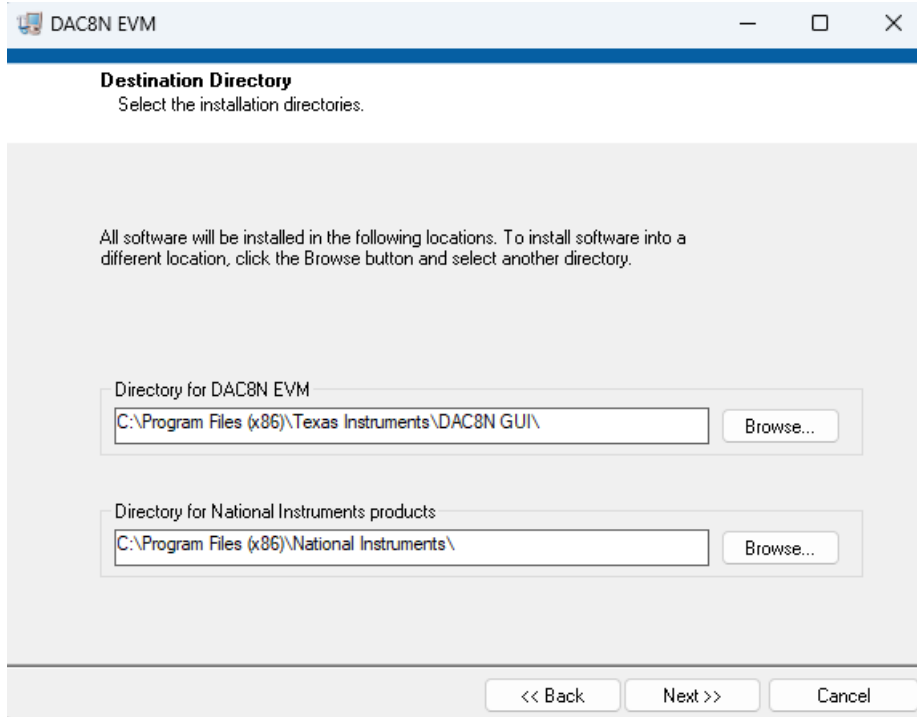

图 3-2. FTDI USB 驱动程序

### 3.2 软件说明

使用 DAC8N GUI 可轻松实现与器件的 I<sup>2</sup>C 或 SPI 通信。虽然整个寄存器映射可供用户使用，但为了便于操作，某些特性已抽象到 *高层配置* 页面中的用户控件。

#### 3.2.1 启动软件

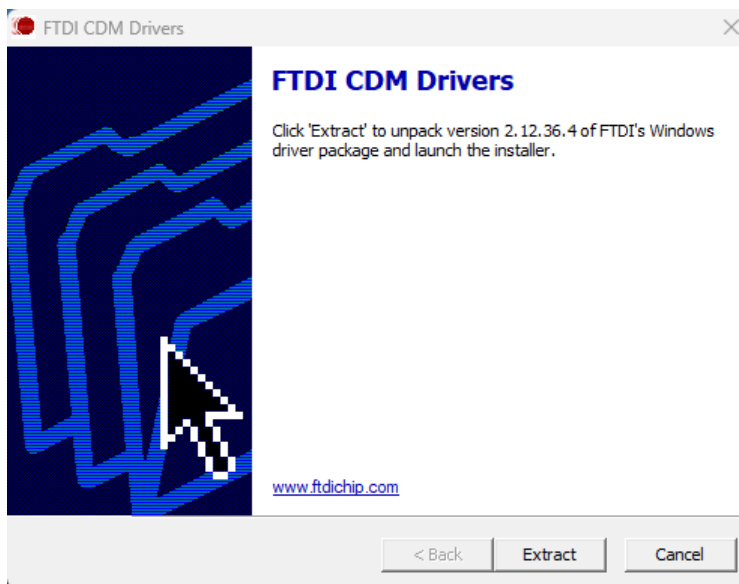
通过在 Windows® 开始菜单中搜索 DAC8N GUI 来启动该软件。

启动该 GUI 时，图 3-3 会显示 *DAC8N Channel Selection* 菜单。DAC8N-DGK-EVM 支持单通道和双通道器件。选择器件具有的输出通道数，然后单击 *CONFIG*。



图 3-3. DAC8N 通道选择

图 3-4 显示了启动后的 GUI。如果软件启动时 FTDI 控制器未连接到 PC，则 GUI 默认为 *演示模式*。GUI 的左下角显示硬件连接状态，即“DEMO MODE”或“CONNECTED”，如图 3-5 所示。将 FTDI 控制器正确连接到 PC 后，取消选中右上方的 *Demo Mode* 框以初始化 GUI。



图 3-4. 启动时的 DAC8N GUI

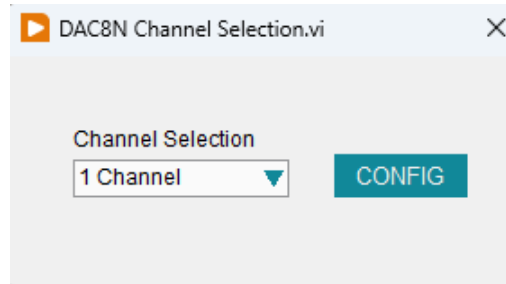

图 3-5. FTDI 数字控制器连接状态

取消选中 *Demo Mode* 框后，会弹出 *Interface Configuration* 菜单。图 3-6 显示了该菜单。接口菜单配置 SPI 或 I<sup>2</sup>C 速度和 I<sup>2</sup>C 器件地址。

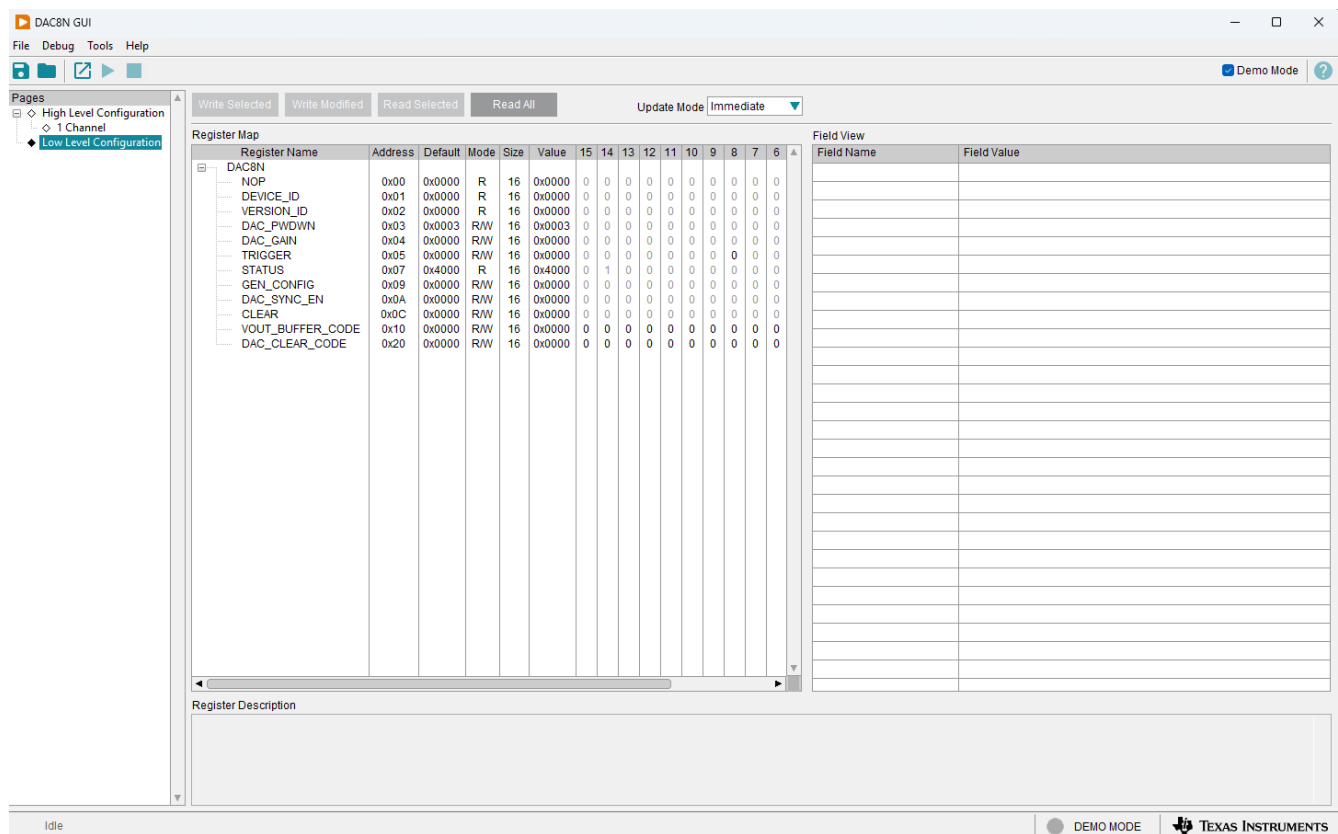

图 3-6. DAC8N 配置菜单

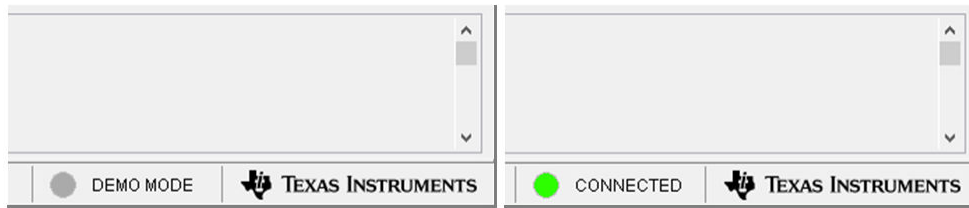
### 3.2.2 底层配置页面

DAC8N GUI 寄存器映射根据启动时所选的通道数而有所不同。图 3-7 展示了该 GUI 的 *1 Channel Low Level Configuration* 页面。图 3-8 展示了该 GUI 的 *2 Channel Low Level Configuration* 页面。可通过此页面直接访问该器件上的所有寄存器。

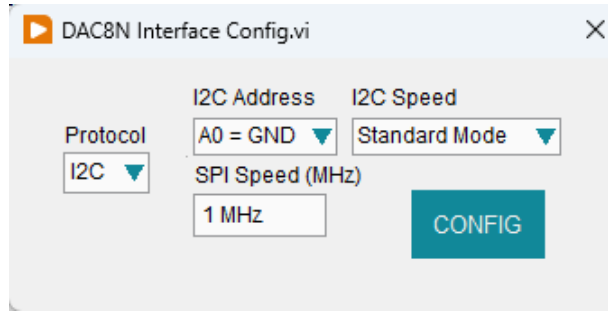

图 3-7. DAC8N GUI 1 Channel Low Level Configuration 页面



图 3-8. DAC8N GUI 2 Channel Low Level Configuration 页面

页面中央的 *Register Map* 部分列出了该器件的所有寄存器。*Register Map* 部分正上方有四个按钮，可用于对所有寄存器进行读写访问。

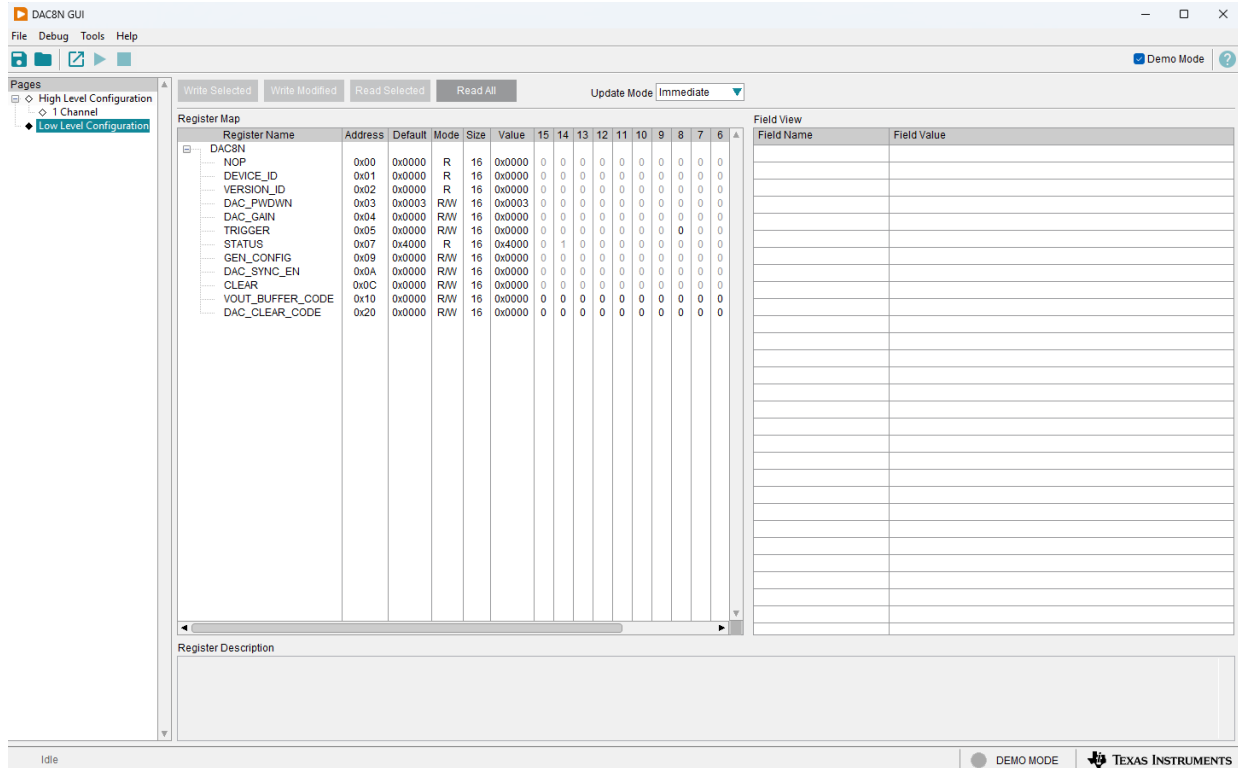
该页面右侧的 *Field View* 部分显示了当前所选寄存器中的各种字段。选择一个字段以突出显示器件数据表中所述的每个字段。通过在寄存器映射的 *Value* 列中输入十六进制值，即可将数据写入寄存器。要将各个位设置为 1 和 0，请点击它们。

### 3.2.3 High Level Configuration 页面

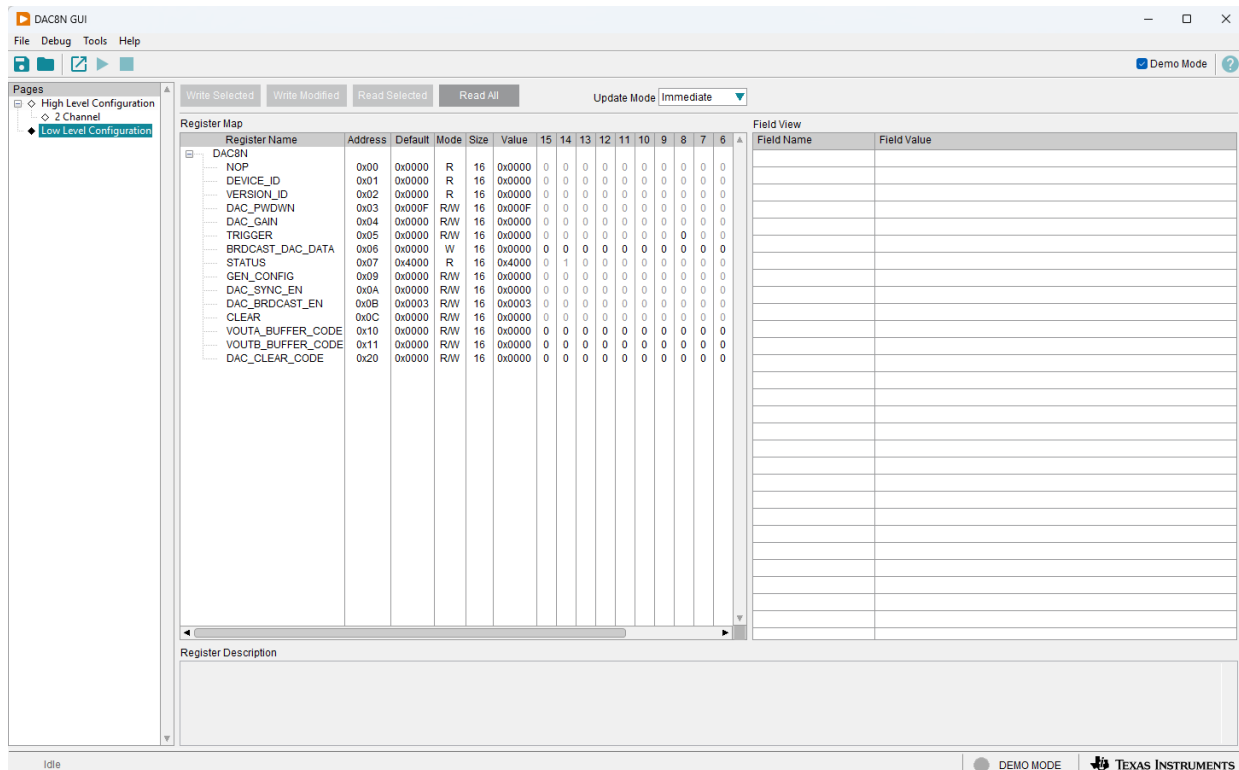
通过 *High Level Configuration* 页面，可轻松写入各种器件寄存器。DAC8N GUI *High Level Configuration* 页面根据启动时选择的通道数而有所不同。图 3-9 显示了 DAC8N GUI 的 *1 Channel High Level Configuration* 页面。图 3-10 显示了 DAC8N GUI 的 *2 Channel High Level Configuration* 页面。



图 3-9. DAC8N GUI 1 Channel High Level Configuration 页面



图 3-10. DAC8N GUI 2 Channel High Level Configuration 页面

## 4 硬件设计文件

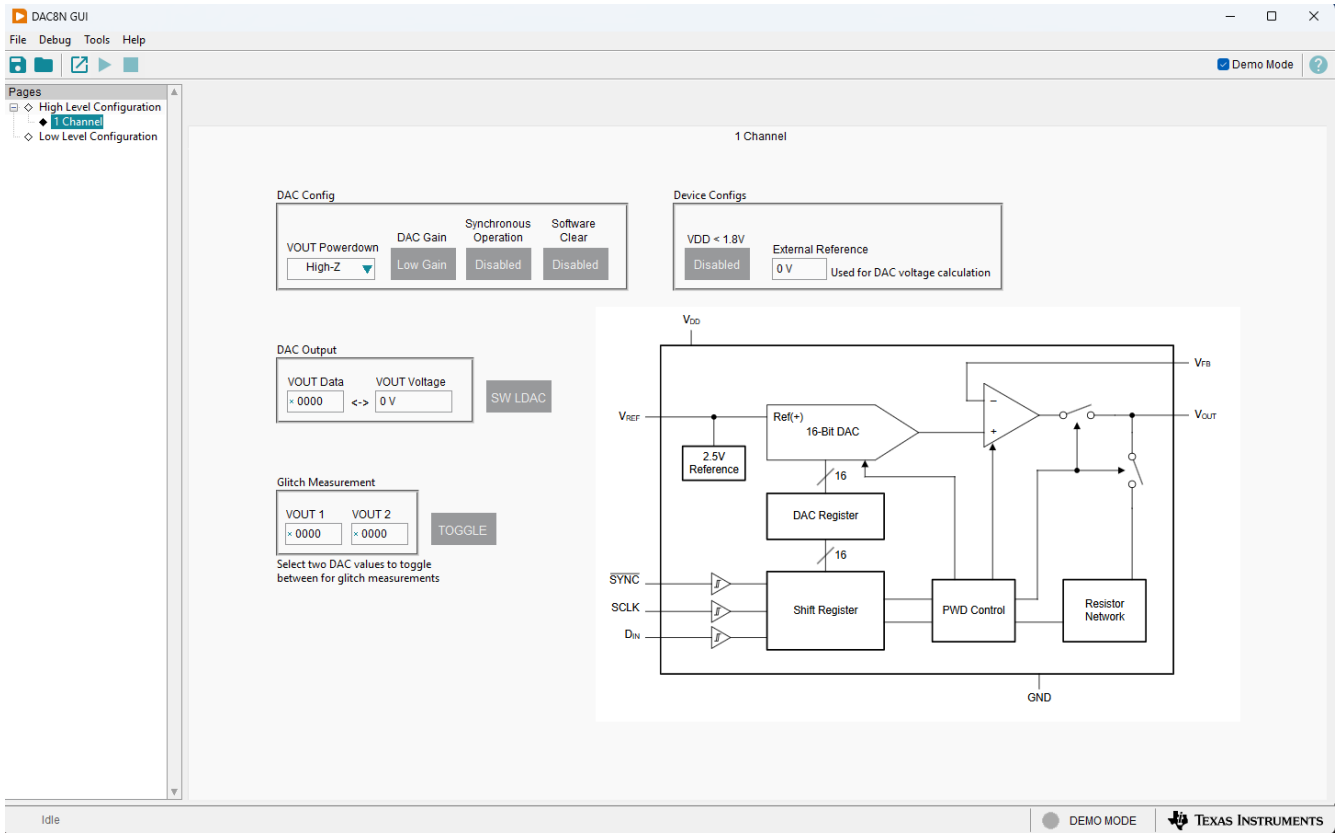
### 4.1 原理图

图 4-1 和图 4-2 显示了 DAC8N-DGK-EVM 原理图。

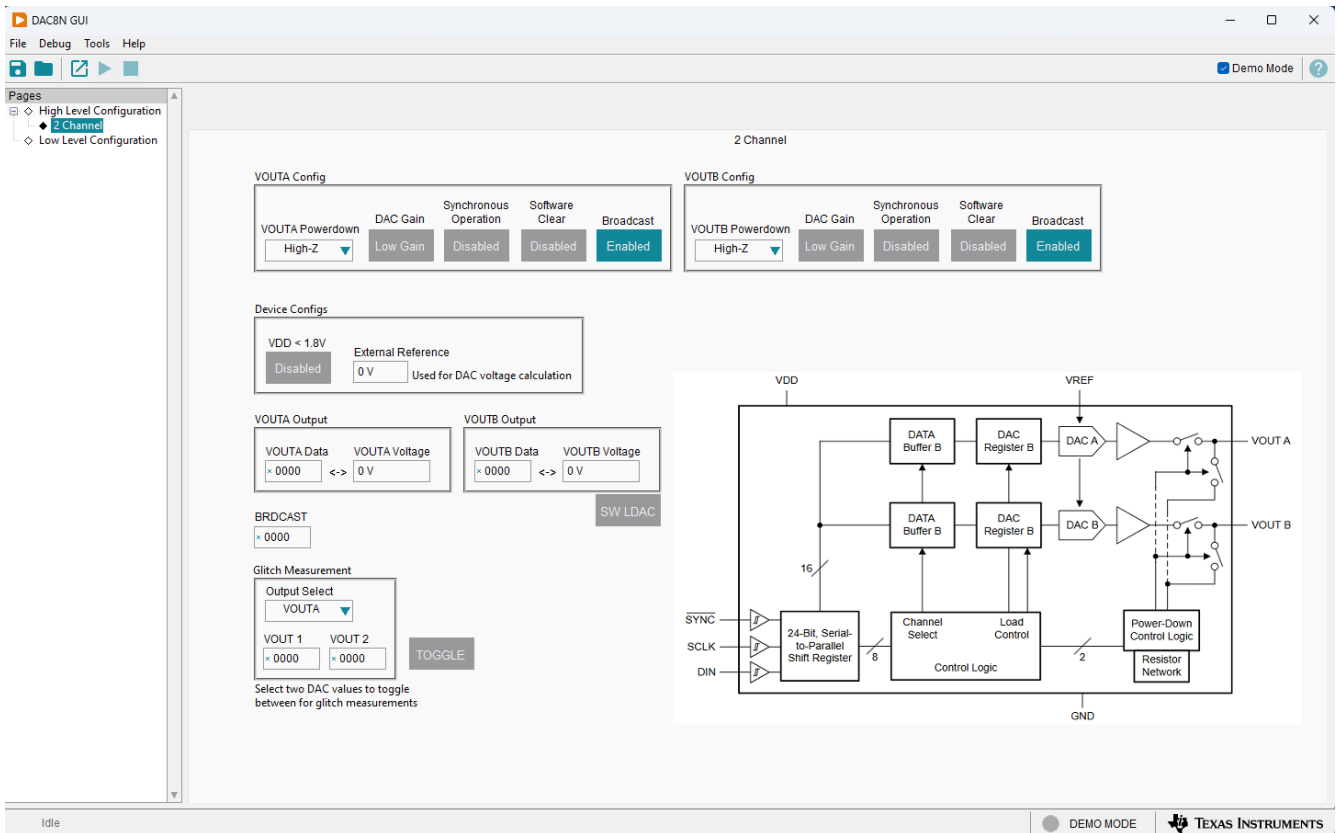

图 4-1. DAC8N-DGK-EVM DUT 原理图



图 4-2. DAC8N-DGK-EVM FTDI 接口原理图

## 4.2 PCB 布局

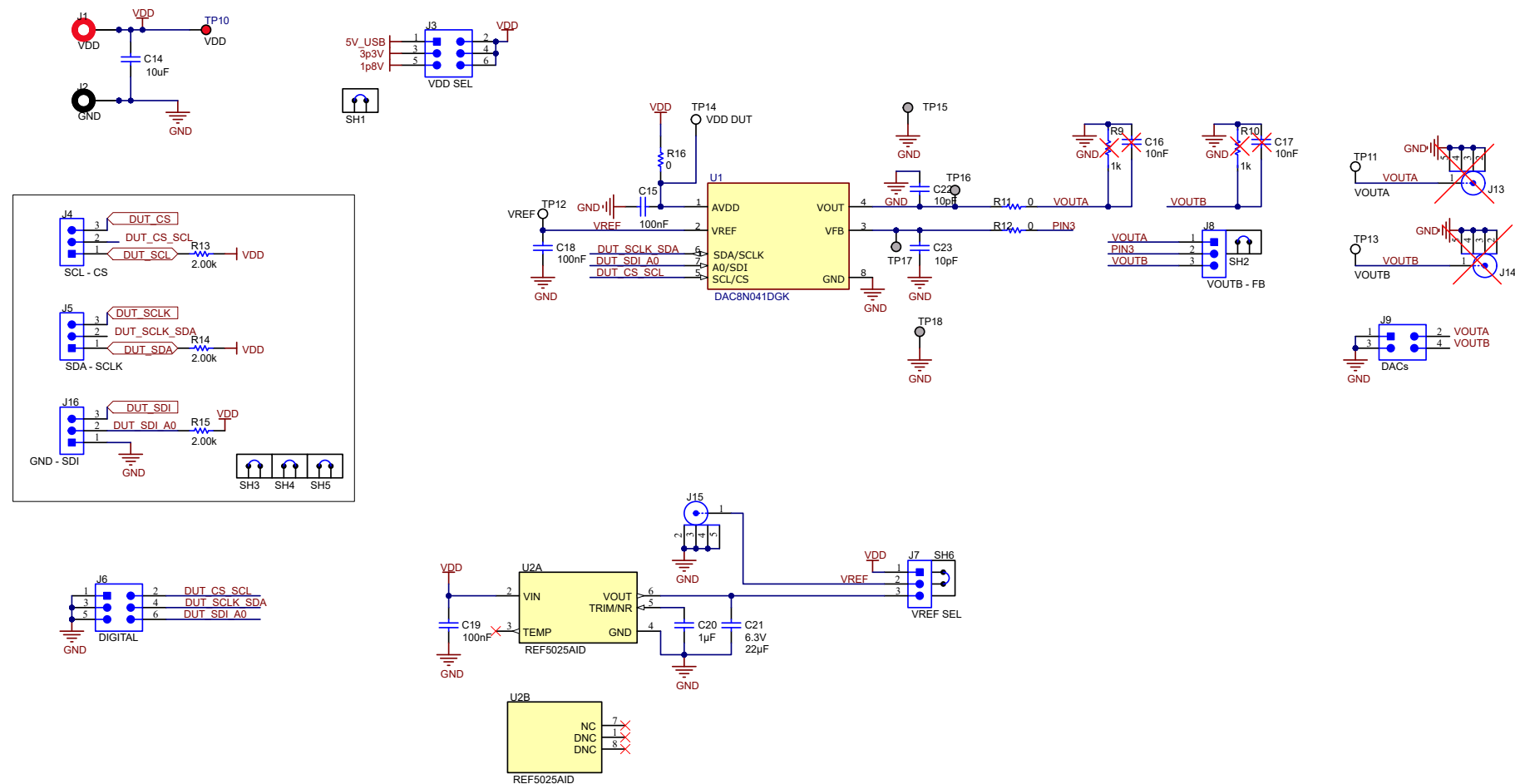
图 4-3 至 图 4-6 显示了 DAC8N-DGK-EVM 电路板布局。

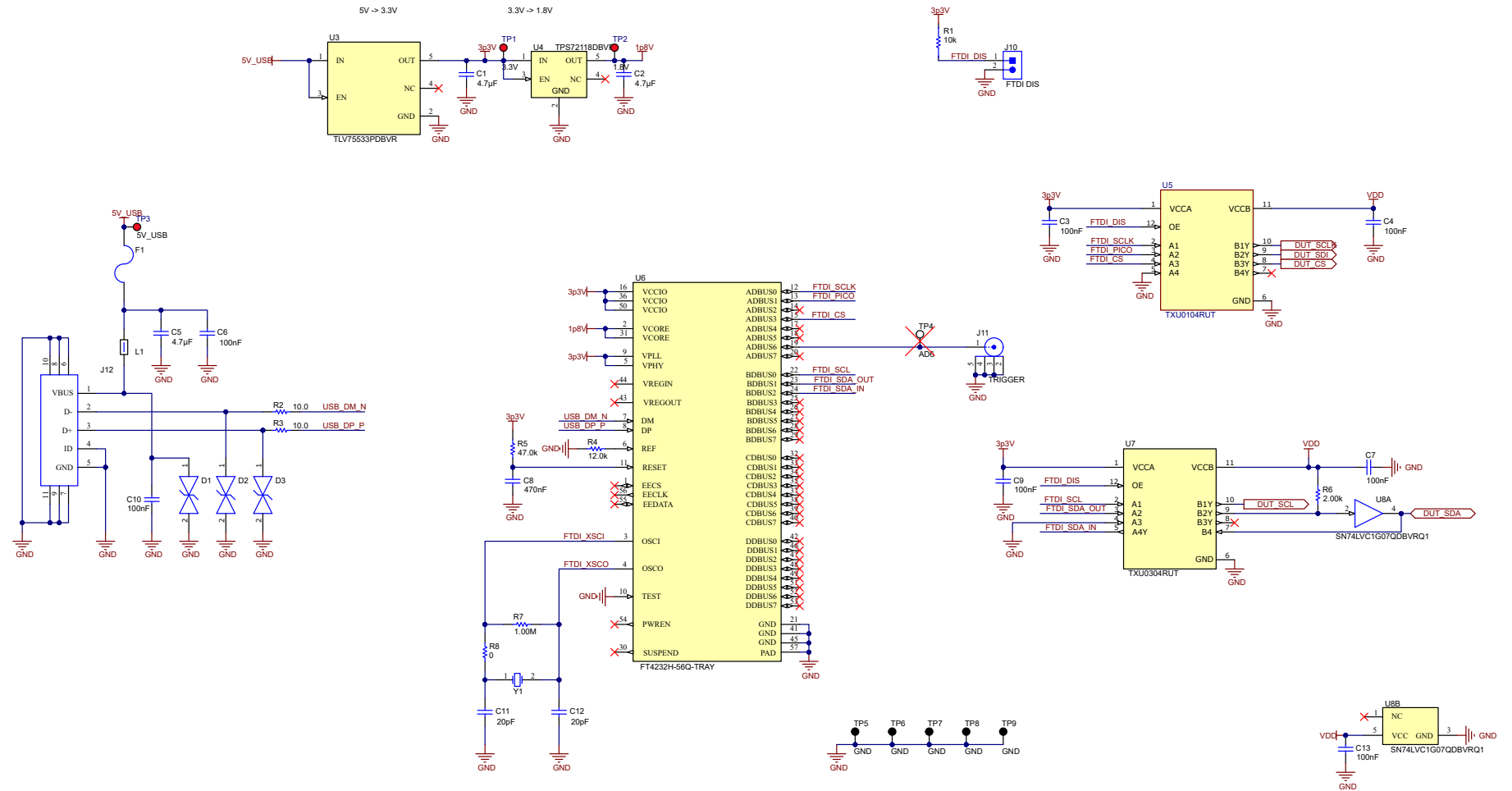

图 4-3. DAC8N-DGK-EVM PCB 顶层布局



图 4-4. DAC8N-DGK-EVM PCB 中层 1 布局 ( 接地平面 )

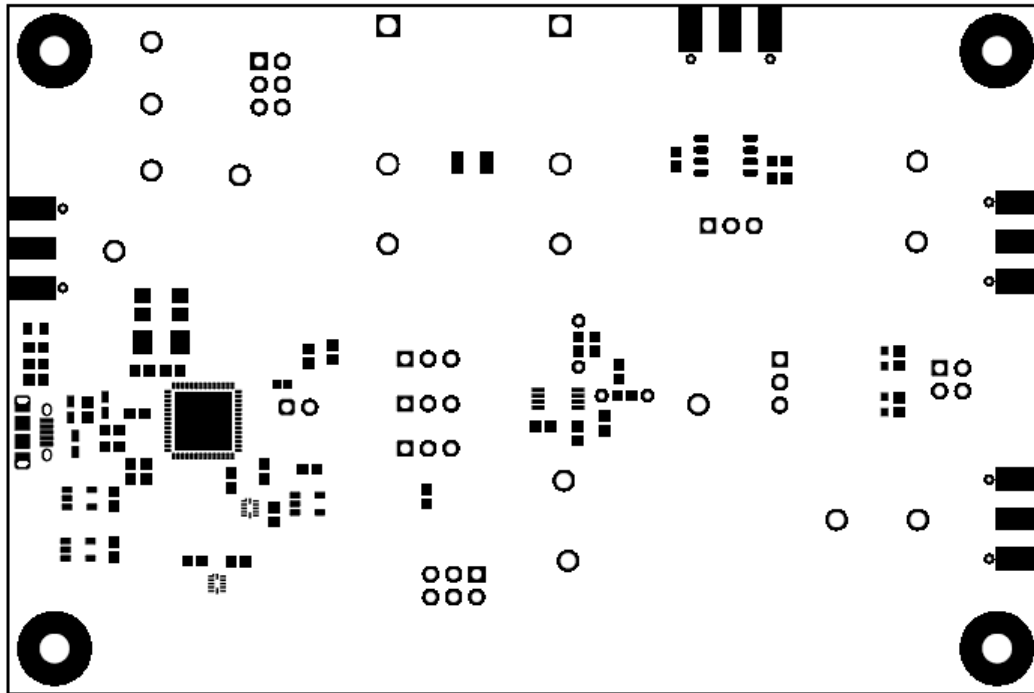

图 4-5. DAC8N-DGK-EVM PCB 中层 2 布局 (电源平面)

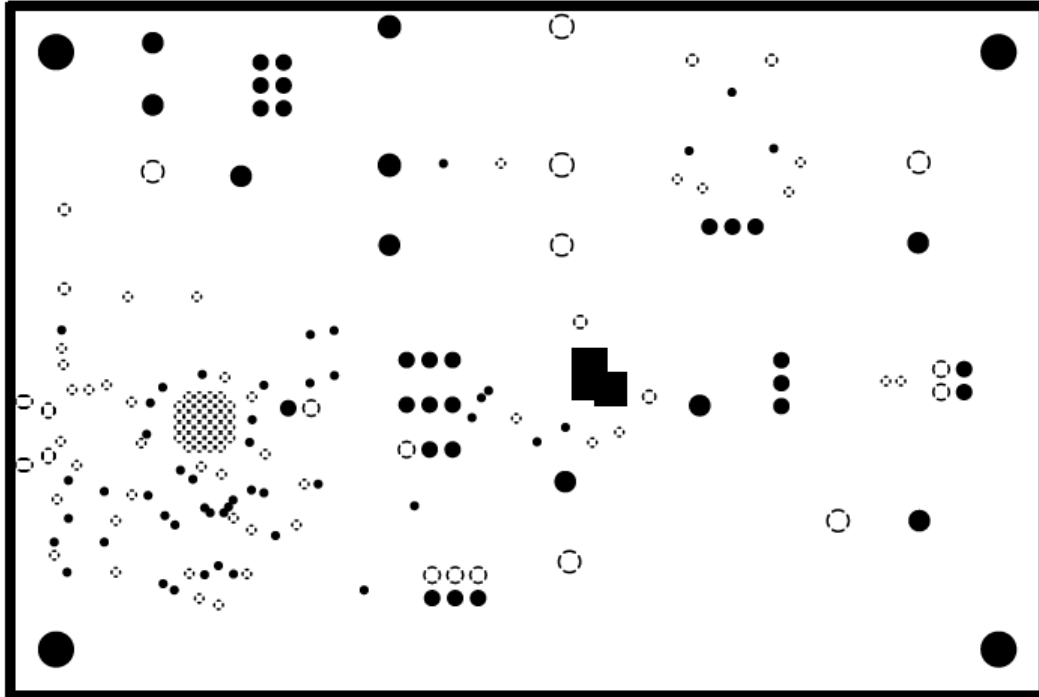

图 4-6. DAC8N-DGK-EVM PCB 底层布局

### 4.3 物料清单 (BOM)

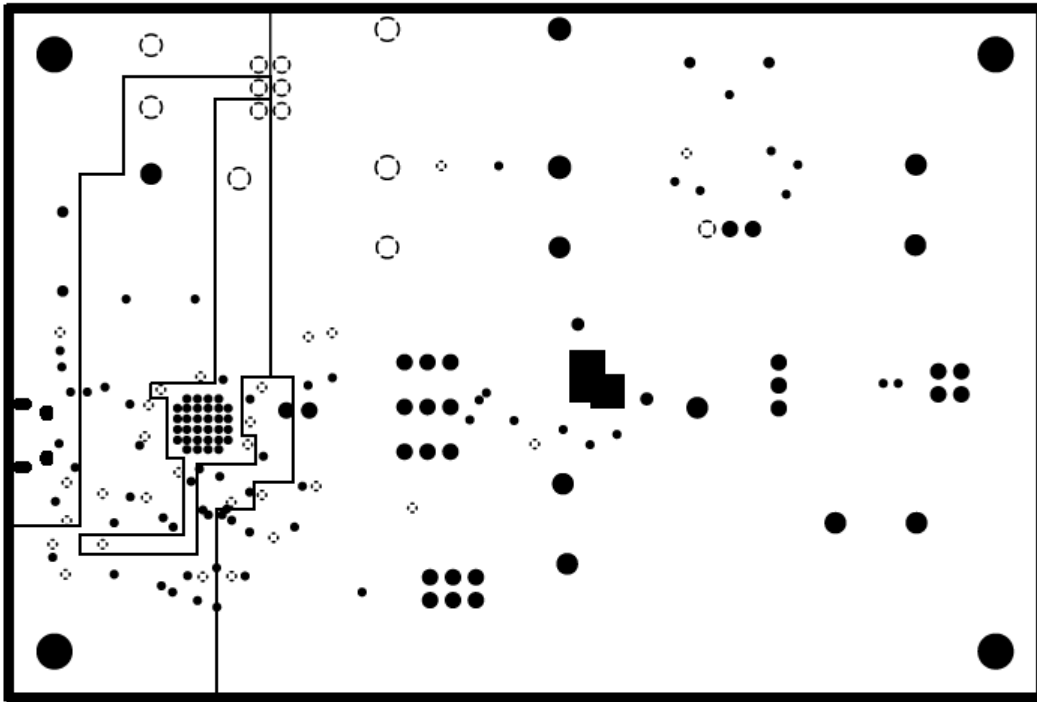
**表 4-1. BOM**

位号	数量	值	说明	封装参考	器件型号	制造商
C1、C2、C5	3	4.7 $\mu$ F	电容, 陶瓷, 4.7 $\mu$ F, 16V, +/-10%, X7R, 0603	0603	GRM188Z71C475KE21D	MuRata
C3、C4、C6、C7、 C9、C10、C13、C15、 C18、C19	10	0.1 $\mu$ F	电容, 陶瓷, 0.1 $\mu$ F, 50V, +/-10%, X7R, AEC-Q200 0 级, 0603	0603	06035C104K4Z4A	AVX
C8	1	0.47 $\mu$ F	电容, 陶瓷, 0.47 $\mu$ F, 25V, +/-10%, X7R, 0603	0603	GRM188R71E474KA12D	MuRata
C11、C12	2	20pF	电容, 陶瓷, 20pF, 100V, +/-5%, C0G/NP0, 0805	0805	08051A200JAT2A	AVX
C14	1	10 $\mu$ F	电容, 陶瓷, 10 $\mu$ F, 25V, +/-10%, X7R, 1210	1210	C1210C106K3RACTU	Kemet
C20	1	1 $\mu$ F	电容, 陶瓷, 1 $\mu$ F, 25V, +/-20%, X7R, AEC-Q200 1 级, 0603	0603	CGA3E1X7R1E105M080AC	TDK
C21	1	22 $\mu$ F	电容, 陶瓷, 22 $\mu$ F, 6.3V, +/-20%, X6S, 0603	0603	GRM188C80J226ME15D	MuRata
C22、C23	2	10pF	电容, 陶瓷, 10pF, 50V, +/-5%, C0G/NP0, 0603	0603	C0603C100J5GACTU	Kemet
D1、D2、D3	3		150V (典型值) 钳位, 1pp, Tvs 二极管, 表面贴装, 0603 (公制 1608)	0603	PGB1010603MRHF	Littelfuse Inc
F1	1		保险丝, 0.5A, 50VDC, SMD	0603	SF-0603F050-2	Bourns
H1、H2、H3、H4	4		机械螺钉, 圆头, #4-40 x 1/4, 尼龙, 飞利浦盘形头	螺钉	NY PMS 440 0025 PH	B&F Fastener Supply
H5、H6、H7、H8	4		六角螺柱, 0.5"L #4-40, 尼龙	螺柱	1902C	Keystone
J1	1		标准香蕉插孔, 绝缘, 10A, 红色	571-0500	571-0500	DEM Manufacturing
J2	1		标准香蕉插孔, 绝缘, 10A, 黑色	571-0100	571-0100	DEM Manufacturing
J3、J6	2		接头, 100mil, 3x2, 金, TH	3x2 接头	TSW-103-07-G-D	Samtec
J4、J5、J7、J8、J16	5		接头, 100mil, 3x1, 金, TH	接头, 100mil, 3x1, TH	HTSW-103-07-G-S	Samtec
J9	1		接头, 100mil, 2x2, 金, TH	2x2 接头	TSW-102-07-G-D	Samtec
J10	1		接头, 100mil, 2x1, 金, TH	2x1 接头	TSW-102-07-G-S	Samtec
J11、J15	2		连接器, 末端发射 SMA, 50 欧姆, SMT	末端发射 SMA	142-0701-801	Cinch Connectivity

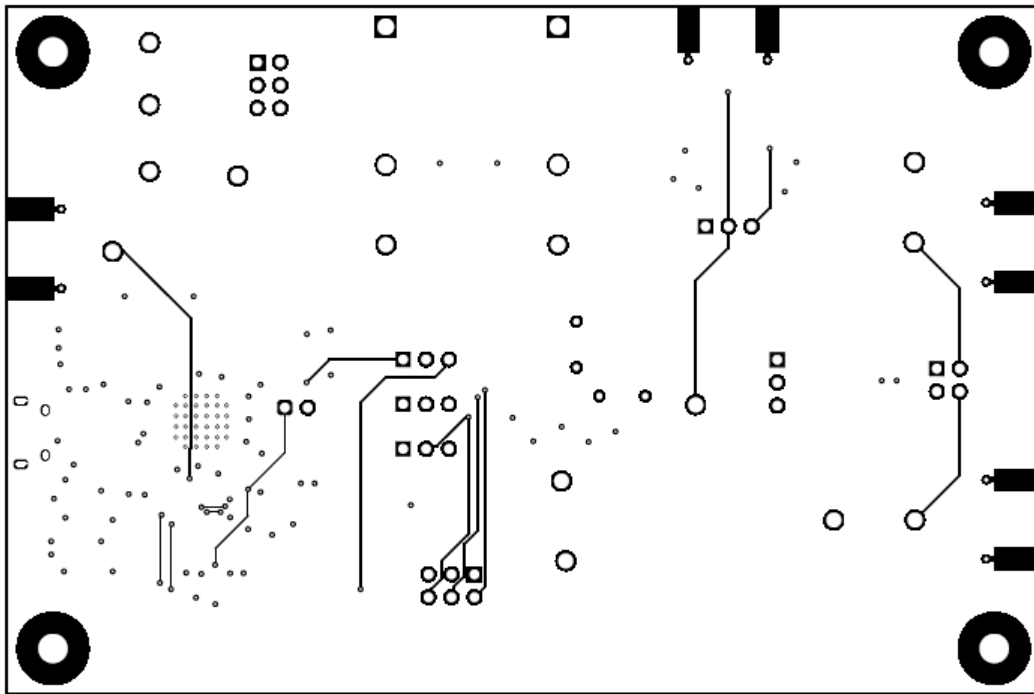
表 4-1. BOM (续)

位号	数量	值	说明	封装参考	器件型号	制造商
J12	1		插座, USB 2.0, Micro-USB Type B, R/A, SMT	USB-micro B USB 2.0, 0.65mm, 5 Pos, R/A, SMT	10118194-0001LF	FCI
L1	1	600 Ω	铁氧体磁珠, 600Ω (在 100MHz 时), 1A, 0603	0603	782633601	Wurth Elektronik
LBL1	1		热转印打印标签, 0.650" (宽) x 0.200" (高) - 10,000/卷	PCB 标签, 0.650 x 0.200 英寸	THT-14-423-10	Brady
R1	1	10.0k Ω	电阻, 10 Ω k, 0.1%, 0.0625W, 0402	0402	RT0402BRD0710KL	Yageo America
R2、R3	2	10 Ω	电阻, 10 Ω, 1%, 0.1W, 0603	0603	RC0603FR-0710RL	Yageo
R4	1	12.0k Ω	电阻, 12k Ω, 1%, 0.1W, 0603	0603	RC0603FR-0712KL	Yageo
R5	1	47.0k Ω	电阻, 47k Ω, 1%, 0.1W, 0603	0603	RC0603FR-0747KL	Yageo
R6、R13、R14、R15	4	2.00k Ω	电阻, 2.00k Ω, 0.1%, 0.1W, 0603	0603	RG1608P-202-B-T5	Susumu Co Ltd
R7	1	1.00M Ω	电阻, 1M Ω, 1%, 0.1W, AEC-Q200 0 级, 0603	0603	RMCF0603FG1M00	Stackpole Electronics Inc
R8、R11、R12、R16	4	0	电阻, 0 Ω, 5%, 0.1W, 0603	0603	RC0603JR-070RL	Yageo
SH1、SH2、SH3、 SH4、SH5、SH6	6		分流器, 100mil, 镀金, 黑色	分流器, 2 位, 100mil	881545-2	TE Connectivity
TP1、TP2、TP3、TP10	4		测试点, 紧凑, 红色, TH	红色紧凑型测试点	5005	Keystone Electronics
TP5、TP6、TP7、 TP8、TP9	5		测试点, 多用途, 黑色, TH	黑色通用测试点	5011	Keystone Electronics
TP11、TP12、TP13、 TP14	4		测试点, 紧凑型, 白色, TH	白色紧凑型测试点	5007	Keystone Electronics
U1	1		DAC8N041DGK	VSSOP8	DAC8N041DGK	德州仪器 (TI)
U2	1		低噪声, 极低温漂, 精密电压基准, -40 至 125°C, 8 引脚 SOIC (D), 绿色 (符合 RoHS 标 准, 无锡/溴)	D0008A	REF5025AID	德州仪器 (TI)
U3	1		500mA、低 IQ、小型低压降稳压器, DBV0005A (SOT-23-5)	DBV0005A	TLV75533PDBVR	德州仪器 (TI)

表 4-1. BOM (续)

位号	数量	值	说明	封装参考	器件型号	制造商
U4	1		单路输出低输入电压要求 LDO, 150mA, 固定 1.8V 输出, 1.8 至 5.5V 输入, 具有低 IQ, 5 引脚 SOT-23 (DBV), -40 至 125°C, 绿色环保 (符合 RoHS 标准, 无镉/溴)	DBV0005A	TPS72118DBVR	德州仪器 (TI)
U5	1		具有施密特触发输入和三态输出的 4 位定向电压电平转换器	UQFN12	TXU0104RUT	德州仪器 (TI)
U6	1		Future Technology Devices International Ltd FT4232H 四路高速 USB 转通用 UART/MPSSSE IC, VQFN-56	VQFN-56	FT4232H-56Q-TRAY	FTDI
U7	1		具有施密特触发输入和三态输出的汽车类 4 位定向电压电平转换器	UQFN12	TXU0304RUT	德州仪器 (TI)
U8	1		具有漏极开路输出的汽车类单路缓冲器/驱动器, DBV0005A (SOT-23-5)	DBV0005A	SN74LVC1G07QDBVRQ1	德州仪器 (TI)
Y1	1		晶振, 12MHz, 18pF, SMD	ABM3	ABM3-12.000MHZ-B2-T	Abracon Corporation

## 5 其他信息

### 5.1 商标

LabVIEW™ is a trademark of National Instruments.

Windows® is a registered trademark of Microsoft Corporation.

所有商标均为其各自所有者的财产。

## STANDARD TERMS FOR EVALUATION MODULES

1. *Delivery:* TI delivers TI evaluation boards, kits, or modules, including any accompanying demonstration software, components, and/or documentation which may be provided together or separately (collectively, an "EVM" or "EVMs") to the User ("User") in accordance with the terms set forth herein. User's acceptance of the EVM is expressly subject to the following terms.
  - 1.1 EVMs are intended solely for product or software developers for use in a research and development setting to facilitate feasibility evaluation, experimentation, or scientific analysis of TI semiconductors products. EVMs have no direct function and are not finished products. EVMs shall not be directly or indirectly assembled as a part or subassembly in any finished product. For clarification, any software or software tools provided with the EVM ("Software") shall not be subject to the terms and conditions set forth herein but rather shall be subject to the applicable terms that accompany such Software
  - 1.2 EVMs are not intended for consumer or household use. EVMs may not be sold, sublicensed, leased, rented, loaned, assigned, or otherwise distributed for commercial purposes by Users, in whole or in part, or used in any finished product or production system.
2. *Limited Warranty and Related Remedies/Disclaimers:*
  - 2.1 These terms do not apply to Software. The warranty, if any, for Software is covered in the applicable Software License Agreement.
  - 2.2 TI warrants that the TI EVM will conform to TI's published specifications for ninety (90) days after the date TI delivers such EVM to User. Notwithstanding the foregoing, TI shall not be liable for a nonconforming EVM if (a) the nonconformity was caused by neglect, misuse or mistreatment by an entity other than TI, including improper installation or testing, or for any EVMs that have been altered or modified in any way by an entity other than TI, (b) the nonconformity resulted from User's design, specifications or instructions for such EVMs or improper system design, or (c) User has not paid on time. Testing and other quality control techniques are used to the extent TI deems necessary. TI does not test all parameters of each EVM. User's claims against TI under this Section 2 are void if User fails to notify TI of any apparent defects in the EVMs within ten (10) business days after delivery, or of any hidden defects with ten (10) business days after the defect has been detected.
  - 2.3 TI's sole liability shall be at its option to repair or replace EVMs that fail to conform to the warranty set forth above, or credit User's account for such EVM. TI's liability under this warranty shall be limited to EVMs that are returned during the warranty period to the address designated by TI and that are determined by TI not to conform to such warranty. If TI elects to repair or replace such EVM, TI shall have a reasonable time to repair such EVM or provide replacements. Repaired EVMs shall be warranted for the remainder of the original warranty period. Replaced EVMs shall be warranted for a new full ninety (90) day warranty period.

### **WARNING**

**Evaluation Kits are intended solely for use by technically qualified, professional electronics experts who are familiar with the dangers and application risks associated with handling electrical mechanical components, systems, and subsystems.**

**User shall operate the Evaluation Kit within TI's recommended guidelines and any applicable legal or environmental requirements as well as reasonable and customary safeguards. Failure to set up and/or operate the Evaluation Kit within TI's recommended guidelines may result in personal injury or death or property damage. Proper set up entails following TI's instructions for electrical ratings of interface circuits such as input, output and electrical loads.**

**NOTE:**

**EXPOSURE TO ELECTROSTATIC DISCHARGE (ESD) MAY CAUSE DEGRADATION OR FAILURE OF THE EVALUATION KIT; TI RECOMMENDS STORAGE OF THE EVALUATION KIT IN A PROTECTIVE ESD BAG.**

### 3 Regulatory Notices:

#### 3.1 United States

##### 3.1.1 Notice applicable to EVMs not FCC-Approved:

**FCC NOTICE:** This kit is designed to allow product developers to evaluate electronic components, circuitry, or software associated with the kit to determine whether to incorporate such items in a finished product and software developers to write software applications for use with the end product. This kit is not a finished product and when assembled may not be resold or otherwise marketed unless all required FCC equipment authorizations are first obtained. Operation is subject to the condition that this product not cause harmful interference to licensed radio stations and that this product accept harmful interference. Unless the assembled kit is designed to operate under part 15, part 18 or part 95 of this chapter, the operator of the kit must operate under the authority of an FCC license holder or must secure an experimental authorization under part 5 of this chapter.

##### 3.1.2 For EVMs annotated as FCC – FEDERAL COMMUNICATIONS COMMISSION Part 15 Compliant:

#### **CAUTION**

This device complies with part 15 of the FCC Rules. Operation is subject to the following two conditions: (1) This device may not cause harmful interference, and (2) this device must accept any interference received, including interference that may cause undesired operation.

Changes or modifications not expressly approved by the party responsible for compliance could void the user's authority to operate the equipment.

#### **FCC Interference Statement for Class A EVM devices**

*NOTE: This equipment has been tested and found to comply with the limits for a Class A digital device, pursuant to part 15 of the FCC Rules. These limits are designed to provide reasonable protection against harmful interference when the equipment is operated in a commercial environment. This equipment generates, uses, and can radiate radio frequency energy and, if not installed and used in accordance with the instruction manual, may cause harmful interference to radio communications. Operation of this equipment in a residential area is likely to cause harmful interference in which case the user will be required to correct the interference at his own expense.*

#### **FCC Interference Statement for Class B EVM devices**

*NOTE: This equipment has been tested and found to comply with the limits for a Class B digital device, pursuant to part 15 of the FCC Rules. These limits are designed to provide reasonable protection against harmful interference in a residential installation. This equipment generates, uses and can radiate radio frequency energy and, if not installed and used in accordance with the instructions, may cause harmful interference to radio communications. However, there is no guarantee that interference will not occur in a particular installation. If this equipment does cause harmful interference to radio or television reception, which can be determined by turning the equipment off and on, the user is encouraged to try to correct the interference by one or more of the following measures:*

- Reorient or relocate the receiving antenna.
- Increase the separation between the equipment and receiver.
- Connect the equipment into an outlet on a circuit different from that to which the receiver is connected.
- Consult the dealer or an experienced radio/TV technician for help.

#### 3.2 Canada

##### 3.2.1 For EVMs issued with an Industry Canada Certificate of Conformance to RSS-210 or RSS-247

#### **Concerning EVMs Including Radio Transmitters:**

This device complies with Industry Canada license-exempt RSSs. Operation is subject to the following two conditions:

(1) this device may not cause interference, and (2) this device must accept any interference, including interference that may cause undesired operation of the device.

#### **Concernant les EVMs avec appareils radio:**

Le présent appareil est conforme aux CNR d'Industrie Canada applicables aux appareils radio exempts de licence. L'exploitation est autorisée aux deux conditions suivantes: (1) l'appareil ne doit pas produire de brouillage, et (2) l'utilisateur de l'appareil doit accepter tout brouillage radioélectrique subi, même si le brouillage est susceptible d'en compromettre le fonctionnement.

#### **Concerning EVMs Including Detachable Antennas:**

Under Industry Canada regulations, this radio transmitter may only operate using an antenna of a type and maximum (or lesser) gain approved for the transmitter by Industry Canada. To reduce potential radio interference to other users, the antenna type and its gain should be so chosen that the equivalent isotropically radiated power (e.i.r.p.) is not more than that necessary for successful communication. This radio transmitter has been approved by Industry Canada to operate with the antenna types listed in the user guide with the maximum permissible gain and required antenna impedance for each antenna type indicated. Antenna types not included in this list, having a gain greater than the maximum gain indicated for that type, are strictly prohibited for use with this device.

### Concernant les EVMs avec antennes détachables

Conformément à la réglementation d'Industrie Canada, le présent émetteur radio peut fonctionner avec une antenne d'un type et d'un gain maximal (ou inférieur) approuvé pour l'émetteur par Industrie Canada. Dans le but de réduire les risques de brouillage radioélectrique à l'intention des autres utilisateurs, il faut choisir le type d'antenne et son gain de sorte que la puissance isotrope rayonnée équivalente (p.i.r.e.) ne dépasse pas l'intensité nécessaire à l'établissement d'une communication satisfaisante. Le présent émetteur radio a été approuvé par Industrie Canada pour fonctionner avec les types d'antenne énumérés dans le manuel d'usage et ayant un gain admissible maximal et l'impédance requise pour chaque type d'antenne. Les types d'antenne non inclus dans cette liste, ou dont le gain est supérieur au gain maximal indiqué, sont strictement interdits pour l'exploitation de l'émetteur.

#### 3.3 Japan

3.3.1 *Notice for EVMs delivered in Japan:* Please see [http://www.tij.co.jp/lstds/ti\\_ja/general/eStore/notice\\_01.page](http://www.tij.co.jp/lstds/ti_ja/general/eStore/notice_01.page) 日本国内に輸入される評価用キット、ボードについては、次のところをご覧ください。

<https://www.ti.com/ja-jp/legal/notice-for-evaluation-kits-delivered-in-japan.html>

3.3.2 *Notice for Users of EVMs Considered "Radio Frequency Products" in Japan:* EVMs entering Japan may not be certified by TI as conforming to Technical Regulations of Radio Law of Japan.

If User uses EVMs in Japan, not certified to Technical Regulations of Radio Law of Japan, User is required to follow the instructions set forth by Radio Law of Japan, which includes, but is not limited to, the instructions below with respect to EVMs (which for the avoidance of doubt are stated strictly for convenience and should be verified by User):

1. Use EVMs in a shielded room or any other test facility as defined in the notification #173 issued by Ministry of Internal Affairs and Communications on March 28, 2006, based on Sub-section 1.1 of Article 6 of the Ministry's Rule for Enforcement of Radio Law of Japan,
2. Use EVMs only after User obtains the license of Test Radio Station as provided in Radio Law of Japan with respect to EVMs, or
3. Use of EVMs only after User obtains the Technical Regulations Conformity Certification as provided in Radio Law of Japan with respect to EVMs. Also, do not transfer EVMs, unless User gives the same notice above to the transferee. Please note that if User does not follow the instructions above, User will be subject to penalties of Radio Law of Japan.

【無線電波を送信する製品の開発キットをお使いになる際の注意事項】 開発キットの中には技術基準適合証明を受けていないものがあります。技術適合証明を受けていないものご使用に際しては、電波法遵守のため、以下のいずれかの措置を取っていただく必要がありますのでご注意ください。

1. 電波法施行規則第6条第1項第1号に基づく平成18年3月28日総務省告示第173号で定められた電波暗室等の試験設備でご使用いただく。
2. 実験局の免許を取得後ご使用いただく。
3. 技術基準適合証明を取得後ご使用いただく。

なお、本製品は、上記の「ご使用にあたっての注意」を譲渡先、移転先に通知しない限り、譲渡、移転できないものとします。

上記を遵守頂けない場合は、電波法の罰則が適用される可能性があることをご留意ください。日本テキサス・イ

ンスツルメンツ株式会社

東京都新宿区西新宿 6 丁目 2 4 番 1 号

西新宿三井ビル

3.3.3 *Notice for EVMs for Power Line Communication:* Please see [http://www.tij.co.jp/lstds/ti\\_ja/general/eStore/notice\\_02.page](http://www.tij.co.jp/lstds/ti_ja/general/eStore/notice_02.page)

電力線搬送波通信についての開発キットをお使いになる際の注意事項については、次のところをご覧ください。 <https://www.ti.com/ja-jp/legal/notice-for-evaluation-kits-for-power-line-communication.html>

#### 3.4 European Union

3.4.1 *For EVMs subject to EU Directive 2014/30/EU (Electromagnetic Compatibility Directive):*

This is a class A product intended for use in environments other than domestic environments that are connected to a low-voltage power-supply network that supplies buildings used for domestic purposes. In a domestic environment this product may cause radio interference in which case the user may be required to take adequate measures.

- 
4. *EVM Use Restrictions and Warnings:*
    - 4.1 EVMS ARE NOT FOR USE IN FUNCTIONAL SAFETY AND/OR SAFETY CRITICAL EVALUATIONS, INCLUDING BUT NOT LIMITED TO EVALUATIONS OF LIFE SUPPORT APPLICATIONS.
    - 4.2 User must read and apply the user guide and other available documentation provided by TI regarding the EVM prior to handling or using the EVM, including without limitation any warning or restriction notices. The notices contain important safety information related to, for example, temperatures and voltages.
    - 4.3 *Safety-Related Warnings and Restrictions:*
      - 4.3.1 User shall operate the EVM within TI's recommended specifications and environmental considerations stated in the user guide, other available documentation provided by TI, and any other applicable requirements and employ reasonable and customary safeguards. Exceeding the specified performance ratings and specifications (including but not limited to input and output voltage, current, power, and environmental ranges) for the EVM may cause personal injury or death, or property damage. If there are questions concerning performance ratings and specifications, User should contact a TI field representative prior to connecting interface electronics including input power and intended loads. Any loads applied outside of the specified output range may also result in unintended and/or inaccurate operation and/or possible permanent damage to the EVM and/or interface electronics. Please consult the EVM user guide prior to connecting any load to the EVM output. If there is uncertainty as to the load specification, please contact a TI field representative. During normal operation, even with the inputs and outputs kept within the specified allowable ranges, some circuit components may have elevated case temperatures. These components include but are not limited to linear regulators, switching transistors, pass transistors, current sense resistors, and heat sinks, which can be identified using the information in the associated documentation. When working with the EVM, please be aware that the EVM may become very warm.
      - 4.3.2 EVMs are intended solely for use by technically qualified, professional electronics experts who are familiar with the dangers and application risks associated with handling electrical mechanical components, systems, and subsystems. User assumes all responsibility and liability for proper and safe handling and use of the EVM by User or its employees, affiliates, contractors or designees. User assumes all responsibility and liability to ensure that any interfaces (electronic and/or mechanical) between the EVM and any human body are designed with suitable isolation and means to safely limit accessible leakage currents to minimize the risk of electrical shock hazard. User assumes all responsibility and liability for any improper or unsafe handling or use of the EVM by User or its employees, affiliates, contractors or designees.
    - 4.4 User assumes all responsibility and liability to determine whether the EVM is subject to any applicable international, federal, state, or local laws and regulations related to User's handling and use of the EVM and, if applicable, User assumes all responsibility and liability for compliance in all respects with such laws and regulations. User assumes all responsibility and liability for proper disposal and recycling of the EVM consistent with all applicable international, federal, state, and local requirements.
  5. *Accuracy of Information:* To the extent TI provides information on the availability and function of EVMs, TI attempts to be as accurate as possible. However, TI does not warrant the accuracy of EVM descriptions, EVM availability or other information on its websites as accurate, complete, reliable, current, or error-free.
  6. *Disclaimers:*
    - 6.1 EXCEPT AS SET FORTH ABOVE, EVMS AND ANY MATERIALS PROVIDED WITH THE EVM (INCLUDING, BUT NOT LIMITED TO, REFERENCE DESIGNS AND THE DESIGN OF THE EVM ITSELF) ARE PROVIDED "AS IS" AND "WITH ALL FAULTS." TI DISCLAIMS ALL OTHER WARRANTIES, EXPRESS OR IMPLIED, REGARDING SUCH ITEMS, INCLUDING BUT NOT LIMITED TO ANY EPIDEMIC FAILURE WARRANTY OR IMPLIED WARRANTIES OF MERCHANTABILITY OR FITNESS FOR A PARTICULAR PURPOSE OR NON-INFRINGEMENT OF ANY THIRD PARTY PATENTS, COPYRIGHTS, TRADE SECRETS OR OTHER INTELLECTUAL PROPERTY RIGHTS.
    - 6.2 EXCEPT FOR THE LIMITED RIGHT TO USE THE EVM SET FORTH HEREIN, NOTHING IN THESE TERMS SHALL BE CONSTRUED AS GRANTING OR CONFERRING ANY RIGHTS BY LICENSE, PATENT, OR ANY OTHER INDUSTRIAL OR INTELLECTUAL PROPERTY RIGHT OF TI, ITS SUPPLIERS/LICENSORS OR ANY OTHER THIRD PARTY, TO USE THE EVM IN ANY FINISHED END-USER OR READY-TO-USE FINAL PRODUCT, OR FOR ANY INVENTION, DISCOVERY OR IMPROVEMENT, REGARDLESS OF WHEN MADE, CONCEIVED OR ACQUIRED.
  7. *USER'S INDEMNITY OBLIGATIONS AND REPRESENTATIONS.* USER WILL DEFEND, INDEMNIFY AND HOLD TI, ITS LICENSORS AND THEIR REPRESENTATIVES HARMLESS FROM AND AGAINST ANY AND ALL CLAIMS, DAMAGES, LOSSES, EXPENSES, COSTS AND LIABILITIES (COLLECTIVELY, "CLAIMS") ARISING OUT OF OR IN CONNECTION WITH ANY HANDLING OR USE OF THE EVM THAT IS NOT IN ACCORDANCE WITH THESE TERMS. THIS OBLIGATION SHALL APPLY WHETHER CLAIMS ARISE UNDER STATUTE, REGULATION, OR THE LAW OF TORT, CONTRACT OR ANY OTHER LEGAL THEORY, AND EVEN IF THE EVM FAILS TO PERFORM AS DESCRIBED OR EXPECTED.
-

8. *Limitations on Damages and Liability:*

8.1 *General Limitations.* IN NO EVENT SHALL TI BE LIABLE FOR ANY SPECIAL, COLLATERAL, INDIRECT, PUNITIVE, INCIDENTAL, CONSEQUENTIAL, OR EXEMPLARY DAMAGES IN CONNECTION WITH OR ARISING OUT OF THESE TERMS OR THE USE OF THE EVMS , REGARDLESS OF WHETHER TI HAS BEEN ADVISED OF THE POSSIBILITY OF SUCH DAMAGES. EXCLUDED DAMAGES INCLUDE, BUT ARE NOT LIMITED TO, COST OF REMOVAL OR REINSTALLATION, ANCILLARY COSTS TO THE PROCUREMENT OF SUBSTITUTE GOODS OR SERVICES, RETESTING, OUTSIDE COMPUTER TIME, LABOR COSTS, LOSS OF GOODWILL, LOSS OF PROFITS, LOSS OF SAVINGS, LOSS OF USE, LOSS OF DATA, OR BUSINESS INTERRUPTION. NO CLAIM, SUIT OR ACTION SHALL BE BROUGHT AGAINST TI MORE THAN TWELVE (12) MONTHS AFTER THE EVENT THAT GAVE RISE TO THE CAUSE OF ACTION HAS OCCURRED.

8.2 *Specific Limitations.* IN NO EVENT SHALL TI'S AGGREGATE LIABILITY FROM ANY USE OF AN EVM PROVIDED HEREUNDER, INCLUDING FROM ANY WARRANTY, INDEMNITY OR OTHER OBLIGATION ARISING OUT OF OR IN CONNECTION WITH THESE TERMS, , EXCEED THE TOTAL AMOUNT PAID TO TI BY USER FOR THE PARTICULAR EVM(S) AT ISSUE DURING THE PRIOR TWELVE (12) MONTHS WITH RESPECT TO WHICH LOSSES OR DAMAGES ARE CLAIMED. THE EXISTENCE OF MORE THAN ONE CLAIM SHALL NOT ENLARGE OR EXTEND THIS LIMIT.

9. *Return Policy.* Except as otherwise provided, TI does not offer any refunds, returns, or exchanges. Furthermore, no return of EVM(s) will be accepted if the package has been opened and no return of the EVM(s) will be accepted if they are damaged or otherwise not in a resalable condition. If User feels it has been incorrectly charged for the EVM(s) it ordered or that delivery violates the applicable order, User should contact TI. All refunds will be made in full within thirty (30) working days from the return of the components(s), excluding any postage or packaging costs.

10. *Governing Law:* These terms and conditions shall be governed by and interpreted in accordance with the laws of the State of Texas, without reference to conflict-of-laws principles. User agrees that non-exclusive jurisdiction for any dispute arising out of or relating to these terms and conditions lies within courts located in the State of Texas and consents to venue in Dallas County, Texas. Notwithstanding the foregoing, any judgment may be enforced in any United States or foreign court, and TI may seek injunctive relief in any United States or foreign court.

Mailing Address: Texas Instruments, Post Office Box 655303, Dallas, Texas 75265  
Copyright © 2023, Texas Instruments Incorporated

## 重要通知和免责声明

TI“按原样”提供技术和可靠性数据（包括数据表）、设计资源（包括参考设计）、应用或其他设计建议、网络工具、安全信息和其他资源，不保证没有瑕疵且不做任何明示或暗示的担保，包括但不限于对适销性、与某特定用途的适用性或不侵犯任何第三方知识产权的暗示担保。

这些资源可供使用 TI 产品进行设计的熟练开发人员使用。您将自行承担以下全部责任：(1) 针对您的应用选择合适的 TI 产品，(2) 设计、验证并测试您的应用，(3) 确保您的应用满足相应标准以及任何其他安全、安保法规或其他要求。

这些资源如有变更，恕不另行通知。TI 授权您仅可将这些资源用于研发本资源所述的 TI 产品的相关应用。严禁以其他方式对这些资源进行复制或展示。您无权使用任何其他 TI 知识产权或任何第三方知识产权。对于因您对这些资源的使用而对 TI 及其代表造成的任何索赔、损害、成本、损失和债务，您将全额赔偿，TI 对此概不负责。

TI 提供的产品受 [TI 销售条款](#)、[TI 通用质量指南](#) 或 [ti.com](#) 上其他适用条款或 TI 产品随附的其他适用条款的约束。TI 提供这些资源并不会扩展或以其他方式更改 TI 针对 TI 产品发布的适用的担保或担保免责声明。除非德州仪器 (TI) 明确将某产品指定为定制产品或客户特定产品，否则其产品均为按确定价格收入目录的标准通用器件。

TI 反对并拒绝您可能提出的任何其他或不同的条款。

版权所有 © 2026，德州仪器 (TI) 公司

最后更新日期：2025 年 10 月