

TS3USB221A 具有单使能端和 ESD 保护的高速 USB 2.0 (480Mbps) 1:2 多路复用器和多路信号分离器开关

1 特性

- 在 2.5V 至 3.3V V_{CC} 下运行
- $V_{I/O}$ 支持高达 5.5V 的信号
- 1.8V 兼容控制引脚输入
- \overline{OE} 禁用时采用低功耗模式 (1 μ A)
- $R_{ON} = 6\Omega$ (最大值)
- $\Delta R_{ON} = 0.2\Omega$ (典型值)
- $C_{IO(ON)} = 6\text{pf}$ (典型值)
- 低功耗 (最大值为 30 μ A)
- 高带宽 (典型值为 900MHz)
- 闩锁性能超过 100mA, 符合 JESD 78 II 类规范
- ESD 性能经测试符合 JEDEC JS-001 标准
 - 7000V 人体放电模型
 - 1000V 充电器件模型 (JEDEC JS-002)
- ESD 性能 I/O 接地
 - 12kV 人体放电模型

2 应用

- 为 USB 1.0、1.1 和 2.0 路由信号
- 手机
- 摄像头
- 笔记本电脑
- USB I/O 扩展

3 说明

TS3USB221A 器件是一款高带宽开关, 专为手持和消费类应用 (例如手机、数码相机和具有集线器的笔记本电脑或具有受限 USB I/O 的控制器) 中的高速 USB 2.0 信号切换而设计。此开关具有较宽的带宽 (900MHz), 这一特性使得信号传递具有最少的边缘失真和相位失真。该器件将 USB 主机器件差动输出复用到一个相应的输出 (共两个输出)。此开关为双向开关, 输出端高速信号具有极少或零衰减。该器件还具有低功耗模式, 可将功耗降低至 1 μ A, 适用于使用电池或具有有限功率预算的便携式应用。该器件经过精心设计, 可实现低位间偏移和高通道间噪声隔离, 并且与高速 USB 2.0 (480Mbps) 等各种标准兼容。

TS3USB221A 器件在所有引脚上集成了 ESD 保护单元, 采用微型 μ QFN 封装 (2mm \times 1.5mm), 在自然通风条件下的额定工作温度范围为 -40°C 至 85°C。

封装信息

器件型号	封装 ⁽¹⁾	封装尺寸 ⁽²⁾
TS3USB221A	RSE (UQFN, 10)	2mm \times 1.5mm

(1) 有关所有可用封装, 请参阅节 11。

(2) 封装尺寸 (长 \times 宽) 为标称值, 并包括引脚 (如适用)。

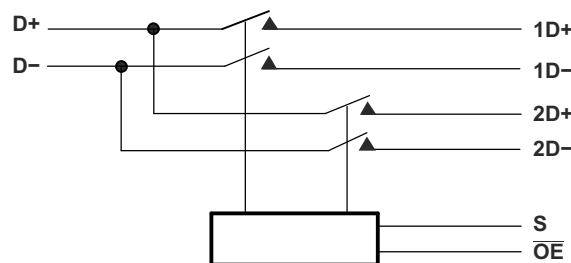

EN 是应用于开关的内部启用信号。

简化原理图



Table of Contents

1 特性	1	7.1 Overview.....	12
2 应用	1	7.2 Functional Block Diagram.....	12
3 说明	1	7.3 Feature Description.....	13
4 Pin Configuration and Functions	3	7.4 Device Functional Modes.....	13
5 Specifications	4	8 Application and Implementation	14
5.1 Absolute Maximum Ratings.....	4	8.1 Application Information.....	14
5.2 ESD Ratings.....	4	8.2 Typical Application.....	14
5.3 Recommended Operating Conditions.....	4	8.3 Power Supply Recommendations.....	15
5.4 Thermal Information.....	5	8.4 Layout.....	16
5.5 Electrical Characteristics.....	5	9 Device and Documentation Support	18
5.6 Dynamic Electrical Characteristics, $V_{CC} = 3.3V$ $\pm 10\%$	6	9.1 接收文档更新通知.....	18
5.7 Dynamic Electrical Characteristics, $V_{CC} = 2.5V$ $\pm 10\%$	6	9.2 支持资源.....	18
5.8 Switching Characteristics, $V_{CC} = 3.3V \pm 10\%$	6	9.3 Trademarks.....	18
5.9 Switching Characteristics, $V_{CC} = 2.5V \pm 10\%$	6	9.4 静电放电警告.....	18
5.10 Typical Characteristics.....	7	9.5 术语表.....	18
6 Parameter Measurement Information	8	10 Revision History	18
7 Detailed Description	12	11 Mechanical, Packaging, and Orderable Information	19

4 Pin Configuration and Functions



图 4-1. RSE Package, 10-Pin μ QFN (Top View)



图 4-2. RSE Package, 10-Pin μ QFN (Bottom View)

表 4-1. Pin Functions

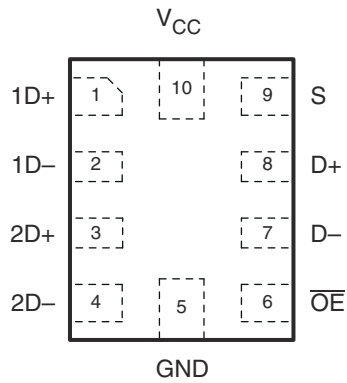
PIN		TYPE ⁽¹⁾	DESCRIPTION
NAME	NO.		
1D+	1	I/O	USB port 1
1D-	2	I/O	
2D+	3	I/O	USB port 2
2D-	4	I/O	
GND	5	—	Ground
OE	6	I	Bus-switch enable
D+	8	I/O	Common USB port
D-	7	I/O	
S	9	I	Select input
V _{CC}	10	—	Supply voltage

(1) I = input, O = output

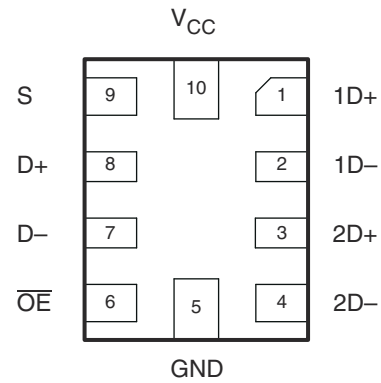
5 Specifications

5.1 Absolute Maximum Ratings

over operating free-air temperature range (unless otherwise noted) ⁽¹⁾

	MIN	MAX	UNIT
Supply voltage, V_{CC}	- 0.5	4.6	V
Control input voltage, $V_S, V_{\overline{OE}}$ ^{(2) (3)}	- 0.5	7	V
Switch I/O voltage, $V_{I/O}$ ^{(2) (3) (4)}	- 0.5	7	V
Control input clamp current, I_{IK}	$V_{IN} < 0$	- 50	mA
I/O port clamp current, $I_{I/OK}$	$V_{I/O} < 0$	- 50	mA
ON-state switch current, $I_{I/O}$ ⁽⁵⁾		±120	mA
Continuous current through V_{CC} or GND		±100	mA
T_{stg} Storage temperature range	- 65	150	°C

- (1) Operation outside the *Absolute Maximum Ratings* may cause permanent device damage. *Absolute Maximum Ratings* do not imply functional operation of the device at these or any other conditions beyond those listed under *Recommended Operating Conditions*. If used outside the *Recommended Operating Conditions* but within the *Absolute Maximum Ratings*, the device may not be fully functional, and this may affect device reliability, functionality, performance, and shorten the device lifetime.
- (2) All voltages are with respect to ground, unless otherwise specified.
- (3) The input and output voltage ratings may be exceeded if the input and output clamp-current ratings are observed.
- (4) V_I and V_O are used to denote specific conditions for $V_{I/O}$.
- (5) I_I and I_O are used to denote specific conditions for $I_{I/O}$.

5.2 ESD Ratings

		VALUE	UNIT
$V_{(ESD)}$ Electrostatic discharge	Human-body model (HBM), per ANSI/ESDA/JEDEC JS-001 ⁽¹⁾	All pins except I/O to GND	±7000
		I/O to GND	±12000
	Charged-device model (CDM), per ANSI/ESDA/JEDEC JS-002 ⁽²⁾	All pins	±1000

- (1) JEDEC document JEP155 states that 500V HBM allows safe manufacturing with a standard ESD control process. Manufacturing with less than 500V HBM is possible with the necessary precautions.
- (2) JEDEC document JEP157 states that 250V CDM allows safe manufacturing with a standard ESD control process. Manufacturing with less than 250V CDM is possible with the necessary precautions.

5.3 Recommended Operating Conditions

	MIN	MAX	UNIT
V_{CC} Supply voltage	2.3	3.6	V
$V_S, V_{\overline{OE}}$	High-level control input voltage	$V_{CC} = 2.3V$ to $2.7V$	$0.46 \times V_{CC}$ V_{CC}
		$V_{CC} = 2.7V$ to $3.6V$	$0.46 \times V_{CC}$ V_{CC}
	Low-level control input voltage	$V_{CC} = 2.3V$ to $2.7V$	0 $0.25 \times V_{CC}$
		$V_{CC} = 2.7V$ to $3.6V$	0 $0.25 \times V_{CC}$
$V_{I/O}$ Data input/output voltage ⁽¹⁾	0	5.5	V
T_A Operating free-air temperature	- 40	85	°C

- (1) The I/O pins are 5.5V tolerant and functional for the entire range. However, for $V_{I/O} > 3.6V$, channel RON will be high (up to 100Ω).

5.4 Thermal Information

THERMAL METRIC ⁽¹⁾		RSE (UQFN)	UNIT
		10 PINS	
$R_{\theta JA}$	Junction-to-ambient thermal resistance	204.8	°C/W
$R_{\theta JC(top)}$	Junction-to-case (top) thermal resistance	118.1	
$R_{\theta JB}$	Junction-to-board thermal resistance	121.5	
ψ_{JT}	Junction-to-top characterization parameter	13.9	
ψ_{JB}	Junction-to-board characterization parameter	121.2	

(1) For more information about traditional and new thermal metrics, see the [Semiconductor and IC Package Thermal Metrics](#) application note.

5.5 Electrical Characteristics

over operating free-air temperature range (unless otherwise noted) ⁽¹⁾

PARAMETER	TEST CONDITIONS	MIN	TYP ⁽²⁾	MAX	UNIT		
V_{IK}	Input-Source Clamp Voltage	$V_{CC} = 3.6V, 2.7V, I_I = -18\text{ mA}$			-1.8	V	
I_{IN}	Input leakage current, control inputs	$V_{CC} = 3.6V, 2.7V, 0V, V_{IN} = 0V\text{ to }3.6V$			±1	μA	
I_{OZ} ⁽³⁾	Off-state leakage current	$V_{CC} = 3.6V, 2.7V, V_O = 0V\text{ to }5.25V, V_I = 0V, V_{IN} = V_{CC}\text{ or GND, Switch OFF}$			±1	μA	
$I_{(OFF)}$	Power-off leakage current	$V_{CC} = 0V$	$V_{I/O} = 0V\text{ to }5.25V$	±2	μA		
			$V_{I/O} = 0V\text{ to }3.6V$	±2			
			$V_{I/O} = 0V\text{ to }2.7V$	±1			
I_{CC}	Supply Current	$V_{CC} = 3.6V, 2.7V, V_{IN} = V_{CC}\text{ or GND, } I_{I/O} = 0V, \text{ Switch ON or OFF}$			30	μA	
I_{CC}	Supply Current (low power mode)	$V_{CC} = 3.6V, 2.7V, V_{IN} = V_{CC}\text{ or GND, Switch disabled, OE in high state}$			1	μA	
ΔI_{CC} ⁽⁴⁾	Supply-current change, control inputs	One input at 1.8V, Other inputs at V_{CC} or GND	$V_{CC} = 3.6V$	20	μA		
			$V_{CC} = 2.7V$	0.5			
C_{in}	Input capacitance, control inputs	$V_{CC} = 3.3V, 2.5V, V_{IN} = V_{CC}\text{ or }0V$			1.5	2.5	pF
$C_{io(OFF)}$	OFF capacitance	$V_{CC} = 3.3V, 2.5V, V_{I/O} = V_{CC}\text{ or }0V, \text{ Switch OFF}$			3.5	5	pF
$C_{io(ON)}$	ON capacitance	$V_{CC} = 3.3V, 2.5V, V_{I/O} = V_{CC}\text{ or }0V, \text{ Switch ON}$			6	7.5	pF
R_{ON} ⁽⁵⁾	ON-state resistance	$V_{CC} = 3V, 2.3V$	$V_I = 0V, I_O = 30\text{ mA}$	3	6	Ω	
			$V_I = 2.4V, I_O = -15\text{ mA}$	3.4	6		
ΔR_{ON}	ON-state resistance match between channels	$V_{CC} = 3V, 2.3V$	$V_I = 0V, I_O = 30\text{ mA}$	0.2	Ω		
			$V_I = 1.7V, I_O = -15\text{ mA}$	0.2			
$R_{ON(Flat)}$	ON-state resistance flatness	$V_{CC} = 3V, 2.3V$	$V_I = 0V, I_O = 30\text{ mA}$	1	Ω		
			$V_I = 1.7V, I_O = -15\text{ mA}$	1			

(1) V_{IN} and I_{IN} refer to control inputs. V_I , V_O , I_I , and I_O refer to data pins.

(2) All typical values are at $V_{CC} = 3.3V$ (unless otherwise noted), $T_A = 25^\circ\text{C}$.

(3) For I/O ports, the parameter I_{OZ} includes the input leakage current.

(4) This is the increase in supply current for each input that is at the specified TTL voltage level, rather than V_{CC} or GND.

(5) Measured by the voltage drop between the A and B terminals at the indicated current through the switch. ON-state resistance is determined by the lower of the voltages of the two (A or B) terminals.

5.6 Dynamic Electrical Characteristics, $V_{CC} = 3.3V \pm 10\%$

over operating range, $T_A = -40^\circ C$ to $85^\circ C$, $V_{CC} = 3.3V \pm 10\%$, $GND = 0V$

PARAMETER		TEST CONDITIONS	MIN	TYP	MAX	UNIT
X_{TALK}	Crosstalk	$R_L = 50$, $f = 250MHz$		- 40		dB
O_{IRR}	OFF isolation	$R_L = 50$, $f = 250MHz$		- 41		dB
BW	Bandwidth (- 3 dB)	$R_L = 50$		0.9		GHz

5.7 Dynamic Electrical Characteristics, $V_{CC} = 2.5V \pm 10\%$

over operating range, $T_A = -40^\circ C$ to $85^\circ C$, $V_{CC} = 2.5V \pm 10\%$, $GND = 0V$

PARAMETER		TEST CONDITIONS	MIN	TYP	MAX	UNIT
X_{TALK}	Crosstalk	$R_L = 50$, $f = 250MHz$		- 39		dB
O_{IRR}	OFF isolation	$R_L = 50$, $f = 250MHz$		-40		dB
BW	Bandwidth (3 dB)	$R_L = 50$		0.9		GHz

5.8 Switching Characteristics, $V_{CC} = 3.3V \pm 10\%$

over operating range, $T_A = -40^\circ C$ to $85^\circ C$, $V_{CC} = 3.3V \pm 10\%$, $GND = 0V$

PARAMETER			MIN	TYP ⁽¹⁾	MAX	UNIT
t_{pd}	Propagation delay ^{(2) (3)}			0.25		ns
t_{ON}	Line enable time	S to D, nD			30	ns
		\overline{OE} to D, nD			17	
t_{OFF}	Line disable time	S to D, nD			12	ns
		\overline{OE} to D, nD			10	
$t_{SK(O)}$	Output skew between center port to any other port ⁽²⁾			0.1	0.2	ns
$t_{SK(P)}$	Skew between opposite transitions of the same output ($t_{PHL} - t_{PLH}$) ⁽²⁾			0.1	0.2	ns

- (1) For Max or Min conditions, use the appropriate value specified under Electrical Characteristics for the applicable device type.
- (2) Specified by design
- (3) The bus switch contributes no propagational delay other than the RC delay of the on resistance of the switch and the load capacitance. The time constant for the switch alone is of the order of 0.25ns for 10pF load. This time constant is much smaller than the rise/fall times of typical driving signals, therefore the time adds very little propagational delay to the system. Propagational delay of the bus switch, when used in a system, is determined by the driving circuit on the driving side of the switch and the switch interactions with the load on the driven side.

5.9 Switching Characteristics, $V_{CC} = 2.5V \pm 10\%$

over operating range, $T_A = -40^\circ C$ to $85^\circ C$, $V_{CC} = 2.5V \pm 10\%$, $GND = 0V$

PARAMETER			MIN	TYP ⁽¹⁾	MAX	UNIT
t_{pd}	Propagation delay ^{(2) (3)}			0.25		ns
t_{ON}	Line enable time	S to D, nD			50	ns
		\overline{OE} to D, nD			32	
t_{OFF}	Line disable time	S to D, nD			23	ns
		\overline{OE} to D, nD			12	
$t_{SK(O)}$	Output skew between center port to any other port ⁽²⁾			0.1	0.2	ns
$t_{SK(P)}$	Skew between opposite transitions of the same output ($t_{PHL} - t_{PLH}$) ⁽²⁾			0.1	0.2	ns

- (1) For Max or Min conditions, use the appropriate value specified under Electrical Characteristics for the applicable device type.
- (2) Specified by design
- (3) The bus switch contributes no propagational delay other than the RC delay of the on resistance of the switch and the load capacitance. The time constant for the switch alone is of the order of 0.25ns for 10pF load. This time constant is much smaller than the rise/fall times of typical driving signals, therefore the time adds very little propagational delay to the system. Propagational delay of the bus switch, when used in a system, is determined by the driving circuit on the driving side of the switch and the switch interactions with the load on the driven side.

5.10 Typical Characteristics

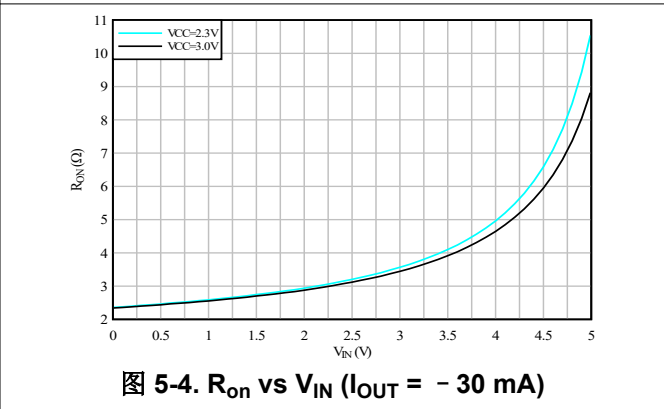
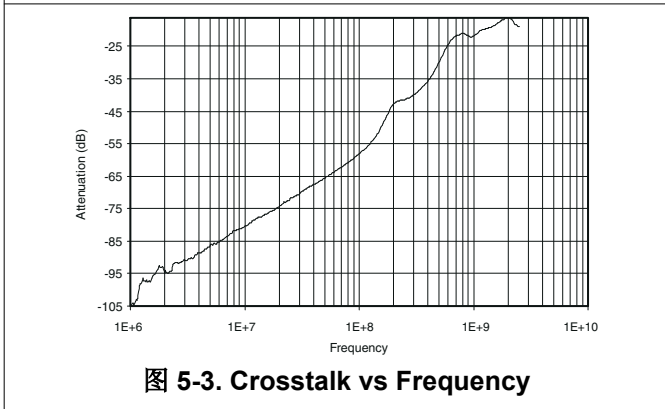
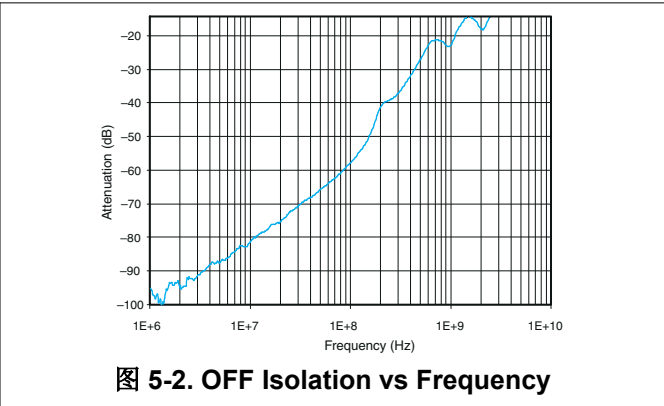
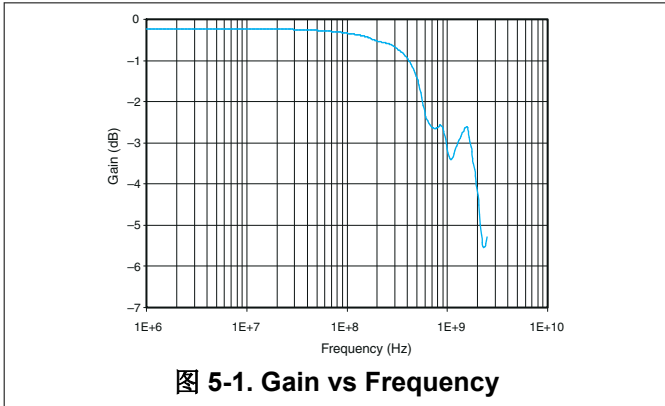

6 Parameter Measurement Information

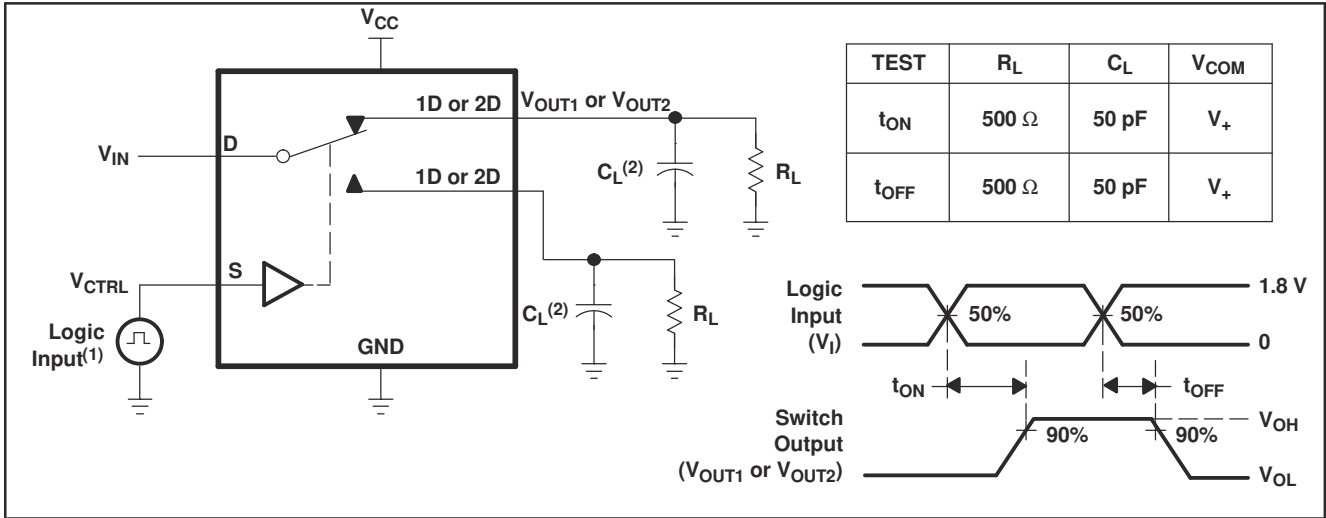

- (1) All input pulses are supplied by generators having the following characteristics: PRR ≤ 10 MHz, Z_O = 50 Ω, t_r < 5 ns, t_f < 5 ns.
- (2) C_L includes probe and jig capacitance.

图 6-1. Turn-On (t_{ON}) and Turn-Off Time (t_{OFF})



图 6-2. OFF Isolation (O_{ISO})



图 6-3. Crosstalk (X_{TALK})

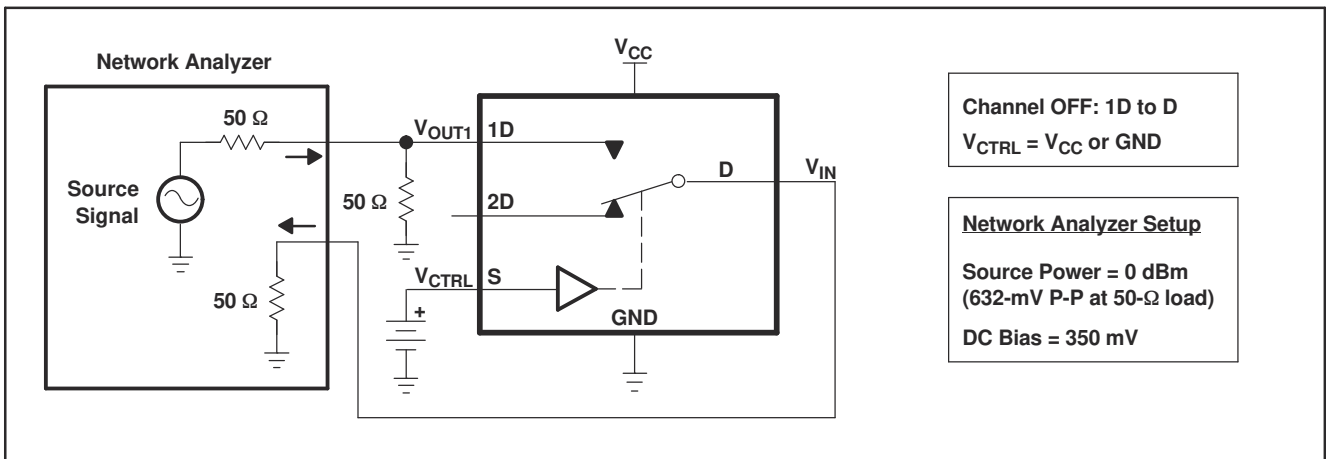

图 6-4. Bandwidth (BW)

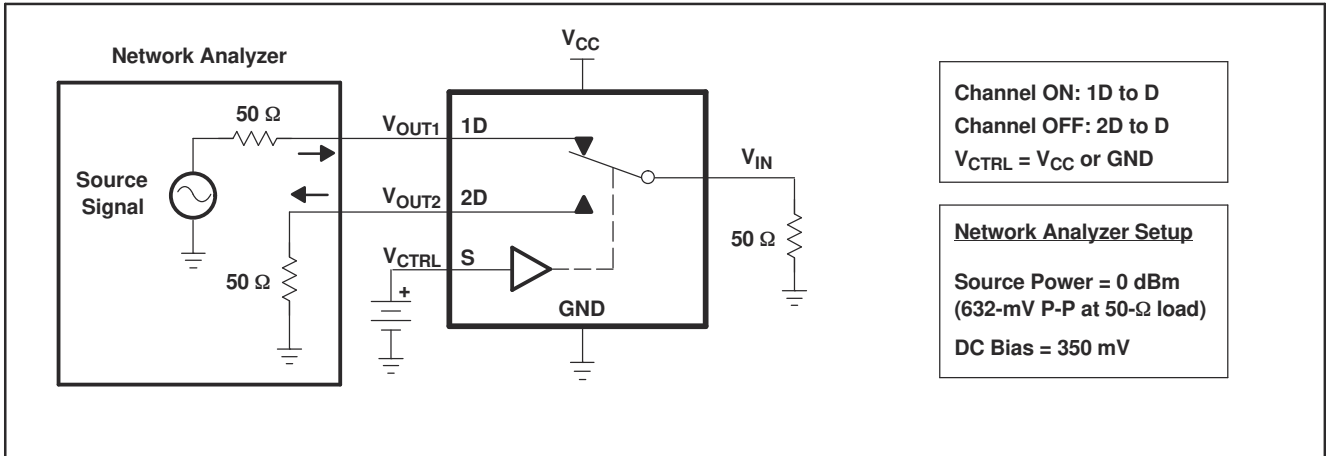

图 6-5. Propagation Delay

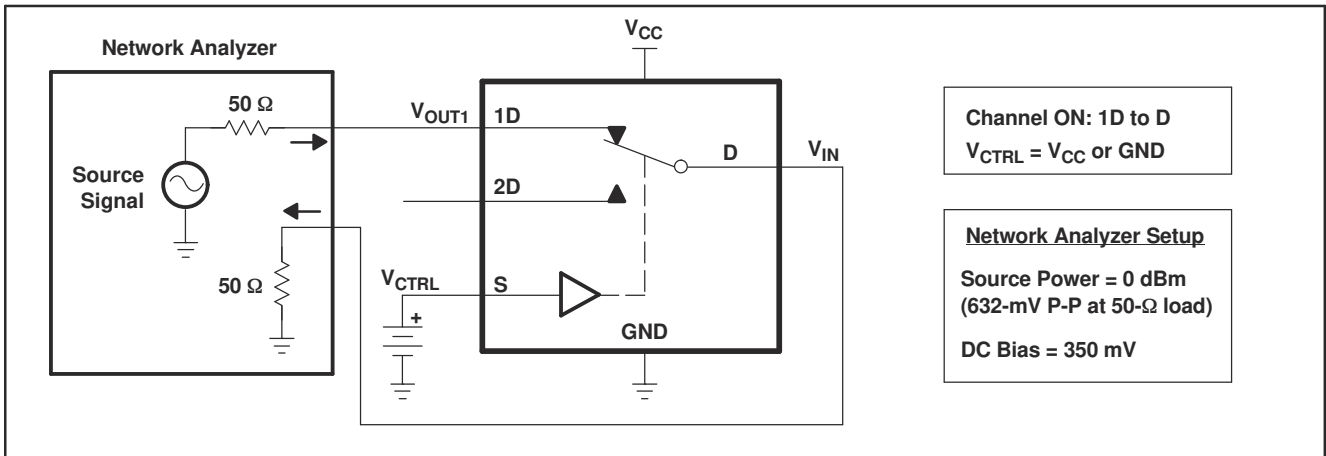

图 6-6. Skew Test

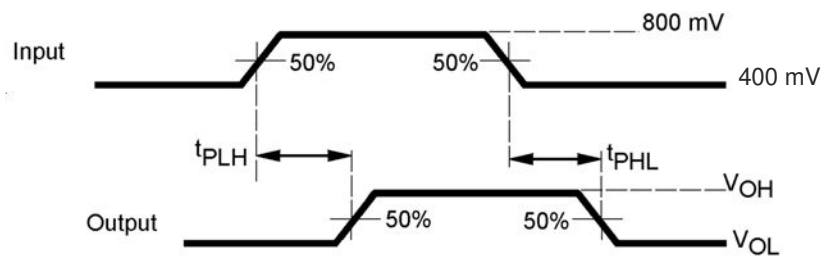

图 6-7. ON-State Resistance (r_{on})

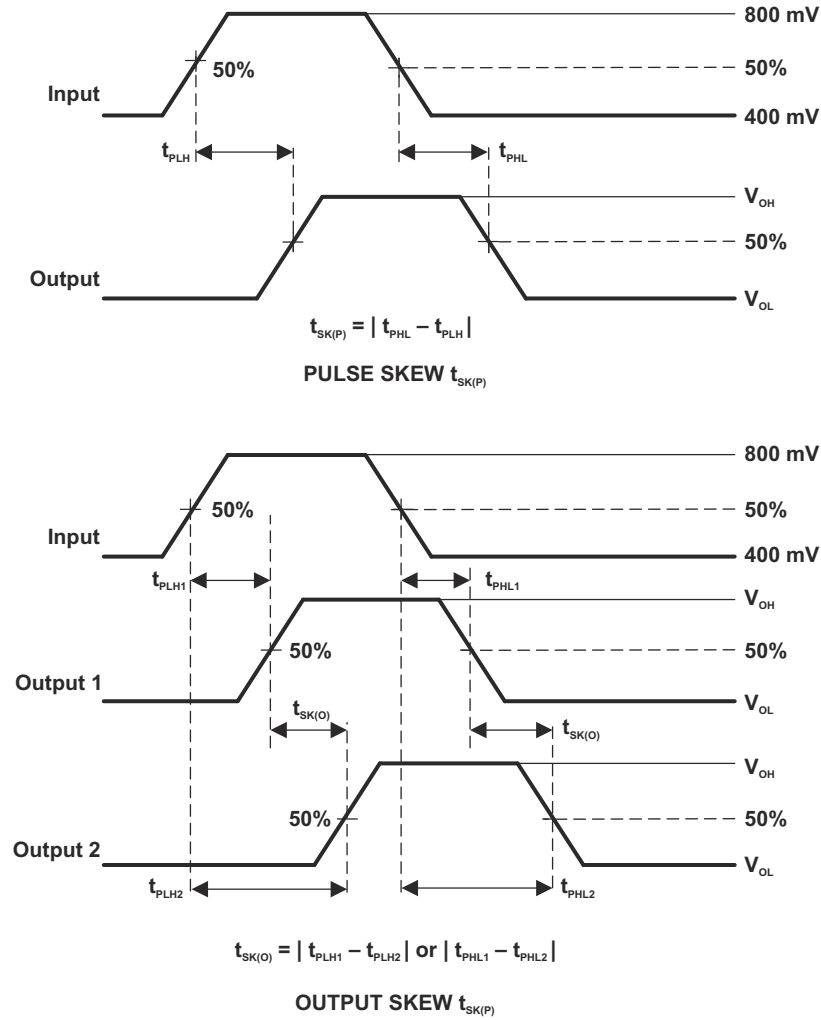

图 6-8. OFF-State Leakage Current

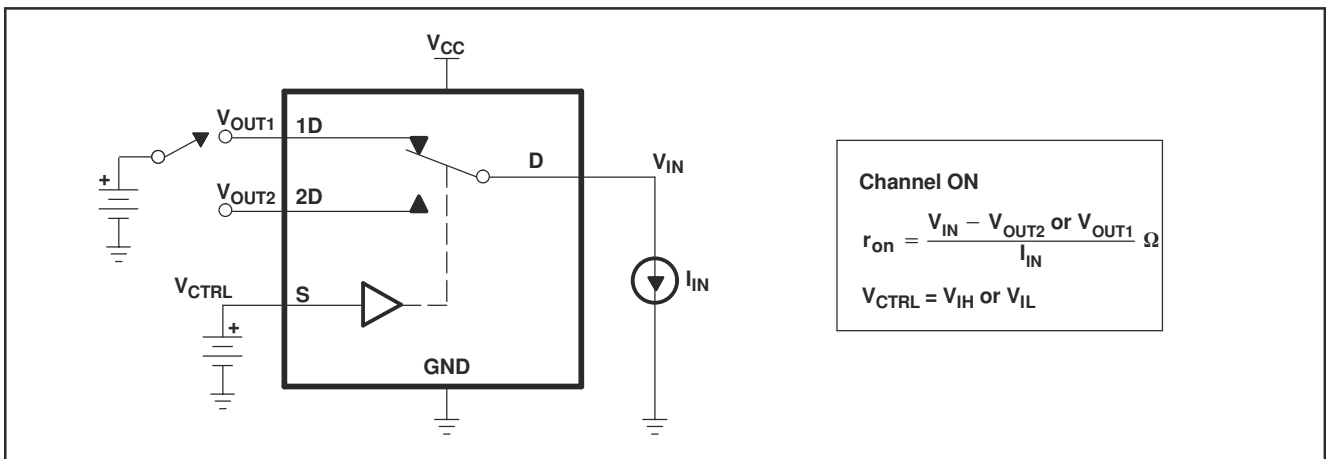

图 6-9. Capacitance

7 Detailed Description

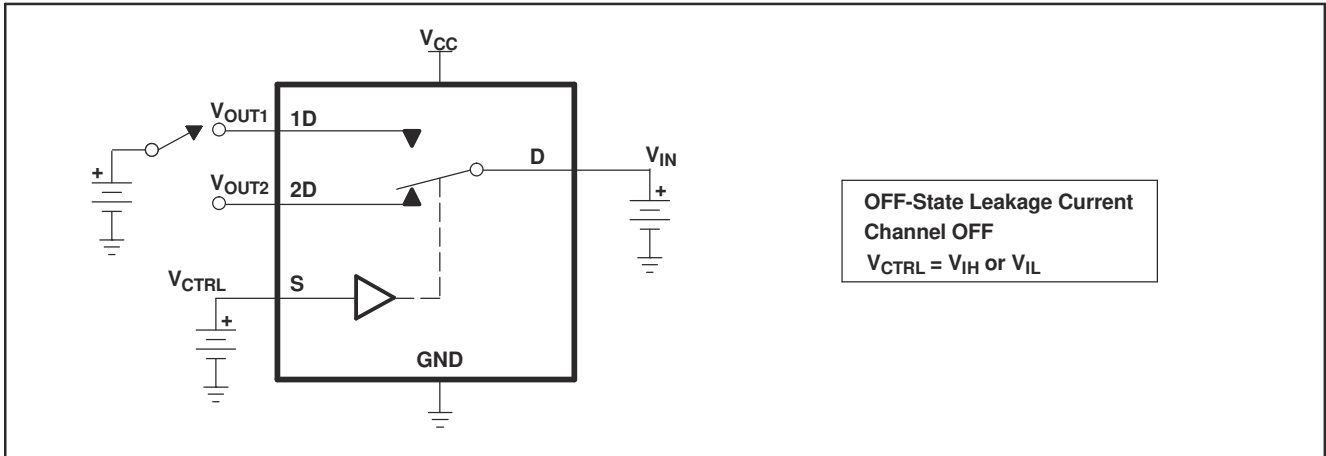
7.1 Overview

The TS3USB221A device is a 2-channel SPDT switch specially designed for the switching of high-speed USB 2.0 signals in handset and consumer applications, such as cell phones, digital cameras, and notebooks with hubs or controllers with limited USB I/Os. The wide bandwidth (900MHz) of this switch allows signals to pass with minimum edge and phase distortion. The device multiplexes differential outputs from a USB host device to one of two corresponding outputs. The switch is bidirectional and offers little or no attenuation of the high-speed signals at the outputs. The device also has a low power mode that can reduce the power consumption to 1 μ A for portable applications with a battery or limited power budget.

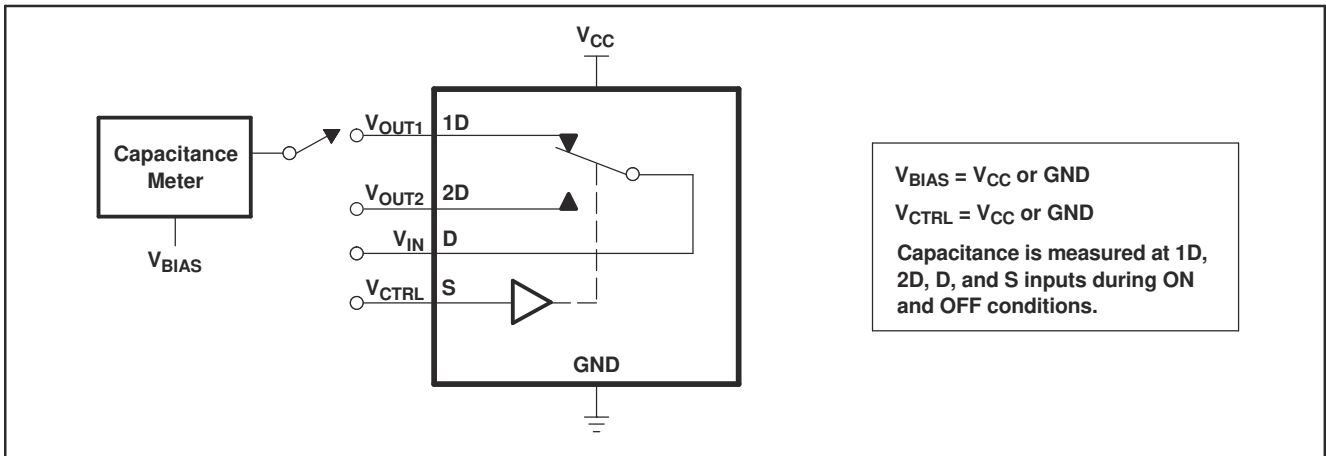
The device is designed for low bit-to-bit skew and high channel-to-channel noise isolation, and is compatible with various standards, such as high-speed USB 2.0 (480Mbps).

The TS3USB221A device integrates ESD protection cells on all pins, is available in a tiny μ QFN package (2mm \times 1.5mm) and is characterized over the free air temperature range from -40°C to 85°C.

7.2 Functional Block Diagram

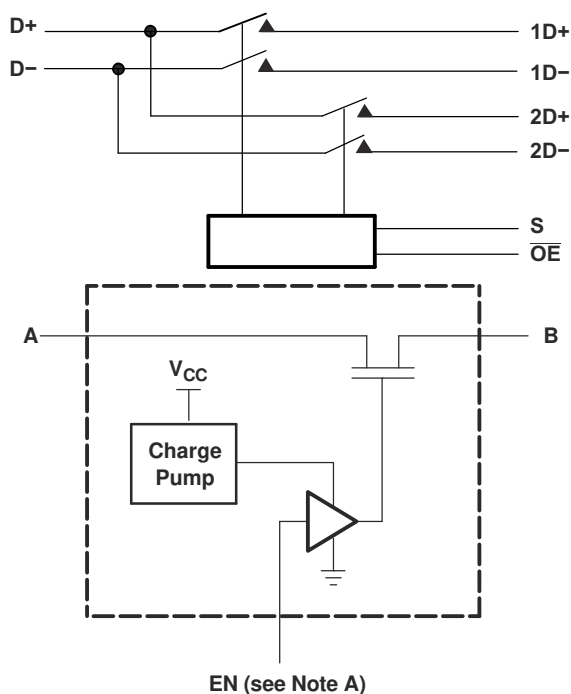

A. EN is the internal enable signal applied to the switch.

图 7-1. Simplified Schematic of Each FET Switch (SW)

7.3 Feature Description

7.3.1 Low Power Mode

The TS3USB221A has a low power mode that reduces the power consumption to 1 μ A while the device is not in use. To put the device in low power mode and disable the switch, the bus-switch enable pin \overline{OE} must be supplied with a logic "High" signal.

7.4 Device Functional Modes

表 7-1. Truth Table

S	\overline{OE}	FUNCTION
X	H	Disconnect
L	L	D = 1D
H	L	D = 2D

8 Application and Implementation

备注

以下应用部分中的信息不属于 TI 器件规格的范围，TI 不担保其准确性和完整性。TI 的客户应负责确定器件是否适用于其应用。客户应验证并测试其设计，以确保系统功能。

8.1 Application Information

There are many USB applications in which the USB hubs or controllers have a limited number of USB I/Os. The TS3USB221A can effectively expand the limited USB I/Os by switching between multiple USB buses and interface with the buses on a single USB hub or controller.

8.2 Typical Application



图 8-1. Application Schematic

8.2.1 Design Requirements

Follow the design requirements of the USB 1.0, 1.1, and 2.0 standards.

TI recommends that the digital control pins S and \overline{OE} be pulled up to V_{CC} or down to GND to avoid undesired switch positions that can result from the floating pin.

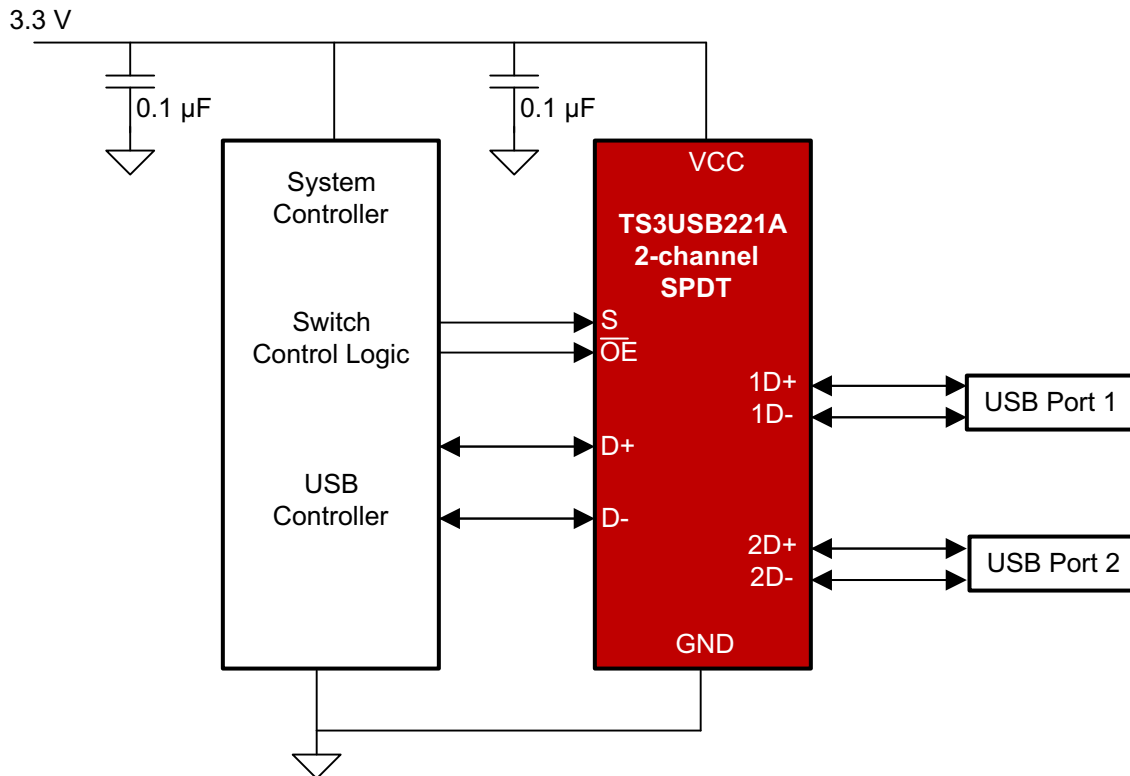
8.2.2 Detailed Design Procedure

The TS3USB221A can operate properly without any external components. However, TI recommends to connect unused pins to ground through a $50\ \Omega$ resistor to prevent signal reflections back into the device.

8.2.3 Application Curves



图 8-2. Eye Pattern: 480Mbps USB Signal With No Switch (Through Path)



图 8-3. Eye Pattern: 480Mbps USB Signal With Switch NC Path

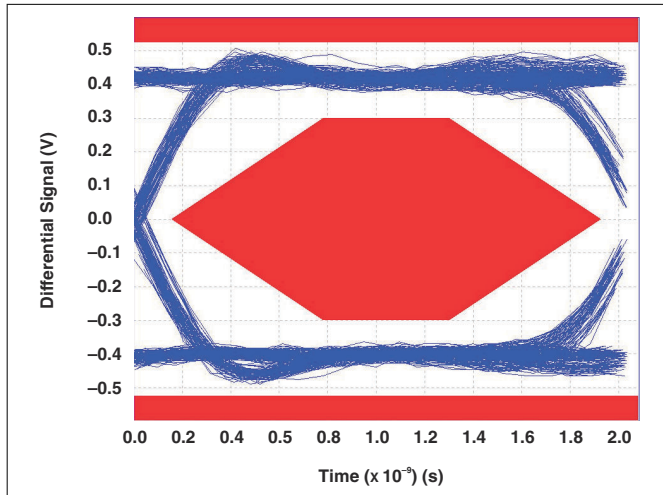

图 8-4. Eye Pattern: 480Mbps USB Signal With Switch NO Path

8.3 Power Supply Recommendations

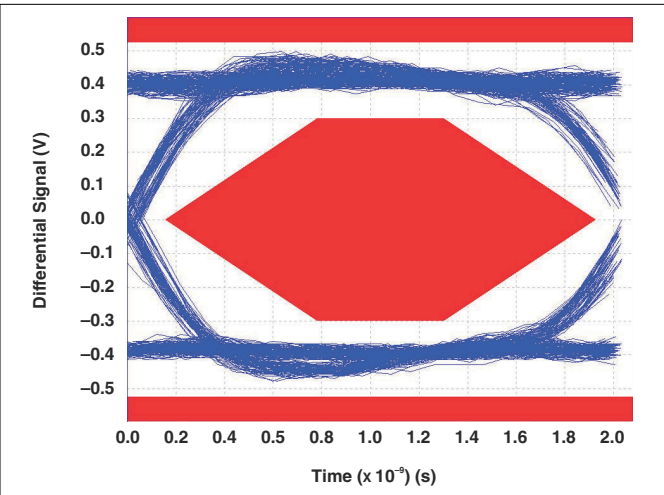
Make sure the power to the device is supplied through the VCC pin and follows the USB 1.0, 1.1, and 2.0 standards. A bypass capacitor is recommended to be placed as close to the supply pin VCC to help smooth out lower frequency noise to provide better load regulation across the frequency spectrum.

8.4 Layout

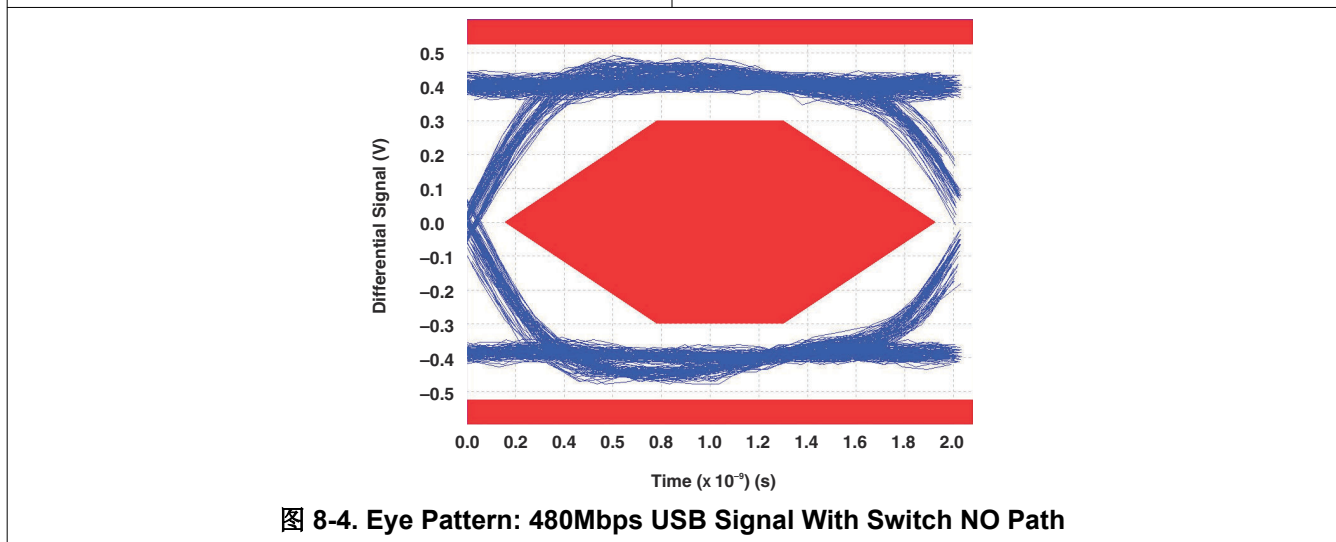
8.4.1 Layout Guidelines

Place supply bypass capacitors as close to VCC pin as possible and avoid placing the bypass caps near the D+/D⁻ traces.

Make sure the high speed D+/D⁻ trace lengths match and are no more than 4 inches; otherwise, the eye diagram performance can degrade. A high-speed USB connection is made through a shielded, twisted pair cable with a differential characteristic impedance. In layout, make sure the impedance of D+ and D⁻ traces match the cable characteristic differential impedance for optimal performance.

Route the high-speed USB signals using a minimum of vias and corners to reduce signal reflections and impedance changes. When a via must be used, increase the clearance size around the via to minimize the capacitance. Each via introduces discontinuities in the transmission line of the signal and increases the chance of picking up interference from the other layers of the board. Be careful when designing test points on twisted pair lines; through-hole pins are not recommended.

When it becomes necessary to turn 90°, use two 45° turns or an arc instead of making a single 90° turn. This reduces reflections on the signal traces by minimizing impedance discontinuities.

Do not route USB traces under or near crystals, oscillators, clock signal generators, switching regulators, mounting holes, magnetic devices or ICs that use or duplicate clock signals.

Avoid stubs on the high-speed USB signals because stubs cause signal reflections. If a stub is unavoidable, keep the stub less than 200mm.

Route all high-speed USB signal traces over continuous planes (VCC or GND), with no interruptions.

Avoid crossing over anti-etch, commonly found with plane splits.

Due to high frequencies associated with the USB, a printed circuit board with at least four layers is recommended; two signal layers separated by a ground and power layer as shown in [图 8-5](#).



图 8-5. Four-Layer Board Stack-Up

Make sure the majority of signal traces run on a single layer, preferably Signal 1. Make sure the GND plane, which is solid with no cuts, is immediately next to this layer. Avoid running signal traces across a split in the ground or power plane. When running across split planes is unavoidable, sufficient decoupling must be used. Minimizing the number of signal vias reduces EMI by reducing inductance at high frequencies.

8.4.2 Layout Example

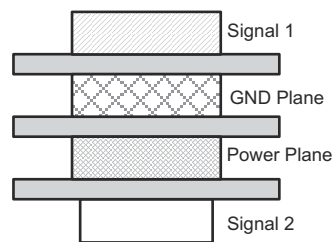

图 8-6. Package Layout Diagram

9 Device and Documentation Support

9.1 接收文档更新通知

要接收文档更新通知，请导航至 [ti.com](https://www.ti.com) 上的器件产品文件夹。点击 [通知](#) 进行注册，即可每周接收产品信息更改摘要。有关更改的详细信息，请查看任何已修订文档中包含的修订历史记录。

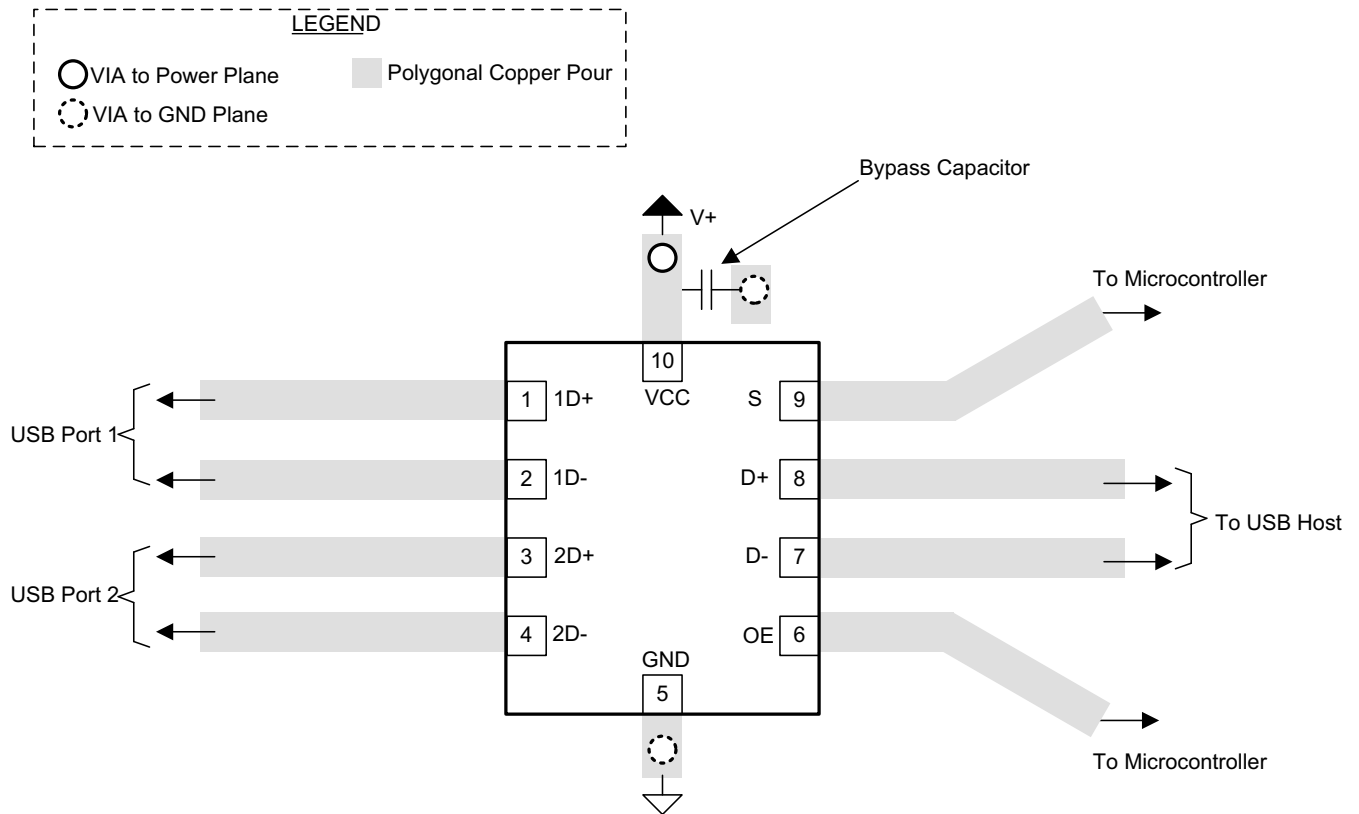
9.2 支持资源

[TI E2E™ 中文支持论坛](#) 是工程师的重要参考资料，可直接从专家处获得快速、经过验证的解答和设计帮助。搜索现有解答或提出自己的问题，获得所需的快速设计帮助。

链接的内容由各个贡献者“按原样”提供。这些内容并不构成 TI 技术规范，并且不一定反映 TI 的观点；请参阅 TI 的 [使用条款](#)。

9.3 Trademarks

TI E2E™ is a trademark of Texas Instruments.

所有商标均为其各自所有者的财产。

9.4 静电放电警告



静电放电 (ESD) 会损坏这个集成电路。德州仪器 (TI) 建议通过适当的预防措施处理所有集成电路。如果不遵守正确的处理和安装程序，可能会损坏集成电路。

ESD 的损坏小至导致微小的性能降级，大至整个器件故障。精密的集成电路可能更容易受到损坏，这是因为非常细微的参数更改都可能会导致器件与其发布的规格不相符。

9.5 术语表

[TI 术语表](#) 本术语表列出并解释了术语、首字母缩略词和定义。

10 Revision History

注：以前版本的页码可能与当前版本的页码不同

Changes from Revision B (July 2024) to Revision C (October 2024)	Page
• 将 <i>特性</i> 要点从 $R_{ON} = 6\ \omega$ (最大值) 更改为 $R_{ON} = 6\ \Omega$ (最大值)	1
• 将 <i>特性</i> 要点从 $\delta r_{ON} = 0.2\ \omega$ (典型值) 更改为 $\Delta r_{ON} = 0.2\ \Omega$ (典型值)	1

Changes from Revision A (February 2015) to Revision B (July 2024)	Page
• 更新了整个文档中的表格、图和交叉参考的编号格式.....	1
• 更新了 <i>特性</i> 部分中的 ESD 性能测试条件.....	1
• Changed CDM test conditions in the ESD Ratings table from: per JEDEC specification JESD22-C101 to: per ANSI/ESDA/JEDEC JS-002.....	4
• Added footnote to the V_{IO} parameter in the <i>Recommended Operating Conditions</i> table.....	4
• Changed RSE (UQFN) junction-to-ambient thermal resistance value from: 179.7°C/W to: 204.8°C/W.....	5
• Changed RSE (UQFN) junction-to-case (top) thermal resistance value from: 107.9°C/W to: 118.1°C/W.....	5
• Changed RSE (UQFN) junction-to-board thermal resistance value from: 100.7°C/W to: 121.5°C/W.....	5
• Changed RSE (UQFN) junction-to-top characterization parameter value from: 7.1°C/W to: 13.9°C/W.....	5
• Changed RSE (UQFN) junction-to-board characterization parameter value from: 100.0°C/W to: 121.2°C/W.....	5
• Changed the V_{IK} value in the <i>Electrical Characteristics</i> table from: - 1.8V maximum to: - 1.8V minimum.....	5
• Changed the <i>Typical Characteristics</i> section.....	7

Changes from Revision * (November 2008) to Revision A (February 2015)	Page
• 添加了“ESD 等级”表、“特性说明”部分、“器件功能模式”、“应用和实施”部分、“电源相关建议”部分、“布局”部分、“器件和文档支持”部分以及“机械、封装和可订购信息”部分.....	1
• 删除了数据表中的 <i>订购信息</i> 表。如需了解订购信息，请参阅 <i>机械、封装和可订购信息</i> 部分.....	1
• 将文档按全新 TI 数据表标准进行了更新.....	1

11 Mechanical, Packaging, and Orderable Information

The following pages include mechanical, packaging, and orderable information. This information is the most current data available for the designated devices. This data is subject to change without notice and revision of this document. For browser-based versions of this data sheet, refer to the left-hand navigation.

PACKAGING INFORMATION

Orderable part number	Status (1)	Material type (2)	Package Pins	Package qty Carrier	RoHS (3)	Lead finish/ Ball material (4)	MSL rating/ Peak reflow (5)	Op temp (°C)	Part marking (6)
TS3USB221ARSER	Active	Production	UQFN (RSE) 10	3000 LARGE T&R	Yes	NIPDAU	Level-1-260C-UNLIM	-40 to 85	(LH7, LHH, LHO, LHR, LHV)
TS3USB221ARSER.A	Active	Production	UQFN (RSE) 10	3000 LARGE T&R	Yes	NIPDAU	Level-1-260C-UNLIM	-40 to 85	(LH7, LHH, LHO, LHR, LHV)
TS3USB221ARSER.B	Active	Production	UQFN (RSE) 10	3000 LARGE T&R	Yes	NIPDAU	Level-1-260C-UNLIM	-40 to 85	(LH7, LHH, LHO, LHR, LHV)
TS3USB221ARSERG4	Active	Production	UQFN (RSE) 10	3000 LARGE T&R	Yes	NIPDAU	Level-1-260C-UNLIM	-40 to 85	(LH7, LHH, LHO, LHR, LHV)

(1) **Status:** For more details on status, see our [product life cycle](#).

(2) **Material type:** When designated, preproduction parts are prototypes/experimental devices, and are not yet approved or released for full production. Testing and final process, including without limitation quality assurance, reliability performance testing, and/or process qualification, may not yet be complete, and this item is subject to further changes or possible discontinuation. If available for ordering, purchases will be subject to an additional waiver at checkout, and are intended for early internal evaluation purposes only. These items are sold without warranties of any kind.

(3) **RoHS values:** Yes, No, RoHS Exempt. See the [TI RoHS Statement](#) for additional information and value definition.

(4) **Lead finish/Ball material:** Parts may have multiple material finish options. Finish options are separated by a vertical ruled line. Lead finish/Ball material values may wrap to two lines if the finish value exceeds the maximum column width.

(5) **MSL rating/Peak reflow:** The moisture sensitivity level ratings and peak solder (reflow) temperatures. In the event that a part has multiple moisture sensitivity ratings, only the lowest level per JEDEC standards is shown. Refer to the shipping label for the actual reflow temperature that will be used to mount the part to the printed circuit board.

(6) **Part marking:** There may be an additional marking, which relates to the logo, the lot trace code information, or the environmental category of the part.

Multiple part markings will be inside parentheses. Only one part marking contained in parentheses and separated by a "-" will appear on a part. If a line is indented then it is a continuation of the previous line and the two combined represent the entire part marking for that device.

Important Information and Disclaimer: The information provided on this page represents TI's knowledge and belief as of the date that it is provided. TI bases its knowledge and belief on information provided by third parties, and makes no representation or warranty as to the accuracy of such information. Efforts are underway to better integrate information from third parties. TI has taken and continues to take reasonable steps to provide representative and accurate information but may not have conducted destructive testing or chemical analysis on incoming materials and chemicals. TI and TI suppliers consider certain information to be proprietary, and thus CAS numbers and other limited information may not be available for release.

In no event shall TI's liability arising out of such information exceed the total purchase price of the TI part(s) at issue in this document sold by TI to Customer on an annual basis.

OTHER QUALIFIED VERSIONS OF TS3USB221A :

- Automotive : [TS3USB221A-Q1](#)

NOTE: Qualified Version Definitions:

- Automotive - Q100 devices qualified for high-reliability automotive applications targeting zero defects

TAPE AND REEL INFORMATION

QUADRANT ASSIGNMENTS FOR PIN 1 ORIENTATION IN TAPE



*All dimensions are nominal

Device	Package Type	Package Drawing	Pins	SPQ	Reel Diameter (mm)	Reel Width W1 (mm)	A0 (mm)	B0 (mm)	K0 (mm)	P1 (mm)	W (mm)	Pin1 Quadrant
TS3USB221ARSER	UQFN	RSE	10	3000	180.0	8.4	1.68	2.13	0.76	4.0	8.0	Q1

TAPE AND REEL BOX DIMENSIONS

*All dimensions are nominal

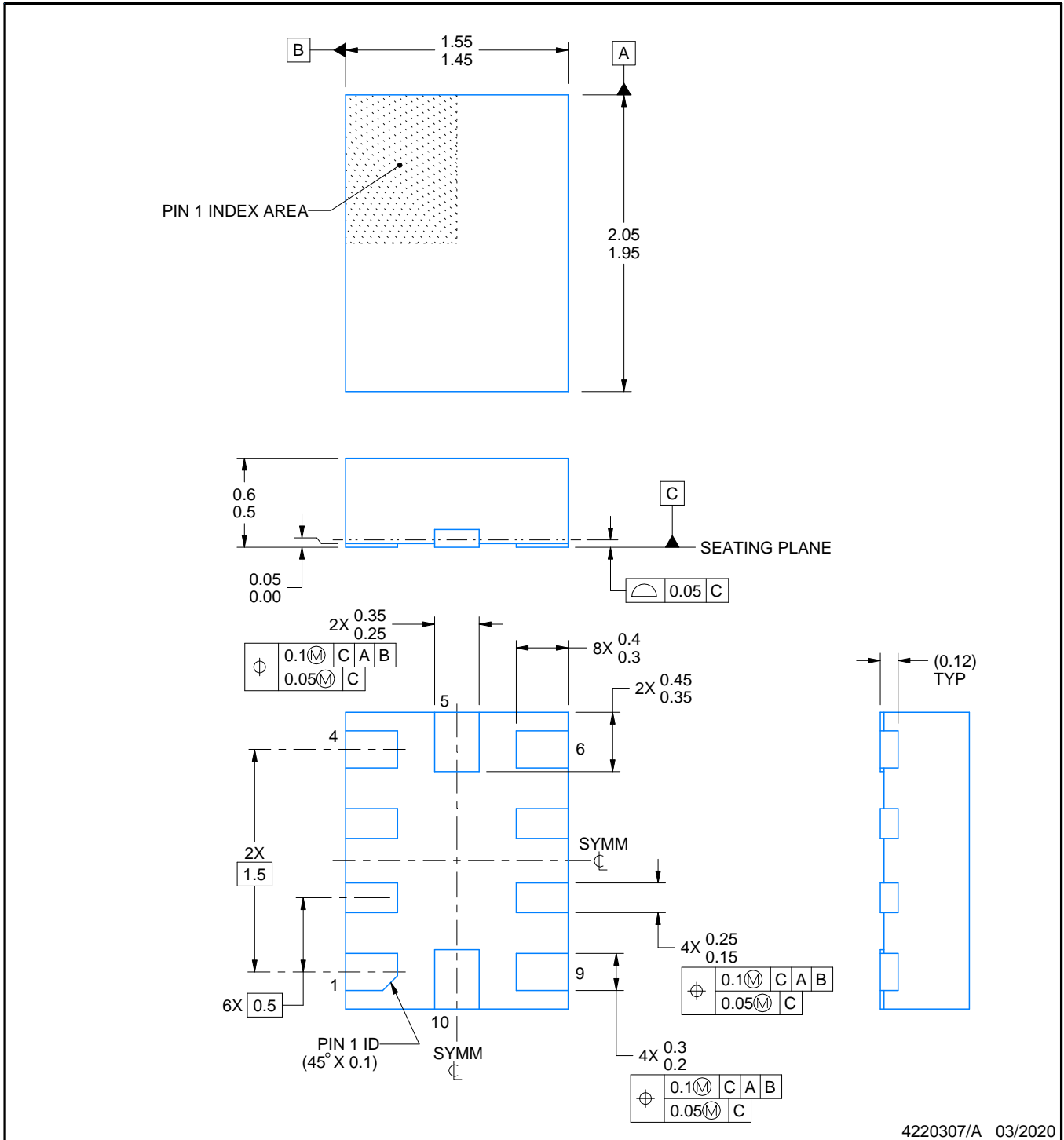
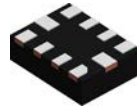
Device	Package Type	Package Drawing	Pins	SPQ	Length (mm)	Width (mm)	Height (mm)
TS3USB221ARSER	UQFN	RSE	10	3000	210.0	185.0	35.0



NOTES:

1. All linear dimensions are in millimeters. Any dimensions in parenthesis are for reference only. Dimensioning and tolerancing per ASME Y14.5M.
2. This drawing is subject to change without notice.

EXAMPLE BOARD LAYOUT

RSE0010A

UQFN - 0.6 mm max height

PLASTIC QUAD FLATPACK - NO LEAD

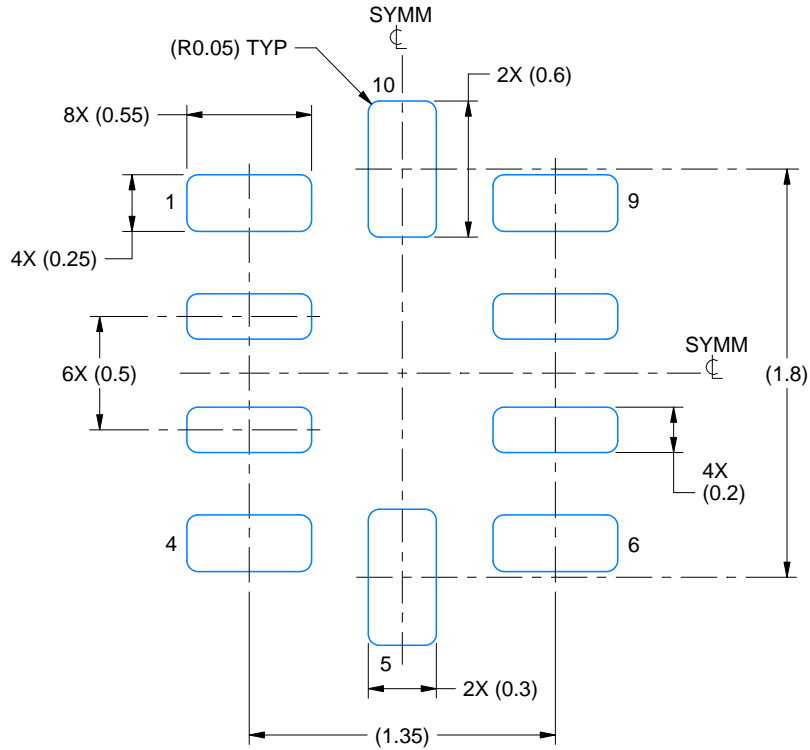

LAND PATTERN EXAMPLE
EXPOSED METAL SHOWN
SCALE:30X

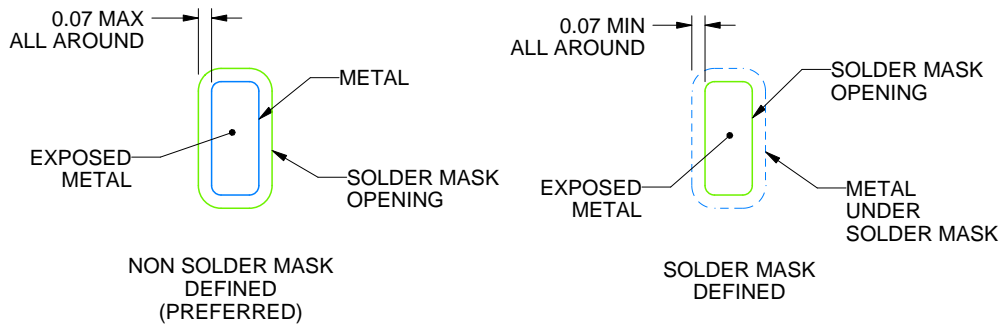

SOLDER MASK DETAILS
NOT TO SCALE

4220307/A 03/2020

NOTES: (continued)

3. For more information, see Texas Instruments literature number SLUA271 (www.ti.com/lit/slua271).

重要通知和免责声明

TI“按原样”提供技术和可靠性数据（包括数据表）、设计资源（包括参考设计）、应用或其他设计建议、网络工具、安全信息和其他资源，不保证没有瑕疵且不做任何明示或暗示的担保，包括但不限于对适销性、与某特定用途的适用性或不侵犯任何第三方知识产权的暗示担保。

这些资源可供使用 TI 产品进行设计的熟练开发人员使用。您将自行承担以下全部责任：(1) 针对您的应用选择合适的 TI 产品，(2) 设计、验证并测试您的应用，(3) 确保您的应用满足相应标准以及任何其他安全、安保法规或其他要求。

这些资源如有变更，恕不另行通知。TI 授权您仅可将这些资源用于研发本资源所述的 TI 产品的相关应用。严禁以其他方式对这些资源进行复制或展示。您无权使用任何其他 TI 知识产权或任何第三方知识产权。对于因您对这些资源的使用而对 TI 及其代表造成的任何索赔、损害、成本、损失和债务，您将全额赔偿，TI 对此概不负责。

TI 提供的产品受 [TI 销售条款](#)、[TI 通用质量指南](#) 或 [ti.com](#) 上其他适用条款或 TI 产品随附的其他适用条款的约束。TI 提供这些资源并不会扩展或以其他方式更改 TI 针对 TI 产品发布的适用的担保或担保免责声明。除非德州仪器 (TI) 明确将某产品指定为定制产品或客户特定产品，否则其产品均为按确定价格收入目录的标准通用器件。

TI 反对并拒绝您可能提出的任何其他或不同的条款。

版权所有 © 2026，德州仪器 (TI) 公司

最后更新日期：2025 年 10 月