

具有 ±15kV ESD 保护功能的 TRIS3232 3V 至 5.5V 多通道 RS-232 线路驱动器和接收器

1 特性

- RS-232 总线终端 ESD 保护大于 ±15kV 人体放电模型 (HBM)
- 符合或超出 TIA/EIA-232-F 和 ITU V.28 标准的要求
- 由 3V 至 5.5V V_{CC} 电源供电
- 运行速率高达 250kbps
- 两个驱动器和两个接收器
- 低电源电流：300 μA (典型值)
- 外部电容器：4 × 0.1 μF
- 接受 5V 逻辑输入及 3.3V 电源
- 备选高速端子兼容器件 (1Mbps)
 - SN65C3232 (-40°C 至 85°C)
 - SN75C3232 (0°C 至 70°C)

2 应用

- 工业 PC
- 有线网络
- 数据中心和企业级计算
- 电池供电型系统
- 笔记本电脑
- 便携式计算机
- 掌上电脑
- 手持设备

3 说明

TRIS3232 器件由两个线路驱动器、两个线路接收器和一个双路电荷泵电路组成，具有端子间 (串行端口连接端子，包括 GND) ±15kV ESD 保护。该器件符合 TIA/EIA-232-F 的要求并在异步通信控制器与串行端口连接器之间提供电气接口。电荷泵和四个小型外部电容器支持

通过一个 3V 至 5.5V 电源供电运行。这些器件以高达 250kbps 的数据信号传输速率和最大值为 30V/ μs 的驱动器输出压摆率运行。

器件信息

器件型号	封装 ⁽¹⁾	封装尺寸 (标称值)
TRIS3232	SOIC (16)	9.90mm x 3.91mm
	SSOP (16)	6.20mm x 5.30mm
	SOIC 宽 (16)	10.30mm x 7.50mm
	TSSOP (16)	5.00mm × 4.40mm

(1) 如需了解所有可用封装，请参阅数据表末尾的可订购产品附录。

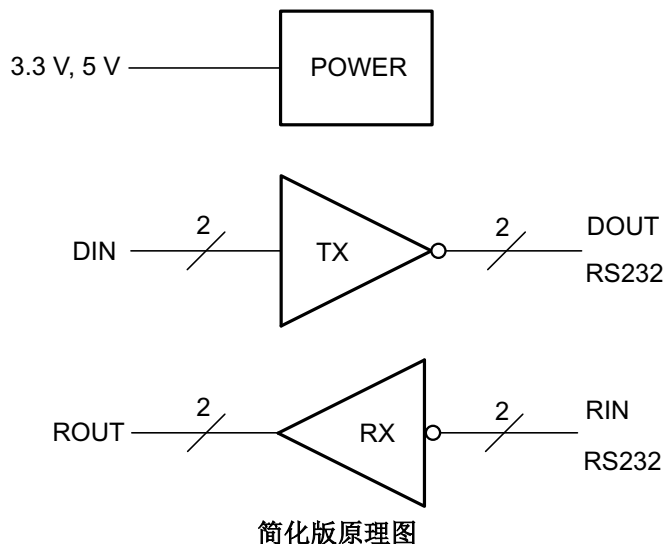

Table of Contents

1 特性	1	8.2 Functional Block Diagram.....	9
2 应用	1	8.3 Feature Description.....	9
3 说明	1	8.4 Device Functional Modes.....	10
4 Revision History	2	9 Application and Implementation	11
5 Pin Configuration and Functions	3	9.1 Application Information.....	11
6 Specifications	4	9.2 Typical Application.....	11
6.1 Absolute Maximum Ratings.....	4	10 Power Supply Recommendations	12
6.2 ESD Ratings.....	4	11 Layout	13
6.3 Recommended Operating Conditions.....	4	11.1 Layout Guidelines.....	13
6.4 Thermal Information.....	5	11.2 Layout Example.....	13
6.5 Electrical Characteristics—Device.....	5	12 Device and Documentation Support	14
6.6 Electrical Characteristics—Driver.....	5	12.1 接收文档更新通知.....	14
6.7 Electrical Characteristics—Receiver.....	6	12.2 支持资源.....	14
6.8 Switching Characteristics.....	6	12.3 Trademarks.....	14
6.9 Typical Characteristics.....	7	12.4 静电放电警告.....	14
7 Parameter Measurement Information	8	12.5 术语表.....	14
8 Detailed Description	9	13 Mechanical, Packaging, and Orderable Information	14
8.1 Overview.....	9		

4 Revision History

注：以前版本的页码可能与当前版本的页码不同

Changes from Revision A (July 2015) to Revision B (June 2021)	Page
• 添加了 <i>应用</i> ：工业 PC、有线网络、数据中心和企业级计算.....	1
• Added additional thermal parameters for all packages in <i>Thermal Information table</i>	5

Changes from Revision * (July 2007) to Revision A (June 2015)	Page
• 更改了 <i>引脚功能表</i> 、 <i>ESD 等级表</i> 、 <i>热性能信息表</i> 、 <i>典型特性部分</i> 、 <i>详细说明部分</i> 、 <i>电源建议</i> 和 <i>布局部分</i> 、 <i>器件和文档支持</i> 和 <i>机械、封装和可订购信息</i>	1
• Deleted <i>Ordering Information table</i>	3

5 Pin Configuration and Functions



图 5-1. D, DB, DW, PW Packages 16-Pin SOIC, SSOP, SOIC (Wide), TSSOP Top View

表 5-1. Pin Functions

PIN		TYPE	DESCRIPTION
NAME	NO.		
C1+	1	—	Positive lead of C1 capacitor
C1 -	3	—	Negative lead of C1 capacitor
C2+	4	—	Positive lead of C2 capacitor
C2 -	5	—	Negative lead of C2 capacitor
DIN1	11	I	Logic data input (from UART)
DIN2	10	I	Logic data input (from UART)
DOUT1	14	O	RS232 line data output (to remote RS232 system)
DOUT2	7	O	RS232 line data output (to remote RS232 system)
GND	15	—	Ground
RIN1	13	I	RS232 line data input (from remote RS232 system)
RIN2	8	I	RS232 line data input (from remote RS232 system)
ROUT1	12	O	Logic data output (to UART)
ROUT2	9	O	Logic data output (to UART)
V+	2	O	Positive charge pump output for storage capacitor only
V -	6	O	Negative charge pump output for storage capacitor only
V _{CC}	16	—	Supply Voltage, Connect to external 3-V to 5.5-V power supply

6 Specifications

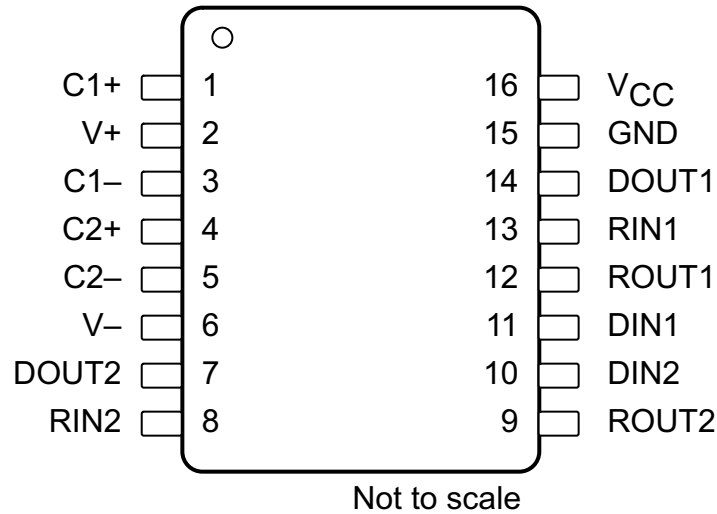
6.1 Absolute Maximum Ratings

over operating free-air temperature range (unless otherwise noted) ⁽¹⁾

		MIN	MAX	UNIT	
V _{CC}	Supply voltage ⁽²⁾	- 0.3	6	V	
V ₊	Positive output supply voltage ⁽²⁾	- 0.3	7	V	
V ₋	Negative output supply voltage ⁽²⁾	- 7	0.3	V	
V ₊ - V ₋	Supply voltage difference ⁽²⁾		13	V	
V _I	Input voltage	Drivers	- 0.3	6	V
		Receivers	- 25	25	
V _O	Output voltage	Drivers	- 13.2	13.2	V
		Receivers	- 0.3	V _{CC} + 0.3	
T _J	Operating virtual junction temperature		150	°C	
T _{stg}	Storage temperature	- 65	150	°C	

- (1) Operation outside the *Absolute Maximum Ratings* may cause permanent device damage. *Absolute Maximum Ratings* do not imply functional operation of the device at these or any other conditions beyond those listed under *Recommended Operating Conditions*. If used outside the *Recommended Operating Conditions* but within the *Absolute Maximum Ratings*, the device may not be fully functional, and this may affect device reliability, functionality, performance, and shorten the device lifetime.
- (2) All voltages are with respect to network GND.

6.2 ESD Ratings

		VALUE	UNIT	
V _(ESD)	Electrostatic discharge	Human body model (HBM), per ANSI/ESDA/JEDEC JS-001 RIN , DOUT, and GND pins ⁽¹⁾	±15000	V
		Human body model (HBM), per ANSI/ESDA/JEDEC JS-001 All other pins ⁽¹⁾	±3000	
		Charged device model (CDM), per JEDEC specification JESD22-C101, all pins ⁽²⁾	±1000	

- (1) JEDEC document JEP155 states that 500-V HBM allows safe manufacturing with a standard ESD control process.
- (2) JEDEC document JEP157 states that 250-V CDM allows safe manufacturing with a standard ESD control process.

6.3 Recommended Operating Conditions

(see 图 9-1)⁽¹⁾

		MIN	NOM	MAX	UNIT	
V _{CC}	Supply voltage	V _{CC} = 3.3 V	3	3.3	3.6	V
		V _{CC} = 5 V	4.5	5	5.5	
V _{IH}	Driver high-level input voltage	DIN	V _{CC} = 3.3 V	2		V
			V _{CC} = 5 V	2.4		
V _{IL}	Driver low-level input voltage	DIN			0.8	V
V _I	Driver input voltage	DIN	0	5.5	V	
	Receiver input voltage	RIN	- 25	25		
T _A	Operating free-air temperature	TRS3232C	0	70	°C	
		TRS3232I	- 40	85	°C	

- (1) Test conditions are C1 - C4 = 0.1 μF at V_{CC} = 3.3 V ± 0.3 V; C1 = 0.047 μF, C2 - C4 = 0.33 μF at V_{CC} = 5 V ± 0.5 V.

6.4 Thermal Information

THERMAL METRIC ⁽¹⁾	TRS3232				UNIT
	D (SOIC)	DB (SSOP)	DW (SOIC-wide)	PW (TSSOP)	
	16 PINS	16 PINS	16 PINS	16 PINS	
$R_{\theta JA}$ Junction-to-ambient thermal resistance	73	82	57	108	°C/W
$R_{\theta JC(top)}$ Junction-to-case (bottom) thermal resistance	38.5	45.8	32.4	39	°C/W
$R_{\theta JB}$ Junction-to-board thermal resistance	36.3	44.6	31.9	54.4	°C/W
ψ_{JT} Junction-to-top characterization parameter	8.0	11.1	8.4	3.3	°C/W
ψ_{JB} Junction-to-board characterization parameter	36.0	44	31.5	53.8	°C/W
$R_{\theta JC(bot)}$ Junction-to-case (bottom) thermal resistance	N/A	N/A	N/A	N/A	°C/W

(1) For more information about traditional and new thermal metrics, see the *Semiconductor and IC Package Thermal Metrics* application report (SPRA953).

6.5 Electrical Characteristics—Device

over recommended ranges of supply voltage and operating free-air temperature (unless otherwise noted)⁽²⁾ (see 图 9-1)

PARAMETER	TEST CONDITIONS	MIN	TYP ⁽¹⁾	MAX	UNIT
I_{CC} Supply current	No load, $V_{CC} = 3.3 \text{ V to } 5 \text{ V}$		0.3	1	mA

(1) All typical values are at $V_{CC} = 3.3 \text{ V}$ or $V_{CC} = 5 \text{ V}$, and $T_A = 25^\circ\text{C}$.

(2) Test conditions are $C1 - C4 = 0.1 \mu\text{F}$ at $V_{CC} = 3.3 \text{ V} \pm 0.3 \text{ V}$; $C1 = 0.047 \mu\text{F}$, $C2 - C4 = 0.33 \mu\text{F}$ at $V_{CC} = 5 \text{ V} \pm 0.5 \text{ V}$.

6.6 Electrical Characteristics—Driver

over recommended ranges of supply voltage and operating free-air temperature (unless otherwise noted)⁽¹⁾ (see 图 9-1)

PARAMETER	TEST CONDITIONS	MIN	TYP ⁽²⁾	MAX	UNIT
V_{OH} High-level output voltage	D_{OUT} at $R_L = 3 \text{ k}\Omega$ to GND, $D_{IN} = \text{GND}$	5	5.4		V
V_{OL} Low-level output voltage	D_{OUT} at $R_L = 3 \text{ k}\Omega$ to GND, $D_{IN} = V_{CC}$	-5	-5.4		V
I_{IH} High-level input current	$V_I = V_{CC}$		± 0.01	± 1	μA
I_{IL} Low-level input current	V_I at GND		± 0.01	± 1	μA
I_{OS} ⁽³⁾ Short-circuit output current	$V_{CC} = 3.6 \text{ V}$ $V_O = 0 \text{ V}$		± 35	± 60	mA
	$V_{CC} = 5.5 \text{ V}$ $V_O = 0 \text{ V}$				
r_O Output resistance	$V_{CC} = 0 \text{ V}$, $V_+ = 0 \text{ V}$, and $V_- = 0 \text{ V}$ $V_O = \pm 2 \text{ V}$	300	10M		Ω

(1) Test conditions are $C1 - C4 = 0.1 \mu\text{F}$ at $V_{CC} = 3.3 \text{ V} \pm 0.3 \text{ V}$; $C1 = 0.047 \mu\text{F}$, $C2 - C4 = 0.33 \mu\text{F}$ at $V_{CC} = 5 \text{ V} \pm 0.5$

(2) All typical values are at $V_{CC} = 3.3 \text{ V}$ or $V_{CC} = 5 \text{ V}$, and $T_A = 25^\circ\text{C}$.

(3) Short-circuit durations should be controlled to prevent exceeding the device absolute power dissipation ratings, and not more than one output should be shorted at a time.

6.7 Electrical Characteristics—Receiver

over recommended ranges of supply voltage and operating free-air temperature (unless otherwise noted)⁽¹⁾ (see [Fig 9-1](#))

PARAMETER		TEST CONDITIONS	MIN	TYP ⁽²⁾	MAX	UNIT
V _{OH}	High-level output voltage	I _{OH} = - 1 mA	V _{CC} - 0.6	V _{CC} - 0.1		V
V _{OL}	Low-level output voltage	I _{OL} = 1.6 mA			0.4	V
V _{IT+}	Positive-going input threshold voltage	V _{CC} = 3.3 V		1.5	2.4	V
		V _{CC} = 5 V		1.8	2.4	
V _{IT-}	Negative-going input threshold voltage	V _{CC} = 3.3 V	0.6	1.2		V
		V _{CC} = 5 V	0.8	1.5		
V _{hys}	Input hysteresis (V _{IT+} - V _{IT-})			0.3		V
r _I	Input resistance	V _I = ±3 V to ±25 V	3	5	7	kΩ

(1) Test conditions are C1 - C4 = 0.1 μF at V_{CC} = 3.3 V ± 0.3 V; C1 = 0.047 μF, C2 - C4 = 0.33 μF at V_{CC} = 5 V ± 0.5 V.

(2) All typical values are at V_{CC} = 3.3 V or V_{CC} = 5 V, and T_A = 25°C.

6.8 Switching Characteristics

over recommended ranges of supply voltage and operating free-air temperature (unless otherwise noted)⁽¹⁾ (see [Fig 9-1](#))

PARAMETER		TEST CONDITIONS	MIN	TYP ⁽²⁾	MAX	UNIT
	Maximum data rate	R _L = 3 kΩ, One D _{OUT} switching,		150	250	kbps
		C _L = 1000 pF See Fig 7-1				
t _{sk(p)}	Driver Pulse skew ⁽³⁾	R _L = 3 kΩ to 7 kΩ, See Fig 7-2			300	ns
SR(tr)	Driver Slew rate, transition region (see Fig 7-1)	R _L = 3 kΩ to 7 kΩ, V _{CC} = 5 V	C _L = 150 to 1000 pF	6	30	V/μs
			C _L = 150 to 2500 pF	4	30	
t _{PLH}	Receiver Propagation delay time, low- to high-level output	C _L = 150 pF		300		ns
t _{PHL}	Receiver Propagation delay time, high- to low-level output			300		ns
t _{sk(p)}	Receiver Pulse skew ⁽¹⁾				300	

(1) Test conditions are C1 - C4 = 0.1 μF at V_{CC} = 3.3 V ± 0.3 V; C1 = 0.047 μF, C2 - C4 = 0.33 μF at V_{CC} = 5 V ± 0.5 V.

(2) All typical values are at V_{CC} = 3.3 V or V_{CC} = 5 V, and T_A = 25°C.

(3) Pulse skew is defined as |t_{PLH} - t_{PHL}| of each channel of the same device.

6.9 Typical Characteristics

$V_{CC} = 3.3\text{ V}$



图 6-1. DOUT V_{OH} vs Load Current, Both Drivers Loaded



图 6-2. DOUT V_{OL} vs Load Current, Both Drivers Loaded

7 Parameter Measurement Information

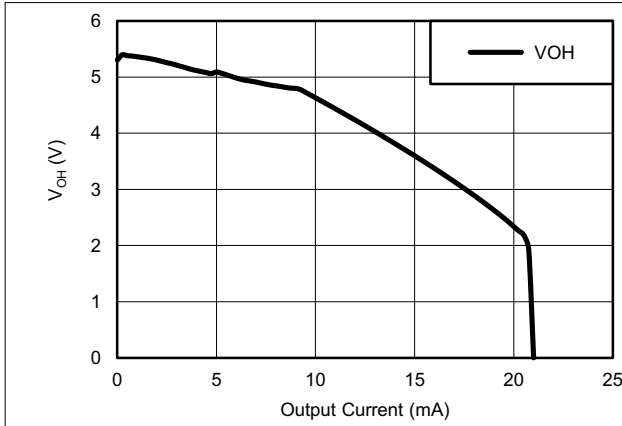

TEST CIRCUIT

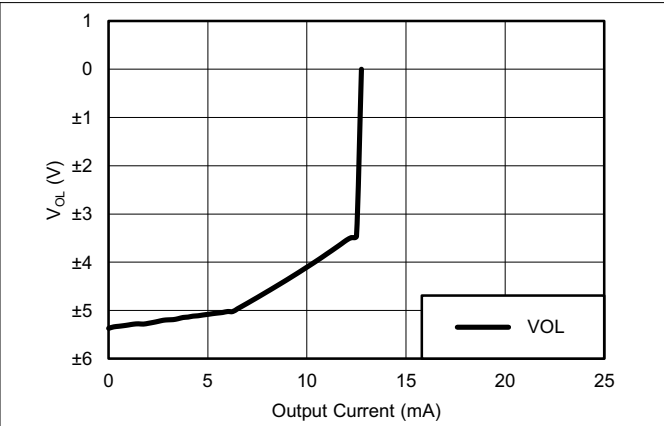
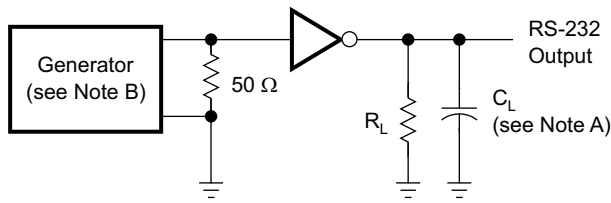
$$SR(tr) = \frac{6\text{ V}}{t_{THL} \text{ or } t_{TLH}}$$

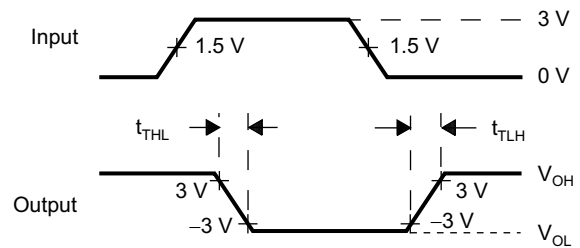

VOLTAGE WAVEFORMS

- A. C_L includes probe and jig capacitance.
- B. The pulse generator has the following characteristics: PRR = 250 kbps, $Z_O = 50\ \Omega$, 50% duty cycle, $t_r \leq 10\text{ ns}$, $t_f \leq 10\text{ ns}$.

图 7-1. Driver Slew Rate

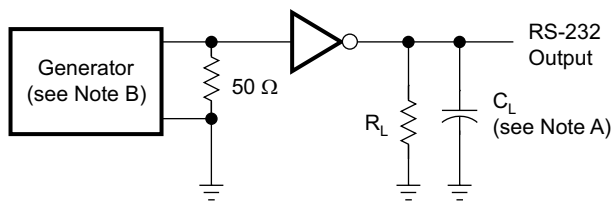

TEST CIRCUIT

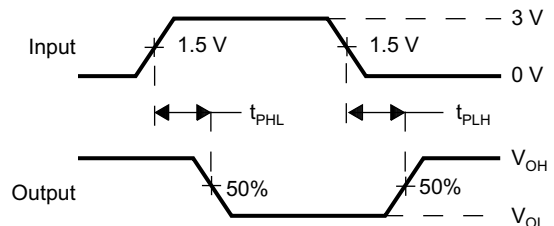

VOLTAGE WAVEFORMS

- A. C_L includes probe and jig capacitance.
- B. The pulse generator has the following characteristics: PRR = 250 kbps, $Z_O = 50\ \Omega$, 50% duty cycle, $t_r \leq 10\text{ ns}$, $t_f \leq 10\text{ ns}$.

图 7-2. Driver Pulse Skew

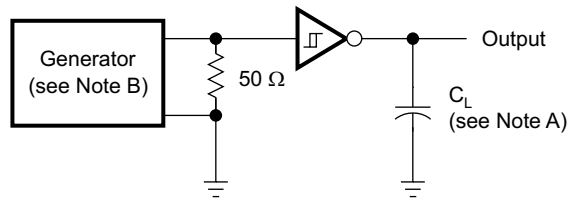

TEST CIRCUIT

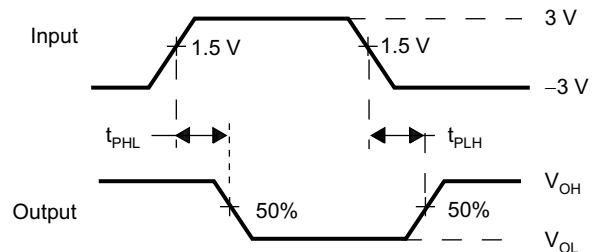

VOLTAGE WAVEFORMS

- A. C_L includes probe and jig capacitance.
- B. The pulse generator has the following characteristics: $Z_O = 50\ \Omega$, 50% duty cycle, $t_r \leq 10\text{ ns}$, $t_f \leq 10\text{ ns}$.

图 7-3. Receiver Propagation Delay Times

8 Detailed Description

8.1 Overview

The TRS3232 device consists of two line drivers, two line receivers, and a dual charge-pump circuit with ± 15 -kV ESD protection terminal to terminal (serial-port connection terminals, including GND). The device meets the requirements of TIA/EIA-232-F and provides the electrical interface between an asynchronous communication controller and the serial-port connector. The charge pump and four small external capacitors allow operation from one 3-V to 5.5-V supply. The device operates at data signaling rates up to 250 kbps and a maximum of $30\text{-V}/\mu\text{s}$ driver output slew rate. Outputs are protected against shorts to ground.

8.2 Functional Block Diagram

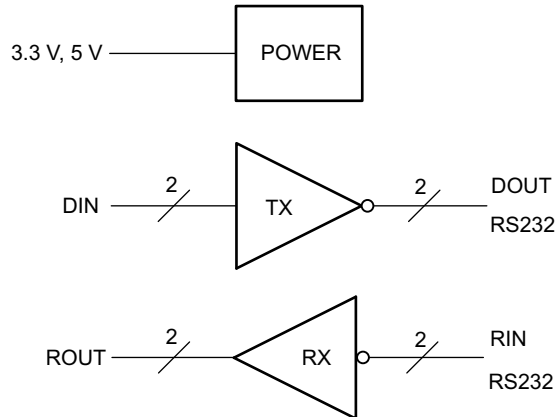

8.3 Feature Description

8.3.1 Power

The power block increases, inverts, and regulates voltage at V_+ and V_- pins using a charge pump that requires four external capacitors.

8.3.2 RS232 Driver

Two drivers interface the standard logic level to RS232 levels. Both DIN inputs must be valid high or low.

8.3.3 RS232 Receiver

Two receivers interface RS232 levels to standard logic levels. An open input results in a high output on ROUT. Each RIN input includes an internal standard RS232 load.

8.4 Device Functional Modes

表 8-1. Each Driver

INPUT DIN ⁽¹⁾	OUTPUT DOUT
L	H
H	L

(1) H = high level, L = low level

表 8-2. Each Receiver

INPUT RIN ⁽¹⁾	OUTPUT ROUT
L	H
H	L
Open	H

(1) H = high level, L = low level,
Open = input disconnected or connected driver off

8.4.1 V_{CC} Powered by 3 V to 5.5 V

The device is in normal operation.

8.4.2 V_{CC} Unpowered, V_{CC} = 0 V

When the TRIS3232 device is unpowered, it can be safely connected to an active remote RS232 device.

9 Application and Implementation

Note

以下应用部分中的信息不属于 TI 器件规格的范围，TI 不担保其准确性和完整性。TI 的客户应负责确定器件是否适用于其应用。客户应验证并测试其设计，以确保系统功能。

9.1 Application Information

The TRS3232 is designed to convert single-ended signals into RS232-compatible signals, and vice-versa.

This device can be used in any application where an RS232 line driver or receiver is required. One benefit of this device is its ESD protection, which helps protect other components on the board when the RS232 lines are tied to a physical connector.

9.2 Typical Application

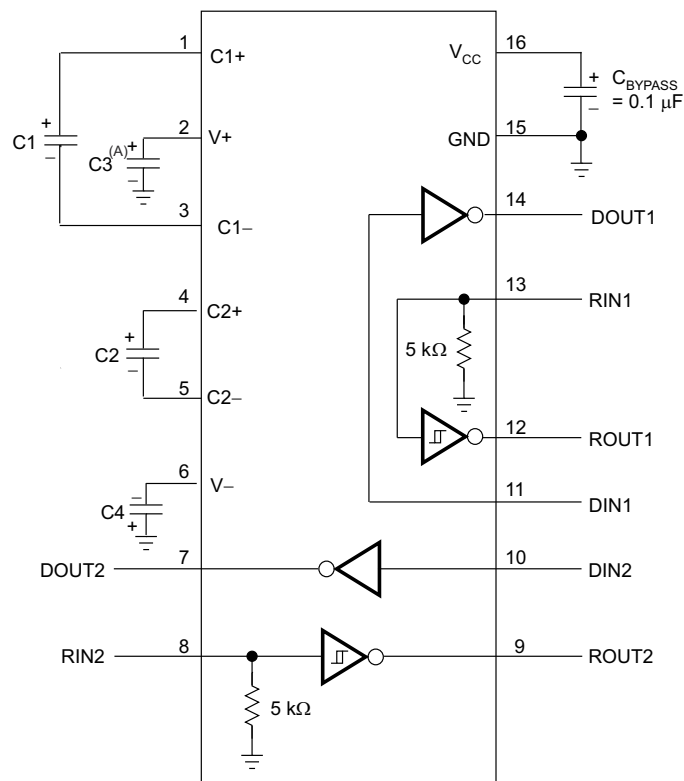

- A. C3 can be connected to V_{CC} or GND.
- B. Resistor values shown are nominal.
- C. Nonpolarized ceramic capacitors are acceptable. If polarized tantalum or electrolytic capacitors are used, they must be connected as shown.
- D. See 表 9-1 for capacitor values.

图 9-1. Typical Operating Circuit

9.2.1 Design Requirements

- Recommended V_{CC} is 3.3 V or 5 V
 - 3 V to 5.5 V is also possible
- Maximum recommended bit rate is 250 kbites

表 9-1. V_{CC} versus Capacitor Values

V_{CC}	C1	C2, C3, C4
3.3 V \pm 0.3 V	0.1 μ F	0.1 μ F
5 V \pm 0.5 V	0.047 μ F	0.33 μ F
3 V to 5.5 V	0.1 μ F	0.47 μ F

9.2.2 Detailed Design Procedure

For proper operation, add capacitors as shown in [图 9-1](#) 和 [表 9-1](#).

All DIN inputs must be connected to valid low or high logic levels.

Select capacitor values based on V_{CC} level for best performance.

9.2.3 Application Curve



图 9-2. 250 kbps Driver to Receiver Loopback Timing Waveform, V_{CC} = 3.3 V

10 Power Supply Recommendations

V_{CC} must be between 3 V and 5.5 V. Charge pump capacitors must be chosen using [表 9-1](#).

11 Layout

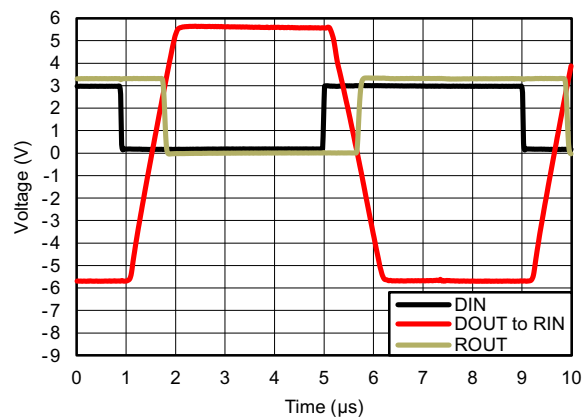
11.1 Layout Guidelines

Keep the external capacitor traces short. This is more important on C1 and C2 nodes that have the fastest rise and fall times.

11.2 Layout Example



图 11-1. Layout Diagram

12 Device and Documentation Support

12.1 接收文档更新通知

要接收文档更新通知，请导航至 ti.com 上的器件产品文件夹。点击 [订阅更新](#) 进行注册，即可每周接收产品信息更改摘要。有关更改的详细信息，请查看任何已修订文档中包含的修订历史记录。

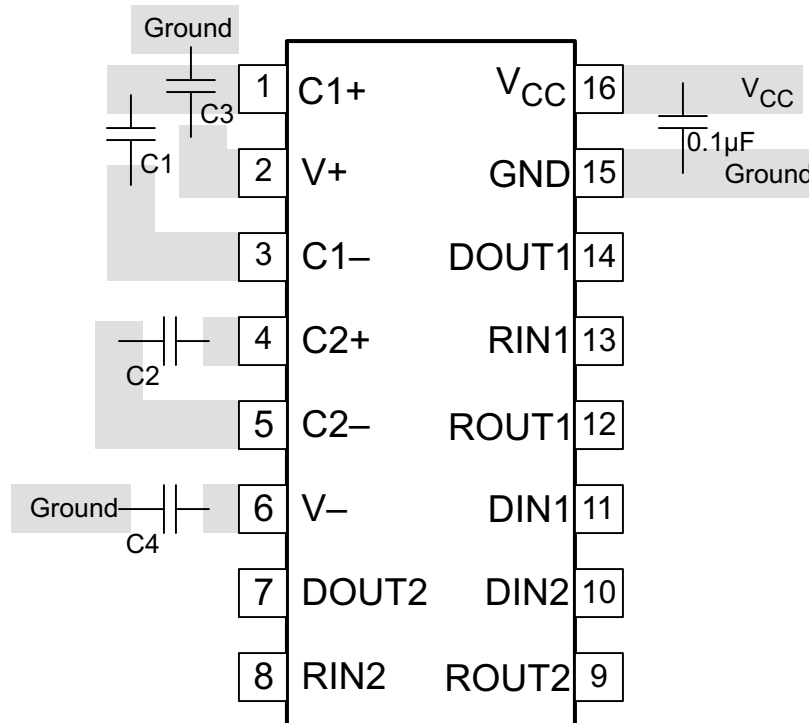
12.2 支持资源

[TI E2E™ 支持论坛](#) 是工程师的重要参考资料，可直接从专家获得快速、经过验证的解答和设计帮助。搜索现有解答或提出自己的问题可获得所需的快速设计帮助。

链接的内容由各个贡献者“按原样”提供。这些内容并不构成 TI 技术规范，并且不一定反映 TI 的观点；请参阅 TI 的《[使用条款](#)》。

12.3 Trademarks

TI E2E™ is a trademark of Texas Instruments.

所有商标均为其各自所有者的财产。

12.4 静电放电警告



静电放电 (ESD) 会损坏这个集成电路。德州仪器 (TI) 建议通过适当的预防措施处理所有集成电路。如果不遵守正确的处理和安装程序，可能会损坏集成电路。

ESD 的损坏小至导致微小的性能降级，大至整个器件故障。精密的集成电路可能更容易受到损坏，这是因为非常细微的参数更改都可能会导致器件与其发布的规格不相符。

12.5 术语表

[TI 术语表](#) 本术语表列出并解释了术语、首字母缩略词和定义。

13 Mechanical, Packaging, and Orderable Information

The following pages include mechanical, packaging, and orderable information. This information is the most current data available for the designated devices. This data is subject to change without notice and revision of this document. For browser-based versions of this data sheet, refer to the left-hand navigation.

PACKAGING INFORMATION

Orderable part number	Status (1)	Material type (2)	Package Pins	Package qty Carrier	RoHS (3)	Lead finish/ Ball material (4)	MSL rating/ Peak reflow (5)	Op temp (°C)	Part marking (6)
TRS3232CDBR	Obsolete	Production	SSOP (DB) 16	-	-	Call TI	Call TI	0 to 70	RS32C
TRS3232CDR	Obsolete	Production	SOIC (D) 16	-	-	Call TI	Call TI	0 to 70	TRS3232C
TRS3232CDWR	Obsolete	Production	SOIC (DW) 16	-	-	Call TI	Call TI	0 to 70	TRS3232C
TRS3232IDR	Obsolete	Production	SOIC (D) 16	-	-	Call TI	Call TI	-40 to 85	TRS3232I
TRS3232IPWR	Active	Production	TSSOP (PW) 16	2000 LARGE T&R	Yes	NIPDAU SN	Level-1-260C-UNLIM	-40 to 85	RS32I
TRS3232IPWR.A	Active	Production	TSSOP (PW) 16	2000 LARGE T&R	Yes	NIPDAU	Level-1-260C-UNLIM	-40 to 85	RS32I
TRS3232IPWRG4	Active	Production	TSSOP (PW) 16	2000 LARGE T&R	Yes	NIPDAU	Level-1-260C-UNLIM	-40 to 85	RS32I

(1) **Status:** For more details on status, see our [product life cycle](#).

(2) **Material type:** When designated, preproduction parts are prototypes/experimental devices, and are not yet approved or released for full production. Testing and final process, including without limitation quality assurance, reliability performance testing, and/or process qualification, may not yet be complete, and this item is subject to further changes or possible discontinuation. If available for ordering, purchases will be subject to an additional waiver at checkout, and are intended for early internal evaluation purposes only. These items are sold without warranties of any kind.

(3) **RoHS values:** Yes, No, RoHS Exempt. See the [TI RoHS Statement](#) for additional information and value definition.

(4) **Lead finish/Ball material:** Parts may have multiple material finish options. Finish options are separated by a vertical ruled line. Lead finish/Ball material values may wrap to two lines if the finish value exceeds the maximum column width.

(5) **MSL rating/Peak reflow:** The moisture sensitivity level ratings and peak solder (reflow) temperatures. In the event that a part has multiple moisture sensitivity ratings, only the lowest level per JEDEC standards is shown. Refer to the shipping label for the actual reflow temperature that will be used to mount the part to the printed circuit board.

(6) **Part marking:** There may be an additional marking, which relates to the logo, the lot trace code information, or the environmental category of the part.

Multiple part markings will be inside parentheses. Only one part marking contained in parentheses and separated by a "~" will appear on a part. If a line is indented then it is a continuation of the previous line and the two combined represent the entire part marking for that device.

Important Information and Disclaimer: The information provided on this page represents TI's knowledge and belief as of the date that it is provided. TI bases its knowledge and belief on information provided by third parties, and makes no representation or warranty as to the accuracy of such information. Efforts are underway to better integrate information from third parties. TI has taken and continues to take reasonable steps to provide representative and accurate information but may not have conducted destructive testing or chemical analysis on incoming materials and chemicals. TI and TI suppliers consider certain information to be proprietary, and thus CAS numbers and other limited information may not be available for release.

In no event shall TI's liability arising out of such information exceed the total purchase price of the TI part(s) at issue in this document sold by TI to Customer on an annual basis.

TAPE AND REEL INFORMATION

QUADRANT ASSIGNMENTS FOR PIN 1 ORIENTATION IN TAPE

*All dimensions are nominal

Device	Package Type	Package Drawing	Pins	SPQ	Reel Diameter (mm)	Reel Width W1 (mm)	A0 (mm)	B0 (mm)	K0 (mm)	P1 (mm)	W (mm)	Pin1 Quadrant
TRS3232IPWR	TSSOP	PW	16	2000	330.0	12.4	6.9	5.6	1.6	8.0	12.0	Q1
TRS3232IPWR	TSSOP	PW	16	2000	330.0	12.4	6.9	5.6	1.6	8.0	12.0	Q1
TRS3232IPWRG4	TSSOP	PW	16	2000	330.0	12.4	6.9	5.6	1.6	8.0	12.0	Q1

TAPE AND REEL BOX DIMENSIONS

*All dimensions are nominal

Device	Package Type	Package Drawing	Pins	SPQ	Length (mm)	Width (mm)	Height (mm)
TRS3232IPWR	TSSOP	PW	16	2000	356.0	356.0	35.0
TRS3232IPWR	TSSOP	PW	16	2000	353.0	353.0	32.0
TRS3232IPWRG4	TSSOP	PW	16	2000	356.0	356.0	35.0

D (R-PDSO-G16)

PLASTIC SMALL OUTLINE



- NOTES:
- A. All linear dimensions are in inches (millimeters).
 - B. This drawing is subject to change without notice.
 - C. Body length does not include mold flash, protrusions, or gate burrs. Mold flash, protrusions, or gate burrs shall not exceed 0.006 (0,15) each side.
 - D. Body width does not include interlead flash. Interlead flash shall not exceed 0.017 (0,43) each side.
 - E. Reference JEDEC MS-012 variation AC.

DB0016A



PACKAGE OUTLINE

SSOP - 2 mm max height

SMALL OUTLINE PACKAGE



4220763/A 05/2022

NOTES:

- All linear dimensions are in millimeters. Any dimensions in parenthesis are for reference only. Dimensioning and tolerancing per ASME Y14.5M.
- This drawing is subject to change without notice.
- This dimension does not include mold flash, protrusions, or gate burrs. Mold flash, protrusions, or gate burrs shall not exceed 0.15 mm per side.
- Reference JEDEC registration MO-150.

EXAMPLE BOARD LAYOUT

DB0016A

SSOP - 2 mm max height

SMALL OUTLINE PACKAGE



LAND PATTERN EXAMPLE
EXPOSED METAL SHOWN
SCALE: 10X



4220763/A 05/2022

NOTES: (continued)

- 5. Publication IPC-7351 may have alternate designs.
- 6. Solder mask tolerances between and around signal pads can vary based on board fabrication site.

EXAMPLE STENCIL DESIGN

DB0016A

SSOP - 2 mm max height

SMALL OUTLINE PACKAGE

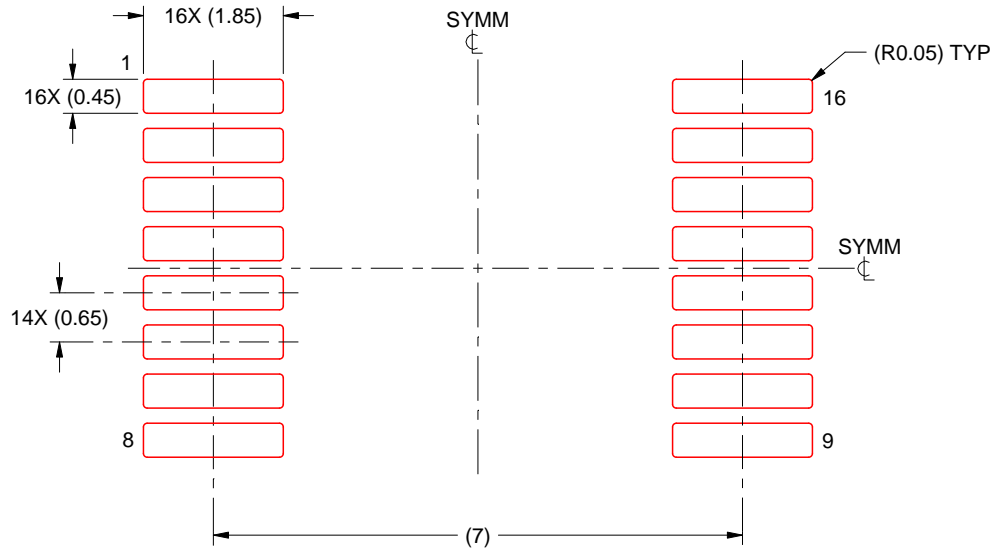

SOLDER PASTE EXAMPLE
BASED ON 0.125 mm THICK STENCIL
SCALE: 10X

4220763/A 05/2022

NOTES: (continued)

7. Laser cutting apertures with trapezoidal walls and rounded corners may offer better paste release. IPC-7525 may have alternate design recommendations.
8. Board assembly site may have different recommendations for stencil design.

GENERIC PACKAGE VIEW

DW 16

SOIC - 2.65 mm max height

7.5 x 10.3, 1.27 mm pitch

SMALL OUTLINE INTEGRATED CIRCUIT

This image is a representation of the package family, actual package may vary.
Refer to the product data sheet for package details.

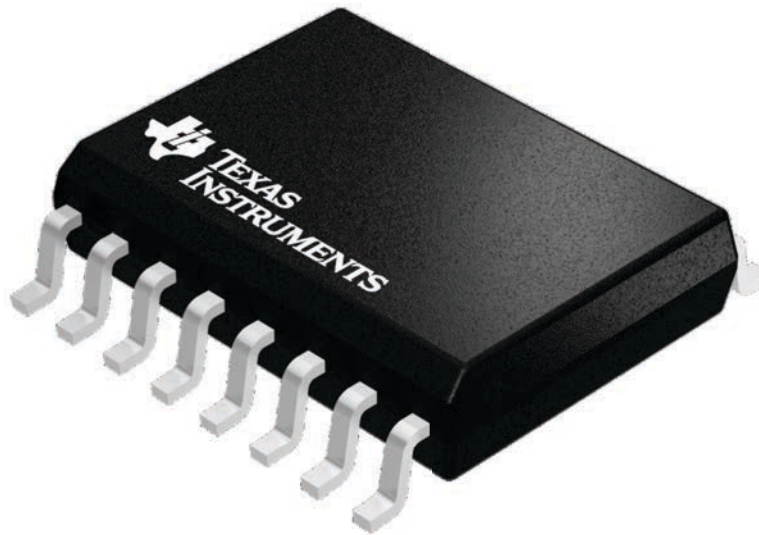

4224780/A



4220204/B 12/2023

NOTES:

1. All linear dimensions are in millimeters. Any dimensions in parenthesis are for reference only. Dimensioning and tolerancing per ASME Y14.5M.
2. This drawing is subject to change without notice.
3. This dimension does not include mold flash, protrusions, or gate burrs. Mold flash, protrusions, or gate burrs shall not exceed 0.15 mm per side.
4. This dimension does not include interlead flash. Interlead flash shall not exceed 0.25 mm per side.
5. Reference JEDEC registration MO-153.

EXAMPLE BOARD LAYOUT

PW0016A

TSSOP - 1.2 mm max height

SMALL OUTLINE PACKAGE



LAND PATTERN EXAMPLE
EXPOSED METAL SHOWN
SCALE: 10X



SOLDER MASK DETAILS

4220204/B 12/2023

NOTES: (continued)

- 6. Publication IPC-7351 may have alternate designs.
- 7. Solder mask tolerances between and around signal pads can vary based on board fabrication site.

EXAMPLE STENCIL DESIGN

PW0016A

TSSOP - 1.2 mm max height

SMALL OUTLINE PACKAGE



SOLDER PASTE EXAMPLE
BASED ON 0.125 mm THICK STENCIL
SCALE: 10X

4220204/B 12/2023

NOTES: (continued)

8. Laser cutting apertures with trapezoidal walls and rounded corners may offer better paste release. IPC-7525 may have alternate design recommendations.
9. Board assembly site may have different recommendations for stencil design.

重要通知和免责声明

TI“按原样”提供技术和可靠性数据（包括数据表）、设计资源（包括参考设计）、应用或其他设计建议、网络工具、安全信息和其他资源，不保证没有瑕疵且不做任何明示或暗示的担保，包括但不限于对适销性、与某特定用途的适用性或不侵犯任何第三方知识产权的暗示担保。

这些资源可供使用 TI 产品进行设计的熟练开发人员使用。您将自行承担以下全部责任：(1) 针对您的应用选择合适的 TI 产品，(2) 设计、验证并测试您的应用，(3) 确保您的应用满足相应标准以及任何其他安全、安保法规或其他要求。

这些资源如有变更，恕不另行通知。TI 授权您仅可将这些资源用于研发本资源所述的 TI 产品的相关应用。严禁以其他方式对这些资源进行复制或展示。您无权使用任何其他 TI 知识产权或任何第三方知识产权。对于因您对这些资源的使用而对 TI 及其代表造成的任何索赔、损害、成本、损失和债务，您将全额赔偿，TI 对此概不负责。

TI 提供的产品受 [TI 销售条款](#)、[TI 通用质量指南](#) 或 [ti.com](#) 上其他适用条款或 TI 产品随附的其他适用条款的约束。TI 提供这些资源并不会扩展或以其他方式更改 TI 针对 TI 产品发布的适用的担保或担保免责声明。除非德州仪器 (TI) 明确将某产品指定为定制产品或客户特定产品，否则其产品均为按确定价格收入目录的标准通用器件。

TI 反对并拒绝您可能提出的任何其他或不同的条款。

版权所有 © 2026，德州仪器 (TI) 公司

最后更新日期：2025 年 10 月