

具有两个 MIPI CSI-2 端口且适用于 2MP/60fps 摄像头、雷达和其他传感器的 DS90UB960-Q1 四路 FPD-Link III 解串器集线器

1 特性

- 符合 AEC-Q100 的汽车应用 标准：
 - 器件温度等级 2 级：环境工作温度范围为 -40°C 至 $+115^{\circ}\text{C}$
 - 器件 HBM ESD 分类等级 $\pm 4\text{kV}$
 - 器件 CDM ESD 分类等级 C5
- 四路解串器集线器同时从最多 4 个传感器聚合数据
- 支持 200 万像素传感器，可在 60Hz 帧速率下支持全高清 1080p 分辨率
- 多摄像头同步
- 符合 MIPI DPHY 版本 1.2/CSI-2 版本 1.3 标准
 - 2 个 CSI-2 输出端口
 - 每个 CSI-2 端口支持 1、2、3、4 个数据通道
 - CSI-2 数据速率可扩展：每个数据通道支持 400Mbps/800Mbps/1.2Gbps/1.5Gbps/1.6Gbps
 - 端口复制模式
- 超低数据和控制路径延迟
- 支持单端同轴或屏蔽双绞线 (STP) 电缆
- 自适应接收均衡
- 具有快速模式增强版 (高达 1Mbps) 的 I2C
- 用于传感器同步和诊断的灵活 GPIO
- 可与 DS90UB953-Q1、DS90UB913A-Q1、DS90UB933-Q1 串行器兼容
- 内部可编程帧同步发生器
- 线路故障检测和高级诊断

2 应用

- 汽车 ADAS
 - 后视摄像头 (RVC)
 - 环视系统 (SVS)
 - 摄像头监控系统 (CMS)
 - 前视摄像头 (FC)
 - 驾驶员监控系统 (DMS)
 - 卫星雷达、飞行时间 (ToF) 和激光雷达传感器模块
 - 传感器融合
- 安全和监控

3 说明

DS90UB960-Q1 是一款多功能摄像头集线器，可通过 FPD-Link III 接口收集从 4 个独立视频数据流接收到的串行摄像头数据。与 DS90UB953-Q1 串行器配对时，DS90UB960-Q1 可接收来自成像器的数据，可在 60Hz 帧速率下支持全高清 1080p/2MP 分辨率。接收的数据将聚合至符合 MIPI CSI-2 标准并与下游处理器互连的输出端。该器件还配有第二个 MIPI CSI-2 输出端口，可提供额外带宽或提供第二个复制输出以便进行数据记录和并行处理。

DS90UB960-Q1 包括 4 个 FPD-Link III 解串器，每个均支持通过具有成本效益的 50Ω 单端同轴或 100Ω 差分 STP 电缆进行连接。接收均衡器会自动适应以补偿电缆损耗特性，包括随时间推移而出现的劣化。

每个 FPD-Link III 接口还包括一个单独的低延迟双向控制通道，该通道可连续传送 I2C、GPIO 和其他控制信息。通用 I/O 信号（如摄像头同步和诊断 特性 所需的信号）也会利用此双向控制通道。

DS90UB960-Q1 符合 AEC-Q100 的汽车应用 要求，并采用具有成本效益且节省空间的 VQFN-64 封装。

器件信息⁽¹⁾

器件型号	封装	封装尺寸 (标称值)
DS90UB960-Q1	VQFN (64)	9.00mm x 9.00mm

(1) 如需了解所有可用封装，请参阅产品说明书末尾的可订购产品附录。

典型应用原理图

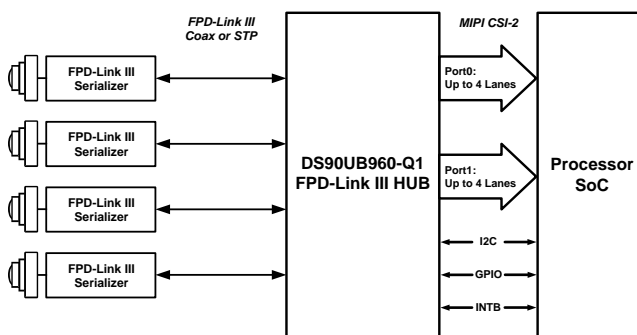

目录

1	特性	1	5.2	接收文档更新通知	3
2	应用	1	5.3	社区资源	3
3	说明	1	5.4	商标	3
4	修订历史记录	2	5.5	静电放电警告	3
5	器件和文档支持	3	5.6	Glossary	3
	5.1 文档支持	3	6	机械、封装和可订购信息	3
			6.1	Package Option Addendum	4

4 修订历史记录

注：之前版本的页码可能与当前版本有所不同。

Changes from Original (September 2016) to Revision A	Page
• 已更改 将“产品预览”更改为“生产数据”	1

5 器件和文档支持

5.1 文档支持

5.1.1 相关文档

请参阅如下相关文档：

- 《在 [DS90UB913A](#) 设计中进行同轴电缆供电》
- 《通过具有双向控制通道的 [DS90UB913/4 FPD-Link III](#) 进行 I2C 通信》
- 《通过具有双向控制通道的 [FPD-Link III](#) 进行 I2C 通信》
- 《[I2C](#) 总线上拉电阻器计算》

5.2 接收文档更新通知

要接收文档更新通知，请导航至德州仪器 TI.com.cn 上的器件产品文件夹。单击右上角的通知我进行注册，即可每周接收产品信息更改摘要。有关更改的详细信息，请查看任意已修订文档中包含的修订历史记录。

5.3 社区资源

下列链接提供到 TI 社区资源的连接。链接的内容由各个分销商“按照原样”提供。这些内容并不构成 TI 技术规范，并且不一定反映 TI 的观点；请参阅 TI 的《使用条款》。

TI E2E™ 在线社区 [TI 的工程师对工程师 \(E2E\) 社区](#)。此社区的创建目的在于促进工程师之间的协作。在 e2e.ti.com 中，您可以咨询问题、分享知识、拓展思路并与同行工程师一道帮助解决问题。

设计支持 [TI 参考设计支持](#) 可帮助您快速查找有帮助的 E2E 论坛、设计支持工具以及技术支持的联系信息。

5.4 商标

E2E is a trademark of Texas Instruments.

5.5 静电放电警告



ESD 可能会损坏该集成电路。德州仪器 (TI) 建议通过适当的预防措施处理所有集成电路。如果不遵守正确的处理措施和安装程序，可能会损坏集成电路。

ESD 的损坏小至导致微小的性能降级，大至整个器件故障。精密的集成电路可能更容易受到损坏，这是因为非常细微的参数更改都可能会导致器件与其发布的规格不相符。

5.6 Glossary

[SLYZ022](#) — *TI Glossary*.

This glossary lists and explains terms, acronyms, and definitions.

6 机械、封装和可订购信息

以下页面包括机械、封装和可订购信息。这些信息是指定器件的最新可用数据。这些数据发生变化时，我们可能不会另行通知或修订此文档。如欲获取此产品说明书的浏览器版本，请参阅左侧的导航栏。

DS90UB960-Q1

ZHCSBM2A – SEPTEMBER 2016 – REVISED JUNE 2017

www.ti.com.cn
6.1 Package Option Addendum
6.1.1 Packaging Information

Orderable Device	Status	Package Type	Package Drawing	Pins	Package Qty	Eco Plan	Lead/Ball Finish	MSL Peak Temp	Op Temp (°C)	Device Marking
DS90UB960WRTDRQ1	PREVIEW	VQFN	RTD	64	2500	TBD	Call TI	Call TI	-40 to 115	
DS90UB960WRTDTQ1	PREVIEW	VQFN	RTD	64	250	TBD	Call TI	Call TI	-40 to 115	

6.1.2 Tape and Reel Information

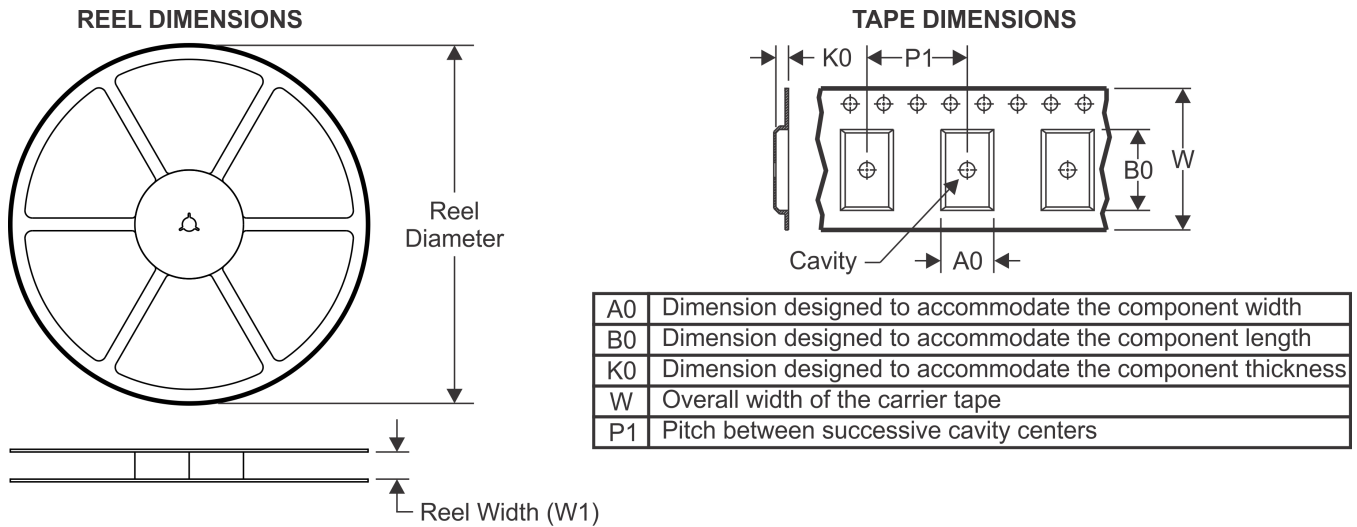

QUADRANT ASSIGNMENTS FOR PIN 1 ORIENTATION IN TAPE

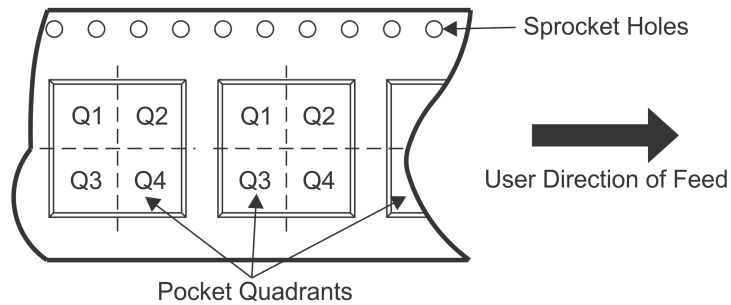

Device	Package Type	Package Drawing	Pins	SPQ	Reel Diameter (mm)	Reel Width W1 (mm)	A0 (mm)	B0 (mm)	K0 (mm)	P1 (mm)	W (mm)	Pin1 Quadrant

DS90UB960-Q1

ZHCSBM2A – SEPTEMBER 2016 – REVISED JUNE 2017

www.ti.com.cn

TAPE AND REEL BOX DIMENSIONS

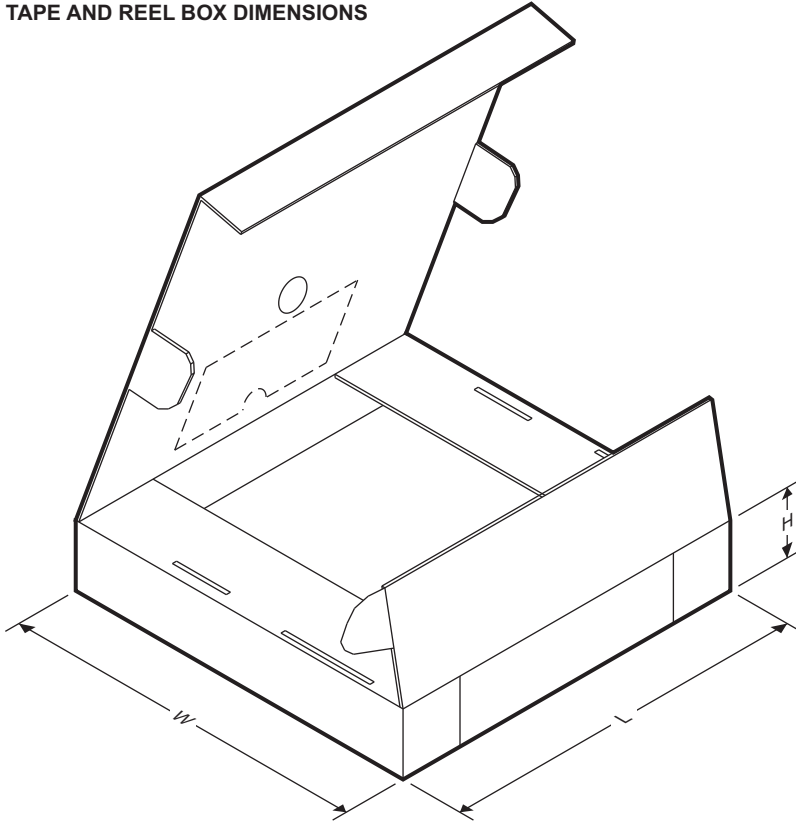

Device	Package Type	Package Drawing	Pins	SPQ	Length (mm)	Width (mm)	Height (mm)

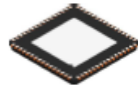

RTD0064F

PACKAGE OUTLINE

VQFN - 0.9 mm max height

PLASTIC QUAD FLATPACK - NO LEAD

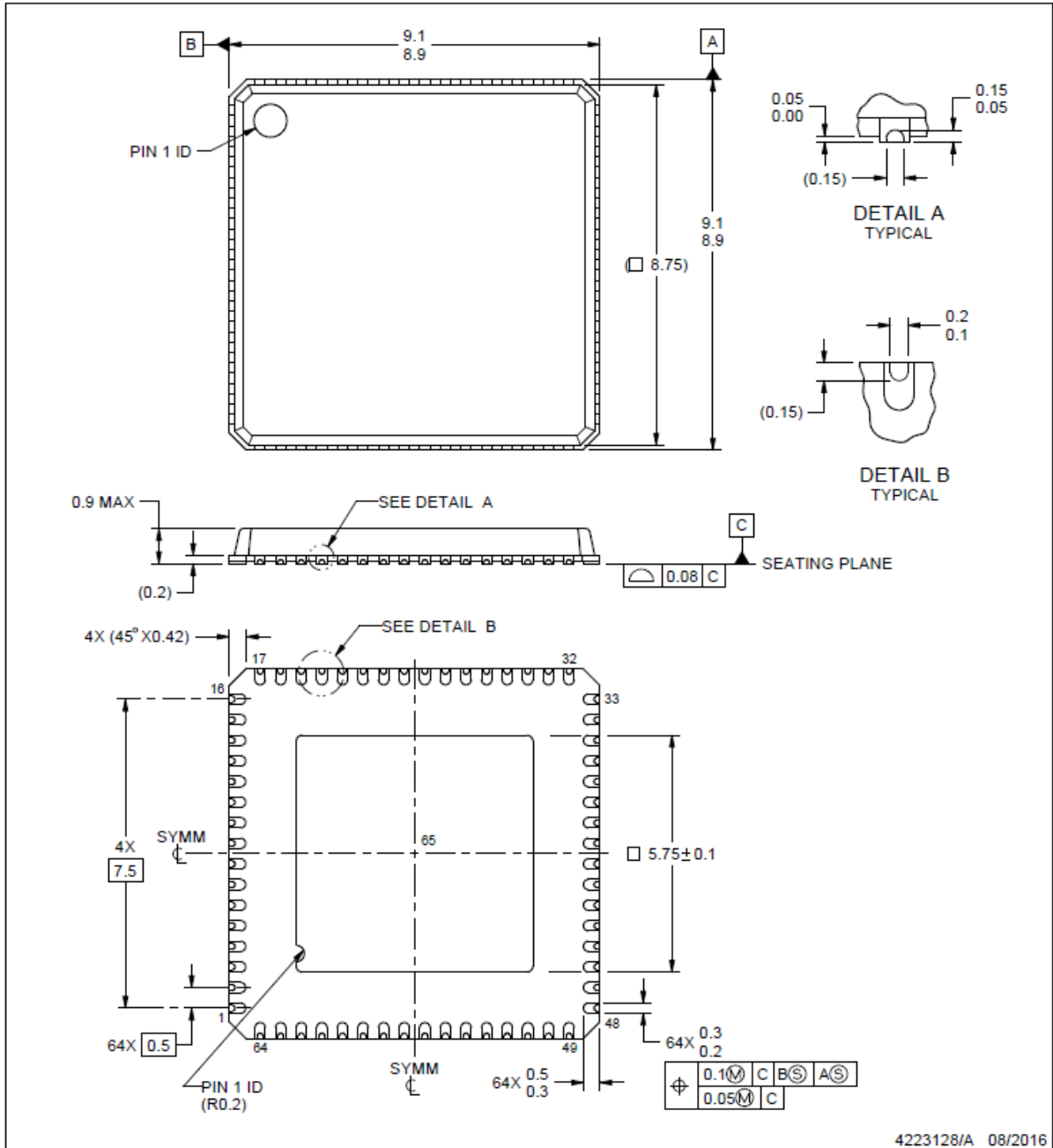

NOTES:

1. All linear dimensions are in millimeters. Any dimensions in parenthesis are for reference only. Dimensioning and tolerancing per ASME Y14.5M.
2. This drawing is subject to change without notice.
3. The package thermal pad must be soldered to the printed circuit board for thermal and mechanical performance.

EXAMPLE BOARD LAYOUT

RTD0064F

VQFN - 0.9 mm max height

PLASTIC QUAD FLATPACK - NO LEAD

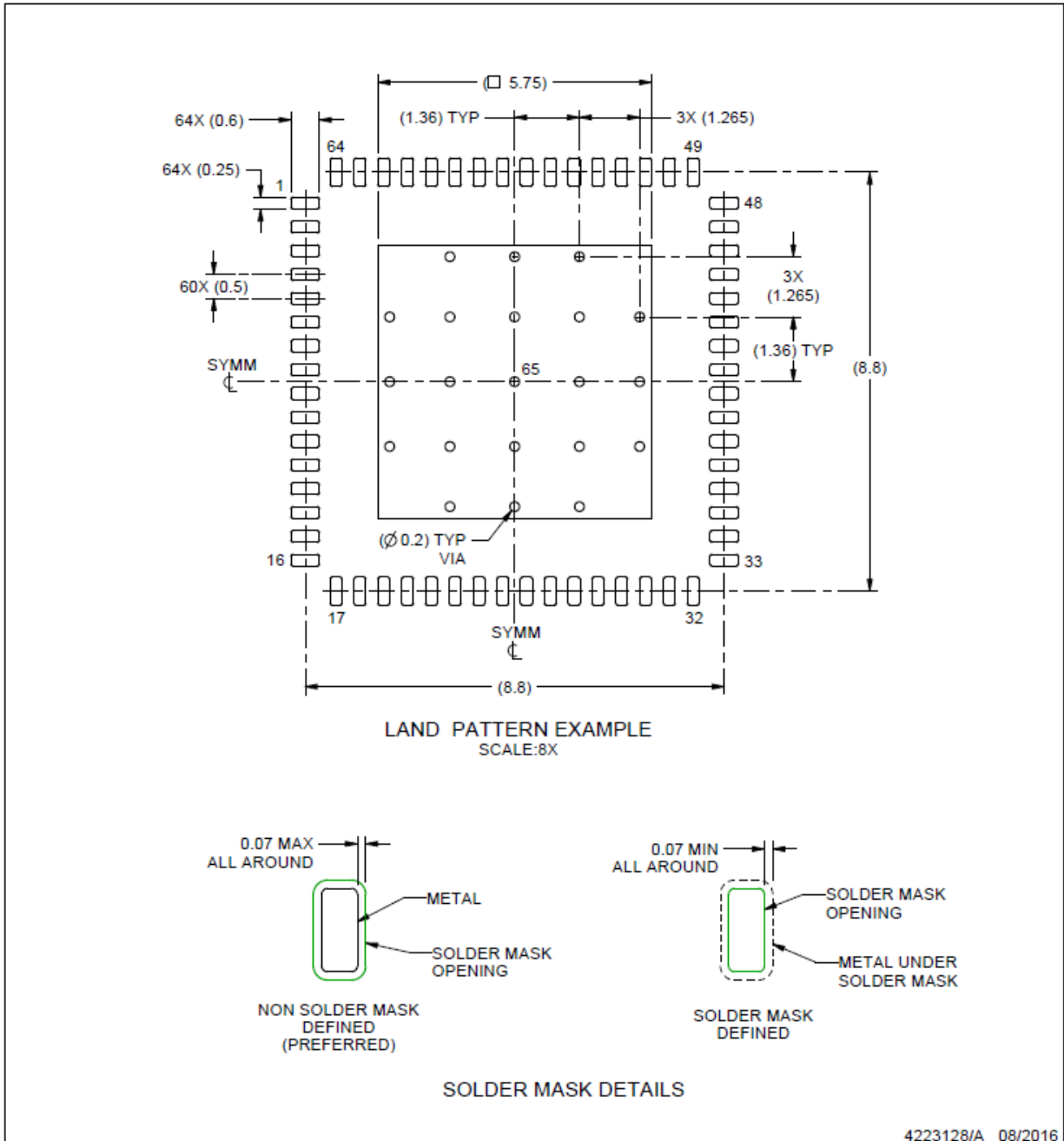

NOTES: (continued)

4. This package is designed to be soldered to a thermal pad on the board. For more information, see Texas Instruments literature number SLUA271 (www.ti.com/lit/slua271).
5. Vias are optional depending on application, refer to device data sheet. If any vias are implemented, refer to their locations shown on this view. It is recommended that vias under paste be filled, plugged or tented.

EXAMPLE STENCIL DESIGN

RTD0064F

VQFN - 0.9 mm max height

PLASTIC QUAD FLATPACK - NO LEAD

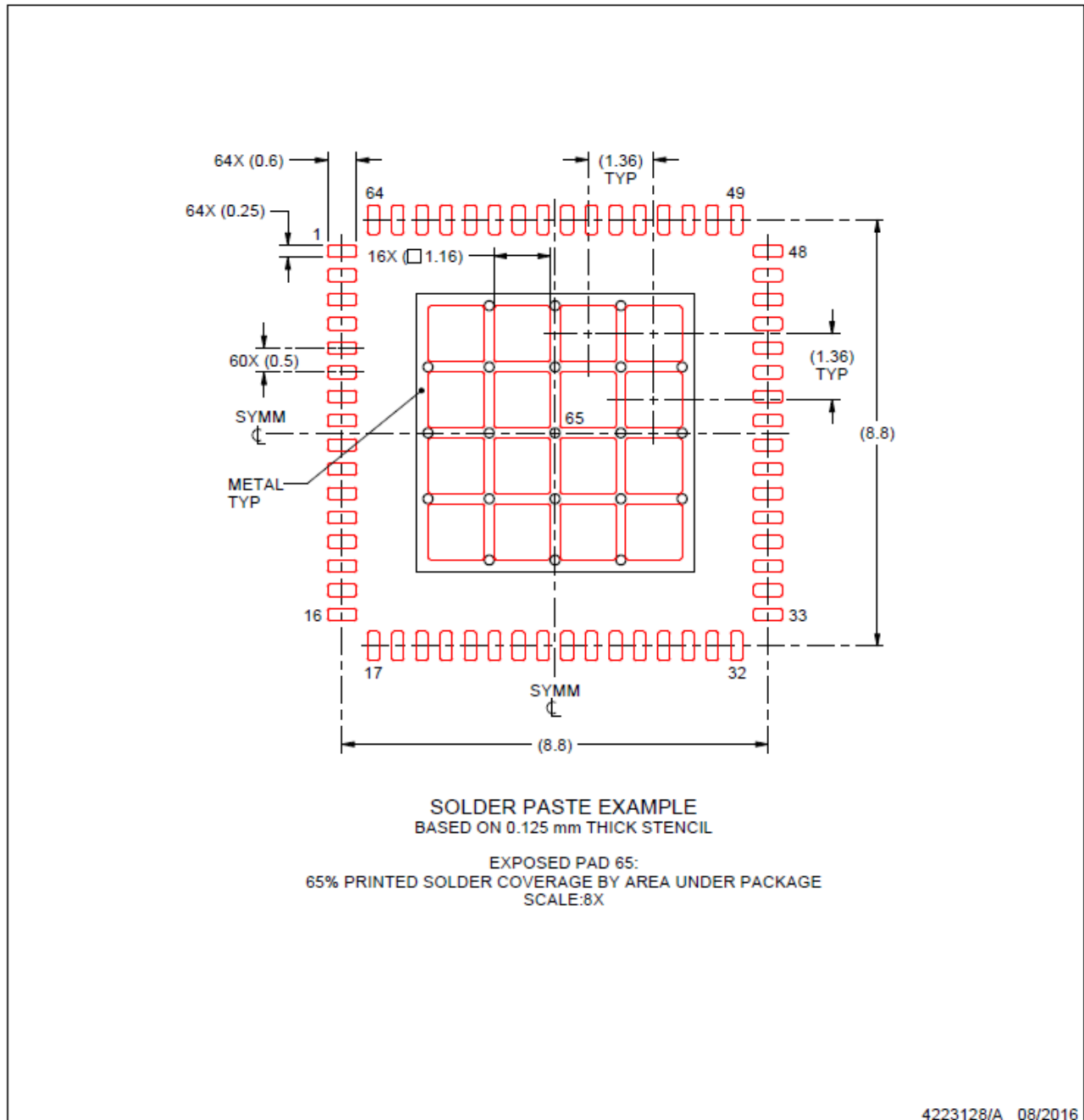

NOTES: (continued)

6. Laser cutting apertures with trapezoidal walls and rounded corners may offer better paste release. IPC-7525 may have alternate design recommendations.

PACKAGING INFORMATION

Orderable part number	Status (1)	Material type (2)	Package Pins	Package qty Carrier	RoHS (3)	Lead finish/ Ball material (4)	MSL rating/ Peak reflow (5)	Op temp (°C)	Part marking (6)
TPS65233RTER	Active	Production	WQFN (RTE) 16	3000 LARGE T&R	Yes	NIPDAU	Level-1-260C-UNLIM	-40 to 85	65233
TPS65233RTER.A	Active	Production	WQFN (RTE) 16	3000 LARGE T&R	Yes	NIPDAU	Level-1-260C-UNLIM	-40 to 85	65233
TPS65233RTERG4	Active	Production	WQFN (RTE) 16	3000 LARGE T&R	Yes	NIPDAU	Level-1-260C-UNLIM	-40 to 85	65233
TPS65233RTERG4.A	Active	Production	WQFN (RTE) 16	3000 LARGE T&R	Yes	NIPDAU	Level-1-260C-UNLIM	-40 to 85	65233
TPS65233RTET	Active	Production	WQFN (RTE) 16	250 SMALL T&R	Yes	NIPDAU	Level-1-260C-UNLIM	-40 to 85	65233
TPS65233RTET.A	Active	Production	WQFN (RTE) 16	250 SMALL T&R	Yes	NIPDAU	Level-1-260C-UNLIM	-40 to 85	65233

(1) **Status:** For more details on status, see our [product life cycle](#).

(2) **Material type:** When designated, preproduction parts are prototypes/experimental devices, and are not yet approved or released for full production. Testing and final process, including without limitation quality assurance, reliability performance testing, and/or process qualification, may not yet be complete, and this item is subject to further changes or possible discontinuation. If available for ordering, purchases will be subject to an additional waiver at checkout, and are intended for early internal evaluation purposes only. These items are sold without warranties of any kind.

(3) **RoHS values:** Yes, No, RoHS Exempt. See the [TI RoHS Statement](#) for additional information and value definition.

(4) **Lead finish/Ball material:** Parts may have multiple material finish options. Finish options are separated by a vertical ruled line. Lead finish/Ball material values may wrap to two lines if the finish value exceeds the maximum column width.

(5) **MSL rating/Peak reflow:** The moisture sensitivity level ratings and peak solder (reflow) temperatures. In the event that a part has multiple moisture sensitivity ratings, only the lowest level per JEDEC standards is shown. Refer to the shipping label for the actual reflow temperature that will be used to mount the part to the printed circuit board.

(6) **Part marking:** There may be an additional marking, which relates to the logo, the lot trace code information, or the environmental category of the part.

Multiple part markings will be inside parentheses. Only one part marking contained in parentheses and separated by a "~" will appear on a part. If a line is indented then it is a continuation of the previous line and the two combined represent the entire part marking for that device.

Important Information and Disclaimer: The information provided on this page represents TI's knowledge and belief as of the date that it is provided. TI bases its knowledge and belief on information provided by third parties, and makes no representation or warranty as to the accuracy of such information. Efforts are underway to better integrate information from third parties. TI has taken and continues to take reasonable steps to provide representative and accurate information but may not have conducted destructive testing or chemical analysis on incoming materials and chemicals. TI and TI suppliers consider certain information to be proprietary, and thus CAS numbers and other limited information may not be available for release.

In no event shall TI's liability arising out of such information exceed the total purchase price of the TI part(s) at issue in this document sold by TI to Customer on an annual basis.

TAPE AND REEL INFORMATION

QUADRANT ASSIGNMENTS FOR PIN 1 ORIENTATION IN TAPE

*All dimensions are nominal

Device	Package Type	Package Drawing	Pins	SPQ	Reel Diameter (mm)	Reel Width W1 (mm)	A0 (mm)	B0 (mm)	K0 (mm)	P1 (mm)	W (mm)	Pin1 Quadrant
TPS65233RTER	WQFN	RTE	16	3000	330.0	12.4	3.3	3.3	1.1	8.0	12.0	Q2
TPS65233RTER	WQFN	RTE	16	3000	330.0	12.4	3.3	3.3	1.1	8.0	12.0	Q2
TPS65233RTERG4	WQFN	RTE	16	3000	330.0	12.4	3.3	3.3	1.1	8.0	12.0	Q2
TPS65233RTET	WQFN	RTE	16	250	180.0	12.4	3.3	3.3	1.1	8.0	12.0	Q2
TPS65233RTET	WQFN	RTE	16	250	180.0	12.4	3.3	3.3	1.1	8.0	12.0	Q2

TAPE AND REEL BOX DIMENSIONS

*All dimensions are nominal

Device	Package Type	Package Drawing	Pins	SPQ	Length (mm)	Width (mm)	Height (mm)
TPS65233RTER	WQFN	RTE	16	3000	367.0	367.0	35.0
TPS65233RTER	WQFN	RTE	16	3000	335.0	335.0	25.0
TPS65233RTERG4	WQFN	RTE	16	3000	335.0	335.0	25.0
TPS65233RTET	WQFN	RTE	16	250	210.0	185.0	35.0
TPS65233RTET	WQFN	RTE	16	250	182.0	182.0	20.0

GENERIC PACKAGE VIEW

RTE 16

WQFN - 0.8 mm max height

3 x 3, 0.5 mm pitch

PLASTIC QUAD FLATPACK - NO LEAD

This image is a representation of the package family, actual package may vary.
Refer to the product data sheet for package details.

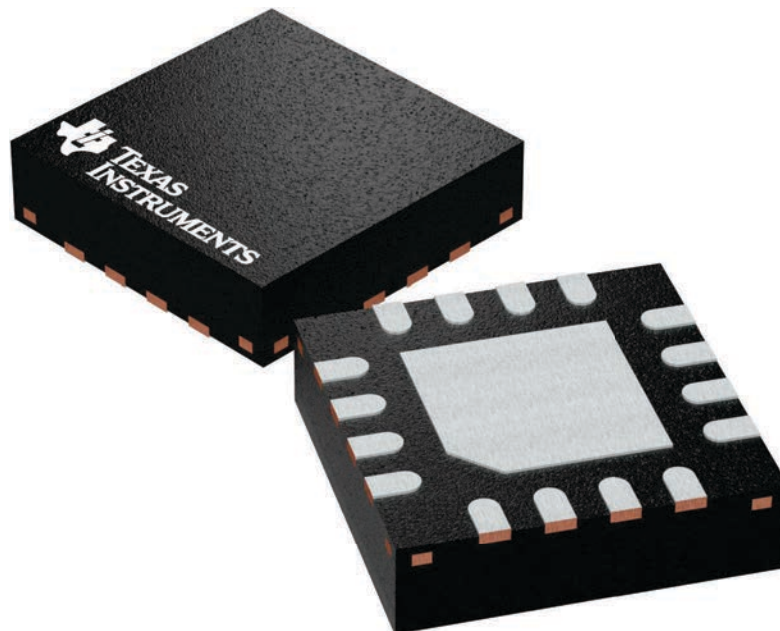

4225944/A

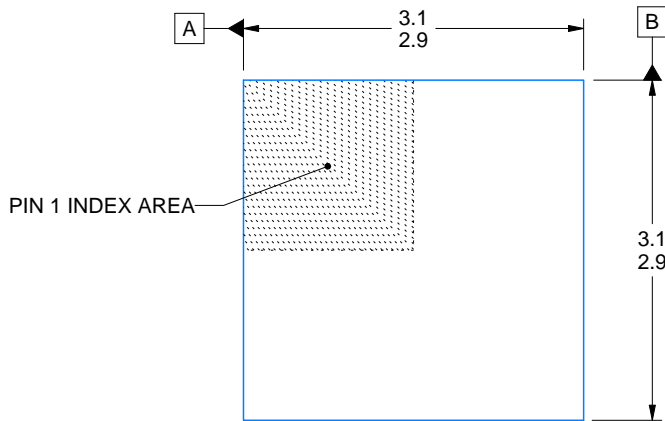

SIDE WALL METAL THICKNESS DIM A	
OPTION 1	OPTION 2
0.1	0.2

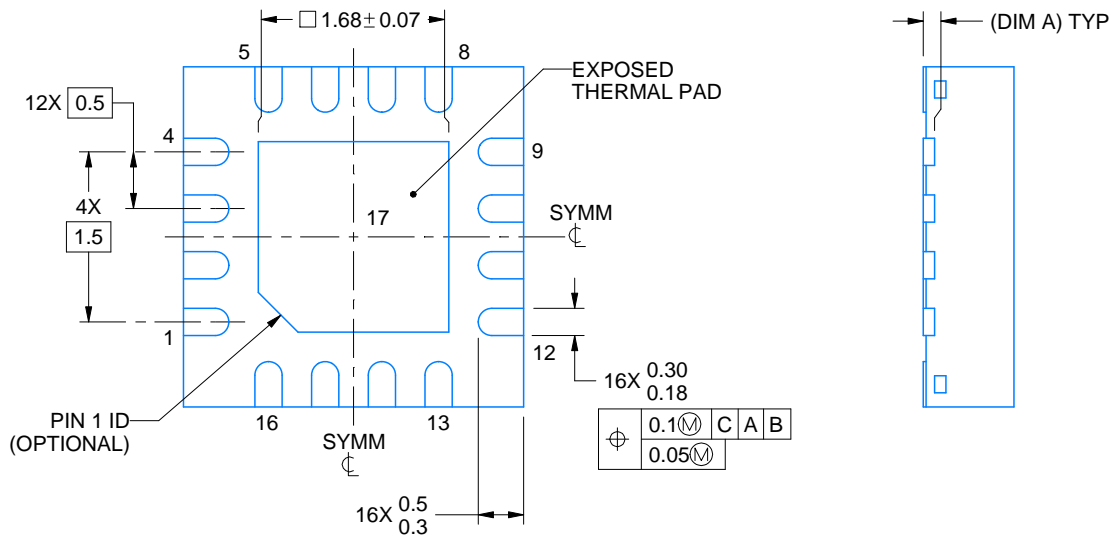
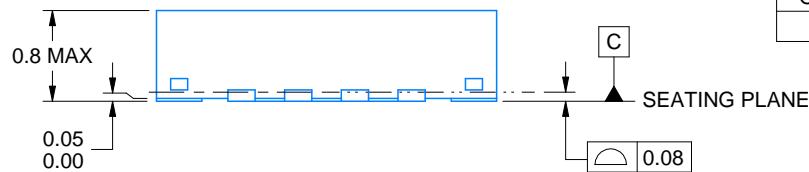

4219117/B 04/2022

NOTES:

1. All linear dimensions are in millimeters. Any dimensions in parenthesis are for reference only. Dimensioning and tolerancing per ASME Y14.5M.
2. This drawing is subject to change without notice.
3. The package thermal pad must be soldered to the printed circuit board for thermal and mechanical performance.

EXAMPLE BOARD LAYOUT

RTE0016C

WQFN - 0.8 mm max height

PLASTIC QUAD FLATPACK - NO LEAD

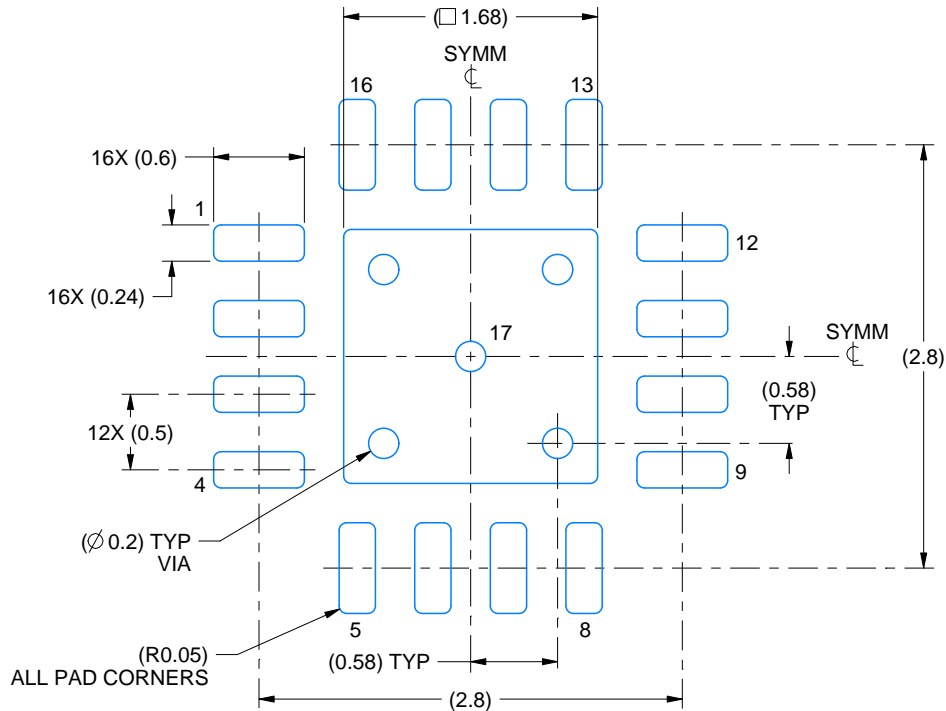

LAND PATTERN EXAMPLE
EXPOSED METAL SHOWN
SCALE:20X

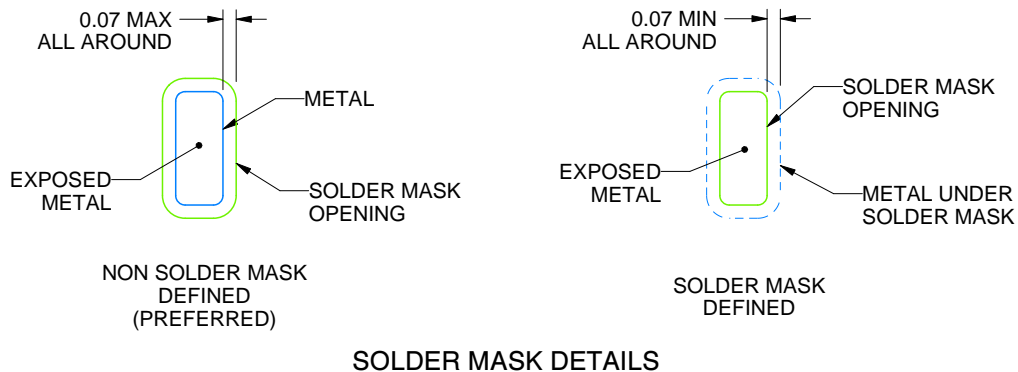

4219117/B 04/2022

NOTES: (continued)

- This package is designed to be soldered to a thermal pad on the board. For more information, see Texas Instruments literature number SLUA271 (www.ti.com/lit/sluea271).
- Vias are optional depending on application, refer to device data sheet. If any vias are implemented, refer to their locations shown on this view. It is recommended that vias under paste be filled, plugged or tented.

EXAMPLE STENCIL DESIGN

RTE0016C

WQFN - 0.8 mm max height

PLASTIC QUAD FLATPACK - NO LEAD

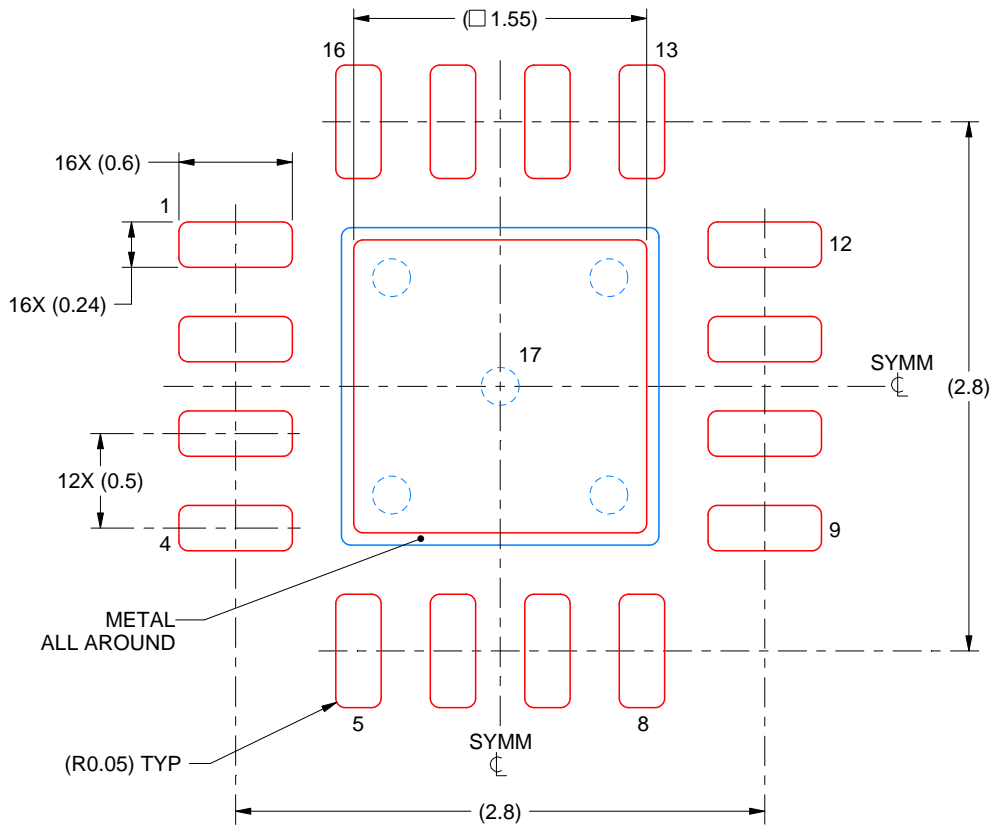

SOLDER PASTE EXAMPLE
BASED ON 0.125 mm THICK STENCIL

EXPOSED PAD 17:
85% PRINTED SOLDER COVERAGE BY AREA UNDER PACKAGE
SCALE:25X

4219117/B 04/2022

NOTES: (continued)

6. Laser cutting apertures with trapezoidal walls and rounded corners may offer better paste release. IPC-7525 may have alternate design recommendations.

重要通知和免责声明

TI“按原样”提供技术和可靠性数据（包括数据表）、设计资源（包括参考设计）、应用或其他设计建议、网络工具、安全信息和其他资源，不保证没有瑕疵且不做任何明示或暗示的担保，包括但不限于对适销性、与某特定用途的适用性或不侵犯任何第三方知识产权的暗示担保。

这些资源可供使用 TI 产品进行设计的熟练开发人员使用。您将自行承担以下全部责任：(1) 针对您的应用选择合适的 TI 产品，(2) 设计、验证并测试您的应用，(3) 确保您的应用满足相应标准以及任何其他安全、安保法规或其他要求。

这些资源如有变更，恕不另行通知。TI 授权您仅可将这些资源用于研发本资源所述的 TI 产品的相关应用。严禁以其他方式对这些资源进行复制或展示。您无权使用任何其他 TI 知识产权或任何第三方知识产权。对于因您对这些资源的使用而对 TI 及其代表造成的任何索赔、损害、成本、损失和债务，您将全额赔偿，TI 对此概不负责。

TI 提供的产品受 [TI 销售条款](#)、[TI 通用质量指南](#) 或 [ti.com](#) 上其他适用条款或 TI 产品随附的其他适用条款的约束。TI 提供这些资源并不会扩展或以其他方式更改 TI 针对 TI 产品发布的适用的担保或担保免责声明。除非德州仪器 (TI) 明确将某产品指定为定制产品或客户特定产品，否则其产品均为按确定价格收入目录的标准通用器件。

TI 反对并拒绝您可能提出的任何其他或不同的条款。

版权所有 © 2025，德州仪器 (TI) 公司

最后更新日期：2025 年 10 月