

## TPS624xx-Q1 汽车 2.25 MHz 固定输出电压双路降压转换器

### 1 特性

- 符合汽车应用要求
- 具有符合 AEC-Q100 标准的下列特性：
  - 器件温度等级 1：-40°C 至 125°C 的工作结温范围
  - 器件 HBM ESD 分类等级 2
  - 器件 CDM ESD 分类等级 C4B
- 高效率 - 高达 95%
- $V_{IN}$  范围为 2.5 V 至 6 V
- 2.25 MHz 固定频率运行
- 输出电流 TPS62406-Q1 1000mA/400mA
- 输出电流 TPS62407-Q1 400mA/600mA
- 输出电流 TPS62422-Q1 1000mA/600mA
- 输出电流 TPS62423-Q1 800mA/800mA
- 输出电流 TPS62424-Q1 800mA/800mA
- 固定输出电压
- EasyScale™ 可选单引脚串行接口
- 轻负载电流状态下进入节能模式
- 180° 异相运行
- PWM 模式下的输出电压精度  $\pm 1\%$
- 适用于两个转换器的典型 32  $\mu A$  静态电流
- 可实现最低压降的 100% 占空比

### 2 应用

- 汽车负载点稳压器
- ADAS 摄像头模块
- 后视镜更换 (CMS)
- 信息娱乐系统与仪表组

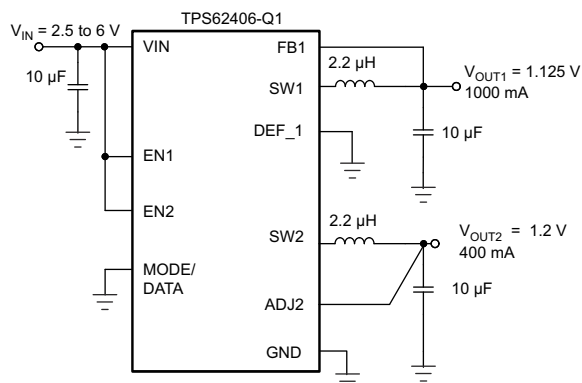

简化版原理图

### 3 说明

TPS624xx-Q1 器件系列是适用于汽车应用 (例如高级驾驶辅助系统 (ADAS)) 的双路同步降压直流/直流转换器。该系列可提供两组由标准 3.3 V 或 5 V 电压轨供电的独立输出电压轨, 以及经过优化的固定输出电压, 为 ADAS 摄像头模块中的 CMOS 成像仪或串行器-解串器供电。

EasyScale™ 串行接口支持在运行过程中对输出电压进行修改。固定输出电压版本 TPS624xx-Q1 支持对低功耗处理器进行单引脚控制的简单动态电压调节。

TPS624xx-Q1 器件系列可在 2.25 MHz 固定开关频率下运行, 在轻负载电流情况下会进入省电模式, 以便在整个负载电流范围内保持高效率。对于低噪声应用, 可通过拉高 MODE/DATA 引脚来强制器件进入固定频率 PWM 模式。关断模式可以将电流消耗降低至 1.2  $\mu A$  的典型值。此器件允许使用小型电感器和电容器, 可实现一个小型解决方案尺寸。

器件信息<sup>(1)</sup>

器件型号	封装	封装尺寸 (标称值)
TPS62406-Q1	VSON (10)	3.00mm × 3.00mm
TPS62407-Q1		
TPS62422-Q1		
TPS62423-Q1		
TPS62424-Q1		

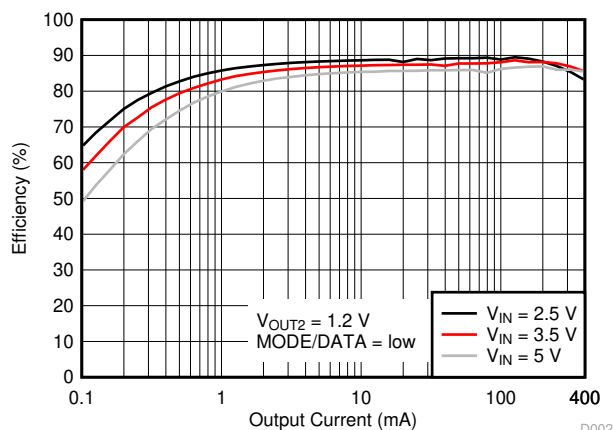

TPS62406-Q1 效率与输出电流间的关系,  $V_{OUT2}$

D002



## Table of Contents

<b>1 特性</b> .....	1	8.4 Device Functional Modes.....	13
<b>2 应用</b> .....	1	8.5 Programming.....	15
<b>3 说明</b> .....	1	<b>9 Application and Implementation</b> .....	21
<b>4 Revision History</b> .....	2	9.1 Application Information.....	21
<b>5 Device Comparison Table</b> .....	3	9.2 Typical Application.....	21
<b>6 Pin Configuration and Functions</b> .....	3	9.3 System Examples.....	27
<b>7 Specifications</b> .....	5	<b>10 Power Supply Recommendations</b> .....	29
7.1 Absolute Maximum Ratings.....	5	<b>11 Layout</b> .....	30
7.2 ESD Ratings.....	5	11.1 Layout Guidelines.....	30
7.3 Recommended Operating Conditions.....	5	11.2 Layout Example.....	30
7.4 Thermal Information.....	5	<b>12 Device and Documentation Support</b> .....	31
7.5 Electrical Characteristics.....	5	12.1 支持资源.....	31
7.6 Timing Requirements.....	8	12.2 接收文档更新通知.....	31
7.7 Switching Characteristics.....	8	12.3 Trademarks.....	31
7.8 Typical Characteristics.....	9	12.4 Electrostatic Discharge Caution.....	31
<b>8 Detailed Description</b> .....	10	12.5 术语表.....	31
8.1 Overview.....	10	<b>13 Mechanical, Packaging, and Orderable Information</b> .....	32
8.2 Functional Block Diagram.....	11		
8.3 Feature Description.....	12		

## 4 Revision History

注：以前版本的页码可能与当前版本的页码不同

<b>Changes from Revision D (August 2018) to Revision E (March 2022)</b>	<b>Page</b>
• 更新了整个文档中的表格、图和交叉参考的编号格式.....	1
• Removed manual package option addendum, tape and reel information, and package drawings.....	32

---

<b>Changes from Revision * (December 2014) to Revision A (October 2015)</b>	<b>Page</b>
• Changed the I <sub>OUT1</sub> and I <sub>OUT2</sub> current for the TPS62406-Q1 device in the <i>Device Comparison Table</i> .....	3
• Changed forward current limit PMOS and NMOS for the TPS62406-Q1.....	5

## 5 Device Comparison Table

PART NUMBER	DEFAULT OUTPUT VOLTAGE			OUTPUT CURRENT	
	V <sub>OUT1</sub>	Fixed default	DEF_1 = High 1.125 V DEF_1 = Low 1.125 V	I <sub>OUT1</sub>	1000 mA
TPS62406-Q1	V <sub>OUT2</sub>	Fixed default 1.2 V		I <sub>OUT2</sub>	400 mA
	V <sub>OUT1</sub>	Fixed default	DEF_1 = High 1.225 V DEF_1 = Low 1.225 V	I <sub>OUT1</sub>	400 mA
TPS62407-Q1	V <sub>OUT2</sub>	Fixed default 1.85 V		I <sub>OUT2</sub>	600 mA
	V <sub>OUT1</sub>	Fixed default	DEF_1 = High 1.8 V DEF_1 = Low 1.15 V	I <sub>OUT1</sub>	1000 mA
TPS62422-Q1	V <sub>OUT2</sub>	Fixed default 1.2V		I <sub>OUT2</sub>	600 mA
	V <sub>OUT1</sub>	Fixed default	DEF_1 = High 1.5 V DEF_1 = Low 1.2 V	I <sub>OUT1</sub>	800 mA
TPS62423-Q1	V <sub>OUT2</sub>	Fixed default 1.8V		I <sub>OUT2</sub>	800 mA
	V <sub>OUT1</sub>	Fixed default	DEF_1 = High 1.3 V DEF_1 = Low 1.1 V	I <sub>OUT1</sub>	800 mA
TPS62424-Q1	V <sub>OUT2</sub>	Fixed default 1.8V		I <sub>OUT2</sub>	800 mA

## 6 Pin Configuration and Functions



图 6-1. DRC Package 10-Pin VSON With Thermal Pad Top View

表 6-1. Pin Functions

PIN		I/O	DESCRIPTION
NAME	NO.		
ADJ2	1	I	Output voltage sense pin for the internal feedback divider. This pin must connect directly to the output. If using the EasyScale interface-on converter 2, this pin must also connect directly to the output.
DEF_1	5	I	This pin defines the output voltage of converter 1 and is a digital input, that selects between two fixed default output voltages. See #5 for output voltage setting of the different device options. For TPS62406-Q1 and TPS62407-Q1 the output voltage is same independent of DEF_1 pin level. This pin must be terminated.
EN1	7	I	Enable input for converter 1, active-high. This pin must be terminated.
EN2	9	I	Enable input for converter 2, active-high. This pin must be terminated.
FB1	4	I	Output voltage sense pin for the internal feedback divider. This pin is connected to the output.
GND	8	—	GND for both converters; connect this pin to the thermal pad.

表 6-1. Pin Functions (continued)

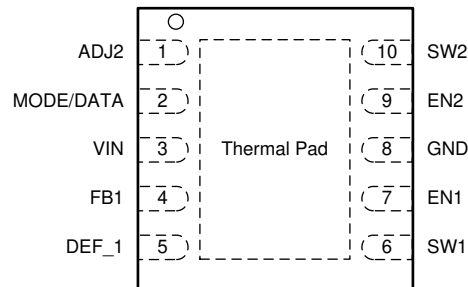
PIN		I/O	DESCRIPTION
NAME	NO.		
MODE/DATA	2	I/O	<p>This pin has two functions:</p> <ol style="list-style-type: none"> <li>1. Operation-mode selection: With low level, enables power-save mode where the device operates in PFM mode at light loads and automatically enters PWM mode at heavy loads. Pulling this PIN to high forces the device to operate in PWM mode over the whole load range.</li> <li>2. EasyScale interface function: One-wire serial interface to change the output voltage of both converters. The pin has an open-drain output to provide an acknowledge condition if requested. The current into the open-drain output stage may not exceed 500 <math>\mu</math> A. The EasyScale interface is active if either EN1 or EN2 is high.</li> </ol>
SW1	6	I/O	Switch pin of converter 1. Connect to inductor
SW2	10	I/O	Switch pin of converter 2. Connect to inductor
VIN	3	I	Input pin, connect to supply or battery voltage, 2.5 V to 6 V. Connect the input capacitor $C_{IN}$ as close as possible between VIN pin and GND pin.
Thermal pad		—	Connect to GND

## 7 Specifications

### 7.1 Absolute Maximum Ratings

over operating junction temperature range (unless otherwise noted)<sup>(1)</sup>

		MIN	MAX	UNIT
Input voltage <sup>(2)</sup>	V <sub>IN</sub>	- 0.3	7	V
Voltage <sup>(2)</sup>	EN, MODE/DATA, DEF_1	- 0.3	V <sub>IN</sub> + 0.3, ≤ 7	V
	SW1, SW2	- 0.3	7	V
	ADJ2, FB1	- 0.3	V <sub>IN</sub> + 0.3, ≤ 7	V
Current	MODE/DATA		≤ 0.5	mA
Maximum operating junction temperature, T <sub>Jmax</sub>			150	°C
Storage temperature, T <sub>stg</sub>		- 65	150	°C

(1) Stresses beyond those listed under *Absolute Maximum Ratings* may cause permanent damage to the device. These are stress ratings only, and do not imply functional operation of the device at these or any other conditions beyond those indicated under *Recommended Operating Conditions*. Exposure to absolute-maximum-rated conditions for extended periods may affect device reliability.

(2) All voltage values are with respect to the network ground terminal.

### 7.2 ESD Ratings

		VALUE	UNIT
V <sub>(ESD)</sub> Electrostatic discharge	Human body model (HBM), per AEC Q100-002 <sup>(1)</sup>	±2000	V
	Charged device model (CDM), per AEC Q100-011	All pins	±500
		Corner pins (1, 5, 6, and 10)	±750

(1) AEC Q100-002 indicates HBM stressing is done in accordance with the ANSI/ESDA/JEDEC JS-001 specification.

### 7.3 Recommended Operating Conditions

over operating junction temperature range (unless otherwise noted)

		MIN	MAX	UNIT
V <sub>IN</sub>	Supply voltage	2.5	6	V
T <sub>J</sub>	Operating junction temperature	- 40	125	°C

### 7.4 Thermal Information

THERMAL METRIC <sup>(1)</sup>		TPS624xx-Q1	UNIT
		DRC (VSON)	
		10 PINS	
R <sub>θJA</sub>	Junction-to-ambient thermal resistance	42.7	°C/W
R <sub>θJC(top)</sub>	Junction-to-case (top) thermal resistance	46.9	°C/W
R <sub>θJB</sub>	Junction-to-board thermal resistance	18.1	°C/W
ψ <sub>JT</sub>	Junction-to-top characterization parameter	0.5	°C/W
ψ <sub>JB</sub>	Junction-to-board characterization parameter	18.3	°C/W
R <sub>θJC(bot)</sub>	Junction-to-case (bottom) thermal resistance	3.1	°C/W

(1) For more information about traditional and new thermal metrics, see the *Semiconductor and IC Package Thermal Metrics* application report, [SPRA953](#).

### 7.5 Electrical Characteristics

V<sub>IN</sub> = 3.6 V, EN1 = EN2 = V<sub>IN</sub>, MODE = GND, L1 = L2 = 2.2 μH, C<sub>OUT1</sub> = C<sub>OUT2</sub> = 20 μF, T<sub>J</sub> = - 40°C to 125°C, typical values are at T<sub>J</sub> = 25°C (unless otherwise noted)

PARAMETER	TEST CONDITIONS	MIN	TYP	MAX	UNIT
<b>SUPPLY CURRENT</b>					
V <sub>IN</sub>	Input voltage range	2.5		6	V

$V_{IN} = 3.6\text{ V}$ ,  $EN1 = EN2 = V_{IN}$ ,  $MODE = GND$ ,  $L1 = L2 = 2.2\ \mu\text{H}$ ,  $C_{OUT1} = C_{OUT2} = 20\ \mu\text{F}$ ,  $T_J = -40^\circ\text{C}$  to  $125^\circ\text{C}$ , typical values are at  $T_J = 25^\circ\text{C}$  (unless otherwise noted)

PARAMETER		TEST CONDITIONS	MIN	TYP	MAX	UNIT
$I_Q$	Operating quiescent current	One converter, no load on the output. PFM mode enabled (MODE/DATA = GND) device not switching, EN1 = 1 or EN2 = 1		19	35	$\mu\text{A}$
		Two converters, no load on the output. PFM mode enabled (MODE/DATA = GND) device not switching, EN1 = EN2 = 1		32	50	
		No load on the output, MODE/DATA = GND, for one converter <sup>(1)</sup>		23		
			No load on the output, MODE/DATA = $V_{IN}$ , for one converter <sup>(1)</sup>		3.6	
$I_{SD}$	Shutdown current	EN1, EN2 = GND, $V_{IN} = 3.6\text{ V}$ <sup>(2)</sup>		1.2	3	$\mu\text{A}$
		EN1, EN2 = GND, $V_{IN}$ ramped from 0 V to 3.6 V <sup>(3)</sup>		0.1	1.5	
$V_{UVLO}$	Undervoltage lockout threshold	Falling		1.5	2.35	V
		Rising			2.4	
<b>ENABLE EN1, EN2</b>						
$V_{IH}$	High-level input voltage range, EN1, EN2		1.2		$V_{IN}$	V
$V_{IL}$	Low-level input voltage range, EN1, EN2		0		0.4	V
$I_{IN}$	Input bias current, EN1, EN2	EN1, EN2 = GND or $V_{IN}$		0.05	1	$\mu\text{A}$
<b>DEF_1 INPUT</b>						
$V_{DEF\_1H}$	DEF_1 high-level digital input voltage range		0.9		$V_{IN}$	V
$V_{DEF\_1L}$	DEF_1 low-level digital input voltage range		0		0.4	V
$I_{IN}$	Input bias current DEF_1	DEF_1 = GND or $V_{IN}$		0.01	1	$\mu\text{A}$
<b>MODE/DATA</b>						
$V_{IH}$	High-level input voltage range, MODE/DATA		1.2		$V_{IN}$	V
$V_{IL}$	Low-level input voltage range, MODE/DATA		0		0.4	V
$I_{IN}$	Input bias current, MODE/DATA	MODE/DATA = GND or $V_{IN}$		0.01	1	$\mu\text{A}$
$V_{OH}$	Acknowledge output voltage high	Open drain, through external pullup resistor			$V_{IN}$	V
$V_{OL}$	Acknowledge output voltage low	Open drain, sink current 500 $\mu\text{A}$	0		0.4	V
<b>POWER SWITCH</b>						
$r_{DS(on)}$	P-channel MOSFET on-resistance, converter 1 and 2	$V_{IN} = V_{GS} = 3.6\text{ V}$		280	620	$\text{m}\Omega$
$I_{LK\_PMOS}$	P-channel leakage current	$V_{DS} = 6\text{ V}$			1	$\mu\text{A}$
$r_{DS(on)}$	N-channel MOSFET on-resistance converter 1 and 2	$V_{IN} = V_{GS} = 3.6\text{ V}$		200	450	$\text{m}\Omega$
$I_{LK\_SW1/SW2}$	Leakage current into SW1 or SW2 pin	Includes N-channel leakage current, $V_{IN} = \text{open}$ , $V_{SW} = 6\text{ V}$ , EN = GND <sup>(4)</sup>		6	7.5	$\mu\text{A}$

$V_{IN} = 3.6\text{ V}$ ,  $EN1 = EN2 = V_{IN}$ ,  $MODE = GND$ ,  $L1 = L2 = 2.2\ \mu\text{H}$ ,  $C_{OUT1} = C_{OUT2} = 20\ \mu\text{F}$ ,  $T_J = -40^\circ\text{C}$  to  $125^\circ\text{C}$ , typical values are at  $T_J = 25^\circ\text{C}$  (unless otherwise noted)

PARAMETER		TEST CONDITIONS	MIN	TYP	MAX	UNIT			
$I_{LIMF}$	Forward current limit PMOS and NMOS	TPS62406-Q1 $V_{OUT1}$	$2.5\text{ V} \leq V_{IN} \leq 6\text{ V}$			1.18	1.4	1.61	A
		TPS62406-Q1 $V_{OUT2}$	$2.5\text{ V} \leq V_{IN} \leq 6\text{ V}$			0.68	0.8	0.92	
		TPS62407-Q1 $V_{OUT1}$	$2.5\text{ V} \leq V_{IN} \leq 6\text{ V}$			0.68	0.8	0.92	
		TPS62407-Q1 $V_{OUT2}$	$2.5\text{ V} \leq V_{IN} \leq 6\text{ V}$			0.75	1	1.15	
		TPS62422-Q1 $V_{OUT1}$	$2.5\text{ V} \leq V_{IN} \leq 6\text{ V}$			1.18	1.4	1.61	
		TPS62422-Q1 $V_{OUT2}$	$2.5\text{ V} \leq V_{IN} \leq 6\text{ V}$			0.75	1	1.15	
		TPS62423-Q1 $V_{OUT1}$	$2.5\text{ V} \leq V_{IN} \leq 6\text{ V}$			1	1.2	1.38	
		TPS62423-Q1 $V_{OUT2}$	$2.5\text{ V} \leq V_{IN} \leq 6\text{ V}$			1	1.2	1.38	
		TPS62424-Q1 $V_{OUT1}$	$2.5\text{ V} \leq V_{IN} \leq 6\text{ V}$			1	1.2	1.38	
		TPS62424-Q1 $V_{OUT2}$	$2.5\text{ V} \leq V_{IN} \leq 6\text{ V}$			1	1.2	1.38	
$T_{SD}$	Thermal shutdown	Increasing junction temperature			150		$^\circ\text{C}$		
	Thermal shutdown hysteresis	Decreasing junction temperature			20		$^\circ\text{C}$		
<b>OUTPUT</b>									
$V_{ref}$	Internal Reference voltage				600		mV		
$V_{OUTx(PFM)}$	DC output voltage accuracy	Voltage positioning active, MODE/DATA = GND, device operating in PFM mode, $V_{IN} = 2.5\text{ V}$ to $5\text{ V}$ <sup>(5)</sup> <sup>(6)</sup>			- 1.5%	1%	2.5%		
$V_{OUTx(PWM)}$		MODE/DATA = GND; device operating in PWM mode, $V_{IN} = 2.5\text{ V}$ to $6\text{ V}$ <sup>(6)</sup>			- 1%	0%	1%		
		$V_{IN} = 2.5\text{ V}$ to $6\text{ V}$ , MODE/DATA = $V_{IN}$ , Fixed PWM operation, $0\text{ mA} < I_{OUT1} < 400\text{ mA}$ ; $0\text{ mA} < I_{OUT2} < 600\text{ mA}$ <sup>(7)</sup>			- 1%	0%	1%		
	DC output voltage load regulation	PWM operation mode			0.5		%/A		

- (1) Device is switching with no load on the output,  $L1 = L2 = 3.3\ \mu\text{H}$ , value includes losses of the coil.
- (2) These values are valid after enabling the device one time ( $EN1$  or  $EN2 = \text{high}$ ) and maintaining supply voltage  $V_{IN}$ .
- (3) These values are valid when the device is disabled ( $EN1$  and  $EN2$  low) and supply voltage  $V_{IN}$  is powered up. The values remain valid until enabling the device the first time ( $EN1$  or  $EN2 = \text{high}$ ). After the first enable, Note 3 becomes valid.
- (4) An internal resistor of  $1\text{ M}\Omega$  connects pins SW1 and SW2 to GND.
- (5) Configuration L1 or L2 typ.  $2.2\ \mu\text{H}$ ,  $C_{OUTx}$  typ  $20\ \mu\text{F}$ . See parameter measurement information, the output voltage ripple in PFM mode depends on the effective capacitance of the output capacitor; larger output capacitors lead to tighter output voltage tolerance.
- (6) In power-save mode, the device typically enters PWM operation at  $I_{PSM} = V_{IN} / 32\ \Omega$ .
- (7) For  $V_{OUTx} > 2\text{ V}$ ,  $V_{IN\ min} = V_{OUTx} + 0.5\text{ V}$

## 7.6 Timing Requirements

			MIN	NOM	MAX	UNIT
<b>INTERFACE TIMING</b>						
$t_{Start}$	Start time		2			$\mu s$
$t_{H\_LB}$	High-time low bit, logic 0 detection	Signal level on MODE/DATA pin is $> 1.2 V$	2		200	$\mu s$
$t_{L\_LB}$	Low-time low bit, logic 0 detection	Signal level on MODE/DATA pin $< 0.4 V$	$2 \times t_{H\_LB}$		400	$\mu s$
$t_{L\_HB}$	Low-time high bit, logic 1 detection	Signal level on MODE/DATA pin $< 0.4 V$	2		200	$\mu s$
$t_{H\_HB}$	High-time high bit, logic 1 detection	Signal level on MODE/DATA pin is $> 1.2 V$	$2 \times t_{L\_HB}$		400	$\mu s$
$t_{EOS}$	End of stream		2			$\mu s$
$t_{ACKN}$	Duration of acknowledge condition (MODE/DATA line pulled low by the device)	$V_{IN} 2.5 V$ to $6 V$	400		520	$\mu s$
$t_{valACK}$	Acknowledge valid time				2	$\mu s$
$t_{timeout}$	Time-out for entering power-save mode	MODE/DATA pin changes from high to low			520	$\mu s$

## 7.7 Switching Characteristics

$V_{IN} = 3.6 V$ ,  $EN1 = EN2 = V_{IN}$ ,  $MODE = GND$ ,  $L1 = L2 = 2.2 \mu H$ ,  $C_{OUT1} = C_{OUT2} = 20 \mu F$ ,  $T_J = -40^\circ C$  to  $125^\circ C$ , typical values are at  $T_J = 25^\circ C$  (unless otherwise noted)

PARAMETER	TEST CONDITIONS	MIN	TYP	MAX	UNIT	
<b>OSCILLATOR</b>						
$f_{SW}$	Oscillator frequency	$3 V \leq V_{IN} \leq 6 V^{(1)}$	2	2.25	2.7	MHz
<b>OUTPUT</b>						
$t_{Start up}$	Start-up time	Activation time to start switching <sup>(2)</sup>		170		$\mu s$
$t_{Ramp}$	$V_{OUTx}$ ramp-up time	Time to ramp from 5% to 95% of $V_{OUTx}$		750		$\mu s$

(1) For  $V_{OUTx} > 2 V$ ,  $V_{IN min} = V_{OUTx} + 0.5 V$

(2) This time is valid if one converter turns from shutdown mode ( $EN2 = 0$ ) to active mode ( $EN2 = 1$ ) with the other converter already enabled (for example,  $EN1 = 1$ ). In case both converters are turned from shutdown mode ( $EN1$  and  $EN2 = 0$ ) to active mode ( $EN1$  and/or  $EN2 = 1$ ), a typical value of typ  $80 \mu s$  for ramp up of internal circuits must be added. After  $t_{Start}$ , the converter starts switching and ramps  $V_{OUTx}$ .

## 7.8 Typical Characteristics



图 7-1. TPS62407-Q1 Switching Frequency



图 7-2. TPS62407-Q1 Quiescent Current, One Converter On

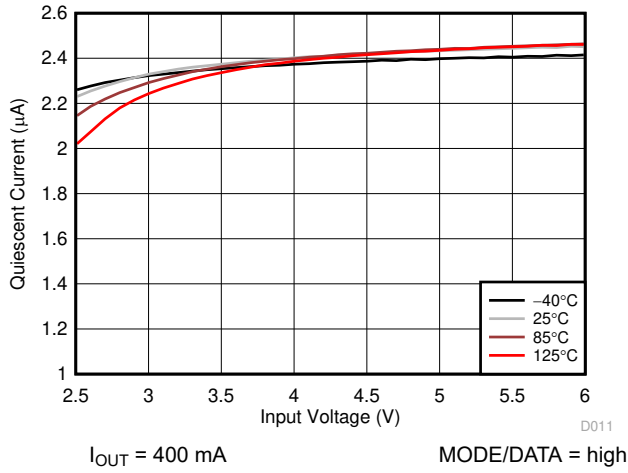

图 7-3. TPS62407-Q1 Quiescent Current, Both Converters On

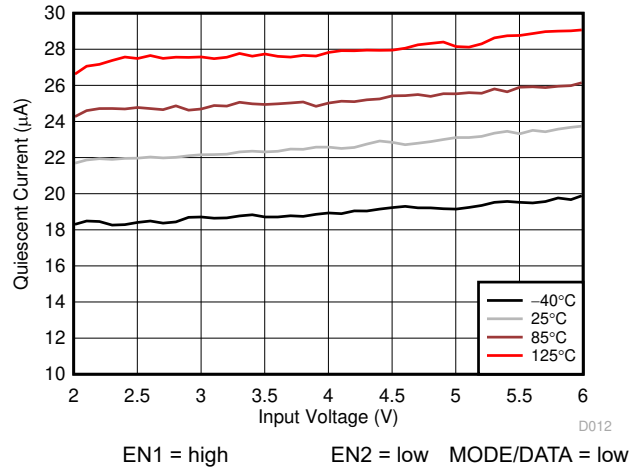

图 7-4.  $r_{\text{DS(on)}} \text{ PMOS vs } V_{\text{IN}}$

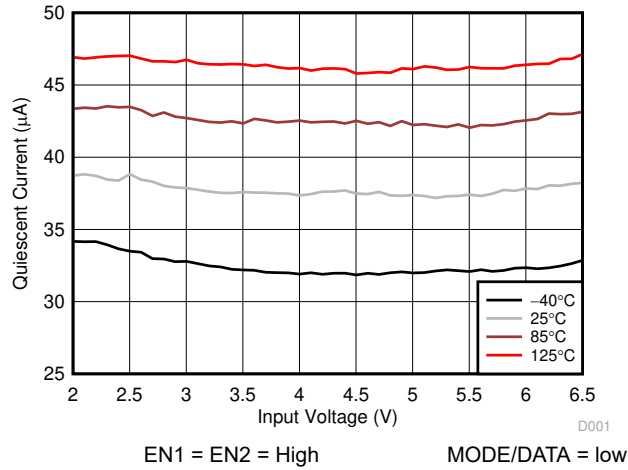

图 7-5.  $r_{\text{DS(on)}} \text{ NMOS vs } V_{\text{IN}}$

## 8 Detailed Description

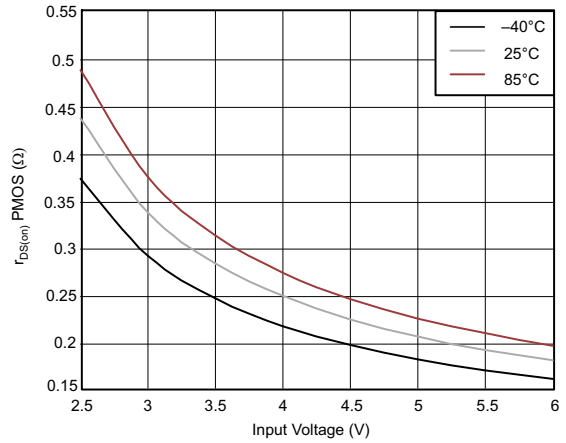
### 8.1 Overview

The TPS624xx-Q1 device includes two synchronous step-down converters. The converters operate with typically 2.25-MHz fixed-frequency pulse-width modulation (PWM) at moderate to heavy load currents. With the power-save mode enabled, the converters automatically enter power-save mode at light load currents and operate in PFM (pulse frequency modulation).

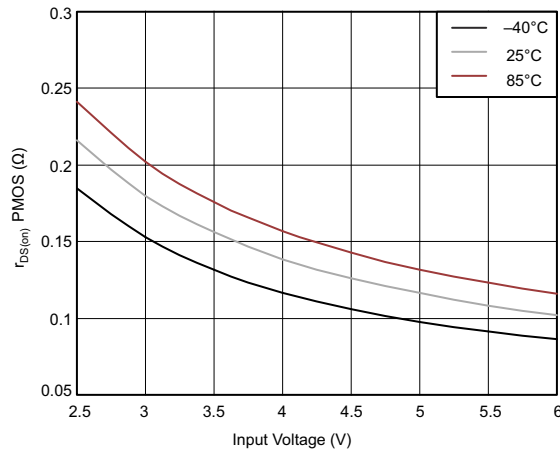
During PWM operation, the converters use a unique fast-response voltage-mode controller scheme with input-voltage feed-forward to achieve good line and load regulation, allowing the use of small ceramic input and output capacitors. At the beginning of each clock cycle initiated by the clock signal, the P-channel MOSFET switch turns on and the inductor current ramps up until the comparator trips and the control logic turns off the switch.

Each converter integrates two current limits, one in the P-channel MOSFET and another one in the N-channel MOSFET. When the current in the P-channel MOSFET reaches its current limit, the P-channel MOSFET turns off and the N-channel MOSFET turns on. If the current in the N-channel MOSFET is above the N-MOS current limit threshold, the N-channel MOSFET remains on until the current drops below its current limit.

The two DC-DC converters operate synchronized to each other. A 180° phase shift between converter 1 and converter 2 decreases the input rms current.

#### 8.1.1 Converter 1

It is possible to change the output voltage of converter 1 with the EasyScale serial Interface. This makes the device very flexible for output-voltage adjustment. In this case, the device uses an internal resistor network.

The output voltage can also be selected using the DEF\_1 pin configuration as a digital input. For these voltage version the DEF\_1 pin select the same output voltage for DEF\_1=high or DEF\_1=low.

#### 8.1.2 Converter 2

It is also possible to change the output voltage of converter 2 via the EasyScale interface.

## 8.2 Functional Block Diagram

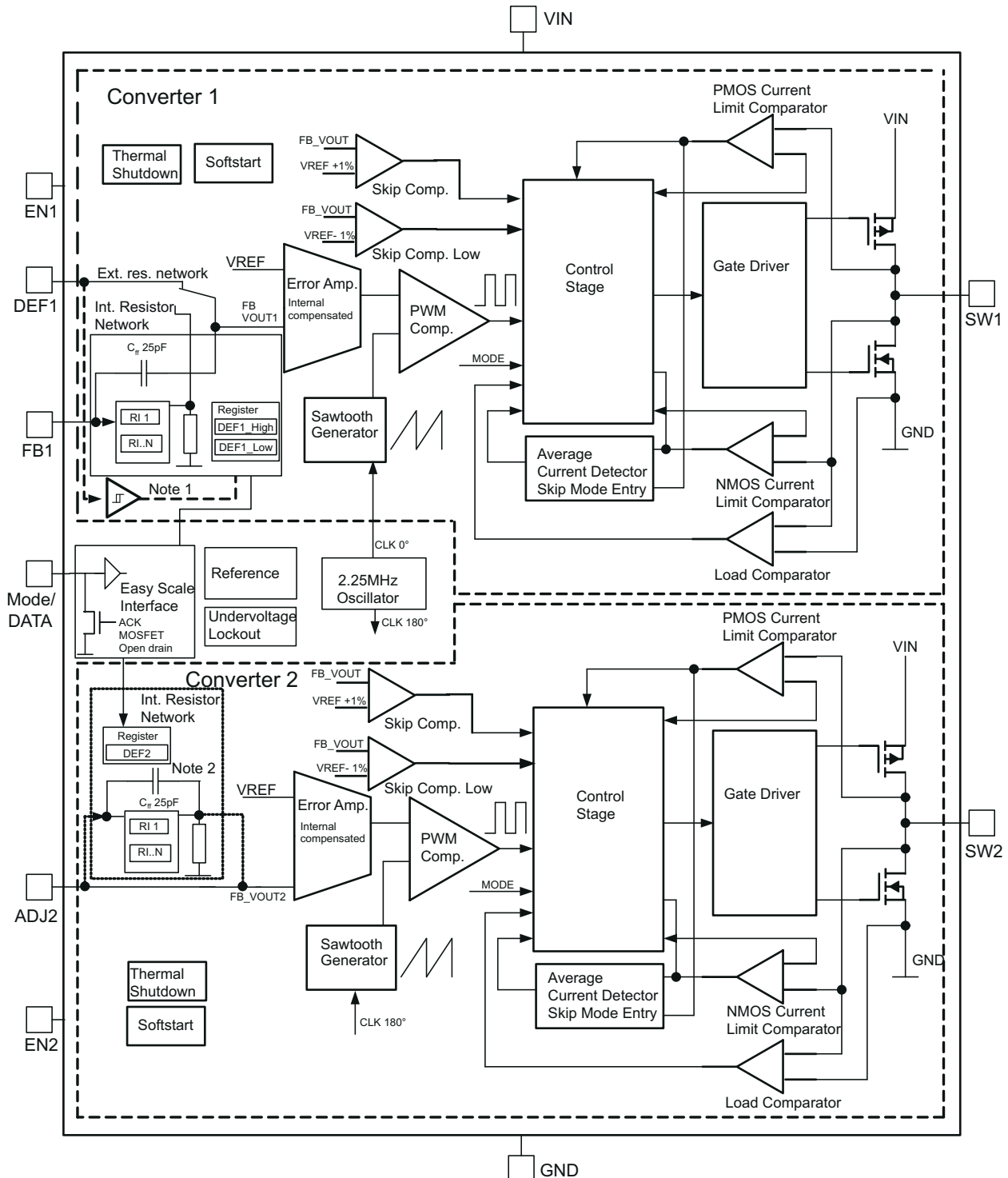

- A. In the fixed output-voltage version, the DEF\_1 pin connects to an internal digital input and disconnects from the error amplifier.
- B. To set the output voltage of converter 2 through the EasyScale™ interface, the ADJ2 pin must directly connect to V<sub>OUT2</sub>.

## 8.3 Feature Description

### 8.3.1 Enable

The device has a separate EN pin for each converter to start up each converter independently. If EN1 or EN2 is set to high, the corresponding converter starts up with soft start.

Pulling EN1 and EN2 pin low forces the device into shutdown, with a shutdown quiescent current of typically 1.2  $\mu$  A. In this mode, the P- and N-channel MOSFETs turn off and the entire internal control circuitry switches off. For proper operation, terminate the EN1 and EN2 pins, do not leave them floating.

### 8.3.2 DEF\_1 Pin Function

The DEF\_1 pin, dedicated to converter 1, makes the output voltage selection very flexible to support dynamic voltage management. Having this pin tied to a low level sets the output voltage according to the value in register REG\_DEF\_1\_Low. The default voltage is 1.125 V for TPS62406-Q1. Having the pin tied to a high level sets the output voltage according to the value in register REG\_DEF\_1\_High. The default value in this case is 1.125 V as well. The level of the DEF\_1 pin selects between the two registers, REG\_DEF\_1\_Low and REG\_DEF\_1\_High, for the output-voltage setting. One can change the content of each register (and therefore output voltage) individually through the EasyScale interface. This makes the device very flexible in terms of output voltage setting; see [表 8-3](#)

### 8.3.3 180° Out-of-Phase Operation

In PWM mode, the converters operate with a 180° turn-on phase shift of the PMOS (high side) transistors. This prevents the high-side switches of both converters from turning on simultaneously, reducing the input current ripple. This feature reduces the surge current drawn from the supply.

### 8.3.4 Short-Circuit Protection

Both outputs are short-circuit protected with maximum output current =  $I_{LIMF}$ (P-MOS and N-MOS). Once the PMOS switch reaches its current limit, it turns off and the NMOS switch turns on. The PMOS only turns on again once the current in the NMOS decreases below the NMOS current limit.

### 8.3.5 Thermal Shutdown

As soon as the junction temperature,  $T_J$ , exceeds 150°C (typical) the device goes into thermal shutdown. In this mode, the P- and N-channel MOSFETs turn off. The device continues its operation when the junction temperature falls below the thermal-shutdown hysteresis.

### 8.3.6 EasyScale Interface: One-Pin Serial Interface for Dynamic Output-Voltage Adjustment

#### 8.3.6.1 General

The EasyScale interface is a simple but very flexible one-pin interface to configure the output voltage of both DC-DC converters. A master-slave structure is the basis of the interface, where the master is typically a microcontroller or application processor. [图 8-3](#) and [表 8-2](#) give an overview of the protocol. The protocol consists of a device-specific address byte and a data byte. The device-specific address byte is fixed to 4E hex. The data byte consists of five bits for information, two address bits, and the RFA bit. The RFA bit set to high indicates the request-for-acknowledge condition. The acknowledge condition only applies after correct reception of the protocol.

The advantage of the EasyScale interface compared to other one-pin interfaces is that its bit detection is to a large extent independent from the bit transmission rate. It can automatically detect bit rates between 1.7 kb/s and up to 160 kb/s. Furthermore, the interface shares the MODE/DATA pin and requires no additional pin.

#### 8.3.6.2 Protocol

Transmission of all bits is MSB first and LSB last. [图 8-4](#) shows the protocol without the acknowledge request (bit RFA = 0), [图 8-5](#) with the acknowledge request (bit RFA = 1).

Prior to both bytes, device address byte and data byte, one must apply a start condition. For this, pull the MODE/DATA pin high for at least  $t_{Start}$  before the bit transmission starts with the falling edge. In case the MODE/DATA

line was already at a high level (forced PWM mode selection), the device requires no start condition prior to the device address byte.

Close the transmission of each byte with an end-of-stream condition for at least  $t_{EOS}$ .

## 8.4 Device Functional Modes

### 8.4.1 Power-Save Mode

Setting the MODE/DATA pin to low for both converters enables power-save mode. If the load current of a converter decreases, this converter enters power-save-mode operation automatically. The transition of a converter to power-save mode is independent from the operating condition of the other converter. During power-save mode, the converter operates with reduced switching frequency in PFM mode and with a minimum quiescent current to maintain high efficiency. The converter positions the output voltage in PFM mode to typically 1% above nominal  $V_{OUTx}$ . This voltage positioning feature minimizes voltage drops caused by a sudden load step.

In order to optimize the converter efficiency at light load, the device monitors average inductor current. The device changes from PWM mode to power-save mode if in PWM mode the inductor current falls below a certain threshold. The typical output current threshold, which one can calculate using [方程式 1](#) for each converter, depends on  $V_{IN}$ .

[方程式 1](#): Average output current threshold to enter PFM mode

$$I_{OUT\_PFM\_enter} = \frac{V_{IN\_DCDC}}{32 \Omega} \quad (1)$$

[方程式 2](#): Average output current threshold to leave PFM mode

$$I_{OUT\_PFM\_leave} = \frac{V_{IN\_DCDC}}{24 \Omega} \quad (2)$$

To keep the output-voltage ripple in power-save mode low, a single threshold comparator (skip comparator) monitors the output voltage. As the output voltage falls below the skip-comparator threshold (skip comp) of 1% above nominal  $V_{OUTx}$ , the corresponding converter starts switching for a minimum time period of typically 1  $\mu$ s and provides current to the load and the output capacitor. Therefore, the output voltage increases and the device maintains switching until the output voltage trips the skip comparator threshold (skip comp) again. At this moment, all switching activity stops and the quiescent current reduces to minimum. The output capacitor supplies the load until the output voltage has dropped below the threshold again. Hereupon, the device starts switching again.

The converter leaves power-save mode and enters PWM mode if the output current exceeds the  $I_{OUT\_PFM\_leave}$  current or if the output voltage falls below a second comparator threshold, called the skip-comparator-low (Skip Comp Low) threshold. This skip-comparator-low threshold is 2% below nominal  $V_{OUTx}$  and enables a fast transition from power-save mode to PWM mode during a load step.

Power-save mode typically reduces the quiescent current to 19  $\mu$ A for one converter and 32  $\mu$ A for both converters active. This single-skip comparator threshold method in power-save mode results in a very low output-voltage ripple. The ripple depends on the comparator delay and the size of the output capacitor. Increasing output capacitor values minimizes the output ripple. One can disable the power-save mode by setting the MODE/DATA pin to high. Both converters then operate in fixed PWM mode. Power-save mode enable or disable applies to both converters.

#### 8.4.1.1 Dynamic Voltage Positioning

This feature reduces the voltage under- and overshoots at load steps from light to heavy load and from heavy to light load. Power-save-mode operation activates dynamic voltage positioning and provides more headroom for both the voltage drop at a load step and the voltage increase when a load is switched off, which improves load-transient behavior.

At light loads, in which the converter operates in PFM mode, the output voltage regulation is typically 1% higher than the nominal value. In case of a load transient from light load to heavy load, the output voltage drops until it reaches the skip comparator low threshold set to 2% below the nominal value and enters PWM mode. During a load transition from heavy load to light load, the device also minimizes voltage overshoot because of active regulation turning on the N-channel switch.



图 8-1. Dynamic Voltage Positioning

#### 8.4.1.2 Soft Start

The two converters have an internal soft-start circuit that limits the inrush current during startup. 图 8-2 shows control of the output-voltage ramp-up during soft start.

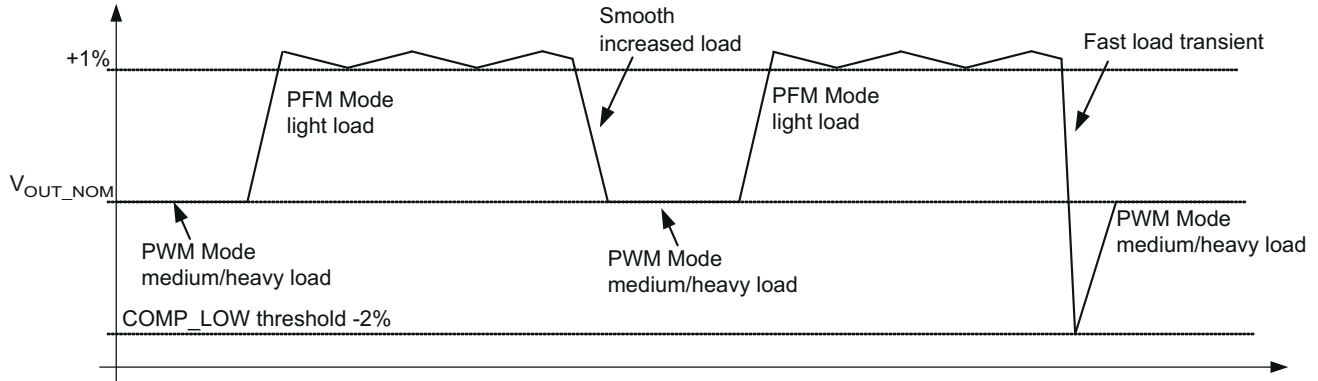

图 8-2. Soft Start

#### 8.4.1.3 100% Duty-Cycle Low-Dropout Operation

The converters offer a low input-to-output voltage difference while still maintaining operation with the use of the 100% duty-cycle mode. In this mode, the P-channel switch is constantly on. This is particularly useful in battery-powered applications to achieve longest operation time by taking full advantage of the whole battery-voltage range. The minimum input voltage to maintain regulation depends on the load current and output voltage, which one can calculate as:

$$V_{in_{min}} = V_{out_{max}} + I_{out_{max}} \times (R_{DS(on)_{max}} + R_L) \quad (3)$$

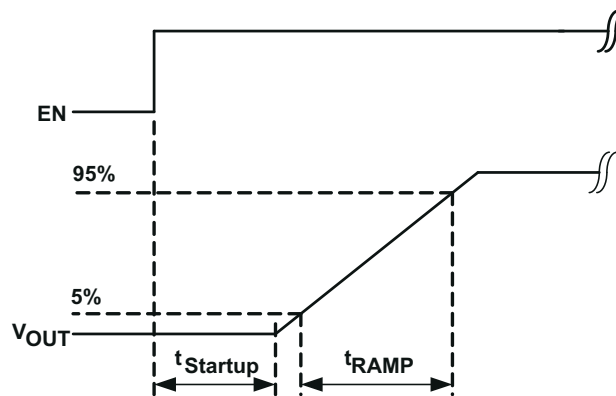
with

- $I_{OUTx_{max}}$  = maximum output current plus inductor ripple current
- $r_{DS(on)_{max}}$  = maximum P-channel switch  $r_{DS(on)}$
- $R_L$  = dc resistance of the inductor
- $V_{OUTx_{max}}$  = nominal output voltage plus maximum output-voltage tolerance

With decreasing load current, the device automatically switches into pulse-skipping operation, in which the power stage operates intermittently based on load demand. Running cycles periodically minimizes the switching losses, and the device runs with a minimum quiescent current, maintaining high efficiency.

#### 8.4.1.4 Undervoltage Lockout

The undervoltage lockout circuit prevents the device from malfunction at low input voltages and from excessive discharge of the battery, and disables the converters. The undervoltage lockout threshold is typically 1.5 V; maximum of 2.35 V. In case the interface overwrites the default register values, the new values in the registers REG\_DEF\_1\_High, REG\_DEF\_1\_Low and REG\_DEF\_2 remain valid as long the supply voltage does not fall below the undervoltage lockout threshold, independent of disabling of the converters.

#### 8.4.2 Mode Selection

The MODE/DATA pin allows mode selection between forced PWM mode and power-save mode for both converters. Furthermore, this pin is a multipurpose pin and provides (besides mode selection) a one-pin interface to receive serial data from a host to set the output voltage, as described in the [EasyScale Interface](#) section.

Connecting this pin to GND enables the automatic PWM and power-save-mode operation. The converters operate in fixed-frequency PWM mode at moderate-to-heavy loads, and in the PFM mode during light loads, maintaining high efficiency over a wide load-current range.

Pulling the MODE/DATA pin high forces both converters to operate constantly in the PWM mode, even at light load currents. The advantage is that the converters operate with a fixed frequency, allowing simple filtering of the switching frequency for noise-sensitive applications. In this mode, the efficiency is lower compared to the power-save mode during light loads. For additional flexibility, it is possible to switch from power-save mode to forced PWM mode during operation. This allows efficient power management by adjusting the operation of the converter to the specific system requirements.

In the case of changing the operation mode from forced PWM mode (MODE/DATA = high) to power-save mode (MODE/DATA = 0), enabling the power-save mode occurs after a delay time of  $t_{\text{timeout}}$ , which is 520  $\mu\text{s}$  maximum.

Setting the MODE/DATA to 1 enables forced-PWM-mode operation immediately.

### 8.5 Programming

#### 8.5.1 Addressable Registers

Three registers with a data content of 5 bits are addressable. With 5-bit data content, 32 different values for each register are available. [表 8-1](#) shows the addressable registers to set the output voltage when the DEF\_1 pin works as a digital input. In this case, converter 1 has a related register for each DEF\_1 pin condition, and one register for converter 2. A high or low condition on pin DEF\_1 selects either the content of register REG\_DEF\_1\_High or REG\_DEF\_1\_Low, thus setting the output voltage of converter 1 according to the values in Selectable Output Voltage Converter 1, With Pin DEF\_1 as Digital Input. Use of a precise internal resistor divider network to generate these output voltages makes external resistors unnecessary (less board space) and provides higher output-voltage accuracy. Enabling at least one of the converters (EN1 or EN2 is high) activates the interface. After the startup time  $t_{\text{Start}}$  (170  $\mu\text{s}$ ), the interface is ready for data reception.

**表 8-1. Addressable Registers for Default Fixed-Output Voltage Options (PIN DEF\_1 = Digital Input)**

DEVICE	REGISTER	DESCRIPTION	DEF_1 PIN	A1	A0	D4	D3	D2	D1	D0
TPS624xx-Q1 ,	REG_DEF_1_High	Converter 1 output voltage setting for DEF_1 = High condition. The content of the register is active with the DEF_1 pin high.	High	0	1	Output voltage setting, see <a href="#">表 8-3</a>				
	REG_DEF_1_Low	Converter 1 output voltage setting for DEF_1 = Low condition.	Low	0	0	Output voltage setting, see <a href="#">表 8-3</a>				
	REG_DEF_2	Converter 2 output voltage	Not applicable	1	0	Output voltage setting, see <a href="#">表 8-4</a>				
		Do not use		1	1					

### 8.5.1.1 Bit Decoding

The bit detection is based on a PWM scheme, where the criterion is the relation between the low time and high time of the low or high bit ( $t_{L\_xB}$  and  $t_{H\_xB}$ ). Bit detection can be simplified to:

High bit:  $t_{H\_HB} > t_{L\_HB}$ , but with  $t_{H\_HB}$  at least  $2 \times t_{L\_HB}$ , see [图 8-3](#).

Low bit:  $t_{L\_LB} > t_{H\_LB}$ , but with  $t_{L\_LB}$  at least  $2 \times t_{H\_LB}$ , see [图 8-3](#).

The bit detection starts with a falling edge on the MODE/DATA pin and ends with the next falling edge. Detection of a 0 or 1 depends on the relation between  $t_{L\_xB}$  and  $t_{H\_xB}$ .

### 8.5.1.2 Acknowledge

The device only applies the acknowledge condition if all of the following occurs:

- A set RFA bit requests an acknowledge
- The transmitted device address matches with the device address of the device
- Correct reception of 16 bits occurred

In this case, the device turns on the internal ACKN-MOSFET and pulls the MODE/DATA pin low for the time  $t_{ACKN}$ , which is 520  $\mu$ s maximum. The acknowledge condition is valid after an internal delay time  $t_{valACK}$ . This means the internal ACKN-MOSFET turns on after  $t_{valACK}$ , on detection of the last falling edge of the protocol. The master controller keeps the line low during this time.

The master device can detect the acknowledge condition with its input by releasing the MODE/DATA pin after  $t_{valACK}$  and reading back a 0.

In case of an invalid device address, or not-correctly-received protocol, application of a no-acknowledge condition does not occur; thus, the internal MOSFET does not turn on, and the external pullup resistor pulls the MODE/DATA pin high after  $t_{valACK}$ . One can use the MODE/DATA pin again after the acknowledge condition ends.

#### 备注

The master device must have an open-drain output in order to request the acknowledge condition.

In case of a push-pull output stage, TI recommends using a series resistor in the MODE/DATA line to limit the current to 500  $\mu$ A in case of an accidentally requested acknowledge, to protect the internal ACKN-MOSFET.

### 8.5.1.3 Mode Selection

Use of the MODE/DATA pin for two functions, interface and mode selection, necessitates a determination of when to decode the bit stream or to change the operation mode.

The device enters forced PWM mode operation immediately whenever the MODE/DATA pin turns to high level. The device also stays in forced PWM mode during the entire protocol reception time.

With a falling edge on the MODE/DATA pin, the device starts bit decoding. If the MODE/DATA pin stays low for at least  $t_{timeout}$ , the device gets an internal time-out and enables power-save-mode operation.

The device ignores a protocol sent within this time because the first interpretation of a falling edge for the mode change is at the start of the first bit. In this case, TI recommends sending the protocol first, and then changing to power-save mode at the end of the protocol.



图 8-3. EasyScale Protocol Overview

表 8-2. EasyScale Bit Description

BYTE	BIT NUMBER	NAME	TRANSMISSION DIRECTION	DESCRIPTION
Device address byte  4E hex	7	DA7	IN	0 MSB device address
	6	DA6	IN	1
	5	DA5	IN	0
	4	DA4	IN	0
	3	DA3	IN	1
	2	DA2	IN	1
	1	DA1	IN	1
	0	DA0	IN	0 LSB device address
Data byte	7 (MSB)	RFA	IN	Request for acknowledge; if high, the device applies an acknowledge condition.
	6	A1		Address bit 1
	5	A0		Address bit 0
	4	D4		Data bit 4
	3	D3		Data bit 3
	2	D2		Data bit 2
	1	D1		Data bit 1
	0 (LSB)	D0		Data bit 0
		ACK	OUT	Acknowledge condition active 0, the device applies this condition only in the case of a set RFA bit. Open-drain output, the host must pull the line high with a pullup resistor.  One can only use this feature if the master has an open-drain output stage. In case of a push-pull output stage, do not request an acknowledge condition.

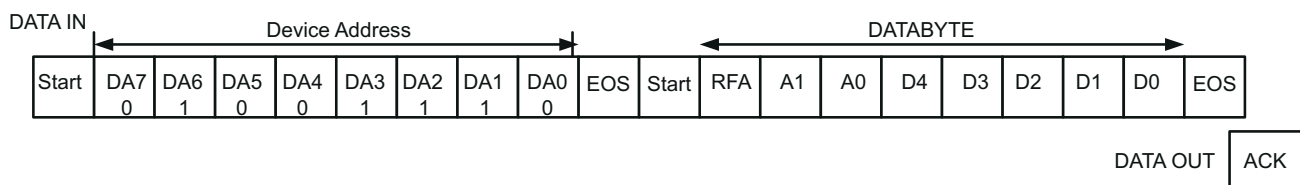

图 8-4. EasyScale Protocol Without Acknowledge



图 8-5. EasyScale Protocol Including Acknowledge

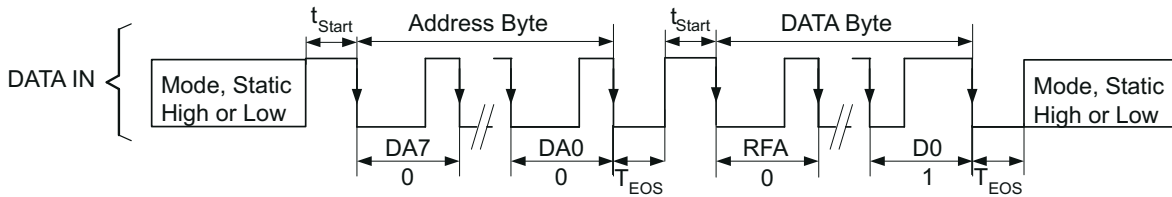

图 8-6. EasyScale - Bit Coding

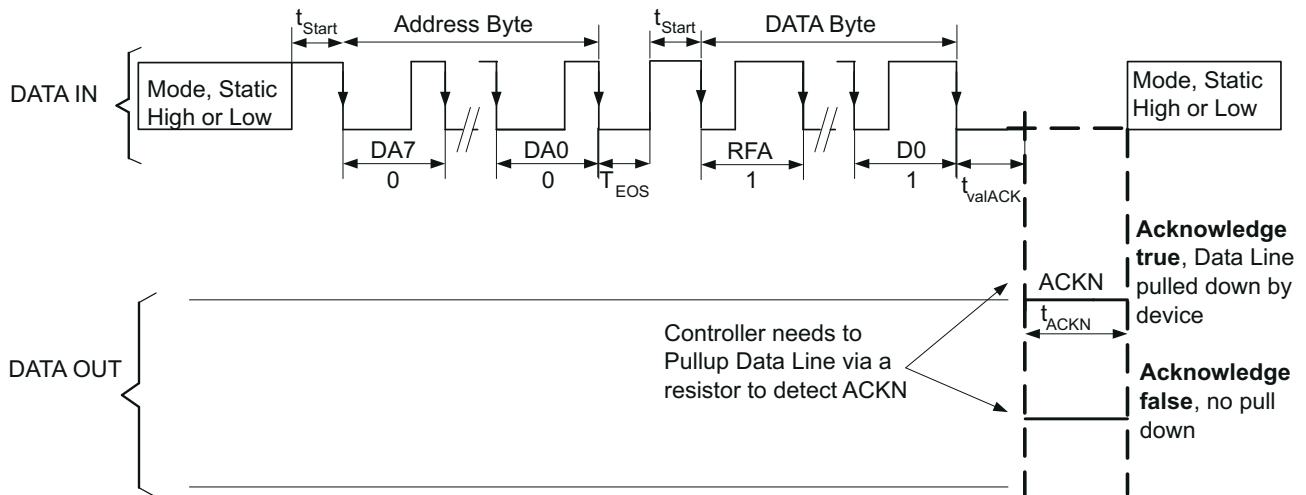

图 8-7. MODE/DATA PIN: Mode Selection

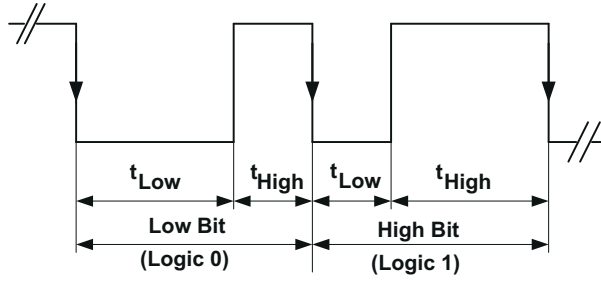

图 8-8. MODE/DATA Pin: Power-Save-Mode and Interface Communication

**表 8-3. Selectable Output Voltages for Converter 1,  
With Pin DEF\_1 as Digital Input**

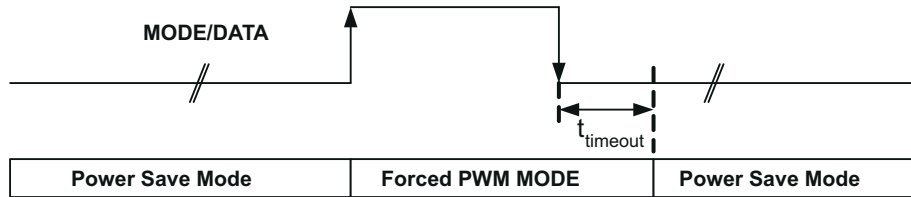
	TPS624xx-Q1 OUTPUT VOLTAGE [V] REGISTER REG_DEF_1_LOW	TPS624xx-Q1 VOLTAGE [V] REGISTER REG_DEF_1_HIGH	D4	D3	D2	D1	D0
0	0.8	0.9	0	0	0	0	0
1	0.825	0.925	0	0	0	0	1
2	0.85	0.95	0	0	0	1	0
3	0.875	0.975	0	0	0	1	1
4	0.9	1.0	0	0	1	0	0
5	0.925	1.025	0	0	1	0	1
6	0.95	1.050	0	0	1	1	0
7	0.975	1.075	0	0	1	1	1
8	1.0	1.1	0	1	0	0	0
9	1.025	1.125	0	1	0	0	1
10	1.050	1.150	0	1	0	1	0
11	1.075	1.175	0	1	0	1	1
12	1.1	1.2	0	1	1	0	0
13	1.125	1.225	0	1	1	0	1
14	1.150	1.25	0	1	1	1	0
15	1.175	1.275	0	1	1	1	1
16	1.2	1.3	1	0	0	0	0
17	1.225	1.325	1	0	0	0	1
18	1.25	1.350	1	0	0	1	0
19	1.275	1.375	1	0	0	1	1
20	1.3	1.4	1	0	1	0	0
21	1.325	1.425	1	0	1	0	1
22	1.350	1.450	1	0	1	1	0
23	1.375	1.475	1	0	1	1	1
24	1.4	1.5	1	1	0	0	0
25	1.425	1.525	1	1	0	0	1
26	1.450	1.55	1	1	0	1	0
27	1.475	1.575	1	1	0	1	1
28	1.5	1.6	1	1	1	0	0
29	1.525	1.7	1	1	1	0	1
30	1.55	1.8	1	1	1	1	0
31	1.575	1.9	1	1	1	1	1

**表 8-4. Selectable Output Voltages for Converter 2,  
 (ADJ2 Connected to V<sub>OUT2</sub>)**

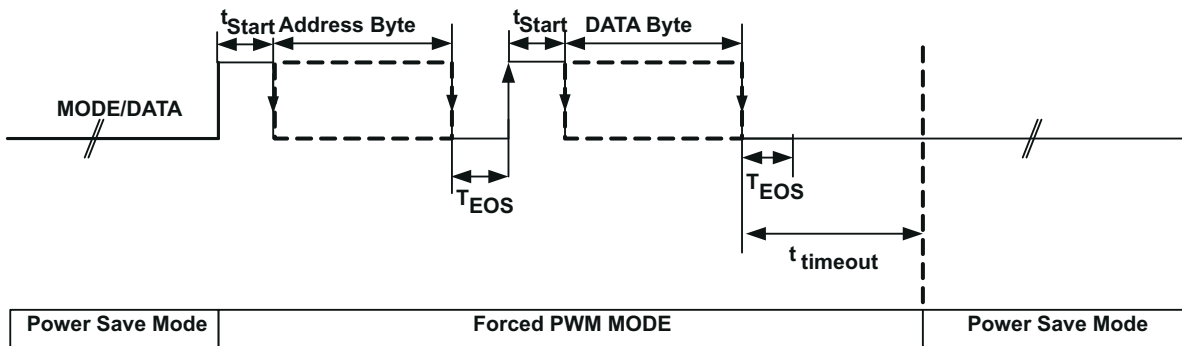
	OUTPUT VOLTAGE [V] FOR REGISTER REG_DEF_2	D4	D3	D2	D1	D0
<b>0</b>	<b>0.6</b>	<b>0</b>	<b>0</b>	<b>0</b>	<b>0</b>	<b>0</b>
1	0.85	0	0	0	0	1
2	0.9	0	0	0	1	0
3	0.95	0	0	0	1	1
4	1	0	0	1	0	0
5	1.05	0	0	1	0	1
6	1.1	0	0	1	1	0
7	1.15	0	0	1	1	1
8	1.2	0	1	0	0	0
9	1.25	0	1	0	0	1
10	1.3	0	1	0	1	0
11	1.35	0	1	0	1	1
12	1.4	0	1	1	0	0
13	1.45	0	1	1	0	1
14	1.5	0	1	1	1	0
15	1.55	0	1	1	1	1
16	1.6	1	0	0	0	0
17	1.7	1	0	0	0	1
18	1.8	1	0	0	1	0
19	1.85	1	0	0	1	1
20	2	1	0	1	0	0
21	2.1	1	0	1	0	1
22	2.2	1	0	1	1	0
23	2.3	1	0	1	1	1
24	2.4	1	1	0	0	0
25	2.5	1	1	0	0	1
26	2.6	1	1	0	1	0
27	2.7	1	1	0	1	1
28	2.8	1	1	1	0	0
29	2.85	1	1	1	0	1
30	3	1	1	1	1	0
31	3.3	1	1	1	1	1

## 9 Application and Implementation

### 备注

以下应用部分中的信息不属于 TI 器件规格的范围，TI 不担保其准确性和完整性。TI 的客户应负责确定器件是否适用于其应用。客户应验证并测试其设计，以确保系统功能。

### 9.1 Application Information

#### 9.1.1 Application Information

The TPS624xx-Q1 family of devices are synchronous dual step-down DC-DC converters. The devices provide two independent output voltage rails. The following information provides guidance on selecting external components to complete the application design.

#### 9.2 Typical Application



图 9-1. Typical Application Schematic

#### 9.2.1 Design Requirements

The step-down converter design can be adapted to different output voltage and load current needs. The following design procedure is adequate for whole  $V_{IN}$ ,  $V_{OUTx}$  and load current range of the TPS624xx-Q1 family of devices.

#### 9.2.2 Detailed Design Procedure

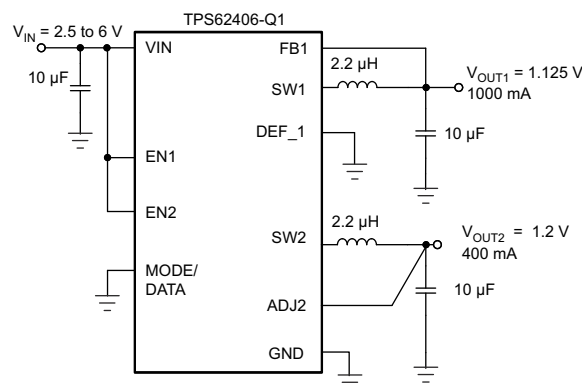
##### 9.2.2.1 Output Voltage Setting

##### 9.2.2.1.1 Converter 1 Fixed Default Output-Voltage Setting

The DEF\_1 pin selects output voltage  $V_{OUT1}$ .

##### Pin DEF\_1 = low:

- TPS62406-Q1, TPS62407-Q1 = 1.125 V
- TPS62422-Q1 = 1.15V
- TPS62423-Q1 = 1.2V
- TPS62424-Q1 = 1.1V

##### Pin DEF\_1 = high:

- TPS62406-Q1 = 1.125 V
- TPS62407-Q1 = 1.225 V
- TPS62422-Q1 = 1.8V
- TPS62423-Q1 = 1.5V
- TPS62424-Q1 = 1.3V

### 9.2.2.1.2 Converter 2 Fixed Default Output-Voltage Setting

ADJ2 pin must be directly connected with  $V_{OUT2}$ :

- TPS62406-Q1,  $V_{OUT2}$  default = 1.2 V
- TPS62407-Q1,  $V_{OUT2}$  default = 1.85 V
- TPS62422-Q1,  $V_{OUT2}$  default = 1.2 V
- TPS62423-Q1,  $V_{OUT2}$  default = 1.8 V
- TPS62424-Q1,  $V_{OUT2}$  default = 1.8 V

### 9.2.2.2 Output Filter Design (Inductor and Output Capacitor)

The converters operate with a minimum inductance of 1.75  $\mu$ H and minimum capacitance of 6  $\mu$ F. The device operation is optimum with inductors of 2.2  $\mu$ H to 4.7  $\mu$ H and output capacitors of 10  $\mu$ F to 22  $\mu$ F.

#### 9.2.2.2.1 Inductor Selection

Select the inductor based on its ratings for dc resistance and saturation current. The dc resistance of the inductor directly influences the efficiency of the converter. Therefore, select an inductor with lowest dc resistance for highest efficiency.

方程式 4 calculates the maximum inductor current under static load conditions. The saturation-current rating of the inductor should be higher than the maximum inductor current as calculated with 方程式 5. TI makes this recommendation because during heavy load transients the inductor current rises above the calculated value.

$$\Delta I_L = V_{out} \times \frac{1 - \frac{V_{out}}{V_{in}}}{L \times f} \quad (4)$$

where

- $\Delta I_L$  = Peak-to-peak inductor ripple current
- L = Inductor value
- f = Switching frequency (2.25 MHz typical)

$$I_{Lmax} = I_{outmax} + \frac{\Delta I_L}{2} \quad (5)$$

where

- $I_{Lmax}$  = Maximum inductor current  
and the highest inductor current occurs at maximum  $V_{IN}$ .

Open-core inductors have a soft saturation characteristic and they can usually handle higher inductor currents versus a comparable shielded inductor.

A more conservative approach is to select the inductor current rating just for the maximum switch current of the corresponding converter. Take into consideration that the core material from inductor to inductor differs, and this difference has an impact on the efficiency.

See 表 9-1 and the typical application circuit examples for possible inductors.

表 9-1. List of Inductors

DIMENSIONS [mm]	INDUCTOR TYPE	SUPPLIER
3.2 × 2.6 × 1	MIPW3226	FDK
3 × 3 × 0.9	LPS3010	Coilcraft
2.8 × 2.6 × 1	VLF3010	TDK
2.8 × 2.6 × 1.4	VLF3014	TDK
3 × 3 × 1.4	LPS3015	Coilcraft

**表 9-1. List of Inductors (continued)**

DIMENSIONS [mm]	INDUCTOR TYPE	SUPPLIER
3.9 × 3.9 × 1.7	LPS4018	Coilcraft

#### 9.2.2.2.2 Output-Capacitor Selection

The advanced fast-response voltage-mode control scheme of the converters allows the use of tiny ceramic capacitors with a typical value of 10  $\mu$ F to 22  $\mu$ F, without having large output-voltage under- and overshoots during heavy load transients. Ceramic capacitors with low ESR values result in lowest output-voltage ripple, and TI therefore recommends them. The output capacitor requires either X7R or X5R dielectric. TI does not recommend Y5V and Z5U dielectric capacitors because of their wide variation in capacitance.

If using ceramic output capacitors, the capacitor rms ripple-current rating always meets the application requirements. The rms ripple current calculation is:

$$I_{\text{RMS}C_{\text{out}}} = V_{\text{out}} \times \frac{1 - \frac{V_{\text{out}}}{V_{\text{in}}}}{L \times f} \times \frac{1}{2 \times \sqrt{3}} \quad (6)$$

At nominal load current, the inductive converters operate in PWM mode and the overall output voltage ripple is the sum of the voltage spike caused by the output capacitor ESR, plus the voltage ripple caused by charging and discharging the output capacitor:

$$\Delta V_{\text{out}} = V_{\text{out}} \times \frac{1 - \frac{V_{\text{out}}}{V_{\text{in}}}}{L \times f} \times \left( \frac{1}{8 \times C_{\text{out}} \times f} + \text{ESR} \right) \quad (7)$$

where

- The highest output-voltage ripple occurs at the highest input voltage,  $V_{\text{IN}}$ .

At light load currents, the converters operate in power-save mode and the output-voltage ripple depends on the output-capacitor value. The internal comparator delay and the external capacitor set the output-voltage ripple. Higher output capacitors like 22  $\mu$ F values minimize the voltage ripple in PFM mode and tighten dc output accuracy in PFM mode.

#### 9.2.2.2.3 Input Capacitor Selection

Because of the nature of the buck converter having a pulsating input current, the device requires a low-ESR input capacitor to prevent large voltage transients that can cause misbehavior of the device or interference with other circuits in the system. An input capacitor of 10  $\mu$ F is sufficient.

### 9.2.3 Application Curves

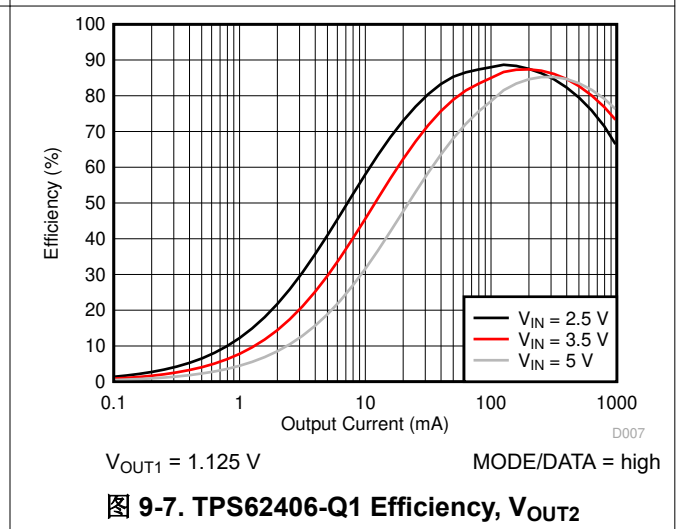
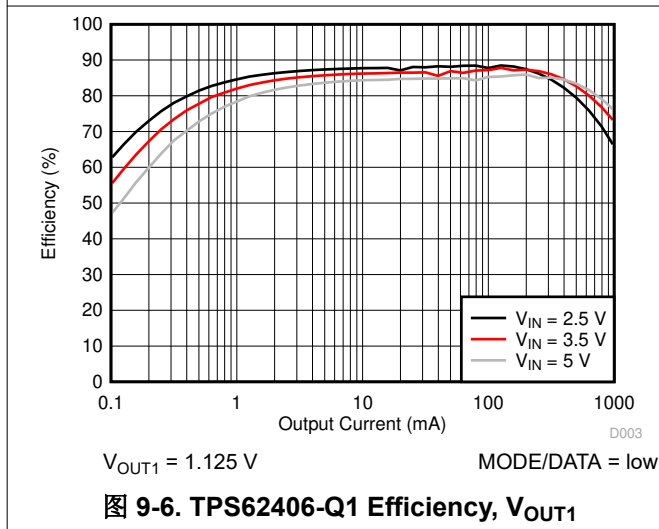
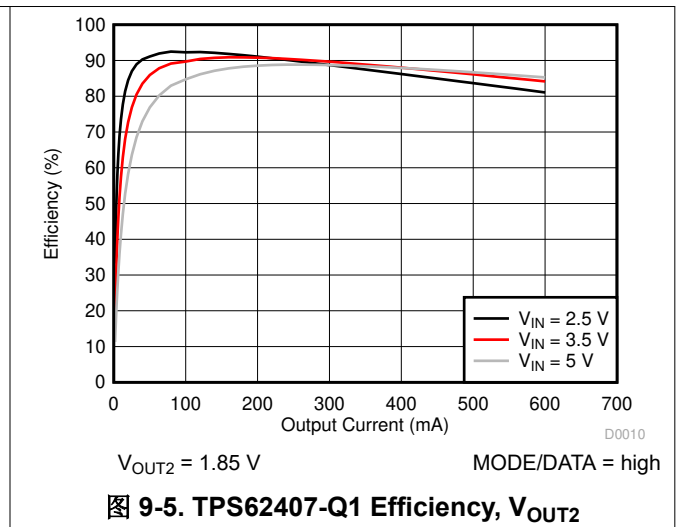
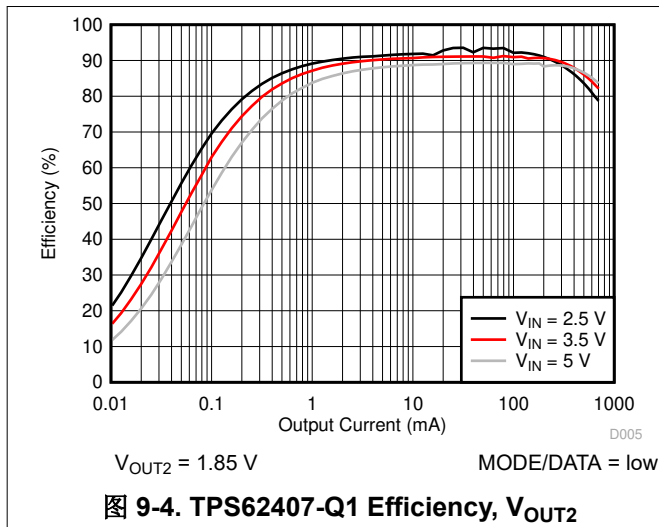
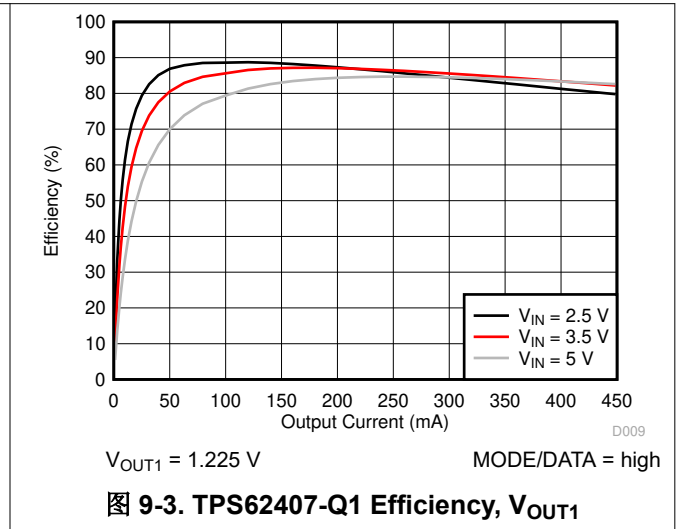
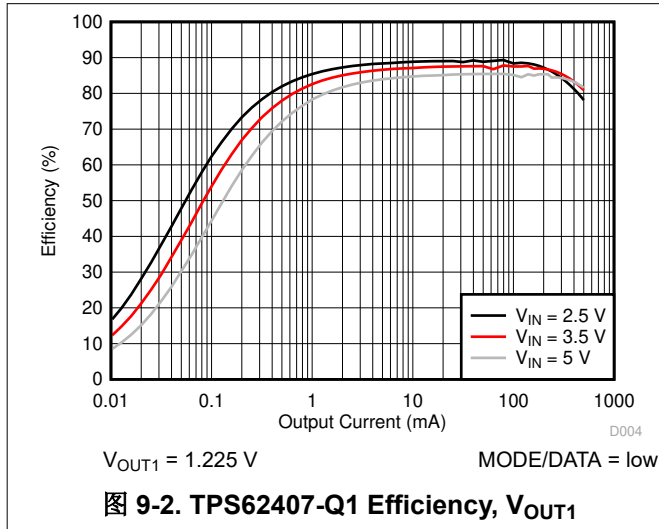



图 9-8. TPS62406-Q1 Efficiency,  $V_{OUT2}$



图 9-9. TPS62406-Q1 Efficiency,  $V_{OUT2}$

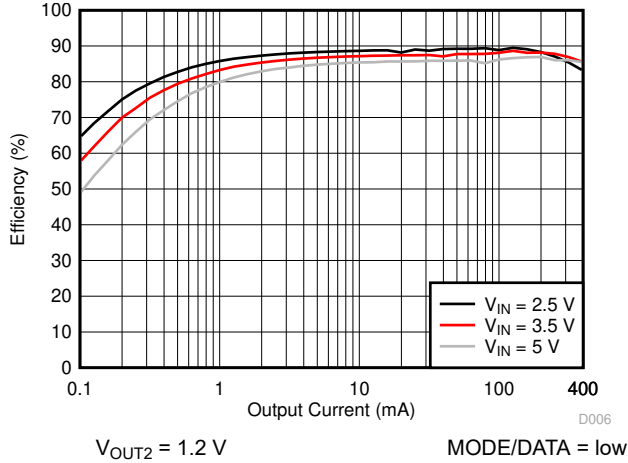

图 9-10. TPS62422-Q1  $V_{OUT1}$  vs.  $I_{OUT1}$

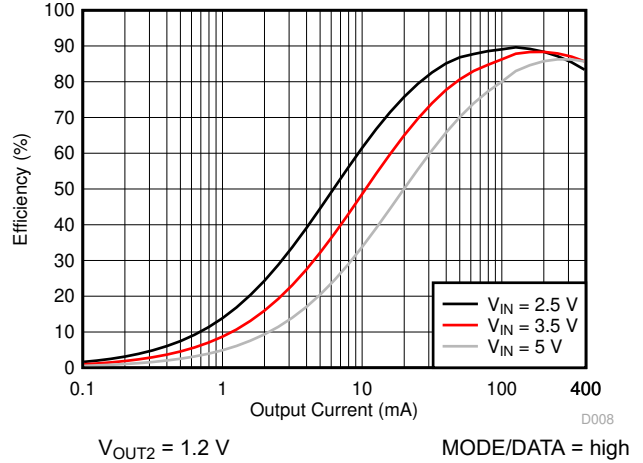

图 9-11. TPS62422-Q1  $V_{OUT1}$  vs.  $I_{OUT1}$

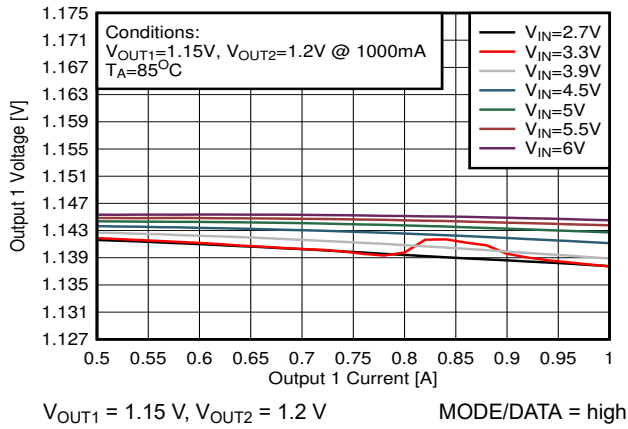

图 9-12. TPS62422-Q1  $V_{OUT2}$  vs.  $I_{OUT2}$

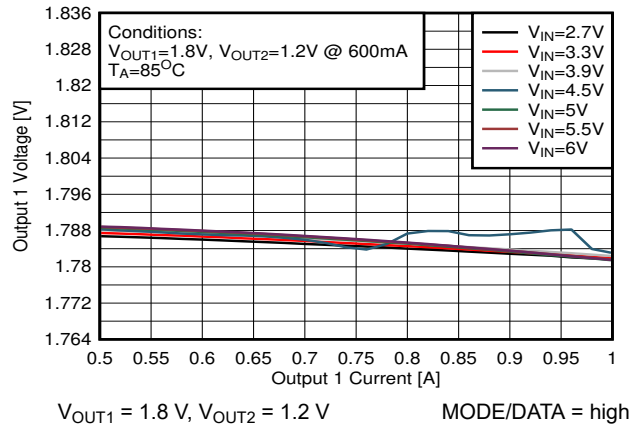

图 9-13. Light-Load Output-Voltage Ripple in Power-Save Mode

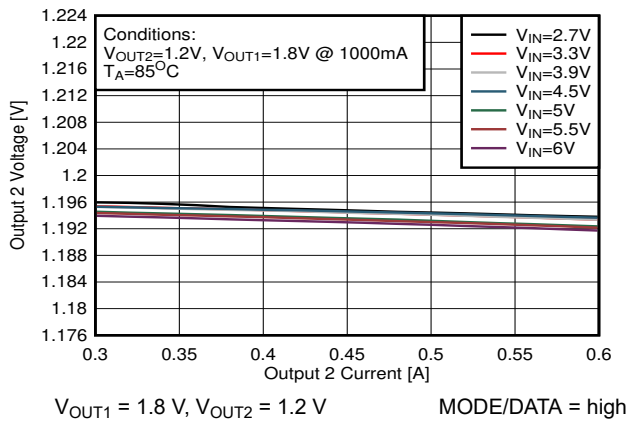

图 9-14. Output-Voltage Ripple in Forced-PWM Mode

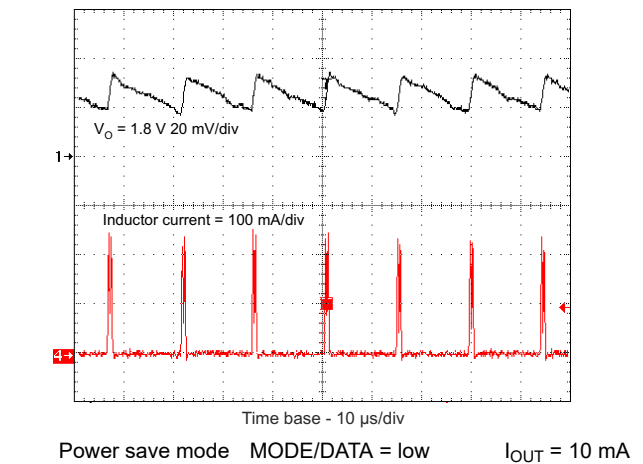

图 9-15. Output-Voltage Ripple in PWM Mode

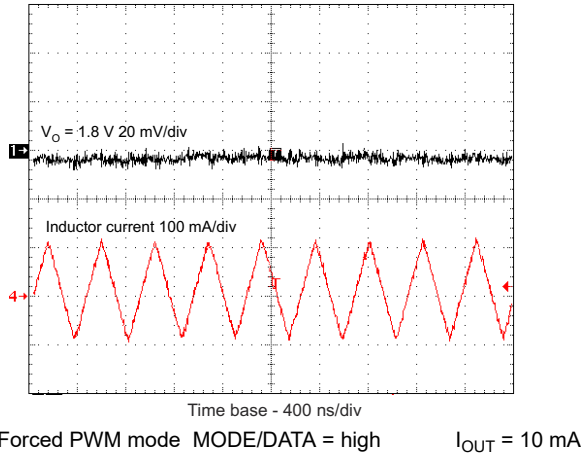

图 9-16. Forced PWM-to-PFM Mode Transition

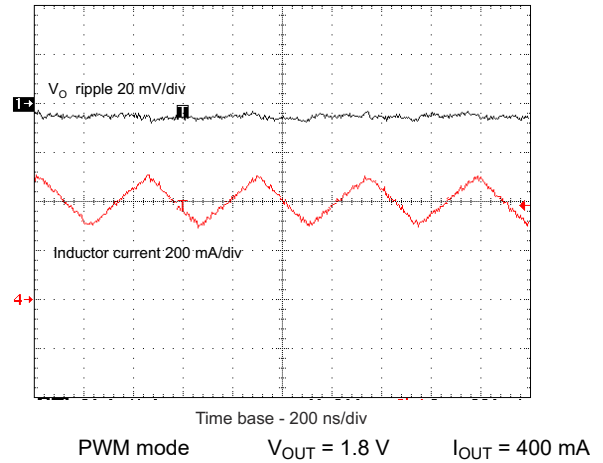

图 9-17. Load-Transient Response, PFM-to-PWM

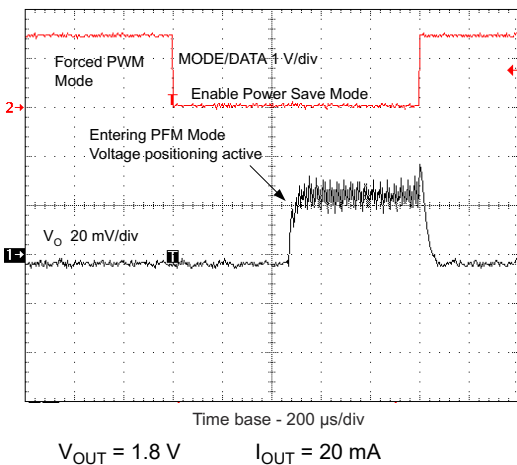

图 9-18. Load-Transient Response, PWM Operation

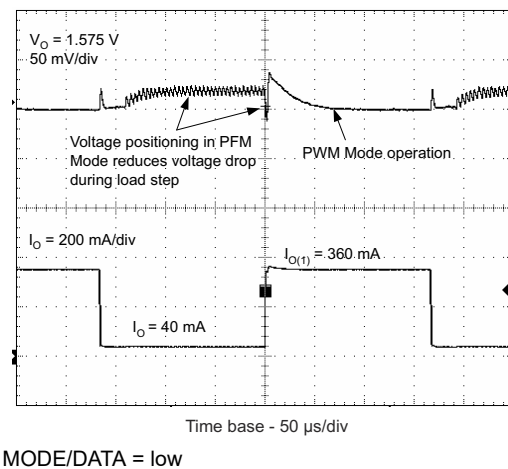

图 9-19. Line-Transient Response

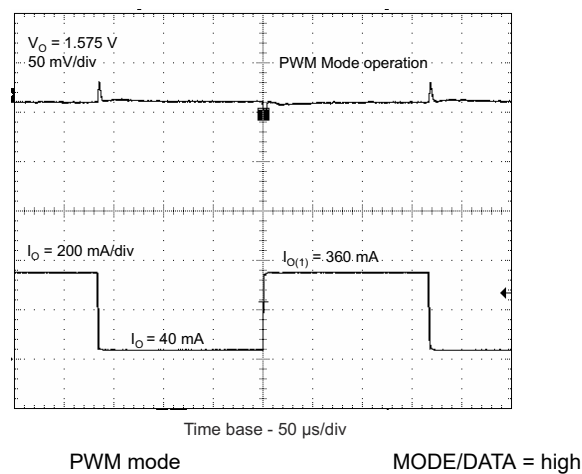

### 9.3 System Examples

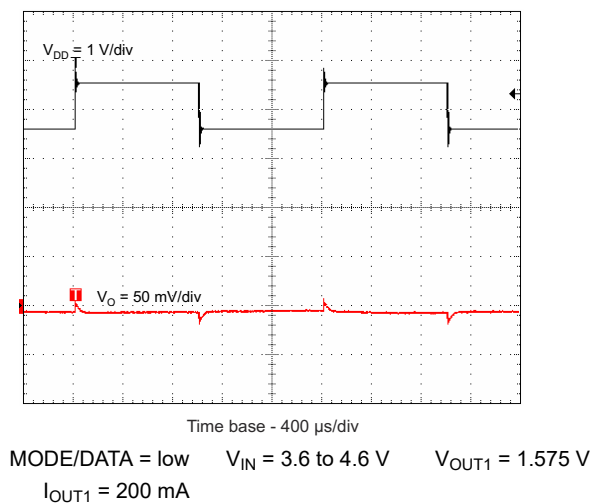
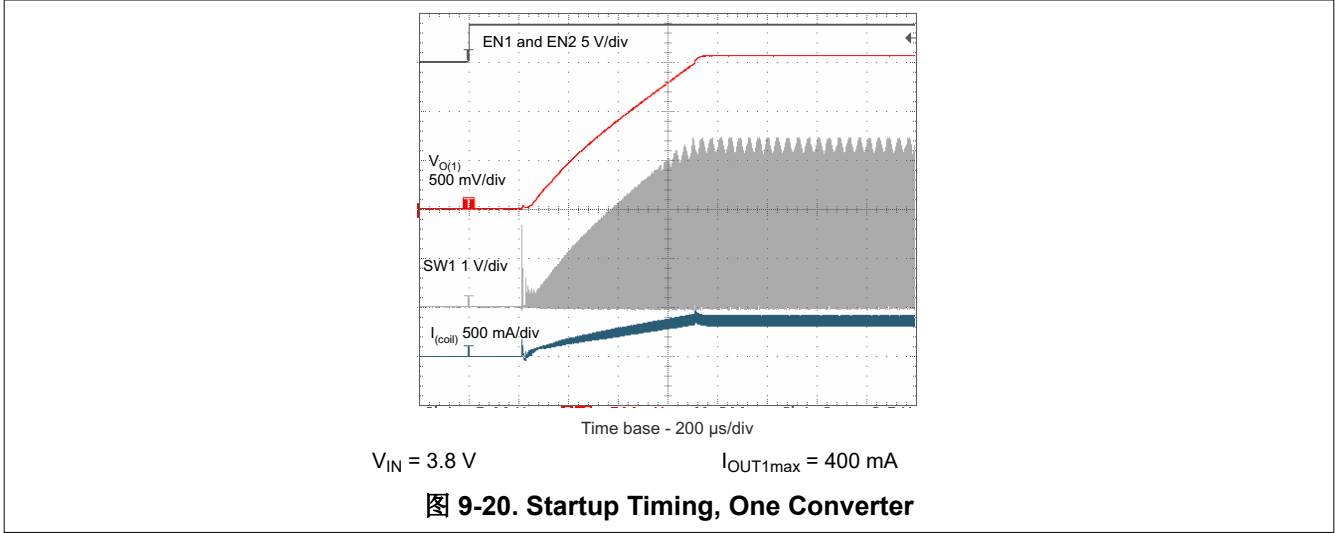
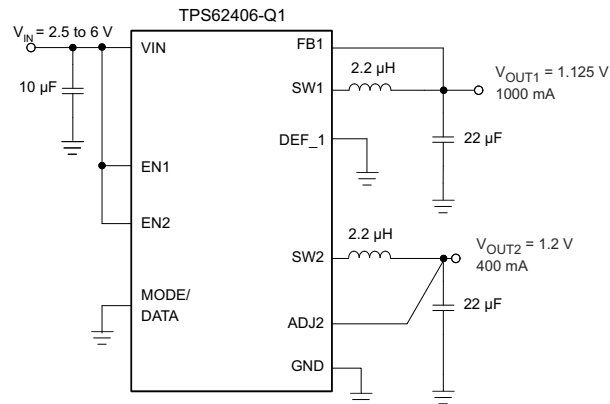

**图 9-21. TPS62406-Q1 Fixed 1.125-V and 1.2-V Outputs**



图 9-22. TPS62407-Q1 Fixed 1.225-V and 1.85-V Outputs



图 9-23. TPS62422-Q1 Fixed 1.15-V and 1.2-V Outputs

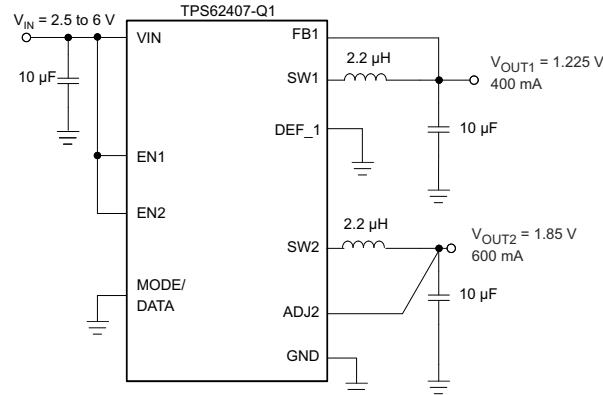

图 9-24. TPS62422-Q1 Fixed 1.8-V and 1.2-V Outputs

## 10 Power Supply Recommendations

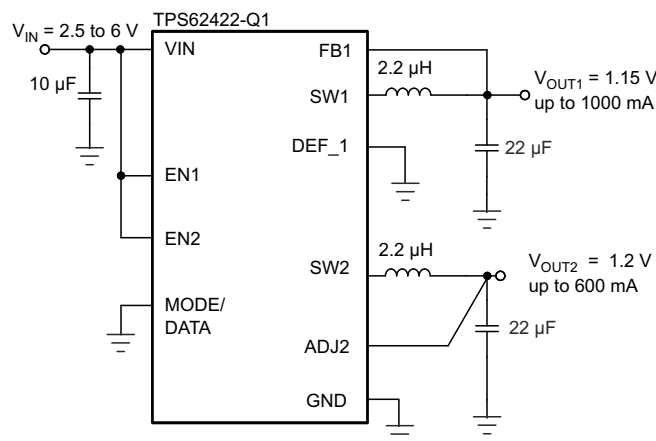
This device has no special recommendation for the power supply. TI recommends to use the values listed in the [# 7.3](#) table.

## 11 Layout

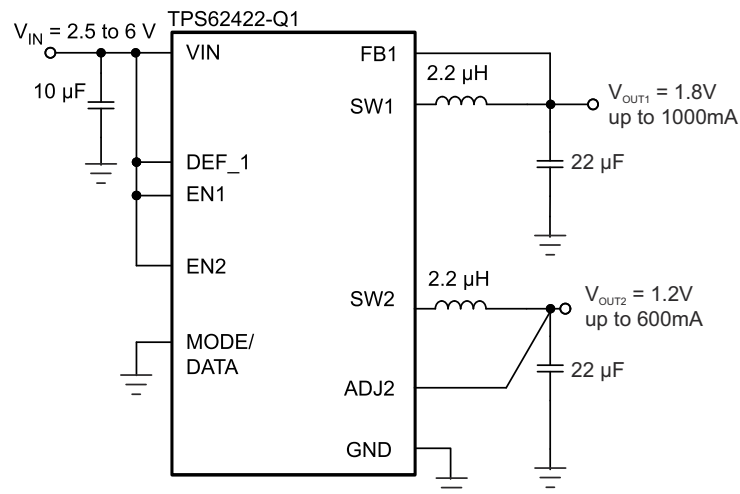
### 11.1 Layout Guidelines

- As for all switching power supplies, the layout is an important step in the design. Proper function of the device demands careful attention to PCB layout.
- It is critical to provide a low-inductance, low-impedance ground path. Therefore, use wide and short traces for the main current paths as indicated in bold in [图 11-1](#).
- Place the input capacitor as close as possible to the IC pins VIN and GND, the inductor and output capacitor as close as possible to the pins SW1 and GND.
- Connect the GND pin of the device to the PowerPAD of the PCB and use this pad as a star point. For each converter, use a common power GND node and a different node for the signal GND to minimize the effects of ground noise.
- Connect these ground nodes together to the PowerPAD (star point) underneath the IC. Keep the common path to the GND PIN, which returns the small signal components and the high current of the output capacitors, as short as possible to avoid ground noise.
- Connect the output voltage-sense lines (FB 1, DEF\_1, ADJ2) right to the output capacitor and route them away from noisy components and traces (for example, the SW1 and SW2 lines).
- If operating the EasyScale interface with high transmission rates, route the MODE/DATA trace away from the ADJ2 line to avoid capacitive coupling into the ADJ2 pin.
- A GND guard ring between the MODE/DATA pin and ADJ2 pin avoids potential noise coupling.

### 11.2 Layout Example



图 11-1. Layout Diagram

## 12 Device and Documentation Support

### 12.1 支持资源

TI E2E™ 支持论坛是工程师的重要参考资料，可直接从专家获得快速、经过验证的解答和设计帮助。搜索现有解答或提出自己的问题可获得所需的快速设计帮助。

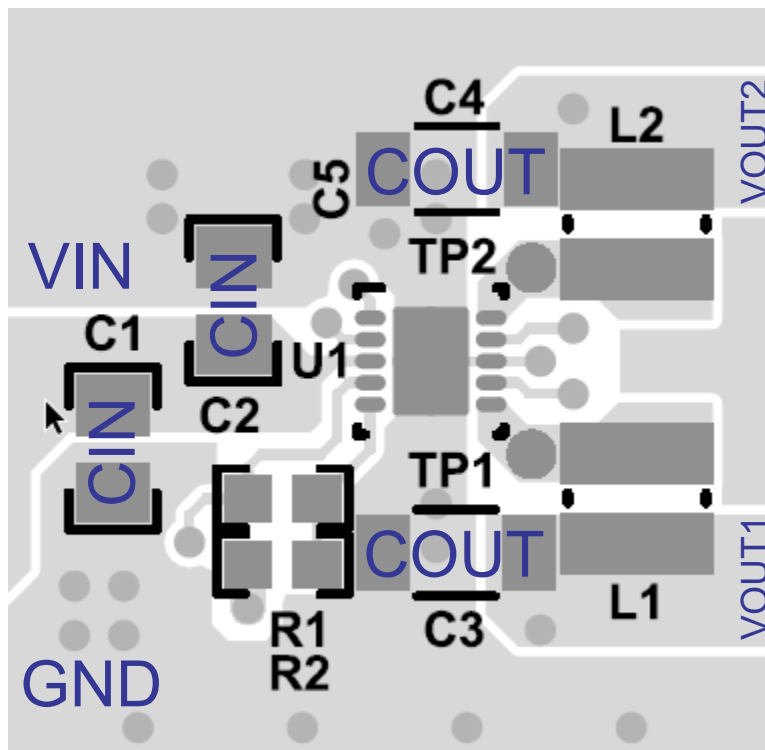
链接的内容由各个贡献者“按原样”提供。这些内容并不构成 TI 技术规范，并且不一定反映 TI 的观点；请参阅 TI 的《使用条款》。

### 12.2 接收文档更新通知

要接收文档更新通知，请导航至 [ti.com](http://ti.com) 上的器件产品文件夹。点击 [订阅更新](#) 进行注册，即可每周接收产品信息更改摘要。有关更改的详细信息，请查看任何已修订文档中包含的修订历史记录。

### 12.3 Trademarks

EasyScale™, the EasyScale™, and TI E2E™ are trademarks of Texas Instruments.  
所有商标均为其各自所有者的财产。

### 12.4 Electrostatic Discharge Caution



This integrated circuit can be damaged by ESD. Texas Instruments recommends that all integrated circuits be handled with appropriate precautions. Failure to observe proper handling and installation procedures can cause damage.

ESD damage can range from subtle performance degradation to complete device failure. Precision integrated circuits may be more susceptible to damage because very small parametric changes could cause the device not to meet its published specifications.

### 12.5 术语表

TI 术语表 本术语表列出并解释了术语、首字母缩略词和定义。

## 13 Mechanical, Packaging, and Orderable Information

The following pages include mechanical, packaging, and orderable information. This information is the most current data available for the designated devices. This data is subject to change without notice and revision of this document. For browser-based versions of this data sheet, refer to the left-hand navigation.

**PACKAGING INFORMATION**

Orderable part number	Status (1)	Material type (2)	Package   Pins	Package qty   Carrier	RoHS (3)	Lead finish/ Ball material (4)	MSL rating/ Peak reflow (5)	Op temp (°C)	Part marking (6)
<a href="#">TPS62406QDRCRQ1</a>	Active	Production	VSON (DRC)   10	3000   LARGE T&R	Yes	NIPDAU	Level-3-260C-168 HR	-40 to 125	2406Q
TPS62406QDRCRQ1.B	Active	Production	VSON (DRC)   10	3000   LARGE T&R	Yes	NIPDAU	Level-3-260C-168 HR	-40 to 125	2406Q
<a href="#">TPS62407QDRCRQ1</a>	Active	Production	VSON (DRC)   10	3000   LARGE T&R	Yes	NIPDAU	Level-3-260C-168 HR	-40 to 125	SHU
TPS62407QDRCRQ1.B	Active	Production	VSON (DRC)   10	3000   LARGE T&R	Yes	NIPDAU	Level-3-260C-168 HR	-40 to 125	SHU
<a href="#">TPS62422QDRCRQ1</a>	Active	Production	VSON (DRC)   10	3000   LARGE T&R	Yes	NIPDAUAG	Level-3-260C-168 HR	-40 to 125	2422Q
TPS62422QDRCRQ1.B	Active	Production	VSON (DRC)   10	3000   LARGE T&R	Yes	NIPDAUAG	Level-3-260C-168 HR	-40 to 125	2422Q
<a href="#">TPS62423QDRCRQ1</a>	Active	Production	VSON (DRC)   10	3000   LARGE T&R	Yes	NIPDAUAG	Level-3-260C-168 HR	-40 to 125	2423Q
TPS62423QDRCRQ1.B	Active	Production	VSON (DRC)   10	3000   LARGE T&R	Yes	NIPDAUAG	Level-3-260C-168 HR	-40 to 125	2423Q
<a href="#">TPS62424QDRCRQ1</a>	Active	Production	VSON (DRC)   10	3000   LARGE T&R	Yes	NIPDAUAG	Level-3-260C-168 HR	-40 to 125	2424Q
TPS62424QDRCRQ1.B	Active	Production	VSON (DRC)   10	3000   LARGE T&R	Yes	NIPDAUAG	Level-3-260C-168 HR	-40 to 125	2424Q

(1) **Status:** For more details on status, see our [product life cycle](#).

(2) **Material type:** When designated, preproduction parts are prototypes/experimental devices, and are not yet approved or released for full production. Testing and final process, including without limitation quality assurance, reliability performance testing, and/or process qualification, may not yet be complete, and this item is subject to further changes or possible discontinuation. If available for ordering, purchases will be subject to an additional waiver at checkout, and are intended for early internal evaluation purposes only. These items are sold without warranties of any kind.

(3) **RoHS values:** Yes, No, RoHS Exempt. See the [TI RoHS Statement](#) for additional information and value definition.

(4) **Lead finish/Ball material:** Parts may have multiple material finish options. Finish options are separated by a vertical ruled line. Lead finish/Ball material values may wrap to two lines if the finish value exceeds the maximum column width.

(5) **MSL rating/Peak reflow:** The moisture sensitivity level ratings and peak solder (reflow) temperatures. In the event that a part has multiple moisture sensitivity ratings, only the lowest level per JEDEC standards is shown. Refer to the shipping label for the actual reflow temperature that will be used to mount the part to the printed circuit board.

(6) **Part marking:** There may be an additional marking, which relates to the logo, the lot trace code information, or the environmental category of the part.

Multiple part markings will be inside parentheses. Only one part marking contained in parentheses and separated by a "~" will appear on a part. If a line is indented then it is a continuation of the previous line and the two combined represent the entire part marking for that device.

**Important Information and Disclaimer:** The information provided on this page represents TI's knowledge and belief as of the date that it is provided. TI bases its knowledge and belief on information provided by third parties, and makes no representation or warranty as to the accuracy of such information. Efforts are underway to better integrate information from third parties. TI has taken and continues to take reasonable steps to provide representative

and accurate information but may not have conducted destructive testing or chemical analysis on incoming materials and chemicals. TI and TI suppliers consider certain information to be proprietary, and thus CAS numbers and other limited information may not be available for release.

In no event shall TI's liability arising out of such information exceed the total purchase price of the TI part(s) at issue in this document sold by TI to Customer on an annual basis.

**TAPE AND REEL INFORMATION**

**QUADRANT ASSIGNMENTS FOR PIN 1 ORIENTATION IN TAPE**

\*All dimensions are nominal

Device	Package Type	Package Drawing	Pins	SPQ	Reel Diameter (mm)	Reel Width W1 (mm)	A0 (mm)	B0 (mm)	K0 (mm)	P1 (mm)	W (mm)	Pin1 Quadrant
TPS62406QDRCRQ1	VSON	DRC	10	3000	330.0	12.4	3.3	3.3	1.1	8.0	12.0	Q2
TPS62407QDRCRQ1	VSON	DRC	10	3000	330.0	12.4	3.3	3.3	1.1	8.0	12.0	Q2
TPS62422QDRCRQ1	VSON	DRC	10	3000	330.0	12.4	3.3	3.3	1.1	8.0	12.0	Q2
TPS62423QDRCRQ1	VSON	DRC	10	3000	330.0	12.4	3.3	3.3	1.1	8.0	12.0	Q2
TPS62424QDRCRQ1	VSON	DRC	10	3000	330.0	12.4	3.3	3.3	1.1	8.0	12.0	Q2

**TAPE AND REEL BOX DIMENSIONS**

\*All dimensions are nominal

Device	Package Type	Package Drawing	Pins	SPQ	Length (mm)	Width (mm)	Height (mm)
TPS62406QDRCRQ1	VSON	DRC	10	3000	346.0	346.0	33.0
TPS62407QDRCRQ1	VSON	DRC	10	3000	346.0	346.0	33.0
TPS62422QDRCRQ1	VSON	DRC	10	3000	338.0	355.0	35.0
TPS62423QDRCRQ1	VSON	DRC	10	3000	338.0	355.0	35.0
TPS62424QDRCRQ1	VSON	DRC	10	3000	338.0	355.0	35.0

## GENERIC PACKAGE VIEW

**DRC 10**

**VSON - 1 mm max height**

3 x 3, 0.5 mm pitch

PLASTIC SMALL OUTLINE - NO LEAD

This image is a representation of the package family, actual package may vary.  
Refer to the product data sheet for package details.

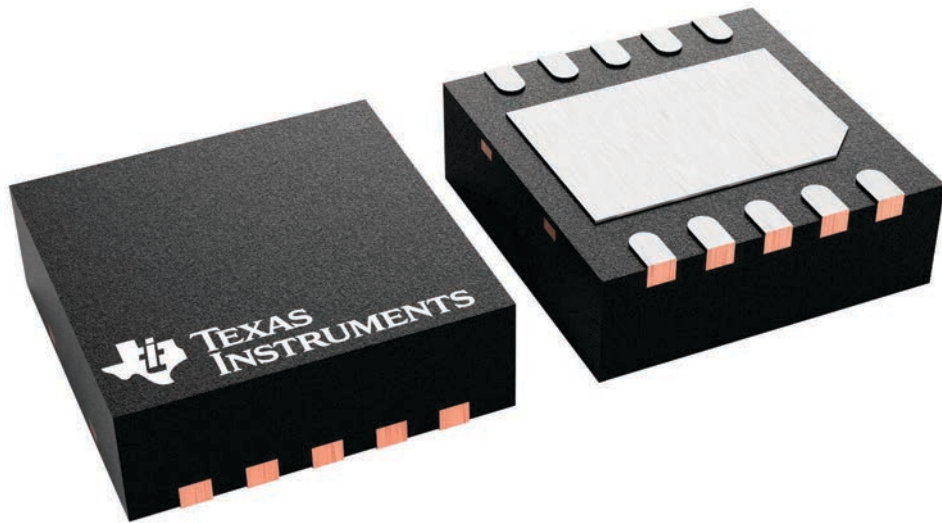

4226193/A



# EXAMPLE BOARD LAYOUT

DRC0010J

VSON - 1 mm max height

PLASTIC SMALL OUTLINE - NO LEAD

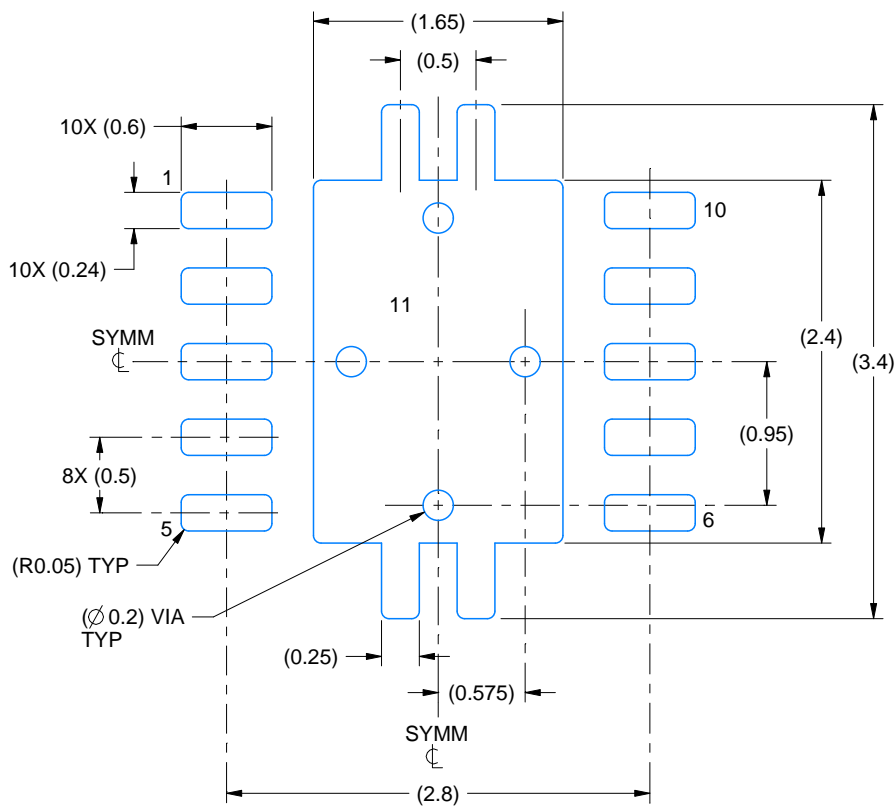

LAND PATTERN EXAMPLE  
EXPOSED METAL SHOWN  
SCALE:20X

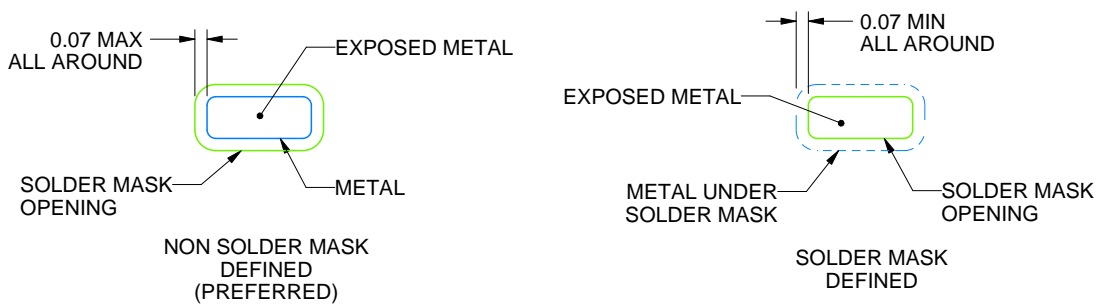

SOLDER MASK DETAILS

4218878/B 07/2018

NOTES: (continued)

4. This package is designed to be soldered to a thermal pad on the board. For more information, see Texas Instruments literature number SLUA271 ([www.ti.com/lit/sluea271](http://www.ti.com/lit/sluea271)).
5. Vias are optional depending on application, refer to device data sheet. If any vias are implemented, refer to their locations shown on this view. It is recommended that vias under paste be filled, plugged or tented.

# EXAMPLE STENCIL DESIGN

DRC0010J

VSON - 1 mm max height

PLASTIC SMALL OUTLINE - NO LEAD

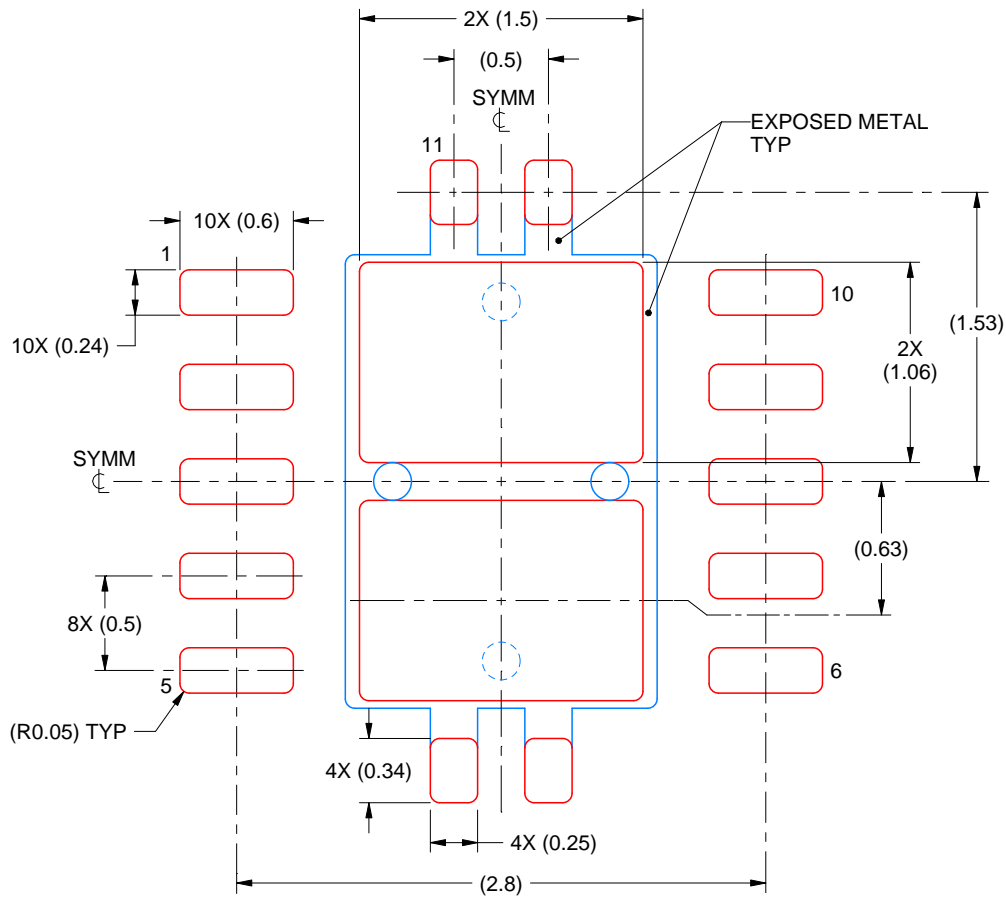

SOLDER PASTE EXAMPLE  
BASED ON 0.125 mm THICK STENCIL

EXPOSED PAD 11:  
80% PRINTED SOLDER COVERAGE BY AREA  
SCALE:25X

4218878/B 07/2018

NOTES: (continued)

6. Laser cutting apertures with trapezoidal walls and rounded corners may offer better paste release. IPC-7525 may have alternate design recommendations.

## 重要通知和免责声明

TI“按原样”提供技术和可靠性数据（包括数据表）、设计资源（包括参考设计）、应用或其他设计建议、网络工具、安全信息和其他资源，不保证没有瑕疵且不做任何明示或暗示的担保，包括但不限于对适销性、与某特定用途的适用性或不侵犯任何第三方知识产权的暗示担保。

这些资源可供使用 TI 产品进行设计的熟练开发人员使用。您将自行承担以下全部责任：(1) 针对您的应用选择合适的 TI 产品，(2) 设计、验证并测试您的应用，(3) 确保您的应用满足相应标准以及任何其他安全、安保法规或其他要求。

这些资源如有变更，恕不另行通知。TI 授权您仅可将这些资源用于研发本资源所述的 TI 产品的相关应用。严禁以其他方式对这些资源进行复制或展示。您无权使用任何其他 TI 知识产权或任何第三方知识产权。对于因您对这些资源的使用而对 TI 及其代表造成的任何索赔、损害、成本、损失和债务，您将全额赔偿，TI 对此概不负责。

TI 提供的产品受 [TI 销售条款](#)、[TI 通用质量指南](#) 或 [ti.com](#) 上其他适用条款或 TI 产品随附的其他适用条款的约束。TI 提供这些资源并不会扩展或以其他方式更改 TI 针对 TI 产品发布的适用的担保或担保免责声明。除非德州仪器 (TI) 明确将某产品指定为定制产品或客户特定产品，否则其产品均为按确定价格收入目录的标准通用器件。

TI 反对并拒绝您可能提出的任何其他或不同的条款。

版权所有 © 2026，德州仪器 (TI) 公司

最后更新日期：2025 年 10 月