

# TPS61290x 5.5V, 11A, Synchronous Boost Converter With Bypass Mode, I<sup>2</sup>C Interface, and Fast Transient Response

## 1 Features

- Wide  $V_{IN}$  range from 1.8V to 5.5V
  - Start-up input voltage: 2.2V
- Programmable average input current limit (3.5A to 11A) through I<sup>2</sup>C
- Programmable output voltage (2.35V to 5.5V) through I<sup>2</sup>C.
  - For TPS61290, default 3.4V
  - For TPS612901, if VSEL = L, default 5V; if VSEL = H, default 5.25V
- < 150mV undershoot at  $V_{IN} = 2.7V$ ,  $V_{OUT} = 3.4V$ ,  $I_{OUT} = 0A \rightarrow 3A$  (0.2A/ $\mu$ s slew rate)
- Integrated bypass MOSFET (8m $\Omega$ ), high-side MOSFET (8m $\Omega$ ), low-side MOSFET (10m $\Omega$ )
- Auto bypass mode when  $V_{IN} > V_{OUT}$
- Auto PFM operation or Forced PWM selectable at light load
- Output discharge function when EN logic is low
- True disconnection between input and output during shutdown
- Thermal shutdown and over current protection
- I<sup>2</sup>C compatible I/F up to 1Mbps
- 1.2V I/O logic control interface
- 16-ball WCSP package

## 2 Applications

- [Mobile phones](#)
- [Tablet](#)
- [Optical module](#)
- 4G, 5G mini-module data card
- Satellite communication
- RF power amplifier

## 3 Description

The TPS61290x provides a power supply design for products powered by a nickel-rich, silicon anode, Li-ion, or LiFePO<sub>4</sub> battery. The voltage range is optimized for single-cell portable applications like in smart-phones or POS terminal.

Used as a high-power pre-regulator, the device extends the battery run-time and overcomes input current and voltage limitations of the powered system. With a wide input voltage range of 1.8V to 5.5V. Program the output voltage by I<sup>2</sup>C up to 5.5V. The default output voltage of TPS61290 is 3.4V. The default output voltage of TPS612901 is 5V (VSEL = Low) and 5.25V (VSEL = High).

During operation, when the battery is in a good state of charge, the TPS61290x works in bypass mode, connecting the battery to the power supply system through the bypass FET. If the battery gets to a lower state of charge and the voltage becomes lower than the desired minimum system voltage, the device seamlessly transits into boost mode to use the full battery capacity.

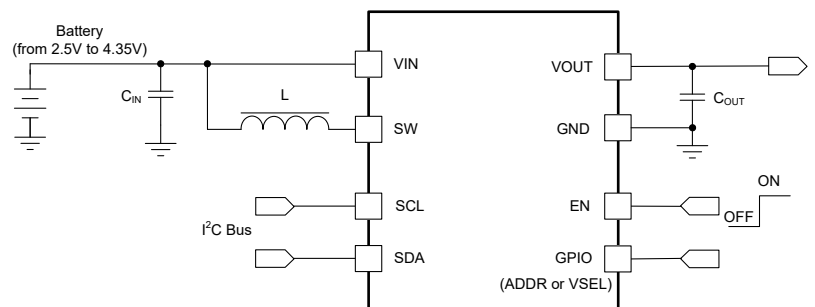
The TPS61290x offers a very small design size with a 16-ball YBG package.

### Package Information

PART NUMBER	PACKAGE <sup>(1)</sup>	PACKAGE SIZE <sup>(2)</sup>
TPS61290	YBG (DSBGA, 16)	1.577mm × 1.577mm

(1) For more information, see [Section 12](#).

(2) The package size (length × width) is a nominal value and includes pins, where applicable.



**Simplified Application Circuit**



## Table of Contents

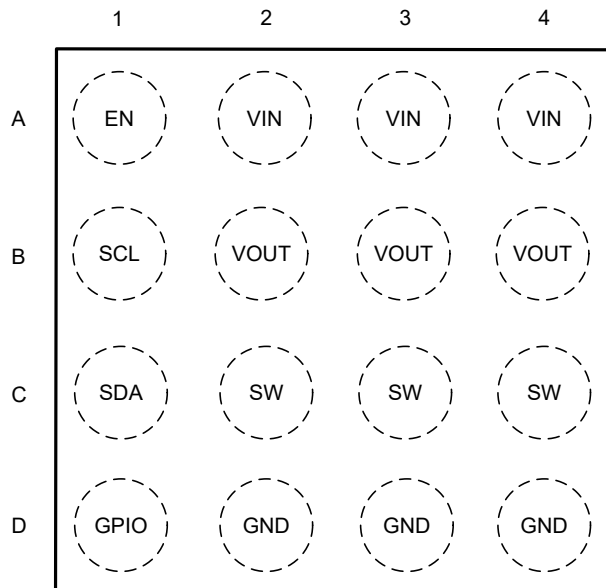
<b>1 Features</b> .....	1	8.3 VOUTFLOORSET Register .....	28
<b>2 Applications</b> .....	1	8.4 ILIMBSTSET Register .....	29
<b>3 Description</b> .....	1	8.5 VOUTROOFSET Register .....	30
<b>4 Device Comparison Table</b> .....	3	8.6 STATUS Register.....	31
<b>5 Pin Configuration and Functions</b> .....	4	8.7 ILIMPTSET Register .....	32
<b>6 Specifications</b> .....	5	8.8 BSTLOOP Register.....	33
6.1 Absolute Maximum Ratings.....	5	<b>9 Application and Implementation</b> .....	34
6.2 ESD Ratings.....	5	9.1 Application Information.....	34
6.3 Recommended Operating Conditions.....	5	9.2 Typical Application.....	34
6.4 Thermal Information.....	5	9.3 Power Supply Recommendations.....	44
6.5 Electrical Characteristics.....	6	9.4 Layout.....	44
6.6 I <sup>2</sup> C Interface Timing Requirements.....	8	<b>10 Device and Documentation Support</b> .....	47
6.7 Typical Characteristics.....	9	10.1 Device Support.....	47
<b>7 Detailed Description</b> .....	12	10.2 Receiving Notification of Documentation Updates..	47
7.1 Overview.....	12	10.3 Support Resources.....	47
7.2 Functional Block Diagram.....	13	10.4 Trademarks.....	47
7.3 Feature Description.....	14	10.5 Electrostatic Discharge Caution.....	47
7.4 Device Functional Modes.....	15	10.6 Glossary.....	47
7.5 Programming.....	21	<b>11 Revision History</b> .....	47
<b>8 Register Maps</b> .....	25	<b>12 Mechanical, Packaging, and Orderable Information</b> .....	48
8.1 DeviceID Register.....	26		
8.2 CONFIG Register.....	27		

## 4 Device Comparison Table

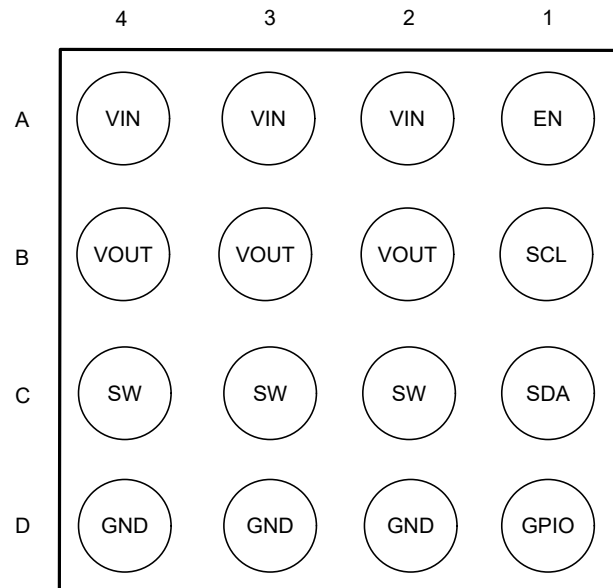
PART NUMBER	DEFAULT OUTPUT VOLTAGE	GPIO FUNCTION	DEFAULT GPIO CONFIGURATION
TPS612901YBGR	5.0V or 5.25V	VSEL	VOUTFLOORSET: (VSEL = Low, 5.0V <sub>out</sub> ) VOUTROOFSET: (VSEL = High, 5.25V <sub>out</sub> )
TPS61290YBGR <sup>(1)</sup>	3.4V	ADDR	Programmable: 75h (ADDR = L), 76h (ADDR = H), 77h (ADDR floating)

(1) Product preview (not Production Data). Contact TI factory for more information.

## 5 Pin Configuration and Functions



**Figure 5-1. TPS61290x YBG Package, 16-Pin DSBGA (Top View)**



**Figure 5-2. TPS61290x YBG Package, 16-Pin DSBGA (Bottom View)**

**Table 5-1. Pin Functions**

PIN		TYPE <sup>(1)</sup>	DESCRIPTION
NAME	NO.		
EN	A1	I	Enable logic input. Logic high voltage enables the device. Logic low voltage disables the device and turns the device into shutdown mode.
SCL	B1	I	Serial interface clock line. Terminate this pin and do not leave this pin floating.
SDA	C1	I	Serial interface address/data line. Terminate this pin and do not leave this pin floating.
GPIO	D1	I/O	Configure the pin as ADDR or VSEL function. For TPS61290, the default configuration is ADDR function. For TPS612901, the default configuration is VSEL function.
			ADDR: I <sup>2</sup> C target address selection. I <sup>2</sup> C target address is 75h when ADDR is low, I <sup>2</sup> C target address is 76h when ADDR is high, I <sup>2</sup> C target address is 77h when ADDR is floating. The address is locked when the start-up sequence is successfully completed. VSEL: DC/DC boost or bypass threshold selection pin (see also <a href="#">Section 7.3.1</a> ).
VIN	A2, A3, A4	PWR	Power supply input
VOUT	B2, B3, B4	PWR	Boost converter output
SW	C2, C3, C4	PWR	The switch pin of the converter. This pin is connected to the drain of the internal low-side power MOSFET and the source of the internal high-side power MOSFET.
GND	D2, D3, D4	PWR	Ground pin of the IC. The GND pad of output capacitor must be close to the GND pin. Layout example is shown in <a href="#">Layout Example</a> .

(1) I = input, O = output, PWR = power

## 6 Specifications

### 6.1 Absolute Maximum Ratings

over operating free-air temperature range (unless otherwise noted)<sup>(1)</sup>

			MIN	MAX	UNIT
Input voltage	V <sub>IN</sub> , SW, EN, V <sub>OUT</sub> , SCL, SDA, GPIO <sup>(2)</sup>	DC	-0.3	7	V
Input voltage	SW spike at 10ns <sup>(2)</sup>	AC	-0.7	8	V
Input voltage	SW spike at 5ns <sup>(2)</sup>	AC	-0.7	8.5	V
Input current	Continuous average current into SW <sup>(3)</sup>			6	A
Temperature	Operating junction temperature, T <sub>J</sub>		-40	150	°C
Temperature	Storage temperature, T <sub>stg</sub>		-65	150	°C

- (1) Operation outside the Absolute Maximum Ratings may cause permanent device damage. Absolute Maximum Ratings do not imply functional operation of the device at these or any other conditions beyond those listed under Recommended Operating Conditions. If used outside the Recommended Operating Conditions but within the Absolute Maximum Ratings, the device may not be fully functional, and this may affect device reliability, functionality, performance, and shorten the device lifetime.
- (2) All voltages are with respect to network ground terminal.
- (3) Lifetime is reduced when operating continuously at 6A output current and the junction temperature is higher than 85°C.

### 6.2 ESD Ratings

			VALUE	UNIT
V <sub>(ESD)</sub>	Electrostatic discharge	Human-body model (HBM), per ANSI/ESDA/JEDEC JS-001 <sup>(1)</sup>	±2000	V
		Charged-device model (CDM), per ANSI/ESDA/JEDEC JS-002 <sup>(2)</sup>	±500	

- (1) JEDEC document JEP155 states that 500V HBM allows safe manufacturing with a standard ESD control process. Manufacturing with less than 500V HBM is possible with the necessary precautions. Pins listed as ±2000 V may actually have higher performance.
- (2) JEDEC document JEP157 states that 250V CDM allows safe manufacturing with a standard ESD control process. Manufacturing with less than 250V CDM is possible with the necessary precautions. Pins listed as ±500 V may actually have higher performance.

### 6.3 Recommended Operating Conditions

		MIN	NOM	MAX	UNIT
V <sub>IN</sub>	Input voltage range	1.8		5.2	V
V <sub>OUT</sub>	Output voltage setting range	2.35		5.5	V
L	Effective inductance range, V <sub>OUT</sub> ≤ 4.5V	70	100	130	nH
	Effective inductance range, V <sub>OUT</sub> > 4.5V	150	220	330	nH
C <sub>in</sub>	Effective input capacitance range		5		μF
C <sub>O</sub>	Effective output capacitance range, I <sub>out</sub> ≤ 4A	15	20		μF
	Effective output capacitance range, 4A < I <sub>out</sub> ≤ 6A	20			μF
T <sub>J</sub>	Operating junction temperature	-40		125	°C

### 6.4 Thermal Information

THERMAL METRIC <sup>(1)</sup>		TPS61290x	TPS61290x	UNIT
		YBG (16 PINS)	YBG (16 PINS)	
		Standard	EVM <sup>(2)</sup>	
R <sub>θJA</sub>	Junction-to-ambient thermal resistance	78	40.5	°C/W
R <sub>θJC</sub>	Junction-to-case thermal resistance	0.6	N/A	°C/W
R <sub>θJB</sub>	Junction-to-board thermal resistance	13	N/A	°C/W
Ψ <sub>JT</sub>	Junction-to-top characterization parameter	2.4	0.1	°C/W
Ψ <sub>JB</sub>	Junction-to-board characterization parameter	13	16.0	°C/W

- (1) For more information about traditional and new thermal metrics, see the [Semiconductor and IC Package Thermal Metrics](#) application note.

(2) Measured on TPS61290EVM-075, 4-layer, 2oz copper 92.2mm × 59.2mm PCB.

## 6.5 Electrical Characteristics

$T_J = -40^\circ\text{C}$  to  $125^\circ\text{C}$ ,  $V_{IN} = 1.8\text{V}$  to  $5.5\text{V}$ ,  $V_{OUT} = 3.4\text{V}$  (or  $V_{IN}$ , whichever is higher),  $EN = 1.2\text{V}$ ,  $GPIO = 1.2\text{V}$ . Typical values are at  $V_{IN} = 3.2\text{V}$ ,  $V_{OUT} = 3.4\text{V}$ ,  $EN = 1.2\text{V}$ ,  $T_J = 25^\circ\text{C}$ , unless otherwise noted.

PARAMETER		TEST CONDITIONS	MIN	TYP	MAX	UNIT
<b>POWER SUPPLY</b>						
$V_{IN}$	Input voltage range		1.8		5.5	V
$V_{UVLO}$	Undervoltage lockout threshold	Rising		2.1	2.2	V
$V_{UVLO}$	Undervoltage lockout threshold	Falling		1.7	1.8	V
		Hysteresis		0.4		V
$I_Q$	Operating quiescent current into $V_{IN}$	DC/DC boost mode. Device not switching $EN = V_{IN}$ , $ENABLE\_bit = 01$ $-40^\circ\text{C} \leq T_J \leq 85^\circ\text{C}$		40	55	$\mu\text{A}$
	Operating quiescent current into $V_{OUT}$	DC/DC boost mode. Device not switching $EN = V_{IN}$ , $ENABLE\_bit = 01$ $2.35\text{V} \leq V_{OUT} \leq 5.5\text{V}$ $-40^\circ\text{C} \leq T_J \leq 85^\circ\text{C}$		12	21	$\mu\text{A}$
	Operating quiescent current in auto bypass mode	True bypass mode (auto) $EN = V_{IN}$ , $ENABLE\_bit = 01$ $-40^\circ\text{C} \leq T_J \leq 85^\circ\text{C}$		30	46	$\mu\text{A}$
	Operating quiescent current in forced bypass mode	True bypass mode (forced) $EN = V_{IN}$ , $ENABLE\_bit = 10$ $-40^\circ\text{C} \leq T_J \leq 85^\circ\text{C}$		27	45	$\mu\text{A}$
$I_{SD}$	Shutdown current	Shutdown mode $EN = GND$ , $V_{OUT} = GND$ $T_J = 25^\circ\text{C}$		0.55	2	$\mu\text{A}$
	Shutdown current	Shutdown mode $EN = GND$ , $V_{OUT} = GND$ $-40^\circ\text{C} \leq T_J \leq 85^\circ\text{C}$		0.55	11	$\mu\text{A}$
	Shutdown current	Shutdown mode $EN = GND$ , $V_{OUT} = GND$ $T_J = 25^\circ\text{C}$		16	23	$\mu\text{A}$
	Shutdown current	Shutdown mode, but $I^2C$ block is active. $EN = V_{IN}$ , $ENABLE\_bit = 11$ $-40^\circ\text{C} \leq T_J \leq 85^\circ\text{C}$		16	29	$\mu\text{A}$
<b>EN, SDA, SCL, GPIO</b>						
$V_{IL}$	Low-level input voltage		0.33			V
$V_{IH}$	High-level input voltage			0.82		V
$V_{OL}$	Low-level output voltage (SDA)	$I_{OL} = 8\text{mA}$			0.36	V
$R_{PD}$	EN pull-down resistance	Applied voltage $< 0.4\text{V}$		800		$\text{k}\Omega$
$I_{kg}$	Input leakage current	$-40^\circ\text{C} \leq T_J \leq 85^\circ\text{C}$			0.1	$\mu\text{A}$
<b>OUTPUT</b>						
$V_{OUT}$	Output voltage setting range		2.35		5.5	V
$V_{OUT\_PWM}$	DC voltage accuracy	$2.2\text{V} \leq V_{IN} \leq V_{OUT\_TAR} - 150\text{mV}$ PWM/PFM operation.	-1.5		1.5	%
$V_{OUT\_BP\_ENTER}$	Enter bypass mode threshold	$MODE\_CTRL = 00$ , auto PFM		$V_{OUT\_P\_WM} \times (1+0.5\%)$		V
$V_{OUT\_BP\_ENTER}$	Enter bypass mode threshold	$MODE\_CTRL = 10$ , FPWM		$V_{OUT\_P\_WM} \times (1+2\%)$		V

## 6.5 Electrical Characteristics (continued)

$T_J = -40^\circ\text{C}$  to  $125^\circ\text{C}$ ,  $V_{IN} = 1.8\text{V}$  to  $5.5\text{V}$ ,  $V_{OUT} = 3.4\text{V}$  (or  $V_{IN}$ , whichever is higher),  $EN = 1.2\text{V}$ ,  $\text{GPIO} = 1.2\text{V}$ . Typical values are at  $V_{IN} = 3.2\text{V}$ ,  $V_{OUT} = 3.4\text{V}$ ,  $EN = 1.2\text{V}$ ,  $T_J = 25^\circ\text{C}$ , unless otherwise noted.

PARAMETER		TEST CONDITIONS	MIN	TYP	MAX	UNIT
$V_{OUT\_BP\_EXT}$	Exit bypass mode threshold			$V_{OUT\_P\_WM} \times (1-3\%)$		V
$V_{OVP}$	Output overvoltage protection threshold	$V_{OUT}$ rising		5.58		V
$R_{DIS\_OUT}$	Output equivalent discharge impedance			90		$\Omega$
<b>POWER SWITCH</b>						
$R_{DS(on)}$	Low-side switch MOSFET on resistance	$V_{OUT} = 5\text{V}$		8	13.5	m $\Omega$
	High-side rectifier MOSFET on resistance	$V_{OUT} = 5\text{V}$		8	13.5	m $\Omega$
	Low-side switch MOSFET on resistance	$V_{OUT} = 3.4\text{V}$		10	15	m $\Omega$
	High-side rectifier MOSFET on resistance	$V_{OUT} = 3.4\text{V}$		10	15	m $\Omega$
	Bypass MOSFET on resistance	$V_{OUT} = 2.35\text{V}$ to $5.5\text{V}$		10	15	m $\Omega$
$I_{LIM\_SW}$	Average Inductor current limit	$ILIM\_BOOST = 1100$ (default), $1.8\text{V} \leq V_{IN} \leq 5.5\text{V}$	9.5	11	13	A
	Average Inductor current limit adjustable range via I <sup>2</sup> C	Typical value, $1.8\text{V} \leq V_{IN} \leq 5.5\text{V}$	3.5		11	A
$ILIM\_REVERSE$	Reverse current limit (FPWM operation)	$MODE\_CTRL = 10$		-2		A
$I_{LIM\_BP}$	Bypass mode current limit (Forced)	$ENABLE\_bit = 10$ , $ILIM\_FPT = 010$ (default)	6	8	10.5	A
	Bypass mode current limit (Auto)	$ENABLE\_bit = 01$ , $ILIM\_APT = 010$ (default)	6	8	10.5	A
$I_{lkg}$	Low-side switch MOSFET leakage current	$EN = GND$ , $-40^\circ\text{C} \leq T_J \leq 85^\circ\text{C}$		0.1	5	$\mu\text{A}$
	High-side switch MOSFET leakage current	$EN = GND$ , $-40^\circ\text{C} \leq T_J \leq 85^\circ\text{C}$		0.1	5	$\mu\text{A}$
	Bypass MOSFET leakage current	$EN = GND$ , $-40^\circ\text{C} \leq T_J \leq 85^\circ\text{C}$		0.6	5	$\mu\text{A}$
<b>OSCILLATOR</b>						
$T_{ON\_MIN}$	Minimum On time	PWM mode		80		ns
$F_{sw\_min\_fpwm}$	Minimum switching frequency in FPWM	$MODE\_CTRL = 10$	375	440		kHz
$F_{DITHER}$	Spread Spectrum dithering frequency	$V_{IN} = 3.2\text{V}$ , $V_{OUT} = 3.4\text{V}$ , $MODE\_CTRL = 10$ , $SSFM = 1$		$\pm 8\%$		$F_{sw}$
<b>THERMAL SHUTDOWN, HOT DIE DETECTOR</b>						
$T_{SD}$	Thermal shutdown <sup>(1)</sup>	$T_J$ rising		165		$^\circ\text{C}$
$T_{SD\_HYS}$	Thermal shutdown hysteresis <sup>(1)</sup>			20		
<b>TIMING</b>						
	Soft start-up time <sup>(1)</sup>	Internal SS ramp time		400		$\mu\text{s}$
	Hiccup on time	$HICCUP\_MODE$ bit = 1		1		ms
	Hiccup off time	$HICCUP\_MODE$ bit = 1		19		ms

(1) Verified by characterization. Not tested in production.

## 6.6 I<sup>2</sup>C Interface Timing Requirements

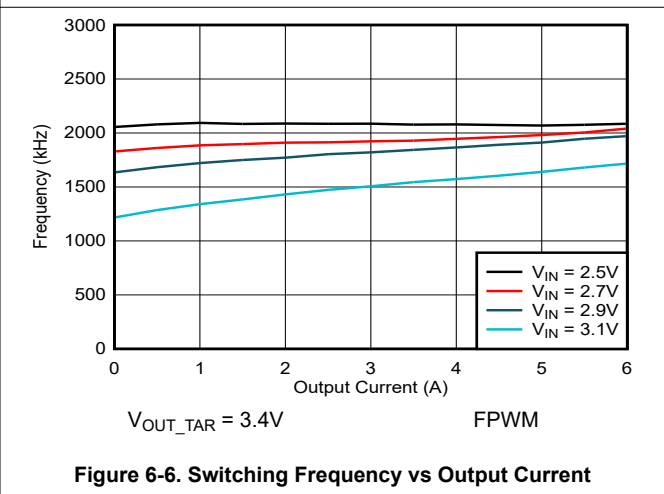
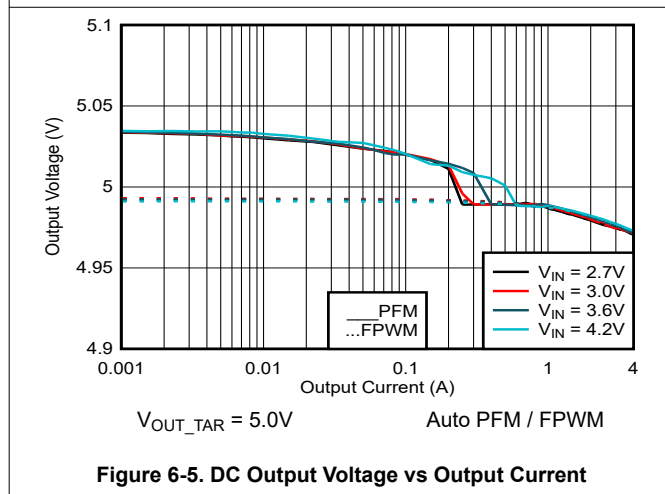
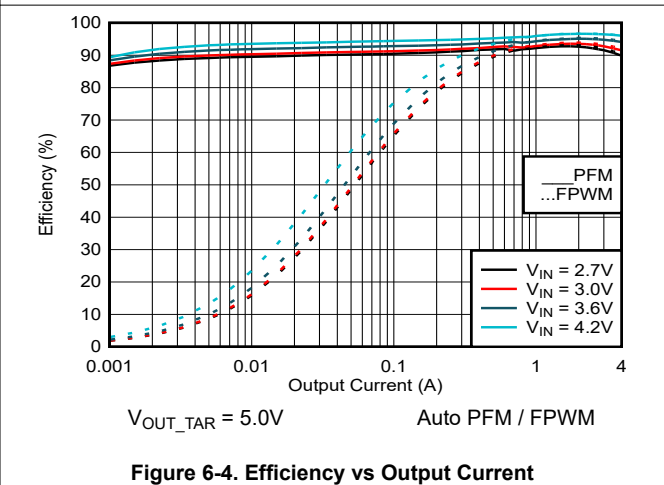
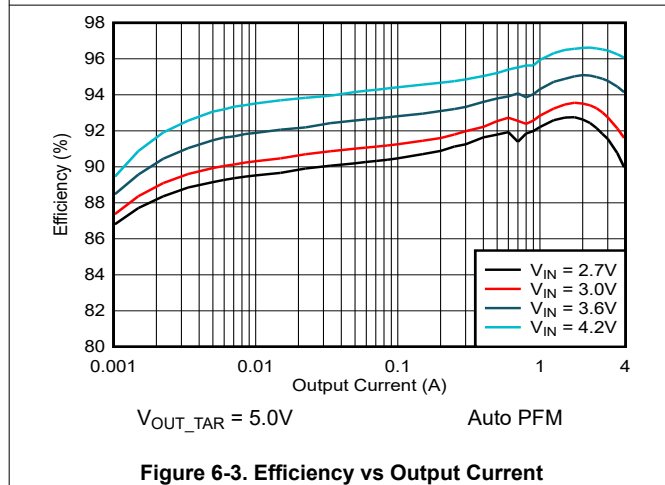
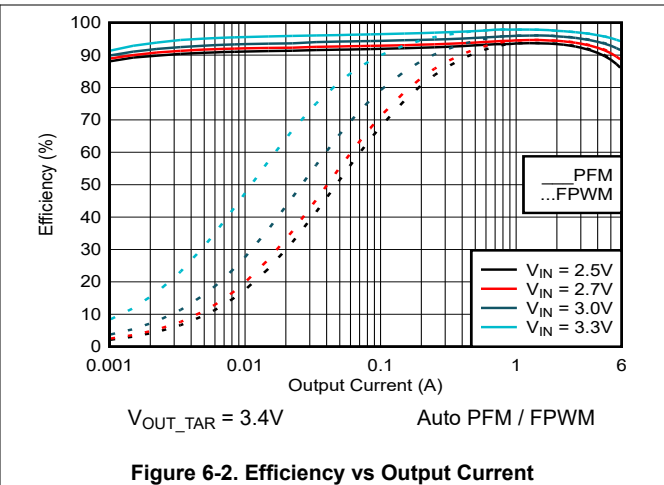
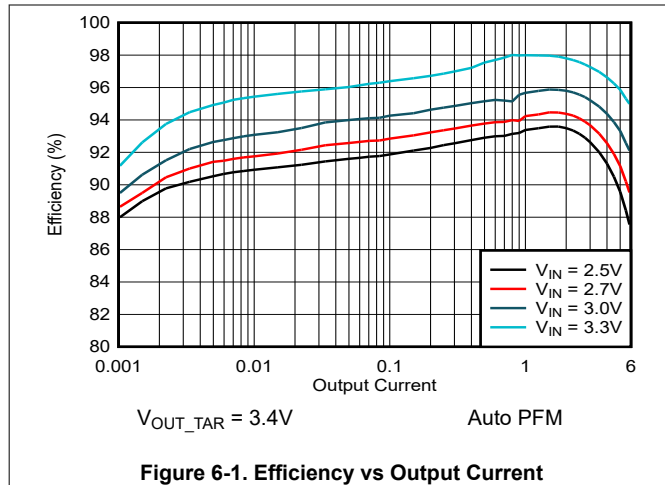
Over operating junction temperature range and recommended supply voltage range (unless otherwise noted)<sup>(1)</sup>

PARAMETER		TEST CONDITIONS	MIN	MAX	UNIT
f <sub>(SCL)</sub>	SCL Clock Frequency	Standard mode		100	kHz
f <sub>(SCL)</sub>	SCL Clock Frequency	Fast mode		400	kHz
f <sub>(SCL)</sub>	SCL Clock Frequency	Fast mode plus		1	MHz
t <sub>BUF</sub>	Bus Free Time Between a STOP and START Condition	Fast mode plus	0.5		μs
t <sub>HD</sub> , t <sub>STA</sub>	Hold Time (Repeated) START Condition		260		ns
t <sub>LOW</sub>	LOW Period of the SCL Clock		0.5		μs
t <sub>HIGH</sub>	HIGH Period of the SCL Clock		260		ns
t <sub>SU</sub> , t <sub>STA</sub>	Setup Time for a Repeated START Condition		260		ns
t <sub>SU</sub> , t <sub>DAT</sub>	Data Setup Time		50		ns
t <sub>HD</sub> , t <sub>DAT</sub>	Data Hold Time		0		μs
t <sub>RCL</sub>	Rise Time of SCL Signal			120	ns
t <sub>RCL1</sub>	Rise Time of SCL Signal After a Repeated START Condition and After an Acknowledge BIT			120	ns
t <sub>FCL</sub>	Fall Time of SCL Signal			120	ns
t <sub>RDA</sub>	Rise Time of SDA Signal			120	ns
t <sub>FDA</sub>	Fall Time of SDA Signal			120	ns
t <sub>SU</sub> , t <sub>STO</sub>	Setup Time of STOP Condition		260		ns
C <sub>B</sub>	Capacitive Load for SDA and SCL			200	pF

(1) Specified by design. Not tested in production.

## 6.7 Typical Characteristics

Typical condition  $V_{IN} = 2.5V$  to  $4.5V$ ,  $V_{OUT\_TAR} = 3.4V$  and  $5.0V$ ,  $T_J = 25^\circ C$ , unless otherwise noted



## 6.7 Typical Characteristics (continued)

Typical condition  $V_{IN} = 2.5V$  to  $4.5V$ ,  $V_{OUT\_TAR} = 3.4V$  and  $5.0V$ ,  $T_J = 25^\circ C$ , unless otherwise noted

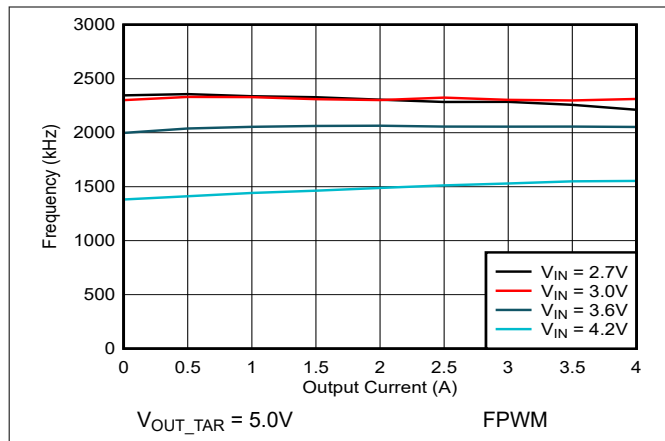


Figure 6-7. Switching Frequency vs Output Current

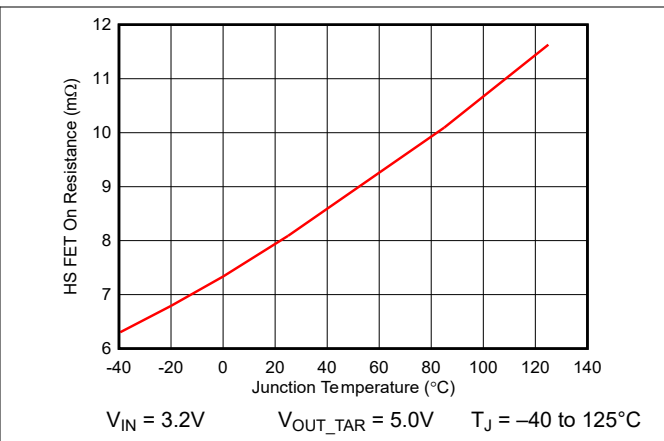


Figure 6-8. High side  $R_{ds(on)}$  vs Junction Temperature

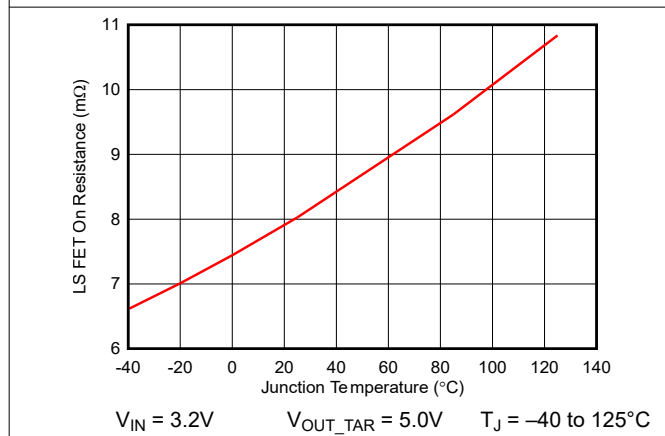


Figure 6-9. Low side  $R_{ds(on)}$  vs Junction Temperature

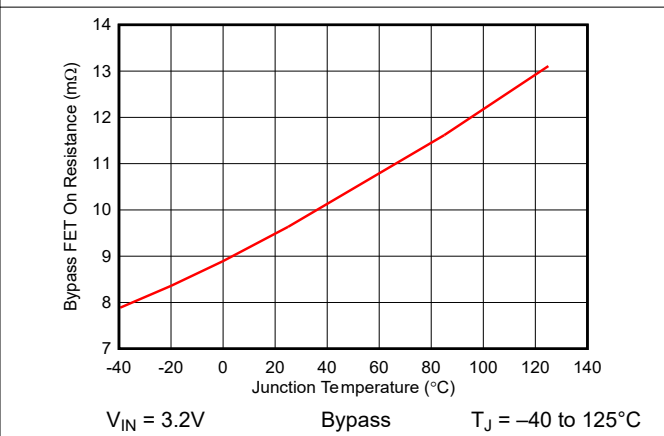


Figure 6-10. Bypass FET  $R_{ds(on)}$  vs Junction Temperature

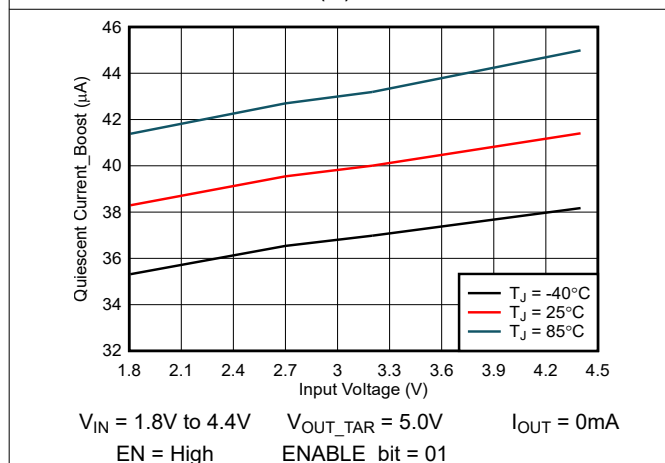


Figure 6-11. Quiescent Current at Boost Mode vs Input Voltage

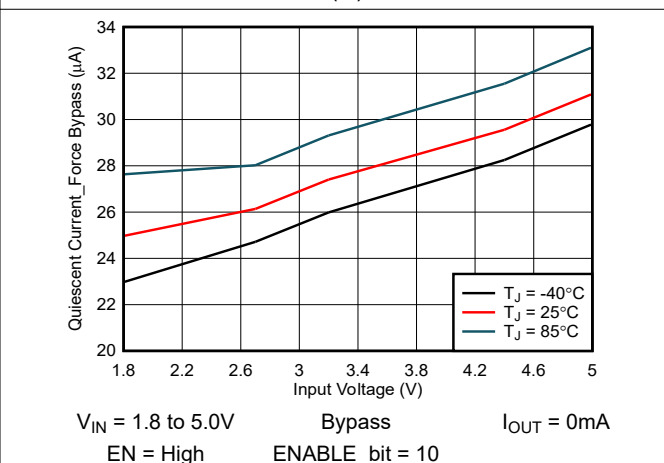
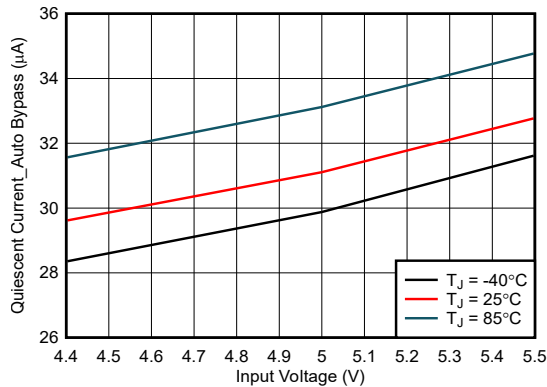


Figure 6-12. Quiescent Current at Forced Bypass Mode vs Input Voltage

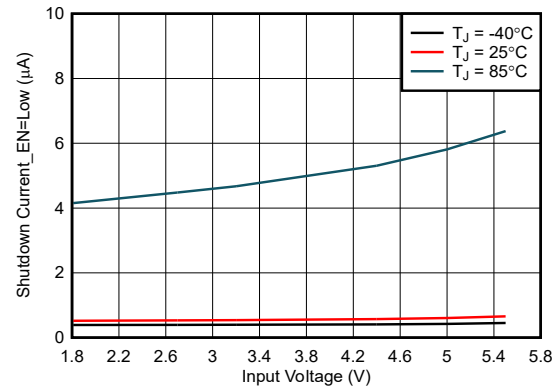
## 6.7 Typical Characteristics (continued)

Typical condition  $V_{IN} = 2.5V$  to  $4.5V$ ,  $V_{OUT\_TAR} = 3.4V$  and  $5.0V$ ,  $T_J = 25^\circ C$ , unless otherwise noted



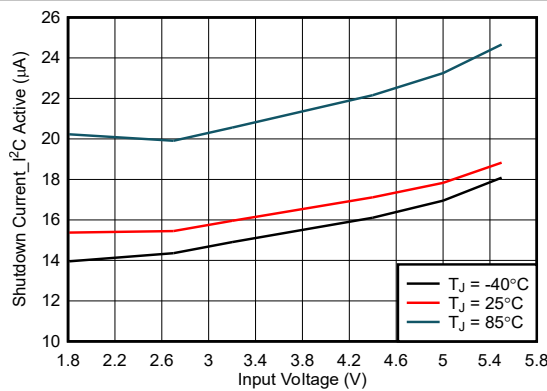
$V_{IN} = 4.4$  to  $5.5V$  Bypass  $I_{OUT} = 0mA$   
EN = High ENABLE\_bit = 01  $V_{OUT\_TAR} = 3.4V$

Figure 6-13. Quiescent Current at Auto Bypass Mode vs Input Voltage



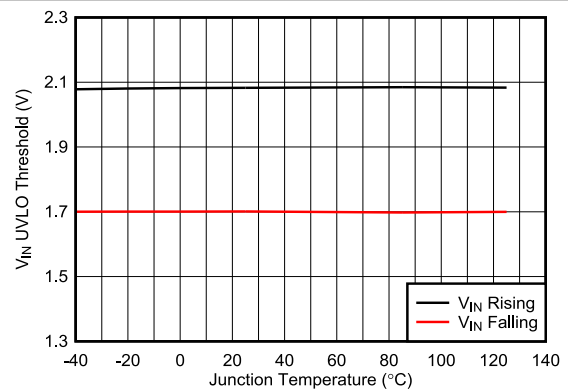
$V_{IN} = 1.8$  to  $5.5V$   $V_{OUT} = GND$  EN = Low

Figure 6-14. Shutdown Current at EN = Low vs Input Voltage



$V_{IN} = 1.8$  to  $5.5V$  ENABLE\_bit = 11 EN = High

Figure 6-15. Shutdown Current with Active I<sup>2</sup>C Block vs Input Voltage



$V_{OUT\_TAR} = 5.0V$   $T_J = -40$  to  $125^\circ C$

Figure 6-16.  $V_{IN}$  UVLO Threshold Rising/Falling vs Junction Temperature

## 7 Detailed Description

### 7.1 Overview

The TPS61290x is a high-efficiency, synchronous boost converter featuring bypass mode optimized to provide low-noise voltage supply for RF power amplifiers (PAs) in mobile phones. The device can also be used to pre-regulate voltage for supplying subsystems like eMMC memory, audio codec, LCD bias, antenna switches, RF engine PMIC and so on. The TPS61290x has a low side 8mΩ power switch, a 8mΩ high side rectifier switch, and a 10mΩ bypass switch to make sure the system operates at a high efficiency under a wide input voltage range.

The capability of the TPS61290x to step-up the voltage as well as to bypass the input battery voltage when the level is high enough allow systems to operate at maximum performance over a wide range of battery voltages, thereby extending the battery life. The device also addresses brownouts caused by the peak currents drawn by the APU and GPU which causes the battery rail to drop momentarily. Using the TPS61290x device as a pre-regulator eliminates system brownout condition while maintaining a stable supply rail for critical sub-system to function properly.

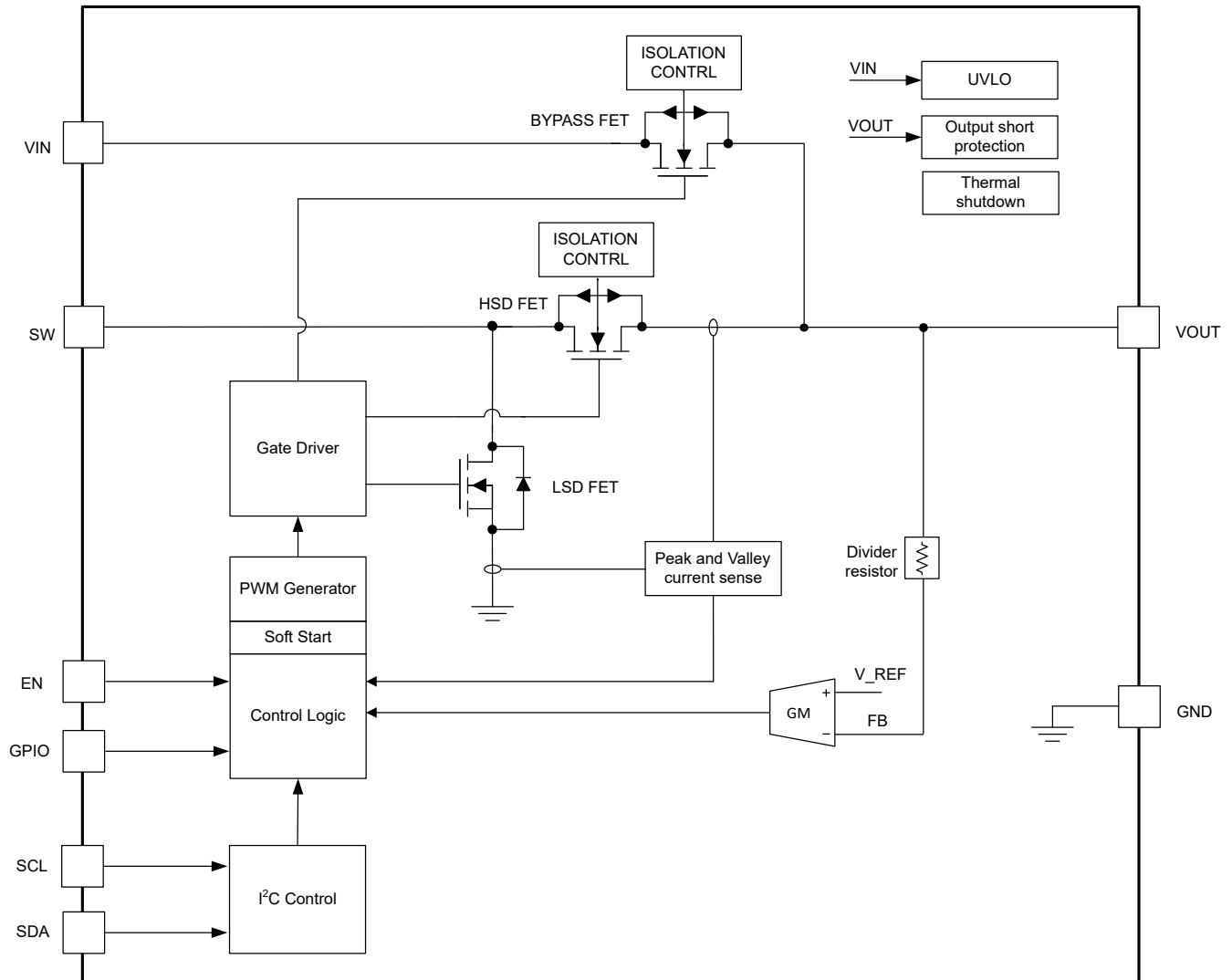
The TPS61290x uses a hysteretic control scheme. At light load, the TPS61290x converter operates in power save mode with pulse frequency modulation (auto PFM), or forced PWM, which is programmable by I<sup>2</sup>C.

In general, a DC/DC step-up converter only operates in "true" boost mode; that is, the output "boosted" by a certain amount above the input voltage. The TPS61290x device operates differently as the device smoothly transitions in and out of zero duty cycle operation. Depending upon the input voltage, output voltage threshold and load current, the integrated bypass switch automatically transitions the converter into so called true bypass mode to maintain low-dropout and high-efficiency. The device exits true bypass mode (0% duty cycle operation) if the total dropout resistance in true bypass mode is insufficient to maintain the output voltage at the nominal level.

The TPS612901 can dynamically adjust the output voltage by VSEL function. Use this feature to either raise the output voltage in anticipation of a positive load transient or to dynamically change the PA supply voltage depending on the mode of operation and transmitting power.

The TPS61290x integrates an I<sup>2</sup>C compatible interface allowing transfers up to 1Mbps. Use this communication interface to set the output voltage threshold at which the converter transitions between boost and bypass mode, for reprogramming the mode of operation (auto PFM or forced PWM), for settings the average current limit or resetting the output voltage for instance. The I<sup>2</sup>C compatible interface address can be adjusted by ADDR function (TPS61290). Use this ADDR function feature when there are one more units per one I<sup>2</sup>C bus.

## 7.2 Functional Block Diagram



## 7.3 Feature Description

### 7.3.1 Output Voltage Setting

To maintain a certain minimum output voltage under heavy load transients, dynamically increase the output voltage set point by I<sup>2</sup>C register. The functionality also helps to mitigate undershoot during severe line transients, while minimizing the output voltage during more benign operating conditions to save power.

For TPS61290x, the GPIO is configured as ADDR function, only set the output voltage by VOUTFLOORSET (default 3.4V). For TPS612901, the GPIO is configured as VSEL function, set the VSEL = low to let V<sub>OUT\_TAR</sub> = 5.0V (default), set the VSEL = high to let V<sub>OUT\_TAR</sub> = 5.25V (default).

### 7.3.2 Switching Frequency and Spread Spectrum Function

The TPS61290x uses a hysteretic control scheme, and TPS61290x maintains a constant inductor ripple current in the range of 3.0A. Therefore, the frequency is not fixed and determined by the operation condition. The frequency is approximately 2MHz, when the input is 2.7V, output is 3.4V, inductor is 100nH.

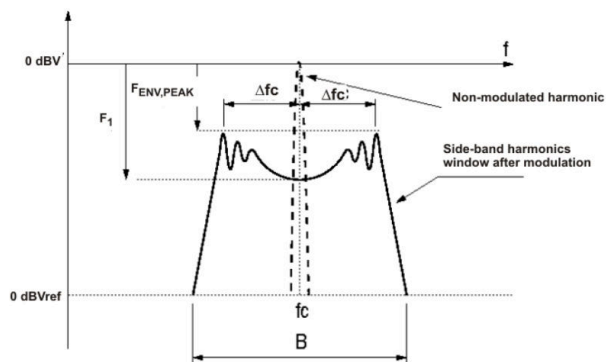
In auto PFM operation, the minimum switching frequency is not limited, the switching frequency is approximately 20Hz (or even lower) with open load.

In forced PWM operation, minimum switching frequency is limited to approximately 375kHz. With this unique feature, the TPS61290x avoids the low frequency switching and prevents the application against the low frequency noise sensitive range.

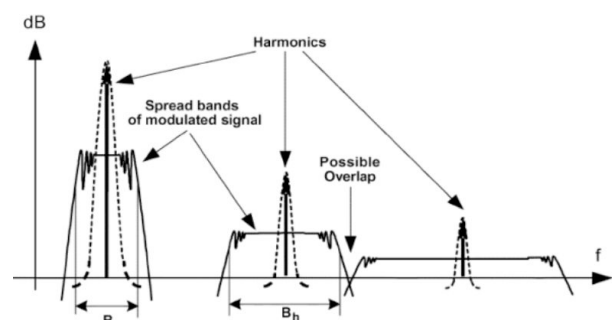
Switching regulators are particularly troublesome in applications where electromagnetic interference (EMI) is a concern. Switching regulators operate on a cycle-by-cycle basis to transfer power to an output. In most cases, the frequency of operation is either fixed or regulated, based on the output load. This method of conversion creates large components of noise at the frequency of operation (fundamental) and multiples of the operating frequency (harmonics).

The TPS61290x provides a spread spectrum feature. The goal is to spread out the emitted RF energy over a larger frequency range so that the resulting EMI is similar to white noise. The result is a spectrum that is continuous and lower in peak amplitude, making complying with electromagnetic interference (EMI) standards and with the power supply ripple requirements in cellular and non-cellular wireless applications easier. Radio receivers are typically susceptible to narrowband noise that is focused on specific frequencies.

The spread spectrum architecture varies the switching frequency by ca. ±8% of the nominal switching frequency thereby significantly reducing the peak radiated and conducting noise on both the input and output supplies. The frequency dithering scheme is modulated with a triangle profile and a modulation frequency  $f_m$ .



**Figure 7-1. Spectrum of a Frequency Modulated Sin - Wave With Sinusoidal Variation in Time**



**Figure 7-2. Spread Bands of Harmonics in Modulated Square Signals <sup>1</sup>**

<sup>1</sup> Spectrum illustrations and formulae ( Figure 7-1 and Figure 7-2 ) copyright IEEE TRANSACTIONS ON ELECTROMAGNETIC COMPATIBILITY, VOL. 47, NO.3, AUGUST 2005.

The above figures show that after modulation the sideband harmonic is attenuated compared to the non-modulated harmonic, and the harmonic energy is spread into a certain frequency band. The higher the modulation index ( $mf$ ) the larger the attenuation.

$$m_f = \frac{\delta \times f_c}{f_m} \quad (1)$$

where

- $f_c$  is the carrier frequency (switching frequency)
- $f_m$  is the modulating frequency (approximately  $0.5\% \times f_c$ )
- $\delta$  is the modulation ratio (approximately 8%)

$$\delta = \frac{\Delta f_c}{f_c} \quad (2)$$

The maximum switching frequency  $f_c$  is limited by the process and finally the parameter modulation ratio ( $\delta$ ), together with  $f_m$ , which is the side-band harmonics bandwidth around the carrier frequency  $f_c$ . The bandwidth of a frequency modulated waveform is approximately given by the Carson's rule and can be summarized as:

$$B = 2 \times f_m \times (1 + m_f) = 2 \times (\Delta f_c + f_m) \quad (3)$$

$f_m < \text{RBW}$ : The receiver is not able to distinguish individual side-band harmonics, so, several harmonics are added in the input filter and the measured value is higher than expected in theoretical calculations.

$f_m > \text{RBW}$ : The receiver is able to properly measure each individual side-band harmonic separately, so the measurements match with the theoretical calculations.

## 7.4 Device Functional Modes

### 7.4.1 Enable and Start-Up

The TPS61290x automatically powers-up after an input voltage greater than 2.2V and less than 5.5V is applied. After start-up, the input voltage can be reduced to 1.8V. The device has an internal soft-start circuit that limits the inrush current during start-up.

The first phase in the start-up procedure is to bias the output node close to the input level (also called down mode pre-charge phase). In this operation mode, when  $V_{IN}$  exceeds 2.8V, the TPS61290x has three operating conditions:

- When output voltage is lower than 0.8V, the inductor average current is limited to approximately 0.75A.
- When the output voltage is higher than 0.8V but lower than the input voltage minus 2.0V, the inductor average current limit is increased to approx 1.5A.
- When the output voltage is higher than the input voltage minus 2.0V but lower than the input voltage, the average inductor current limit is increased to the half of boost current limit (approximately 5.5A).

When  $V_{IN}$  does not exceed 2.8V, the TPS61290x only has two operating conditions during the down mode pre-charge phase. [Table 7-1](#) show more details for this operation.

The second phase in start-up procedure is boost switching phase. In this operation mode, the output voltage is higher than input voltage, and the average inductor current limit is increased to boost current limit (approx 11A).

Using this method the loading capability during start-up is improved and this is helpful to reduce the input current overshoot during start-up. [Table 7-1](#) and [Table 7-2](#) shows the relationship between average inductor current limit and output voltage in start-up phase.

**Table 7-1. Average Inductor Current Limit Setting During Start-Up ( $V_{IN} \leq 2.8V$ )**

PHASE	AVERAGE INDUCTOR CURRENT LIMIT	OUTPUT VOLTAGE
Down mode pre-charge phase	0.75A (typical)	$V_{OUT} \leq 0.8V$
	5.5A (typical)	$V_{IN} - 2.0V < V_{OUT} \leq V_{IN}$
Boost switching phase	11A (typical)	$V_{IN} < V_{OUT}$

**Table 7-2. Average Inductor Current Limit Setting During Start-Up ( $V_{IN} > 2.8V$ )**

PHASE	INDUCTOR AVERAGE CURRENT LIMIT	OUTPUT VOLTAGE
Down mode pre-charge phase	0.75A (typical)	$V_{OUT} \leq 0.8V$
	1.5A (typical)	$0.8V < V_{OUT} \leq V_{IN} - 2.0V$
	5.5A (typical)	$V_{IN} - 2.0V < V_{OUT} \leq V_{IN}$
Boost switching phase	11A (typical)	$V_{IN} < V_{OUT}$

In down mode pre-charge phase, if the output voltage does not reach the input voltage after 1ms, the device remains in a waiting state for 19ms before attempting to restart again.

The TPS61290x is able to start up with 2.2V UVLO rising threshold with larger than 10Ω load. However, if the load during start-up is so heavy or the output capacitance is so large that the TPS61290x fails to charge the output voltage to target value, the TPS61290x does not start up successfully until the input voltage is increased or the load current is reduced. The total start-up time depends on input voltage, output capacitance and load current.

#### 7.4.2 Operation Mode Setting

The TPS61290x device can be configured (through Section 7.6.5) to select the operating mode of the device.

When the EN pin is set to logic high, ENABLE bit (CONFIG[5:6]) = 01 (default value), the device enters normal mode (that is, automatic boost/bypass mode) and enables the output voltage to remain above a pre-defined target voltage.

When the EN pin is set to logic high, ENABLE bit (CONFIG[5:6]) = 10, the device enters forced bypass mode. In this mode, the synchronous rectifier is current limited to ca. 8A (programmable through I<sup>2</sup>C) allowing an external load (for example audio amplifier) to be powered with a restricted supply. The output voltage is slightly reduced due to voltage drop across the bypass MOSFET. The device consumes only a standby current of 23μA (typical).

When the EN pin is set to logic high, and ENABLE bit (CONFIG[5:6]) = 11 forces the device in shutdown mode, but I<sup>2</sup>C block works, with a standby current of typically 16μA. In this mode, true load disconnect between the battery and load prevents current flow from VIN to VOUT, as well as reverse current flow from VOUT to VIN.

When the EN pin is set to logic low forces the device in shutdown mode (regardless of what ENABLE bit is), with a shutdown current of typically 0.8μA. In this mode, true load disconnect between the battery and load prevents current flow from VIN to VOUT, as well as reverse current flow from VOUT to VIN.

**Table 7-3. Mode of Operation**

EN PIN	ENABLE BIT	OPERATION MODE
Low	xx	Shutdown mode. True load disconnection and no $V_{OUT}$ . The device shutdown current is approximately 0.8μA typical.
High	11	I <sup>2</sup> C shutdown mode. Power stage is turned off and no $V_{OUT}$ , but I <sup>2</sup> C is active. True load disconnection. The device standby current in this mode is approximately 16μA typical.
High	10	Forced bypass mode. $V_{OUT}$ follows $V_{IN}$ . The device standby current is approximately 23μA typical.
High	00/01 (default 01)	Automatic boost/bypass mode. In boost mode, $V_{OUT} = V_{OUT\_TAR}$ (default 3.4V). In bypass mode, $V_{OUT}$ follows $V_{IN}$ .

### 7.4.3 Bypass Mode

The TPS61290x contains an internal switch for bypassing the DC/DC boost converter during bypass mode. When the input voltage is larger than the preset output voltage, the converter seamlessly transitions into 0% duty cycle operation and the bypass FET is fully turned on.

In auto PFM mode, entry in auto bypass mode is triggered by condition where  $V_{OUT} > (1 + 0.5\%) \times V_{OUT\_TAR}$  and  $V_{IN} > V_{OUT} - 20mV$ .

In forced PWM mode, the device enters bypass mode when both of the following conditions are met:

- $V_{OUT} > (1 + 2\%) \times V_{OUT\_TAR}$ .
- Seven consecutive cycle of maximum clamped off-time occurs ( typical  $t_{OFF}$  is 2.25 $\mu s$  of each cycle and total 16 $\mu s$ ).

Bypass mode exit is triggered bypass current limit or  $V_{OUT} < (1-3\%) \times V_{OUT\_TAR}$ .

In auto PFM mode or forced PWM mode, the device enters forced bypass mode when  $V_{IN} > V_{OUT} + 30mV$ . And forced bypass mode exit is triggered bypass current limit.

In bypass mode, the load (RF PA for instance) is directly supplied from the battery for maximum output power, highest efficiency and lowest possible input-to-output voltage difference. The device consumes only a standby current of 23 $\mu A$  (typical). In bypass mode, the device is protected from short-circuit by a very fast current limit detection scheme.

During this operation, the output voltage follows the input voltage and does not fall below the programmed output voltage threshold as the input voltage decreases. The output voltage drop during bypass mode depends on the load current and input voltage, the resulting output voltage is calculated as:

$$V_{OUT} = V_{IN} - (R_{DSON(BP)} \times I_{OUT}) \quad (4)$$

Conversely, the efficiency in bypass mode is defined as:

$$\eta = 1 - R_{DSON(BP)} \frac{I_{OUT}}{V_{IN}} \quad (5)$$

- $R_{DSON(BP)}$  is the typical on-resistance of the bypass FET

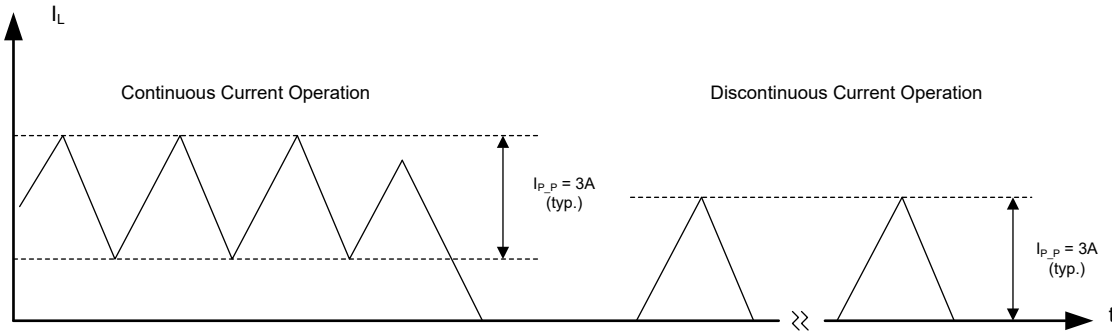
During bypass mode, the TPS61290x device has overcurrent and short-circuit protection by a fast current limit detection scheme. If the current in the bypass FET exceeds approximately 8A (programmable through I<sup>2</sup>C), the bypass FET is turned off, then the TPS61290x enters into output short-to-ground protection mode. Once the overcurrent or short-circuit is released, the TPS61290x goes through the start-up procedure again.

### 7.4.4 Boost Control Operation

The TPS61290x boost converter is controlled by a hysteretic current mode. This controller regulates the output voltage by keeping the inductor ripple current constant around 3.0A and adjusting the offset of this inductor current depending on the output load. Since the input voltage, output voltage and inductor value all affect the rising and falling slopes of inductor ripple current, the switching frequency is not fixed and is determined by the operation condition. At light load, the TPS61290x implements two operating modes, auto PFM and forced PWM, to meet different application requirements. The operating mode is set by changing the state of the MODE\_CTRL bit via I<sup>2</sup>C. When MODE\_CTRL = 00, the device operates in auto PFM mode. When MODE\_CTRL = 10 or 11, the device operates in forced PWM mode.

### 7.4.5 Auto PFM Mode

The TPS61290x integrates the power save mode with pulse frequency modulation (auto PFM) to improve the efficiency at the light load. In this mode, if the required average input current is lower than the average inductor current defined by this constant ripple, the inductor current goes discontinuously to keep the efficiency high under light load condition. The peak inductor current and the valley inductor is limited by approximately 3.0A and 0A separately. If the output current in auto PFM mode is no longer be supported, the TPS61290 exits auto PFM mode and enter PWM mode.



**Figure 7-3. Auto PFM Mode**

#### 7.4.6 Forced PWM Mode

In forced PWM mode, the TPS61290x keeps the inductor current being continuous for the whole load range. When the load current decreases, the output of the internal error amplifier decreases as well to lower the inductor peak current and delivers less power from input to output. The high-side FET is not turned off even if the current through the FET goes negative, which ensuring that the inductor current is continuous. Meanwhile, the switching frequency does not change significantly with the load. In this mode, the minimal switching frequency is limited to 375kHz when input voltage is close to output voltage.

#### 7.4.7 Output Discharge

TPS61290x provides an active pulldown current to quickly discharge output when the EN is logic low or device in I<sup>2</sup>C shutdown mode. With this function, the output voltage is connected to ground through internal circuitry, preventing the output from “floating” or entering into an undetermined state. The output discharge function makes the power on and off sequencing smooth. Pay attention to the output discharge function if use this device in applications such as power multiplexing, because the output discharge circuitry creates a constant current path between the multiplexer output and the ground.

TPS61290x can modify the status of this function by writing the value of the DISCHG bit through I<sup>2</sup>C. When DISCHG = 0, disable output discharge function in I<sup>2</sup>C shutdown mode. When DISCHG = 1, enable output discharge function in shutdown mode. The default value of this bit is 1.

#### 7.4.8 Undervoltage Lockout

The undervoltage lockout circuit prevents the device from malfunctioning at low input voltages and the battery from excessive discharge. The I<sup>2</sup>C control interface and the output stage of the converter are disabled after the falling V<sub>IN</sub> trips the undervoltage lockout threshold V<sub>UVLO\_falling</sub> (1.8V maximum). The device starts operation after the rising V<sub>IN</sub> trips V<sub>UVLO\_rising</sub> threshold (2.2V maximum).

#### 7.4.9 Current Limit Operation

The TPS61290x device features an average inductor current limit scheme.

In DC/DC boost mode, the TPS61290x device employs an average inductor current limit detection scheme, and senses the voltage drop across the synchronous rectifier during the off-time. The default average inductor current limit in boost mode is approximately 11A. When this current limit is reached, if the input voltage continues to decrease, the TPS61290x maintains the output current constant while reducing the output voltage.

The maximum continuous output current (I<sub>OUT(max)</sub>), before entering current limit (CL) operation, is calculated with [Equation 6](#).

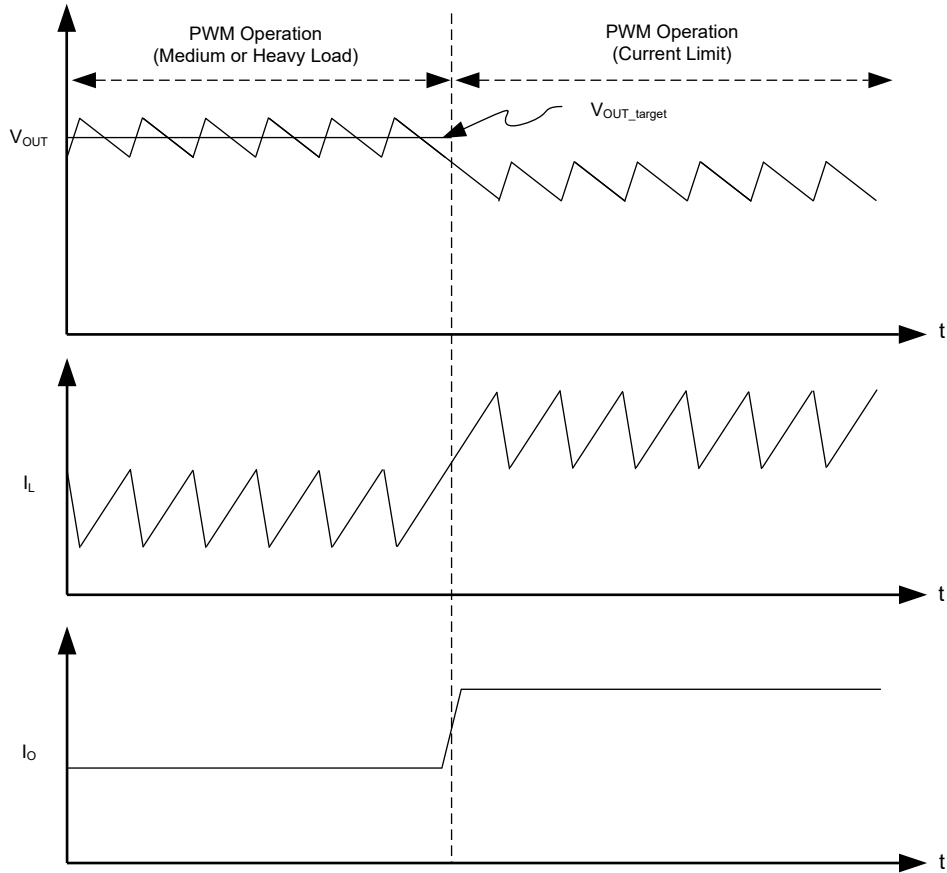
$$I_{OUT(max)} = I_{LIMIT} \times \left( \frac{V_{IN}}{V_{OUT}} \right) \times \eta \quad (6)$$

where

- $\eta$  is the efficiency
- I<sub>OUT(max)</sub> is the maximum output current

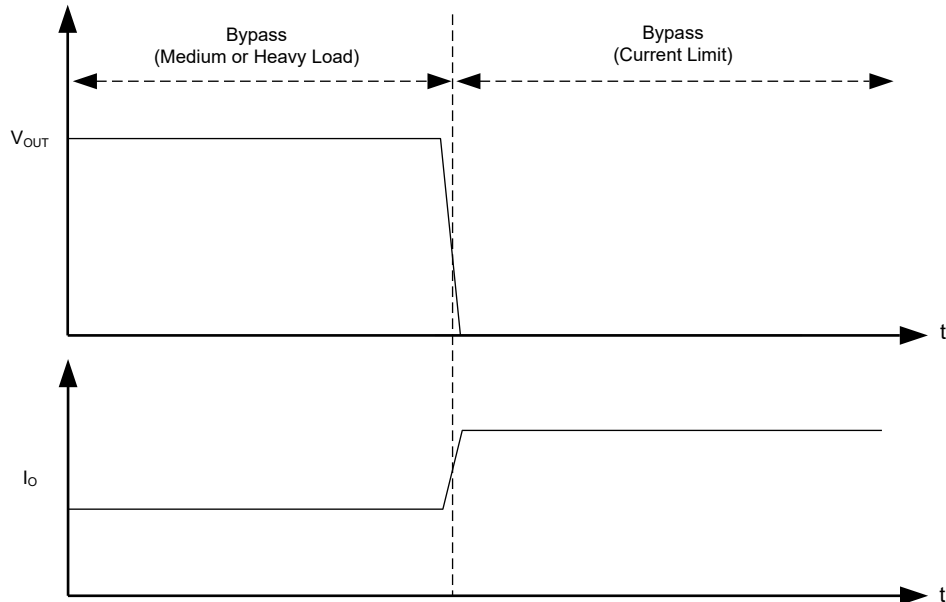
- $I_{LIMIT}$  is the current limit of the input side
- $V_{IN}$  is the input voltage
- $V_{OUT}$  is the output voltage

The output current,  $I_{OUT}$ , is the average of the rectifier ripple current waveform. When the load current increases and causes the average inductor current to exceed the current limit threshold, the off-time increases so that the current decreases this threshold before the next on-time begins (so called frequency fold-back mechanism). When the current limit is reached the output voltage decreases during further load increase.



**Figure 7-4. Operation Scheme of Current Limit in dc/dc Boost Mode**

In true bypass mode, the TPS61290x device employs a hiccup protection scheme. The current limit threshold is set using an I<sup>2</sup>C register. The default current limit in true bypass mode is 8A. When the device hits the current limit, the device turns off the bypass FET after a small delay, ca. 200ns, then the device enters into hiccup mode. After the short-circuit is released, the TPS61290x goes through the soft start-up again.



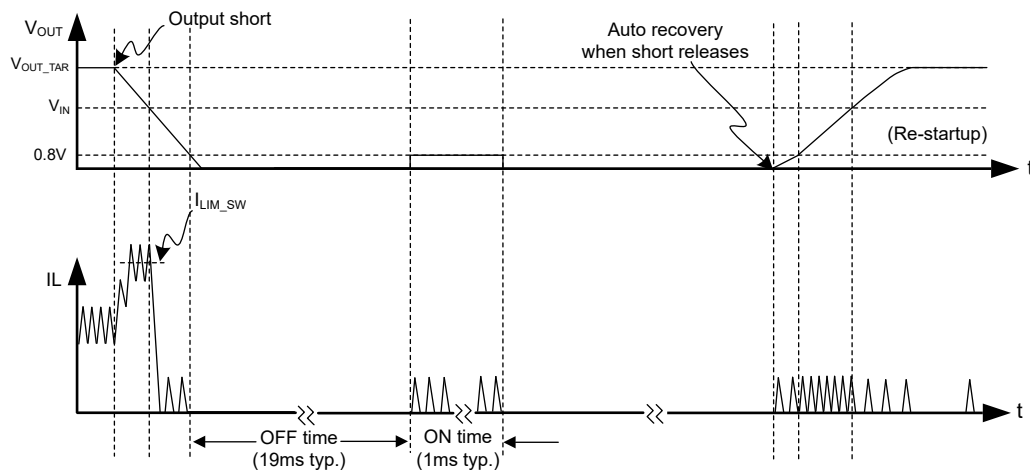
**Figure 7-5. Operation Scheme of Current Limit in True Bypass Mode**

#### 7.4.10 Output Short-to-Ground Protection

The TPS61290x is protected when output short-to-ground (OSGP). The scheme of output OSGP is same as the scheme in start-up phase.

When output is short, the TPS61290x turns off and cycles through a start-up procedure. Once the overcurrent or short-circuit is released, the TPS61290x successfully achieves soft start, then regulates the output voltage.

The hiccup protection mode is disabled using I<sup>2</sup>C.



**Figure 7-6. Hiccup Mode in OSGP**

#### 7.4.11 Thermal Shutdown

As soon as the junction temperature,  $T_J$ , exceeds 165°C (typical) the device goes into thermal shutdown. In this mode, the bypass, high-side and low-side MOSFETs are turned off, and the I<sup>2</sup>C block is active. When the junction temperature falls below the thermal shutdown minus the hysteresis (20°C typical), the device continuously re-start-up and regulate the output voltage.

### 7.4.12 Power-Good Indication Status

The TPS61290x also provide a power-good output bit (PG bit in I<sup>2</sup>C) for signaling the system when the regulator has successfully completed start-up and no faults have occurred. Power good also functions as an early warning flag for excessive die temperature and overload conditions.

- PG is set (bit = 1) when the start-up sequence is successfully completed.
- PG is reset (bit = 0) when the output voltage falls approximately 50mV below the regulation level in boost mode.
- PG is set (bit = 1) when the device is operating in auto bypass mode (that is ENABLE bit = 00 or 01 and  $V_{IN} > V_{OUT}$ ).
- PG is not defined when the device is operating in forced bypass mode (that is ENABLE bit = 10).
- PG is reset (bit = 0) when the device is in shutdown mode (that is ENABLE bit = 11).
- PG is reset (bit = 0) when the device is in short protection mode, thermal shutdown mode.

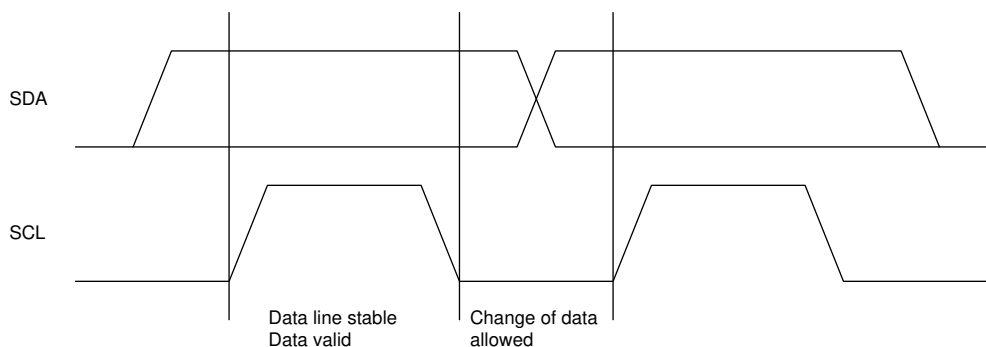
## 7.5 Programming

The TPS61290x uses I<sup>2</sup>C interface for flexible converter parameter programming. I<sup>2</sup>C is a bi-directional 2-wire serial interface. Only two bus lines are required: a serial data line (SDA) and a serial clock line (SCL). I<sup>2</sup>C devices can be considered as controllers or targets when performing data transfers. A controller is the device that initiates a data transfer on the bus and generates the clock signals to permit that transfer. At that time, any device addressed is considered a target.

The TPS61290x operates as a target device with address 75h. Receiving control inputs from the controller device like a microcontroller or a digital signal processor reads and writes the internal registers 00h through 07h. The I<sup>2</sup>C interface of the TPS61290x supports both standard mode (up to 100kbit/s) and fast mode plus (up to 1000kbit/s). Both SDA and SCL must be connected to the positive supply voltage through current sources or pullup resistors. When the bus is free, both lines are in high voltage.

### 7.5.1 Data Validity

The data on the SDA line must be stable during the high level period of the clock. The high level or low level state of the data line can only change when the clock signal on the SCL line is low level. One clock pulse is generated for each data bit transferred.

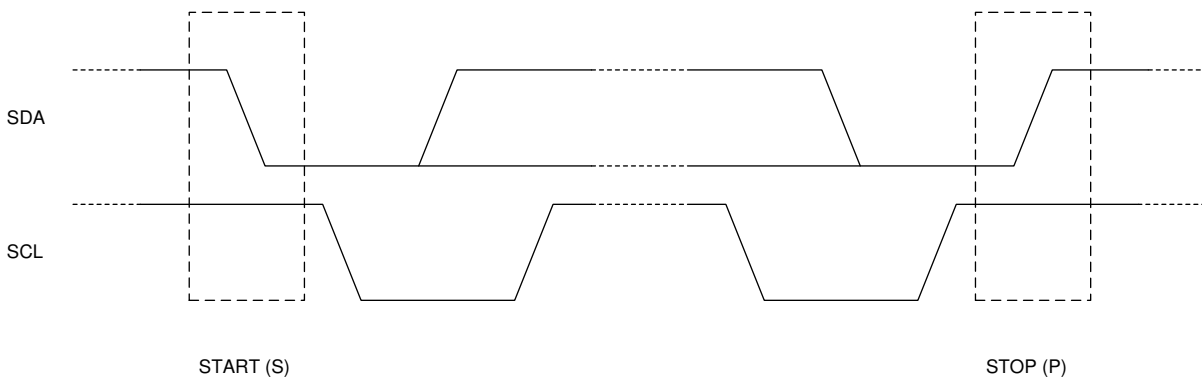


**Figure 7-7. I<sup>2</sup>C Data Validity**

### 7.5.2 START and STOP Conditions

All transactions begin with a START (S) and can be terminated by a STOP (P). A high level to low level transition on the SDA line while SCL is at high level defines a START condition. A low level to high level transition on the SDA line when the SCL is at high level defines a STOP condition.

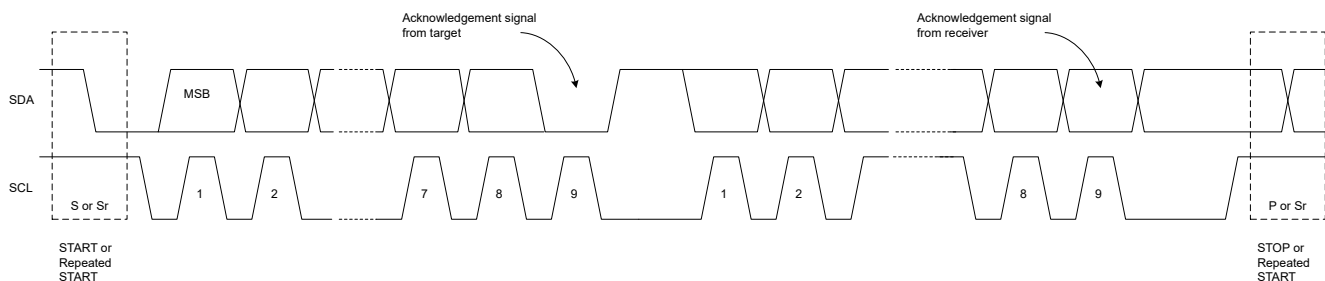
START and STOP conditions are always generated by the controller. The bus is considered busy after the START condition, and free after the STOP condition.



**Figure 7-8. I<sup>2</sup>C START and STOP Conditions**

### 7.5.3 Byte Format

Every byte on the SDA line must be eight bits long. The number of bytes to be transmitted per transfer is unrestricted. Each byte has to be followed by an acknowledge bit. Data is transferred with the most significant bit (MSB) first. If a target cannot receive or transmit another complete byte of data until a target has performed some other function, the target can hold the clock line SCL low to force the controller into a wait state (clock stretching). Data transfer then continues when the target is ready for another byte of data and release the clock line SCL.



**Figure 7-9. Byte Format**

### 7.5.4 Acknowledge (ACK) and Not Acknowledge (NACK)

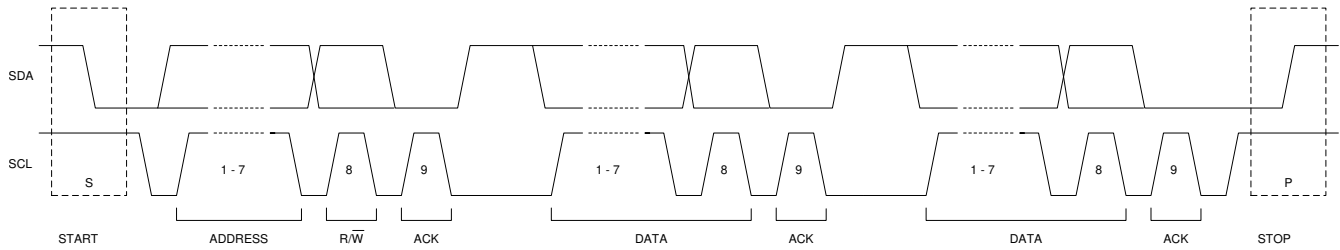
The acknowledge takes place after every byte. The acknowledge bit allows the receiver to signal the transmitter that the byte is successfully received and another byte can be sent. All clock pulses, including the acknowledge ninth clock pulse, are generated by the controller.

The transmitter releases the SDA line during the acknowledge clock pulse so the receiver can pull the SDA line to low level and the SDA line remains stable low level during the high level period of this clock pulse.

The Not Acknowledge signal is when SDA remains high level during the ninth clock pulse. The controller can then generate either a STOP to abort the transfer or a repeated START to start a new transfer.

### 7.5.5 Target Address and Data Direction Bit

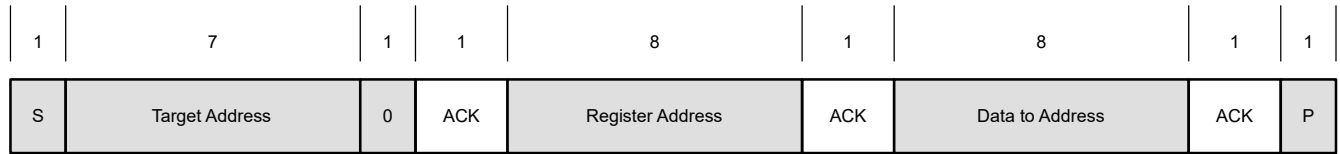
After the START, a target address is sent. This address is seven bits long followed by the eighth bit as a data direction bit (bit R/W). A zero indicates a transmission (WRITE) and a one indicates a request for data (READ).



**Figure 7-10. Target Address and Data Direction**

### 7.5.6 Single Read and Write

Figure 7-11 and Figure 7-12 show the single-byte write and single-byte read format of the I<sup>2</sup>C communication.



**Figure 7-11. Single-byte Write**

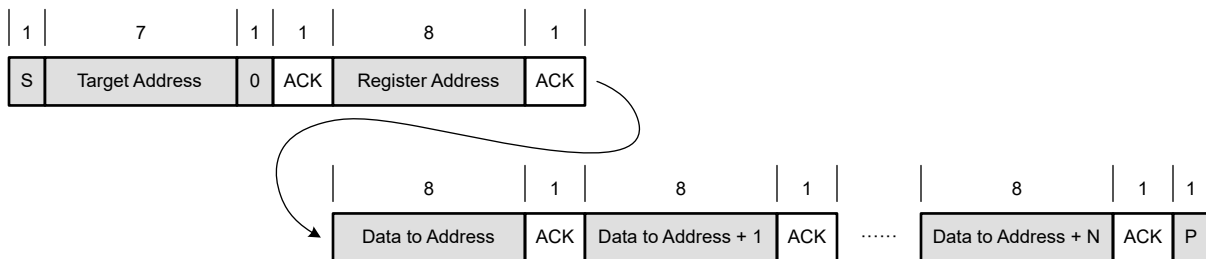


**Figure 7-12. Single-byte Read**

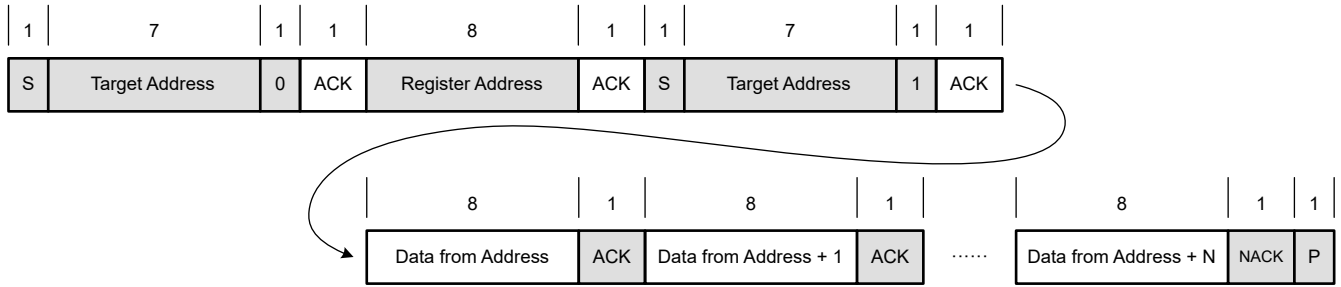
If the register address is not defined, the TPS61290x sends back NACK and goes back to the idle state.

### 7.5.7 Multi-Read and Multi-Write

The TPS61290x supports multi-read and multi-write.



**Figure 7-13. Multi-byte Write**



**Figure 7-14. Multi-byte Read**

## 8 Register Maps

The Configuration Memory Map lists the memory-mapped registers for the device registers. All register offset addresses not listed in The Configuration Memory Map should be considered as reserved locations, and the register contents should not be modified. The default values in the device registers are for the TPS61290 configuration.

**Table 8-1. Device Registers**

Register Address	Register Name	Description
00h	<a href="#">DeviceID Register</a>	Sets Manufacturer ID & Device version ID
01h	<a href="#">CONFIG Register</a>	Sets miscellaneous configuration bits
02h	<a href="#">VOUTFLOORSET Register</a>	Sets the floor output voltage threshold boost / bypass mode change
03h	<a href="#">ILIMBSTSET Register</a>	Sets the input current limit in dc/dc boost mode
04h	<a href="#">VOUTROOFSET Register</a>	Sets the roof output voltage threshold boost / bypass mode change (only valid when GPIO is configured as VSEL function)
05h	<a href="#">STATUS Register</a>	Returns status flags
06h	<a href="#">ILIMPTSET Register</a>	Sets the input current limit in bypass mode
07h	<a href="#">BSTLOOP Register</a>	Sets the internal compensation loop

## 8.1 DeviceID Register

Memory location: 0x00

**Table 8-2. VersionID Register Field Descriptions**

Bit	Field	Type	Reset	Description
7:4	Manufacture ID	R	0111	Manufacturer ID.
3:0	Device ID	R	0000	Device version ID.

## 8.2 CONFIG Register

Memory location: 0x01

**Table 8-3. CONFIG Register Field Descriptions**

Bit	Field	Type	Reset	Description
7	RESET	R/W	0	Device reset bit. 0: Normal operation. or line breaks 1: Default values are set to all internal registers. The device operation is cycled (ON-OFF-ON), that is, the converter is disabled for a short period of time and the output is reset.
6:5	ENABLE	R/W	01	Device enable bit (refer to <a href="#">Operation Mode Setting</a> ). 00 or 01: Device operates in automatic boost mode. 10: Device forced in true bypass mode. 11: Device is in shutdown mode but I <sup>2</sup> C active.
4	HICCUP_MODE	R/W	1	Hiccup mode enable bit. 0 : Hiccup mode disable 1 : Hiccup mode enable
3	DISCHG	R/W	1	Output discharge enable bit. 0: Disable VOUT discharge when the device is in I <sup>2</sup> C shutdown mode. 1: Enable VOUT discharge when the device is in shutdown mode. (refer to <a href="#">Output Discharge</a> )
2	SSFM	R/W	0	Spread modulation control. 0: Spread spectrum modulation is disabled. 1: Spread spectrum modulation is enabled in forced PWM mode
1:0	MODE_CTRL	R/W	00	Device light load functional modes bits. 00: Device operates in <a href="#">Auto PFM Mode</a> . 10 or 11: Device operates in <a href="#">Forced PWM Mode</a> .

### 8.3 VOUTFLOORSET Register

Memory location: 0x02

**Table 8-4. VOUTFLOORSET Register Field Descriptions**

Bit	Field	Type	Reset	Description
7:6	RESERVED	R/W	00	Reserved bit. This bits is reserved for future use. During write operations data intended for this bit is ignored, and during read operations 0 is returned.
5:0	VOUTFLOOR_TH	R/W	1	Output voltage threshold, dc/dc boost / bypass mode change.
		R/W	0	
		R/W	1	000000: 2.85V                      100000: 4.45V
		R/W	0	000001: 2.90V                      100001: 4.50V
		R/W	0	000010: 2.95V                      100010: 4.55V
		R/W	1	000011: 3.00V                      100011: 4.60V
		R/W	1	000100: 3.05V                      100100: 4.65V
		R/W	1	000101: 3.10V                      100101: 4.70V
		R/W	1	000110: 3.15V                      100110: 4.75V
		R/W	1	000111: 3.20V                      100111: 4.80V
		R/W	1	001000: 3.25V                      101000: 4.85V
		R/W	1	001001: 3.30V                      101001: 4.90V
		R/W	1	001010: 3.35V                      101010: 4.95V
		R/W	1	001011: 3.40V                      101011: 5.00V
		R/W	1	001100: 3.45V                      101100: 5.05V
		R/W	1	001101: 3.50V                      101101: 5.10V
		R/W	1	001110: 3.55V                      101110: 5.15V
		R/W	1	001111: 3.60V                      101111: 5.20V
		R/W	1	010000: 3.65V                      110000: 5.25V
		R/W	1	010001: 3.70V                      110001: 5.30V
R/W	1	010010: 3.75V                      110010: 5.35V		
R/W	1	010011: 3.80V                      110011: 5.40V		
R/W	1	010100: 3.85V                      110100: 5.45V		
R/W	1	010101: 3.90V                      110101: 5.50V		
R/W	1	010110: 3.95V                      110110: 2.80V		
R/W	1	010111: 4.00V                      110111: 2.75V		
R/W	1	011000: 4.05V                      111000: 2.70V		
R/W	1	011001: 4.10V                      111001: 2.65V		
R/W	1	011010: 4.15V                      111010: 2.60V		
R/W	1	011011: 4.20V                      111011: 2.55V		
R/W	1	011100: 4.25V                      111100: 2.50V		
R/W	1	011101: 4.30V                      111101: 2.45V		
R/W	1	011110: 4.35V                      111110: 2.40V		
R/W	1	011111: 4.40V                      111111: 2.35V		

## 8.4 ILIMBSTSET Register

Memory location: 0x03

**Table 8-5. ILIMBSTSET Register Field Descriptions**

Bit	Field	Type	Reset	Description
7	RESERVED	R/W	0	Reserved bit. This bit is reserved for future use. During write operations data intended for this bit is ignored, and during read operations 0 is returned.
6	RESERVED	R/W	0	Reserved bit. This bit is reserved for future use. During write operations data intended for this bit is ignored, and during read operations 0 is returned.
5	RESERVED	R/W	0	Reserved bit. This bit is reserved for future use. During write operations data intended for this bit is ignored, and during read operations 0 is returned.
4	RESERVED	R/W	0	Reserved bit. This bit is reserved for future use. During write operations data intended for this bit is ignored, and during read operations 0 is returned.
3:0	ILIM_BOOST	R/W	1	Inductor average current limit in dc/dc boost mode. 0000: 5A 0001: 5.5A 0010: 6A 0011: 6.5A 0100: 7A 0101: 7.5A 0110: 8A 0111: 8.5A 1000: 9A 1001: 9.5A 1010: 10A 1011: 10.5A 1100: 11A 1101: 3.5A 1110: 4A 1111: 4.5A
		R/W	1	
		R/W	0	
		R/W	0	

## 8.5 VOUTROOFSET Register

Memory location: 0x04

**Table 8-6. VOUTROOFSET Register Field Descriptions**

Bit	Field	Type	Reset	Description
7:6	RESERVED	R/W	00	Reserved bit. This bit is reserved for future use. During write operations data intended for this bit is ignored, and during read operations 0 is returned.
5:0	VOUTROOF_TH	R/W	1	Output voltage threshold, dc/dc boost / bypass mode change.
		R/W	1	
		R/W	0	000000: 2.85V                      100000: 4.45V
		R/W	0	000001: 2.90V                      100001: 4.50V
		R/W	0	000010: 2.95V                      100010: 4.55V
		R/W	0	000011: 3.00V                      100011: 4.60V
		R/W	0	000100: 3.05V                      100100: 4.65V
				000101: 3.10V                      100101: 4.70V
				000110: 3.15V                      100110: 4.75V
				000111: 3.20V                      100111: 4.80V
				001000: 3.25V                      101000: 4.85V
				001001: 3.30V                      101001: 4.90V
				001010: 3.35V                      101010: 4.95V
				001011: 3.40V                      101011: 5.00V
				001100: 3.45V                      101100: 5.05V
				001101: 3.50V                      101101: 5.10V
				001110: 3.55V                      101110: 5.15V
001111: 3.60V                      101111: 5.20V				
010000: 3.65V                      110000: 5.25V				
010001: 3.70V                      110001: 5.30V				
010010: 3.75V                      110010: 5.35V				
010011: 3.80V                      110011: 5.40V				
010100: 3.85V                      110100: 5.45V				
010101: 3.90V                      110101: 5.50V				
010110: 3.95V                      110110: 2.80V				
010111: 4.00V                      110111: 2.75V				
011000: 4.05V                      111000: 2.70V				
011001: 4.10V                      111001: 2.65V				
011010: 4.15V                      111010: 2.60V				
011011: 4.20V                      111011: 2.55V				
011100: 4.25V                      111100: 2.50V				
011101: 4.30V                      111101: 2.45V				
011110: 4.35V                      111110: 2.40V				
011111: 4.40V                      111111: 2.35V				

## 8.6 STATUS Register

Memory location: 0x05

**Table 8-7. STATUS Register Field Descriptions**

Bit	Field	Type	Reset	Description
7	TSD	R	0	Thermal shutdown status bit. 0: Normal operation. 1: Thermal shutdown tripped. This flag is reset after readout.
6	CRC_PASS	R	1	OTP test status bit. 0: OTP test failed. This bit is reserved for Test Engineers in TI. 1: Normal operation. This flag is reset after readout.
5	VOUT_START	R	1	Vout status bit. 0: Vout < 0.6V. 1: Vout > 0.6V. This flag is reset after readout.
4	OPMODE	R	1	Device mode of operation status bit. 0: Device operates in bypass mode. 1: Device operates in boost mode.
3	ILIMPT	R	0	Current limit status bit (bypass mode). 0: Normal operation. 1: Indicates that the bypass FET current limit has triggered. This flag is reset after readout.
2	ILIMBST	R	0	Current limit status bit (dc/dc boost mode). 0: Normal operation. 1: Indicates that the average input current limit has triggered for 4ms in dc/dc boost mode. This flag is reset after readout.
1	FL_LD	R	0	Current limit status bit (dc/dc boost mode). 0: Normal operation. 1: Indicates that the average input current limit has triggered in dc/dc boost mode. This flag is reset after readout.
0	PGOOD	R	1	Power Good status bit. 0: Indicates the output voltage is out of regulation. 1: Indicates the output voltage is within its nominal range. This bit is set to 1 if the converter operates in auto bypass mode.

## 8.7 ILIMPTSET Register

Memory location: 0x06

**Table 8-8. ILIMPTSET Register Field Descriptions**

Bit	Field	Type	Reset	Description
7	RESERVED	R/W	0	Reserved bit. This bit is reserved for future use. During write operations data intended for this bit is ignored, and during read operations 0 is returned.
6	RESERVED	R/W	0	Reserved bit. This bit is reserved for future use. During write operations data intended for this bit is ignored, and during read operations 0 is returned.
5:3	ILIM_FPT	R/W	0	Current limit in forced true bypass mode.
		R/W	1	000: 4A 001: 6A 010: 8A 011: 10A 100 ~ 111: Not Defined.
		R/W	0	
2:0	ILIM_APT	R/W	0	Current limit in automatic true bypass mode.
		R/W	1	000: 4A 001: 6A 010: 8A 011: 10A 100 ~ 111: Not Defined.
		R/W	0	

## 8.8 BSTLOOP Register

Memory location: 0x07

**Table 8-9. BSTLOOP Register Field Descriptions**

Bit	Field	Type	Reset	Description
7:3	TI_internal	R/W	00101	TI internal use. Do not read or write.
2:0	RC	R/W	100	Compensation resistor set bit. 000: 400k 001: 450k 010: 500k 011: 550k 100: 200k 101: 250k 110: 300k 111: 350k

## 9 Application and Implementation

### Note

Information in the following applications sections is not part of the TI component specification, and TI does not warrant its accuracy or completeness. TI's customers are responsible for determining suitability of components for their purposes, as well as validating and testing their design implementation to confirm system functionality.

### 9.1 Application Information

The devices are step up dc/dc converters with true bypass function integrated. The devices are typically used as pre-regulators with input voltage ranges from 1.8V to 5.5V that extend the battery run time and overcome input current and input voltage limitations of the system being powered.

While the input voltage higher than boost/bypass threshold, the high-efficient integrated bypass path connects the battery to the powered system directly.

If the input voltage becomes lower than boost/bypass threshold, the device seamlessly transitions into the boost mode operation.

Use the following design procedure to select component values for the both TPS61290x and TPS61290x1.

### 9.2 Typical Application

#### 9.2.1 TPS61290x With 2.5V – 4.35V $V_{IN}$ , 3.4V $V_{OUT}$ , 6A Output Current

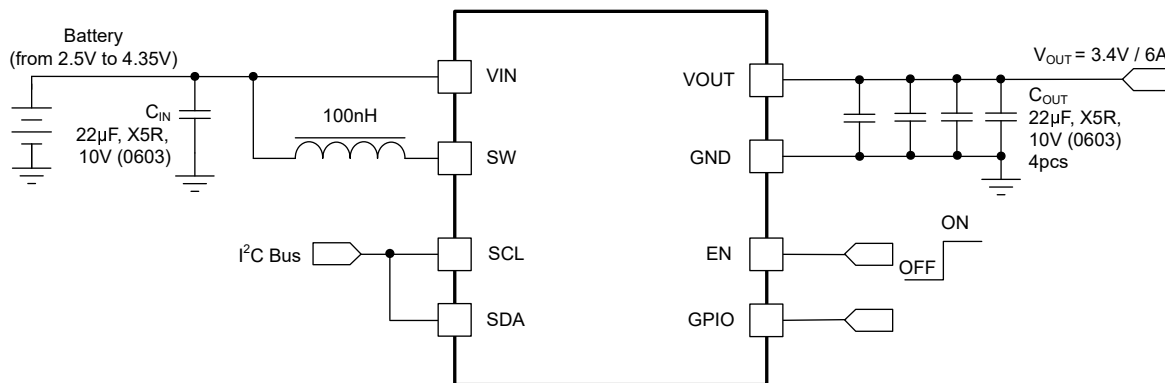


Figure 9-1. TPS61290x With 2.5V – 4.35V  $V_{IN}$ , 3.4V  $V_{OUT}$ , 6A Output Current

#### 9.2.1.1 Design Requirements

Table 9-1. Design Parameters

REFERENCE	DESCRIPTION	SAMPLE VALUES
$V_{IN}$	Input voltage range	2.5V – 4.35V
$V_{OUT}$	Output voltage range at boost mode	$V_{OUT} = 3.4V$
	Output voltage range bypass mode	$V_{OUT} = V_{IN} - I_{OUT} \times R_{DS(ON)\_BYP}$
$I_{OUT}$	Output current	6A (maximum)

## 9.2.1.2 Detailed Design Procedure

### 9.2.1.2.1 Inductor Selection

A boost converter normally requires two main passive components for storing energy during the conversion. An inductor and an output capacitor are required. Selecting an inductor with a saturation current rating higher than the possible peak current flowing through the power switches is advisable.

The inductor peak current varies as a function of the load and the input and output voltages, and is calculated using [Equation 7](#).

$$I_{L(\text{PEAK})} = \frac{V_{\text{IN}} \times D}{2 \times f \times L} + \frac{I_{\text{OUT}}}{(1-D) \times \eta} \quad \text{with } D = 1 - \frac{V_{\text{IN}}}{V_{\text{OUT}}} \quad (7)$$

Selecting an inductor with insufficient saturation performance leads to excessive peak current in the converter. This current can eventually harm the device and reduce the reliability of the device.

When selecting the inductor, as well as the inductance, parameters of importance are: maximum current rating, series resistance, and operating temperature. Enable the inductor DC current rating to be greater than the maximum input average current. See also [Current Limit Operation](#).

$$I_{L(\text{DC})} = \frac{V_{\text{OUT}}}{V_{\text{IN}}} \times \frac{1}{\eta} \times I_{\text{OUT}} \quad (8)$$

The TPS61290x series of step-up converters have been optimized to operate with a effective inductance in the range of 70nH to 130nH. Larger or smaller inductor values are used to optimize the performance of the device for specific operating conditions. See also the [Checking Loop Stability](#) section.

The total losses of the coil consist of both the losses in the DC resistance,  $R_{(\text{DC})}$ , and the following frequency-dependent components:

- The losses in the core material (magnetic hysteresis loss, especially at high switching frequencies)
- Additional losses in the conductor from the skin effect (current displacement at high frequencies)
- Magnetic field losses of the neighboring windings (proximity effect)
- Radiation losses

For good efficiency, enable the inductor DC resistance to be less than 30mΩ. The following inductor series from different suppliers have recommended with the TPS61290x converters.

**Table 9-2. List of Inductors**

SERIES	L (nH)	DIMENSIONS (in mm)	DC INPUT CURRENT LIMIT SETTING	MANUFACTURER <sup>(1)</sup>
HTTP20121B-R11MSR	110	2.0 × 1.2 × 1.2 maximum height	≤ 11A	Cyntec
HTTP20160H-R11MSIR	110	2.0 × 1.6 × 0.8 maximum height	≤ 10.5A	Cyntec
HTTY2016FE-R10MSIR	100	2.0 × 1.6 × 0.65 maximum height	≤ 10A	Cyntec
XGL4012-101	100	4.0 × 4.0 × 1.2 maximum height	≤ 21.5A	Coilcraft
XGL3512-101	100	3.5 × 3.2 × 1.2 maximum height	≤ 15.2A	Coilcraft
XGL3520-101	100	3.5 × 3.2 × 2.0 maximum height	≤ 15.9A	Coilcraft

(1) See the [Third-Party Products Disclaimer](#).

### 9.2.1.2.2 Output Capacitor

For the output capacitor, TI recommends to use small ceramic capacitors placed as close as possible to the VOUT and GND pins of the IC. If, for any reason, the application requires the use of large capacitors that do not fit close to the IC, using a smaller ceramic capacitor in parallel to the large one is highly recommended. To get an estimate of the recommended minimum output capacitance, use [Equation 9](#).

$$C_{\text{MIN}} = \frac{I_{\text{OUT}} \times (V_{\text{OUT}} - V_{\text{IN}})}{f \times \Delta V \times V_{\text{OUT}}} \quad (9)$$

where  $f$  is the switching frequency and  $\Delta V$  is the maximum allowed output ripple.

Use an MLCC capacitor with twice the value of the calculated minimum because of the DC bias effects. This capacitor is required to maintain control loop stability. The output capacitor requires either an X7R or X5R dielectric. Y5V and Z5U dielectric capacitors, aside from the wide variation in capacitance over temperature, become resistive at high frequencies. There are no additional requirements regarding minimum ESR. Larger capacitors cause lower output voltage ripple as well as lower output voltage drop during load transients.

For most of the application cases, TI recommends 3pcs 22 $\mu$ F X5R 10V (0603) MLCC capacitors to use.

In applications featuring high (pulsed) load currents (for example:  $\geq 3.4\text{V} / 6\text{A}$ ), TI recommends to run the converter with a reasonable amount of effective output capacitance and low-ESL device, for instance 4pcs 22 $\mu$ F X5R 10V (0603) MLCC capacitors.

DC bias effect: high cap. ceramic capacitors exhibit DC bias effects, which have a strong influence on the effective capacitance of the device. Therefore the right capacitor value has to be chosen very carefully. Package size and voltage rating in combination with material are responsible for differences between the rated capacitor value and effective capacitance of the capacitor. For instance, a 22 $\mu$ F X5R 6.3V (0603) MLCC capacitor typically shows an effective capacitance of less than 10 $\mu$ F (under 3.4V DC bias and 20mV AC bias condition).

For RF power amplifier applications, the output capacitor loading is combined between the DC/DC converter and the RF Power Amplifier + PA input capacitors.

High values of output capacitance are mainly achieved by putting capacitors in parallel. This action reduces the overall series resistance (ESR) to very low values. This reduction results in almost no voltage ripple at the output and therefore the regulation circuit has no voltage drop to react on. Nevertheless, for accurate output voltage regulation even with low ESR, the regulation loop switches to a pure comparator regulation scheme.

### 9.2.1.2.3 Input Capacitor

Multilayer ceramic capacitors are an excellent choice for input decoupling of the step-up converter as multilayer ceramic capacitors have extremely low ESR and are available in small footprints. Place capacitors as close as possible to the device. A 22 $\mu$ F input capacitor is sufficient for most applications. To further reduce input current ripple without limitations, use larger values.

Take care when using only ceramic input capacitors. When a ceramic capacitor is used at the input and the power is being supplied through long wires, such as from a wall adapter, a load step at the output induces ringing at the  $V_{\text{IN}}$  pin. This ringing couples to the output and be mistaken as loop instability or damage the part. To reduce ringing that occurs between the inductance of the power source leads and  $C_{\text{I}}$ , place "bulk" capacitance (electrolytic or tantalum) between  $C_{\text{I}}$  and the power source.

### 9.2.1.2.4 Checking Loop Stability

The first step of circuit and stability evaluation is to look from a steady-state perspective at the following signals:

- Switching node, SW
- Inductor current,  $I_{\text{L}}$
- Output ripple voltage,  $V_{\text{OUT(AC)}}$

These are the basic signals that must be measured when evaluating a switching converter. Signs of instability in the regulation loop include switching waveforms showing large duty cycle jitter or the output voltage or inductor current showing oscillations. This is often a result of board layout and/or L-C combination.

As a next step in the evaluation of the regulation loop, the load transient response is tested. The time between the application of the load transient and the turn on of the P-channel MOSFET, enable the output capacitor to supply all of the current required by the load.  $V_{OUT}$  immediately shifts by an amount equal to  $\Delta I_{(LOAD)} \times ESR$ , where ESR is the effective series resistance of  $C_{OUT}$ .  $\Delta I_{(LOAD)}$  begins to charge or discharge  $C_{OUT}$  generating a feedback error signal used by the regulator to return  $V_{OUT}$  to the steady-state value. The results are most easily interpreted when the device operates in PWM mode.

During this recovery time, monitor  $V_{OUT}$  for settling time and overshoot or ringing that helps judge the stability of the converter. Without any ringing, the loop has usually more than  $45^\circ$  of phase margin. Because the damping factor of the circuitry is directly related to several resistive parameters (that is, MOSFET  $r_{DS(on)}$ ) that are temperature dependent, the loop stability analysis has to be done over the input voltage range, load current range, and temperature range.

The TPS61290x series of step-up converters have been optimized to operate with the effective inductance in the range of 70nH to 130nH and with the effective output capacitance in the range of 20 $\mu$ F to 100 $\mu$ F. The internal compensation is optimized for an output filter of  $L = 0.1\mu$ H and effective  $C_O = 20\mu$ F.

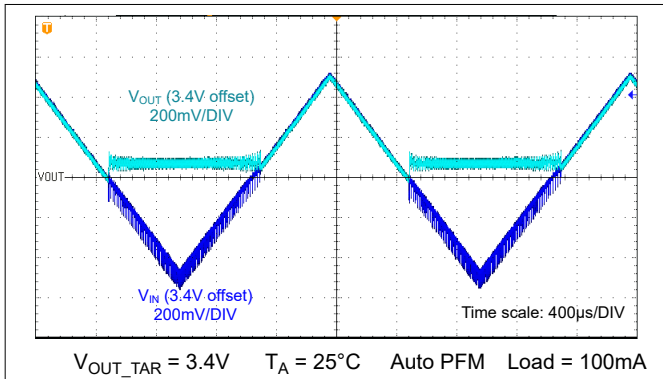
**Table 9-3. Component List**

REFERENCE	DESCRIPTION	PART NUMBER, MANUFACTURER <sup>(1)</sup>
$C_{IN}$	22 $\mu$ F, 10V, 0603, X5R ceramic	GRM187R61A226ME15D
$C_{OUT}$	4 $\times$ 22 $\mu$ F, 10V, 0603, X5R ceramic	4 $\times$ GRM187R61A226ME15D
L	110nH, 6m $\Omega$ , 2.0mm $\times$ 1.2mm $\times$ 1.2mm	HTTP20121B-R11MSR

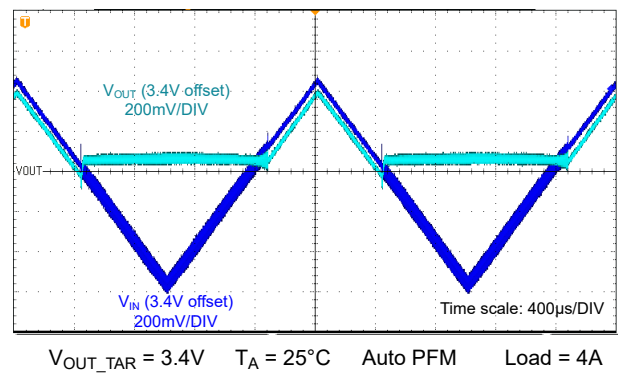
(1) See the [Third-Party Products Disclaimer](#).

### 9.2.1.3 Application Curves

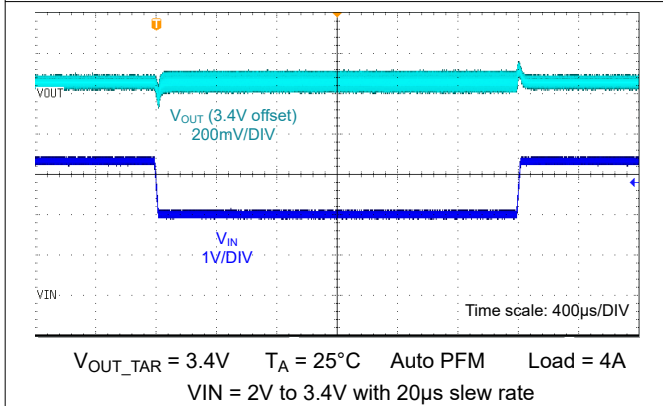
Typical condition  $V_{IN} = 2.5V$  to  $4.35V$ ,  $V_{OUT\_TAR} = 3.4V$ ,  $T_J = 25^\circ C$ , unless otherwise noted



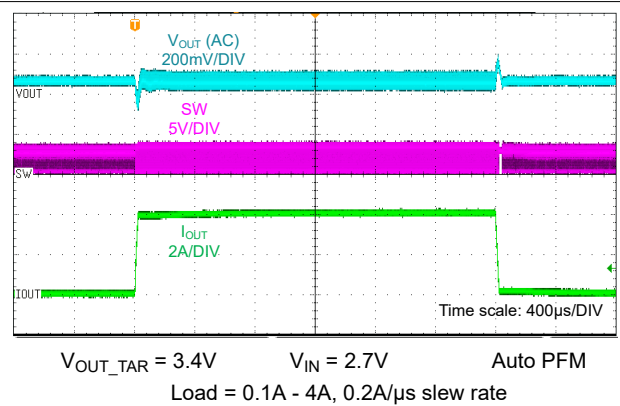
**Figure 9-2. Boost to bypass Mode Exit / Entry**



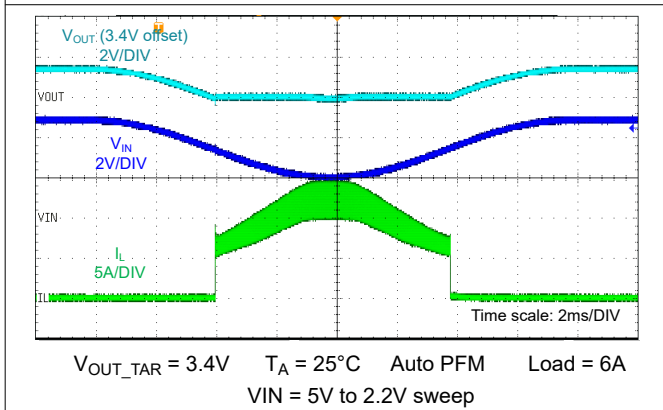
**Figure 9-3. Boost to bypass Mode Exit / Entry**



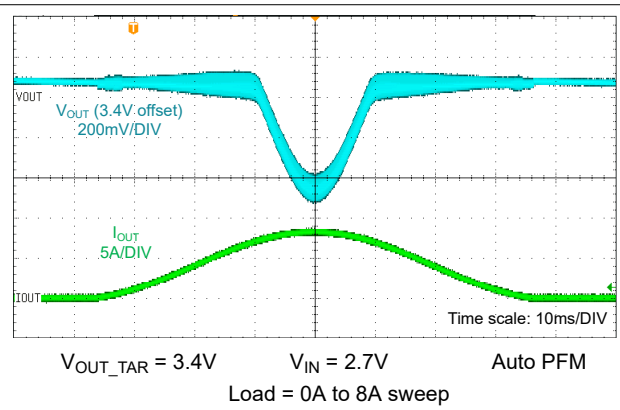
**Figure 9-4. Line Transient Response**



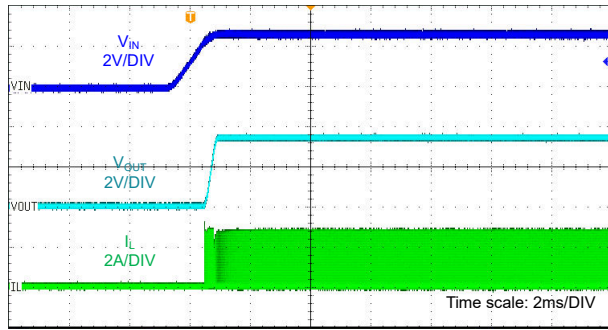
**Figure 9-5. Load Transient Response**



**Figure 9-6. Line Sweep**

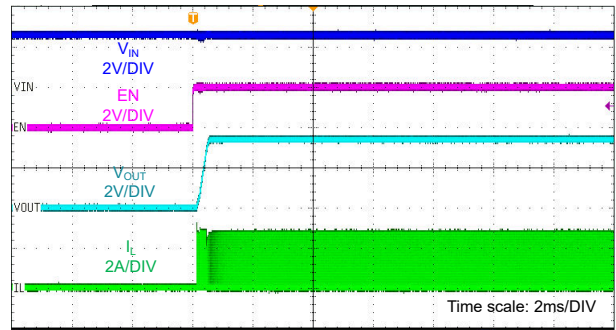


**Figure 9-7. Load Sweep**



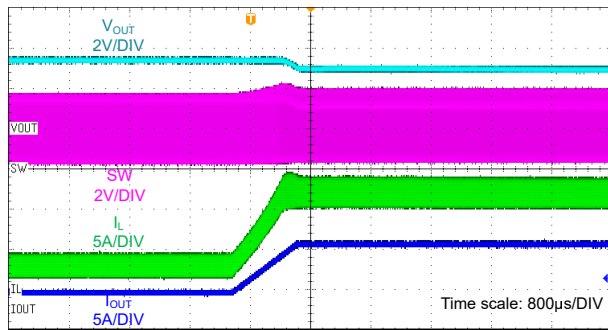
$V_{OUT\_TAR} = 3.4V$   $V_{IN} = 2.7V$  Auto PFM 10 $\Omega$  Load

Figure 9-8. Start-Up by  $V_{IN}$



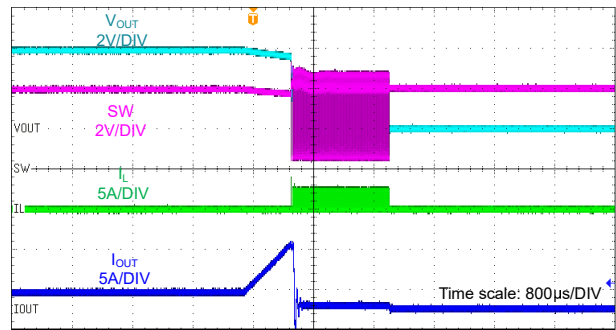
$V_{OUT\_TAR} = 3.4V$   $V_{IN} = 2.7V$  Auto PFM 10 $\Omega$  Load

Figure 9-9. Start-Up by EN



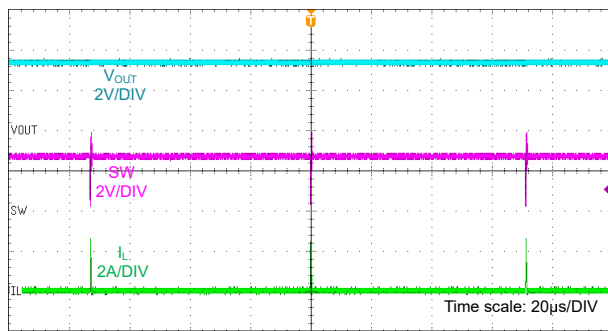
$V_{IN} = 2.7V$  Auto PFM Load = 2A to 8A

Figure 9-10. Current Limit Operation at Boost Mode



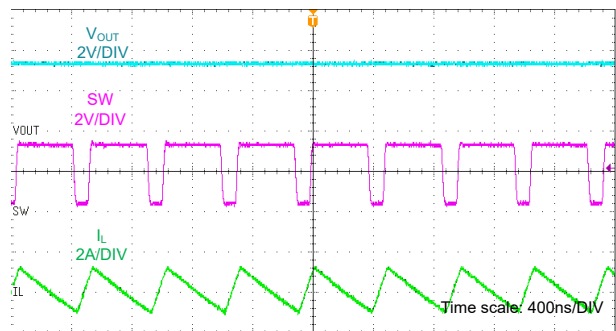
$V_{IN} = 4V$  Auto PFM Load = 2A to 10A

Figure 9-11. Current Limit Operation at Bypass Mode



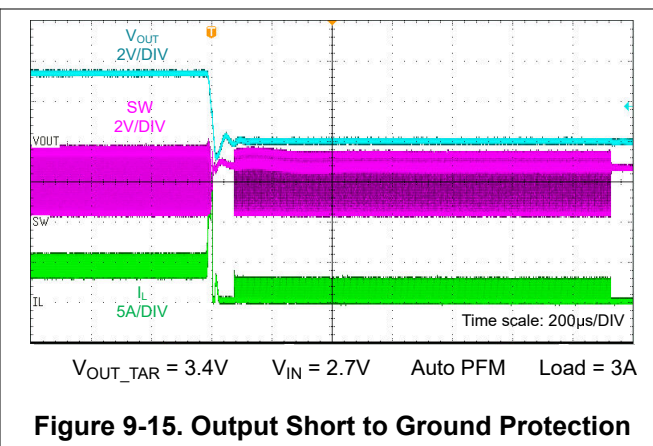
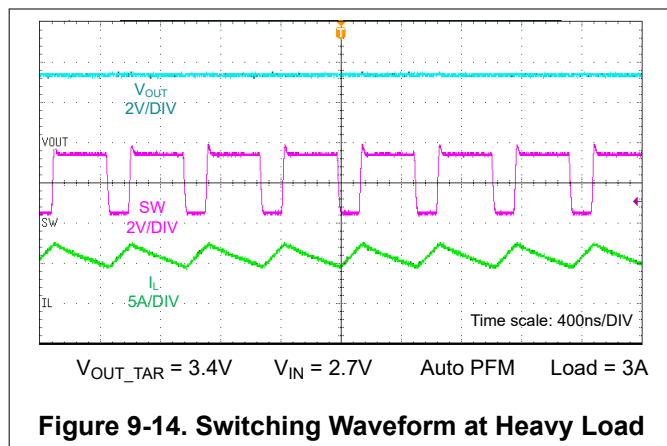
$V_{OUT\_TAR} = 3.4V$   $V_{IN} = 2.7V$  Auto PFM Load = 5mA

Figure 9-12. Switching Waveform at Light Load

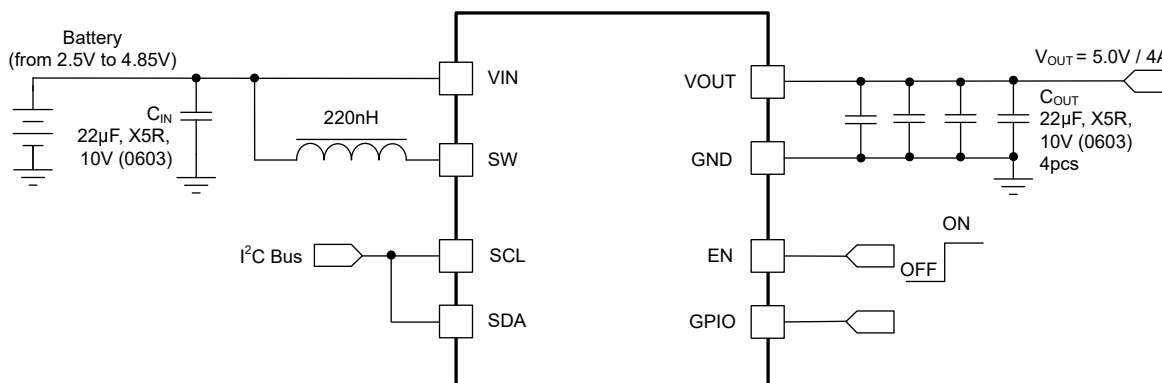


$V_{OUT\_TAR} = 3.4V$   $V_{IN} = 2.7V$  FPWM Load = 5mA

Figure 9-13. Switching Waveform at Light Load



**9.2.2 TPS61290x With 2.5V – 4.85V VIN, 5.0V VOUT, 4A Output Current**



**Figure 9-16. TPS61290x With 2.5V – 4.85V VIN, 5.0V VOUT, 4A Output Current**

**9.2.2.1 Design Requirements**

**Table 9-4. Design Parameters**

REFERENCE	DESCRIPTION	SAMPLE VALUES
V <sub>IN</sub>	Input voltage range	2.5V – 4.85V
V <sub>OUT</sub>	Output voltage range at boost mode	V <sub>OUT</sub> = 5.0V
	Output voltage range bypass mode	V <sub>OUT</sub> = V <sub>IN</sub> – I <sub>OUT</sub> × R <sub>DS(ON)_BYP</sub>
I <sub>OUT</sub>	Output current	4A (maximum)

**Table 9-5. Component List**

REFERENCE	DESCRIPTION	PART NUMBER, MANUFACTURER <sup>(1)</sup>
C <sub>IN</sub>	22µF, 10V, 0603, X5R ceramic	GRM187R61A226ME15D
C <sub>OUT</sub>	4 × 22µF, 10V, 0603, X5R ceramic	4 × GRM187R61A226ME15D
L	220nH, 5mΩ, 4.0mm × 4.0mm × 1.2mm	XGL4012-221MEC

In this application, TI recommends to use inductors from the following different suppliers with the TPS61290x converters.

**Table 9-6. List of Inductors**

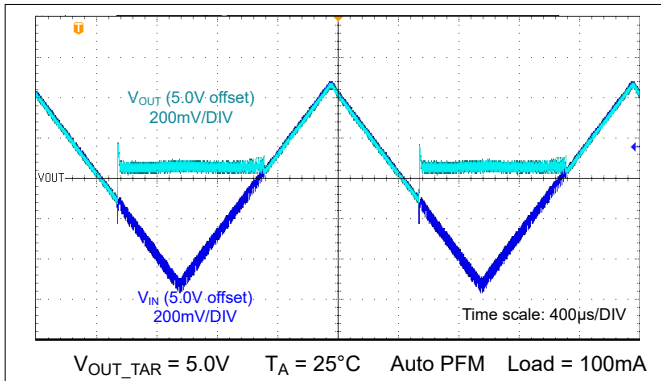
SERIES	L (nH)	DIMENSIONS (in mm)	DC INPUT CURRENT LIMIT SETTING	MANUFACTURER
XGL4012-221	220	4.0 × 4.0 × 1.2 maximum height	≤14.4A	Coilcraft
XGL4012-251	250	4.0 × 4.0 × 1.2 maximum height	≤13.3A	Coilcraft
XGL3512-201	200	3.5 × 3.2 × 1.2 maximum height	≤10.0A	Coilcraft
XGL3520-201	200	3.5 × 3.2 × 2.0 maximum height	≤11.4A	Coilcraft
XGL3520-301	300	3.5 × 3.2 × 2.0 maximum height	≤9.7A	Coilcraft

### 9.2.2.2 Detailed Design Procedure

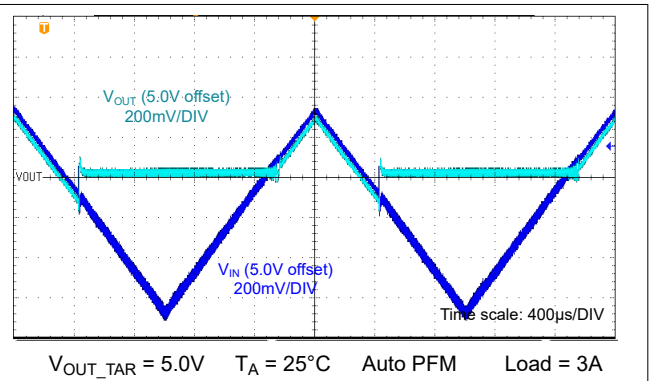
See [Section 9.2.1](#) for all detailed design procedures.

### 9.2.2.3 Application Curves

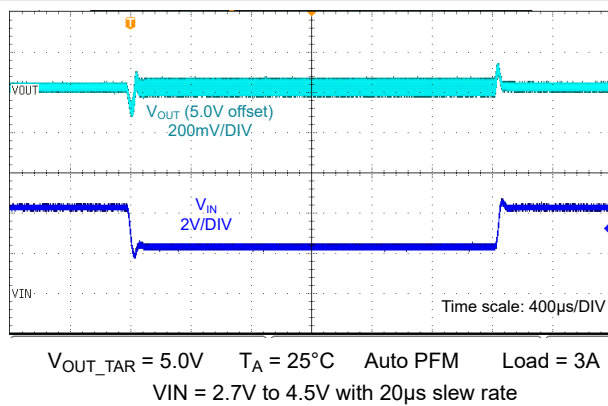
Typical condition  $V_{IN} = 2.5V$  to  $4.85V$ ,  $V_{OUT\_TAR} = 5.0V$ ,  $T_J = 25^\circ C$ , unless otherwise noted.



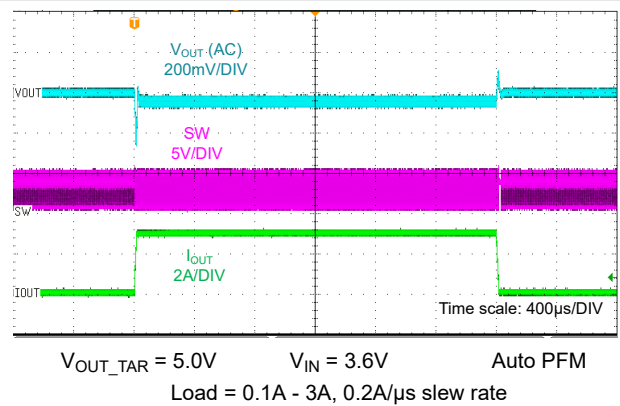
**Figure 9-17. Boost to bypass Mode Exit / Entry**



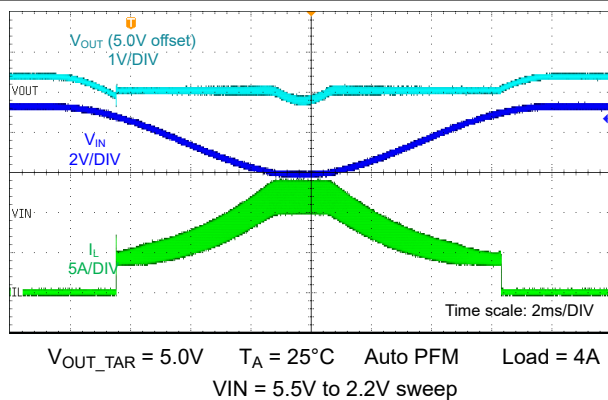
**Figure 9-18. Boost to bypass Mode Exit / Entry**



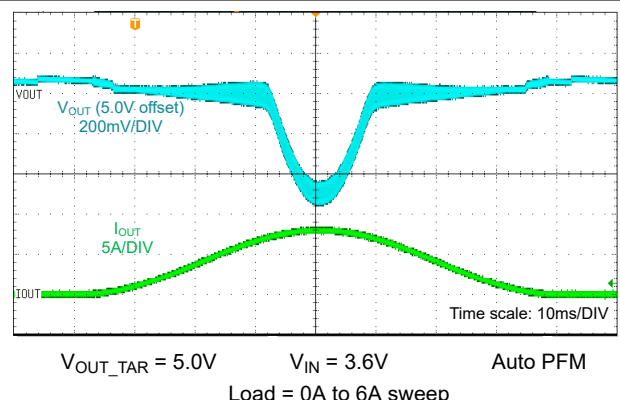
**Figure 9-19. Line Transient Response**



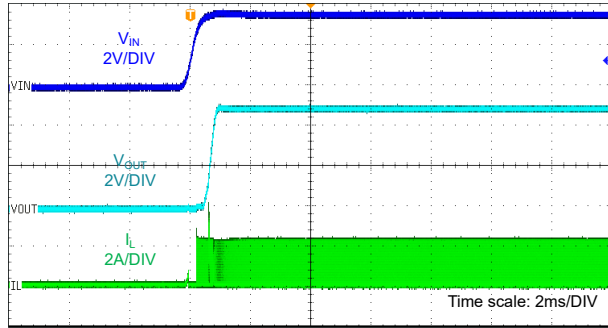
**Figure 9-20. Load Transient Response**



**Figure 9-21. Line Sweep**

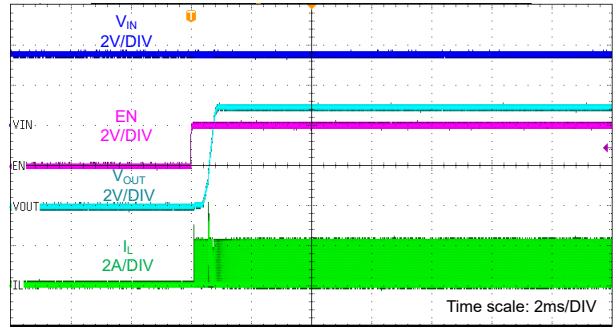


**Figure 9-22. Load Sweep**



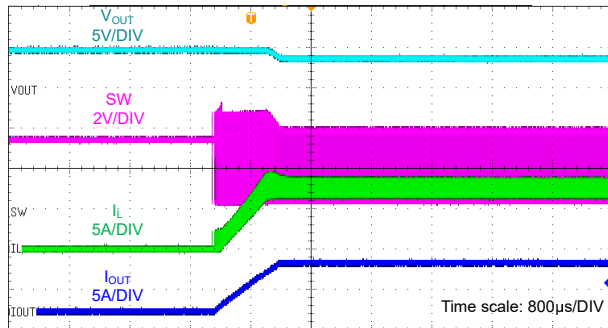
$V_{OUT\_TAR} = 5.0V$   $V_{IN} = 3.6V$  Auto PFM 10 $\Omega$  Load

Figure 9-23. Start-Up by  $V_{IN}$



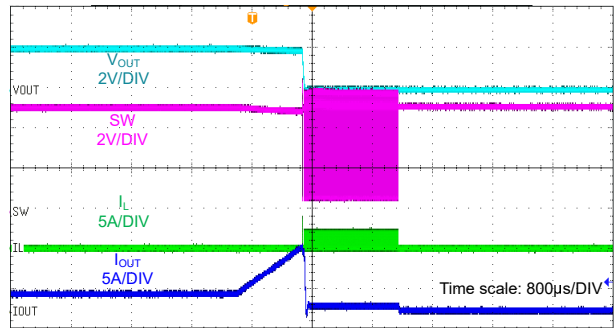
$V_{OUT\_TAR} = 5.0V$   $V_{IN} = 3.6V$  Auto PFM 10 $\Omega$  Load

Figure 9-24. Start-Up by EN



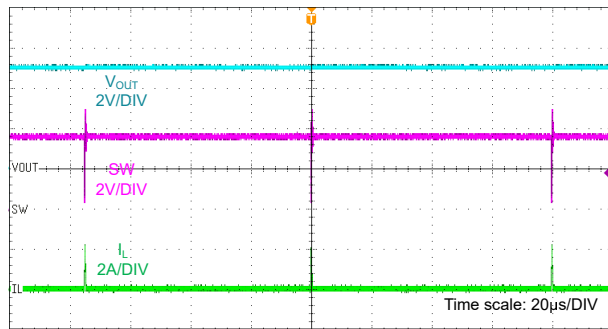
$V_{IN} = 3.6V$  Auto PFM Load = 0A to 6A

Figure 9-25. Current Limit Operation at Boost Mode



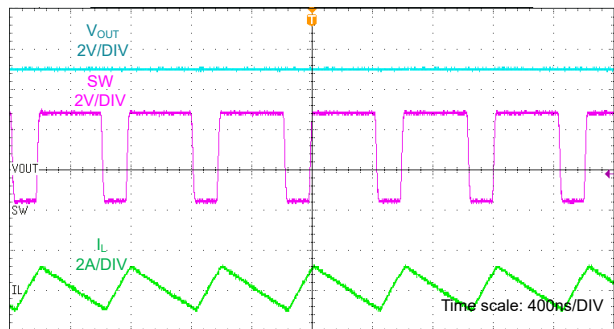
$V_{IN} = 5.2V$  Auto PFM Load = 2A to 10A

Figure 9-26. Current Limit Operation at Bypass Mode



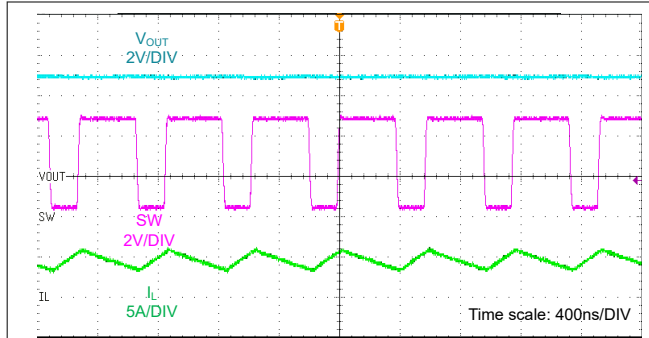
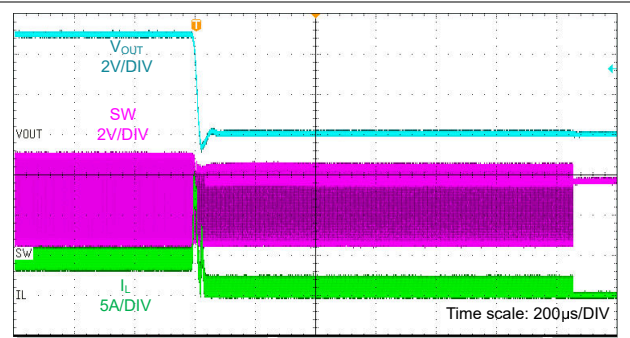
$V_{OUT\_TAR} = 5.0V$   $V_{IN} = 3.6V$  Auto PFM Load = 5mA

Figure 9-27. Switching Waveform at Light Load



$V_{OUT\_TAR} = 5.0V$   $V_{IN} = 3.6V$  FPWM Load = 5mA

Figure 9-28. Switching Waveform at Light Load


**Figure 9-29. Switching Waveform at Heavy Load**

**Figure 9-30. Output Short to Ground Protection**

### 9.3 Power Supply Recommendations

The devices are designed to operate from an input voltage supply range between 1.8V and 5.5V. We'll regulate this input supply. If the input supply is located more than a few inches from the TPS61290x converter, additional bulk capacitance is required in addition to the ceramic bypass capacitors. An electrolytic or tantalum capacitor with a value of 47µF is a typical choice.

### 9.4 Layout

#### 9.4.1 Layout Guidelines

As for all switching power supplies, especially those running at high switching frequency and high current, layout is an important design step. If the layout is not carefully done, the regulator can suffer from instability and noise problems. To maximize efficiency, switching rise and fall times are very fast. To prevent radiation of high-frequency noise (for example, EMI), proper layout of the high-frequency switching path is essential. Minimize the length and area of all traces connected to the SW pin, and always use a ground plane under the switching regulator to minimize interplane coupling.

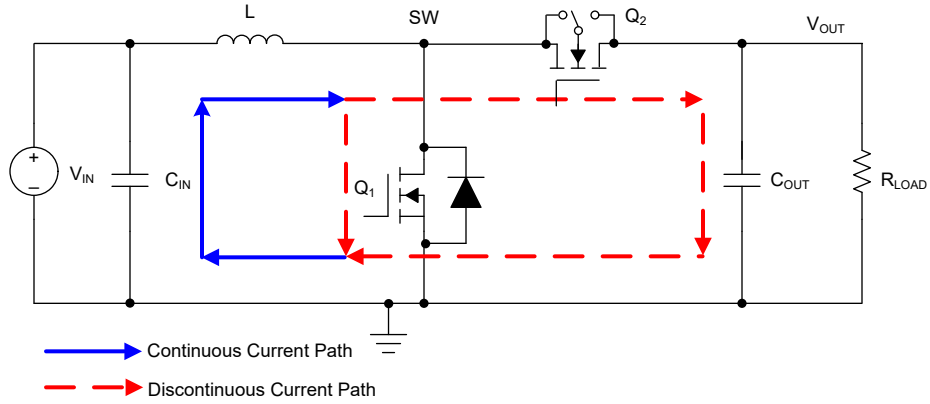
The input capacitor must be close to the VIN pin and PGND pin to reduce the  $I_{in\_put}$  supply ripple.

The power paths of VOUT, output capacitor and PGND must be as small as possible to reduce parasitic inductance.

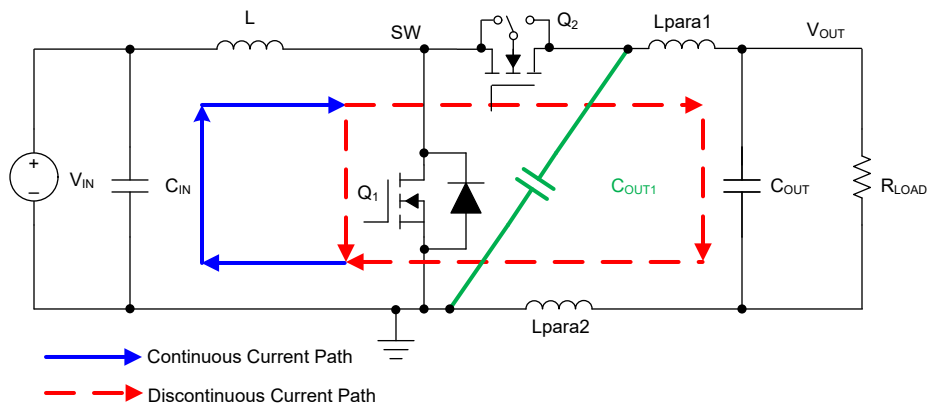
The layout must also be done with good consideration of the thermal as this is device a high power density device. The SW, VOUT, and PGND pins that improves the thermal capabilities of the package must be soldered with the large polygon, using thermal vias underneath the SW pin can improve thermal performance.

Figure 9-31 shows the continuous current path and discontinuous current path in TPS61290x. The blue solid line represents the continuous current path. The red dashed line represents the discontinuous current path. When the power MOSFET  $Q_1$  is turned on, the current flows through the inductor L, power MOSFET  $Q_1$  and back to input voltage supply  $V_{IN}$ . When the power MOSFET  $Q_1$  is turned off, current flows through the inductor L, power MOSFET  $Q_2$ , output capacitor  $C_{OUT}$  and back to input voltage supply  $V_{IN}$ .

Figure 9-32 shows the PCB parasitic inductors in discontinuous current path. The loop formed by power MOSFET  $Q_1$ , power MOSFET  $Q_2$ , output capacitor  $C_{OUT}$  must be minimized as short as possible because the PCB parasitic inductors in these high di/dt current paths generate high voltage spikes at output and across power MOSFETs. The spikes and ringing at switch node SW is the source of EMI and can cause power MOSFET overvoltage damage. To minimize the influences of PCB parasitic inductors Lpara1, Lpara2, and Lpara3, the power MOSFET  $Q_1$ , power MOSFET  $Q_2$  must be placed close to each other. A low ESL and ESR X5R or X7R dielectric ceramic capacitor  $C_{OUT1}$  is better to be placed across to power MOSFET  $Q_2$  and power MOSFET  $Q_1$  as shown in Figure 9-32.



**Figure 9-31. Continuous and Discontinuous Current Paths**



**Figure 9-32. PCB Parasitic Inductors in Discontinuous Current Paths**

### 9.4.2 Layout Example

Figure 9-33 shows the recommended output capacitor placements for the TPS61290x. Several 0603 package X5R dielectric capacitors are placed in parallel and close to the IC. This layout is the easy and recommended way because this way has minimum parasitic inductance.

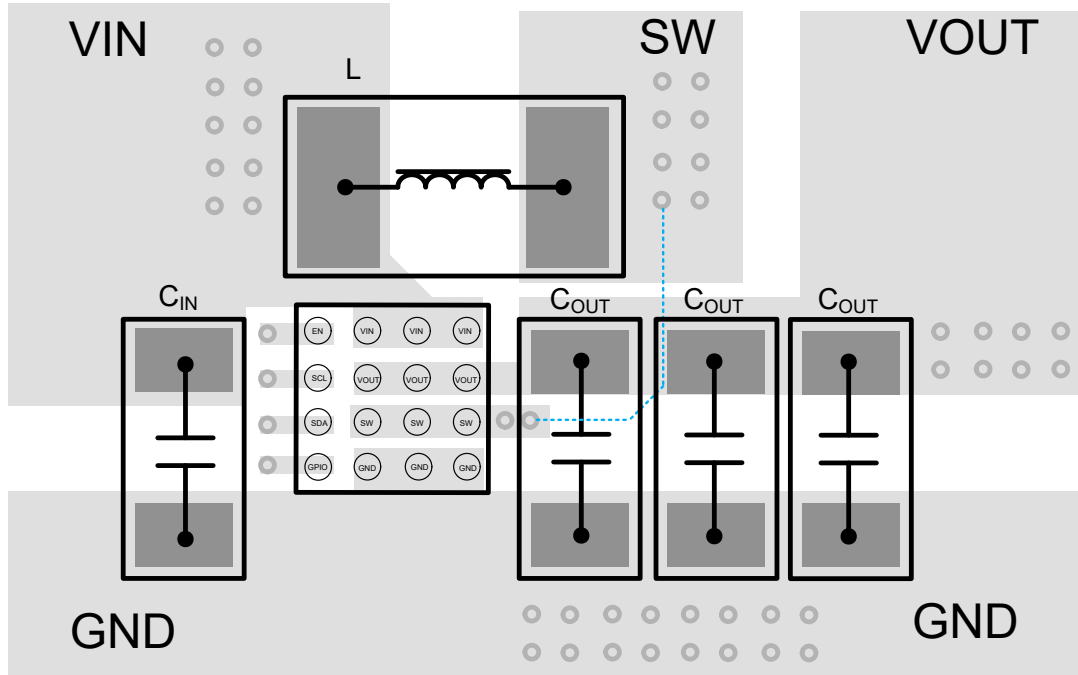


Figure 9-33. Suggested Layout (Top)

### 9.4.3 Thermal Information

Implementation of integrated circuits in low-profile and fine-pitch surface-mount packages typically requires special attention to power dissipation. Many system-dependent issues such as thermal coupling, airflow, added heat sinks and convection surfaces, and the presence of other heat-generating components affect the power-dissipation limits of a given component.

Three basic approaches for enhancing thermal performance are listed below:

- Improving the power dissipation capability of the PCB design
- Improving the thermal coupling of the component to the PCB
- Introducing airflow in the system

The importance of power demand in portable designs is ever-growing, leading designers to select what is best between efficiency, power dissipation, and design size. Due to integration and miniaturization, junction temperature increases significantly which can lead to bad application behaviors (that is, premature thermal shutdown or worst case reduce device reliability).

Junction-to-ambient thermal resistance is highly application and board-layout dependent. In applications where high maximum power dissipation exists, pay special attention to thermal dissipation issues in board design. Keep the device operating junction temperature ( $T_J$ ) below 125°C.

## 10 Device and Documentation Support

### 10.1 Device Support

#### 10.1.1 Third-Party Products Disclaimer

TI'S PUBLICATION OF INFORMATION REGARDING THIRD-PARTY PRODUCTS OR SERVICES DOES NOT CONSTITUTE AN ENDORSEMENT REGARDING THE SUITABILITY OF SUCH PRODUCTS OR SERVICES OR A WARRANTY, REPRESENTATION OR ENDORSEMENT OF SUCH PRODUCTS OR SERVICES, EITHER ALONE OR IN COMBINATION WITH ANY TI PRODUCT OR SERVICE.

### 10.2 Receiving Notification of Documentation Updates

To receive notification of documentation updates, navigate to the device product folder on [ti.com](http://ti.com). Click on *Notifications* to register and receive a weekly digest of any product information that has changed. For change details, review the revision history included in any revised document.

### 10.3 Support Resources

[TI E2E™ support forums](#) are an engineer's go-to source for fast, verified answers and design help — straight from the experts. Search existing answers or ask your own question to get the quick design help you need.

Linked content is provided "AS IS" by the respective contributors. They do not constitute TI specifications and do not necessarily reflect TI's views; see TI's [Terms of Use](#).

### 10.4 Trademarks

TI E2E™ is a trademark of Texas Instruments.  
All trademarks are the property of their respective owners.

### 10.5 Electrostatic Discharge Caution



This integrated circuit can be damaged by ESD. Texas Instruments recommends that all integrated circuits be handled with appropriate precautions. Failure to observe proper handling and installation procedures can cause damage.

ESD damage can range from subtle performance degradation to complete device failure. Precision integrated circuits may be more susceptible to damage because very small parametric changes could cause the device not to meet its published specifications.

### 10.6 Glossary

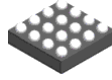
[TI Glossary](#) This glossary lists and explains terms, acronyms, and definitions.

## 11 Revision History

DATE	REVISION	NOTES
June 2026	*	Initial Release

## 12 Mechanical, Packaging, and Orderable Information

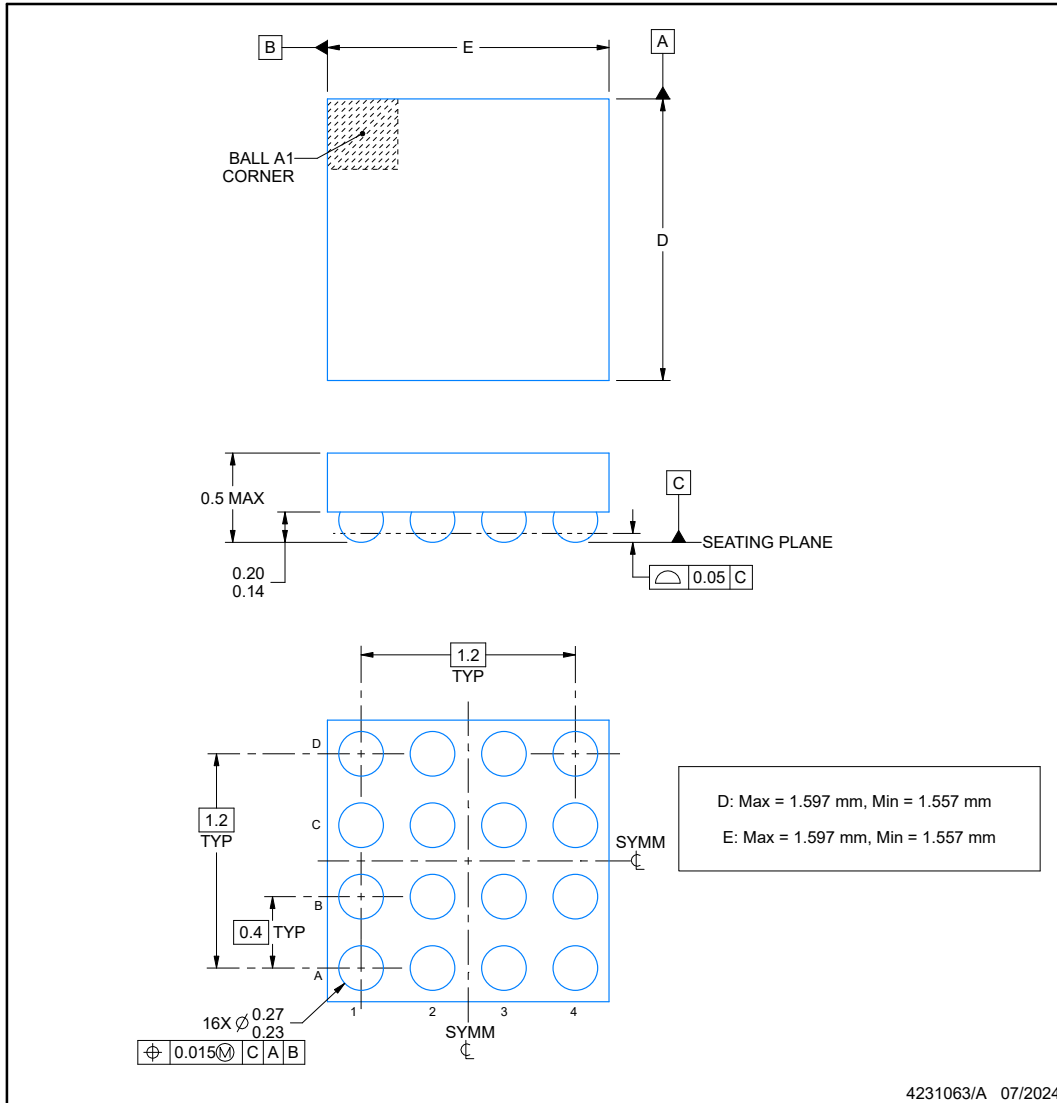
The following pages include mechanical, packaging, and orderable information. This information is the most current data available for the designated devices. This data is subject to change without notice and revision of this document. For browser-based versions of this data sheet, refer to the left-hand navigation.



**YBG0016-C01**

**PACKAGE OUTLINE**  
**DSBGA - 0.5 mm max height**

DIE SIZE BALL GRID ARRAY



NOTES:

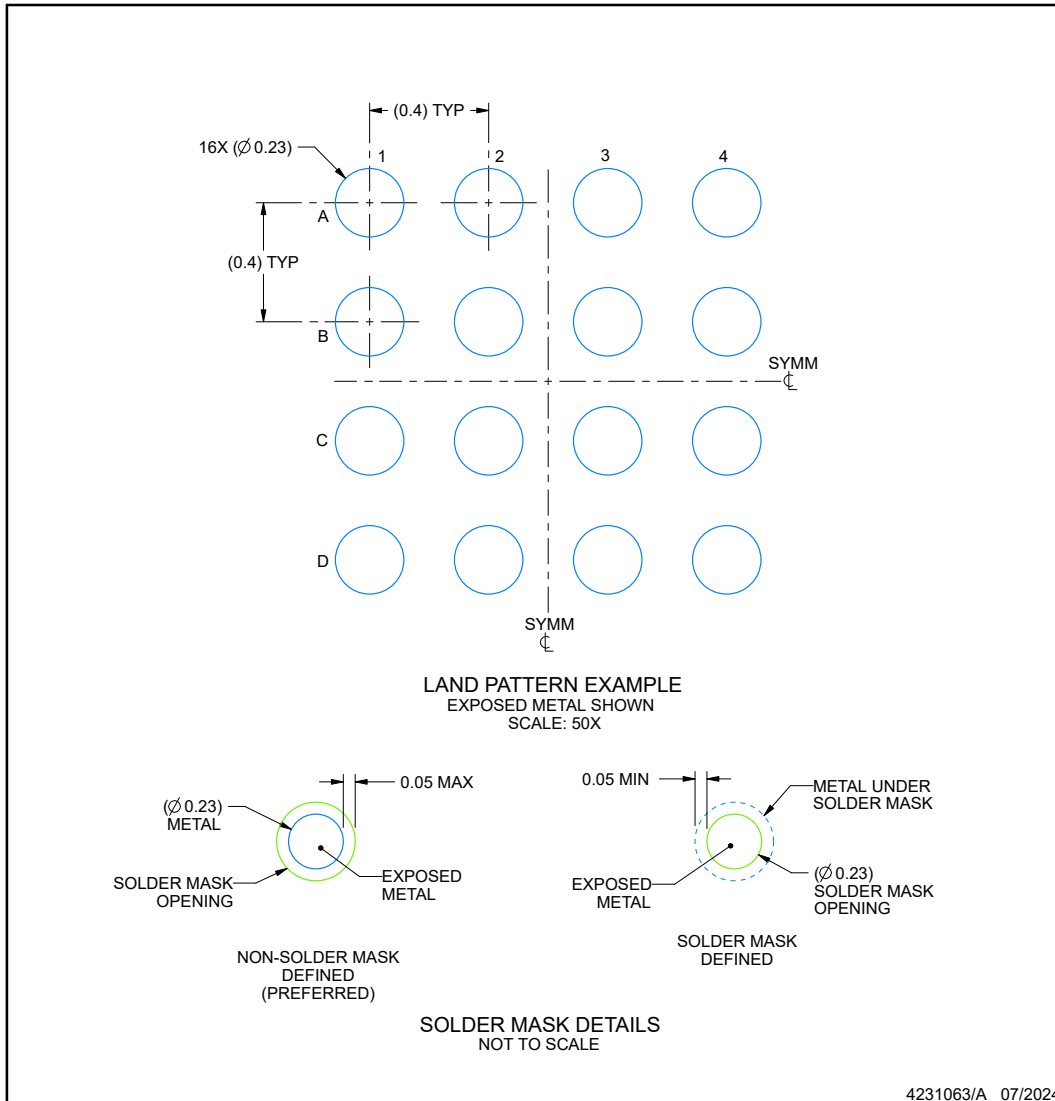
1. All linear dimensions are in millimeters. Any dimensions in parenthesis are for reference only. Dimensioning and tolerancing per ASME Y14.5M.
2. This drawing is subject to change without notice.

## EXAMPLE BOARD LAYOUT

**YBG0016-C01**

**DSBGA - 0.5 mm max height**

DIE SIZE BALL GRID ARRAY



NOTES: (continued)

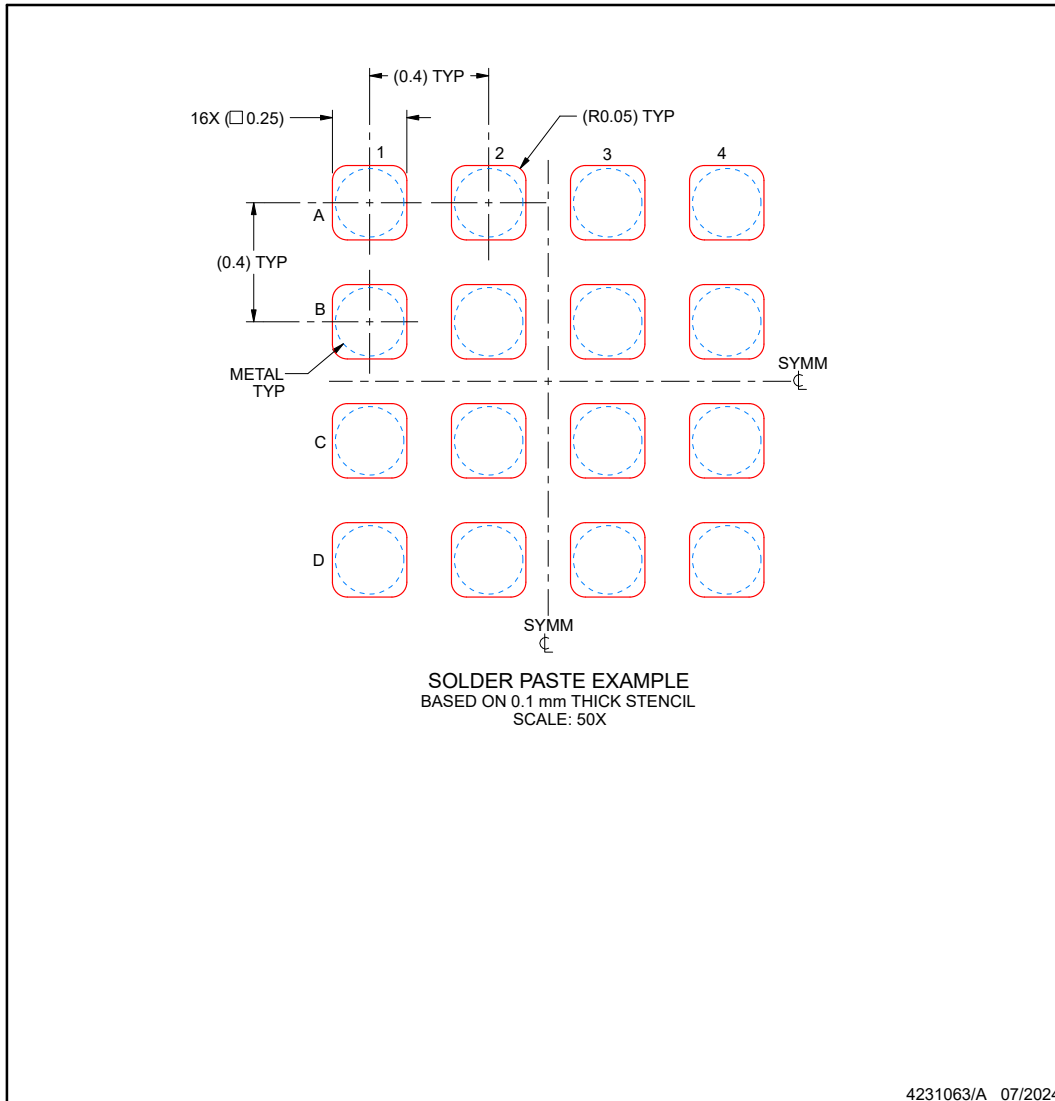
- Final dimensions may vary due to manufacturing tolerance considerations and also routing constraints. See Texas Instruments Literature No. SNVA009 ([www.ti.com/lit/snva009](http://www.ti.com/lit/snva009)).

## EXAMPLE STENCIL DESIGN

**YBG0016-C01**

**DSBGA - 0.5 mm max height**

DIE SIZE BALL GRID ARRAY



NOTES: (continued)

4. Laser cutting apertures with trapezoidal walls and rounded corners may offer better paste release.

## PACKAGING INFORMATION

Orderable part number	Status (1)	Material type (2)	Package   Pins	Package qty   Carrier	RoHS (3)	Lead finish/ Ball material (4)	MSL rating/ Peak reflow (5)	Op temp (°C)	Part marking (6)
<a href="#">TPS612901YBGR</a>	Active	Production	DSBGA (YBG)   16	3000   LARGE T&R	Yes	SNAGCU	Level-1-260C-UNLIM	-	25B

(1) **Status:** For more details on status, see our [product life cycle](#).

(2) **Material type:** When designated, preproduction parts are prototypes/experimental devices, and are not yet approved or released for full production. Testing and final process, including without limitation quality assurance, reliability performance testing, and/or process qualification, may not yet be complete, and this item is subject to further changes or possible discontinuation. If available for ordering, purchases will be subject to an additional waiver at checkout, and are intended for early internal evaluation purposes only. These items are sold without warranties of any kind.

(3) **RoHS values:** Yes, No, RoHS Exempt. See the [TI RoHS Statement](#) for additional information and value definition.

(4) **Lead finish/Ball material:** Parts may have multiple material finish options. Finish options are separated by a vertical ruled line. Lead finish/Ball material values may wrap to two lines if the finish value exceeds the maximum column width.

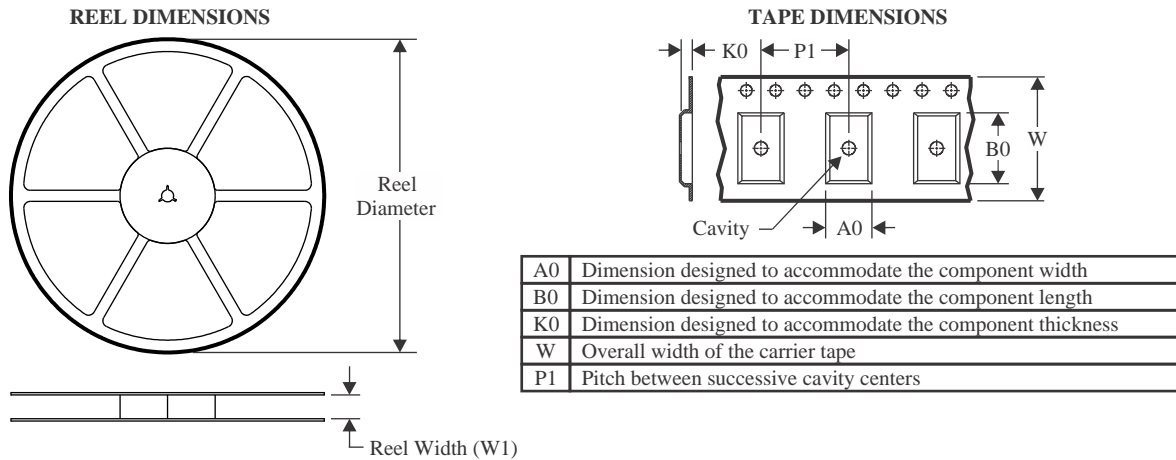
(5) **MSL rating/Peak reflow:** The moisture sensitivity level ratings and peak solder (reflow) temperatures. In the event that a part has multiple moisture sensitivity ratings, only the lowest level per JEDEC standards is shown. Refer to the shipping label for the actual reflow temperature that will be used to mount the part to the printed circuit board.

(6) **Part marking:** There may be an additional marking, which relates to the logo, the lot trace code information, or the environmental category of the part.

Multiple part markings will be inside parentheses. Only one part marking contained in parentheses and separated by a "-" will appear on a part. If a line is indented then it is a continuation of the previous line and the two combined represent the entire part marking for that device.

**Important Information and Disclaimer:** The information provided on this page represents TI's knowledge and belief as of the date that it is provided. TI bases its knowledge and belief on information provided by third parties, and makes no representation or warranty as to the accuracy of such information. Efforts are underway to better integrate information from third parties. TI has taken and continues to take reasonable steps to provide representative and accurate information but may not have conducted destructive testing or chemical analysis on incoming materials and chemicals. TI and TI suppliers consider certain information to be proprietary, and thus CAS numbers and other limited information may not be available for release.

In no event shall TI's liability arising out of such information exceed the total purchase price of the TI part(s) at issue in this document sold by TI to Customer on an annual basis.

**TAPE AND REEL INFORMATION**

**QUADRANT ASSIGNMENTS FOR PIN 1 ORIENTATION IN TAPE**


\*All dimensions are nominal

Device	Package Type	Package Drawing	Pins	SPQ	Reel Diameter (mm)	Reel Width W1 (mm)	A0 (mm)	B0 (mm)	K0 (mm)	P1 (mm)	W (mm)	Pin1 Quadrant
TPS612901YBGR	DSBGA	YBG	16	3000	180.0	8.4	1.68	1.72	0.62	4.0	8.0	Q1

**TAPE AND REEL BOX DIMENSIONS**


\*All dimensions are nominal

Device	Package Type	Package Drawing	Pins	SPQ	Length (mm)	Width (mm)	Height (mm)
TPS612901YBGR	DSBGA	YBG	16	3000	182.0	182.0	20.0

## IMPORTANT NOTICE AND DISCLAIMER

TI PROVIDES TECHNICAL AND RELIABILITY DATA (INCLUDING DATASHEETS), DESIGN RESOURCES (INCLUDING REFERENCE DESIGNS), APPLICATION OR OTHER DESIGN ADVICE, WEB TOOLS, SAFETY INFORMATION, AND OTHER RESOURCES "AS IS" AND WITH ALL FAULTS, AND DISCLAIMS ALL WARRANTIES, EXPRESS AND IMPLIED, INCLUDING WITHOUT LIMITATION ANY IMPLIED WARRANTIES OF MERCHANTABILITY, FITNESS FOR A PARTICULAR PURPOSE OR NON-INFRINGEMENT OF THIRD PARTY INTELLECTUAL PROPERTY RIGHTS.

These resources are intended for skilled developers designing with TI products. You are solely responsible for (1) selecting the appropriate TI products for your application, (2) designing, validating and testing your application, and (3) ensuring your application meets applicable standards, and any other safety, security, regulatory or other requirements.

These resources are subject to change without notice. TI grants you permission to use these resources only for development of an application that uses the TI products described in the resource. Other reproduction and display of these resources is prohibited. No license is granted to any other TI intellectual property right or to any third party intellectual property right. TI disclaims responsibility for, and you fully indemnify TI and its representatives against any claims, damages, costs, losses, and liabilities arising out of your use of these resources.

TI's products are provided subject to [TI's Terms of Sale](#), [TI's General Quality Guidelines](#), or other applicable terms available either on [ti.com](http://ti.com) or provided in conjunction with such TI products. TI's provision of these resources does not expand or otherwise alter TI's applicable warranties or warranty disclaimers for TI products. Unless TI explicitly designates a product as custom or customer-specified, TI products are standard, catalog, general purpose devices.

TI objects to and rejects any additional or different terms you may propose.

Copyright © 2026, Texas Instruments Incorporated

Last updated 10/2025