

## TPS54140A 具有 Eco-mode™ 的 1.5A、42V 降压 DC/DC 转换器

### 1 特性

- 输入电压范围：3.5V 到 42V
- 200mΩ 高侧金属氧化物半导体场效应晶体管 (MOSFET)
- 借助脉冲跳跃在轻负载时实现高效率 Eco-mode™
- 为了实现更加精准的欠压锁定 (UVLO) 电压，此器件的使能阈值比 TPS54140 更严密
- 可调节的 UVLO 电压和迟滞
- 116μA 静态工作电流
- 1.3μA 关断电流
- 100kHz 至 2.5MHz 开关频率
- 同步至外部时钟
- 可调缓启动/排序
- 欠压 (UV) 和过流 (OV) 电源正常输出
- 0.8V 内部电压基准
- 带有 PowerPAD 的 MSOP10 封装和 3mm × 3mm VSON-10 封装™
- 由 WEBENCH® 和 SwitcherPro™ 软件工具提供支持

### 2 应用范围

- 12V 和 24V 工业及商用低功耗系统
- 汽车售后加装配件：视频、全球卫星定位 (GPS)、娱乐系统

简化电路原理图

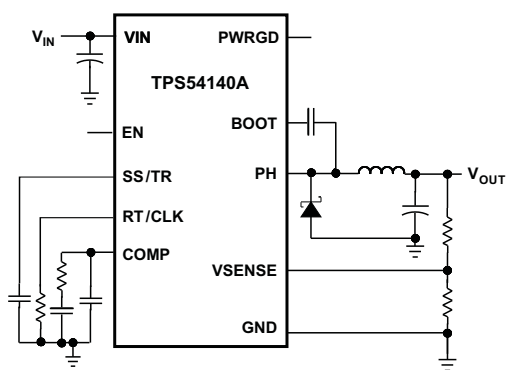

### 3 说明

TPS54140A 器件是一款集成有高侧 MOSFET 的 42V、1.5A、降压稳压器。它采用电流模式控制，可实现简单的外部补偿和灵活的组件选择。其低纹波脉冲跳跃模式可将无负载的稳压输出电源电流减小至 116μA。通过使用使能引脚，可将关断电源电流减少至 1.3μA。

其欠压锁定电压在内部设定为 2.5V，但可用使能引脚将之提高。输出电压启动斜坡受控于慢启动引脚，还可以配置该引脚来控制排序/跟踪。一个开漏电源正常信号表示输出处于其标称电压的 94% 至 107% 之内。

宽开关频率范围允许对效率及外部组件尺寸进行优化。频率折返和热关断功能在过载情况下保护部件。

器件信息<sup>(1)</sup>

器件型号	封装	封装尺寸 (标称值)
TPS54140A	VSON (10)	3.00mm × 3.00mm
	MSOP (10)	3.00mm × 3.00mm

(1) 要了解所有可用封装，请见数据表末尾的可订购产品附录。

效率与负载电流间的关系

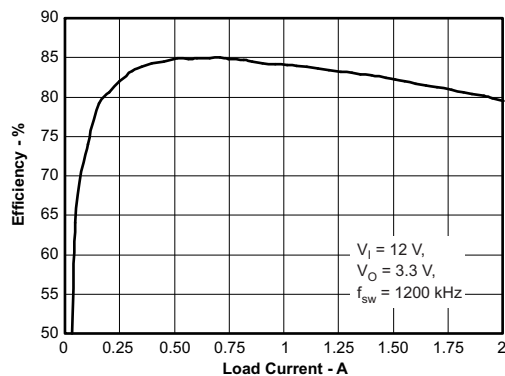

## 目录

<b>1</b>	<b>特性</b> .....	<b>1</b>	<b>8</b>	<b>Application and Implementation</b> .....	<b>18</b>
<b>2</b>	<b>应用范围</b> .....	<b>1</b>	8.1	Application Information .....	18
<b>3</b>	<b>说明</b> .....	<b>1</b>	8.2	Typical Application .....	25
<b>4</b>	<b>修订历史记录</b> .....	<b>2</b>	8.3	System Examples .....	35
<b>5</b>	<b>Pin Configuration and Functions</b> .....	<b>3</b>	<b>9</b>	<b>Power Supply Recommendations</b> .....	<b>39</b>
<b>6</b>	<b>Specifications</b> .....	<b>4</b>	9.1	Sequencing .....	39
6.1	Absolute Maximum Ratings .....	4	<b>10</b>	<b>Layout</b> .....	<b>43</b>
6.2	ESD Ratings .....	4	10.1	Layout Guidelines .....	43
6.3	Recommended Operating Conditions .....	5	10.2	Layout Example .....	43
6.4	Thermal Information .....	5	10.3	Power Dissipation Estimate .....	43
6.5	Electrical Characteristics .....	6	<b>11</b>	<b>器件和文档支持</b> .....	<b>45</b>
6.6	Typical Characteristics .....	8	11.1	器件支持 .....	45
<b>7</b>	<b>Detailed Description</b> .....	<b>12</b>	11.2	社区资源 .....	45
7.1	Overview .....	12	11.3	商标 .....	45
7.2	Functional Block Diagram .....	13	11.4	静电放电警告 .....	45
7.3	Feature Description .....	13	11.5	Glossary .....	45
7.4	Device Functional Modes .....	17	<b>12</b>	<b>机械、封装和可订购信息</b> .....	<b>45</b>

## 4 修订历史记录

注：之前版本的页码可能与当前版本有所不同。

<b>Changes from Revision B (January 2014) to Revision C</b>	<b>Page</b>
• 已添加 ESD 额定值表，功能描述部分，器件功能模式，应用和实施部分，电源相关建议部分，布局部分，器件和文档支持部分以及机械、封装和可订购信息部分。 .....	1

<b>Changes from Revision A (July 2012) to Revision B</b>	<b>Page</b>
• 已删除 数据表标题和特性中的 SWIFT .....	1

<b>Changes from Original (May 2012) to Revision A</b>	<b>Page</b>
• 已更改 说明 部分的文本从“处于其标称电压的 93% 至 107% 之内。”改为：“处于其标称电压的 94% 至 107% 之内。” .....	1
• Changed the values of the Hysteresis current in the Electrical Characteristics table .....	6
• Changed text in the Slow Start and Tracking Pin (SS/TR) section From: "VIN UVLO is exceeded, EN pin pulled below 1.25V" To: "VIN pin is below the VIN UVLO, EN pin pulled below 1.25V" .....	20
• Changed Start Input Voltage (rising VIN) voltage From: 7.25 V To: 7.7 V .....	25
• Changed Start Input Voltage (falling VIN) voltage From: 6.25 V To: 6.7 V .....	25
• Changed Equation 11 .....	26
• Changed 7.25V to 7.7V and 6.25V to 6.7V in the Under Voltage Lock Out Set Point section. ....	30
• Changed Equation 29 .....	31
• Changed Equation 30 and Equation 31 .....	31
• Changed Equation 33 .....	32

## 5 Pin Configuration and Functions

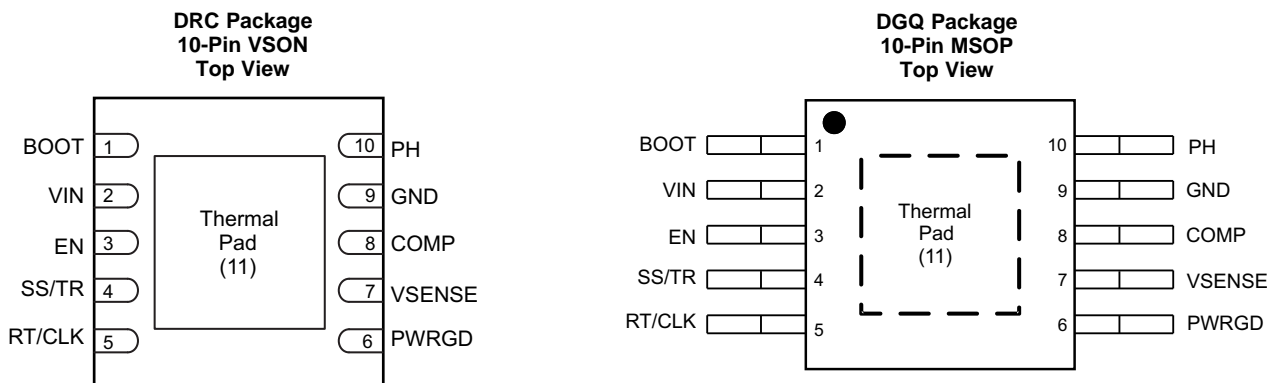

### Pin Functions

PIN		I/O	DESCRIPTION
NAME	NO.		
BOOT	1	O	A bootstrap capacitor is required between BOOT and PH. If the voltage on this capacitor is below the minimum required by the device, the output is forced to switch off until the capacitor is refreshed.
COMP	8	O	Error amplifier output, and input to the output switch current comparator. Connect frequency compensation components to this pin.
EN	3	I	Enable pin, internal pull-up current source. Pull below 1.2V to disable. Float to enable. Adjust the input undervoltage lockout with two resistors.
GND	9	–	Ground
PH	10	O	The source of the internal high-side power MOSFET.
PWRGD	6	O	An open drain output, asserts low if output voltage is low due to thermal shutdown, dropout, over-voltage or EN shut down.
RT/CLK	5	I	Resistor Timing and External Clock. An internal amplifier holds this pin at a fixed voltage when using an external resistor to ground to set the switching frequency. If the pin is pulled above the PLL upper threshold, a mode change occurs and the pin becomes a synchronization input. The internal amplifier is disabled and the pin is a high impedance clock input to the internal PLL. If clocking edges stop, the internal amplifier is re-enabled and the mode returns to a resistor set function.
SS/TR	4	I/O	Slow-start and Tracking. An external capacitor connected to this pin sets the output rise time. Since the voltage on this pin overrides the internal reference, it can be used for tracking and sequencing.
VIN	2	I	Input supply voltage, 3.5 V to 42 V.
VSENSE	7	I	Inverting node of the transconductance ( gm ) error amplifier.
Thermal Pad	11	–	GND pin must be electrically connected to the exposed pad on the printed circuit board for proper operation.

## 6 Specifications

### 6.1 Absolute Maximum Ratings<sup>(1)</sup>

Over operating temperature range (unless otherwise noted).

		MIN	MAX	UNIT
Input voltage	VIN	-0.3	47	V
	EN <sup>(2)</sup>	-0.3	5	
	BOOT		55	
	VSENSE	-0.3	3	
	COMP	-0.3	3	
	PWRGD	-0.3	6	
	SS/TR	-0.3	3	
	RT/CLK	-0.3	3.6	
Output voltage	PH-BOOT		8	V
	PH	-0.6	47	
	PH, 10-ns Transient	-2	47	
Voltage Difference	PAD to GND		±200	mV
Source current	EN		100	µA
	BOOT		100	mA
	VSENSE		10	µA
	PH		Current Limit	A
	RT/CLK		100	µA
Sink current	VIN		Current Limit	A
	COMP		100	µA
	PWRGD		10	mA
	SS/TR		200	µA
Operating junction temperature		-40	150	°C
Storage temperature		-65	150	°C

- (1) Stresses beyond those listed under *absolute maximum ratings* may cause permanent damage to the device. These are stress ratings only and functional operation of the device at these or any other conditions beyond those indicated under *recommended operating conditions* is not implied. Exposure to absolute-maximum-rated conditions for extended periods may affect device reliability.
- (2) See the [Enable and Adjusting Undervoltage Lockout](#) section of this data sheet for details.

### 6.2 ESD Ratings

			VALUE	UNIT
<b>DRC package (VSON)</b>				
V <sub>(ESD)</sub>	Electrostatic discharge	Human-body model (HBM), per ANSI/ESDA/JEDEC JS-001 <sup>(1)</sup>	±2000	V
		Charged-device model (CDM), per JEDEC specification JESD22-C101 <sup>(2)</sup>	±500	
<b>DGQ package (MSOP)</b>				
V <sub>(ESD)</sub>	Electrostatic discharge	Human-body model (HBM), per ANSI/ESDA/JEDEC JS-001 <sup>(1)</sup>	±2000	V
		Charged-device model (CDM), per JEDEC specification JESD22-C101 <sup>(2)</sup>	±500	

- (1) JEDEC document JEP155 states that 500-V HBM allows safe manufacturing with a standard ESD control process. Manufacturing with less than 500-V HBM is possible if necessary precautions are taken.
- (2) JEDEC document JEP157 states that 250-V CDM allows safe manufacturing with a standard ESD control process. Manufacturing with less than 250-V CDM is possible if necessary precautions are taken.

### 6.3 Recommended Operating Conditions

over operating free-air temperature range (unless otherwise noted)

		MIN	MAX	UNIT
$V_{IN}$	Supply input voltage range	3.5	42	V
$V_O$	Output voltage range	0.8	39	V

### 6.4 Thermal Information

THERMAL METRIC <sup>(1)</sup>	TPS54140A		UNIT	
	DGQ (MSOP)	DRC (VSON)		
	10 PINS	10 PINS		
$R_{\theta JA}$	Junction-to-ambient thermal resistance (standard board)	52.3	45.1	°C/W
$R_{\theta JC(top)}$	Junction-to-case (top) thermal resistance	46.3	51.9	°C/W
$R_{\theta JB}$	Junction-to-board thermal resistance	33	20.5	°C/W
$\Psi_{JT}$	Junction-to-top characterization parameter	1.6	0.8	°C/W
$\Psi_{JB}$	Junction-to-board characterization parameter	32.7	20.7	°C/W
$R_{\theta JC(bot)}$	Junction-to-case (bottom) thermal resistance	5.9	5.1	°C/W

- (1) For more information about traditional and new thermal metrics, see the *Semiconductor and IC Package Thermal Metrics* application report, [SPRA953](#).

## 6.5 Electrical Characteristics

 $T_J = -40^{\circ}\text{C}$  to  $150^{\circ}\text{C}$ ,  $V_{IN} = 3.5$  to  $42$  V (unless otherwise noted)

PARAMETER	TEST CONDITIONS	MIN	TYP	MAX	UNIT
<b>SUPPLY VOLTAGE (VIN PIN)</b>					
Operating input voltage		3.5		42	V
Internal undervoltage lockout threshold	No voltage hysteresis, rising and falling		2.5		V
Shutdown supply current	$EN = 0$ V, $25^{\circ}\text{C}$ , $3.5$ V $\leq$ $V_{IN} \leq 42$ V		1.3	4	$\mu\text{A}$
Operating : nonswitching supply current	$V_{SENSE} = 0.83$ V, $V_{IN} = 12$ V, $25^{\circ}\text{C}$		116	136	
<b>ENABLE AND UVLO (EN PIN)</b>					
Enable threshold voltage	No voltage hysteresis, rising and falling	1.11	1.25	1.36	V
Input current	Enable threshold +50 mV		-3.8		$\mu\text{A}$
	Enable threshold -50 mV		-0.9		
Hysteresis current		1.91	2.95	3.99	$\mu\text{A}$
<b>VOLTAGE REFERENCE</b>					
Voltage reference	$T_J = 25^{\circ}\text{C}$	0.792	0.8	0.808	V
		0.784	0.8	0.816	
<b>HIGH-SIDE MOSFET</b>					
On-resistance	$V_{IN} = 3.5$ V, $BOOT-PH = 3$ V		300		$\text{m}\Omega$
	$V_{IN} = 12$ V, $BOOT-PH = 6$ V		200	410	
<b>ERROR AMPLIFIER</b>					
Input current			50		nA
Error amplifier transconductance ( $g_M$ )	$\pm 2 \mu\text{A} < I_{(COMP)} < 2 \mu\text{A}$ , $V_{(COMP)} = 1$ V		97		$\mu\text{S}$
Error amplifier transconductance ( $g_M$ ) during slow start	$\pm 2 \mu\text{A} < I_{(COMP)} < 2 \mu\text{A}$ , $V_{(COMP)} = 1$ V, $V_{SENSE} = 0.4$ V		26		$\mu\text{S}$
Error amplifier dc gain	$V_{SENSE} = 0.8$ V		10000		V/V
Error amplifier bandwidth			2700		kHz
Error amplifier source/sink	$V_{(COMP)} = 1$ V, 100 mV overdrive		$\pm 7$		$\mu\text{A}$
COMP to switch current transconductance			6		A/V
<b>CURRENT LIMIT</b>					
Current limit threshold	$V_{IN} = 12$ V, $T_J = 25^{\circ}\text{C}$	1.8	2.7		A
<b>THERMAL SHUTDOWN</b>					
Thermal shutdown			182		$^{\circ}\text{C}$
<b>TIMING RESISTOR AND EXTERNAL CLOCK (RT/CLK PIN)</b>					
Switching Frequency Range using RT mode		100		2500	kHz
$f_{SW}$ Switching frequency	$R_T = 200$ k $\Omega$	450	581	720	kHz
Switching Frequency Range using CLK mode		300		2200	kHz
Minimum CLK pulse width			40		ns
RT/CLK high threshold			1.9	2.2	V
RT/CLK low threshold		0.5	0.7		V
RT/CLK falling edge to PH rising edge delay	Measured at 500 kHz with RT resistor in series		60		ns
PLL lock in time	Measured at 500 kHz		100		$\mu\text{s}$
<b>SLOW START AND TRACKING (SS/TR)</b>					
Charge current	$V_{SS/TR} = 0.4$ V		2		$\mu\text{A}$
SS/TR-to- $V_{SENSE}$ matching	$V_{SS/TR} = 0.4$ V		45		mV
SS/TR-to-reference crossover	98% nominal		1.0		V

**Electrical Characteristics (continued)**
 $T_J = -40^{\circ}\text{C}$  to  $150^{\circ}\text{C}$ ,  $V_{IN} = 3.5$  to  $42$  V (unless otherwise noted)

PARAMETER		TEST CONDITIONS	MIN	TYP	MAX	UNIT
SS/TR discharge current (overload)		$V_{SENSE} = 0$ V, $V(SS/TR) = 0.4$ V		112		$\mu\text{A}$
SS/TR discharge voltage		$V_{SENSE} = 0$ V		54		mV
<b>POWER GOOD (PWRGD PIN)</b>						
$V_{V_{SENSE}}$	VSENSE threshold	VSENSE falling		92%		
		VSENSE rising		94%		
		VSENSE rising		109%		
		VSENSE falling		107%		
Hysteresis		VSENSE falling		2%		
Output high leakage		$V_{SENSE} = V_{REF}$ , $V_{(PWRGD)} = 5.5$ V, $25^{\circ}\text{C}$		10		nA
On resistance		$I_{(PWRGD)} = 3$ mA, $V_{SENSE} < 0.79$ V		50		$\Omega$
Minimum $V_{IN}$ for defined output		$V_{(PWRGD)} < 0.5$ V, $I_{(PWRGD)} = 100$ $\mu\text{A}$		0.95	1.5	V

## 6.6 Typical Characteristics

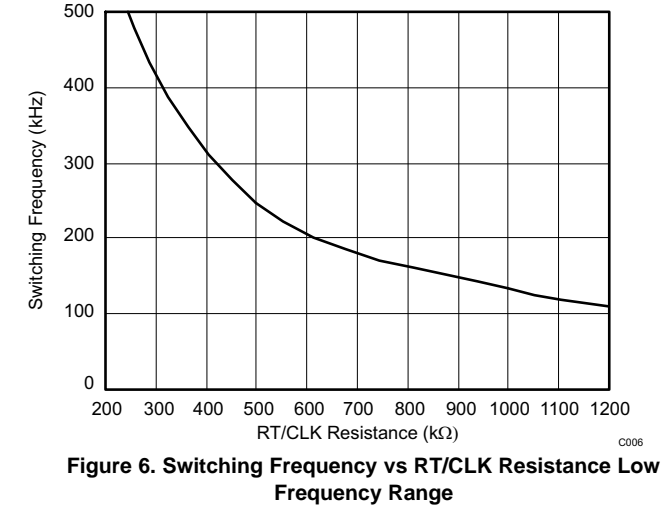
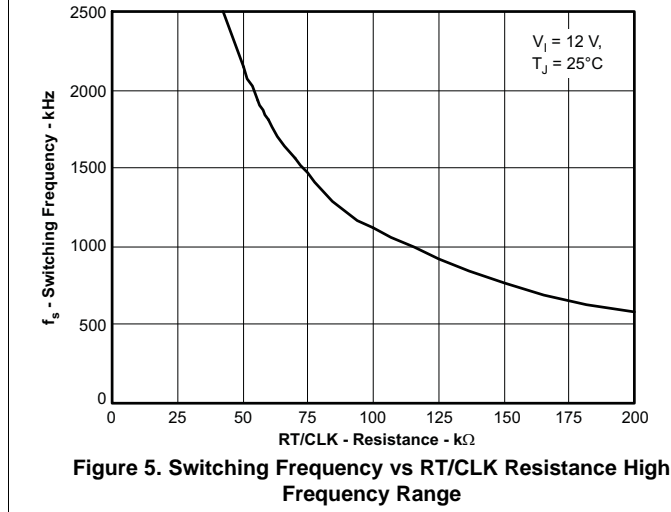
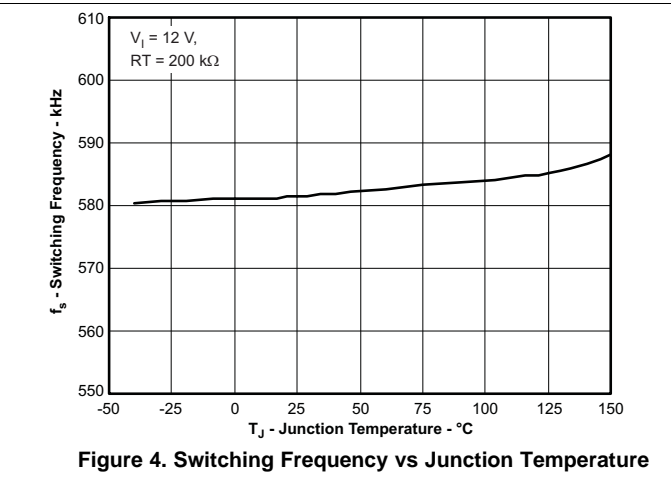
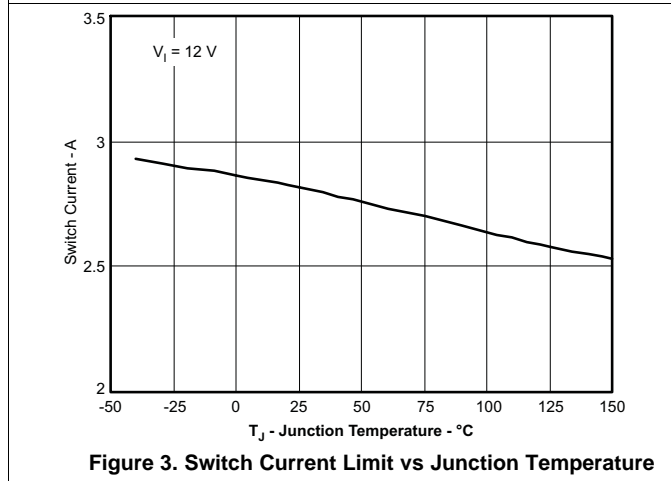
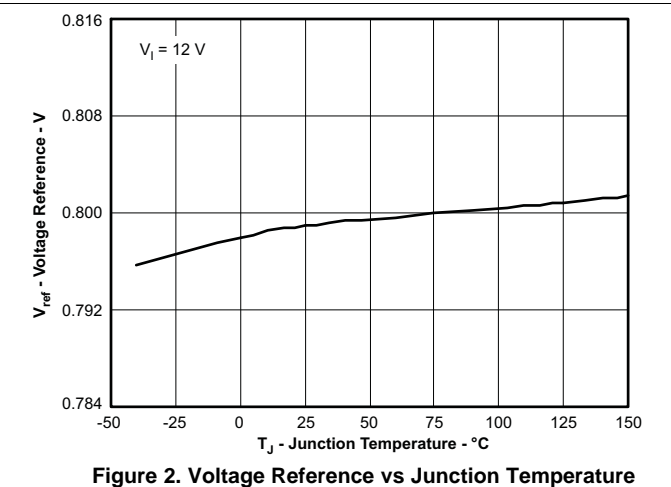
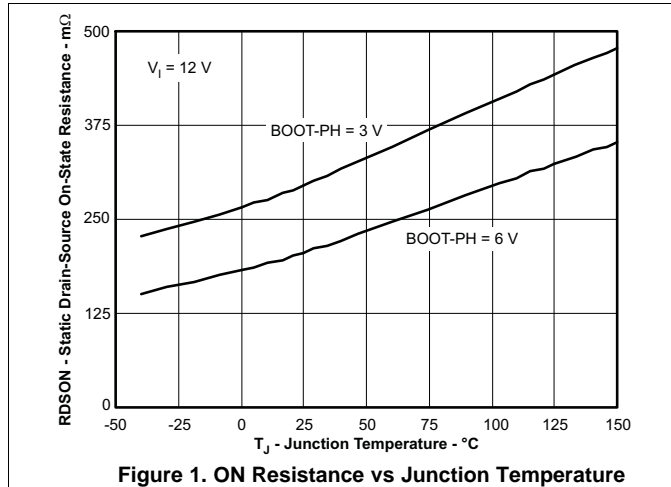

Typical Characteristics (continued)

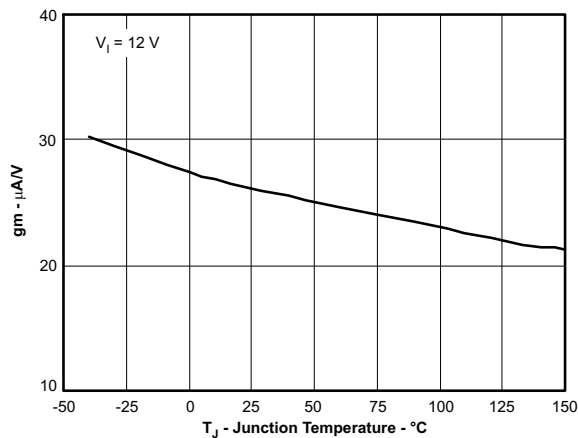

Figure 7. EA Transconductance During Slow Start vs Junction Temperature

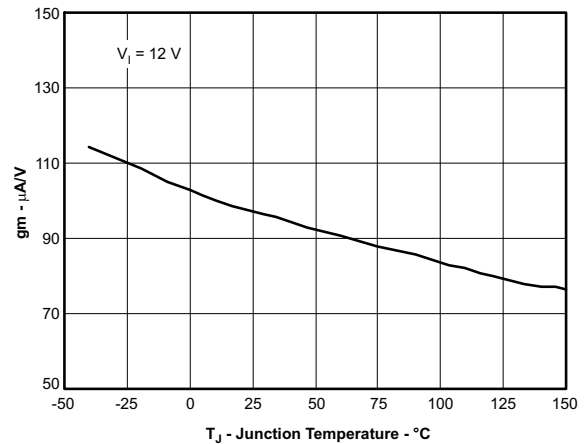

Figure 8. EA Transconductance vs Junction Temperature

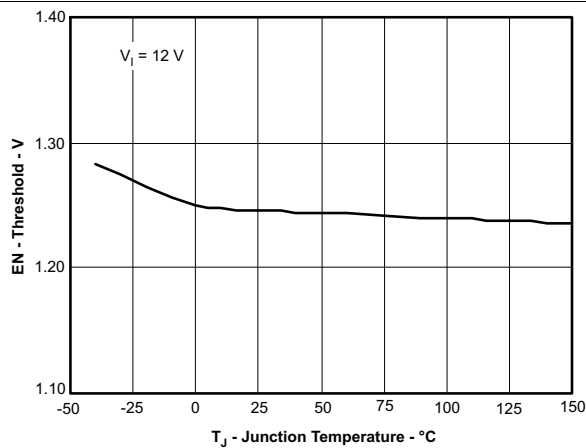

Figure 9. EN Pin Voltage vs Junction Temperature

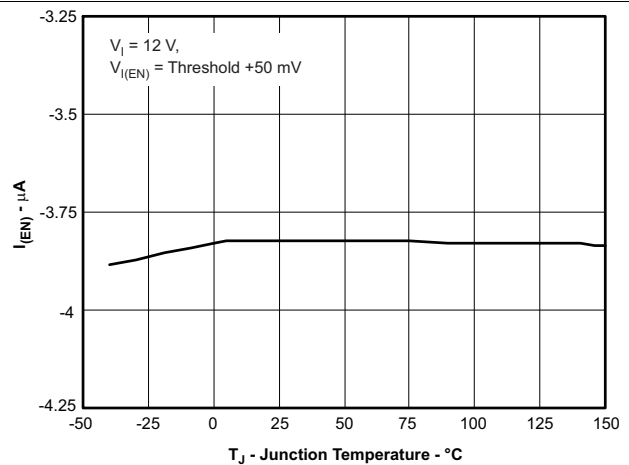

Figure 10. EN Pin Current vs Junction Temperature

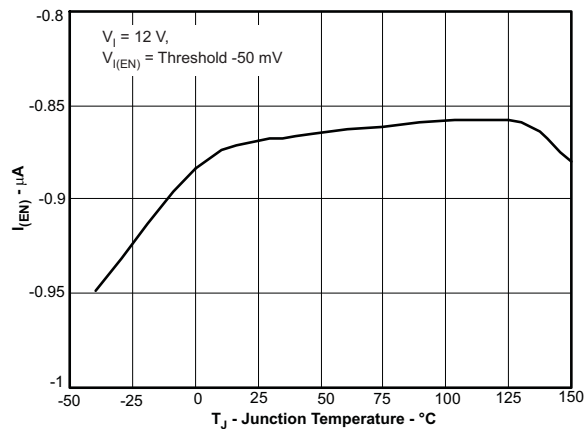

Figure 11. EN Pin Current vs Junction Temperature

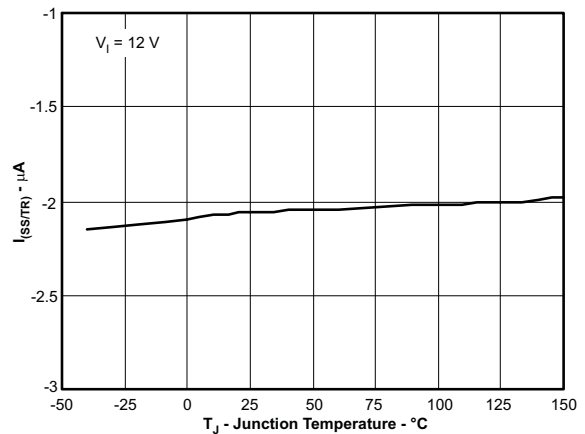

Figure 12. SS/TR Charge Current vs Junction Temperature

Typical Characteristics (continued)

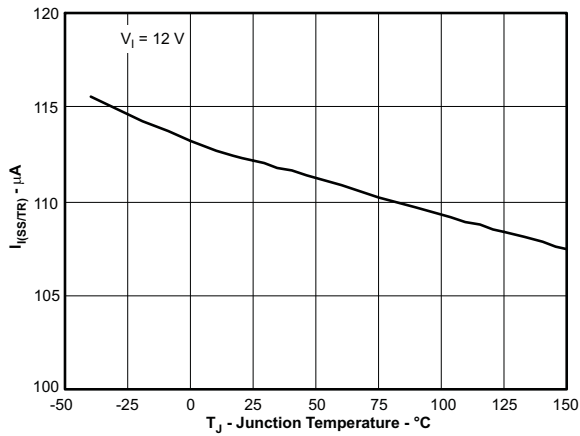

Figure 13. SS/TR Discharge Current vs Junction Temperature

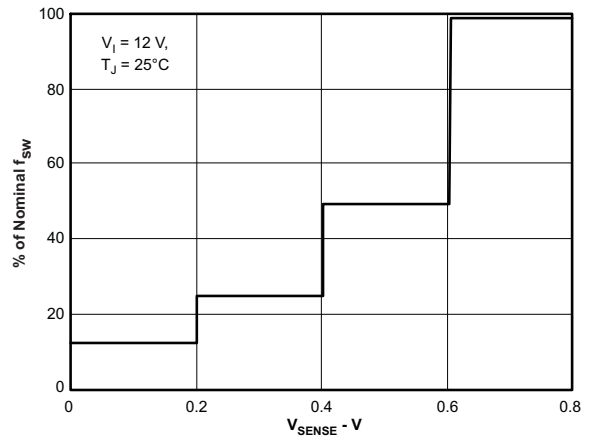

Figure 14. Switching Frequency vs VSENSE

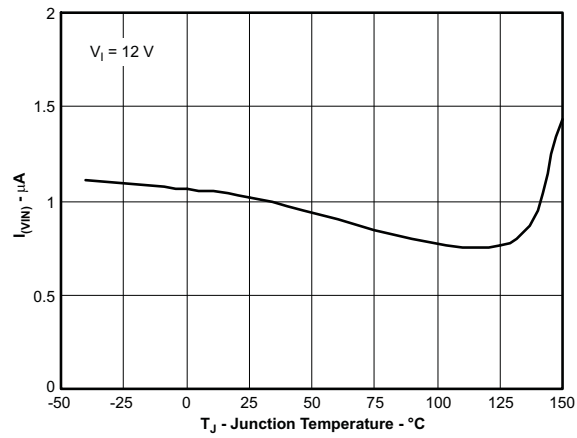

Figure 15. Shutdown Supply Current vs Junction Temperature

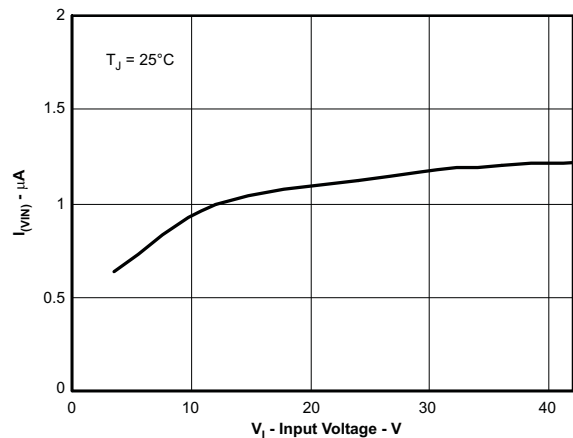

Figure 16. Shutdown Supply Current vs Input Voltage (Vin)

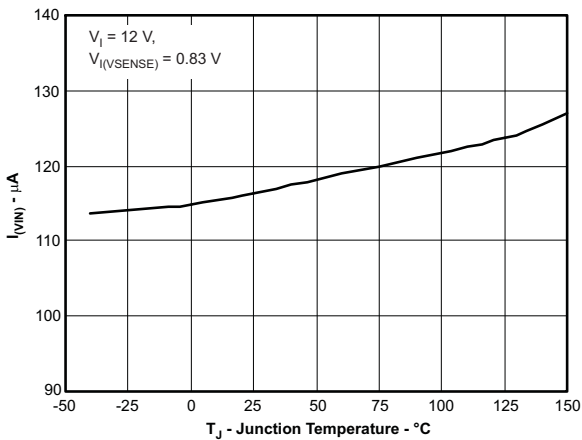

Figure 17. VIN Supply Current vs Junction Temperature

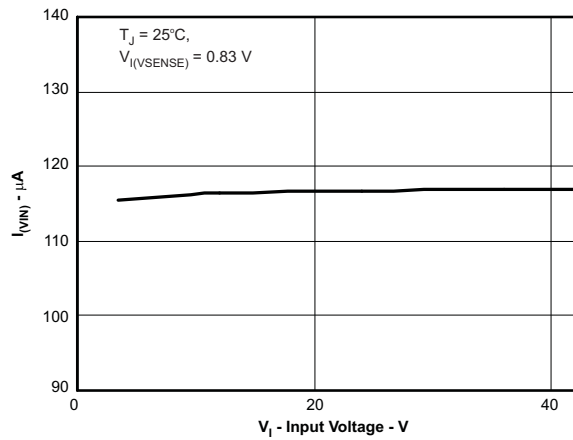

Figure 18. VIN Supply Current vs Input Voltage

Typical Characteristics (continued)

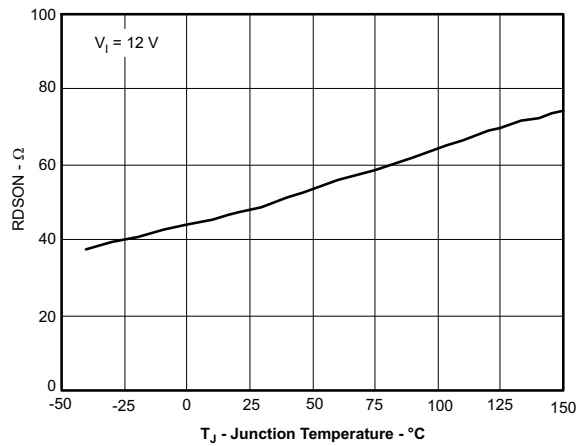

Figure 19. PWRGD ON Resistance vs Junction Temperature

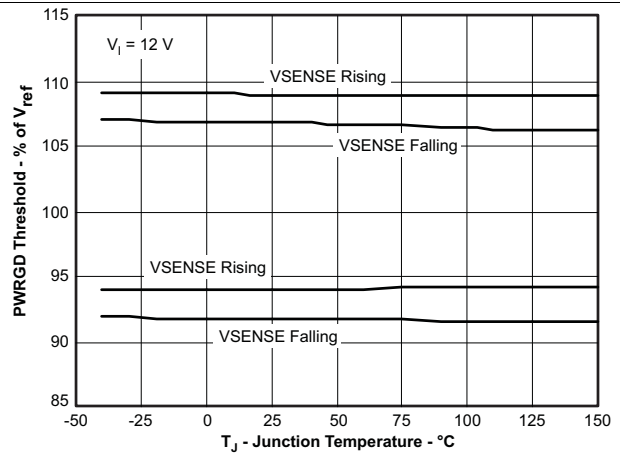

Figure 20. PWRGD Threshold vs Junction Temperature

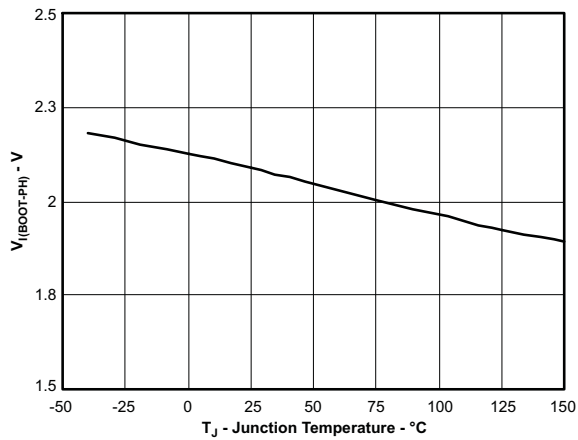

Figure 21. BOOT-PH UVLO vs Junction Temperature

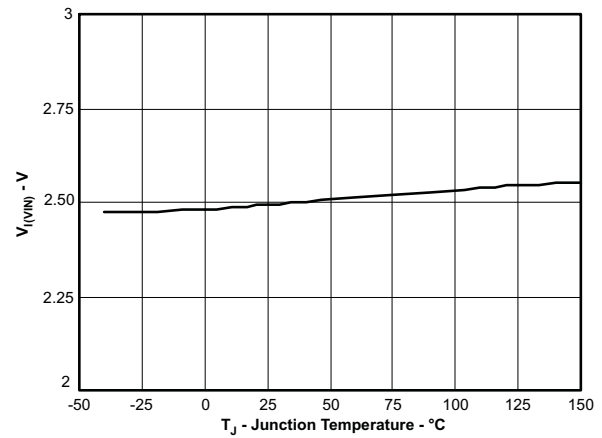

Figure 22. Input Voltage (UVLO) vs Junction Temperature

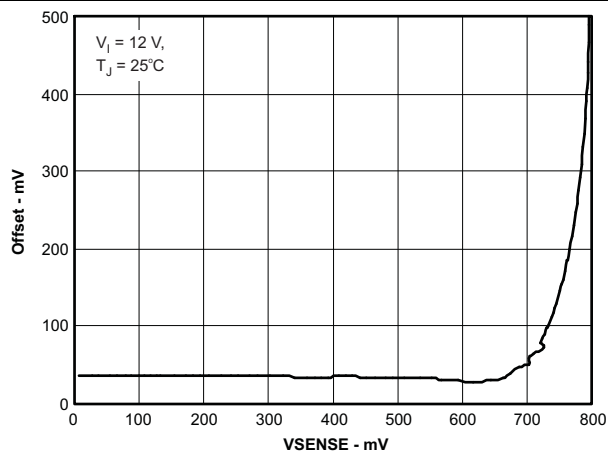

Figure 23. SS/TR to VSENSE Offset vs VSENSE

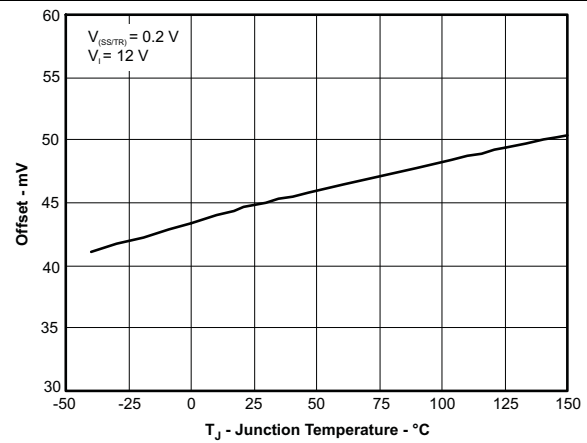

Figure 24. SS/TR to VSENSE Offset vs Temperature

## 7 Detailed Description

### 7.1 Overview

The TPS54140A device is a 42-V, 1.5-A, step-down (buck) regulator with an integrated high side n-channel MOSFET. To improve performance during line and load transients the device implements a constant frequency, current mode control which reduces output capacitance and simplifies external frequency compensation design. The wide switching frequency of 100 kHz to 2500 kHz allows for efficiency and size optimization when selecting the output filter components. The switching frequency is adjusted using a resistor to ground on the RT/CLK pin. The device has an internal phase lock loop (PLL) on the RT/CLK pin that is used to synchronize the power switch turn on to a falling edge of an external system clock.

The TPS54140A has a default start up voltage of approximately 2.5 V. The EN pin has an internal pull-up current source that can be used to adjust the input voltage under voltage lockout (UVLO) threshold with two external resistors. In addition, the pull up current provides a default condition. When the EN pin is floating the device will operate. The operating current is 116  $\mu$ A when not switching and under no load. When the device is disabled, the supply current is 1.3  $\mu$ A.

The integrated 200 m $\Omega$  high side MOSFET allows for high efficiency power supply designs capable of delivering 1.5 amperes of continuous current to a load. The TPS54140A reduces the external component count by integrating the boot recharge diode. The bias voltage for the integrated high side MOSFET is supplied by a capacitor on the BOOT to PH pin. The boot capacitor voltage is monitored by an UVLO circuit and will turn the high side MOSFET off when the boot voltage falls below a preset threshold. The TPS54140A can operate at high duty cycles because of the boot UVLO. The output voltage can be stepped down to as low as the 0.8 V reference.

The TPS54140A has a power good comparator (PWRGD) which asserts when the regulated output voltage is less than 92% or greater than 109% of the nominal output voltage. The PWRGD pin is an open drain output which deasserts when the VSENSE pin voltage is between 94% and 107% of the nominal output voltage allowing the pin to transition high when a pull-up resistor is used.

The TPS54140A minimizes excessive output overvoltage (OV) transients by taking advantage of the OV power good comparator. When the OV comparator is activated, the high side MOSFET is turned off and masked from turning on until the output voltage is lower than 107%.

The SS/TR (slow start and tracking) pin is used to minimize inrush currents or provide power supply sequencing during power up. A small value capacitor should be coupled to the pin to adjust the slow start time. A resistor divider can be coupled to the pin for critical power supply sequencing requirements. The SS/TR pin is discharged before the output powers up. This discharging ensures a repeatable restart after an over-temperature fault, UVLO fault or a disabled condition.

The TPS54140A, also, discharges the slow start capacitor during overload conditions with an overload recovery circuit. The overload recovery circuit will slow start the output from the fault voltage to the nominal regulation voltage once a fault condition is removed. A frequency foldback circuit reduces the switching frequency during startup and overcurrent fault conditions to help control the inductor current.

## 7.2 Functional Block Diagram

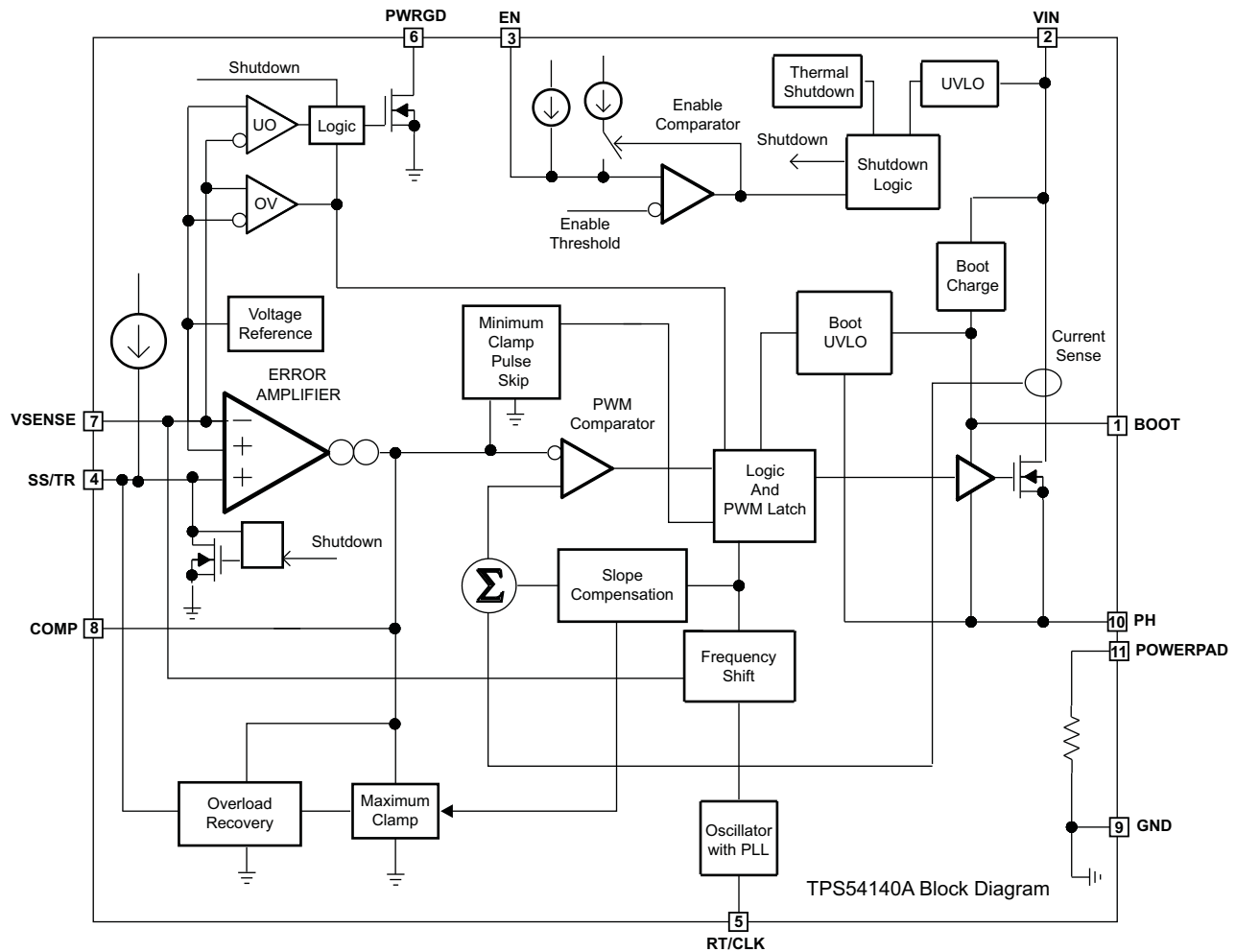

## 7.3 Feature Description

### 7.3.1 Fixed Frequency PWM Control

The TPS54140A uses an adjustable fixed frequency, peak current mode control. The output voltage is compared through external resistors on the VSENSE pin to an internal voltage reference by an error amplifier which drives the COMP pin. An internal oscillator initiates the turn on of the high side power switch. The error amplifier output is compared to the high side power switch current. When the power switch current reaches the COMP voltage level the power switch is turned off. The COMP pin voltage will increase and decrease as the output current increases and decreases. The device implements a current limit by clamping the COMP pin voltage to a maximum level. The Eco-mode™ is implemented with a minimum clamp on the COMP pin.

### 7.3.2 Slope Compensation Output Current

The TPS54140A adds a compensating ramp to the switch current signal. This slope compensation prevents sub-harmonic oscillations. The available peak inductor current remains constant over the full duty cycle range.

### 7.3.3 Pulse Skip Eco-mode

The TPS54140A enters the pulse skip mode when the voltage on the COMP pin is the minimum clamp value. The TPS54140A operates in a pulse skip mode at light load currents to improve efficiency. The peak switch current during the pulse skip mode will be the greater value of 50mA or the peak inductor current that is a function of the minimum on time, input voltage, output voltage and inductance value. When the load current is low and the output voltage is within regulation the device will enter a sleep mode and draw only 116  $\mu$ A input

## Feature Description (continued)

quiescent current. While the device is in sleep mode the output power is delivered by the output capacitor. As the load current decreases, the time the output capacitor supplies the load current increases and the switching frequency decreases reducing gate drive and switching losses. As the output voltage drops, the TPS54140A wakes up from the sleep mode and the power switch turns on to recharge the output capacitor, see [Figure 25](#). The internal PLL remains operating when in sleep mode. When operating at light load currents in the pulse skip mode the switching transitions occur synchronously with the external clock signal.

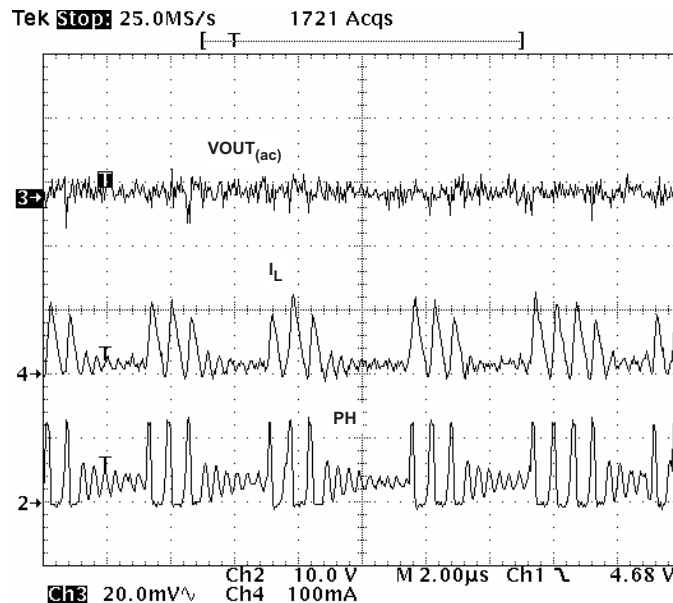

**Figure 25. Pulse Skip Mode Operation**

### 7.3.4 Bootstrap Voltage (BOOT)

The TPS54140A has an integrated boot regulator and requires a small ceramic capacitor between the BOOT and PH pin to provide the gate drive voltage for the high side MOSFET. The value of the ceramic capacitor should be 0.1  $\mu\text{F}$ . A ceramic capacitor with an X7R or X5R grade dielectric is recommended because of the stable characteristics over temperature and voltage. To improve drop out, the TPS54140A is designed to operate at 100% duty cycle as long as the BOOT to PH pin voltage is greater than 2.1 V. When the voltage from BOOT to PH drops below 2.1 V, the high side MOSFET is turned off using an UVLO circuit allowing for the low side diode to conduct which allows refreshing of the BOOT capacitor. Since the supply current sourced from the BOOT capacitor is low, the high side MOSFET can remain on for more switching cycles than it refreshes, thus, the effective duty cycle limitation that is attributed to the boot regulator system is high.

### 7.3.5 Low Dropout Operation

The duty cycle during dropout of the regulator will be mainly determined by the voltage drops across the power MOSFET, inductor, low side diode and printed circuit board resistance. During operating conditions in which the input voltage drops, the high side MOSFET can remain on for 100% of the duty cycle to maintain output regulation or until the BOOT to PH voltage falls below 2.1 V.

Once the high side is off, the low side diode will conduct and the BOOT capacitor will be recharged. During this boot capacitor recharge time, the inductor current will ramp down until the high side MOSFET turns on. The recharge time is longer than the typical high side off time of previous switching cycles, and thus, the inductor current ripple is larger resulting in more ripple voltage on the output. The recharge time is a function of the input voltage, boot capacitor value, and the impedance of the internal boot recharge diode.

## Feature Description (continued)

Attention needs to be taken in maximum duty cycle applications which experience extended time periods without a load current. When the voltage across the BOOT capacitors falls below the 2.1-V threshold in applications that have a difference in the input voltage and output voltage that is less than 3 V, the high side MOSFET will be turned off but there is not enough current in the inductor to pull the PH pin down to recharge the boot capacitor. The regulator will not switch because the boot capacitor is less than 2.1 V and the output capacitor will decay until the difference in the input voltage and output voltage is 2.1 V. At this time the boot under voltage lockout is exceeded and the device will switch until the desired output voltage is reached.

The start and stop voltages are shown in Figure 26 and Figure 27 for 3.3-V and 5-V applications. The voltages are plotted versus the load current. The start voltage is defined as the input voltage needed to regulate within 1%. The stop voltage is defined as the input voltage at which the output drops by 5% or stops switching.

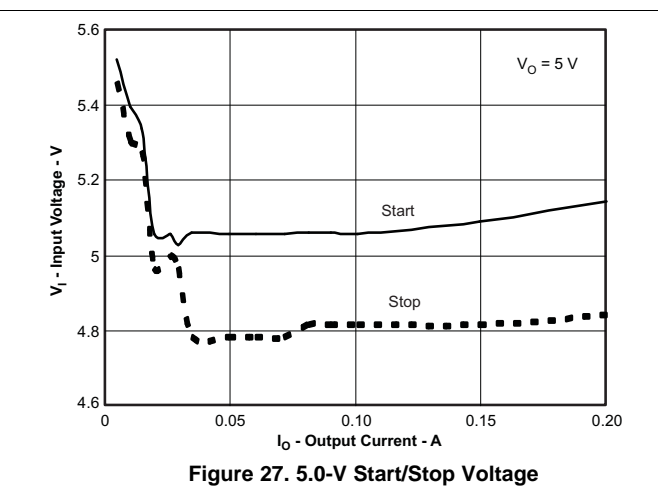
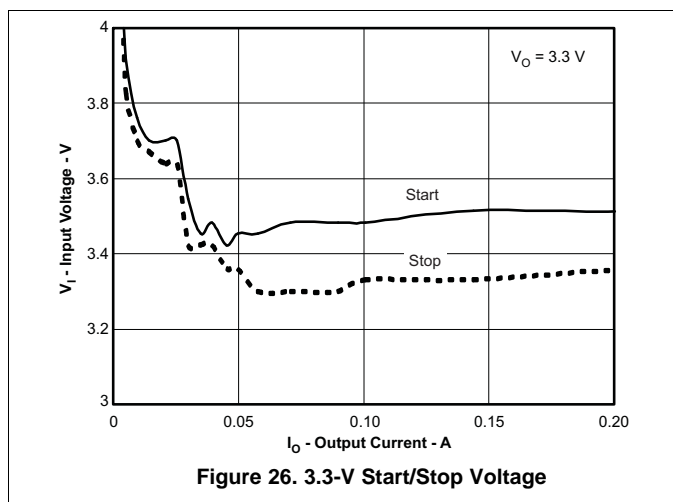

### 7.3.6 Error Amplifier

The TPS54140A has a transconductance amplifier for the error amplifier. The error amplifier compares the VSENSE voltage to the lower of the SS/TR pin voltage or the internal 0.8 V voltage reference. The transconductance (gm) of the error amplifier is 97  $\mu\text{A/V}$  during normal operation. During the slow start operation, the transconductance is a fraction of the normal operating gm. When the voltage of the VSENSE pin is below 0.8 V and the device is regulating using the SS/TR voltage, the gm is 25  $\mu\text{A/V}$ .

The frequency compensation components (capacitor, series resistor and capacitor) are added to the COMP pin to ground.

### 7.3.7 Voltage Reference

The voltage reference system produces a precise  $\pm 2\%$  voltage reference over temperature by scaling the output of a temperature stable bandgap circuit.

### 7.3.8 Overload Recovery Circuit

The TPS54140A has an overload recovery (OLR) circuit. The OLR circuit will slow start the output from the overload voltage to the nominal regulation voltage once the fault condition is removed. The OLR circuit will discharge the SS/TR pin to a voltage slightly greater than the VSENSE pin voltage using an internal pull down of 100  $\mu\text{A}$  when the error amplifier is changed to a high voltage from a fault condition. When the fault condition is removed, the output will slow start from the fault voltage to nominal output voltage.

## Feature Description (continued)

### 7.3.9 Overcurrent Protection and Frequency Shift

The TPS54140A implements current mode control which uses the COMP pin voltage to turn off the high side MOSFET on a cycle by cycle basis. Each cycle the switch current and COMP pin voltage are compared, when the peak switch current intersects the COMP voltage, the high side switch is turned off. During overcurrent conditions that pull the output voltage low, the error amplifier will respond by driving the COMP pin high, increasing the switch current. The error amplifier output is clamped internally, which functions as a switch current limit.

To increase the maximum operating switching frequency at high input voltages the TPS54140A implements a frequency shift. The switching frequency is divided by 8, 4, 2, and 1 as the voltage ramps from 0 to 0.8 volts on VSENSE pin.

The device implements a digital frequency shift to enable synchronizing to an external clock during normal startup and fault conditions. Since the device can only divide the switching frequency by 8, there is a maximum input voltage limit in which the device operates and still have frequency shift protection.

During short-circuit events (particularly with high input voltage applications), the control loop has a finite minimum controllable on time and the output has a very low voltage. During the switch on time, the inductor current ramps to the peak current limit because of the high input voltage and minimum on time. During the switch off time, the inductor would normally not have enough off time and output voltage for the inductor to ramp down by the ramp up amount. The frequency shift effectively increases the off time allowing the current to ramp down.

### 7.3.10 Power Good (PWRGD Pin)

The PWRGD pin is an open drain output. Once the VSENSE pin is between 94% and 107% of the internal voltage reference the PWRGD pin is de-asserted and the pin floats. It is recommended to use a pullup resistor between the values of 10 and 100k $\Omega$  to a voltage source that is 5.5 V or less. The PWRGD is in a defined state once the VIN input voltage is greater than 1.5 V but with reduced current sinking capability. The PWRGD will achieve full current sinking capability as VIN input voltage approaches 3 V.

The PWRGD pin is pulled low when the VSENSE is lower than 92% or greater than 109% of the nominal internal reference voltage. Also, the PWRGD is pulled low, if the UVLO or thermal shutdown are asserted or the EN pin pulled low.

### 7.3.11 Overvoltage Transient Protection

The TPS54140A incorporates an overvoltage transient protection (OVTP) circuit to minimize voltage overshoot when recovering from output fault conditions or strong unload transients on power supply designs with low value output capacitance. For example, when the power supply output is overloaded the error amplifier compares the actual output voltage to the internal reference voltage. If the VSENSE pin voltage is lower than the internal reference voltage for a considerable time, the output of the error amplifier will respond by clamping the error amplifier output to a high voltage. Thus, requesting the maximum output current. Once the condition is removed, the regulator output rises and the error amplifier output transitions to the steady state duty cycle. In some applications, the power supply output voltage can respond faster than the error amplifier output can respond, this actuality leads to the possibility of an output overshoot. The OVTP feature minimizes the output overshoot, when using a low value output capacitor, by implementing a circuit to compare the VSENSE pin voltage to OVTP threshold which is 109% of the internal voltage reference. If the VSENSE pin voltage is greater than the OVTP threshold, the high side MOSFET is disabled preventing current from flowing to the output and minimizing output overshoot. When the VSENSE voltage drops lower than the OVTP threshold, the high side MOSFET is allowed to turn on at the next clock cycle.

### 7.3.12 Thermal Shutdown

The device implements an internal thermal shutdown to protect itself if the junction temperature exceeds 182°C. The thermal shutdown forces the device to stop switching when the junction temperature exceeds the thermal trip threshold. Once the die temperature decreases below 182°C, the device reinitiates the power up sequence by discharging the SS/TR pin.

## 7.4 Device Functional Modes

### 7.4.1 Operation with $V_{IN} < 3.5\text{ V}$ (Minimum $V_{IN}$ )

The device is recommended to operate with input voltages above 3.5 V. The typical  $V_{IN}$  UVLO threshold is 2.5 V and the device may operate at input voltages down to the UVLO voltage. At input voltages below the actual UVLO voltage, the device will not switch. The PWRGD output will be controlled once  $V_{IN}$  is above 1.5 V maximum. If EN is externally pulled up to  $V_{IN}$  or left floating, when  $V_{IN}$  passes the UVLO threshold the device will become active. Switching is enabled the soft start sequence is initiated. The TPS54140 will start at the soft start time determined by the external soft start capacitor at the SS/TR pin.

### 7.4.2 Operation with EN Control

The enable threshold voltage is 1.25 V typical. With EN held below that voltage the device is disabled and switching is inhibited even if  $V_{IN}$  is above its UVLO threshold. The IC quiescent current is reduced in this state. If the EN voltage is increased above the threshold while  $V_{IN}$  is above its UVLO threshold, the device becomes active. Switching is enabled, and the soft start sequence is initiated. The TPS54140 will start at the soft start time determined by the external slow start capacitor at the SS/TR pin.

## 8 Application and Implementation

### NOTE

Information in the following applications sections is not part of the TI component specification, and TI does not warrant its accuracy or completeness. TI's customers are responsible for determining suitability of components for their purposes. Customers should validate and test their design implementation to confirm system functionality.

### 8.1 Application Information

The TPS54140A is a 42-V, 1.5-A, step-down regulator with an integrated high-side MOSFET. This device is typically used to convert a higher DC voltage to a lower DC voltage with a maximum available output current of 1.5 A. Example applications are 12-V, 24-V and 48-V Industrial, Automotive and Commercial power systems. Use the following design procedure to select component values for the TPS54140A. This procedure illustrates the design of a high-frequency switching regulator. The Excel® spreadsheet ([SLVC432](#)) located on the product page can help on all calculations. Alternatively, use the WEBENCH software to generate a complete design. The WEBENCH software uses an iterative design procedure and accesses a comprehensive database of components when generating a design.

#### 8.1.1 Adjusting the Output Voltage

The output voltage is set with a resistor divider from the output node to the VSENSE pin. It is recommended to use 1% tolerance or better divider resistors. Start with a 10 kΩ for the R2 resistor and use the [Equation 1](#) to calculate R1. To improve efficiency at light loads consider using larger value resistors. If the values are too high the regulator will be more susceptible to noise and voltage errors from the VSENSE input current will be noticeable

$$R1 = R2 \times \left( \frac{V_{OUT} - 0.8V}{0.8V} \right) \quad (1)$$

#### 8.1.2 Enable and Adjusting Undervoltage Lockout

The TPS54140A is disabled when the VIN pin voltage falls below 2.5 V. If an application requires a higher undervoltage lockout (UVLO), use the EN pin as shown in [Figure 28](#) to adjust the input voltage UVLO by using the two external resistors. Though it is not necessary to use the UVLO adjust registers, for operation providing a consistent power up behavior is recommended. The EN pin has an internal pull-up current source, I1, of 0.9 μA that provides the default condition of the TPS54140A operating when the EN pin floats. Once the EN pin voltage exceeds 1.25 V, an additional 2.9 μA of hysteresis, Ihys, is added. This additional current facilitates input voltage hysteresis. Use [Equation 2](#) to set the external hysteresis for the input voltage. Use [Equation 3](#) to set the input start voltage.

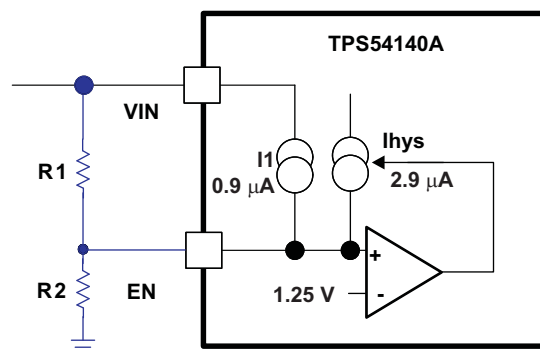

**Figure 28. Adjustable Undervoltage Lockout (UVLO)**

$$R1 = \frac{V_{START} - V_{STOP}}{I_{HYS}} \quad (2)$$

Application Information (continued)

$$R2 = \frac{V_{ENA}}{\frac{V_{START} - V_{ENA}}{R1} + I_1} \tag{3}$$

Another technique to add input voltage hysteresis is shown in [Figure 29](#). This method may be used, if the resistance values are high from the previous method and a wider voltage hysteresis is needed. The resistor R3 sources additional hysteresis current into the EN pin.

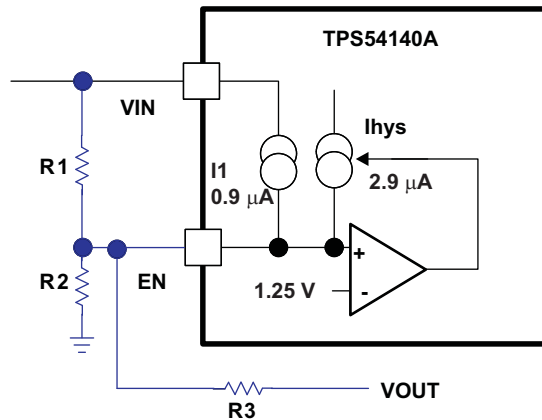
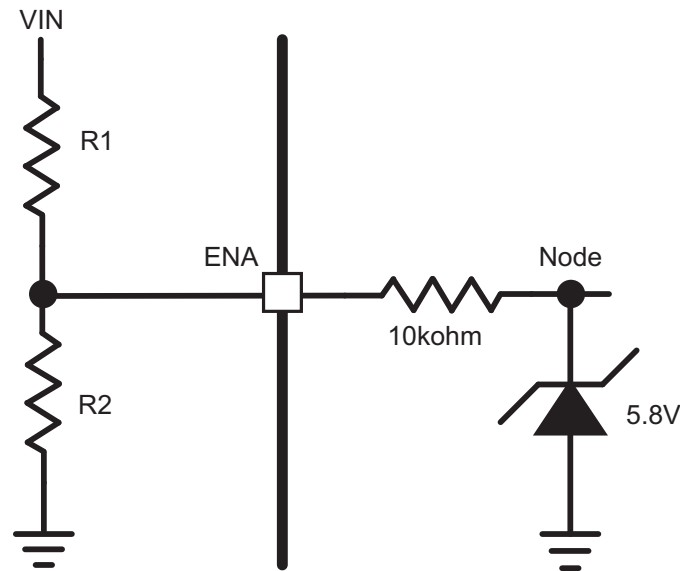

Figure 29. Adding Additional Hysteresis

$$R1 = \frac{V_{START} - V_{STOP}}{I_{HYS} + \frac{V_{OUT}}{R3}} \tag{4}$$

$$R2 = \frac{V_{ENA}}{\frac{V_{START} - V_{ENA}}{R1} + I_1 - \frac{V_{ENA}}{R3}} \tag{5}$$

Do not place a low-impedance voltage source with greater than 5 V directly on the EN pin. Do not place a capacitor directly on the EN pin if  $V_{EN} > 5$  V when using a voltage divider to adjust the start and stop voltage. The node voltage, (see [Figure 30](#)) must remain equal to or less than 5.8 V. The zener diode can sink up to 100 μA. The EN pin voltage can be greater than 5 V if the  $V_{IN}$  voltage source has a high impedance and does not source more than 100 μA into the EN pin.

**Application Information (continued)**

**Figure 30. Node Voltage**
**8.1.3 Slow Start/Tracking Pin (SS/TR)**

The TPS54140A effectively uses the lower voltage of the internal voltage reference or the SS/TR pin voltage as the power-supply's reference voltage and regulates the output accordingly. A capacitor on the SS/TR pin to ground implements a slow start time. The TPS54140A has an internal pull-up current source of 2  $\mu\text{A}$  that charges the external slow start capacitor. The calculations for the slow start time (10% to 90%) are shown in [Equation 6](#). The voltage reference ( $V_{\text{REF}}$ ) is 0.8 V and the slow start current ( $I_{\text{SS}}$ ) is 2  $\mu\text{A}$ . The slow start capacitor should remain lower than 0.47  $\mu\text{F}$  and greater than 0.4 nF.

$$C_{\text{SS}} (\text{nF}) = \frac{t_{\text{SS}} (\text{ms}) \times I_{\text{SS}} (\mu\text{A})}{V_{\text{REF}} (\text{V}) \times 0.8} \quad (6)$$

At power up, the TPS54140A will not start switching until the slow start pin is discharged to less than 40 mV to ensure a proper power up, see [Figure 31](#).

Also, during normal operation, the TPS54140A stops switching and the SS/TR must be discharged to 40 mV when the voltage at the VIN pin is below the VIN UVLO, EN pin pulled below 1.25 V, or a thermal shutdown event occurs.

The VSENSE voltage will follow the SS/TR pin voltage with a 45-mV offset up to 85% of the internal voltage reference. When the SS/TR voltage is greater than 85% on the internal reference voltage the offset increases as the effective system reference transitions from the SS/TR voltage to the internal voltage reference (see [Figure 23](#)). The SS/TR voltage will ramp linearly until clamped at 1.7 V.

Application Information (continued)

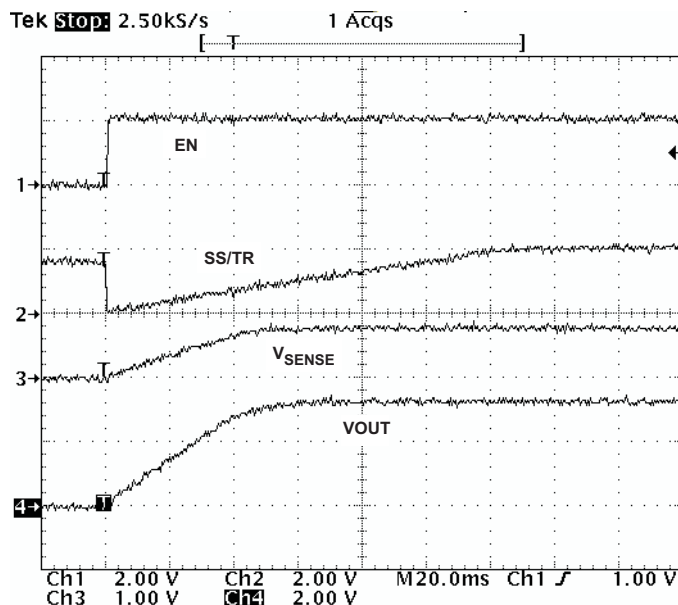

Figure 31. Operation of SS/TR Pin when Starting

8.1.4 Constant Switching Frequency and Timing Resistor (RT/CLK Pin)

The switching frequency of the TPS54140A is adjustable over a wide range from approximately 100 kHz to 2500 kHz by placing a resistor on the RT/CLK pin. The RT/CLK pin voltage is typically 0.5 V and must have a resistor to ground to set the switching frequency. To determine the timing resistance for a given switching frequency, use Equation 7 or the curves in Figure 32 or Figure 33. To reduce the solution size one would typically set the switching frequency as high as possible, but tradeoffs of the supply efficiency, maximum input voltage and minimum controllable on time should be considered.

The minimum controllable on time is typically 130 ns and limits the maximum operating input voltage.

The maximum switching frequency is also limited by the frequency shift circuit. More discussion on the details of the maximum switching frequency is located below.

$$R_{RT} (k\Omega) = \frac{206033}{f_{SW} (kHz)^{1.0888}} \tag{7}$$

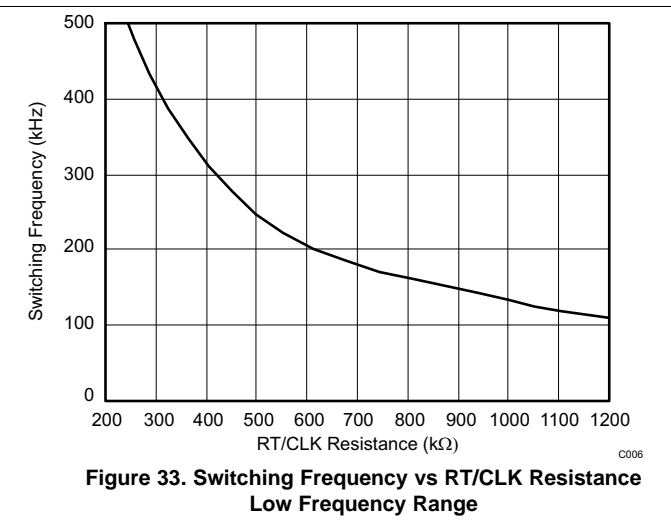
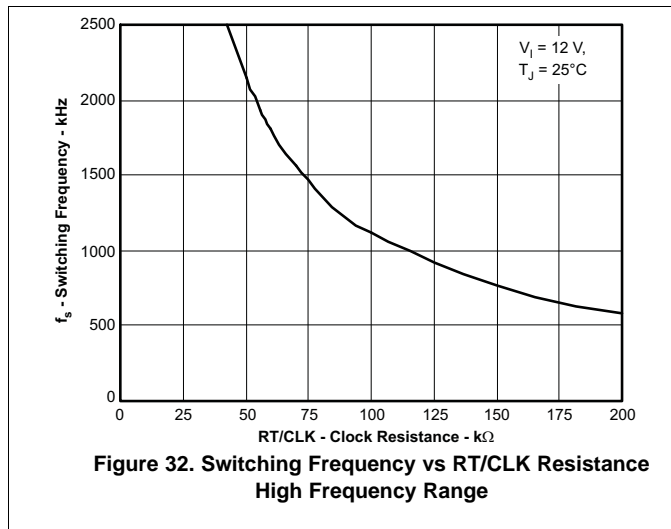
**Application Information (continued)**

**8.1.5 Selecting the Switching Frequency**

The switching frequency that is selected should be the lower value of the two equations, [Equation 8](#) and [Equation 9](#). [Equation 8](#) is the maximum switching frequency limitation set by the minimum controllable on time. Setting the switching frequency above this value will cause the regulator to skip switching pulses.

[Equation 9](#) is the maximum switching frequency limit set by the frequency shift protection. To have adequate output short circuit protection at high input voltages, the switching frequency should be set to be less than the  $f_{sw(maxshift)}$  frequency. In [Equation 9](#), to calculate the maximum switching frequency one must take into account that the output voltage decreases from the nominal voltage to 0 volts, the  $f_{div}$  integer increases from 1 to 8 corresponding to the frequency shift.

In [Figure 34](#), the solid line illustrates a typical safe operating area regarding frequency shift and assumes the output voltage is zero volts, and the resistance of the inductor is  $0.1 \Omega$ , FET on resistance of  $0.2 \Omega$  and the diode voltage drop is  $0.5 \text{ V}$ . The dashed line is the maximum switching frequency to avoid pulse skipping. Enter these equations in a spreadsheet or other software or use the SwitcherPro design software to determine the switching frequency.

$$f_{SW(maxskip)} = \frac{1}{t_{ON}} \times \left( \frac{I_L \times R_{dc} + V_{OUT} + V_d}{V_{IN} - I_L \times R_{DS(on)} + V_d} \right) \quad (8)$$

$$f_{SWshift} = \frac{f_{DIV}}{t_{ON}} \times \left( \frac{I_L \times R_{dc} + V_{OUT(sc)} + V_d}{V_{IN} - I_L \times R_{DS(on)} + V_d} \right) \quad (9)$$

$I_L$	inductor current
$R_{dc}$	inductor resistance
$V_{IN}$	maximum input voltage
$V_{OUT}$	output voltage
$V_{OUTSC}$	output voltage during short
$V_c$	diode voltage drop
$R_{DS(on)}$	switch on resistance
$t_{ON(min)}$	minimum controllable on time
$f_{DIV}$	frequency divide equals (1, 2, 4, or 8)

## Application Information (continued)

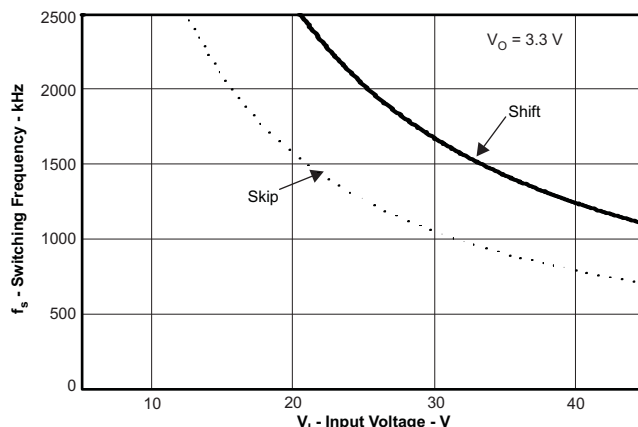

Figure 34. Maximum Switching Frequency vs. Input Voltage

### 8.1.6 How to Interface to RT/CLK Pin

The RT/CLK pin can be used to synchronize the regulator to an external system clock. To implement the synchronization feature connect a square wave to the RT/CLK pin through the circuit network shown in Figure 35. The square wave amplitude must transition lower than 0.5 V and higher than 2.2 V on the RT/CLK pin and have an on time greater than 40 ns and an off time greater than 40 ns. The synchronization frequency range is 300 kHz to 2200 kHz. The rising edge of the PH will be synchronized to the falling edge of RT/CLK pin signal. The external synchronization circuit should be designed in such a way that the device will have the default frequency set resistor connected from the RT/CLK pin to ground should the synchronization signal turn off. It is recommended to use a frequency set resistor connected as shown in Figure 35 through a 50Ω resistor to ground. The resistor should set the switching frequency close to the external CLK frequency. It is recommended to ac couple the synchronization signal through a 10 pF ceramic capacitor to RT/CLK pin and a 4kΩ series resistor. The series resistor reduces PH jitter in heavy load applications when synchronizing to an external clock and in applications which transition from synchronizing to RT mode. The first time the CLK is pulled above the CLK threshold the device switches from the RT resistor frequency to PLL mode. The internal 0.5V voltage source is removed and the CLK pin becomes high impedance as the PLL starts to lock onto the external signal. Since there is a PLL on the regulator the switching frequency can be higher or lower than the frequency set with the external resistor. The device transitions from the resistor mode to the PLL mode and then will increase or decrease the switching frequency until the PLL locks onto the CLK frequency within 100 microseconds.

When the device transitions from the PLL to resistor mode the switching frequency will slow down from the CLK frequency to 150 kHz, then reapply the 0.5 V voltage and the resistor will then set the switching frequency. The switching frequency is divided by 8, 4, 2, and 1 as the voltage ramps from 0 to 0.8 volts on VSENSE pin. The device implements a digital frequency shift to enable synchronizing to an external clock during normal startup and fault conditions. Figure 36, Figure 37 and Figure 38 show the device synchronized to an external system clock in continuous conduction mode (ccm) discontinuous conduction (dcm) and pulse skip mode (psm).

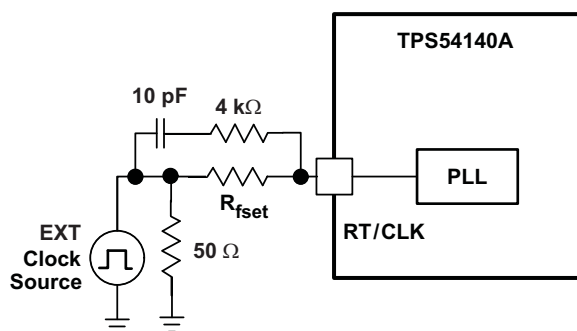
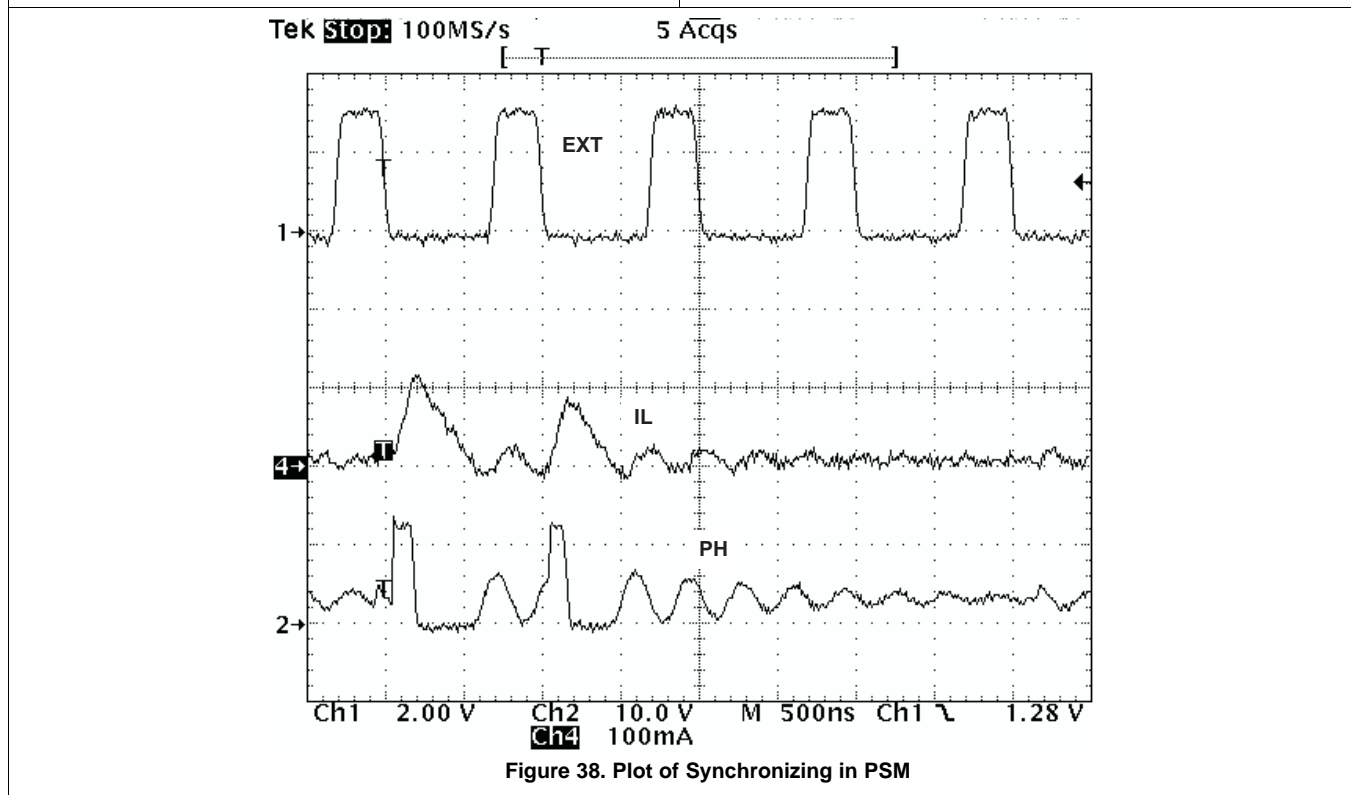
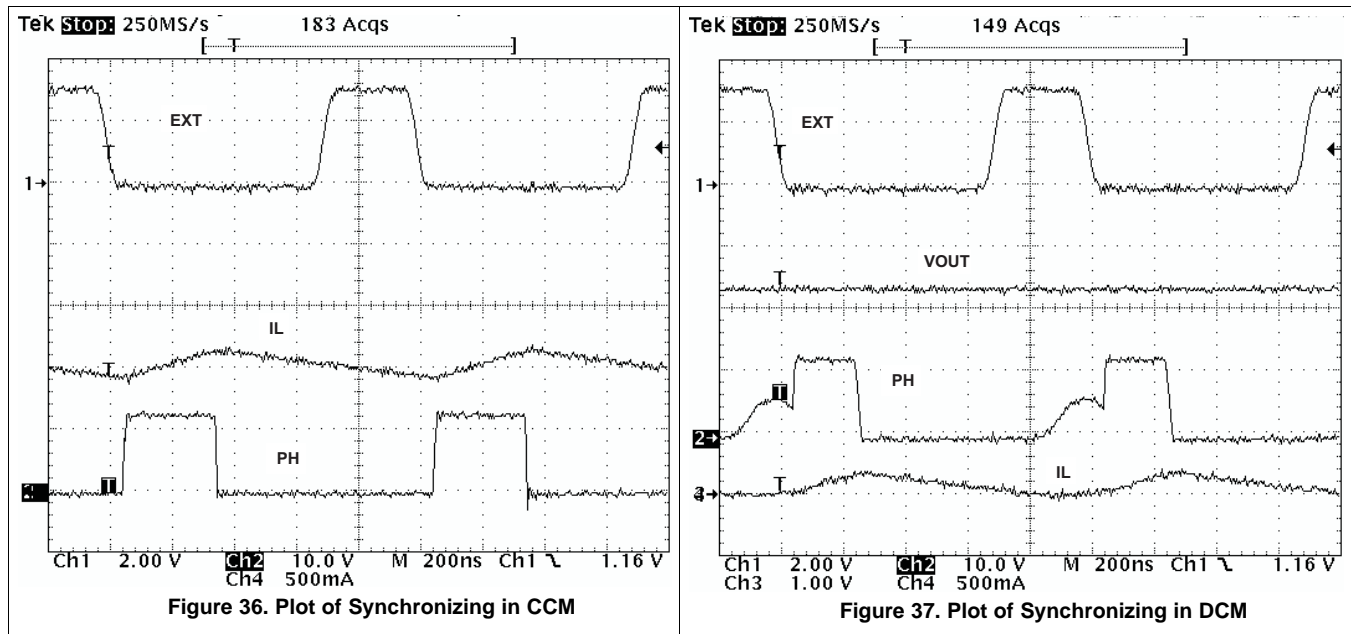

Figure 35. Synchronizing to a System Clock

Application Information (continued)



## 8.2 Typical Application

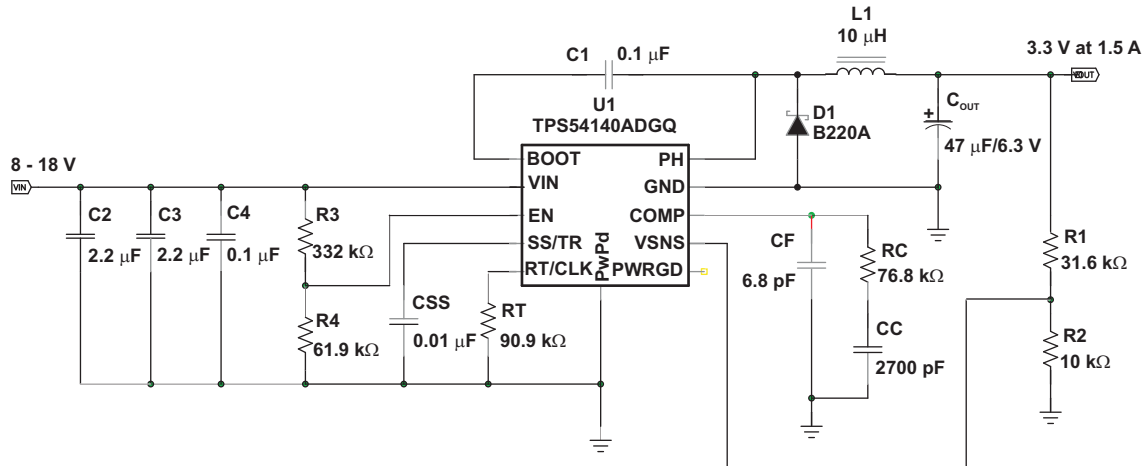

Figure 39. High Frequency, 3.3V Output Power Supply Design with Adjusted UVLO

### 8.2.1 Design Requirements

This example details the design of a high frequency switching regulator design using ceramic output capacitors. A few parameters must be known in order to start the design process. These parameters are typically determined at the system level. For this example, we will start with the following known parameters:

Table 1. Design Parameters

DESIGN PARAMETER	EXAMPLE VALUE
Output Voltage	3.3 V
Transient Response 0 to 1.5-A load step	$\Delta V_{out} = 4\%$
Maximum Output Current	1.5 A
Input Voltage	12 V nom. 8V to 18V
Output Voltage Ripple	$< 33 \text{ mV}_{pp}$
Start Input Voltage (rising VIN)	7.7 V
Stop Input Voltage (falling VIN)	6.7 V

### 8.2.2 Detailed Design Procedure

#### 8.2.2.1 Selecting the Switching Frequency

The first step is to decide on a switching frequency for the regulator. Typically, the user will want to choose the highest switching frequency possible since this will produce the smallest solution size. The high switching frequency allows for lower valued inductors and smaller output capacitors compared to a power supply that switches at a lower frequency. The switching frequency that can be selected is limited by the minimum on-time of the internal power switch, the input voltage and the output voltage and the frequency shift limitation.

Equation 8 and Equation 9 must be used to find the maximum switching frequency for the regulator, choose the lower value of the two equations. Switching frequencies higher than these values will result in pulse skipping or the lack of overcurrent protection during a short circuit.

The typical minimum on time,  $t_{onmin}$ , is 130 ns for the TPS54140A. For this example, the output voltage is 3.3 V and the maximum input voltage is 18 V, which allows for a maximum switch frequency up to 1600 kHz when including the inductor resistance, on resistance and diode voltage in Equation 8. To ensure overcurrent runaway is not a concern during short circuits in your design use Equation 9 or the solid curve in Figure 34 to determine the maximum switching frequency. With an maximum input voltage of 20 V, assuming a diode voltage of 0.5V, inductor resistance of 100 mΩ, switch resistance of 200 mΩ, an output current of 2.8 A, the maximum switching frequency is approximately 1600kHz.

Choosing the lower of the two values and adding some margin a switching frequency of 1200kHz is used. To determine the timing resistance for a given switching frequency, use [Equation 7](#) or the curve in [Figure 32](#).

The switching frequency is set by resistor  $R_t$  shown in [Figure 39](#).

### 8.2.2.2 Output Inductor Selection ( $L_O$ )

To calculate the minimum value of the output inductor, use [Equation 10](#).

$K_{IND}$  is a coefficient that represents the amount of inductor ripple current relative to the maximum output current.

The inductor ripple current will be filtered by the output capacitor. Therefore, choosing high inductor ripple currents will impact the selection of the output capacitor since the output capacitor must have a ripple current rating equal to or greater than the inductor ripple current. In general, the inductor ripple value is at the discretion of the designer; however, the following guidelines may be used.

For designs using low ESR output capacitors such as ceramics, a value as high as  $K_{IND} = 0.3$  may be used. When using higher ESR output capacitors,  $K_{IND} = 0.2$  yields better results. Since the inductor ripple current is part of the PWM control system, the inductor ripple current should always be greater than 100 mA for dependable operation. In a wide input voltage regulator, it is best to choose an inductor ripple current on the larger side. This allows the inductor to still have a measurable ripple current with the input voltage at its minimum.

For this design example, use  $K_{IND} = 0.2$  and the minimum inductor value is calculated to be 7.6  $\mu\text{H}$ . For this design, a nearest standard value was chosen: 10  $\mu\text{H}$ . For the output filter inductor, it is important that the RMS current and saturation current ratings not be exceeded. The RMS and peak inductor current can be found from [Equation 12](#) and [Equation 13](#).

For this design, the RMS inductor current is 1.506 A and the peak inductor current is 1.62 A. The chosen inductor is a MSS6132-103. It has a saturation current rating of 1.64 A and an RMS current rating of 1.9 A.

As the equation set demonstrates, lower ripple currents will reduce the output voltage ripple of the regulator but will require a larger value of inductance. Selecting higher ripple currents will increase the output voltage ripple of the regulator but allow for a lower inductance value.

The current flowing through the inductor is the inductor ripple current plus the output current. During power up, faults or transient load conditions, the inductor current can increase above the calculated peak inductor current level calculated above. In transient conditions, the inductor current can increase up to the switch current limit of the device. For this reason, the most conservative approach is to specify an inductor with a saturation current rating equal to or greater than the switch current limit rather than the peak inductor current.

$$L_{O(\min)} = \frac{V_{IN(\max)} - V_{OUT}}{I_{OUT} \times K_{IND}} \times \frac{V_{OUT}}{V_{IN(\max)} \times f_{SW}} \quad (10)$$

$$I_{RIPPLE} = \frac{V_{OUT} \times (V_{IN(\max)} - V_{OUT})}{V_{IN(\max)} \times L_O \times f_{SW}} \quad (11)$$

$$I_{L(\text{rms})} = \sqrt{\left(I_{OUT}\right)^2 + \frac{1}{12} \times \left(\frac{V_{OUT} \times (V_{IN(\max)} - V_{OUT})}{V_{IN(\max)} \times L_O \times f_{SW}}\right)^2} \quad (12)$$

$$I_{L(\text{peak})} = I_{OUT} + \frac{I_{RIPPLE}}{2} \quad (13)$$

### 8.2.2.3 Output Capacitor

There are three primary considerations for selecting the value of the output capacitor. The output capacitor will determine the modulator pole, the output voltage ripple, and how the regulators responds to a large change in load current. The output capacitance needs to be selected based on the more stringent of these three criteria.

The desired response to a large change in the load current is the first criteria. The output capacitor needs to supply the load with current when the regulator can not. This situation would occur if there are desired hold-up times for the regulator where the output capacitor must hold the output voltage above a certain level for a specified amount of time after the input power is removed. The regulator also will temporarily not be able to supply sufficient output current if there is a large, fast increase in the current needs of the load such as transitioning from no load to a full load. The regulator usually needs two or more clock cycles for the control loop to see the change in load current and output voltage and adjust the duty cycle to react to the change. The output capacitor must be sized to supply the extra current to the load until the control loop responds to the load change. The output capacitance must be large enough to supply the difference in current for 2 clock cycles while only allowing a tolerable amount of droop in the output voltage. Equation 14 shows the minimum output capacitance necessary to accomplish this.

Where  $\Delta I_{out}$  is the change in output current,  $f_{sw}$  is the regulators switching frequency and  $\Delta V_{out}$  is the allowable change in the output voltage. For this example, the transient load response is specified as a 4% change in  $V_{out}$  for a load step from 0A (no load) to 1.5 A (full load). For this example,  $\Delta I_{out} = 1.5 - 0 = 1.5$  A and  $\Delta V_{out} = 0.04 \times 3.3 = 0.132$  V. Using these numbers gives a minimum capacitance of 18.9  $\mu$ F. This value does not take the ESR of the output capacitor into account in the output voltage change. For ceramic capacitors, the ESR is usually small enough to ignore in this calculation. Aluminum electrolytic and tantalum capacitors have higher ESR that should be taken into account.

The catch diode of the regulator can not sink current so any stored energy in the inductor will produce an output voltage overshoot when the load current rapidly decreases, see Figure 40. The output capacitor must also be sized to absorb energy stored in the inductor when transitioning from a high load current to a lower load current. The excess energy that gets stored in the output capacitor will increase the voltage on the capacitor. The capacitor must be sized to maintain the desired output voltage during these transient periods. Equation 15 is used to calculate the minimum capacitance to keep the output voltage overshoot to a desired value. Where  $L$  is the value of the inductor,  $I_{OH}$  is the output current under heavy load,  $I_{OL}$  is the output under light load,  $V_f$  is the final peak output voltage, and  $V_i$  is the initial capacitor voltage. For this example, the worst case load step will be from 1.5 A to 0 A. The output voltage will increase during this load transition and the stated maximum in our specification is 4% of the output voltage. This will make  $V_f = 1.04 \times 3.3 = 3.432$ .  $V_i$  is the initial capacitor voltage which is the nominal output voltage of 3.3 V. Using these numbers in Equation 15 yields a minimum capacitance of 25.3  $\mu$ F.

Equation 16 calculates the minimum output capacitance needed to meet the output voltage ripple specification. Where  $f_{sw}$  is the switching frequency,  $V_{ripple}$  is the maximum allowable output voltage ripple, and  $I_{ripple}$  is the inductor ripple current. Equation 17 yields 0.7  $\mu$ F.

Equation 17 calculates the maximum ESR an output capacitor can have to meet the output voltage ripple specification. Equation 17 indicates the ESR should be less than 144m $\Omega$ .

The most stringent criteria for the output capacitor is 25.3  $\mu$ F of capacitance to keep the output voltage in regulation during an unload transient.

Additional capacitance de-ratings for aging, temperature and dc bias should be factored in which will increase this minimum value. For this example, a 47  $\mu$ F 6.3V X7R ceramic capacitor with 5 m $\Omega$  of ESR will be used.

Capacitors generally have limits to the amount of ripple current they can handle without failing or producing excess heat. An output capacitor that can support the inductor ripple current must be specified. Some capacitor data sheets specify the Root Mean Square (RMS) value of the maximum ripple current. Equation 18 can be used to calculate the RMS ripple current the output capacitor needs to support. For this application, Equation 18 yields 66mA.

$$C_{OUT} > \frac{2 \times \Delta I_{OUT}}{f_{SW} \times \Delta V_{OUT}} \quad (14)$$

$$C_{OUT} > L_O \times \frac{((I_{OH})^2 - (I_{OL})^2)}{((V_f)^2 - (V_i)^2)} \quad (15)$$

$$C_{OUT} > \frac{1}{8 \times f_{SW}} \times \frac{1}{\left( \frac{V_{OUT(ripple)}}{I_{RIPPLE}} \right)} \quad (16)$$

$$R_{ESR} = \frac{V_{OUT(ripple)}}{I_{RIPPLE}} \quad (17)$$

$$I_{COUT(rms)} = \frac{V_{OUT} \times (V_{IN(max)} - V_{OUT})}{\sqrt{12} \times V_{IN(max)} \times L_O \times f_{SW}} \quad (18)$$

#### 8.2.2.4 Catch Diode

The TPS54140A requires an external catch diode between the PH pin and GND. The selected diode must have a reverse voltage rating equal to or greater than  $V_{IN(max)}$ . The peak current rating of the diode must be greater than the maximum inductor current. The diode should also have a low forward voltage. Schottky diodes are typically a good choice for the catch diode due to their low forward voltage. The lower the forward voltage of the diode, the higher the efficiency of the regulator will be.

Typically, the higher the voltage and current ratings the diode has, the higher the forward voltage will be. Since the design example has an input voltage up to 18 V, a diode with a minimum of 20 V reverse voltage will be selected.

For the example design, the B220A Schottky diode is selected for its lower forward voltage and it comes in a larger package size which has good thermal characteristics over small devices. The typical forward voltage of the B220A is 0.50 volts.

The diode must also be selected with an appropriate power rating. The diode conducts the output current during the off-time of the internal power switch. The off-time of the internal switch is a function of the maximum input voltage, the output voltage, and the switching frequency. The output current during the off-time is multiplied by the forward voltage of the diode which equals the conduction losses of the diode. At higher switch frequencies, the ac losses of the diode need to be taken into account. The ac losses of the diode are due to the charging and discharging of the junction capacitance and reverse recovery. Equation 19 is used to calculate the total power dissipation, conduction losses plus ac losses, of the diode.

The B220A has a junction capacitance of 120 pF. Using Equation 19, the selected diode will dissipate 0.632 Watts. This power dissipation, depending on mounting techniques, should produce a 16°C temperature rise in the diode when the input voltage is 18V and the load current is 1.5 A.

If the power supply spends a significant amount of time at light load currents or in sleep mode consider using a diode which has a low leakage current and slightly higher forward voltage drop.

$$P_D = \frac{(V_{IN(max)} - V_{OUT}) \times I_{OUT} \times V_f d}{V_{IN(max)}} + \frac{C_j \times f_{SW} \times (V_{IN} + V_f d)^2}{2} \quad (19)$$

#### 8.2.2.5 Input Capacitor

The TPS54140A requires a high quality ceramic, type X5R or X7R, input decoupling capacitor of at least 3  $\mu$ F of effective capacitance and in some applications a bulk capacitance. The effective capacitance includes any dc bias effects. The voltage rating of the input capacitor must be greater than the maximum input voltage. The capacitor must also have a ripple current rating greater than the maximum input current ripple of the TPS54140A. The input ripple current can be calculated using Equation 20.

The value of a ceramic capacitor varies significantly over temperature and the amount of dc bias applied to the capacitor. The capacitance variations due to temperature can be minimized by selecting a dielectric material that is stable over temperature. X5R and X7R ceramic dielectrics are usually selected for power regulator capacitors because they have a high capacitance to volume ratio and are fairly stable over temperature. The output capacitor must also be selected with the dc bias taken into account. The capacitance value of a capacitor decreases as the dc bias across a capacitor increases.

For this example design, a ceramic capacitor with at least a 20 V voltage rating is required to support the maximum input voltage. Common standard ceramic capacitor voltage ratings include 4 V, 6.3 V, 10 V, 16V, 25 V, 50 V or 100V so a 25 V capacitor should be selected. For this example, two 2.2  $\mu\text{F}$ , 25 V capacitors in parallel have been selected. [Table 2](#) shows a selection of high voltage capacitors. The input capacitance value determines the input ripple voltage of the regulator. The input voltage ripple can be calculated using [Equation 21](#). Using the design example values,  $I_{\text{OUT(max)}} = 1.5 \text{ A}$ ,  $C_{\text{IN}} = 4.4 \mu\text{F}$ ,  $f_{\text{SW}} = 1200 \text{ kHz}$ , yields an input voltage ripple of 71 mV and a rms input ripple current of 0.701 A.

$$I_{\text{CI(rms)}} = I_{\text{OUT}} \times \sqrt{\frac{V_{\text{OUT}}}{V_{\text{IN(min)}}} \times \frac{(V_{\text{IN(min)}} - V_{\text{OUT}})}{V_{\text{IN(min)}}}} \quad (20)$$

$$\Delta V_{\text{IN}} = \frac{I_{\text{OUT(max)}} \times 0.25}{C_{\text{IN}} \times f_{\text{SW}}} \quad (21)$$

**Table 2. Capacitor Types**

VENDOR	VALUE ( $\mu\text{F}$ )	EIA Size	VOLTAGE	DIELECTRIC	COMMENTS
Murata	1.0 to 2.2	1210	100 V	X7R	GRM32 series
	1.0 to 4.7		50 V		
	1.0	1206	100 V		GRM31 series
	1.0 to 2.2		50 V		
Vishay	1.0 10 1.8	2220	50 V		VJ X7R series
	1.0 to 1.2		100 V		
	1.0 to 3.9	2225	50 V		
	1.0 to 1.8		100 V		
TDK	1.0 to 2.2	1812	100 V		C series C4532
	1.5 to 6.8		50 V		
	1.0. to 2.2	1210	100 V	C series C3225	
	1.0 to 3.3		50 V		
AVX	1.0 to 4.7	1210	50 V	X7R dielectric series	
	1.0		100 V		
	1.0 to 4.7	1812	50 V		
	1.0 to 2.2		100 V		

### 8.2.2.6 Slow Start Capacitor

The slow start capacitor determines the minimum amount of time it will take for the output voltage to reach its nominal programmed value during power up. This is useful if a load requires a controlled voltage slew rate. This is also used if the output capacitance is very large and would require large amounts of current to charge the capacitor to the output voltage level. The large currents necessary to charge the capacitor may make the TPS54140A reach the current limit or excessive current draw from the input power supply may cause the input voltage rail to sag. Limiting the output voltage slew rate solves both of these problems.

The slow start time must be long enough to allow the regulator to charge the output capacitor up to the output voltage without drawing excessive current. [Equation 22](#) can be used to find the minimum slow start time,  $t_{\text{SS}}$ , necessary to charge the output capacitor,  $C_{\text{OUT}}$ , from 10% to 90% of the output voltage,  $V_{\text{OUT}}$ , with an average slow start current of  $I_{\text{SS(avg)}}$ . In the example, to charge the 47  $\mu\text{F}$  output capacitor up to 3.3 V while only allowing the average input current to be 0.125 A would require a 1 ms slow start time.

Once the slow start time is known, the slow start capacitor value can be calculated using [Equation 6](#). For the example circuit, the slow start time is not too critical since the output capacitor value is 47  $\mu\text{F}$  which does not require much current to charge to 3.3 V. The example circuit has the slow start time set to an arbitrary value of 1ms which requires a 3.3 nF capacitor.

$$t_{\text{SS}} > \frac{C_{\text{OUT}} \times V_{\text{OUT}} \times 0.8}{I_{\text{SS(avg)}}} \quad (22)$$

### 8.2.2.7 Bootstrap Capacitor Selection

A 0.1- $\mu$ F ceramic capacitor must be connected between the BOOT and PH pins for proper operation. It is recommended to use a ceramic capacitor with X5R or better grade dielectric. The capacitor should have a 10-V or higher voltage rating.

### 8.2.2.8 Undervoltage Lock Out Set Point

The Under Voltage Lock Out (UVLO) can be adjusted using an external voltage divider on the EN pin of the TPS54140A. The UVLO has two thresholds, one for power up when the input voltage is rising and one for power down or brown outs when the input voltage is falling. For the example design, the supply should turn on and start switching once the input voltage increases above 7.7 V (enabled). After the regulator starts switching, it should continue to do so until the input voltage falls below 6.7 V (UVLO stop).

The programmable UVLO and enable voltages are set using a resistor divider between Vin and ground to the EN pin. Equation 2 through Equation 3 can be used to calculate the resistance values necessary. For the example application, a 332 k $\Omega$  between Vin and EN and a 61.9 k $\Omega$  between EN and ground are required to produce the 7.7 and 6.7 volt start and stop voltages.

### 8.2.2.9 Output Voltage and Feedback Resistors Selection

For the example design, 10.0 k $\Omega$  was selected for R2. Using Equation 1, R1 is calculated as 31.25 k $\Omega$ . The nearest standard 1% resistor is 31.6 k $\Omega$ . Due to current leakage of the VSENSE pin, the current flowing through the feedback network should be greater than 1  $\mu$ A in order to maintain the output voltage accuracy. This requirement makes the maximum value of R2 equal to 800 k $\Omega$ . Choosing higher resistor values will decrease quiescent current and improve efficiency at low output currents but may introduce noise immunity problems.

### 8.2.2.10 Compensation

There are several industry techniques used to compensate DC/DC regulators. The method presented here yields high phase margins. For most conditions, the regulator will have a phase margin between 60 and 90 degrees. The method presented here ignores the effects of the slope compensation that is internal to the TPS54140A. Since the slope compensation is ignored, the actual cross over frequency is usually lower than the cross over frequency used in the calculations.

Use SwitcherPro software for a more accurate design.

The uncompensated regulator will have a dominant pole, typically located between 300 Hz and 3 kHz, due to the output capacitor and load resistance and a pole due to the error amplifier. One zero exists due to the output capacitor and the ESR. The zero frequency is higher than either of the two poles.

If left uncompensated, the double pole created by the error amplifier and the modulator would lead to an unstable regulator. To stabilize the regulator, one pole must be canceled out. One design approach is to locate a compensating zero at the modulator pole. Then select a cross over frequency that is higher than the modulator pole. The gain of the error amplifier can be calculated to achieve the desired cross over frequency. The capacitor used to create the compensation zero along with the output impedance of the error amplifier form a low frequency pole to provide a minus one slope through the cross over frequency. Then a compensating pole is added to cancel the zero due to the output capacitors ESR. If the ESR zero resides at a frequency higher than the switching frequency then it can be ignored.

To compensate the TPS54140A using this method, first calculate the modulator pole and zero using the following equations:

$$f_{P(\text{mod})} = \frac{I_{\text{OUT}(\text{max})}}{2 \times \pi \times V_{\text{OUT}} \times C_{\text{OUT}}}$$

where

- $I_{\text{OUT}(\text{max})}$  is the maximum output current
  - $C_{\text{OUT}}$  is the output capacitance
  - $V_{\text{OUT}}$  is the nominal output voltage
- (23)

$$f_{Z(\text{mod})} = \frac{1}{2 \times \pi \times R_{\text{ESR}} \times C_{\text{OUT}}}$$
(24)

For the example design, the modulator pole is located at 1.5 kHz and the ESR zero is located at 338 kHz.

Next, the designer needs to select a crossover frequency which will determine the bandwidth of the control loop. The cross over frequency must be located at a frequency at least five times higher than the modulator pole. The cross over frequency must also be selected so that the available gain of the error amplifier at the cross over frequency is high enough to allow for proper compensation.

[Equation 29](#) is used to calculate the maximum cross over frequency when the ESR zero is located at a frequency that is higher than the desired cross over frequency. This will usually be the case for ceramic or low ESR tantalum capacitors. Aluminum Electrolytic and Tantalum capacitors will typically produce a modulator zero at a low frequency due to their high ESR.

The example application is using a low ESR ceramic capacitor with 10 mΩ of ESR making the zero at 338 kHz.

This value is much higher than typical crossover frequencies so the maximum crossover frequency is calculated using both [Equation 25](#) and [Equation 28](#).

Using [Equation 28](#) gives a minimum crossover frequency of 7.6 kHz and [Equation 25](#) gives a maximum crossover frequency of 45.3 kHz.

A crossover frequency of 45 kHz is arbitrarily selected from this range.

For ceramic capacitors use [Equation 25](#):

$$f_{C(\max)} \leq 2100 \sqrt{\frac{f_{P(\text{mod})}}{V_{\text{OUT}}}} \quad (25)$$

For tantalum or aluminum capacitors use [Equation 26](#):

$$f_{C(\max)} \leq \frac{51442}{\sqrt{V_{\text{OUT}}}} \quad (26)$$

For all cases use [Equation 27](#) and [Equation 28](#):

$$f_{C(\max)} \leq \frac{f_{\text{SW}}}{5} \quad (27)$$

$$f_{C(\min)} \geq 5 \times f_{P(\text{mod})} \quad (28)$$

Once a cross over frequency,  $f_c$ , has been selected, the gain of the modulator at the cross over frequency is calculated. The gain of the modulator at the cross over frequency is calculated using [Equation 29](#).

$$G_{\text{MOD}(f_c)} = \frac{g_{m(\text{PS})} \times R_{\text{LOAD}} \times (2\pi \times f_c \times C_{\text{OUT}} \times R_{\text{ESR}} + 1)}{2\pi \times f_c \times C_{\text{OUT}} \times (R_{\text{LOAD}} + R_{\text{ESR}}) + 1} \quad (29)$$

For the example problem, the gain of the modulator at the cross over frequency is 0.542. Next, the compensation components are calculated. A resistor in series with a capacitor is used to create a compensating zero. A capacitor in parallel to these two components forms the compensating pole. However, calculating the values of these components varies depending on if the ESR zero is located above or below the cross over frequency. For ceramic or low ESR tantalum output capacitors, the zero will usually be located above the cross over frequency. For aluminum electrolytic and tantalum capacitors, the modulator zero is usually located lower in frequency than the cross over frequency. For cases where the modulator zero is higher than the cross over frequency (ceramic capacitors).

$$R_C = \frac{V_{\text{OUT}}}{G_{\text{MOD}(f_c)} \times g_{m(\text{EA})} \times V_{\text{REF}}} \quad (30)$$

$$C_C = \frac{1}{2\pi \times R_C \times f_{P(\text{mod})}} \quad (31)$$

$$C_f = \frac{C_{\text{OUT}} \times R_{\text{ESR}}}{R_C} \quad (32)$$

For cases where the modulator zero is less than the cross over frequency (Aluminum or Tantalum capacitors), the equations are:

$$R_C = \frac{V_{OUT}}{G_{MOD}(f_c) \times f_{Z(mod)} \times gm_{(EA)} \times V_{REF}} \quad (33)$$

$$C_C = \frac{1}{2\pi \times R_C \times f_{P(mod)}} \quad (34)$$

$$C_f = \frac{1}{2\pi \times R_C \times f_{Z(mod)}} \quad (35)$$

For the example problem, the ESR zero is located at a higher frequency compared to the cross over frequency so Equation 32 through Equation 35 are used to calculate the compensation components. For the example problem, the components are calculated to be:  $R_C = 76.2 \text{ k}\Omega$ ,  $C_C = 2710 \text{ pF}$ , and  $C_f = 6.17 \text{ pF}$ .

The calculated value of the  $C_f$  capacitor is not a standard value so a value of 2700 pF will be used. 6.8 pF is used for  $C_C$ .  $R_C$  resistor sets the gain of the error amplifier which determines the cross over frequency. The calculated  $R_C$  resistor is not a standard value, so 76.8k $\Omega$  will be used.

### 8.2.3 Application Curves

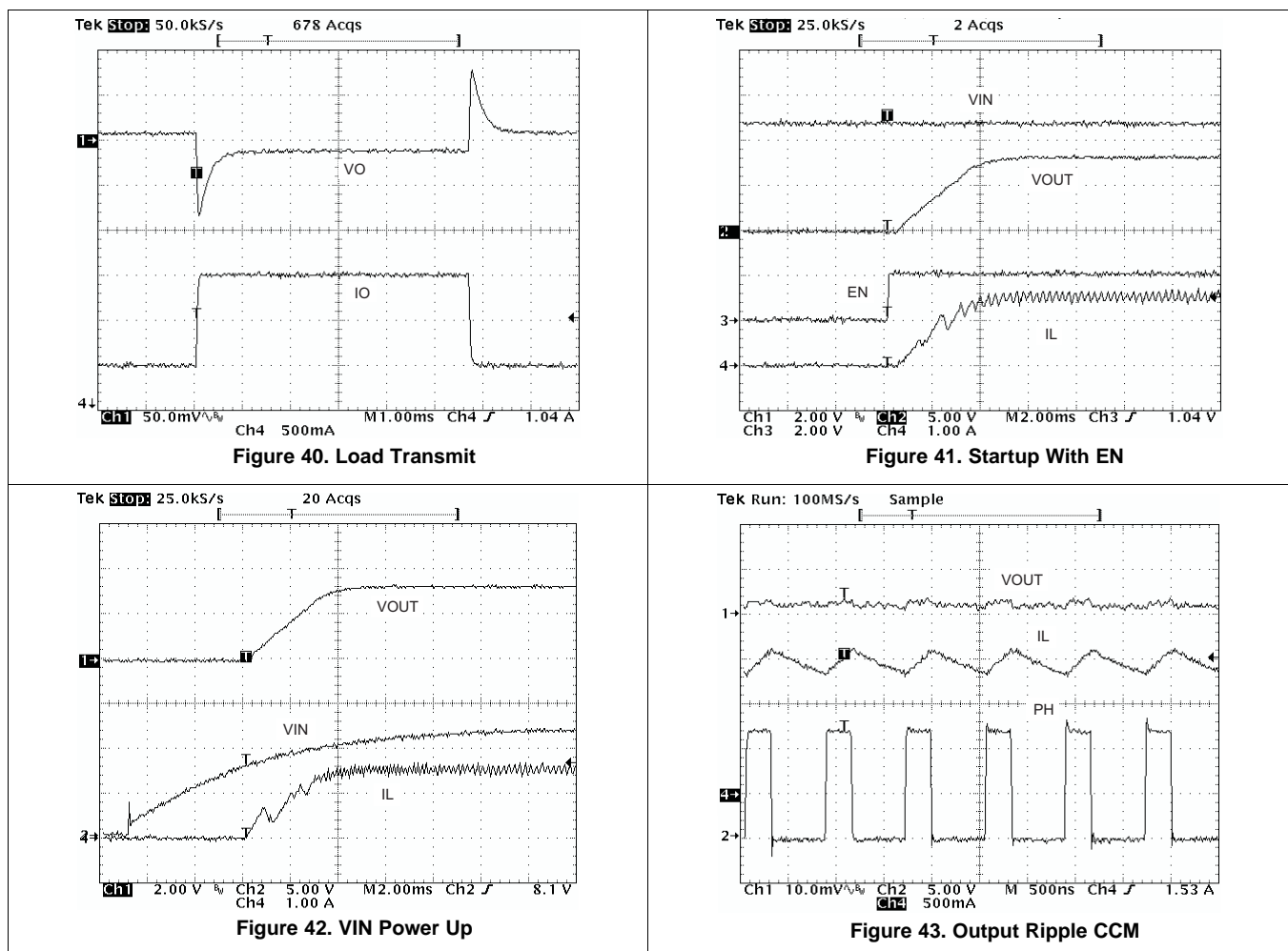

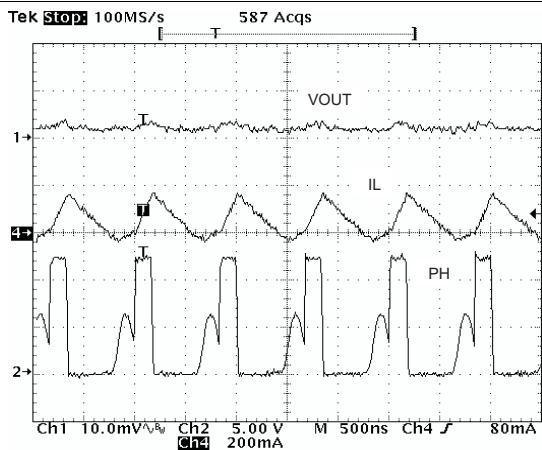

Figure 44. Output Ripple, DCM

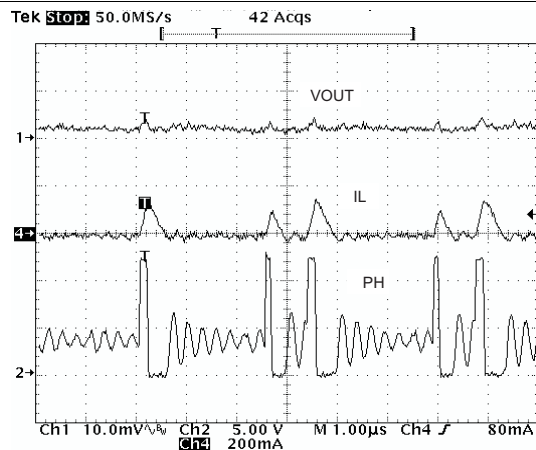

Figure 45. Output Ripple, PSM

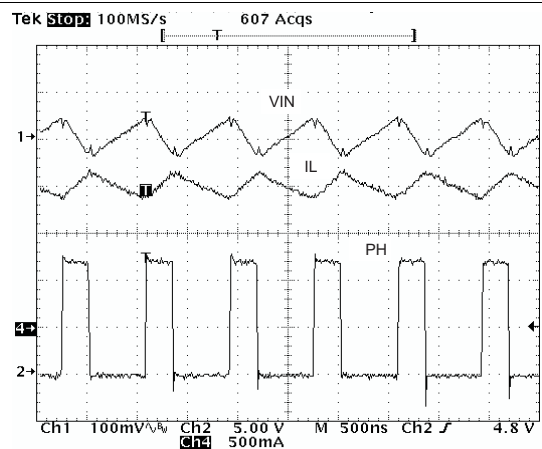

Figure 46. Input Ripple CCM

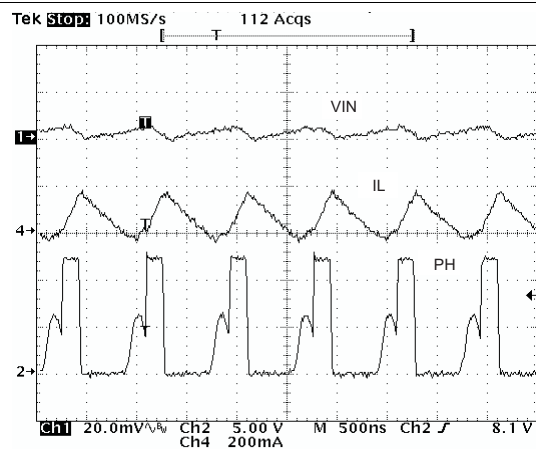

Figure 47. Input Ripple DCM

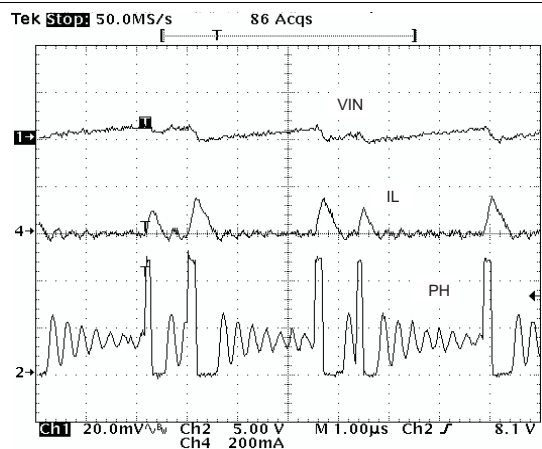

Figure 48. Input Ripple PSM

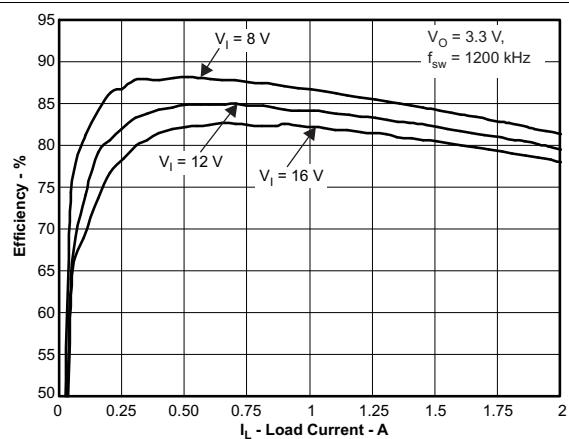
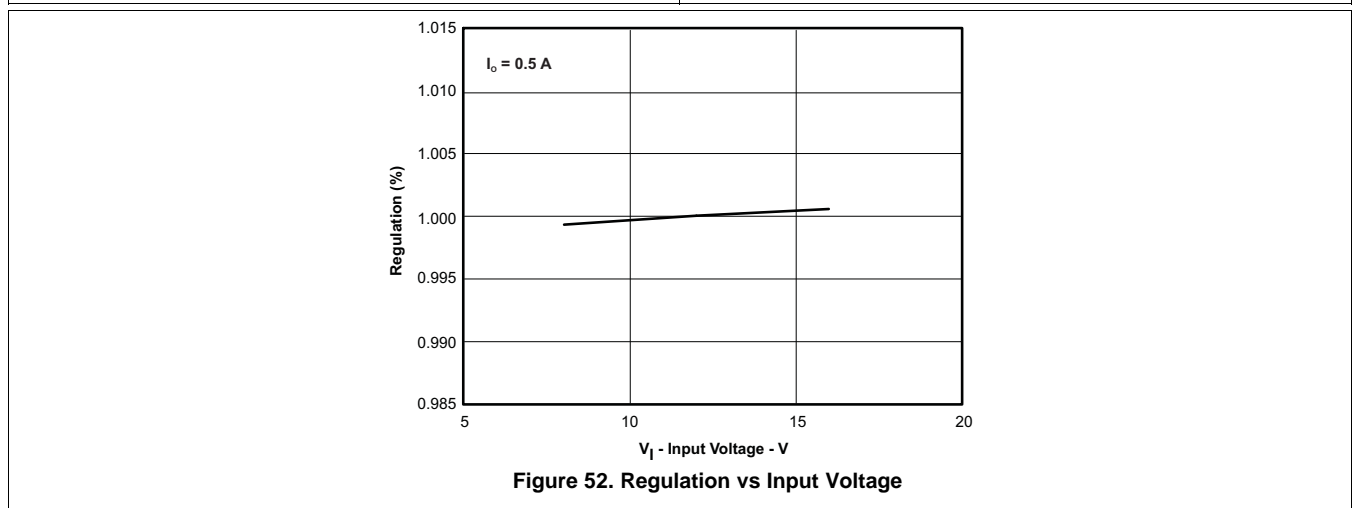
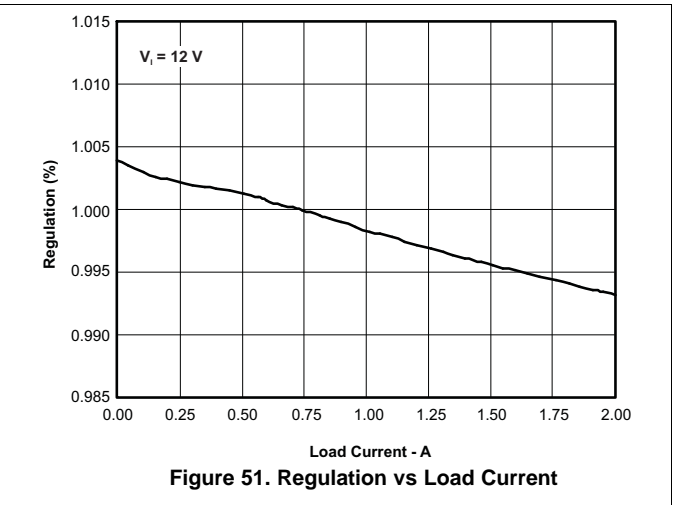
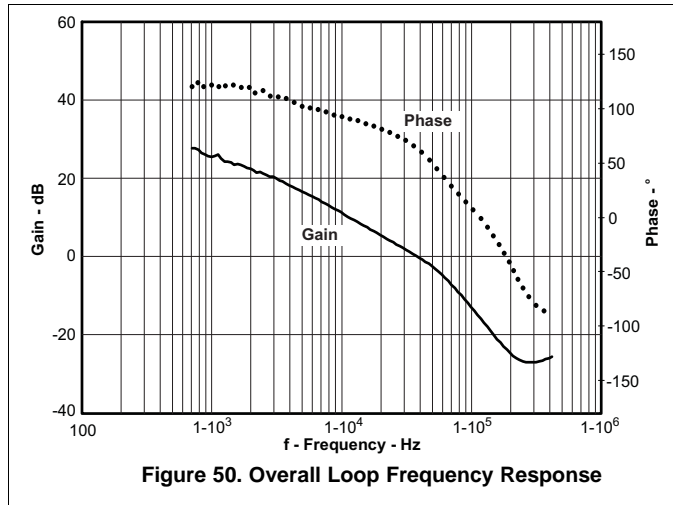

Figure 49. Efficiency vs Load Current



## 8.3 System Examples

### 8.3.1 Simple Small Signal Model for Peak Current Mode Control

Figure 53 describes a simple small signal model that can be used to understand how to design the frequency compensation. The TPS54140A power stage can be approximated to a voltage-controlled current source (duty cycle modulator) supplying current to the output capacitor and load resistor. The control to output transfer function is shown in Equation 36 and consists of a dc gain, one dominant pole, and one ESR zero. The quotient of the change in switch current and the change in COMP pin voltage (node c in Figure 56) is the power stage transconductance. The  $gm_{ps}$  for the TPS54140A is 6 A/V. The low-frequency gain of the power stage frequency response is the product of the transconductance and the load resistance as shown in Equation 37.

As the load current increases and decreases, the low-frequency gain decreases and increases, respectively. This variation with the load may seem problematic at first glance, but fortunately the dominant pole moves with the load current (see Equation 38). The combined effect is highlighted by the dashed line in the right half of Figure 53. As the load current decreases, the gain increases and the pole frequency lowers, keeping the 0-dB crossover frequency the same for the varying load conditions which makes it easier to design the frequency compensation. The type of output capacitor chosen determines whether the ESR zero has a profound effect on the frequency compensation design. Using high ESR aluminum electrolytic capacitors may reduce the number frequency compensation components needed to stabilize the overall loop because the phase margin increases from the ESR zero at the lower frequencies (see Equation 39).

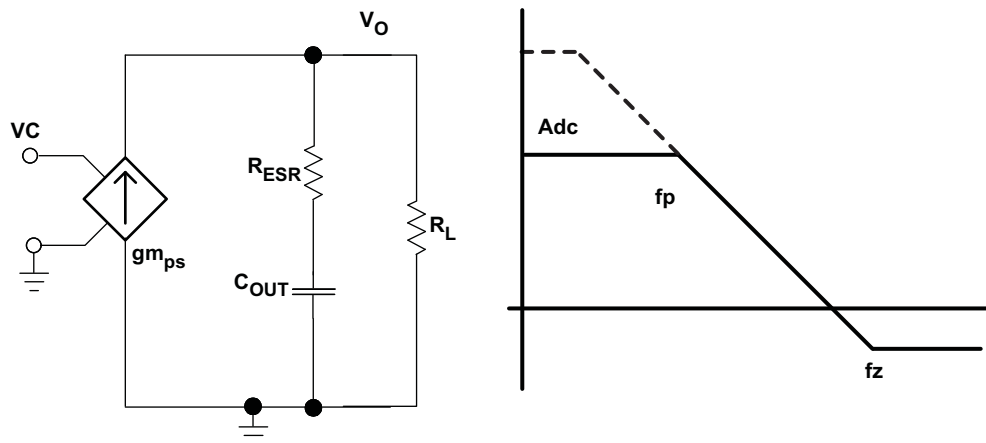

Figure 53. Simple Small Signal Model and Frequency Response for Peak Current Mode Control

$$\frac{V_{OUT}}{V_C} = A_{dc} \times \frac{\left(1 + \frac{s}{2\pi \times f_Z}\right)}{\left(1 + \frac{s}{2\pi \times f_P}\right)} \quad (36)$$

$$A_{dc} = gm_{ps} \times R_L \quad (37)$$

$$f_P = \frac{1}{C_{OUT} \times R_L \times 2\pi} \quad (38)$$

$$f_Z = \frac{1}{C_{OUT} \times R_{ESR} \times 2\pi} \quad (39)$$

## System Examples (continued)

### 8.3.2 Small Signal Model for Frequency Compensation

The TPS54140A uses a transconductance amplifier for the error amplifier and readily supports three of the commonly-used frequency compensation circuits. Compensation circuits Type 2A, Type 2B, and Type 1 are shown in Figure 54. Type 2 circuits most likely implemented in high bandwidth power-supply designs using low ESR output capacitors. The Type 1 circuit is used with power-supply designs with high-ESR aluminum electrolytic or tantalum capacitors. Equation 40 and Equation 41 show how to relate the frequency response of the amplifier to the small signal model in Figure 54. The open-loop gain and bandwidth are modeled using the  $R_O$  and  $C_O$  shown in Figure 54. See Figure 39 for a design example using a Type 2A network with a low ESR output capacitor.

Equation 40 through Equation 49 are provided as a reference for those who prefer to compensate using the preferred methods. Those who prefer to use prescribed method use the method outlined in the application section or use switched information.

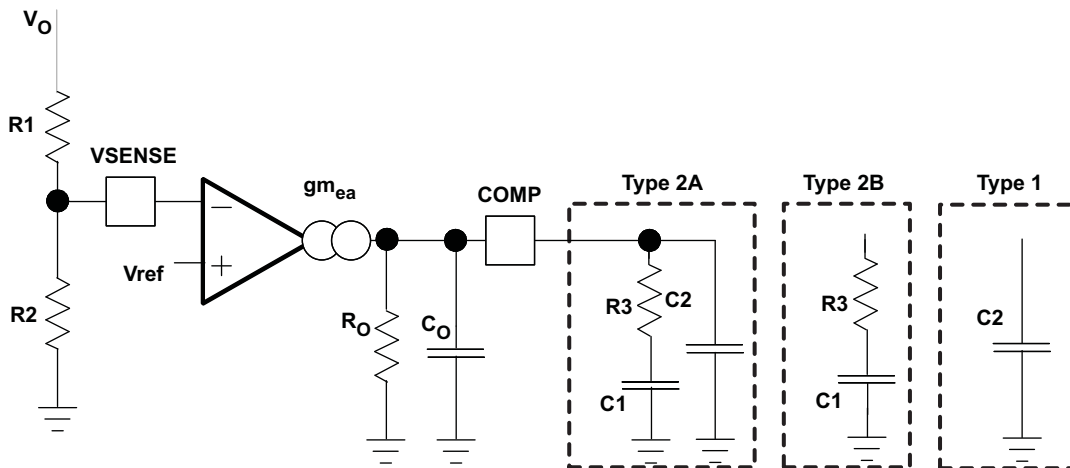

Figure 54. Types of Frequency Compensation

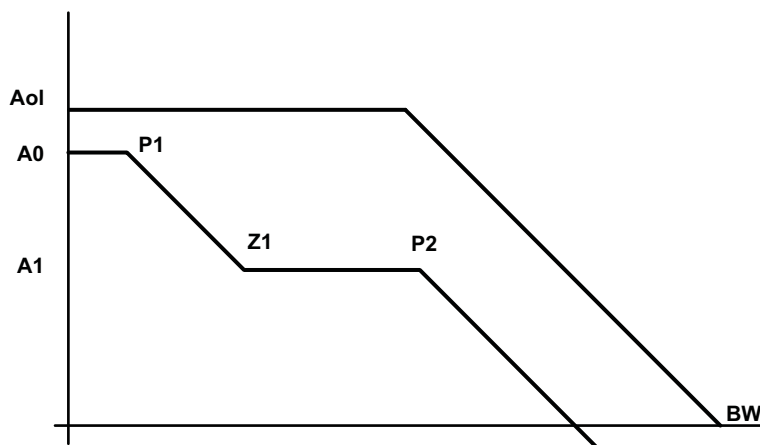

Figure 55. Frequency Response of the Type 2A and Type 2B Frequency Compensation

### System Examples (continued)

$$R_o = \frac{A_{ol}(V/V)}{g_{m_{ea}}} \quad (40)$$

$$C_{OUT} = \frac{g_{m_{ea}}}{2\pi \times BW \text{ (Hz)}} \quad (41)$$

$$EA = A_0 \times \frac{\left(1 + \frac{s}{2\pi \times f_{Z1}}\right)}{\left(1 + \frac{s}{2\pi \times f_{P1}}\right) \times \left(1 + \frac{s}{2\pi \times f_{P2}}\right)} \quad (42)$$

$$A_0 = g_{m_{ea}} \times R_o \times \frac{R_2}{R_1 + R_2} \quad (43)$$

$$A_1 = g_{m_{ea}} \times R_o || R_3 \times \frac{R_2}{R_1 + R_2} \quad (44)$$

$$P_1 = \frac{1}{2\pi \times R_o \times C_1} \quad (45)$$

$$Z_1 = \frac{1}{2\pi \times R_3 \times C_1} \quad (46)$$

$$P_2 = \frac{1}{2\pi \times R_3 || R \times (C_2 + C_{OUT})} \text{ type 2a} \quad (47)$$

$$P_2 = \frac{1}{2\pi \times R_3 || R \times C_{OUT}} \text{ type 2b} \quad (48)$$

$$P_2 = \frac{1}{2\pi \times R \times (C_2 + C_{OUT})} \text{ type 1} \quad (49)$$

### 8.3.3 Small Signal Model for Loop Response

Figure 56 shows an equivalent model for the TPS54140A control loop which can be modeled in a circuit simulation program to check frequency response and dynamic load response. The error amplifier is a transconductance amplifier with a  $g_{m_{EA}}$  of 97  $\mu A/V$ . The error amplifier can be modeled using an ideal voltage controlled current source. The resistor  $R_o$  and capacitor  $C_o$  model the open loop gain and frequency response of the amplifier. The 1mV ac voltage source between the nodes a and b effectively breaks the control loop for the frequency response measurements. Plotting c/a shows the small signal response of the frequency compensation. Plotting a/b shows the small signal response of the overall loop. The dynamic loop response can be checked by replacing  $R_L$  with a current source with the appropriate load step amplitude and step rate in a time domain analysis. This equivalent model is only valid for continuous conduction mode designs.

**System Examples (continued)**

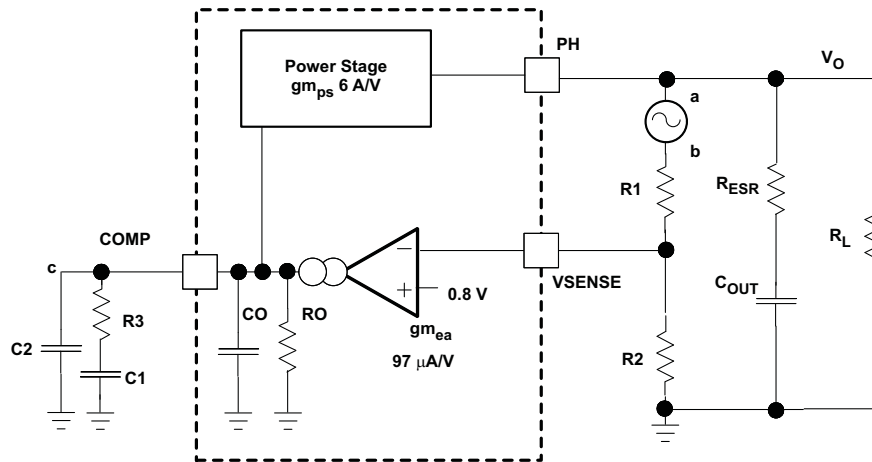

**Figure 56. Small Signal Model for Loop Response**

## 9 Power Supply Recommendations

The devices are designed to operate from an input voltage supply range between 3.5 V and 60 V. This input supply should be well regulated. If the input supply is located more than a few inches from the TPS54160 converter additional bulk capacitance may be required in addition to the ceramic bypass capacitors. An electrolytic capacitor with a value of 100  $\mu$ F is a typical choice

### 9.1 Sequencing

Many of the common power supply sequencing methods can be implemented using the SS/TR, EN, and PWRGD pins. The sequential method can be implemented using an open drain output of a power on reset pin of another device. The sequential method is illustrated in Figure 57 using two TPS54140A devices. The power good is coupled to the EN pin on the TPS54140A which will enable the second power supply once the primary supply reaches regulation. If needed, a 1nF ceramic capacitor on the EN pin of the second power supply will provide a 1ms start up delay. Figure 58 shows the results of Figure 57.

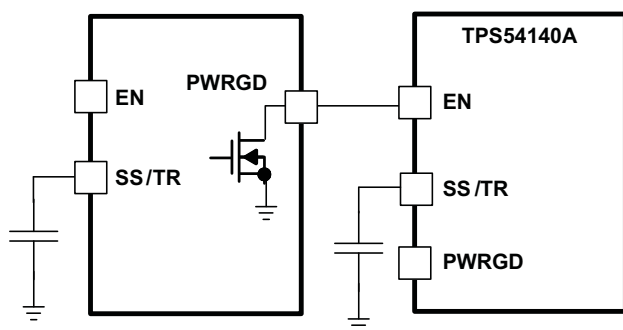

Figure 57. Schematic for Sequential Start-Up Sequence

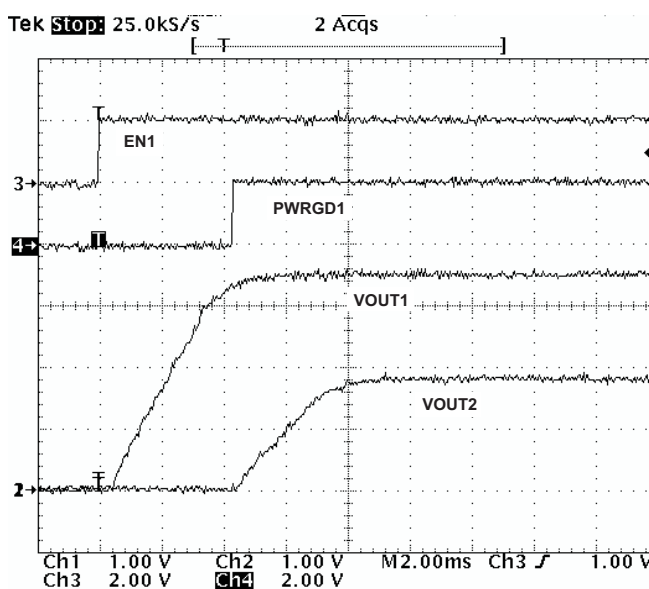

Figure 58. Sequential Startup using EN and PWRGD

Sequencing (continued)

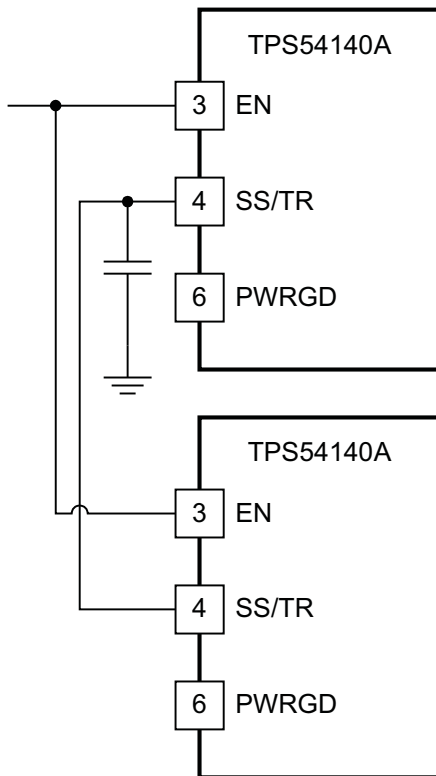

Figure 59. Schematic for Ratio-metric Start-Up Sequence

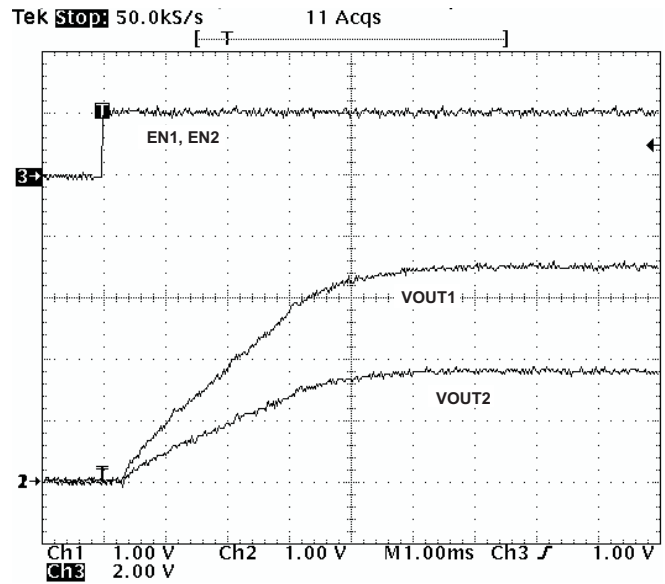

Figure 60. Ratio-Metric Startup using Coupled SS/TR pins

Figure 59 shows a method for ratio-metric start up sequence by connecting the SS/TR pins together. The regulator outputs will ramp up and reach regulation at the same time. When calculating the slow start time the pullup current source must be doubled in Equation 6. Figure 60 shows the results of Figure 59.

Sequencing (continued)

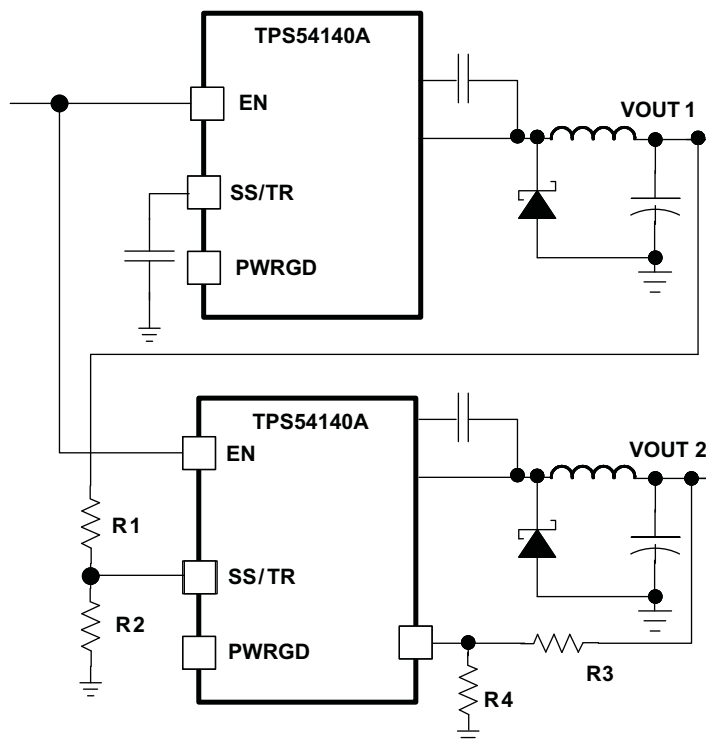

Figure 61. Schematic for Ratiometric and Simultaneous Start-Up Sequence

Ratio-metric and simultaneous power supply sequencing can be implemented by connecting the resistor network of R1 and R2 shown in Figure 61 to the output of the power supply that needs to be tracked or another voltage reference source. Using Equation 50 and Equation 51, the tracking resistors can be calculated to initiate the Vout2 slightly before, after or at the same time as Vout1. Equation 52 is the voltage difference between Vout1 and Vout2 at the 95% of nominal output regulation.

The deltaV variable is zero volts for simultaneous sequencing. To minimize the effect of the inherent SS/TR to VSENSE offset (V<sub>ssoffset</sub>) in the slow start circuit and the offset created by the pullup current source (I<sub>ss</sub>) and tracking resistors, the V<sub>ssoffset</sub> and I<sub>ss</sub> are included as variables in the equations.

To design a ratio-metric start up in which the Vout2 voltage is slightly greater than the Vout1 voltage when Vout2 reaches regulation, use a negative number in Equation 50 through Equation 52 for deltaV. Equation 52 will result in a positive number for applications which the Vout2 is slightly lower than Vout1 when Vout2 regulation is achieved.

Since the SS/TR pin must be pulled below 40 mV before starting after an EN, UVLO or thermal shutdown fault, careful selection of the tracking resistors is needed to ensure the device will restart after a fault. Make sure the calculated R1 value from Equation 50 is greater than the value calculated in Equation 53 to ensure the device can recover from a fault.

As the SS/TR voltage becomes more than 85% of the nominal reference voltage the V<sub>ssoffset</sub> becomes larger as the slow start circuits gradually handoff the regulation reference to the internal voltage reference. The SS/TR pin voltage needs to be greater than 1.3 V for a complete handoff to the internal voltage reference as shown in Figure 23.

$$R1 = \frac{V_{OUT2} + \Delta V}{V_{REF}} + \frac{V_{SS(offset)}}{I_{SS}} \tag{50}$$

$$R2 = \frac{V_{REF} \times R1}{V_{OUT2} + \Delta V - V_{REF}} \tag{51}$$

**Sequencing (continued)**

$$\Delta V = V_{OUT1} - V_{OUT2} \tag{52}$$

$$R1 > 2800 \times V_{OUT1} - 180 \times \Delta V \tag{53}$$

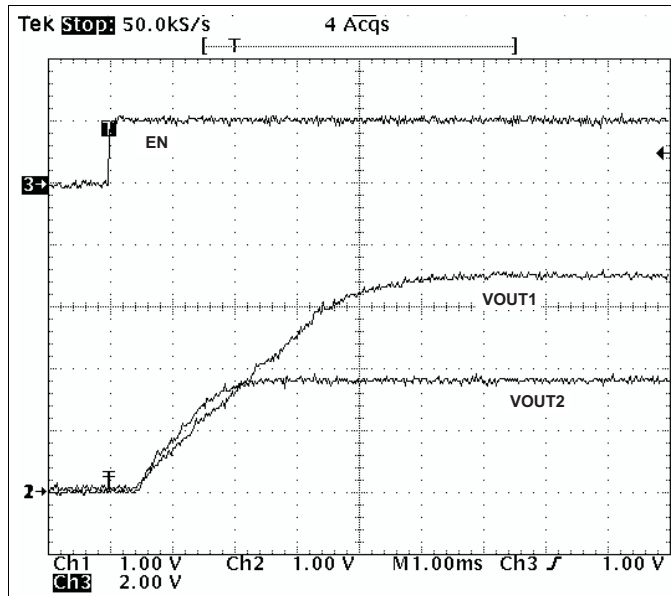

Figure 62. Ratio-metric Startup with Tracking Resistors

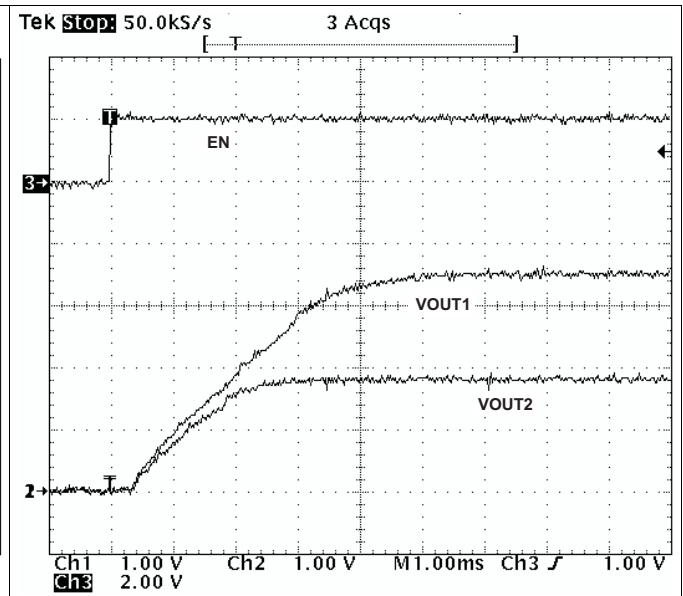

Figure 63. Ratiometric Startup with Tracking Resistors

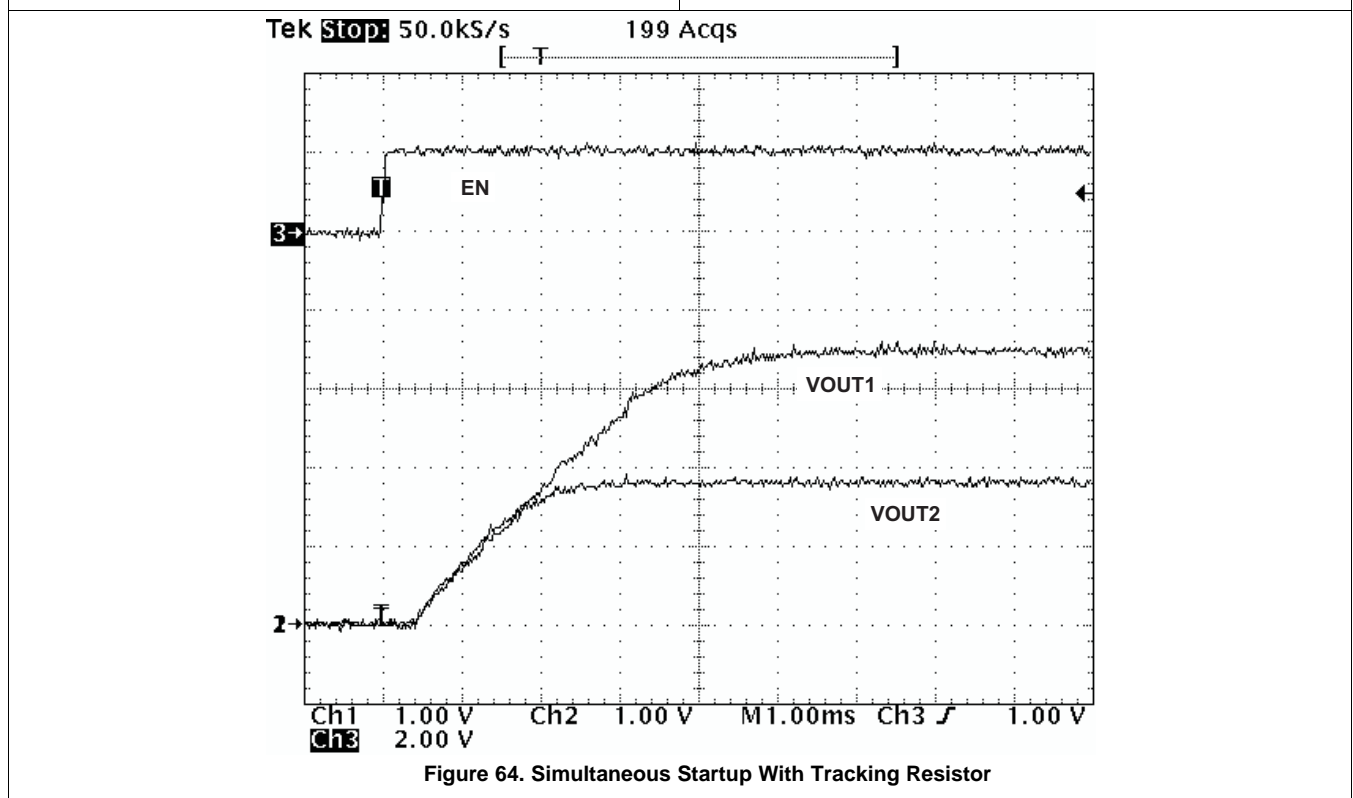

Figure 64. Simultaneous Startup With Tracking Resistor

## 10 Layout

### 10.1 Layout Guidelines

Layout is a critical portion of good power supply design. There are several signals paths that conduct fast changing currents or voltages that can interact with stray inductance or parasitic capacitance to generate noise or degrade the power supplies performance. To help eliminate these problems, the VIN pin should be bypassed to ground with a low ESR ceramic bypass capacitor with X5R or X7R dielectric. Care should be taken to minimize the loop area formed by the bypass capacitor connections, the VIN pin, and the anode of the catch diode. See Figure 65 for a PCB layout example. The GND pin should be tied directly to the power pad under the IC and the power pad.

The power pad should be connected to any internal PCB ground planes using multiple vias directly under the IC. The PH pin should be routed to the cathode of the catch diode and to the output inductor. Since the PH connection is the switching node, the catch diode and output inductor should be located very close to the PH pins, and the area of the PCB conductor minimized to prevent excessive capacitive coupling. For operation at full rated load, the top side ground area must provide adequate heat dissipating area. The RT/CLK pin is sensitive to noise so the RT resistor should be located as close as possible to the IC and routed with minimal lengths of trace. The additional external components can be placed approximately as shown. It may be possible to obtain acceptable performance with alternate PCB layouts, however this layout has been shown to produce good results and is meant as a guideline.

### 10.2 Layout Example

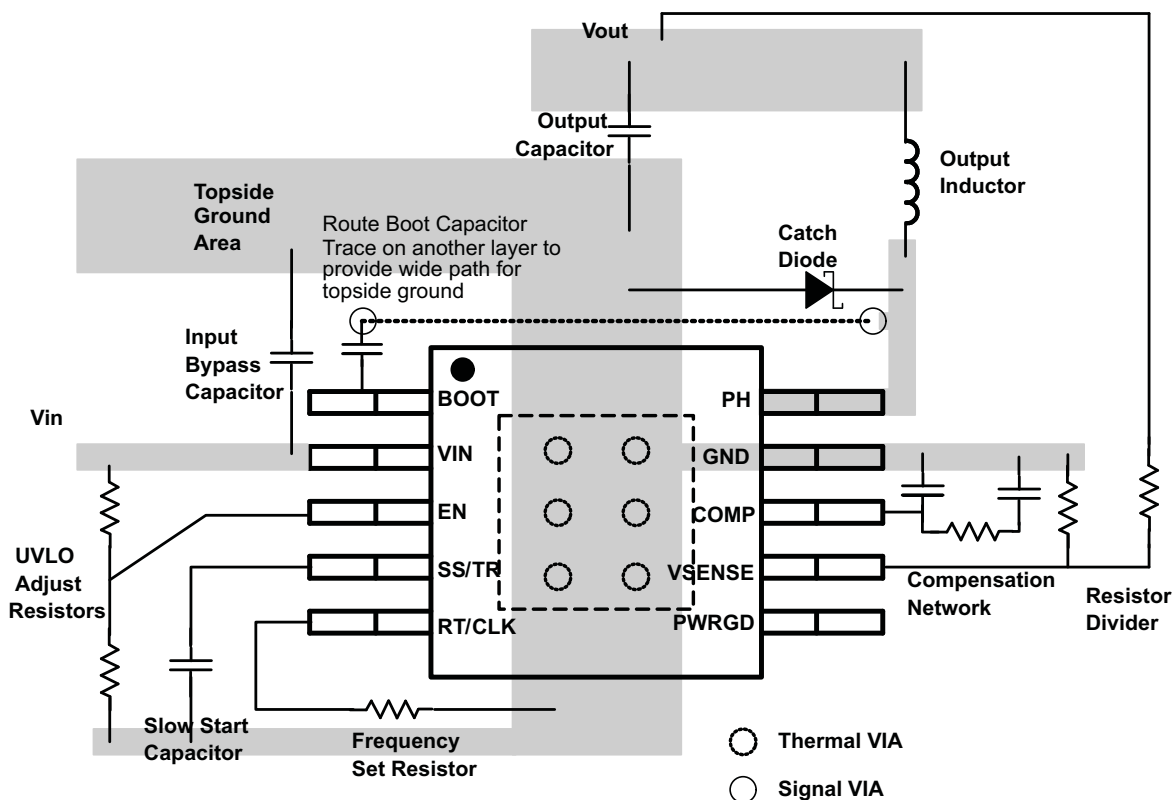

Figure 65. PCB Layout Example

### 10.3 Power Dissipation Estimate

The following formulas show how to estimate the device power dissipation under continuous conduction mode (CCM) operation. These equations should not be used if the device is working in discontinuous conduction mode (DCM).

### Power Dissipation Estimate (continued)

The power dissipation of the device includes conduction loss ( $P_{\text{con}}$ ), switching loss ( $P_{\text{sw}}$ ), gate drive loss ( $P_{\text{gd}}$ ) and supply current ( $P_{\text{q}}$ ).

$$P_{\text{COND}} = (I_{\text{OUT}})^2 \times R_{\text{DS(on)}} \times \left( \frac{V_{\text{OUT}}}{V_{\text{IN}}} \right) \quad (54)$$

$$P_{\text{SW}} = (V_{\text{IN}})^2 \times f_{\text{SW}} \times I_{\text{OUT}} \times 0.25 \times 10^{-9} \quad (55)$$

$$P_{\text{GD}} = V_{\text{IN}} \times 3 \times 10^{-9} \times f_{\text{SW}} \quad (56)$$

$$P_{\text{Q}} = 116 \times 10^{-6} \times V_{\text{IN}}$$

where

- $I_{\text{OUT}}$  is the output current (A)
- $R_{\text{DS(on)}}$  is the on-resistance of the high-side MOSFET ( $\Omega$ )
- $V_{\text{OUT}}$  is the output voltage (V)
- $V_{\text{IN}}$  is the input voltage (V)
- $f_{\text{SW}}$  is the switching frequency (Hz) (57)

$$P_{\text{TOT}} = P_{\text{COND}} \times P_{\text{SW}} \times P_{\text{GD}} \times P_{\text{Q}} \quad (58)$$

For given  $T_{\text{A}}$ ,

$$T_{\text{J}} = T_{\text{A}} + R_{\text{TH}} \times P_{\text{TOT}} \quad (59)$$

For given  $T_{\text{JMAX}} = 150^{\circ}\text{C}$

$$T_{\text{A(max)}} = T_{\text{J(max)}} - R_{\text{TH}} \times P_{\text{TOT}}$$

where

- $P_{\text{TOT}}$  is the total device power dissipation (W)
- $T_{\text{A}}$  is the ambient temperature ( $^{\circ}\text{C}$ )
- $T_{\text{J}}$  is the junction temperature ( $^{\circ}\text{C}$ )
- $R_{\text{TH}}$  is the thermal resistance of the package ( $^{\circ}\text{C}/\text{W}$ )
- $T_{\text{J(max)}}$  is maximum junction temperature ( $^{\circ}\text{C}$ )
- $T_{\text{A(max)}}$  is maximum ambient temperature ( $^{\circ}\text{C}$ ). (60)

There are additional power losses in the regulator circuit due to the inductor ac and dc losses, the catch diode and trace resistance that will impact the overall efficiency of the regulator.

## 11 器件和文档支持

### 11.1 器件支持

#### 11.1.1 Third-Party Products Disclaimer

TI'S PUBLICATION OF INFORMATION REGARDING THIRD-PARTY PRODUCTS OR SERVICES DOES NOT CONSTITUTE AN ENDORSEMENT REGARDING THE SUITABILITY OF SUCH PRODUCTS OR SERVICES OR A WARRANTY, REPRESENTATION OR ENDORSEMENT OF SUCH PRODUCTS OR SERVICES, EITHER ALONE OR IN COMBINATION WITH ANY TI PRODUCT OR SERVICE.

### 11.2 社区资源

The following links connect to TI community resources. Linked contents are provided "AS IS" by the respective contributors. They do not constitute TI specifications and do not necessarily reflect TI's views; see TI's [Terms of Use](#).

**TI E2E™ Online Community** *TI's Engineer-to-Engineer (E2E) Community*. Created to foster collaboration among engineers. At [e2e.ti.com](http://e2e.ti.com), you can ask questions, share knowledge, explore ideas and help solve problems with fellow engineers.

**Design Support** *TI's Design Support* Quickly find helpful E2E forums along with design support tools and contact information for technical support.

### 11.3 商标

Eco-mode, 封装, SwitcherPro, E2E are trademarks of Texas Instruments.  
WEBENCH is a registered trademark of Texas Instruments.  
All other trademarks are the property of their respective owners.

### 11.4 静电放电警告



这些装置包含有限的内置 ESD 保护。存储或装卸时，应将导线一起截短或将装置放置于导电泡棉中，以防止 MOS 门极遭受静电损伤。

### 11.5 Glossary

**SLYZ022** — *TI Glossary*.

This glossary lists and explains terms, acronyms, and definitions.

## 12 机械、封装和可订购信息

以下页中包括机械、封装和可订购信息。这些信息是针对指定器件可提供的最新数据。这些数据会在无通知且不对本文档进行修订的情况下发生改变。欲获得该数据表的浏览器版本，请查阅左侧的导航栏。

**PACKAGING INFORMATION**

Orderable part number	Status (1)	Material type (2)	Package   Pins	Package qty   Carrier	RoHS (3)	Lead finish/ Ball material (4)	MSL rating/ Peak reflow (5)	Op temp (°C)	Part marking (6)
<a href="#">TPS54140ADGQ</a>	Active	Production	HVSSOP (DGQ)   10	80   TUBE	Yes	NIPDAUAG	Level-1-260C-UNLIM	-40 to 125	5414A
TPS54140ADGQ.A	Active	Production	HVSSOP (DGQ)   10	80   TUBE	Yes	NIPDAUAG	Level-1-260C-UNLIM	-40 to 125	5414A
TPS54140ADGQ.B	Active	Production	HVSSOP (DGQ)   10	80   TUBE	Yes	NIPDAUAG	Level-1-260C-UNLIM	-40 to 125	5414A
<a href="#">TPS54140ADGQR</a>	Active	Production	HVSSOP (DGQ)   10	2500   LARGE T&R	Yes	NIPDAU   NIPDAUAG	Level-1-260C-UNLIM	-40 to 125	5414A
TPS54140ADGQR.A	Active	Production	HVSSOP (DGQ)   10	2500   LARGE T&R	Yes	NIPDAU	Level-1-260C-UNLIM	-40 to 125	5414A
TPS54140ADGQR.B	Active	Production	HVSSOP (DGQ)   10	2500   LARGE T&R	Yes	NIPDAU	Level-1-260C-UNLIM	-40 to 125	5414A
TPS54140ADGQRG4	Active	Production	HVSSOP (DGQ)   10	2500   LARGE T&R	Yes	NIPDAU	Level-1-260C-UNLIM	-40 to 125	5414A
TPS54140ADGQRG4.A	Active	Production	HVSSOP (DGQ)   10	2500   LARGE T&R	Yes	NIPDAU	Level-1-260C-UNLIM	-40 to 125	5414A
TPS54140ADGQRG4.B	Active	Production	HVSSOP (DGQ)   10	2500   LARGE T&R	Yes	NIPDAU	Level-1-260C-UNLIM	-40 to 125	5414A
<a href="#">TPS54140ADRCR</a>	Active	Production	VSON (DRC)   10	3000   LARGE T&R	Yes	NIPDAU   NIPDAUAG	Level-1-260C-UNLIM	-40 to 125	5414A
TPS54140ADRCR.A	Active	Production	VSON (DRC)   10	3000   LARGE T&R	Yes	NIPDAU	Level-1-260C-UNLIM	-40 to 125	5414A
TPS54140ADRCR.B	Active	Production	VSON (DRC)   10	3000   LARGE T&R	Yes	NIPDAU	Level-1-260C-UNLIM	-40 to 125	5414A
TPS54140ADRCRG4	Active	Production	VSON (DRC)   10	3000   LARGE T&R	Yes	NIPDAU	Level-1-260C-UNLIM	-40 to 125	5414A
TPS54140ADRCRG4.A	Active	Production	VSON (DRC)   10	3000   LARGE T&R	Yes	NIPDAU	Level-1-260C-UNLIM	-40 to 125	5414A
TPS54140ADRCRG4.B	Active	Production	VSON (DRC)   10	3000   LARGE T&R	Yes	NIPDAU	Level-1-260C-UNLIM	-40 to 125	5414A
<a href="#">TPS54140ADRCT</a>	Active	Production	VSON (DRC)   10	250   SMALL T&R	Yes	NIPDAU   NIPDAUAG	Level-1-260C-UNLIM	-40 to 125	5414A
TPS54140ADRCT.A	Active	Production	VSON (DRC)   10	250   SMALL T&R	Yes	NIPDAU	Level-1-260C-UNLIM	-40 to 125	5414A
TPS54140ADRCT.B	Active	Production	VSON (DRC)   10	250   SMALL T&R	Yes	NIPDAU	Level-1-260C-UNLIM	-40 to 125	5414A

(1) **Status:** For more details on status, see our [product life cycle](#).

(2) **Material type:** When designated, preproduction parts are prototypes/experimental devices, and are not yet approved or released for full production. Testing and final process, including without limitation quality assurance, reliability performance testing, and/or process qualification, may not yet be complete, and this item is subject to further changes or possible discontinuation. If available for ordering, purchases will be subject to an additional waiver at checkout, and are intended for early internal evaluation purposes only. These items are sold without warranties of any kind.

(3) **RoHS values:** Yes, No, RoHS Exempt. See the [TI RoHS Statement](#) for additional information and value definition.

(4) **Lead finish/Ball material:** Parts may have multiple material finish options. Finish options are separated by a vertical ruled line. Lead finish/Ball material values may wrap to two lines if the finish value exceeds the maximum column width.

(5) **MSL rating/Peak reflow:** The moisture sensitivity level ratings and peak solder (reflow) temperatures. In the event that a part has multiple moisture sensitivity ratings, only the lowest level per JEDEC standards is shown. Refer to the shipping label for the actual reflow temperature that will be used to mount the part to the printed circuit board.

(6) **Part marking:** There may be an additional marking, which relates to the logo, the lot trace code information, or the environmental category of the part.

Multiple part markings will be inside parentheses. Only one part marking contained in parentheses and separated by a "~" will appear on a part. If a line is indented then it is a continuation of the previous line and the two combined represent the entire part marking for that device.

**Important Information and Disclaimer:**The information provided on this page represents TI's knowledge and belief as of the date that it is provided. TI bases its knowledge and belief on information provided by third parties, and makes no representation or warranty as to the accuracy of such information. Efforts are underway to better integrate information from third parties. TI has taken and continues to take reasonable steps to provide representative and accurate information but may not have conducted destructive testing or chemical analysis on incoming materials and chemicals. TI and TI suppliers consider certain information to be proprietary, and thus CAS numbers and other limited information may not be available for release.

In no event shall TI's liability arising out of such information exceed the total purchase price of the TI part(s) at issue in this document sold by TI to Customer on an annual basis.

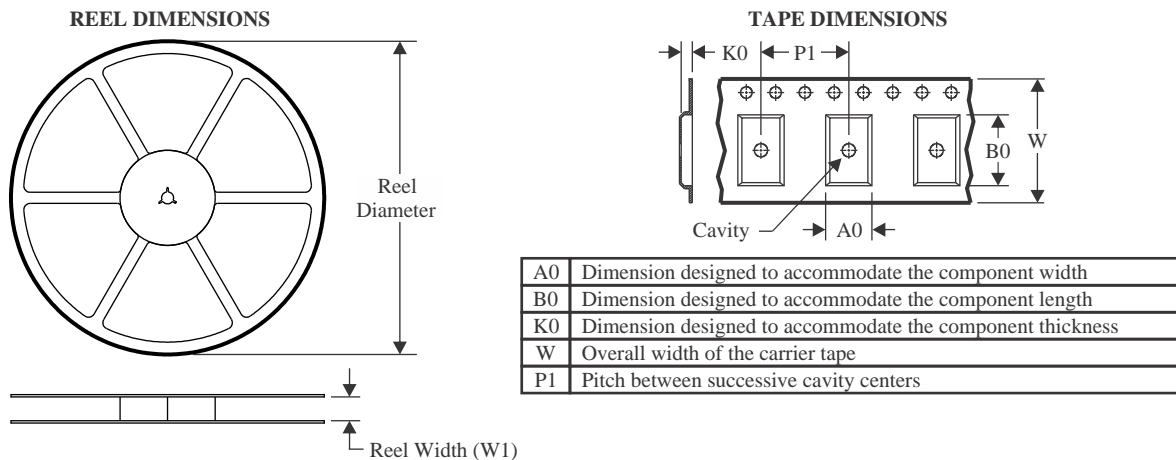
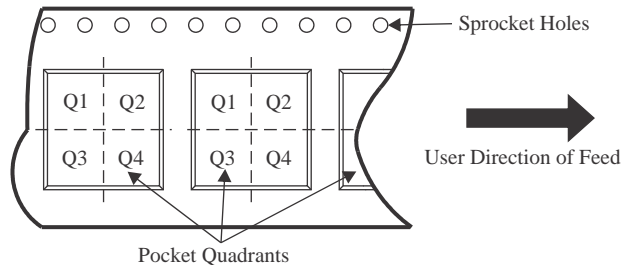
**TAPE AND REEL INFORMATION**

**QUADRANT ASSIGNMENTS FOR PIN 1 ORIENTATION IN TAPE**

\*All dimensions are nominal

Device	Package Type	Package Drawing	Pins	SPQ	Reel Diameter (mm)	Reel Width W1 (mm)	A0 (mm)	B0 (mm)	K0 (mm)	P1 (mm)	W (mm)	Pin1 Quadrant
TPS54140ADGQR	HVSSOP	DGQ	10	2500	330.0	12.4	5.25	3.35	1.25	8.0	12.0	Q1
TPS54140ADGQRG4	HVSSOP	DGQ	10	2500	330.0	12.4	5.25	3.35	1.25	8.0	12.0	Q1
TPS54140ADRCR	VSON	DRC	10	3000	330.0	12.4	3.3	3.3	1.1	8.0	12.0	Q2
TPS54140ADRCRG4	VSON	DRC	10	3000	330.0	12.4	3.3	3.3	1.1	8.0	12.0	Q2
TPS54140ADRCT	VSON	DRC	10	250	180.0	12.4	3.3	3.3	1.0	8.0	12.0	Q2
TPS54140ADRCT	VSON	DRC	10	250	330.0	12.4	3.3	3.3	1.1	8.0	12.0	Q2
TPS54140ADRCT	VSON	DRC	10	250	180.0	12.4	3.3	3.3	1.1	8.0	12.0	Q2

**TAPE AND REEL BOX DIMENSIONS**

\*All dimensions are nominal

Device	Package Type	Package Drawing	Pins	SPQ	Length (mm)	Width (mm)	Height (mm)
TPS54140ADGQR	HVSSOP	DGQ	10	2500	366.0	364.0	50.0
TPS54140ADGQRG4	HVSSOP	DGQ	10	2500	366.0	364.0	50.0
TPS54140ADRCR	VSON	DRC	10	3000	367.0	367.0	35.0
TPS54140ADRCRG4	VSON	DRC	10	3000	367.0	367.0	35.0
TPS54140ADRCT	VSON	DRC	10	250	200.0	183.0	25.0
TPS54140ADRCT	VSON	DRC	10	250	338.0	355.0	35.0
TPS54140ADRCT	VSON	DRC	10	250	210.0	185.0	35.0

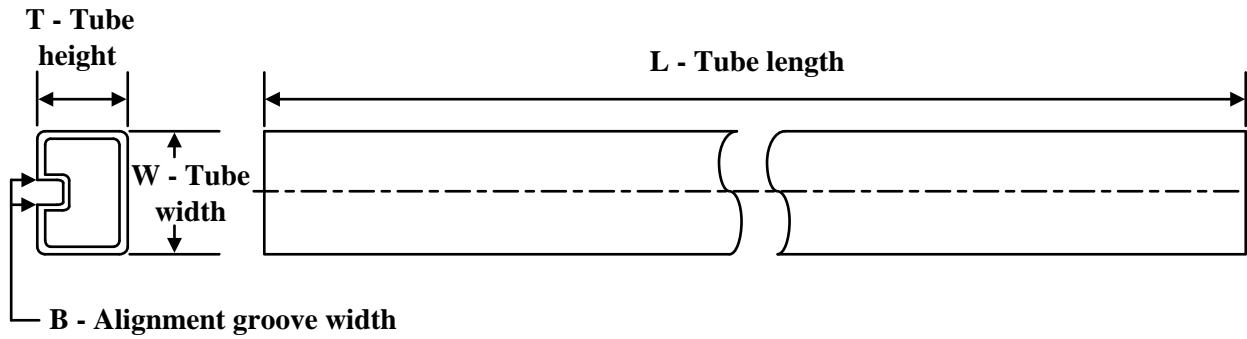
**TUBE**

\*All dimensions are nominal

Device	Package Name	Package Type	Pins	SPQ	L (mm)	W (mm)	T (μm)	B (mm)
TPS54140ADGQ	DGQ	HVSSOP	10	80	330	6.55	500	2.88
TPS54140ADGQ	DGQ	HVSSOP	10	80	322	6.55	1000	3.01
TPS54140ADGQ.A	DGQ	HVSSOP	10	80	322	6.55	1000	3.01
TPS54140ADGQ.A	DGQ	HVSSOP	10	80	330	6.55	500	2.88
TPS54140ADGQ.B	DGQ	HVSSOP	10	80	330	6.55	500	2.88
TPS54140ADGQ.B	DGQ	HVSSOP	10	80	322	6.55	1000	3.01

## GENERIC PACKAGE VIEW

**DGQ 10**

**PowerPAD™ HVSSOP - 1.1 mm max height**

3 x 3, 0.5 mm pitch

PLASTIC SMALL OUTLINE

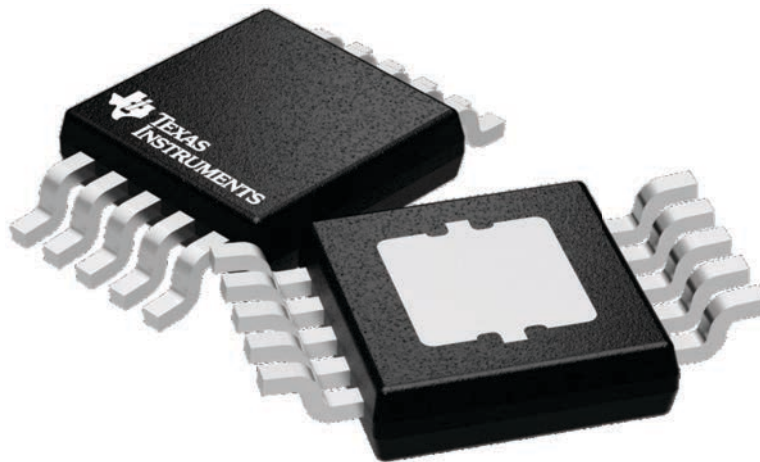

Images above are just a representation of the package family, actual package may vary.  
Refer to the product data sheet for package details.

4224775/A

# DGQ0010H

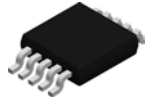

# PACKAGE OUTLINE

PowerPAD™ - 1.1 mm max height

PLASTIC SMALL OUTLINE

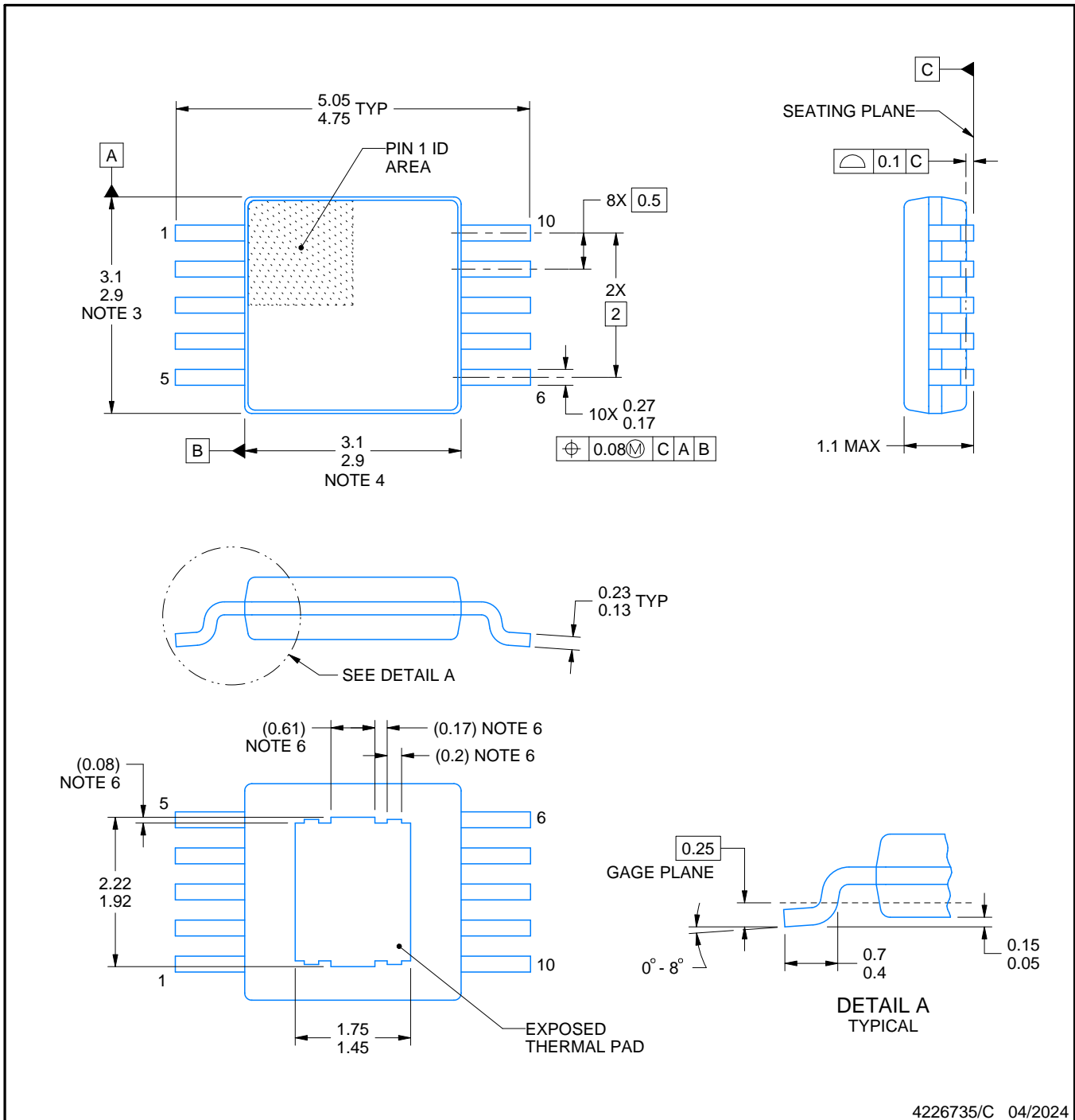

4226735/C 04/2024

PowerPAD is a trademark of Texas Instruments.

**NOTES:**

1. All linear dimensions are in millimeters. Any dimensions in parenthesis are for reference only. Dimensioning and tolerancing per ASME Y14.5M.
2. This drawing is subject to change without notice.
3. This dimension does not include mold flash, protrusions, or gate burrs. Mold flash, protrusions, or gate burrs shall not exceed 0.15 mm per side.
4. This dimension does not include interlead flash. Interlead flash shall not exceed 0.25 mm per side.
5. Reference JEDEC registration MO-187, variation BA-T.
6. Features may differ or may not be present.

# EXAMPLE BOARD LAYOUT

DGQ0010H

PowerPAD™ - 1.1 mm max height

PLASTIC SMALL OUTLINE

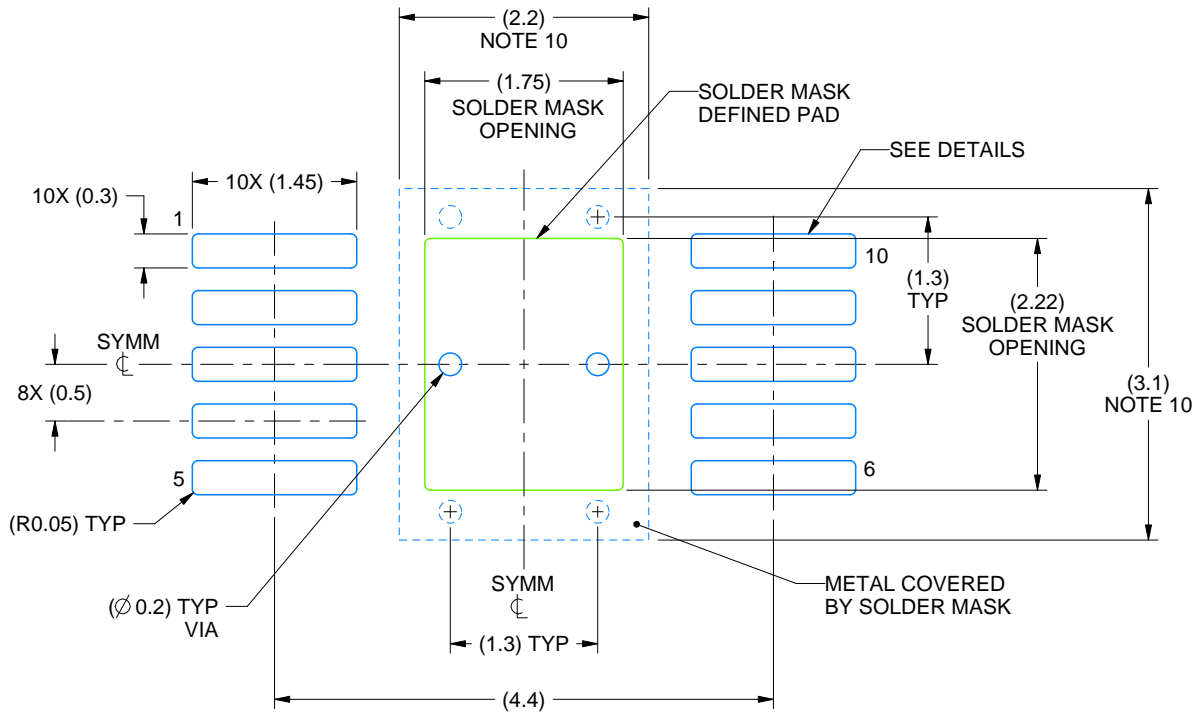

LAND PATTERN EXAMPLE  
EXPOSED METAL SHOWN  
SCALE:15X

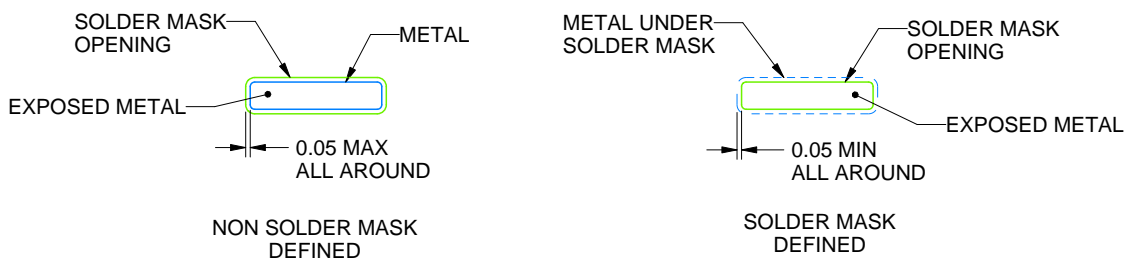

SOLDER MASK DETAILS

4226735/C 04/2024

NOTES: (continued)

7. Publication IPC-7351 may have alternate designs.
8. Solder mask tolerances between and around signal pads can vary based on board fabrication site.
9. This package is designed to be soldered to a thermal pad on the board. For more information, see Texas Instruments literature numbers SLMA002 ([www.ti.com/lit/slma002](http://www.ti.com/lit/slma002)) and SLMA004 ([www.ti.com/lit/slma004](http://www.ti.com/lit/slma004)).
10. Size of metal pad may vary due to creepage requirement.

# EXAMPLE STENCIL DESIGN

DGQ0010H

PowerPAD™ - 1.1 mm max height

PLASTIC SMALL OUTLINE

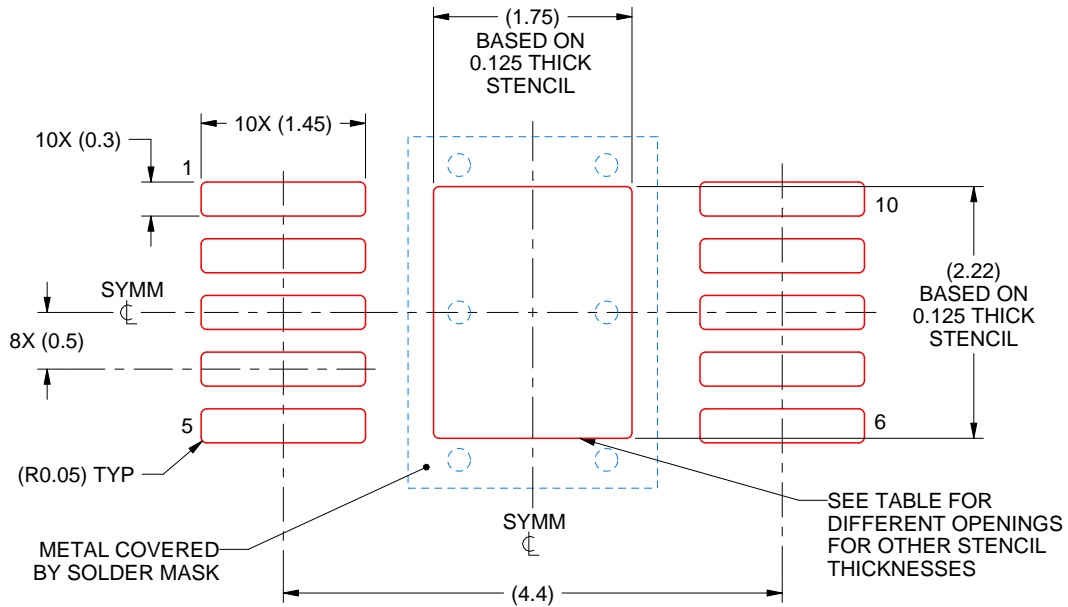

SOLDER PASTE EXAMPLE  
EXPOSED PAD  
100% PRINTED SOLDER COVERAGE BY AREA  
SCALE:15X

STENCIL THICKNESS	SOLDER STENCIL OPENING
0.100	1.96 X 2.48
0.125	1.75 X 2.22 (SHOWN)
0.150	1.6 X 2.03
0.175	1.48 X 1.88

4226735/C 04/2024

NOTES: (continued)

11. Laser cutting apertures with trapezoidal walls and rounded corners may offer better paste release. IPC-7525 may have alternate design recommendations.
12. Board assembly site may have different recommendations for stencil design.

# DGQ0010D



# PACKAGE OUTLINE

PowerPAD™ - 1.1 mm max height

PLASTIC SMALL OUTLINE

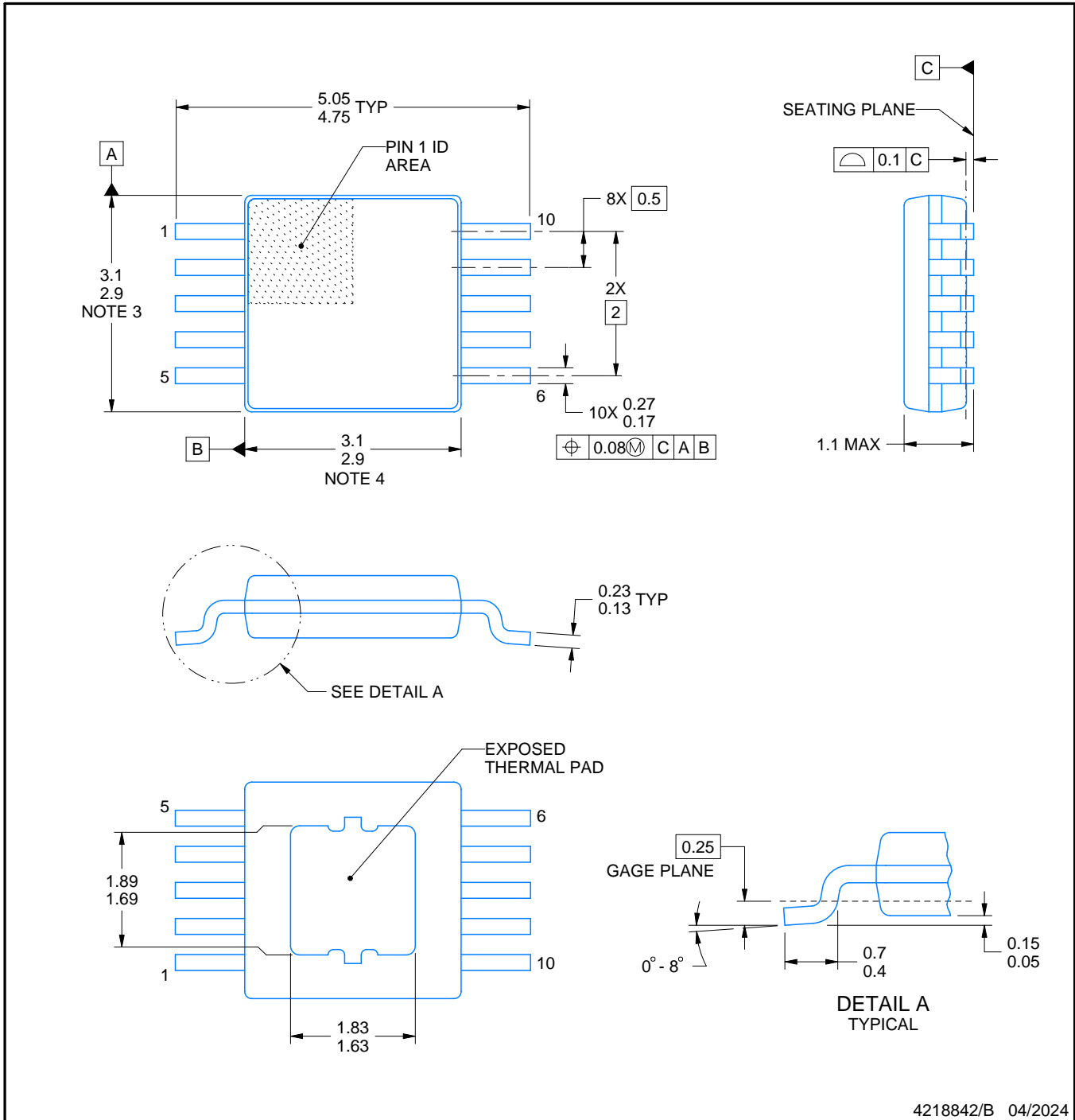

4218842/B 04/2024

PowerPAD is a trademark of Texas Instruments.

**NOTES:**

1. All linear dimensions are in millimeters. Any dimensions in parenthesis are for reference only. Dimensioning and tolerancing per ASME Y14.5M.
2. This drawing is subject to change without notice.
3. This dimension does not include mold flash, protrusions, or gate burrs. Mold flash, protrusions, or gate burrs shall not exceed 0.15 mm per side.
4. This dimension does not include interlead flash. Interlead flash shall not exceed 0.25 mm per side.
5. Reference JEDEC registration MO-187, variation BA-T.

# EXAMPLE BOARD LAYOUT

DGQ0010D

PowerPAD™ - 1.1 mm max height

PLASTIC SMALL OUTLINE

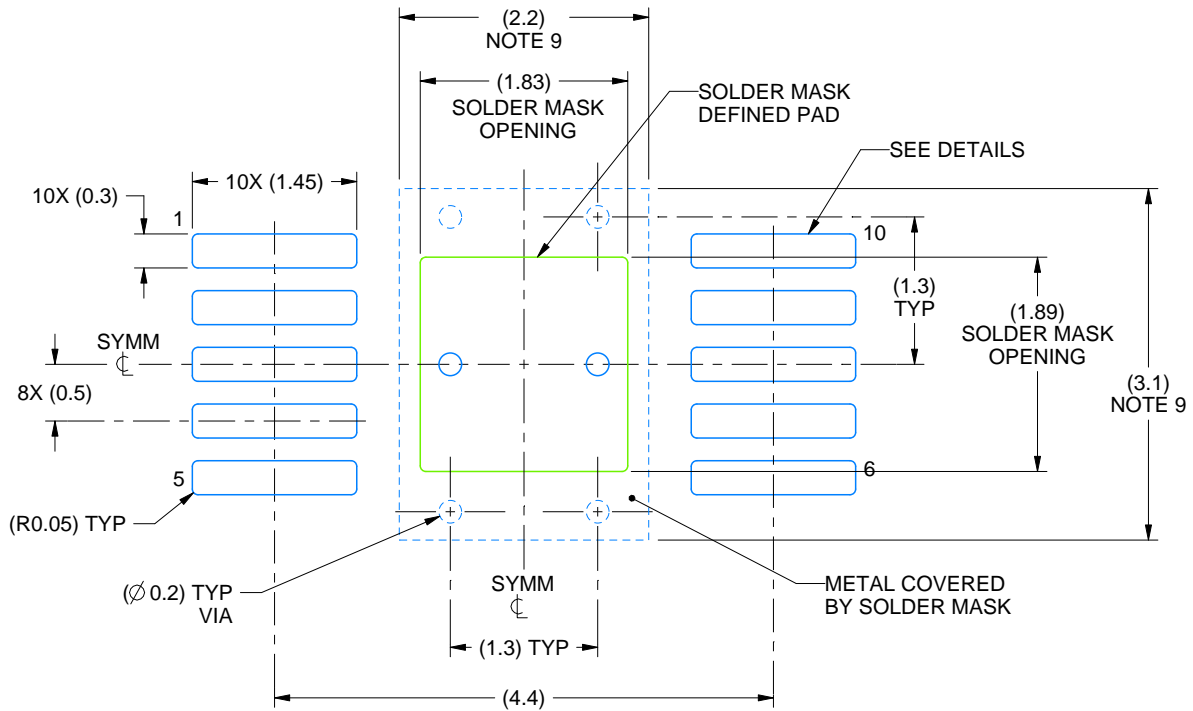

LAND PATTERN EXAMPLE  
SCALE:15X

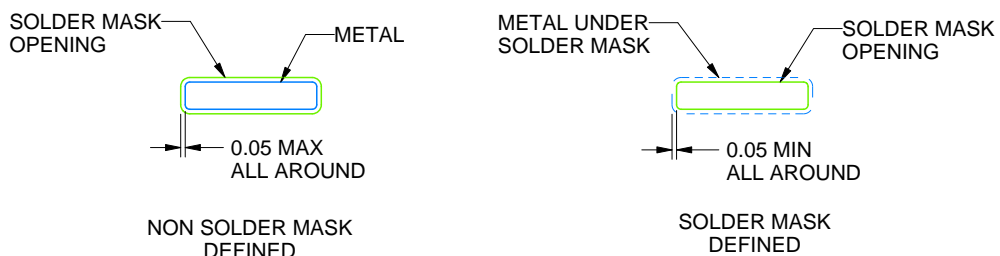

SOLDER MASK DETAILS

4218842/B 04/2024

NOTES: (continued)

6. Publication IPC-7351 may have alternate designs.
7. Solder mask tolerances between and around signal pads can vary based on board fabrication site.
8. This package is designed to be soldered to a thermal pad on the board. For more information, see Texas Instruments literature numbers SLMA002 ([www.ti.com/lit/slma002](http://www.ti.com/lit/slma002)) and SLMA004 ([www.ti.com/lit/slma004](http://www.ti.com/lit/slma004)).
9. Size of metal pad may vary due to creepage requirement.

# EXAMPLE STENCIL DESIGN

DGQ0010D

PowerPAD™ - 1.1 mm max height

PLASTIC SMALL OUTLINE

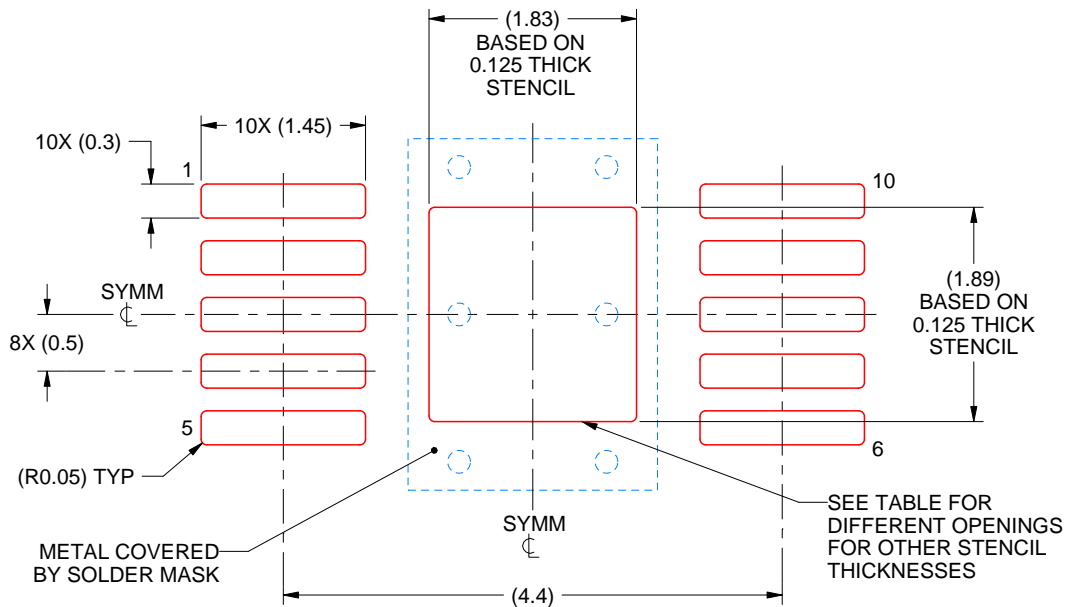

SOLDER PASTE EXAMPLE  
EXPOSED PAD  
100% PRINTED SOLDER COVERAGE BY AREA  
SCALE:15X

STENCIL THICKNESS	SOLDER STENCIL OPENING
0.1	2.05 X 2.11
0.125	1.83 X 1.89 (SHOWN)
0.150	1.67 X 1.73
0.175	1.55 X 1.60

4218842/B 04/2024

NOTES: (continued)

10. Laser cutting apertures with trapezoidal walls and rounded corners may offer better paste release. IPC-7525 may have alternate design recommendations.
11. Board assembly site may have different recommendations for stencil design.

## GENERIC PACKAGE VIEW

**DRC 10**

**VSON - 1 mm max height**

3 x 3, 0.5 mm pitch

PLASTIC SMALL OUTLINE - NO LEAD

This image is a representation of the package family, actual package may vary.  
Refer to the product data sheet for package details.

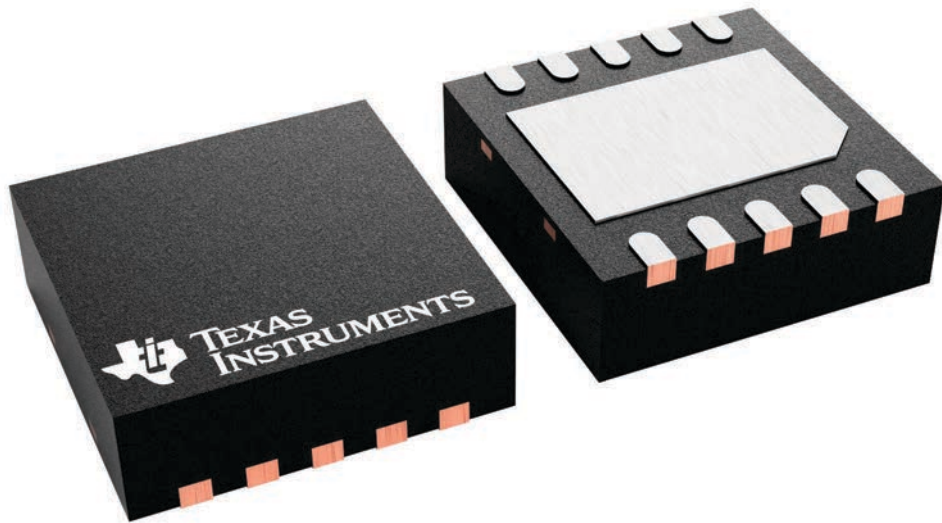

4226193/A



# EXAMPLE BOARD LAYOUT

DRC0010J

VSON - 1 mm max height

PLASTIC SMALL OUTLINE - NO LEAD

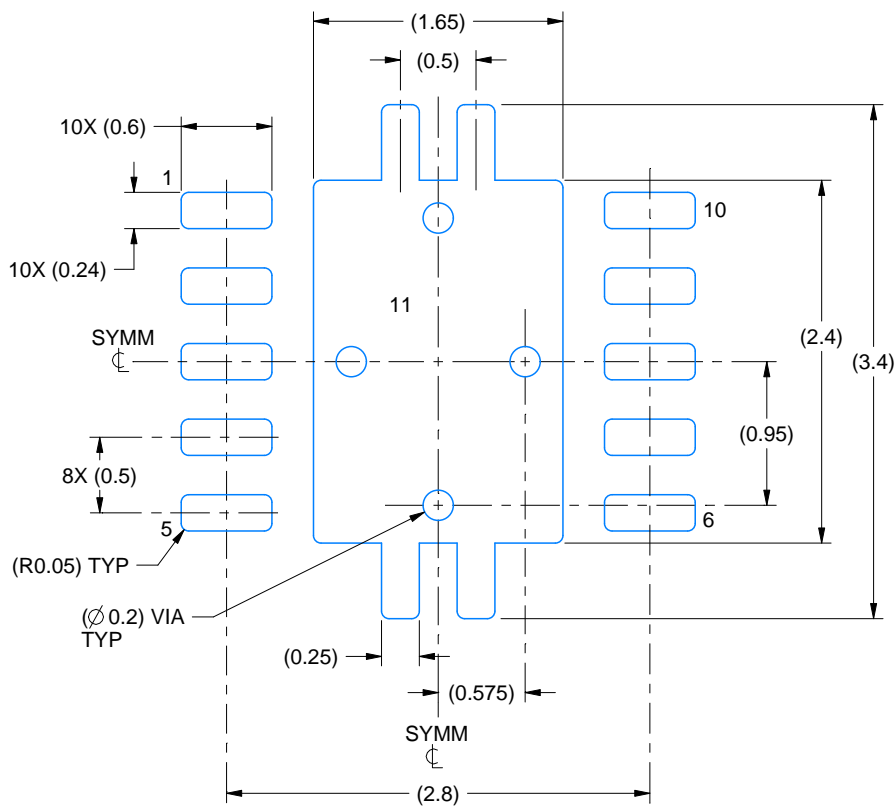

LAND PATTERN EXAMPLE  
EXPOSED METAL SHOWN  
SCALE:20X

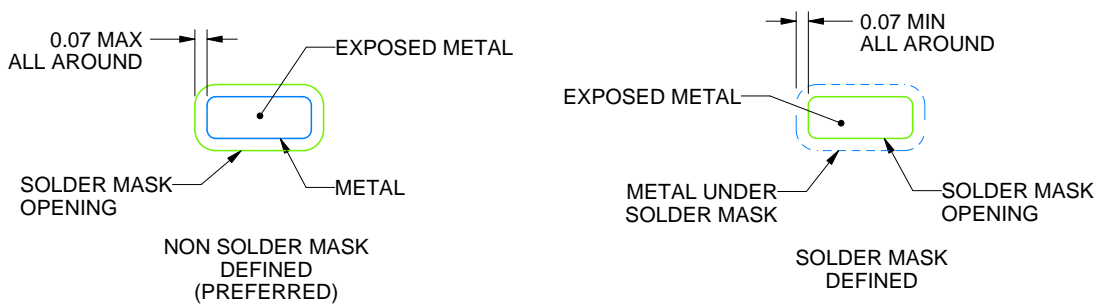

SOLDER MASK DETAILS

4218878/B 07/2018

NOTES: (continued)

4. This package is designed to be soldered to a thermal pad on the board. For more information, see Texas Instruments literature number SLUA271 ([www.ti.com/lit/sluea271](http://www.ti.com/lit/sluea271)).
5. Vias are optional depending on application, refer to device data sheet. If any vias are implemented, refer to their locations shown on this view. It is recommended that vias under paste be filled, plugged or tented.

# EXAMPLE STENCIL DESIGN

DRC0010J

VSON - 1 mm max height

PLASTIC SMALL OUTLINE - NO LEAD

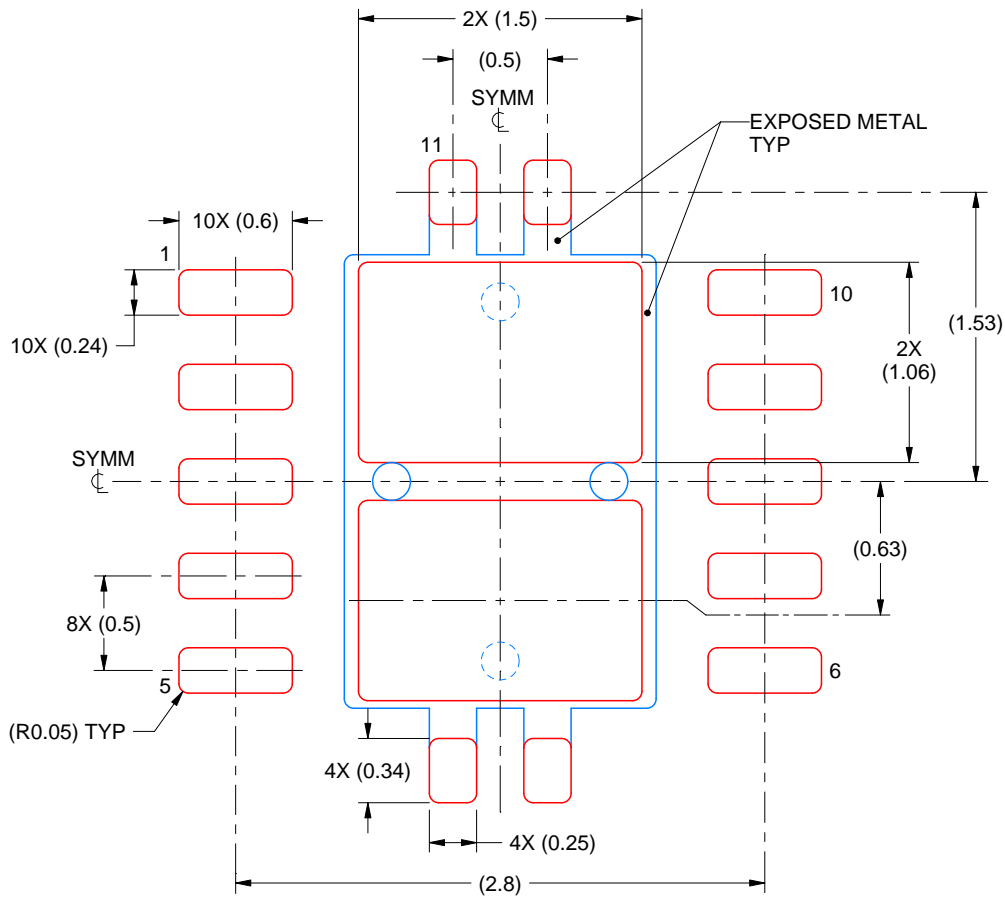

SOLDER PASTE EXAMPLE  
BASED ON 0.125 mm THICK STENCIL

EXPOSED PAD 11:  
80% PRINTED SOLDER COVERAGE BY AREA  
SCALE:25X

4218878/B 07/2018

NOTES: (continued)

6. Laser cutting apertures with trapezoidal walls and rounded corners may offer better paste release. IPC-7525 may have alternate design recommendations.

## 重要通知和免责声明

TI“按原样”提供技术和可靠性数据（包括数据表）、设计资源（包括参考设计）、应用或其他设计建议、网络工具、安全信息和其他资源，不保证没有瑕疵且不做任何明示或暗示的担保，包括但不限于对适销性、与某特定用途的适用性或不侵犯任何第三方知识产权的暗示担保。

这些资源可供使用 TI 产品进行设计的熟练开发人员使用。您将自行承担以下全部责任：(1) 针对您的应用选择合适的 TI 产品，(2) 设计、验证并测试您的应用，(3) 确保您的应用满足相应标准以及任何其他安全、安保法规或其他要求。

这些资源如有变更，恕不另行通知。TI 授权您仅可将这些资源用于研发本资源所述的 TI 产品的相关应用。严禁以其他方式对这些资源进行复制或展示。您无权使用任何其他 TI 知识产权或任何第三方知识产权。对于因您对这些资源的使用而对 TI 及其代表造成的任何索赔、损害、成本、损失和债务，您将全额赔偿，TI 对此概不负责。

TI 提供的产品受 [TI 销售条款](#)、[TI 通用质量指南](#) 或 [ti.com](#) 上其他适用条款或 TI 产品随附的其他适用条款的约束。TI 提供这些资源并不会扩展或以其他方式更改 TI 针对 TI 产品发布的适用的担保或担保免责声明。除非德州仪器 (TI) 明确将某产品指定为定制产品或客户特定产品，否则其产品均为按确定价格收入目录的标准通用器件。

TI 反对并拒绝您可能提出的任何其他或不同的条款。

版权所有 © 2026，德州仪器 (TI) 公司

最后更新日期：2025 年 10 月