

TPS51386 具有锁存 OVP/UVP、可调节软启动以及 PSM/OOA 模式的 4.5V 至 24V 输入、8A 同步降压转换器

1 特性

- 4.5V 至 24V 输入电压范围
- 0.6V 至 5.5V 输出电压范围
- 集成式 22mΩ 和 11mΩ MOSFET
- 支持 8A 持续 I_{OUT}
- 84μA 低静态电流
- 25°C 时基准电压 (0.6V) 精度为 ±1%
- 在 -40°C 至 125°C 温度范围内基准电压 (0.6V) 精度为 ±1.5%
- 600kHz 开关频率
- D-CAP3™ 控制模式，用于快速瞬态响应
- 支持 POSCAP 和所有 MLCC 输出电容器
- 可调节软启动和内部 1ms 软启动
- 具有在轻负载条件下可选的 PSM 和 Out-of-Audio™ (OOA) 模式，支持动态更改
- 支持大负荷运行
- 电源正常状态指示器，可监测输出电压
- 锁存输出 OV 和 UV 保护
- 非锁存 UVLO 和 OT 保护
- 逐周期过流保护
- 内置输出放电功能
- 小型 2.00mm × 3.00mm HotRod™ QFN 封装

2 应用

- 笔记本电脑和台式机
- 超极本、平板电脑
- 电视和 STB、负载点 (POL)
- 分布式电源系统

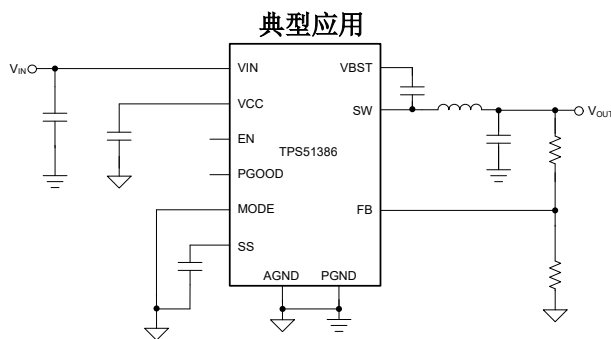

3 说明

TPS51386 是具有自适应导通时间 D-CAP3 控制模式的单片 8A 同步降压转换器。该器件集成了低 R_{DS(on)} 功率 MOSFET，因此简单易用且高效，具有极少的外部元件，适用于空间受限的电源系统。其特性包括精确的基准电压、快速负载瞬态响应、用于提高轻负载效率的自动跳跃模式运行、开关频率大于 25kHz 的 OOA 轻负载运行、具有良好线路和负载调节的 D-CAP3 控制模式，并且无需外部补偿。

TPS51386 提供 OVP、UVP、OCP、OTP 和 UVLO 的全面保护。该器件结合了电源正常信号和输出放电功能。

TPS51386 同时支持内部和外部软启动时间选项。该器件具有 1ms 的内部固定软启动时间。如果应用需要更长的软启动时间，则可以使用外部 SS 引脚，通过连接外部电容器来实现更长的软启动时间。

TPS51386 采用热增强型 12 引脚 QFN 封装，并且额定结温范围为 -40°C 至 125°C。

封装信息

器件型号	封装 ⁽¹⁾	封装尺寸 ⁽²⁾
TPS51386	RJN (VQFN-HR, 12)	2.00mm x 3.00mm

(1) 如需了解所有可用封装，请参阅数据表末尾的可订购产品附录。

(2) 封装尺寸 (长 × 宽) 为标称值，并包括引脚 (如适用)。

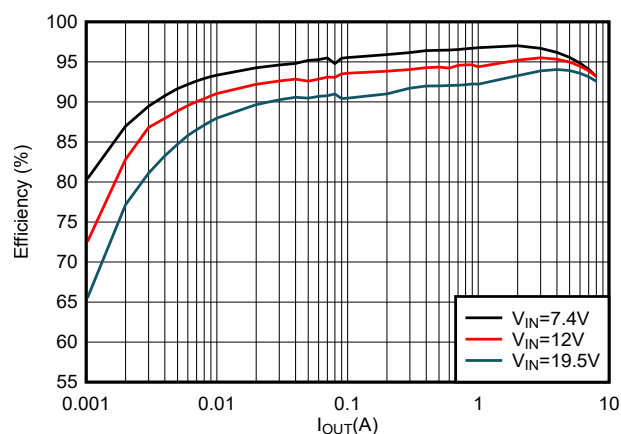

效率曲线，V_{OUT} = 5.1V，PSM 模式



Table of Contents

1 特性	1	7.4 Device Functional Modes.....	12
2 应用	1	8 Application and Implementation	14
3 说明	1	8.1 Application Information.....	14
4 Revision History	2	8.2 Typical Application.....	14
5 Pin Configuration and Functions	3	8.3 Power Supply Recommendations.....	18
6 Specifications	4	8.4 Layout.....	19
6.1 Absolute Maximum Ratings.....	4	9 Device and Documentation Support	20
6.2 ESD Ratings.....	4	9.1 Device Support.....	20
6.3 Recommended Operating Conditions.....	4	9.2 接收文档更新通知.....	20
6.4 Thermal Information.....	4	9.3 支持资源.....	20
6.5 Electrical Characteristics.....	5	9.4 Trademarks.....	20
6.6 Typical Characteristics.....	7	9.5 静电放电警告.....	20
7 Detailed Description	9	9.6 术语表.....	20
7.1 Overview.....	9	10 Mechanical, Packaging, and Orderable Information	21
7.2 Functional Block Diagram.....	10		
7.3 Feature Description.....	10		

4 Revision History

DATE	REVISION	NOTES
August 2023	*	Initial release

5 Pin Configuration and Functions



图 5-1. RJN Package 12-Pin VQFN-HR Top View

表 5-1. Pin Functions

PIN		I/O	DESCRIPTION
NAME	NO.		
VIN	1	P	Input voltage supply pin for the control circuitry. Connect the input decoupling capacitors between VIN and PGND.
PGND	2	G	Power ground terminal for the internal power FET.
PG	3	O	Open Drain Power-Good Indicator. This pin is asserted low if output voltage is out of PG threshold, overvoltage or if the device is under thermal shutdown, EN shutdown or during soft start.
FB	4	I	TPS51386 uses FB pin to regulate output voltage via feedback resistor divider network.
SS	5	O	Soft-start time selection pin for TPS51386. Connecting an external capacitor sets the soft-start time and if no external capacitor is connected, the soft-start time is approximately 1 ms.
NC	6	-	No connect pin
SW	7	O	Switch node terminal. Connect the output inductor to this pin.
VBST	8	I	Supply input for the high-side MOSFET gate drive. Connect the bootstrap capacitor between VBST and SW.
VCC	9	O	5-V internal VCC LDO output. This pin supplies voltage to the internal circuitry and gate driver. Bypass this pin with a 1- μ F capacitor.
AGND	10	G	Ground of internal analog circuitry. Connect AGND to PGND at a single point close to AGND.
EN	11	I	Enable pin of buck converter. EN pin is a digital input pin, pull up to enable the converter, pull down to disable. Internal pulldown if EN pin is floating.
MODE	12	I	Mode selection pin. Connect MODE pin to VCC, or pull above 0.8 V for OOA mode operation, connect MODE to AGND or float for Power Save Mode. Internal pulldown if MODE pin is floating.

6 Specifications

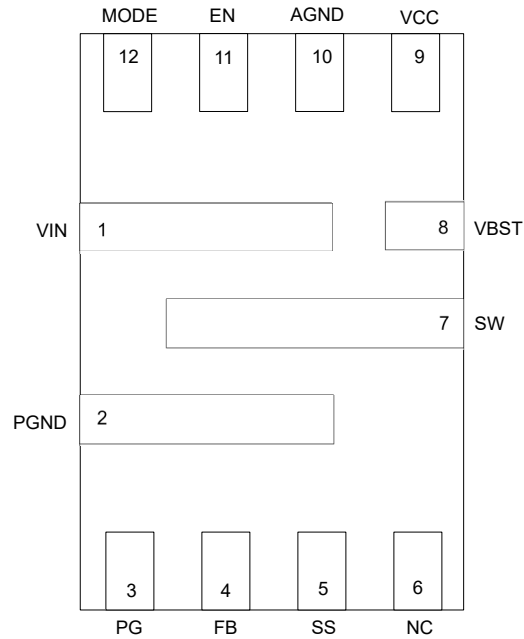
6.1 Absolute Maximum Ratings

Over operating junction temperature range (unless otherwise noted) ⁽¹⁾

		MIN	MAX	UNIT
Input voltage	VIN	- 0.3	28	V
Input voltage	VBST	- 0.3	34	
Input voltage	VBST - SW	- 0.3	6	V
Input voltage	EN, FB, MODE, SS	- 0.3	6	V
Output voltage	SW (10ns transient)	- 4	28	
Output voltage	SW	- 1.0	28	V
Output voltage	PG	- 0.3	6	V
Output voltage	VCC	- 0.3	6	V
Voltage	PGND, AGND	- 0.3	0.3	V
T _J	Operating junction temperature	- 40	150	°C
T _{stg}	Storage temperature	- 55	150	°C

- (1) Operation outside the Absolute Maximum Ratings may cause permanent device damage. Absolute Maximum Ratings do not imply functional operation of the device at these or any other conditions beyond those listed under Recommended Operating Conditions. If used outside the Recommended Operating Conditions but within the Absolute Maximum Ratings, the device may not be fully functional, and this may affect device reliability, functionality, performance, and shorten the device lifetime.

6.2 ESD Ratings

			VALUE	UNIT
V _(ESD)	Electrostatic discharge	Human-body model (HBM), per ANSI/ESDA/JEDEC JS-001 ⁽¹⁾	±2000	V
		Charged device model (CDM), per ANSI/ESDA/JEDEC JS-002 ⁽²⁾	±500	

- (1) JEDEC document JEP155 states that 500-V HBM allows safe manufacturing with a standard ESD control process.
(2) JEDEC document JEP157 states that 250-V CDM allows safe manufacturing with a standard ESD control process.

6.3 Recommended Operating Conditions

Over operating junction temperature range (unless otherwise noted)

		MIN	NOM	MAX	UNIT
Input voltage range	VIN	4.5		24	V
Input voltage range	VBST	- 0.1		29.5	V
Input voltage range	VBST - SW	- 0.1		5.5	V
Input voltage range	EN, FB, MODE, SS	- 0.3		5.5	V
Output voltage range	SW	- 1.0		24	V
Output voltage range	PG, VCC	- 0.1		5.5	V
Output current	IOUT			8	A
T _J		- 40		125	°C

6.4 Thermal Information

THERMAL METRIC ⁽¹⁾		DEVICE		UNIT
		RJNR (QFN, JEDEC)	RJNR (QFN, TI EVM)	
		12 PINS	12 PINS	
R _{θJA}	Junction-to-ambient thermal resistance	72.7	37.2	°C/W
R _{θJC(top)}	Junction-to-case (top) thermal resistance	50.1	Not Applicable ⁽²⁾	°C/W
R _{θJB}	Junction-to-board thermal resistance	18.7	Not Applicable ⁽²⁾	°C/W
ψ _{JT}	Junction-to-top characterization parameter	1.8	3.7	°C/W

6.4 Thermal Information (continued)

THERMAL METRIC ⁽¹⁾		DEVICE		UNIT
		RJNR (QFN, JEDEC)	RJNR (QFN, TI EVM)	
		12 PINS	12 PINS	
ψ_{JB}	Junction-to-board characterization parameter	18.4	18.5	°C/W

- (1) For more information about traditional and new thermal metrics, see the [Semiconductor and IC Package Thermal Metrics](#) application report.
- (2) The thermal simulation setup is not applicable to a TI EVM layout.

6.5 Electrical Characteristics

MODE connected to AGND, $V_{EN} = 3.3V$; $T_J = -40^{\circ}C$ to $+125^{\circ}C$, Typical values are at $T_J = 25^{\circ}C$ and $V_{VIN} = 12V$ (unless otherwise noted)

PARAMETER		TEST CONDITIONS	MIN	TYP	MAX	UNIT
INPUT SUPPLY (VIN)						
VIN	Input voltage range	VIN	4.5		24	V
I _{VIN}	VIN Supply Current (Quiescent)	No load, $V_{EN} = 3.3V$, non-switching		84		μA
I _{INSDN}	VIN Shutdown Current	No load, $V_{EN} = 0V$, PG open		3.7		μA
UVLO						
V _{VCC UVLO_R}	V _{CC} Under-Voltage Lockout	V _{VCC} rising		4.2	4.42	V
V _{VCC UVLO_F}	V _{CC} Under-Voltage Lockout	V _{VCC} falling	3.65	3.85		V
V _{VCC UVLO_H}	V _{CC} Under-Voltage Lockout	Hysteresis V _{CC} voltage		350	650	mV
ENABLE (EN), MODE						
V _{EN_R}	EN Threshold High-level	V _{EN} rising		1.31	1.5	V
V _{EN_F}	EN Threshold Low-level	V _{EN} falling	1.0	1.13		V
V _{EN_H}	EN Threshold Low-level	Hysteresis		180		mV
I _{EN}	EN Pull down Current	$V_{EN} = 0.8V$	1.3	2.3		μA
V _{IL,MODE}	Low-Level Input Voltage at MODE Pin		0.4			V
V _{IH,MODE}	High-Level Input Voltage at MODE Pin				0.8	V
I _{MODE}	MODE Pull down Current	$V_{MODE} = 0.8V$	1.3	2.3	3.5	μA
VCC						
V _{VCC}	VCC Output Voltage	$V_{VIN} > 5.2V$, I _{VCC} ≤ 1 mA	4.85	5	5.15	V
FEEDBACK VOLTAGE (FB)						
V _{FB_REG}	Feedback regulation voltage	$T_J = 25^{\circ}C$	594	600	606	mV
	Feedback regulation voltage	$-40^{\circ}C \leq T_J \leq 125^{\circ}C$	591	600	609	mV
DUTY CYCLE and FREQUENCY CONTROL						
f _{sw}	Switching frequency	CCM operation		600		kHz
t _{ON(min)}	Minimum ON pulse width ⁽¹⁾	$T_J = 25^{\circ}C$		65	75	ns
t _{OFF(min)}	Minimum OFF pulse width ⁽¹⁾	$T_J = 25^{\circ}C$			190	ns
OOA FUNCTION						
t _{OOA}	OOA operation period	$V_{MODE} = V_{VCC}$		30	50	μs
SOFT-START (SS)						
t _{SS}	Internal fixed soft start		0.55	1	1.35	ms
I _{SS}	Soft Start Charge Current		4	5	6	μA
POWER SWITCHES (SW)						
R _{DSON(HS)}	High-side MOSFET on-resistance	$T_J = 25^{\circ}C$		22		mΩ
R _{DSON(LS)}	Low-side MOSFET on-resistance	$T_J = 25^{\circ}C$		11		mΩ
CURRENT LIMIT						
I _{OCL}	Low-side valley current limit	Valley current limit on LS FET	9.5	11	12.5	A
I _{NOCL}	Low-side negative current limit	Sinking current limit on LS FET, OOA operation		3.9		A
OUTPUT UNDERVOLTAGE AND OVERVOLTAGE PROTECTION						

6.5 Electrical Characteristics (continued)

MODE connected to AGND, $V_{EN} = 3.3V$; $T_J = -40^{\circ}C$ to $+125^{\circ}C$, Typical values are at $T_J = 25^{\circ}C$ and $V_{VIN} = 12V$ (unless otherwise noted)

PARAMETER		TEST CONDITIONS	MIN	TYP	MAX	UNIT
V_{OVP}	OVP Trip Threshold		117	120	123	%
t_{OVPDLY}	OVP Prop deglitch			20		μs
t_{OVPDLY}	OVP latch-off Prop deglitch			256		μs
V_{UVP}	UVP Trip Threshold		55	60	65	%
t_{UVPDLY}	UVP Prop deglitch			256		μs
POWER GOOD (PG)						
t_{PGDLY}	PG Start-Up delay	PG from low to high		500		μs
t_{PGDLY}	PG delay time when V_{FB} rising (fault)	PG from high to low		20		μs
t_{PGDLY}	PG delay time when V_{FB} falling (fault)	PG from high to low		28		μs
V_{PGTH}	PG Threshold when V_{FB} falling (fault)	V_{FB} falling (fault), percentage of V_{FB}	79	85	89	%
V_{PGTH}	PG Threshold when V_{FB} rising (good)	V_{FB} rising (good), percentage of V_{FB}	86	90	94	%
V_{PGTH}	PG Threshold when V_{FB} rising (fault)	V_{FB} rising (fault), percentage of V_{FB}	116	120	124	%
V_{PGTH}	PG Threshold when V_{FB} falling (good)	V_{FB} falling (good), percentage of V_{FB}	109	115	119	%
I_{PGMAX}	PG Sink Current	$V_{PG} = 0.5V$		50		mA
I_{PGLK}	PG Leak Current	$V_{PG} = 5.5V$			1	μA
OUTPUT DISCHARGE						
R_{DIS}	Discharge resistance	$T_J = 25^{\circ}C, V_{EN} = 0V$		160		Ω
THERMAL SHUTDOWN						
$T_{J(SD)}$	Thermal shutdown threshold ⁽¹⁾			165		$^{\circ}C$
$T_{J(HYS)}$	Thermal shutdown hysteresis ⁽¹⁾			20		$^{\circ}C$

(1) Specified by design. Not production tested

6.6 Typical Characteristics

$V_{IN} = 12\text{ V}$, $T_J = -40^\circ\text{C}$ to 125°C , unless otherwise specified.



图 6-1. Quiescent Current vs Temperature



图 6-2. Shutdown Current vs Temperature

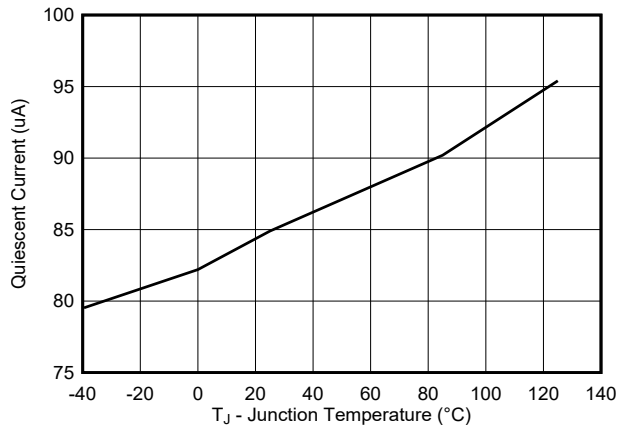

图 6-3. Voltage Reference vs Temperature

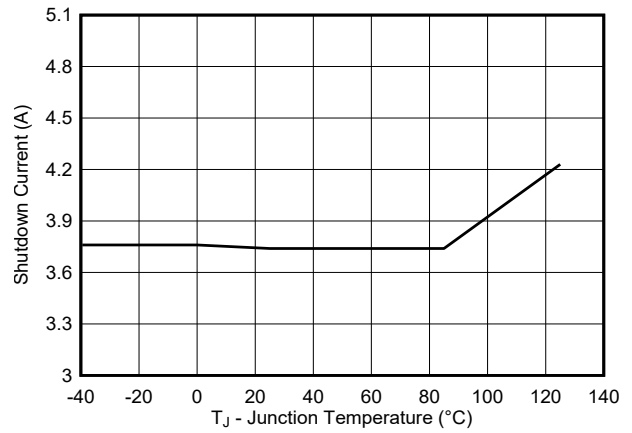

图 6-4. Enable On Voltage vs Temperature

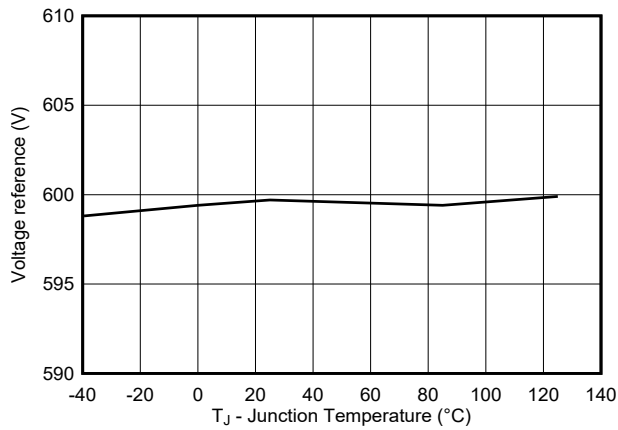

图 6-5. Enable Off Voltage vs Temperature

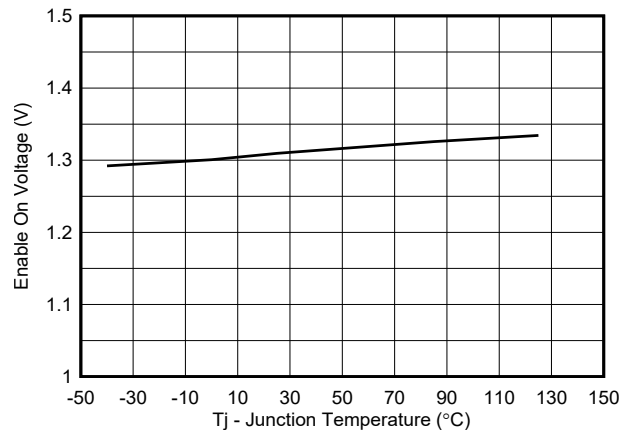

图 6-6. High-side R_{DS(on)} vs Temperature

6.6 Typical Characteristics (continued)

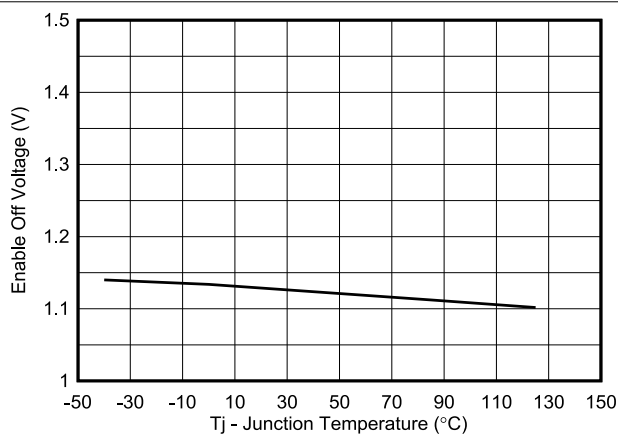
$V_{IN} = 12\text{ V}$, $T_J = -40^\circ\text{C}$ to 125°C , unless otherwise specified.

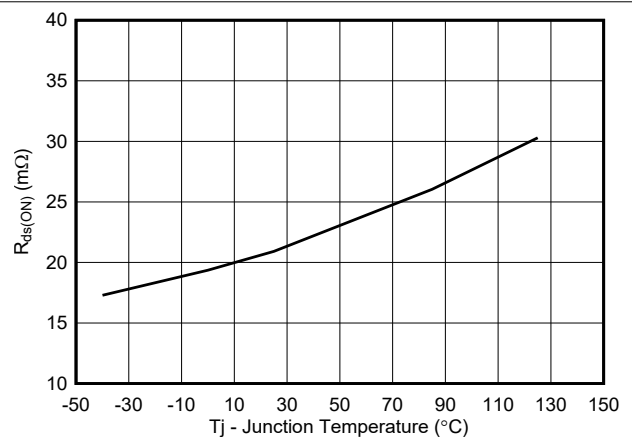
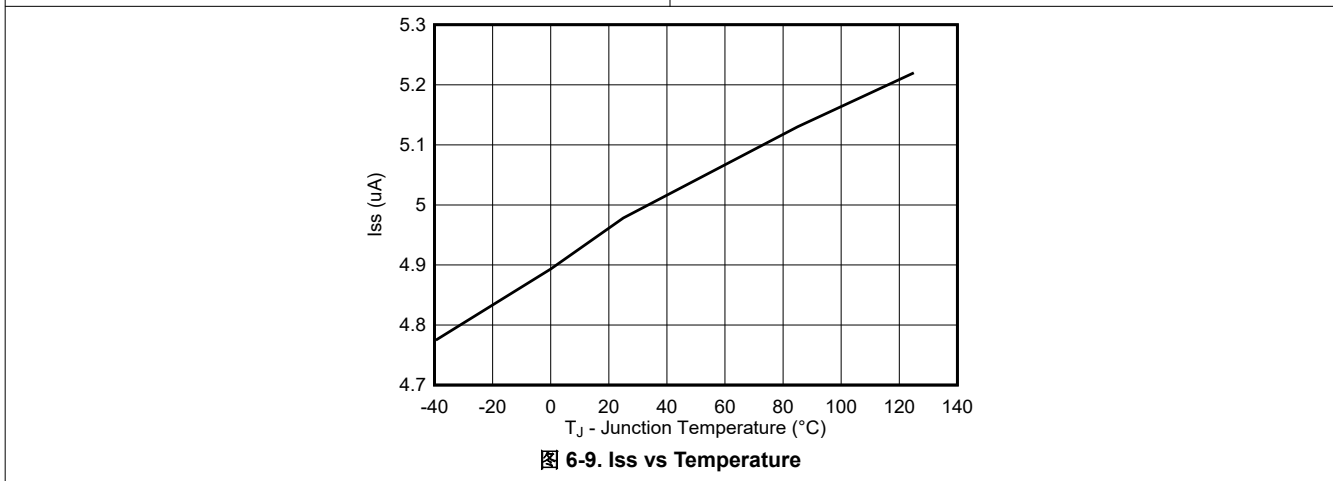
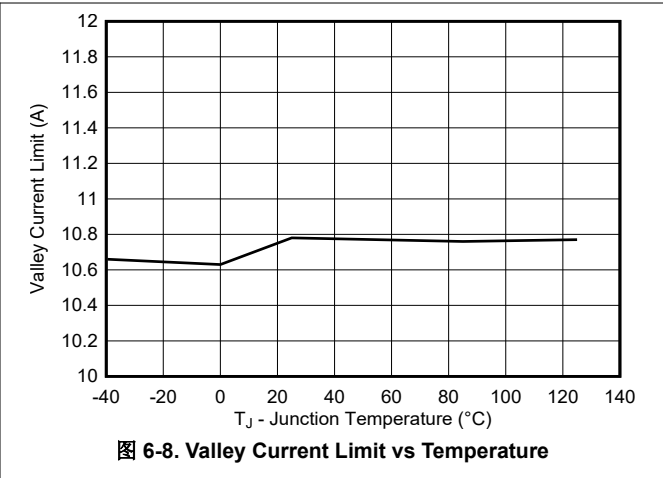
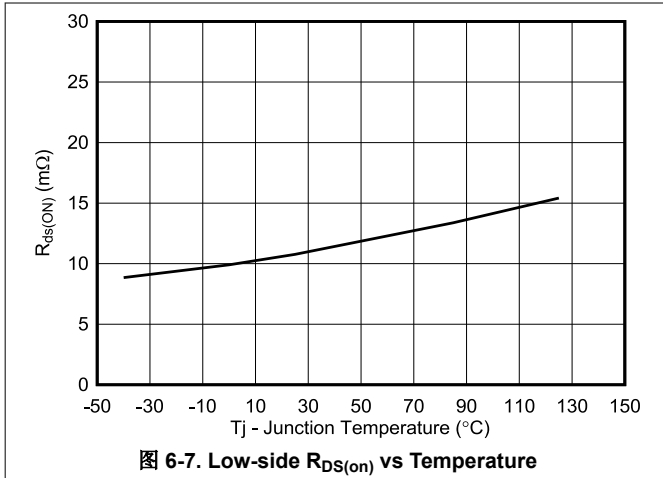

7 Detailed Description

7.1 Overview

The TPS51386 is an 8-A, integrated FET, synchronous buck converter which operates from 4.5-V to 24-V input voltage (VIN), and the output is from 0.6 V to 5.5 V. The proprietary D-CAP3 control mode enables low external component count, ease of design, optimization of the power design for cost, size and efficiency.

The key feature of the TPS51386 is the ULQ™ (Ultra Low Quiescent) extended battery life feature to enable low-bias current DC/DC converter. The ULQ extended battery life feature is extremely beneficial for long battery life in low power operation.

The device employs D-CAP3 control mode control that provides fast transient response with no external compensation components and an accurate feedback voltage. The control topology provides seamless transition between CCM operating mode at higher load condition and DCM operation at lighter load condition. Eco-mode allows the TPS51386 to maintain high efficiency at light load. OOA (Out-of-Audio™) mode makes switching frequency above audible frequency larger than 25 kHz, even there is no loading at output side.

The TPS51386 is able to adapt to both low equivalent series resistance (ESR) output capacitors such as POSCAP or SP-CAP, and ultra-low ESR ceramic capacitors.

7.2 Functional Block Diagram

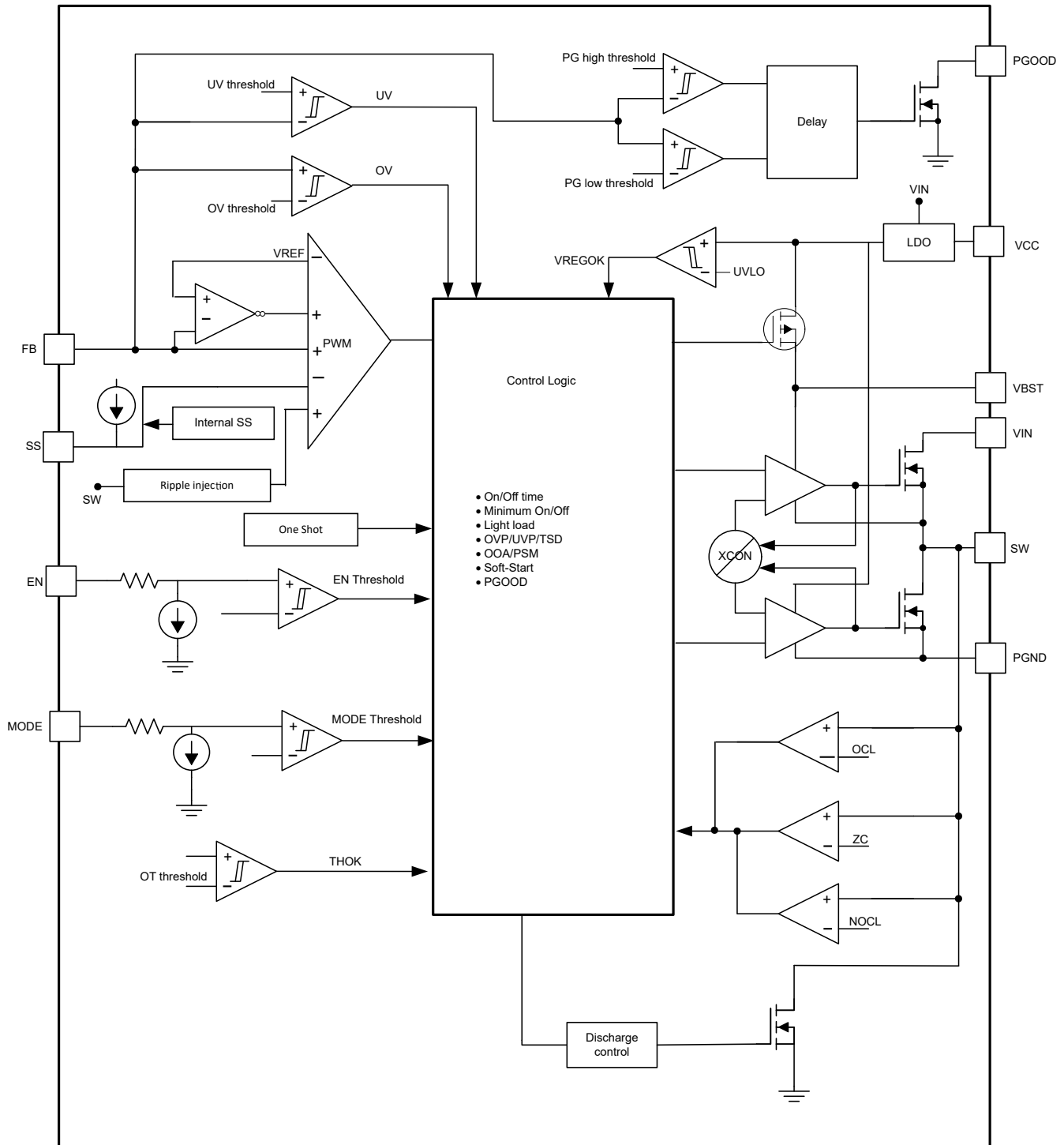

7.3 Feature Description

7.3.1 PWM Operation and D-CAP3™ Control Mode

The TPS51386 operates using the adaptive on-time PWM control with a proprietary D-CAP3 control mode, which enables low external component count with a fast load transient response while maintaining a good output voltage accuracy. At the beginning of each switching cycle, the high side MOSFET is turned on for an on-time set by an internal one shot timer. This on-time is set based on the converter input voltage, output voltage, and

the pseudo-fixed frequency, hence this type of control topology is called an adaptive on-time control. The one shot timer resets and turns on again after the feedback voltage (V_{FB}) falls below the internal reference voltage (V_{REF}). An internal ramp is generated which is fed to the FB pin to simulate the output voltage ripple. This action enables the use of very low-ESR output capacitors such as multi-layered ceramic caps (MLCC). No external current sense network or loop compensation is required for D-CAP3 control mode topology.

The TPS51386 includes an error amplifier that makes the output voltage very accurate. For any control topology that is compensated internally, there is a range of the output filter it can support. The output filter used is a low pass L-C circuit. This L-C filter has double pole that is described in the following equation.

$$f_p = \frac{1}{2 \times \pi \times \sqrt{L_{OUT} \times C_{OUT}}} \quad (1)$$

At low frequencies, the overall loop gain is set by the output set-point resistor divider network and the internal gain. The low frequency L-C double pole has a 180 degree in phase. At the output filter frequency, the gain rolls off at a -40dB per decade rate and the phase drops rapidly. The internal ripple generation network introduces a high-frequency zero that reduces the gain roll off from -40dB to -20dB per decade and increases the phase to 90 degree one decade above the zero frequency. The internal ripple injection high frequency zero is optimized to provide fast transient response performance and also give an consideration to meet the stability requirement with typical external L-C filter. The inductor and capacitor selected for the output filter must be such that the double pole is located close enough to the high-frequency zero so that the phase boost provided by this high-frequency zero provides adequate phase margin for the stability requirement. The crossover frequency of the overall system must usually be targeted to be less than one-fifth of the switching frequency (F_{SW}).

7.3.2 VCC LDO

The VCC pin is the output of the internal 5-V linear regulator that creates the bias for all the internal circuitry and MOSFET gate drivers. The VCC pin must be bypassed with a minimum 1- μ F, 10-V X5R rated capacitor. The UVLO circuit monitors the VCC pin voltage and disables the output when VCC falls below the UVLO threshold.

7.3.3 Soft Start

The TPS51386 has an internal 1-ms soft start, and also an external SS pin is provided for setting higher soft-start time if needed. When the EN pin becomes high, the soft-start function begins ramping up the reference voltage to the PWM comparator.

If the application needs a larger soft-start time, this soft-start time can be set by connecting a capacitor on SS pin. When the EN pin becomes high, the soft-start charge current (I_{SS}) begins charging the external capacitor (C_{SS}) connected between SS and AGND. The device tracks the lower of the internal soft-start voltage or the external soft-start voltage as the reference. The equation for the soft-start time (T_{SS}) is shown in the following equation:

$$T_{SS} = \frac{C_{SS}(\text{nF}) \times V_{REF}(\text{V}) \times 1.4}{I_{SS}(\mu\text{A})} \quad (2)$$

where

- V_{ref} is 0.6 V and I_{SS} is 5 μ A
- 1.4 is typical value of correlation factor

7.3.4 Enable Control

The EN pin controls the turn-on and turn-off of the device. When EN pin voltage is above the turn-on threshold which is around 1.31 V, the device starts switching and when the EN pin voltage falls below the turn-off threshold which is around 1.13V it stops switching.

7.3.5 Power Good

The Power Good (PGOOD) pin is an open drain output. After the FB pin voltage is between 90% and 115% of the internal reference voltage (V_{REF}) the PGOOD is de-asserted and floats after a 500- μ s de-glitch time. TI

recommends a pullup resistor of 100 k Ω to pull it up to VCC. The PGOOD pin is pulled low when the FB pin voltage is lower than V_{UVLP} or greater than V_{OVLP} threshold or in an event of thermal shutdown or during the soft-start period.

7.3.6 Overcurrent Protection and Undervoltage Protection

The output overcurrent limit (OCL) is implemented using a cycle-by-cycle valley detect control circuit. The switch current is monitored during the OFF state by measuring the low-side FET drain to source voltage. This voltage is proportional to the switch current. During the on time of the high-side FET switch, the switch current increases at a linear rate determined by input voltage, output voltage, the on-time and the output inductor value. During the on time of the low-side FET switch, this current decreases linearly. The average value of the switch current is the load current I_{OUT} . If the measured drain to source voltage of the low-side FET is above the voltage proportional to current limit, the low side FET stays on until the current level becomes lower than the OCL level which reduces the output current available. When the current is limited the output voltage tends to drop because the load demand is higher than what the converter can support. When the output voltage falls below 60% of the target voltage, the UVP comparator detects it and shuts down the device after a wait time of 256 μ s. In this type of valley detect control, the load current is higher than the OCL threshold by one half of the peak to peak inductor ripple current. This protection is a latch function, fault latching can be re-set by EN going low or VIN power cycling.

7.3.7 UVLO Protection

Undervoltage Lock Out protection (UVLO) monitors the internal VCC regulator voltage. When the VCC voltage is lower than UVLO threshold voltage, the device is shut off. This protection is non-latching.

7.3.8 Overvoltage Protection

TPS51386 detects overvoltage and undervoltage conditions by monitoring the feedback voltage (VFB). When the feedback voltage becomes higher than 120% of the target voltage, the OVP comparator output goes high and output is discharged after a wait time of 20 μ s. When the OV fault comparator has been tripped for 256 μ s, the part latches off. When the overvoltage condition is removed, output remains latched until EN is toggled to low then high, or the power cycling VIN.

7.3.9 Output Voltage Discharge

TPS51386 has a 160-ohm discharge switch that discharges the output V_{OUT} through the SW pin during any event of fault like output overvoltage, output undervoltage, TSD, or if VCC voltage is below the UVLO and when the EN pin voltage (V_{EN}) is below the turn-on threshold.

7.3.10 Thermal Shutdown

The device monitors the internal die temperature. If this temperature exceeds the thermal shutdown threshold value (T_{SDN} typically 165°C) the device shuts off. This protection is a non-latch protection. The device re-starts switching when the temperature goes below the thermal shutdown threshold and 20°C hysteresis.

7.4 Device Functional Modes

7.4.1 MODE Pin

TPS51386 has a MODE pin that can be used to toggle mode of the device by pulling it high (> 0.8 V) or low (< 0.4 V). When the MODE pin is pulled high, the pin enables the converter to operate in Out-of-Audio (OOA) mode. When the MODE pin is pulled low or float, the converter goes into Power Save Mode (PSM). The MODE pin can be toggled dynamically, even when the converter is in operation.

7.4.2 Out-of-Audio™ Mode

Out-of-Audio (OOA) mode is a unique control feature. If the MODE pin is selected to operate in OOA mode, when the device works at light load, the minimum switching frequency is above 25 kHz which avoids the audible noise in the system.

7.4.3 Power Save Mode (PSM)

The TPS51386 can be placed in power save mode by floating the MODE pin or pulling the MODE pin low (< 0.4 V), which is helpful to improve efficiency at light load.

8 Application and Implementation

备注

以下应用部分中的信息不属于 TI 器件规格的范围，TI 不担保其准确性和完整性。TI 的客户应负责确定器件是否适用于其应用。客户应验证并测试其设计，以确保系统功能。

8.1 Application Information

The schematic shows a typical application for TPS51386. This design converts an input voltage range of 6 V to 24 V down to 5.1 V with a maximum output current of 8 A.

8.2 Typical Application



图 8-1. Application Schematic

8.2.1 Design Requirements

表 8-1. Design Parameters

PARAMETER	CONDITIONS	MIN	TYP	MAX	UNIT
V_{OUT}	Output voltage		5.1		V
I_{OUT}	Output current			8	A
V_{IN}	Input voltage	6	19.5	24	V
$V_{OUT(ripple)}$	Output voltage ripple	$V_{IN} = 19.5\text{ V}, I_{OUT} = 8\text{ A}$		50	mV(P-P)
F_{SW}	Switching frequency	$V_{IN} = 19.5\text{ V}, I_{OUT} = 8\text{ A}$		600	kHz
Operating Mode		Float MODE pin (default)		PSM	
T_A	Ambient temperature		25		°C

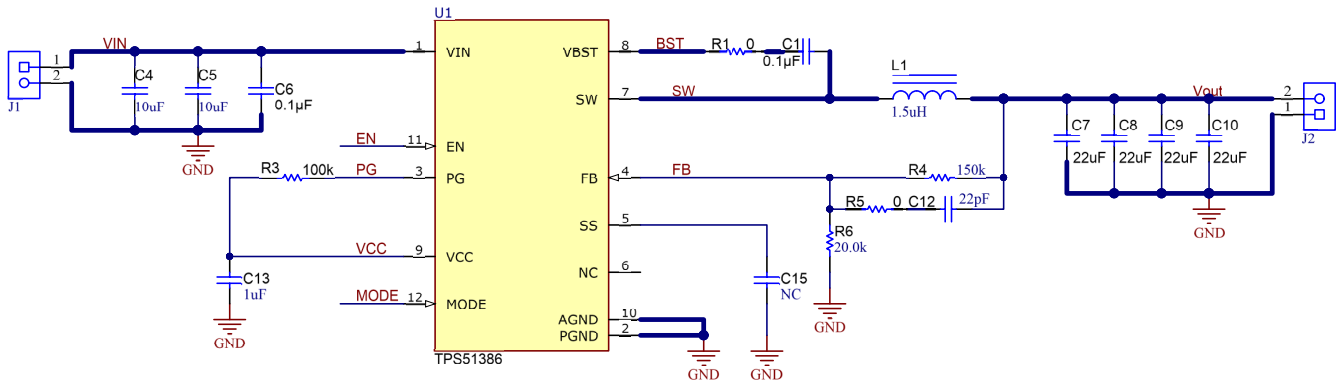
8.2.2 Detailed Design Procedure

8.2.2.1 External Component Selection

8.2.2.1.1 Inductor Selection

The inductor ripple current is filtered by the output capacitor. A higher inductor ripple current means the output capacitor must have a ripple current rating higher than the inductor ripple current. See 表 8-2 for recommended inductor values.

The RMS and peak currents through the inductor can be calculated using 方程式 3 and 方程式 4. Make sure that the inductor is rated to handle these currents.

$$I_{L(rms)} = \sqrt{\left(I_{OUT}^2 + \frac{1}{12} \times \left(\frac{V_{OUT} \times (V_{IN(max)} - V_{OUT})}{V_{IN(max)} \times L_{OUT} \times F_{SW}} \right)^2 \right)} \quad (3)$$

$$I_{L(\text{peak})} = I_{\text{OUT}} + \frac{I_{\text{OUT(ripple)}}}{2} \quad (4)$$

During transient, short-circuit conditions the inductor current can increase up to the current limit of the device, so choose an inductor with a saturation current higher than the peak current under current limit condition.

8.2.2.1.2 Output Capacitor Selection

After selecting the inductor the output capacitor must be optimized. In D-CAP3 control mode, the regulator reacts within one cycle to the change in the duty cycle so the good transient performance can be achieved without needing large amounts of output capacitance. 表 8-2 lists the recommended output capacitance range.

Ceramic capacitors have very low ESR, otherwise the maximum ESR of the capacitor must be less than $V_{\text{OUT(ripple)}}/I_{\text{OUT(ripple)}}$

表 8-2. Recommended Component Values

V _{OUT} (V)	R _{LOWER} (Kohm)	R _{UPPER} (Kohm)	F _{sw} (kHz)	Typical L _{OUT} (μH)	C _{OUT(Range)} (μF)	C _{FF(Range)} (pF)
1	30	20	600	0.68/0.82	44-500	-
1.8	20	40	600	1.0/1.2	44-500	0-100
3.3	20	90	600	1.5/2.2	44-500	0-100
5	20	147	600	1.5/2.2	44-500	0-100

8.2.2.1.3 Input Capacitor Selection

The minimum input capacitance required is given in 方程式 5.

$$C_{\text{IN(min)}} = \frac{I_{\text{OUT}} \times V_{\text{OUT}}}{V_{\text{INripple}} \times V_{\text{IN}} \times F_{\text{SW}}} \quad (5)$$

TI recommends using a high quality X5R or X7R input decoupling capacitors of 22 μF on the input voltage pin. The voltage rating on the input capacitor must be greater than the maximum input voltage. The capacitor must also have a ripple current rating greater than the maximum input current ripple of the application. The input ripple current is calculated by 方程式 6 below:

$$I_{\text{CIN(rms)}} = I_{\text{OUT}} \times \sqrt{\frac{V_{\text{OUT}}}{V_{\text{IN(min)}}} \times \frac{(V_{\text{IN(min)}} - V_{\text{OUT}})}{V_{\text{IN(min)}}}} \quad (6)$$

8.2.3 Application Curves

$V_{IN} = 19.5\text{ V}$, $T_a = 25^\circ\text{C}$ unless otherwise specified.



图 8-2. Efficiency, PSM Mode



图 8-3. Efficiency, OOA Mode

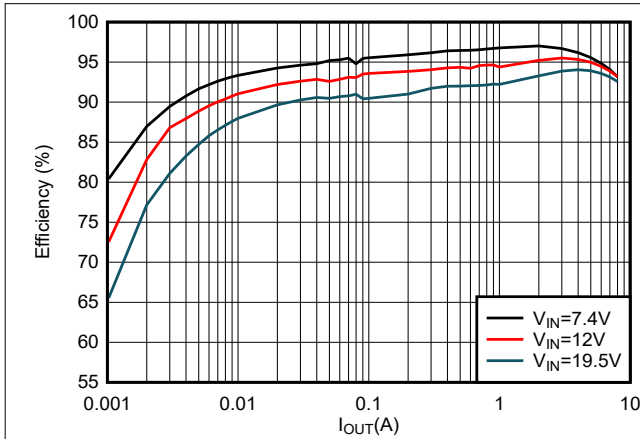

图 8-4. Switching Frequency, PSM Mode

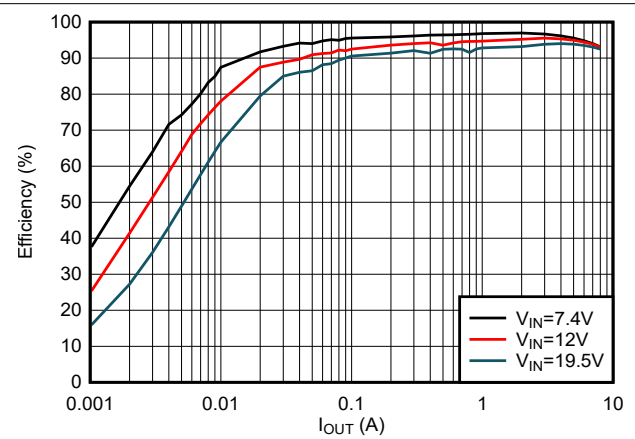

图 8-5. Switching Frequency, OOA Mode

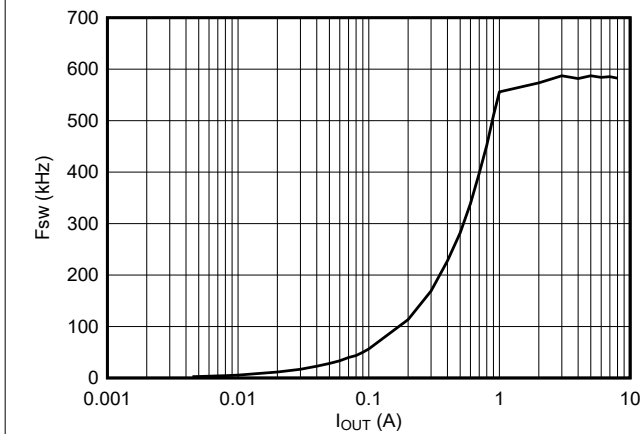

图 8-6. Start-Up Relative to EN Rising, $I_{out} = 0.01\text{ A}$, PSM Mode

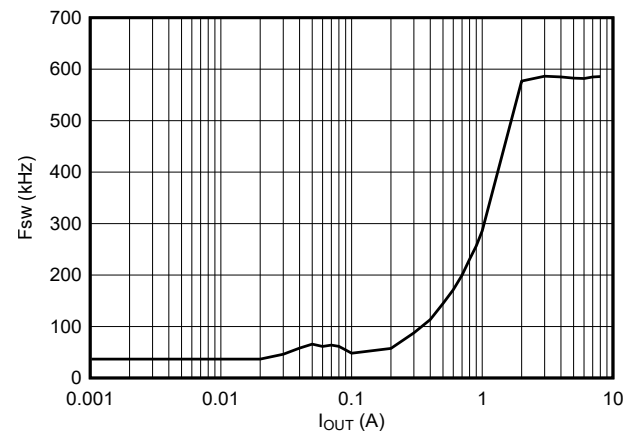

图 8-7. Shutdown Relative to EN Falling, $I_{out} = 0.01\text{ A}$, PSM Mode

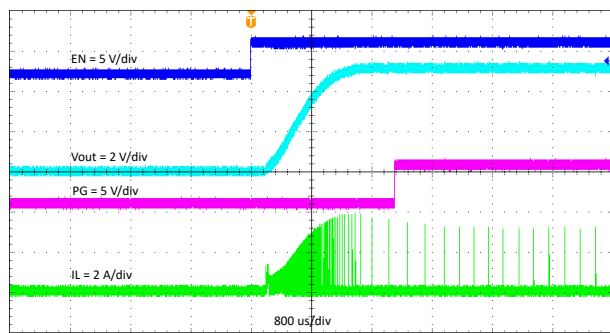

图 8-8. Start-Up Relative to EN Rising, Iout = 0.01 A, OOA Mode

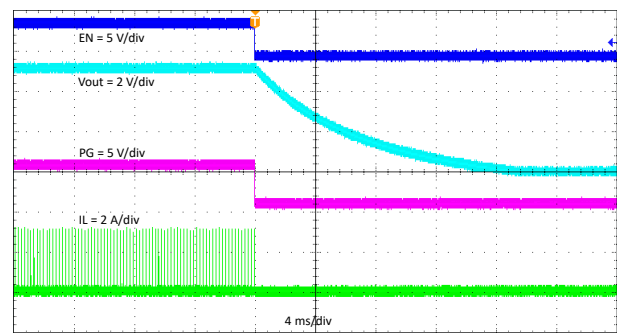

图 8-9. Shutdown Relative to EN Falling, Iout = 0.01 A, OOA Mode

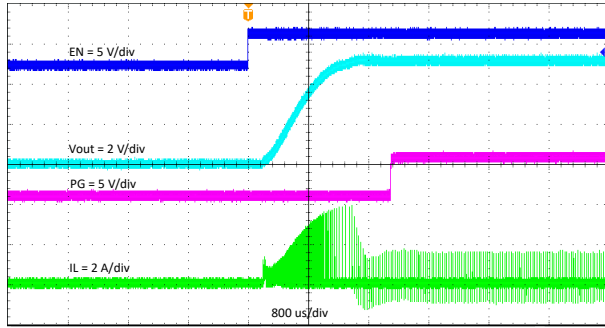

图 8-10. Start-Up Relative to Vin Rising, Iout = 8 A

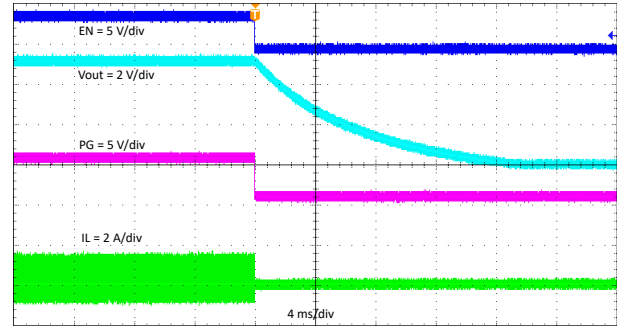

图 8-11. Shutdown Relative to Vin Falling, Iout = 8 A

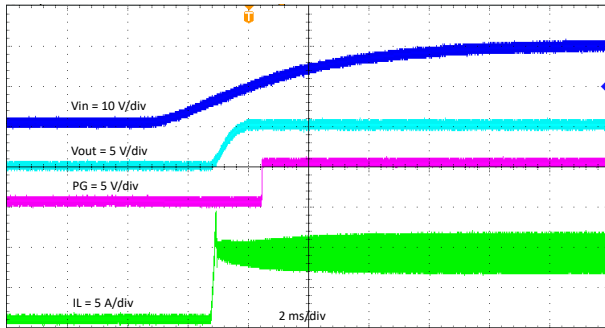

图 8-12. Output Voltage Ripple, Iout = 0 A, PSM Mode

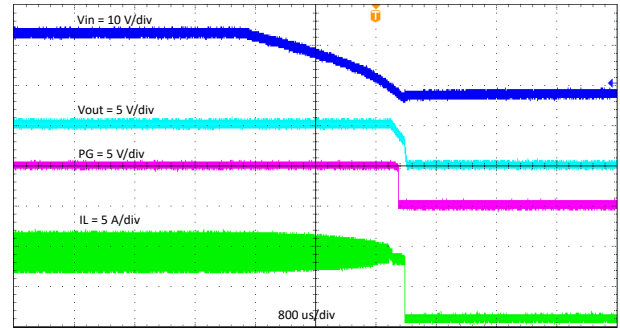

图 8-13. Output Voltage Ripple, Iout = 0 A, OOA Mode

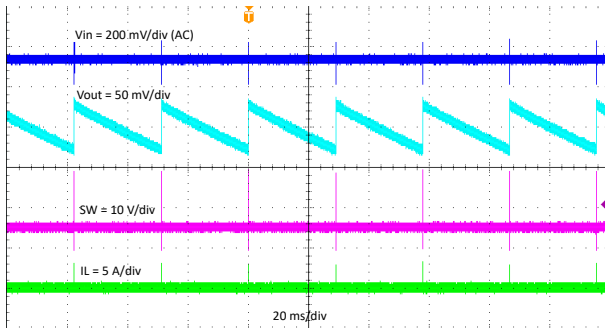

图 8-14. Output Voltage Ripple, Iout = 8 A

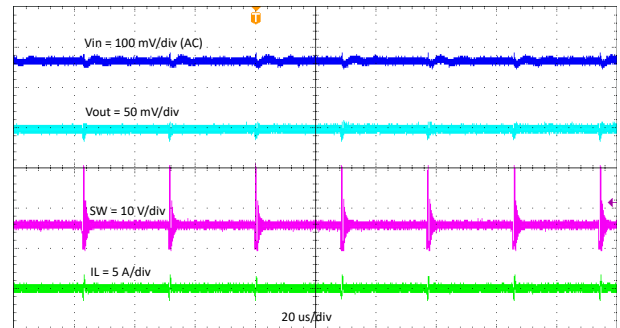

图 8-15. Transient Response, 1.6 A to 6.4 A with 2.5 A/us SR

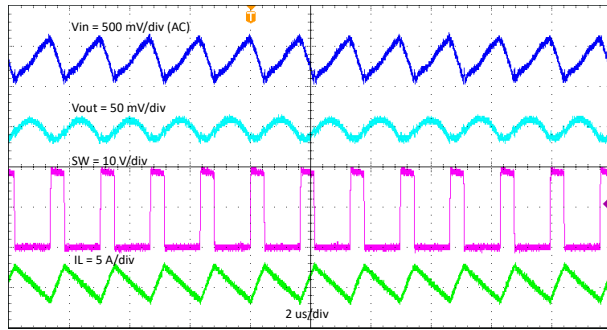

图 8-16. Transient Response, 0.8 A to 7.2 A with 2.5 A/us SR

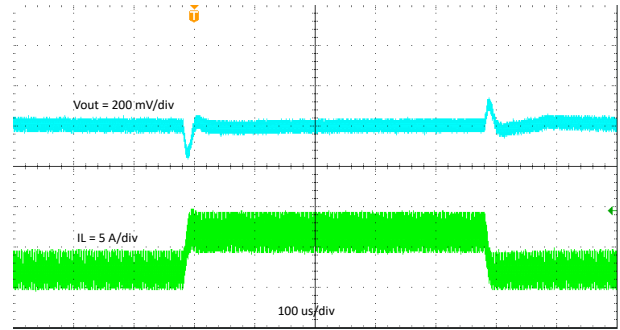

图 8-17. Normal Operation to Output Hard Short

8.3 Power Supply Recommendations

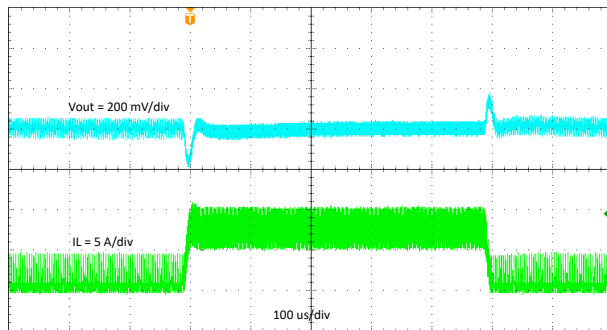
The TPS51386 are intended to be powered by a well regulated DC voltage. The input voltage range is 4.5 V to 24 V. TPS51386 are buck converters. The input supply voltage must be greater than the desired output voltage for proper operation. Input supply current must be appropriate for the desired output current. If the input voltage supply is located far from the TPS51386 circuit, TI recommends some additional input bulk capacitance. Typical values are 100 μ F to 470 μ F.

8.4 Layout

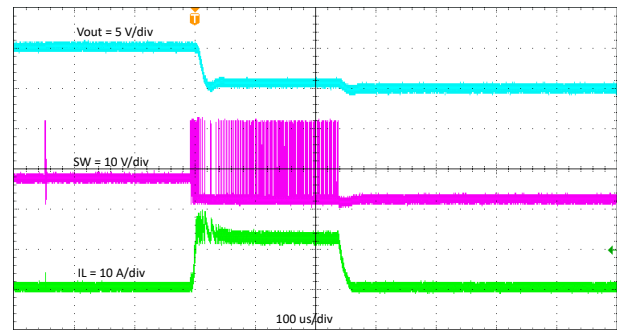
8.4.1 Layout Guidelines

Layout is a critical portion of good power supply design. Key guidelines to follow for the layout are:

- Make VIN, PGND, and SW traces as wide as possible to reduce trace impedance and improve heat dissipation. Use vias and traces on others layers to reduce VIN and PGND trace impedance.
- Use multiple vias near the PGND pins and use the layer directly below the device to connect them together, which helps to minimize noise and can help heat dissipation
- Use vias near both VIN pins and provide a low impedance connection between them through an internal layer.
- Place the smaller value high frequency bypass ceramic capacitors from each VIN to PGND pins and place them as close as possible to the device on the same side of the PCB. Place the remaining ceramic input capacitance next to these high frequency bypass capacitors. The remaining input capacitance can be placed on the other side of the board but use as many vias as possible to minimize impedance between the capacitors and the pins of the IC.
- Route FB traces away from the noisy switch node. Place the bottom resistor in the FB divider as close as possible to the FB pin of the IC. Also keep the upper feedback resistor and the feedforward capacitor near the IC. Connect the FB divider to the output voltage at the desired point of regulation.
- Place the BOOT-SW capacitor as close as possible to the BOOT and SW pins.

8.4.2 Layout Example

The following figure shows the recommended top side layout.



图 8-18. Top Side Layout

9 Device and Documentation Support

9.1 Device Support

9.1.1 Third-Party Products Disclaimer

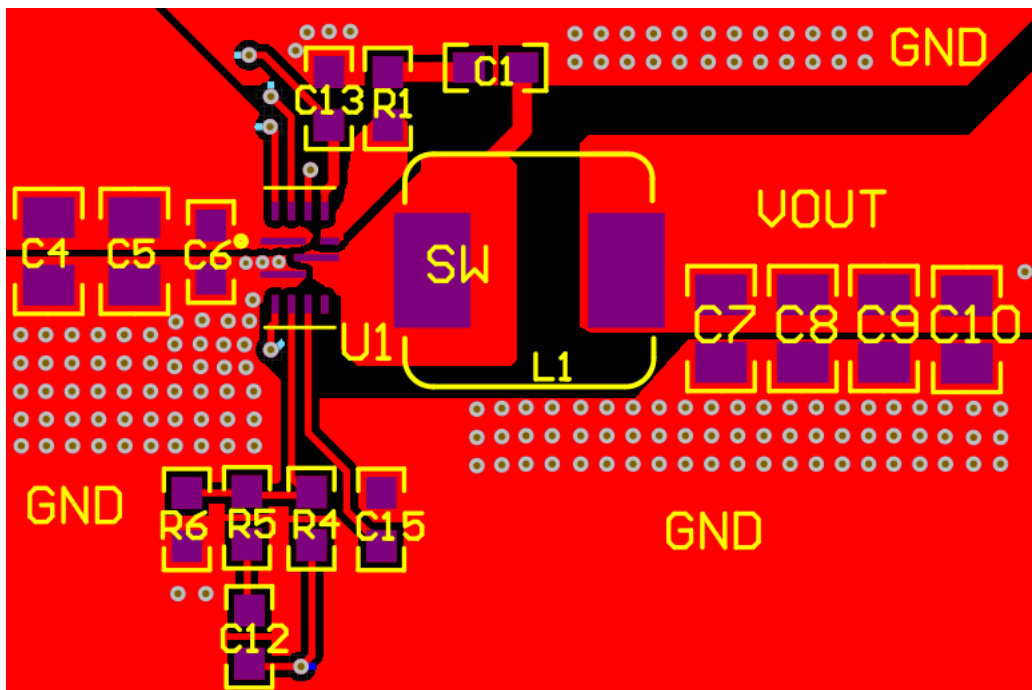
TI'S PUBLICATION OF INFORMATION REGARDING THIRD-PARTY PRODUCTS OR SERVICES DOES NOT CONSTITUTE AN ENDORSEMENT REGARDING THE SUITABILITY OF SUCH PRODUCTS OR SERVICES OR A WARRANTY, REPRESENTATION OR ENDORSEMENT OF SUCH PRODUCTS OR SERVICES, EITHER ALONE OR IN COMBINATION WITH ANY TI PRODUCT OR SERVICE.

9.2 接收文档更新通知

要接收文档更新通知，请导航至 [ti.com](https://www.ti.com) 上的器件产品文件夹。点击 [订阅更新](#) 进行注册，即可每周接收产品信息更改摘要。有关更改的详细信息，请查看任何已修订文档中包含的修订历史记录。

9.3 支持资源

[TI E2E™ 支持论坛](#) 是工程师的重要参考资料，可直接从专家获得快速、经过验证的解答和设计帮助。搜索现有解答或提出自己的问题可获得所需的快速设计帮助。

链接的内容由各个贡献者“按原样”提供。这些内容并不构成 TI 技术规范，并且不一定反映 TI 的观点；请参阅 TI 的《[使用条款](#)》。

9.4 Trademarks

D-CAP3™, HotRod™, ULQ™, Out-of-Audio™, and TI E2E™ are trademarks of Texas Instruments.

所有商标均为其各自所有者的财产。

9.5 静电放电警告



静电放电 (ESD) 会损坏这个集成电路。德州仪器 (TI) 建议通过适当的预防措施处理所有集成电路。如果不遵守正确的处理和安装程序，可能会损坏集成电路。

ESD 的损坏小至导致微小的性能降级，大至整个器件故障。精密的集成电路可能更容易受到损坏，这是因为非常细微的参数更改都可能会导致器件与其发布的规格不相符。

9.6 术语表

TI 术语表

本术语表列出并解释了术语、首字母缩略词和定义。

10 Mechanical, Packaging, and Orderable Information

The following pages include mechanical, packaging, and orderable information. This information is the most current data available for the designated devices. This data is subject to change without notice and revision of this document. For browser-based versions of this data sheet, refer to the left-hand navigation.

PACKAGING INFORMATION

Orderable part number	Status (1)	Material type (2)	Package Pins	Package qty Carrier	RoHS (3)	Lead finish/ Ball material (4)	MSL rating/ Peak reflow (5)	Op temp (°C)	Part marking (6)
TPS51386RJNR	Active	Production	VQFN-HR (RJN) 12	3000 LARGE T&R	Yes	SN	Level-2-260C-1 YEAR	-40 to 125	51386
TPS51386RJNR.A	Active	Production	VQFN-HR (RJN) 12	3000 LARGE T&R	Yes	SN	Level-2-260C-1 YEAR	-40 to 125	51386

(1) **Status:** For more details on status, see our [product life cycle](#).

(2) **Material type:** When designated, preproduction parts are prototypes/experimental devices, and are not yet approved or released for full production. Testing and final process, including without limitation quality assurance, reliability performance testing, and/or process qualification, may not yet be complete, and this item is subject to further changes or possible discontinuation. If available for ordering, purchases will be subject to an additional waiver at checkout, and are intended for early internal evaluation purposes only. These items are sold without warranties of any kind.

(3) **RoHS values:** Yes, No, RoHS Exempt. See the [TI RoHS Statement](#) for additional information and value definition.

(4) **Lead finish/Ball material:** Parts may have multiple material finish options. Finish options are separated by a vertical ruled line. Lead finish/Ball material values may wrap to two lines if the finish value exceeds the maximum column width.

(5) **MSL rating/Peak reflow:** The moisture sensitivity level ratings and peak solder (reflow) temperatures. In the event that a part has multiple moisture sensitivity ratings, only the lowest level per JEDEC standards is shown. Refer to the shipping label for the actual reflow temperature that will be used to mount the part to the printed circuit board.

(6) **Part marking:** There may be an additional marking, which relates to the logo, the lot trace code information, or the environmental category of the part.

Multiple part markings will be inside parentheses. Only one part marking contained in parentheses and separated by a "~" will appear on a part. If a line is indented then it is a continuation of the previous line and the two combined represent the entire part marking for that device.

Important Information and Disclaimer:The information provided on this page represents TI's knowledge and belief as of the date that it is provided. TI bases its knowledge and belief on information provided by third parties, and makes no representation or warranty as to the accuracy of such information. Efforts are underway to better integrate information from third parties. TI has taken and continues to take reasonable steps to provide representative and accurate information but may not have conducted destructive testing or chemical analysis on incoming materials and chemicals. TI and TI suppliers consider certain information to be proprietary, and thus CAS numbers and other limited information may not be available for release.

In no event shall TI's liability arising out of such information exceed the total purchase price of the TI part(s) at issue in this document sold by TI to Customer on an annual basis.

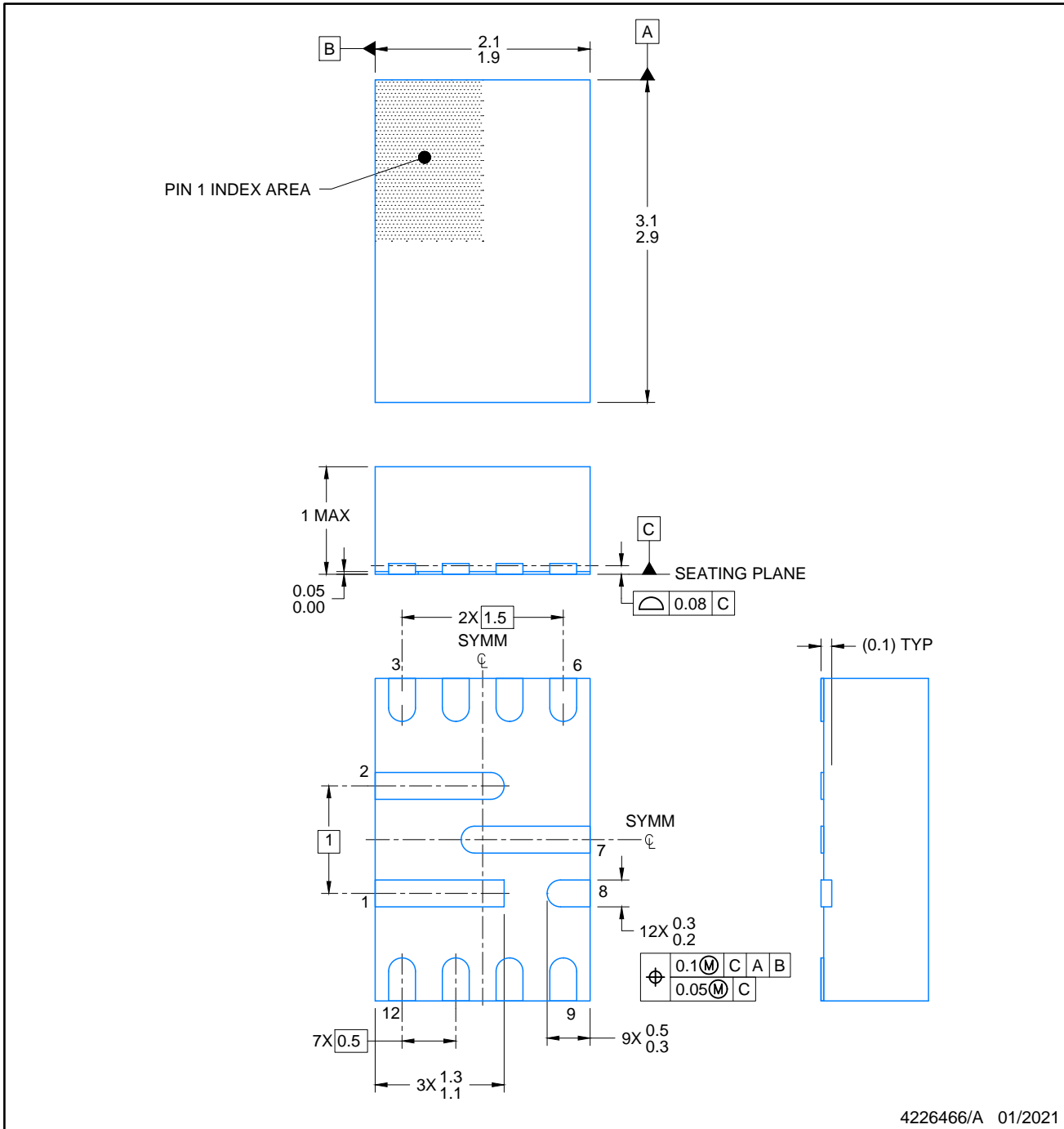

4226466/A 01/2021

NOTES:

1. All linear dimensions are in millimeters. Any dimensions in parenthesis are for reference only. Dimensioning and tolerancing per ASME Y14.5M.
2. This drawing is subject to change without notice.

EXAMPLE BOARD LAYOUT

VQFN-HR - 1 mm max height

RJN0012A

PLASTIC SMALL OUTLINE- NO LEAD

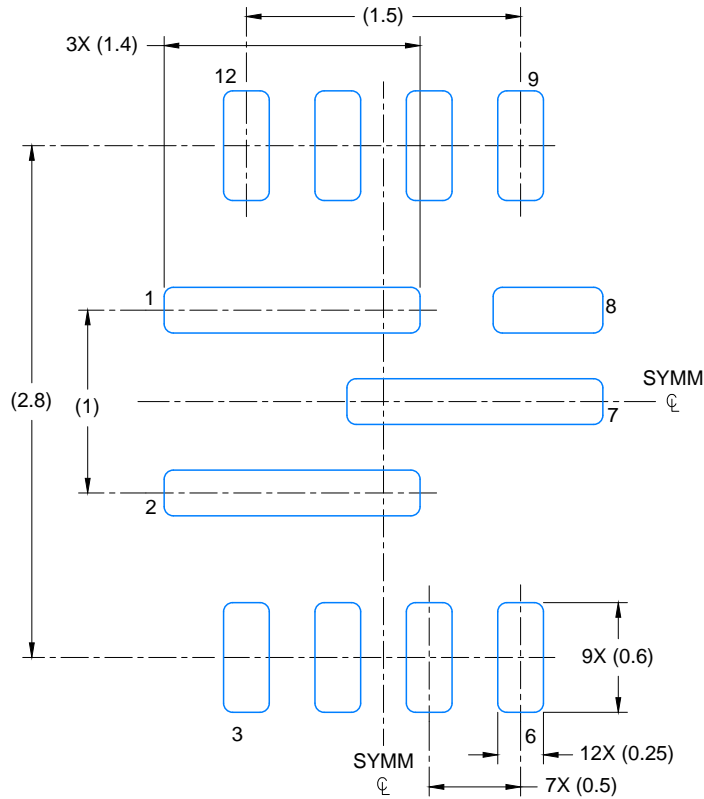

LAND PATTERN EXAMPLE
EXPOSED METAL SHOWN
SCALE: 25X

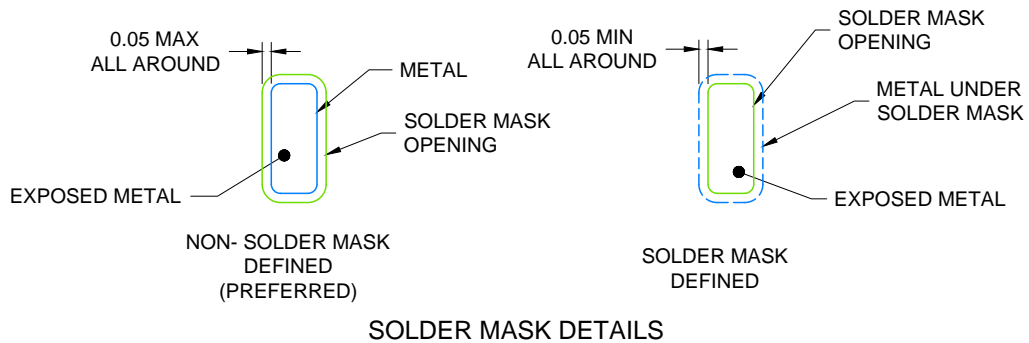

4226466/A 01/2021

NOTES: (continued)

3. For more information, see Texas Instruments literature number SLUA271 (www.ti.com/lit/slua271) .
4. Solder mask tolerances between and around signal pads can vary based on board fabrication site.

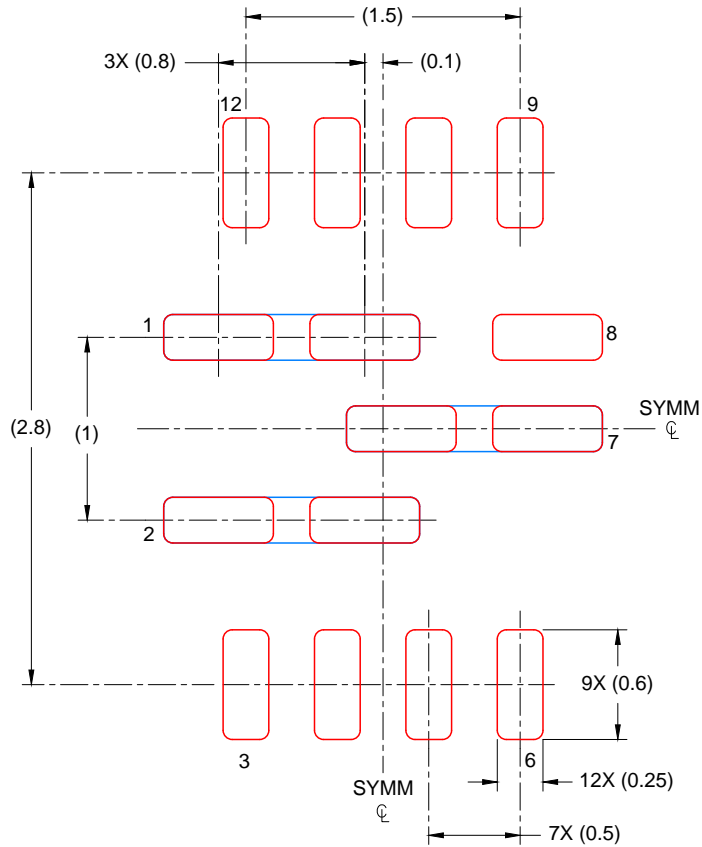

SOLDER PASTE EXAMPLE
 BASED ON 0.1mm THICK STENCIL

EXPOSED PAD
 PINS 1,2,7: 86%
 SCALE: 25X

4226466/A 01/2021

NOTES: (continued)

5. Laser cutting apertures with trapezoidal walls and rounded corners may offer better paste release. IPC-7525 may have alternate design recommendations.

重要通知和免责声明

TI“按原样”提供技术和可靠性数据（包括数据表）、设计资源（包括参考设计）、应用或其他设计建议、网络工具、安全信息和其他资源，不保证没有瑕疵且不做任何明示或暗示的担保，包括但不限于对适销性、与某特定用途的适用性或不侵犯任何第三方知识产权的暗示担保。

这些资源可供使用 TI 产品进行设计的熟练开发人员使用。您将自行承担以下全部责任：(1) 针对您的应用选择合适的 TI 产品，(2) 设计、验证并测试您的应用，(3) 确保您的应用满足相应标准以及任何其他安全、安保法规或其他要求。

这些资源如有变更，恕不另行通知。TI 授权您仅可将这些资源用于研发本资源所述的 TI 产品的相关应用。严禁以其他方式对这些资源进行复制或展示。您无权使用任何其他 TI 知识产权或任何第三方知识产权。对于因您对这些资源的使用而对 TI 及其代表造成的任何索赔、损害、成本、损失和债务，您将全额赔偿，TI 对此概不负责。

TI 提供的产品受 [TI 销售条款](#)、[TI 通用质量指南](#) 或 [ti.com](#) 上其他适用条款或 TI 产品随附的其他适用条款的约束。TI 提供这些资源并不会扩展或以其他方式更改 TI 针对 TI 产品发布的适用的担保或担保免责声明。除非德州仪器 (TI) 明确将某产品指定为定制产品或客户特定产品，否则其产品均为按确定价格收入目录的标准通用器件。

TI 反对并拒绝您可能提出的任何其他或不同的条款。

版权所有 © 2025，德州仪器 (TI) 公司

最后更新日期：2025 年 10 月