

## INTEGRATED LDO WITH SWITCHOVER CIRCUIT FOR NOTEBOOK COMPUTERS

### FEATURES

- **Wide Input Voltage Range: 4.5 V to 28 V**
- **5-V/3.3-V, 100-mA, LDO Output**
- **Glitch Free Switch Over Circuit**
- **Always-On 3.3-V, 5-mA LDO Output for RTC**
- **250 kHz Clock Output for Charge Pump**
- **Thermal Shutdown (Non-latch)**
- **10Ld QFN (DRC) Package**

### APPLICATIONS

- **Notebook Computers**
- **Mobile Digital Consumer Products**

### DESCRIPTION

The TPS51103 integrates three LDOs. The 5-V and 3.3-V LDOs are both rated at 100 mA and also include a glitch-free switch-over feature allowing for optimized battery life. An additional 3.3-V LDO is designed to provide an *always on* power output for the real time clock (RTC). The TPS51103 integrates a clock output to use with an external charge pump. The TPS51103 offers an innovative solution for optimizing the complex and multiple power rails typically found in a Notebook Computer. The TPS51103 is available in the 10-pin QFN package and is specified from  $-40^{\circ}\text{C}$  to  $85^{\circ}\text{C}$ .

### TYPICAL APPLICATION CIRCUIT

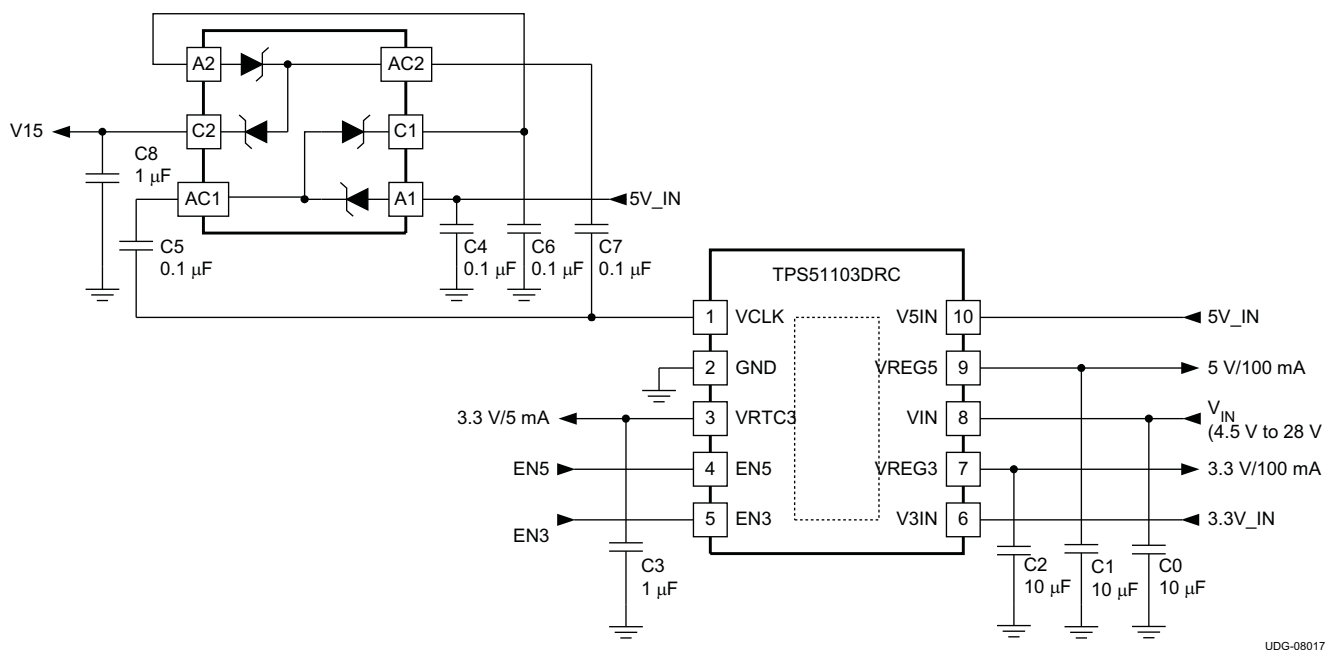

UDG-08017



Please be aware that an important notice concerning availability, standard warranty, and use in critical applications of Texas Instruments semiconductor products and disclaimers thereto appears at the end of this data sheet.



These devices have limited built-in ESD protection. The leads should be shorted together or the device placed in conductive foam during storage or handling to prevent electrostatic damage to the MOS gates.

### ORDERING INFORMATION

$T_A$	PACKAGE	PART NUMBER	TAPE & REEL QUANTITY	ECO-PLAN
–40°C to 85°C	Plastic DRC <sup>(1)</sup>	TPS51103DRCT	250	Green (RoHS and No Sb/Br)
		TPS51103DRCR	3000	

(1) For the most current package and ordering information, see the *Package Option Addendum* at the end of this document, or see the TI website at [www.ti.com](http://www.ti.com).

### ABSOLUTE MAXIMUM RATINGS

over operating free-air temperature range (unless otherwise noted) <sup>(1)</sup>

	VALUE	UNIT
Input voltage range <sup>(2)</sup>	V <sub>IN</sub>	–0.3 to 30
	EN3, EN5, V3IN	–0.3 to 6
	V5IN	–0.3 to 6
	V5IN, (V <sub>VIN</sub> < 5.7 V)	–0.3 to V <sub>VIN</sub> + 0.3
Output voltage range <sup>(2)</sup>	V <sub>RTC3</sub> , V <sub>CLK</sub> , V <sub>REG3</sub> , V <sub>REG5</sub>	–0.3 to 6
Junction temperature, T <sub>J</sub>	150	°C
Storage temperature, T <sub>st</sub>	–55 to 150	°C

- (1) Stresses beyond those listed under *absolute maximum ratings* may cause permanent damage to the device. These are stress ratings only and functional operation of the device at these or any other conditions beyond those indicated under *recommended operating conditions* is not implied. Exposure to absolute-maximum-rated conditions for extended periods may affect device reliability.
- (2) All voltage values are with respect to the network ground terminal unless otherwise noted.

### DISSIPATION RATINGS<sup>(1)</sup>

PACKAGE	POWER RATING BELOW AND AT $T_A = 25^\circ\text{C}$	DERATING FACTOR ABOVE $T_A = 25^\circ\text{C}$	$T_A = 85^\circ\text{C}$ POWER RATING
10-pin DRC	1.256 W	12.6 mW/°C	0.502 W

(1)  $\theta_{JA}$  (junction to air) for high-K board in still air environment is 80°C/W.

### RECOMMENDED OPERATING CONDITIONS

	MIN	TYP	MAX	UNIT
Input voltage range	V <sub>IN</sub>	4.5	28	V
	EN5, EN3, V3IN	–0.1	5.5	
	V5IN	–0.1	5.5	
	V5IN, (V <sub>VIN</sub> < 5.5 V)	–0.1	V <sub>VIN</sub>	
Output voltage range	V <sub>CLK</sub> , V <sub>RTC3</sub> , V <sub>REG3</sub> , V <sub>REG5</sub>	–0.1	5.5	
Operating free-air temperature, T <sub>A</sub>	–40		85	°C

## ELECTRICAL CHARACTERISTICS

 over recommended free-air temperature range,  $V_{VIN}=12\text{ V}$ , (unless otherwise noted)

PARAMETER		TEST CONDITIONS	MIN	TYP	MAX	UNIT
<b>SUPPLY CURRENT</b>						
$I_{VIN}$	$V_{IN}$ supply current	$I_{VIN}$ current, $T_A = 25^\circ\text{C}$ , No Load, $V_{EN3}=V_{EN5}=5\text{ V}$ , $V_{V5IN} = V_{V3IN} = 0\text{ V}$		35	50	$\mu\text{A}$
$I_{VINSTBY}$	$V_{IN}$ standby current	$I_{VIN}$ current, $T_A = 25^\circ\text{C}$ , No Load, $V_{EN3}=V_{EN5}= 0\text{ V}$ , $V_{V5IN} = V_{V3IN} = 0\text{ V}$		7	20	$\mu\text{A}$
<b>VRTC3 OUTPUT</b>						
$V_{VRTC3}$	$VRTC3$ output voltage	$I_{VRTC3} = 1\text{ mA}$ , $T_A = 25^\circ\text{C}$	3.27	3.32	3.37	V
		$0\text{ A} < I_{VRTC3} < 5\text{ mA}$ , $5.5\text{ V} < V_{VIN} < 28\text{ V}$	3.17		3.43	
		$0\text{ A} < I_{VRTC3} < 5\text{ mA}$ , $4.5\text{ V} < V_{VIN} \leq 5.5\text{ V}$	3.15		3.43	
$I_{VRTC3}$	$VRTC3$ output current	$V_{VRTC3} = 2\text{ V}$	5	10	15	mA
<b>VREG5 OUTPUT</b>						
$V_{VREG5}$	$VREG5$ output voltage	$V_{V5IN} = 0\text{ V}$ , $I_{VREG5} = 1\text{ mA}$ , $T_A = 25^\circ\text{C}$	4.95	5.05	5.15	V
		$V_{V5IN} = 0\text{ V}$ , $10\text{ }\mu\text{A} < I_{VREG5} < 100\text{ mA}$ , $6.5\text{ V} < V_{VIN} < 28\text{ V}$	4.80		5.20	
		$V_{V5IN} = 0\text{ V}$ , $0\text{ A} \leq I_{VREG5} < 50\text{ mA}$ , $5.5\text{ V} < V_{VIN} < 28\text{ V}$	4.75		5.25	
$V_{VREG5DO}$	$VREG5$ drop out voltage	$V_{V5IN} = 0\text{ V}$ , $I_{VREG5} = 50\text{ mA}$ , $V_{VREG5} = 4.5\text{ V}$		400	750	mV
$I_{VREG5}$	$VREG5$ output current	$V_{V5IN} = 0\text{ V}$ , $V_{VREG5} = 4.5\text{ V}$	100	160	250	mA
$V_{TH5VSW}$	Switch overthreshold	Turns on	4.45	4.65	4.80	V
		Hysteresis	25	50	75	mV
$R_{5VSW}$	5V SW $R_{DS(on)}$	$V_{V5IN} = 5\text{ V}$ , $I_{VREG5} = 100\text{ mA}$		1		$\Omega$
$Td_5$	Delay for 5V SW	Turns on		1		ms
<b>VREG3 OUTPUT</b>						
$V_{VREG3}$	$VREG3$ output voltage	$V_{V3IN} = 0\text{ V}$ , $I_{VREG3} = 1\text{ mA}$ , $T_A = 25^\circ\text{C}$	3.23	3.33	3.37	V
		$V_{V3IN} = 0\text{ V}$ , $10\text{ }\mu\text{A} < I_{VREG3} < 100\text{ mA}$ , $6.5\text{ V} < V_{VIN} < 28\text{ V}$	3.17		3.43	
		$V_{V3IN} = 0\text{ V}$ , $0\text{ A} < I_{VREG3} < 50\text{ mA}$ , $5.5\text{ V} < V_{VIN} < 28\text{ V}$	3.14		3.47	
		$V_{V3IN} = 0\text{ V}$ , $0\text{ A} < I_{VREG3} < 50\text{ mA}$ , $4.5\text{ V} < V_{VIN} \leq 5.5\text{ V}$	3.00		3.47	
$I_{VREG3}$	$VREG3$ output current	$V_{V3IN} = 0\text{ V}$ , $V_{VREG3} = 3\text{ V}$	100	150	250	mA
$V_{TH3VSW}$	Switchover threshold	Turns on	2.95	3.07	3.17	V
		Hysteresis	20	35	50	mV
$R_{3VSW}$	3V SW $R_{DS(on)}$	$V_{V3IN} = 3.3\text{ V}$ , $I_{VREG5} = 100\text{ mA}$		1.5		$\Omega$
$Td_3$	Delay for 3V SW	Turns on		1		ms
<b>LOGIC THRESHOLD</b>						
$V_{THEN}$	EN3, EN5 threshold	Enable		1.05	2.0	V
		Shutdown	0.3	0.7		
$I_{EN3,5}$	EN3, EN5 pulldown current	$V_{EN3} = 3\text{ V}$ , $V_{EN5} = 3\text{ V}$	0.5	1.5	3.0	$\mu\text{A}$
<b>VCLK OUTPUT</b>						
$f_{VCLK}$	Clock frequency	$T_A = 25^\circ\text{C}$	200	250	320	kHz
$R_{VCLK}$	Driver impedance	V5IN to VCLK, $I_{VCLK} = 10\text{ mA}$		6	15	$\Omega$
		VCLK to GND, $I_{VCLK} = 10\text{ mA}$		4	15	
$V_{THV5IN}$	V5IN threshold	VCLK on	1.5	2.0	2.5	V
		Hysteresis		0.3		
<b>THERMAL SHUTDOWN</b>						
TSDN	Thermal SDN threshold	Shutdown temperature <sup>(1)</sup>		150		$^\circ\text{C}$
		Hysteresis <sup>(1)</sup>		20		

(1) Ensured by design. Not production tested.

**DRC PACKAGE  
(Top View)**

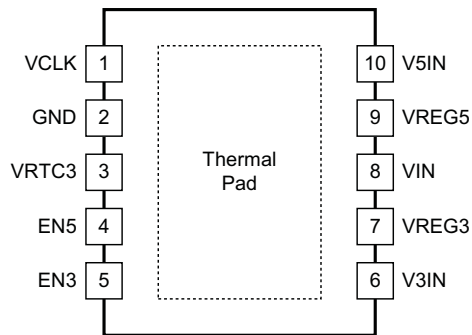

**TERMINAL FUNCTIONS**

TERMINAL		I/O	DESCRIPTION
NAME	NO.		
EN3	5	I	3.3-V LDO enable input.
EN5	4	I	5-V LDO enable input.
GND	2	–	Ground.
V3IN	6	I	3.3-V switchover power supply input. Switchover occurs 1 ms after this input voltage reaches the threshold voltage.
V5IN	10	I	5-V switchover power supply input. Switchover occurs 1 ms after this input voltage reaches to threshold voltage.
VCLK	1	O	50% duty 250-kHz clock output for charge pump power supply.
VIN	8	I	Power supply input for LDOs.
VREG3	7	O	3.3-V 100 mA LDO output.
VREG5	9	O	5-V 100 mA LDO output.
VRTC3	3	O	3.3-V 5 mA always on LDO output for RTC.

FUNCTIONAL BLOCK DIAGRAM

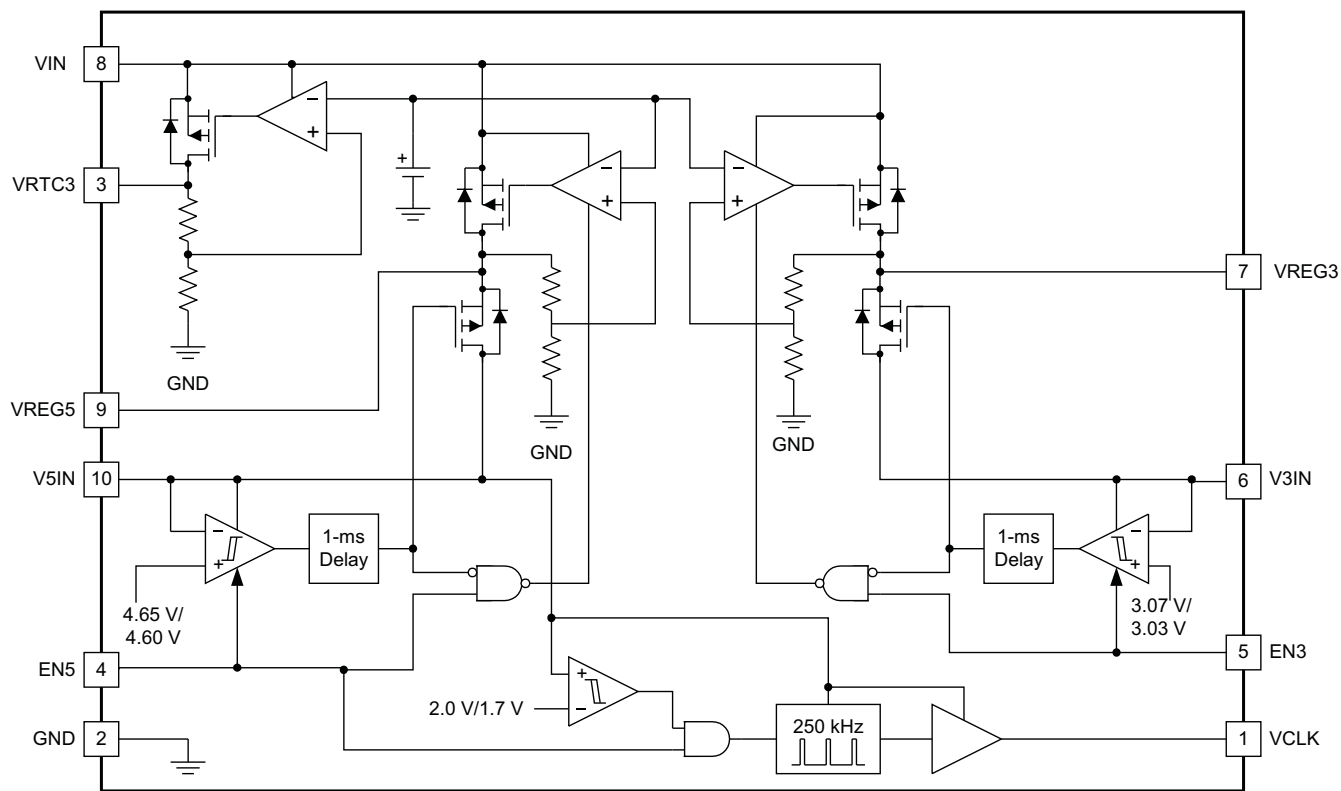

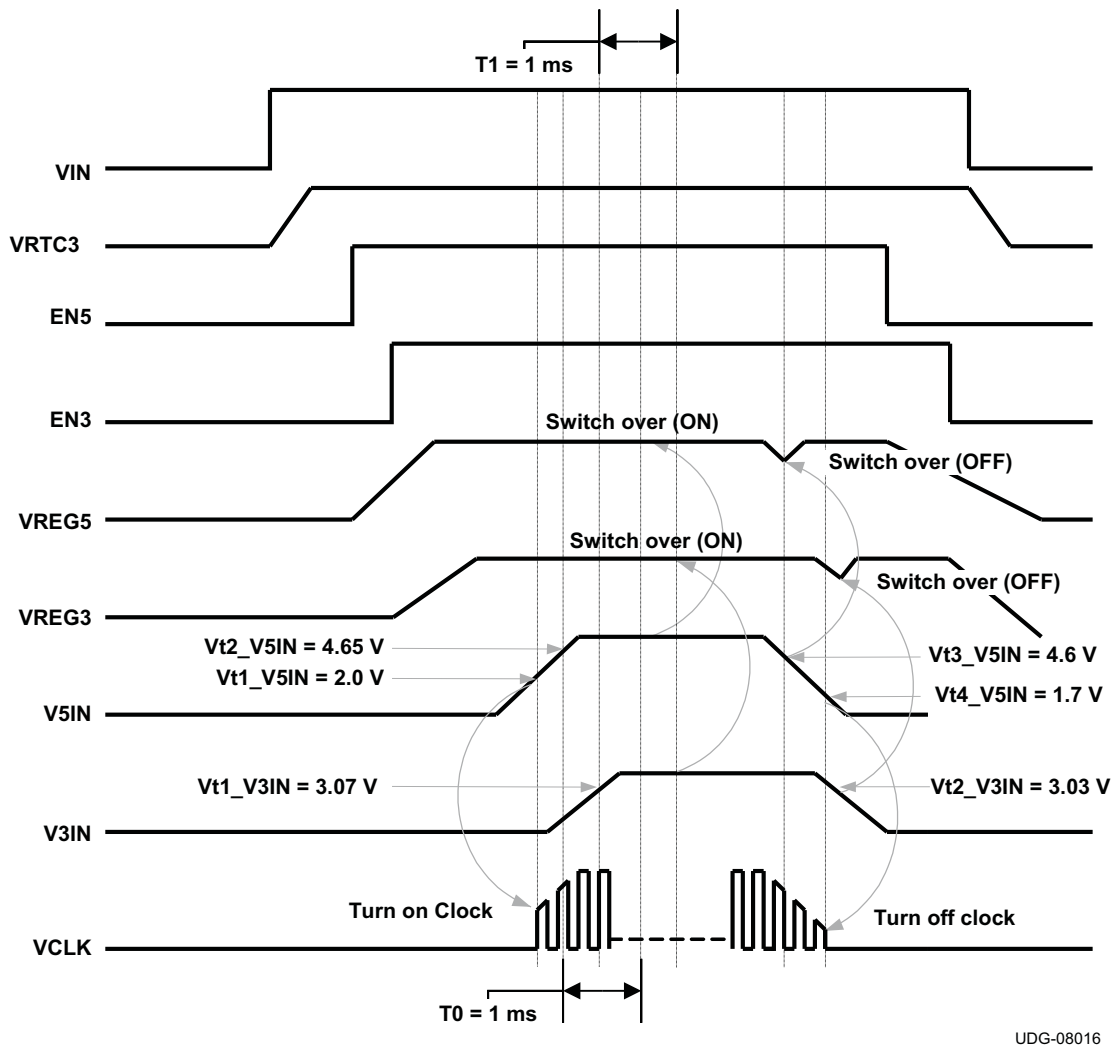

UDG-08016

Figure 1. Power Sequencing

## DETAILED DESCRIPTION

### GENERAL DESCRIPTION

The TPS51103 integrates three LDOs. The VREG5 and VREG3 can each deliver 100 mA of current. The device includes glitch free switch-over circuits which turn off VREG5 and VREG3 LDOs and switch VREG5 and VREG3 to V5IN and V3IN external power inputs respectively when the external high efficiency 5V and 3.3V power rails are available. It improves overall system efficiency and therefore extends battery life. An additional 5-mA VRTC3 LDO is designed to provide an *always on* feature for the real time clock (RTC). A 5-V clock with 50% duty cycle runs at 250 kHz. It can be used as a simple external charge pump driver to generate a 10-V or 15-V low-current voltage rail (see Figure 2). In the notebook application, the 10 V or 15 V created by this circuit could be used to drive an N-channel MOSFET instead of the traditional P-channel MOSFET load switch. The TPS51103 boosts performance and reduce the cost of load switch.

## VREG5

When EN5 is asserted high, VREG5 supplies 5 V through an LDO from  $V_{IN}$ . Its maximum sourcing current is 100 mA. If EN5 is high and the V5IN voltage becomes higher than 4.65 V, then the VREG5 output is switched over to the V5IN input after a 1-ms delay. In the switched over condition, the LDO is turned off and VREG5 is connected to V5IN through the 1.0- $\Omega$   $R_{DS(on)}$  MOSFET switch. When the V5IN voltage becomes lower than 4.6 V, this MOSFET turns off and 5-V LDO is turned back on immediately. A bypass ceramic capacitor is required to stabilize LDO. The recommended value is between 10  $\mu$ F and 22  $\mu$ F. Place the bypass capacitor close to the VREG5 pin. When EN5 is asserted low, both the 5-V LDO and switchover circuit are turned off.

## VREG3

When EN3 is asserted high, VREG3 supplies 3.3 V through an LDO from  $V_{IN}$ . Its maximum sourcing current is 100 mA. If EN3 is high and the V3IN voltage becomes higher than 3.07 V, then the VREG3 output is switched over to the V3IN input after a 1-ms delay. In the switched over condition, LDO is turned off and VREG3 is connected to V3IN through the 1.5- $\Omega$   $R_{DS(on)}$  MOSFET switch. When the V3IN voltage becomes lower than 3.03 V, this MOSFET turns off and the 3.3-V LDO is turned back on immediately. A bypass ceramic capacitor is needed to stabilize LDO, recommended value is between 10  $\mu$ F and 22  $\mu$ F. Place the bypass capacitor close to the VREG3 pin. When EN3 is asserted low, both the 3.3-V LDO and the switchover circuit are turned off.

## VRTC3

This 3.3-V low-current auxiliary power source is typically used for the system's RTC bias voltage. It is powered on after  $V_{IN}$  is applied. A ceramic capacitor with a value between 1  $\mu$ F and 2.2  $\mu$ F placed close to the VRTC3 pin is needed to stabilize the LDO.

## VCLK OUTPUT

When the V5IN voltage becomes higher than 2.0 V, the internal 250-kHz clock turns on and the VCLK pin outputs a 50% duty-cycle clock signal. The voltage swing of VCLK is equal to the GND to V5IN voltage

## THERMAL SHUTDOWN

When the device temperature exceeds the internal threshold value (typically 150C) the TPS51103 shuts off the VREG3, VREG5 and VCLK outputs. This is a non-latch protection.

## THERMAL DESIGN

The thermal performance greatly depends on the printed circuit board (PCB) layout. The TPS51103 is housed in a thermally-enhanced PowerPAD™ package that has an exposed die pad underneath the body. For improved thermal performance, this die pad must be attached to ground via thermal land on the PCB. This ground trace acts as a heatsink and a heat spreader. For further information regarding the PowerPAD™ package and the recommended board layout, refer to the PowerPAD™ package application note ([SLMA002](#)). This document is available at [www.ti.com](http://www.ti.com).

## LAYOUT GUIDELINES

Consider the following points before starting the TPS51103 layout design.

- The input bypass capacitor for  $V_{IN}$  should be placed as close as possible to the pin with short and wide connection.
- The output capacitors for VREG5, VREG3 and VRTC3 should be placed close to the pins with short and wide connections.
- In order to effectively remove heat from the package, properly prepare the thermal land. Apply solder directly to the package thermal pad. Wide copper traces connected to the thermal land help to dissipate heat. Numerous 0.33 mm diameter vias are connected from the thermal land to the internal and/or solder-side system ground plane(s) can also be used to help dissipation.
- The GND pin, output capacitors for VREG5, VREG3 and VRTC3 should be connected to the internal and/or solder-side system ground plane(s) with multiple vias. Use as many vias as possible to reduce the impedance between them and the system ground plane.

APPLICATION INFORMATION

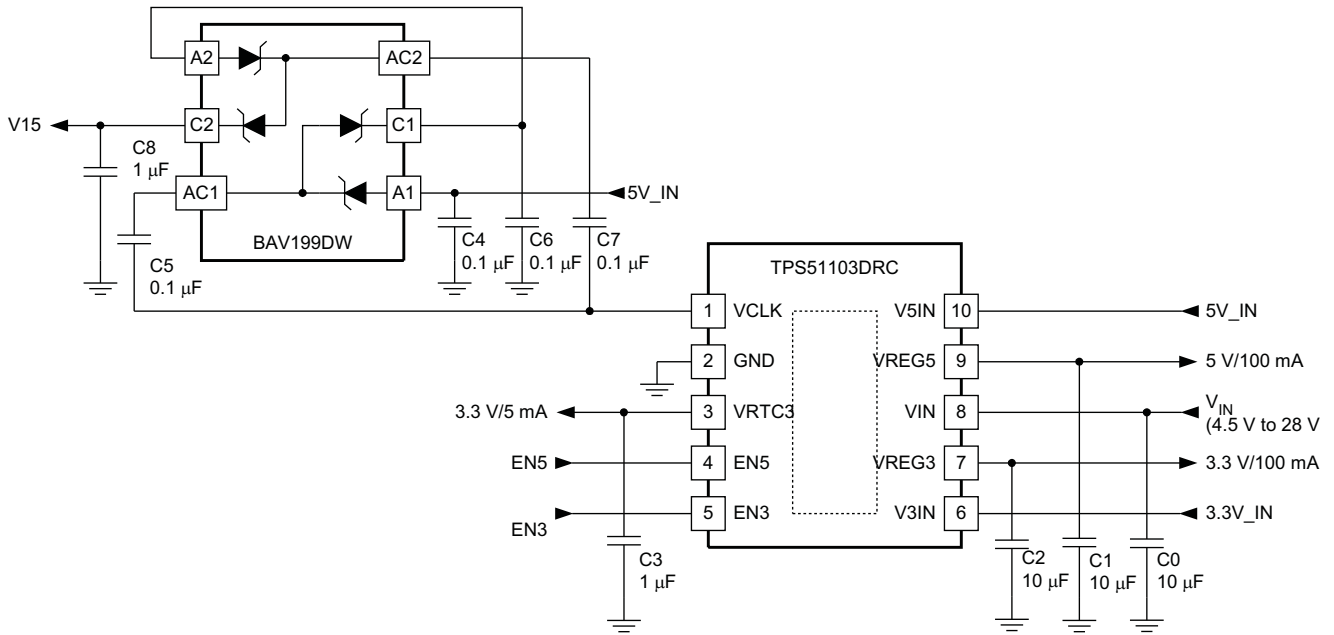

UDG-08101

Figure 2. Typical Application



TYPICAL CHARACTERISTICS

INPUT CURRENT  
vs  
INPUT VOLTAGE

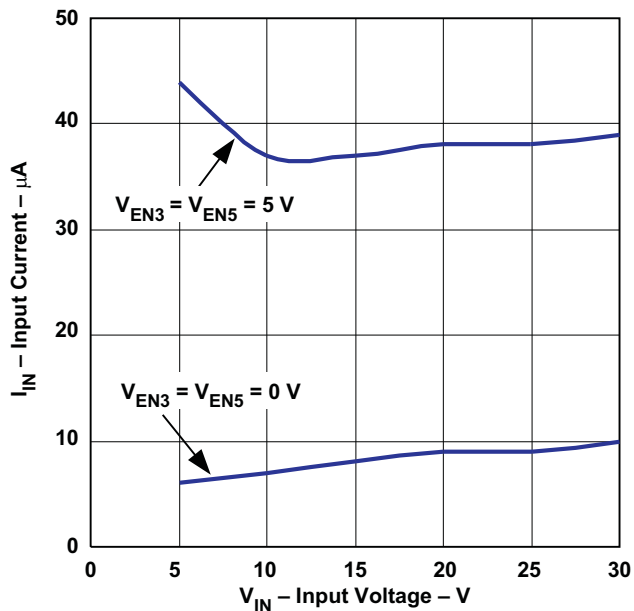

Figure 3.

VREG3 LDO OUTPUT VOLTAGE  
vs  
LDO OUTPUT CURRENT

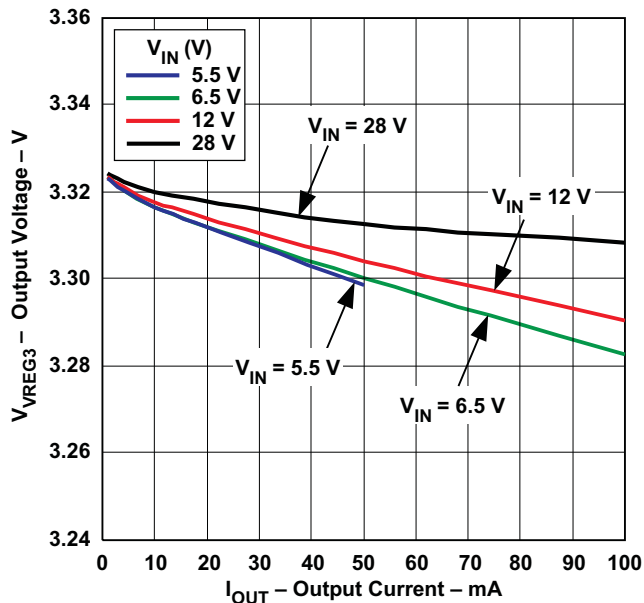

Figure 4.

VREG5 LDO OUTPUT VOLTAGE  
vs  
LDO OUTPUT CURRENT

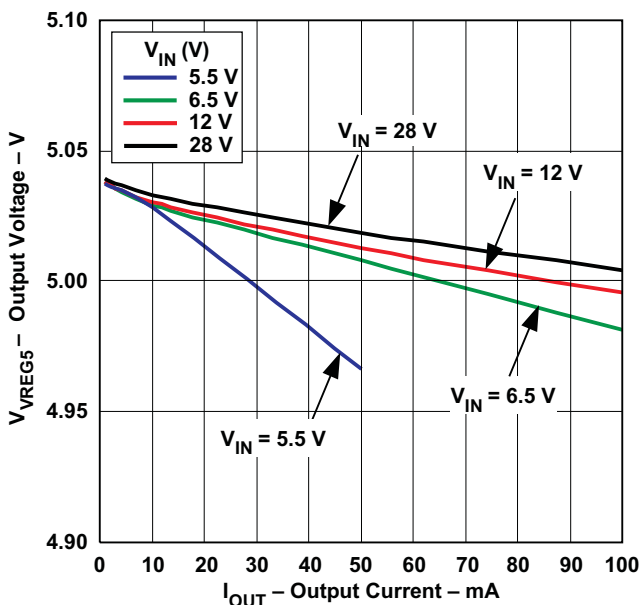

Figure 5.

CHARGE PUMP OUTPUT VOLTAGE  
vs  
CHARGE PUMP OUTPUT CURRENT

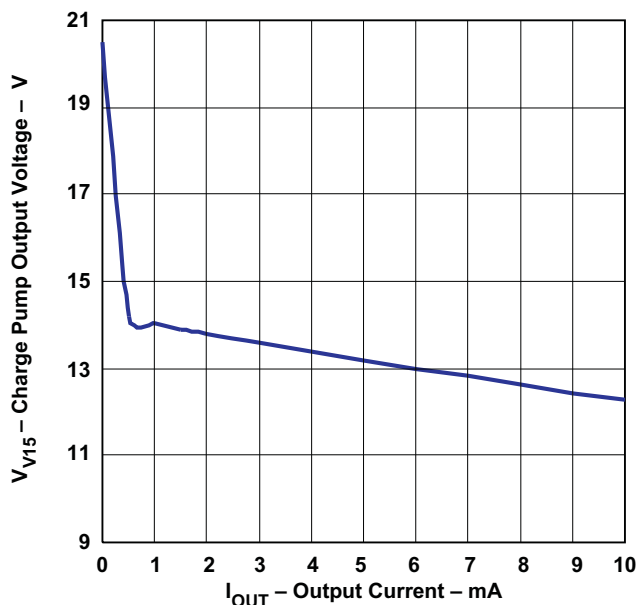

Figure 6.

TYPICAL CHARACTERISTICS (continued)

ALWAYS ON OUTPUT VOLTAGE  
vs  
ALWAYS ON OUTPUT CURRENT

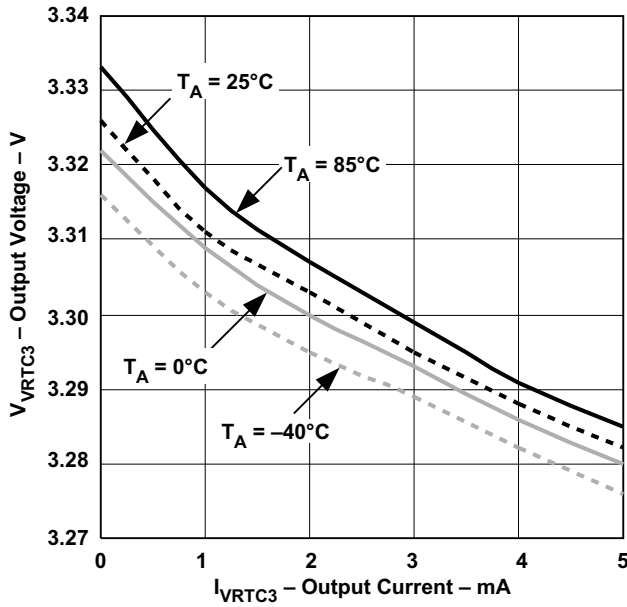

Figure 7.

VREG5 SWITCHOVER OUTPUT VOLTAGE  
vs  
VREG5 SWITCHOVER OUTPUT CURRENT

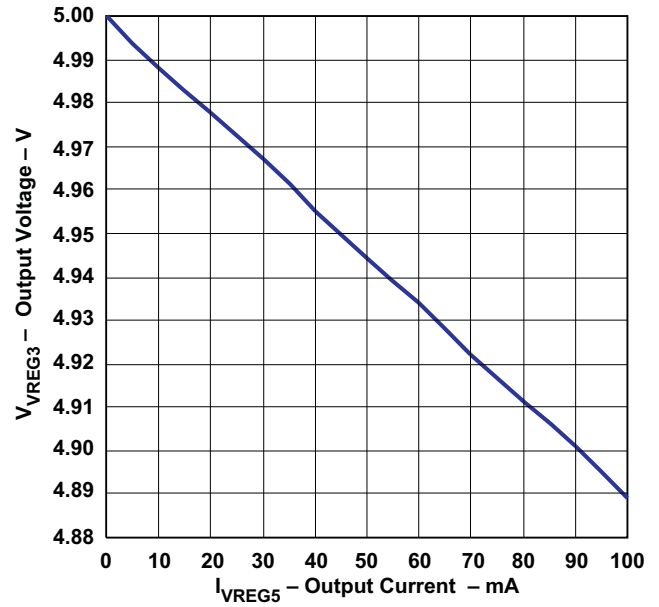

Figure 8.

VREG3 SWITCHOVER OUTPUT VOLTAGE  
vs  
VREG3 SWITCHOVER OUTPUT CURRENT

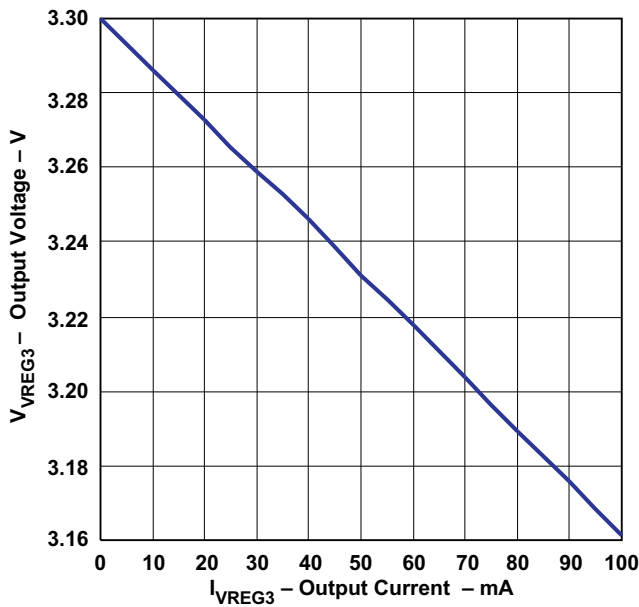

Figure 9.

INPUT CURRENT  
vs  
JUNCTION TEMPERATURE

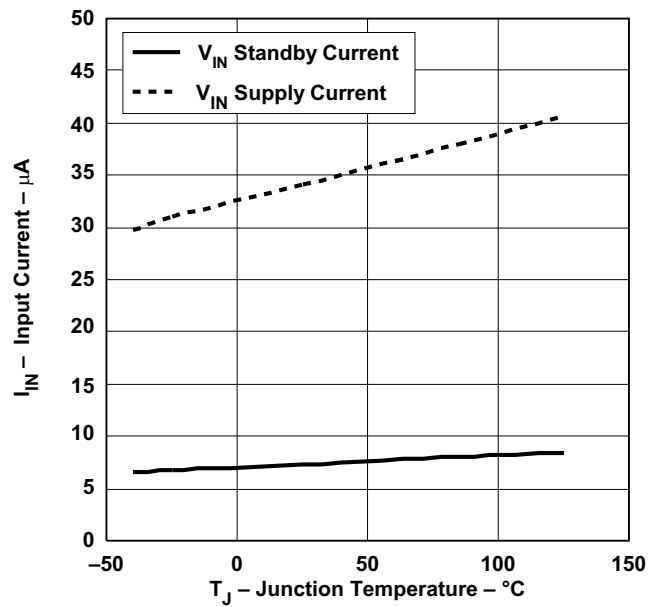

Figure 10.

TYPICAL CHARACTERISTICS (continued)

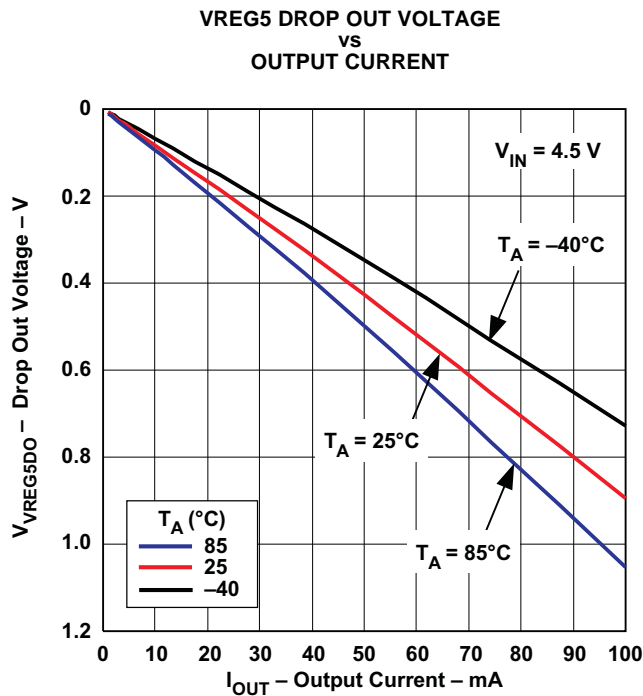

Figure 11.

**PACKAGING INFORMATION**

Orderable part number	Status (1)	Material type (2)	Package   Pins	Package qty   Carrier	RoHS (3)	Lead finish/ Ball material (4)	MSL rating/ Peak reflow (5)	Op temp (°C)	Part marking (6)
<a href="#">TPS51103DRCR</a>	Obsolete	Production	VSON (DRC)   10	-	-	Call TI	Call TI	-40 to 85	1103
<a href="#">TPS51103DRCT</a>	Active	Production	VSON (DRC)   10	250   SMALL T&R	Yes	NIPDAU	Level-2-260C-1 YEAR	-40 to 85	1103
TPS51103DRCT.A	Active	Production	VSON (DRC)   10	250   SMALL T&R	Yes	NIPDAU	Level-2-260C-1 YEAR	-40 to 85	1103

**(1) Status:** For more details on status, see our [product life cycle](#).

**(2) Material type:** When designated, preproduction parts are prototypes/experimental devices, and are not yet approved or released for full production. Testing and final process, including without limitation quality assurance, reliability performance testing, and/or process qualification, may not yet be complete, and this item is subject to further changes or possible discontinuation. If available for ordering, purchases will be subject to an additional waiver at checkout, and are intended for early internal evaluation purposes only. These items are sold without warranties of any kind.

**(3) RoHS values:** Yes, No, RoHS Exempt. See the [TI RoHS Statement](#) for additional information and value definition.

**(4) Lead finish/Ball material:** Parts may have multiple material finish options. Finish options are separated by a vertical ruled line. Lead finish/Ball material values may wrap to two lines if the finish value exceeds the maximum column width.

**(5) MSL rating/Peak reflow:** The moisture sensitivity level ratings and peak solder (reflow) temperatures. In the event that a part has multiple moisture sensitivity ratings, only the lowest level per JEDEC standards is shown. Refer to the shipping label for the actual reflow temperature that will be used to mount the part to the printed circuit board.

**(6) Part marking:** There may be an additional marking, which relates to the logo, the lot trace code information, or the environmental category of the part.

Multiple part markings will be inside parentheses. Only one part marking contained in parentheses and separated by a "-" will appear on a part. If a line is indented then it is a continuation of the previous line and the two combined represent the entire part marking for that device.

**Important Information and Disclaimer:** The information provided on this page represents TI's knowledge and belief as of the date that it is provided. TI bases its knowledge and belief on information provided by third parties, and makes no representation or warranty as to the accuracy of such information. Efforts are underway to better integrate information from third parties. TI has taken and continues to take reasonable steps to provide representative and accurate information but may not have conducted destructive testing or chemical analysis on incoming materials and chemicals. TI and TI suppliers consider certain information to be proprietary, and thus CAS numbers and other limited information may not be available for release.

In no event shall TI's liability arising out of such information exceed the total purchase price of the TI part(s) at issue in this document sold by TI to Customer on an annual basis.

**TAPE AND REEL INFORMATION**

**QUADRANT ASSIGNMENTS FOR PIN 1 ORIENTATION IN TAPE**

\*All dimensions are nominal

Device	Package Type	Package Drawing	Pins	SPQ	Reel Diameter (mm)	Reel Width W1 (mm)	A0 (mm)	B0 (mm)	K0 (mm)	P1 (mm)	W (mm)	Pin1 Quadrant
TPS51103DRCT	VSON	DRC	10	250	180.0	12.4	3.3	3.3	1.1	8.0	12.0	Q2

**TAPE AND REEL BOX DIMENSIONS**

\*All dimensions are nominal

Device	Package Type	Package Drawing	Pins	SPQ	Length (mm)	Width (mm)	Height (mm)
TPS51103DRCT	VSON	DRC	10	250	213.0	191.0	35.0

## GENERIC PACKAGE VIEW

**DRC 10**

**VSON - 1 mm max height**

3 x 3, 0.5 mm pitch

PLASTIC SMALL OUTLINE - NO LEAD

This image is a representation of the package family, actual package may vary.  
Refer to the product data sheet for package details.

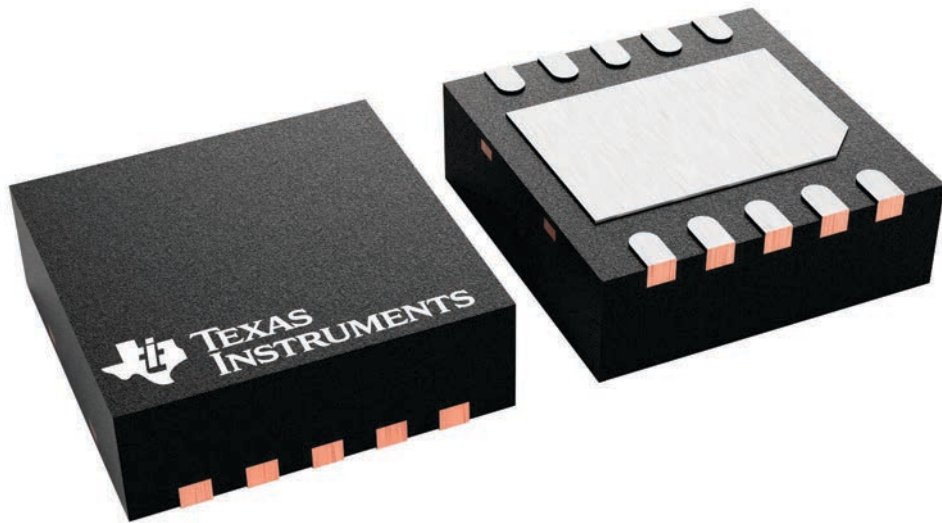

4226193/A

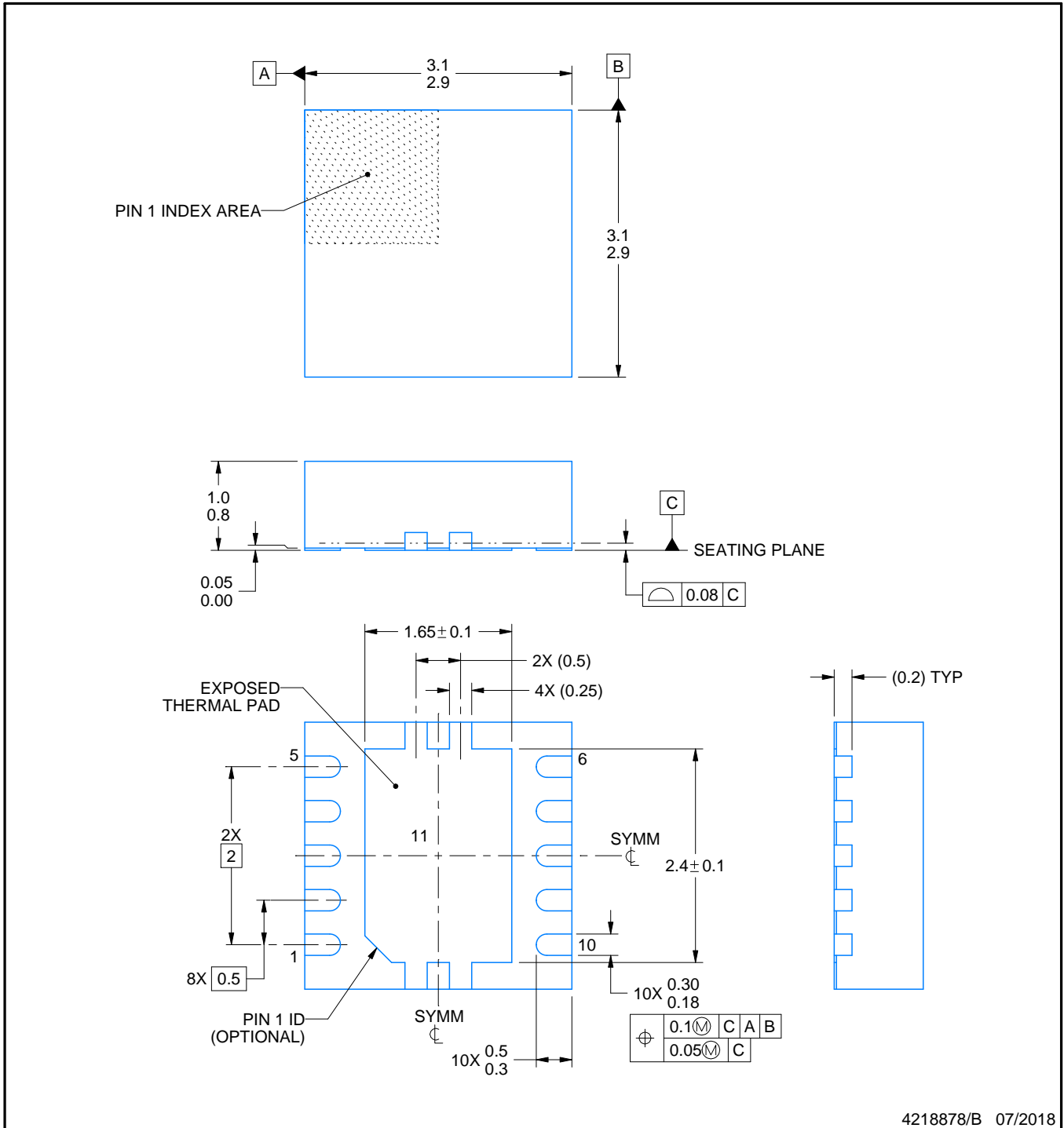

4218878/B 07/2018

NOTES:

1. All linear dimensions are in millimeters. Any dimensions in parenthesis are for reference only. Dimensioning and tolerancing per ASME Y14.5M.
2. This drawing is subject to change without notice.
3. The package thermal pad must be soldered to the printed circuit board for optimal thermal and mechanical performance.



# EXAMPLE BOARD LAYOUT

DRC0010J

VSON - 1 mm max height

PLASTIC SMALL OUTLINE - NO LEAD



LAND PATTERN EXAMPLE  
EXPOSED METAL SHOWN  
SCALE:20X



SOLDER MASK DETAILS

4218878/B 07/2018

NOTES: (continued)

4. This package is designed to be soldered to a thermal pad on the board. For more information, see Texas Instruments literature number SLUA271 ([www.ti.com/lit/sluea271](http://www.ti.com/lit/sluea271)).
5. Vias are optional depending on application, refer to device data sheet. If any vias are implemented, refer to their locations shown on this view. It is recommended that vias under paste be filled, plugged or tented.

# EXAMPLE STENCIL DESIGN

DRC0010J

VSON - 1 mm max height

PLASTIC SMALL OUTLINE - NO LEAD

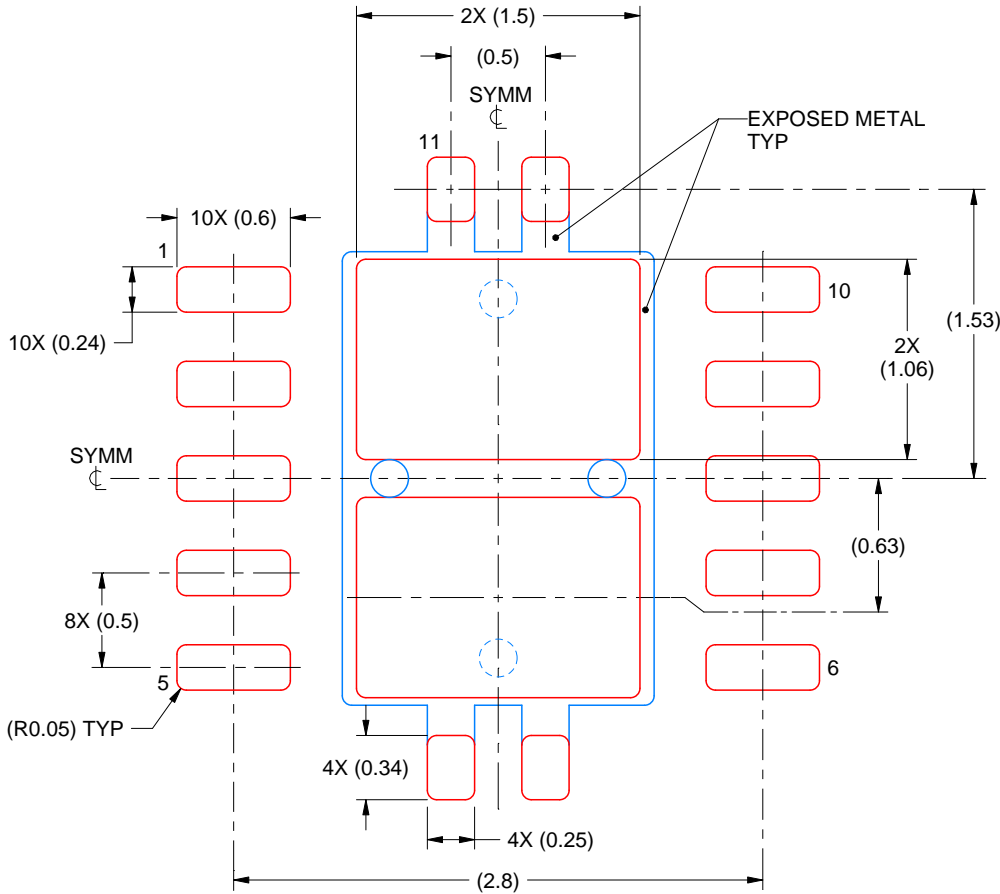

SOLDER PASTE EXAMPLE  
BASED ON 0.125 mm THICK STENCIL

EXPOSED PAD 11:  
80% PRINTED SOLDER COVERAGE BY AREA  
SCALE:25X

4218878/B 07/2018

NOTES: (continued)

6. Laser cutting apertures with trapezoidal walls and rounded corners may offer better paste release. IPC-7525 may have alternate design recommendations.

## IMPORTANT NOTICE AND DISCLAIMER

TI PROVIDES TECHNICAL AND RELIABILITY DATA (INCLUDING DATASHEETS), DESIGN RESOURCES (INCLUDING REFERENCE DESIGNS), APPLICATION OR OTHER DESIGN ADVICE, WEB TOOLS, SAFETY INFORMATION, AND OTHER RESOURCES "AS IS" AND WITH ALL FAULTS, AND DISCLAIMS ALL WARRANTIES, EXPRESS AND IMPLIED, INCLUDING WITHOUT LIMITATION ANY IMPLIED WARRANTIES OF MERCHANTABILITY, FITNESS FOR A PARTICULAR PURPOSE OR NON-INFRINGEMENT OF THIRD PARTY INTELLECTUAL PROPERTY RIGHTS.

These resources are intended for skilled developers designing with TI products. You are solely responsible for (1) selecting the appropriate TI products for your application, (2) designing, validating and testing your application, and (3) ensuring your application meets applicable standards, and any other safety, security, regulatory or other requirements.

These resources are subject to change without notice. TI grants you permission to use these resources only for development of an application that uses the TI products described in the resource. Other reproduction and display of these resources is prohibited. No license is granted to any other TI intellectual property right or to any third party intellectual property right. TI disclaims responsibility for, and you fully indemnify TI and its representatives against any claims, damages, costs, losses, and liabilities arising out of your use of these resources.

TI's products are provided subject to [TI's Terms of Sale](#), [TI's General Quality Guidelines](#), or other applicable terms available either on [ti.com](http://ti.com) or provided in conjunction with such TI products. TI's provision of these resources does not expand or otherwise alter TI's applicable warranties or warranty disclaimers for TI products. Unless TI explicitly designates a product as custom or customer-specified, TI products are standard, catalog, general purpose devices.

TI objects to and rejects any additional or different terms you may propose.

Copyright © 2025, Texas Instruments Incorporated

Last updated 10/2025