

## Ultra-Small, Low-Input-Voltage, Low $r_{ON}$ Load Switch With Hysteresis Control Input

### 1 Features

- Integrated Single Channel Load Switch
- Input Voltage: 1.5 V to 3.6 V
- ON-Resistance
  - $r_{DS(ON)} = 63 \text{ m}\Omega$  at  $V_{IN} = 3.6 \text{ V}$
  - $r_{DS(ON)} = 69 \text{ m}\Omega$  at  $V_{IN} = 2.5 \text{ V}$
  - $r_{DS(ON)} = 78 \text{ m}\Omega$  at  $V_{IN} = 1.8 \text{ V}$
  - $r_{DS(ON)} = 87 \text{ m}\Omega$  at  $V_{IN} = 1.5 \text{ V}$
- 1-A Maximum Continuous Switch Current
- Integrated Hysteresis Enable Input (ON Pin) Allows Easy Power-Rail Sequencing
- Controlled Slew Rate Option: 26  $\mu\text{s}$  at 3.6 V
- Quick Output Discharge Transistor
- Ultra-Small CSP-4 Package
- ESD Performance Tested Per JESD 22
  - 3000-V Human-Body Model (A114-B, Class II)
  - 1000-V Charged-Device Model (C101)

### 2 Applications

- Battery-Powered Equipment
- Portable Industrial Equipment
- Portable Medical Equipment
- Portable Media Players
- Point-of-Sales Terminals
- GPS Devices
- Digital Cameras
- Portable Instrumentation
- Smart Phones

### 3 Description

The TPS22934 is a small, low ON-resistance ( $r_{ON}$ ) load switch with controlled turnon. The devices contain a P-channel MOSFETs that can operate over an input voltage range of 1.5 V to 3.6 V.

The switch is controlled by an ON/OFF input (ON), which has built-in hysteresis ( $V_{TH+(typ)} = 2.35 \text{ V}$ ) allowing an easy use of TPS22934 in power-rail sequencing applications.

In the TPS22934 a 35- $\Omega$  on-chip load resistor is added for output quick discharge when switch is turned off.

In the TPS22934, the rise time of the device is internally controlled to avoid inrush current. The TPS22934 features a typical rise time of 26  $\mu\text{s}$  with a 3.6-V input.

The the TPS22934 is available in an ultra-small space-saving 4-pin CSP package and is characterized for operation over the free-air temperature range of  $-40^{\circ}\text{C}$  to  $85^{\circ}\text{C}$ .

#### Device Information<sup>(1)</sup>

PART NUMBER	PACKAGE	BODY SIZE (NOM)
TPS22934	DSBGA (4)	0.90 mm x 0.90 mm

(1) For all available packages, see the orderable addendum at the end of the data sheet.

#### Typical Application 1.8-V Power-Rail Sequencing

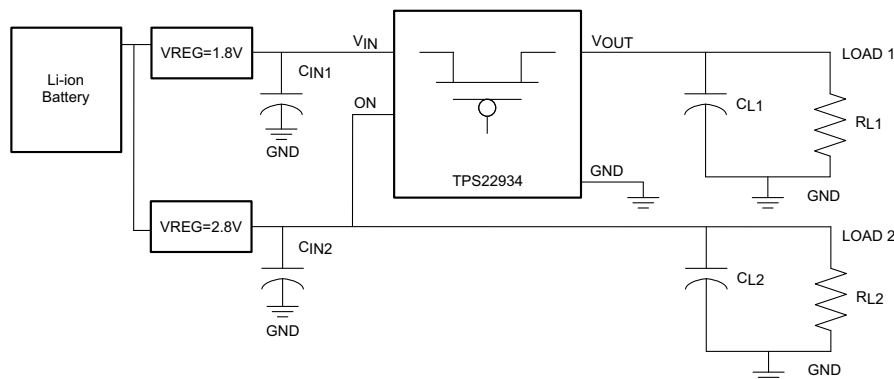

## Table of Contents

<b>1 Features</b> ..... 1 <b>2 Applications</b> ..... 1 <b>3 Description</b> ..... 1 <b>4 Revision History</b> ..... 2 <b>5 Pin Configuration and Functions</b> ..... 3 <b>6 Specifications</b> ..... 4 6.1 Absolute Maximum Ratings ..... 4 6.2 ESD Ratings ..... 4 6.3 Recommended Operating Conditions ..... 4 6.4 Thermal Information ..... 4 6.5 Electrical Characteristics ..... 5 6.6 Switching Characteristics: $V_{IN} = 3.6\text{ V}$ ..... 6 6.7 Switching Characteristics: $V_{IN} = 2.5\text{ V}$ ..... 6 6.8 Switching Characteristics: $V_{IN} = 1.8\text{ V}$ ..... 6 6.9 Switching Characteristics: $V_{IN} = 1.5\text{ V}$ ..... 6 6.10 Typical Characteristics ..... 7 <b>7 Parameter Measurement Information</b> ..... 12 <b>8 Detailed Description</b> ..... 13	8.1 Overview ..... 13 8.2 Functional Block Diagram ..... 13 8.3 Feature Description ..... 13 8.4 Device Functional Modes ..... 14 <b>9 Applications and Implementation</b> ..... 15 9.1 Application Information ..... 15 9.2 Typical Application ..... 16 <b>10 Power Supply Recommendations</b> ..... 17 <b>11 Layout</b> ..... 17 11.1 Layout Guidelines ..... 17 11.2 Layout Example ..... 17 11.3 Thermal Considerations ..... 18 <b>12 Device and Documentation Support</b> ..... 19 12.1 Trademarks ..... 19 12.2 Electrostatic Discharge Caution ..... 19 12.3 Glossary ..... 19 <b>13 Mechanical, Packaging, and Orderable Information</b> ..... 19
---	---

## 4 Revision History

NOTE: Page numbers for previous revisions may differ from page numbers in the current version.

Changes from Revision A (June 2013) to Revision B	Page
• Added <i>ESD Ratings</i> table, <i>Feature Description</i> section, <i>Device Functional Modes</i> , <i>Application and Implementation</i> section, <i>Power Supply Recommendations</i> section, <i>Layout</i> section, <i>Device and Documentation Support</i> section, and <i>Mechanical, Packaging, and Orderable Information</i> section .....	1
• Moved Operating free-air temperature row from Absolute Maximum Ratings to <i>Recommended Operating Conditions</i> .....	4
• Deleted <i>Dissipation Ratings</i> table and replaced it with <i>Thermal Information</i> table .....	4

Changes from Original (August 2010) to Revision A	Page
• Updated package reference from YZP to YZV throughout document.....	1

## 5 Pin Configuration and Functions

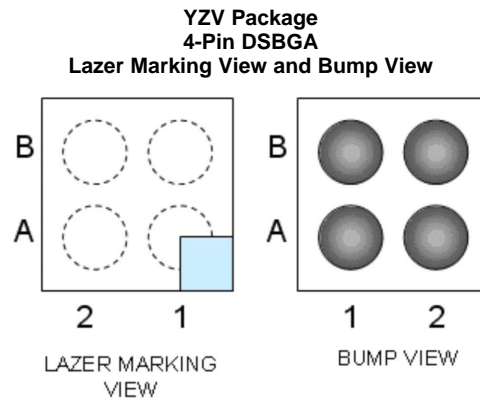

### Pin Functions

PIN		I/O	DESCRIPTION
NO.	NAME		
A1	VOUT	O	Switch output
A2	VIN	I	Switch input, bypass this input with a ceramic capacitor to ground
B1	GND	—	Ground
B2	ON	I	Switch control input, active high. Do not leave floating

**Table 1. Terminals Assignments (YZV Package)**

B	ON	GND
A	VIN	VOUT
	2	1

## 6 Specifications

### 6.1 Absolute Maximum Ratings

over operating free-air temperature range (unless otherwise noted) <sup>(1)</sup>

		MIN	MAX	UNIT
V <sub>IN</sub>	Input voltage	-0.3	4	V
V <sub>OUT</sub>	Output voltage		V <sub>IN</sub> + 0.3	V
V <sub>ON</sub>	Control input voltage	-0.3	4	V
I <sub>MAX</sub>	Maximum continuous switch current, T <sub>A</sub> = -40°C to 85°C		1	A
I <sub>PLS</sub>	Maximum pulsed switch current, 100-μs pulse, 2% duty cycle, T <sub>A</sub> = -40°C to 85°C		1.4	A
T <sub>stg</sub>	Storage temperature	-65	150	°C

- (1) Stresses beyond those listed under *Absolute Maximum Ratings* may cause permanent damage to the device. These are stress ratings only, which do not imply functional operation of the device at these or any other conditions beyond those indicated under *Recommended Operating Conditions*. Exposure to absolute-maximum-rated conditions for extended periods may affect device reliability.

### 6.2 ESD Ratings

		VALUE	UNIT
V <sub>(ESD)</sub>	Electrostatic discharge		
	Human body model (HBM), per ANSI/ESDA/JEDEC JS-001, all pins <sup>(1)</sup>	±3000	V
	Charged device model (CDM), per JEDEC specification JESD22-C101, all pins <sup>(2)</sup>	±1000	

- (1) JEDEC document JEP155 states that 500-V HBM allows safe manufacturing with a standard ESD control process.  
 (2) JEDEC document JEP157 states that 250-V CDM allows safe manufacturing with a standard ESD control process.

### 6.3 Recommended Operating Conditions

		MIN	NOM	MAX	UNIT
V <sub>IN</sub>	Input voltage	1.5		3.6	V
V <sub>ON</sub>	Control input voltage	0		3.6	
V <sub>OUT</sub>	Output voltage			V <sub>IN</sub>	V
C <sub>IN</sub>	Input capacitance	1 <sup>(1)</sup>			μF
T <sub>A</sub>	Operating free-air temperature	-40		85	°C

- (1) See the *Input Capacitor* section in *Application Information*.

### 6.4 Thermal Information

THERMAL METRIC <sup>(1)</sup>		TPS22934	UNIT
		YZV (DSBGA)	
		4 PINS	
R <sub>θJA</sub>	Junction-to-ambient thermal resistance	189.1	°C/W
R <sub>θJC(top)</sub>	Junction-to-case (top) thermal resistance	1.9	
R <sub>θJB</sub>	Junction-to-board thermal resistance	36.8	
Ψ <sub>JT</sub>	Junction-to-top characterization parameter	11.3	
Ψ <sub>JB</sub>	Junction-to-board characterization parameter	36.8	

- (1) For more information about traditional and new thermal metrics, see the *IC Package Thermal Metrics* application report, [SPRA953](#).

## 6.5 Electrical Characteristics

Unless otherwise noted, the specification in the following table applies over the operating ambient temperature  $-40^{\circ}\text{C} \leq T_A \leq 85^{\circ}\text{C}$  (full). Typical values are for  $T_A = 25^{\circ}\text{C}$ .  $V_{IN} = 1.5\text{ V}$  to  $3.6\text{ V}$ .

PARAMETER		TEST CONDITIONS		$T_A$	MIN	TYP <sup>(1)</sup>	MAX	UNIT
$I_{IN}$	Quiescent current	$I_{OUT} = 0, V_{IN} = V_{ON} = 3.6\text{ V}$		Full		3.5	20	$\mu\text{A}$
$I_{IN(OFF)}$	OFF-state supply current	$V_{ON} = \text{GND}, V_{OUT} = 0$		Full		2.5	5	$\mu\text{A}$
$r_{ON}$	ON-state resistance	$I_{OUT} = -200\text{ mA}$	$V_{IN} = 3.6\text{ V}$	25°C		63	77	m $\Omega$
				Full			80	
			$V_{IN} = 2.5\text{ V}$	25°C		69	85	
				Full			89	
			$V_{IN} = 1.8\text{ V}$	25°C		78	96	
				Full			100	
$V_{IN} = 1.5\text{ V}$	25°C		87	107				
	Full			115				
$r_{PD}$	Output pulldown resistance	$V_{IN} = 3.3\text{ V}, V_{ON} < V_{TH+}, I_{OUT} = 30\text{ mA}$		25°C		35	65	$\Omega$
$I_{ON}$	ON input bias current	$V_{ON} = 1.5\text{ V}$ to $3.6\text{ V}$ or GND		Full		0.7	1.5	$\mu\text{A}$
UVLO	Undervoltage lockout	$V_{IN}$ increasing	$V_{ON} = 3.6\text{ V}, I_{OUT} = -100\text{ mA}$	Full	0.8	1.05	1.4	V
		$V_{IN}$ decreasing		Full	0.7	0.95	1.3	
$V_{TH+}$	Positive going ON voltage threshold	$V_{IN} = 1.5\text{ V}$ to $3.6\text{ V}$		Full	2.1	2.35	2.7	V
$V_{TH-}$	Negative going ON voltage threshold	$V_{IN} = 1.5\text{ V}$ to $3.6\text{ V}$		Full	1.3	1.45	1.6	V
$\Delta V_{TH}$	Hysteresis ( $V_{TH+} - V_{TH-}$ )	$V_{IN} = 1.5\text{ V}$ to $3.6\text{ V}$		Full	0.7	0.9	1.1	V

(1) Typical values are at  $V_{IN} = 3.3\text{ V}$  and  $T_A = 25^{\circ}\text{C}$ .

## 6.6 Switching Characteristics: $V_{IN} = 3.6\text{ V}$

 $T_A = 25^\circ\text{C}$  (unless otherwise noted)

PARAMETER		TEST CONDITIONS	MIN	TYP	MAX	UNIT
$t_{ON}$	Turnon time	$R_L = 500\ \Omega$ , $C_L = 0.1\ \mu\text{F}$		33		$\mu\text{s}$
$t_{OFF}$	Turnoff time	$R_L = 500\ \Omega$ , $C_L = 0.1\ \mu\text{F}$		17		$\mu\text{s}$
$t_r$	$V_{OUT}$ rise time	$R_L = 500\ \Omega$ , $C_L = 0.1\ \mu\text{F}$		26		$\mu\text{s}$
$t_f$	$V_{OUT}$ fall time	$R_L = 500\ \Omega$ , $C_L = 0.1\ \mu\text{F}$		7.5		$\mu\text{s}$

## 6.7 Switching Characteristics: $V_{IN} = 2.5\text{ V}$

 $T_A = 25^\circ\text{C}$  (unless otherwise noted)

PARAMETER		TEST CONDITIONS	MIN	TYP	MAX	UNIT
$t_{ON}$	Turnon time	$R_L = 500\ \Omega$ , $C_L = 0.1\ \mu\text{F}$		42		$\mu\text{s}$
$t_{OFF}$	Turnoff time	$R_L = 500\ \Omega$ , $C_L = 0.1\ \mu\text{F}$		17		$\mu\text{s}$
$t_r$	$V_{OUT}$ rise time	$R_L = 500\ \Omega$ , $C_L = 0.1\ \mu\text{F}$		31		$\mu\text{s}$
$t_f$	$V_{OUT}$ fall time	$R_L = 500\ \Omega$ , $C_L = 0.1\ \mu\text{F}$		8		$\mu\text{s}$

## 6.8 Switching Characteristics: $V_{IN} = 1.8\text{ V}$

 $T_A = 25^\circ\text{C}$  (unless otherwise noted)

PARAMETER		TEST CONDITIONS	MIN	TYP	MAX	UNIT
$t_{ON}$	Turnon time	$R_L = 500\ \Omega$ , $C_L = 0.1\ \mu\text{F}$		54		$\mu\text{s}$
$t_{OFF}$	Turnoff time	$R_L = 500\ \Omega$ , $C_L = 0.1\ \mu\text{F}$		15		$\mu\text{s}$
$t_r$	$V_{OUT}$ rise time	$R_L = 500\ \Omega$ , $C_L = 0.1\ \mu\text{F}$		37		$\mu\text{s}$
$t_f$	$V_{OUT}$ fall time	$R_L = 500\ \Omega$ , $C_L = 0.1\ \mu\text{F}$		10		$\mu\text{s}$

## 6.9 Switching Characteristics: $V_{IN} = 1.5\text{ V}$

 $T_A = 25^\circ\text{C}$  (unless otherwise noted)

PARAMETER		TEST CONDITIONS	MIN	TYP	MAX	UNIT
$t_{ON}$	Turnon time	$R_L = 500\ \Omega$ , $C_L = 0.1\ \mu\text{F}$		64		$\mu\text{s}$
$t_{OFF}$	Turnoff time	$R_L = 500\ \Omega$ , $C_L = 0.1\ \mu\text{F}$		14		$\mu\text{s}$
$t_r$	$V_{OUT}$ rise time	$R_L = 500\ \Omega$ , $C_L = 0.1\ \mu\text{F}$		42		$\mu\text{s}$
$t_f$	$V_{OUT}$ fall time	$R_L = 500\ \Omega$ , $C_L = 0.1\ \mu\text{F}$		12		$\mu\text{s}$

### 6.10 Typical Characteristics

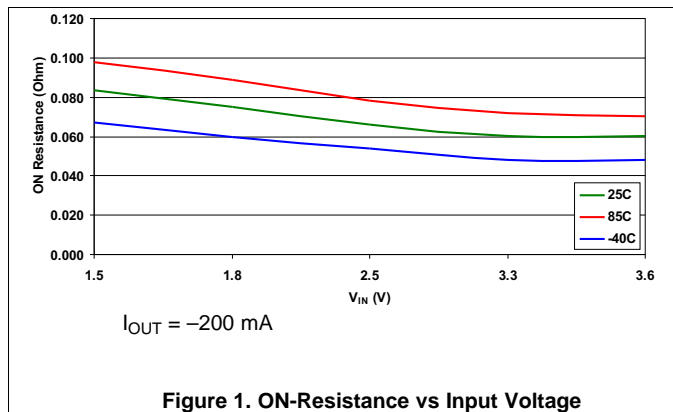

Figure 1. ON-Resistance vs Input Voltage

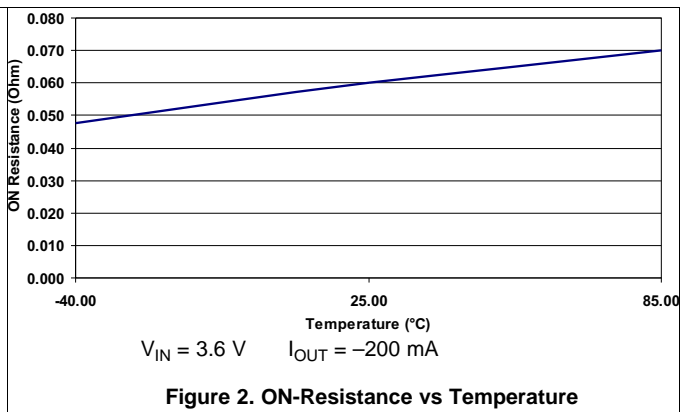

Figure 2. ON-Resistance vs Temperature

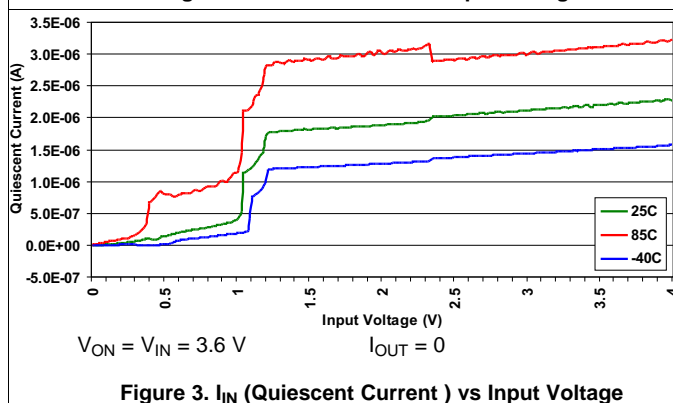

Figure 3.  $I_{IN}$  (Quiescent Current) vs Input Voltage

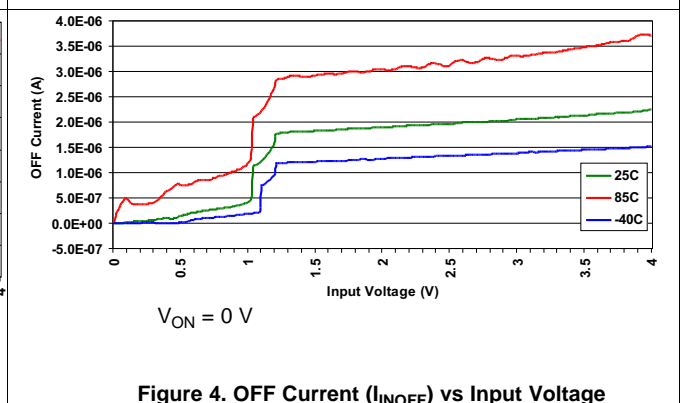

Figure 4. OFF Current ( $I_{INOFF}$ ) vs Input Voltage

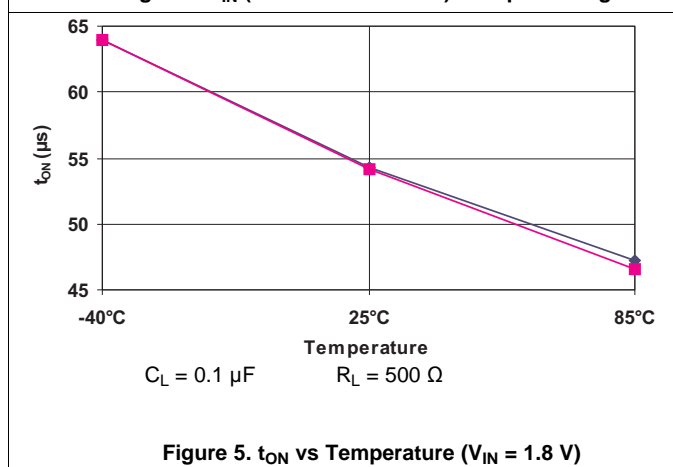

Figure 5.  $t_{ON}$  vs Temperature ( $V_{IN} = 1.8 \text{ V}$ )

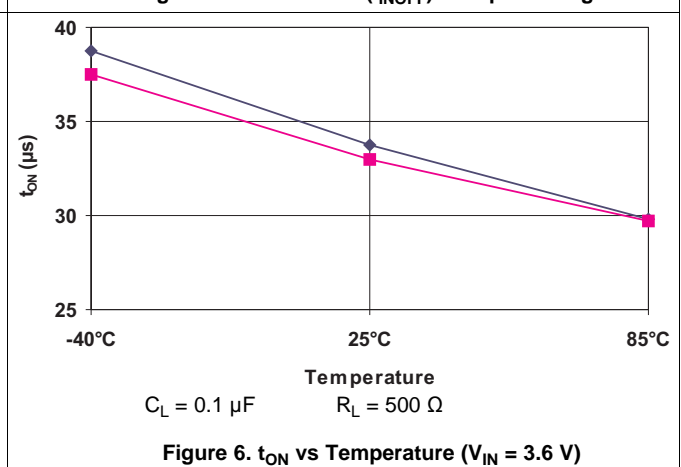
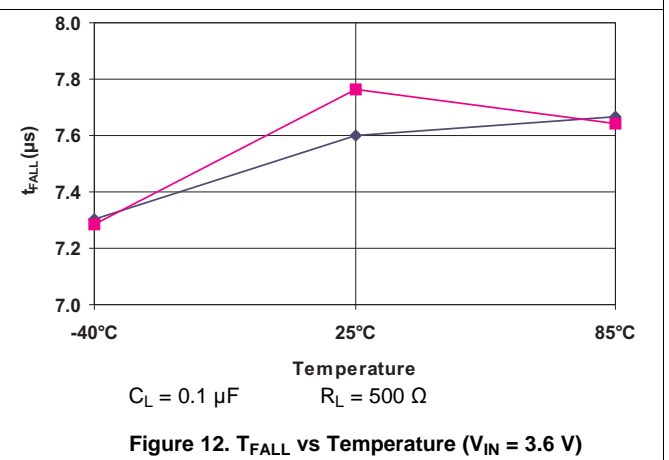
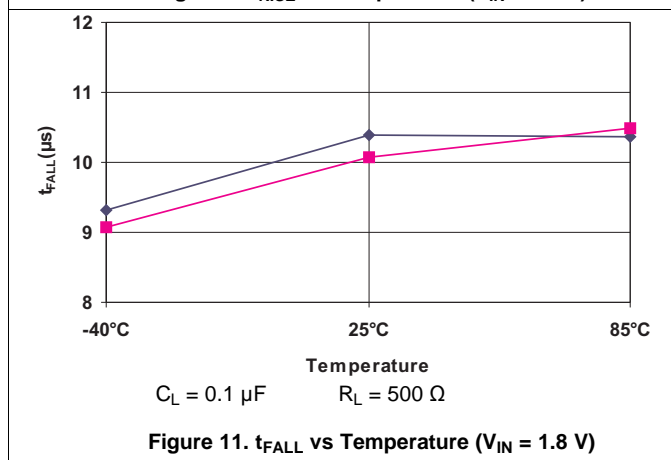
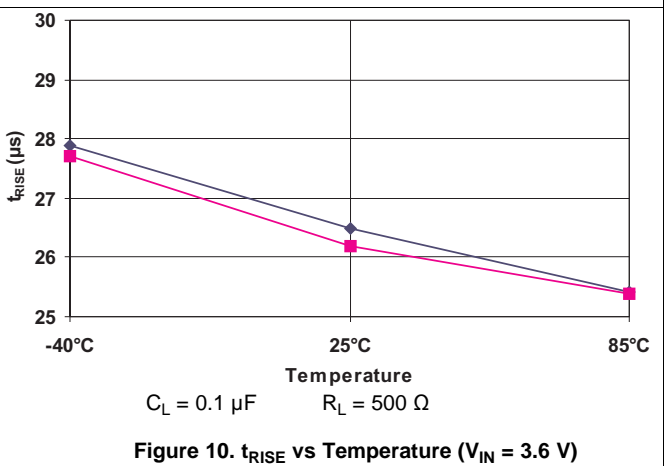
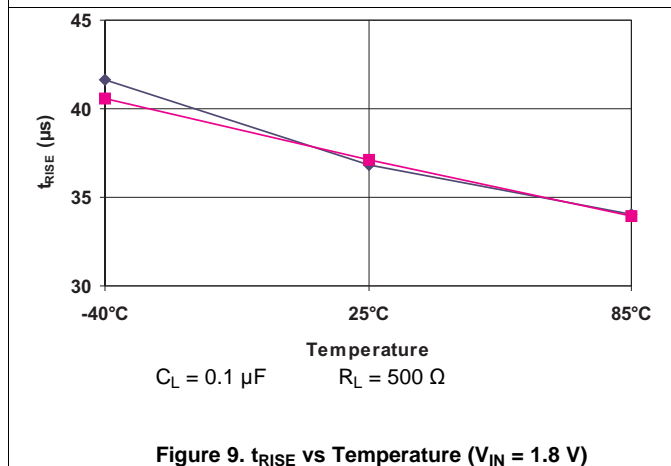
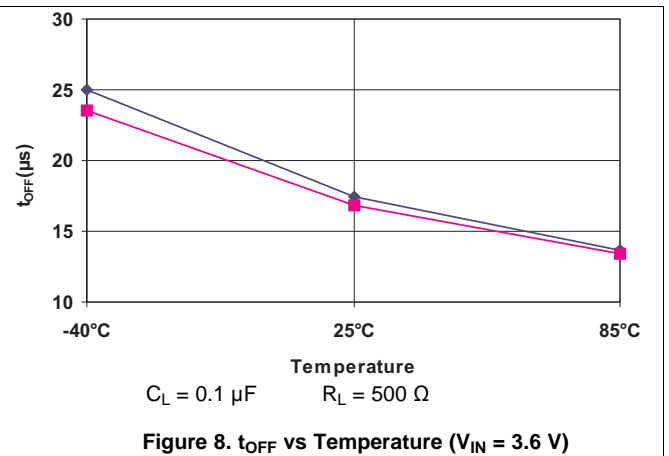
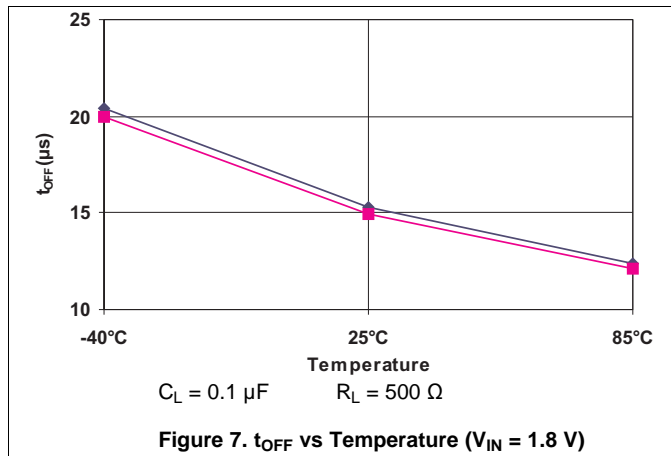

Figure 6.  $t_{ON}$  vs Temperature ( $V_{IN} = 3.6 \text{ V}$ )

Typical Characteristics (continued)



Typical Characteristics (continued)

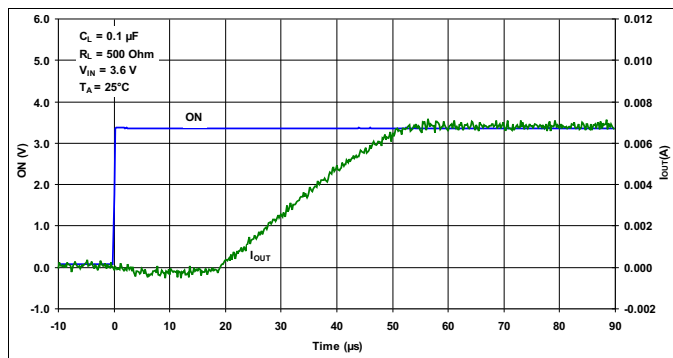

Figure 13. t<sub>ON</sub> Response

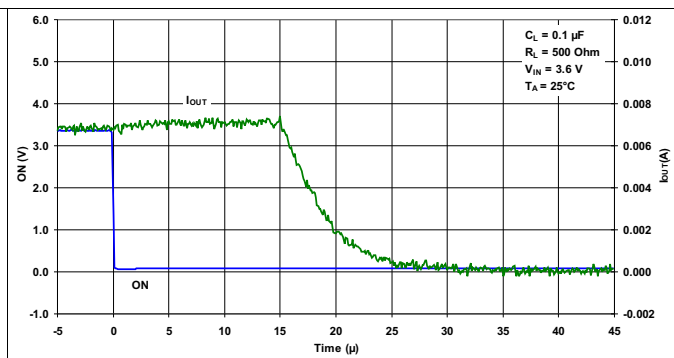

Figure 14. t<sub>OFF</sub> Response

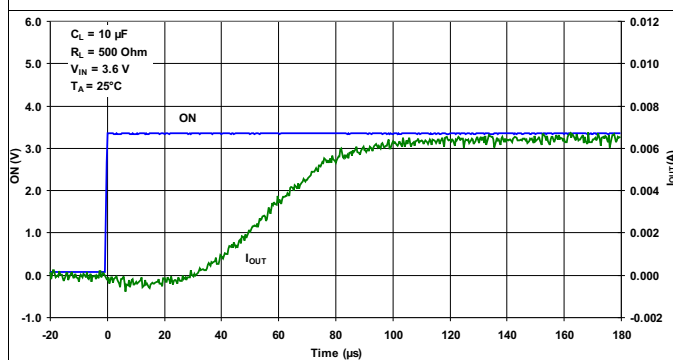

Figure 15. t<sub>ON</sub> Response

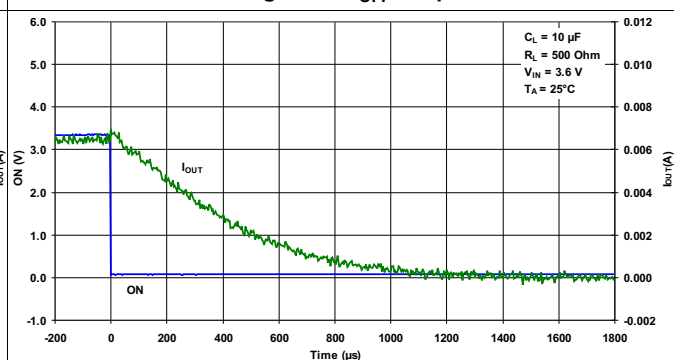

Figure 16. t<sub>OFF</sub> Response

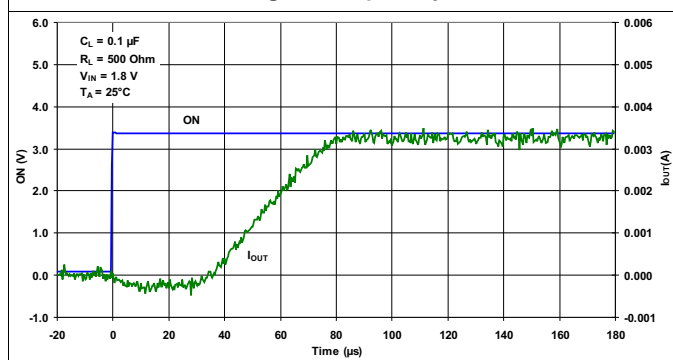

Figure 17. t<sub>ON</sub> Response

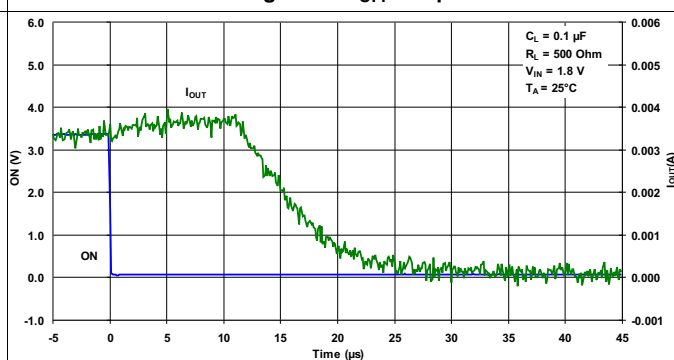
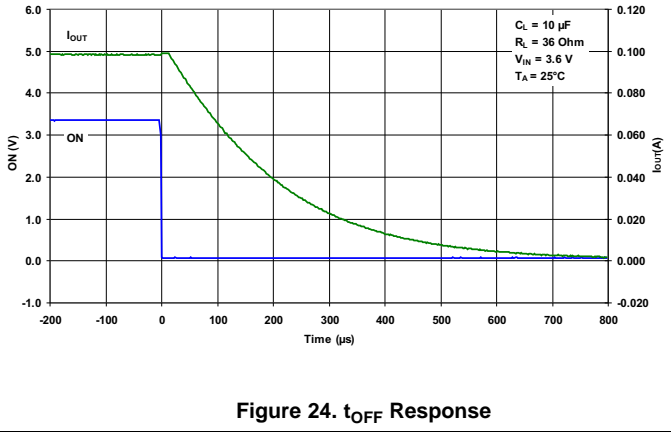
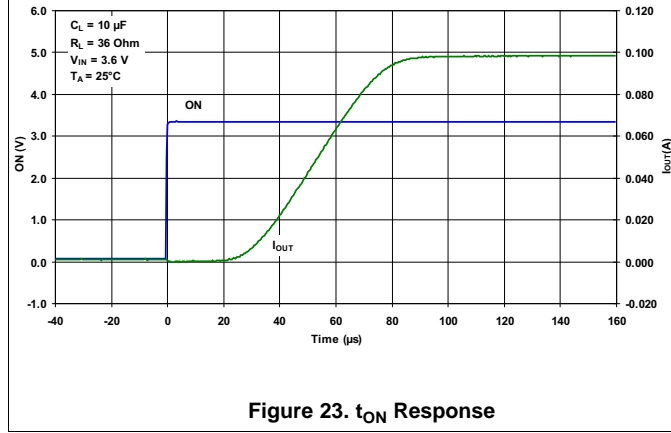
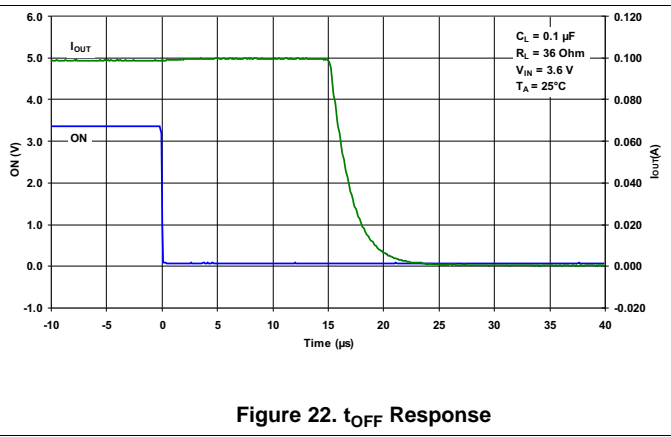
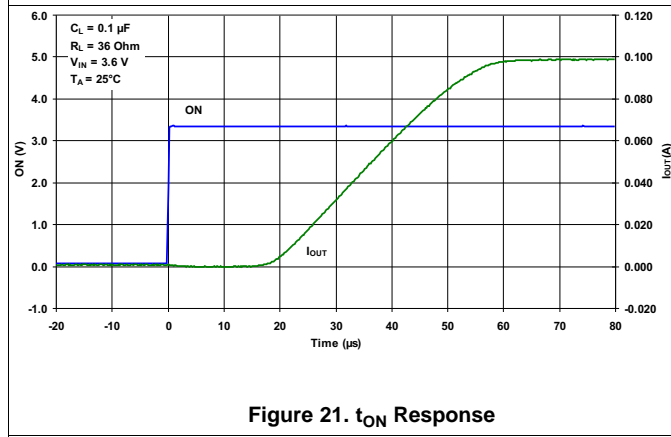
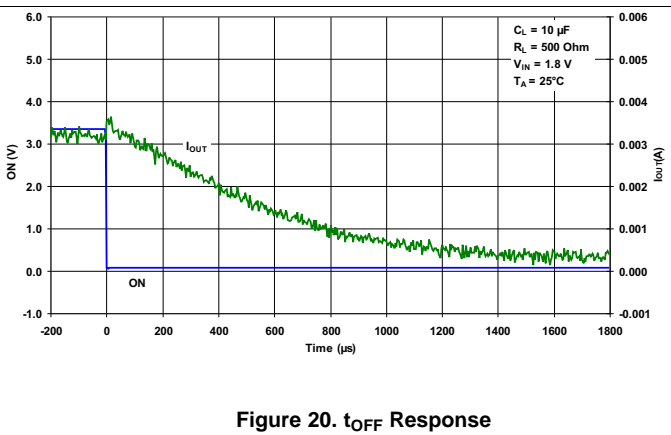
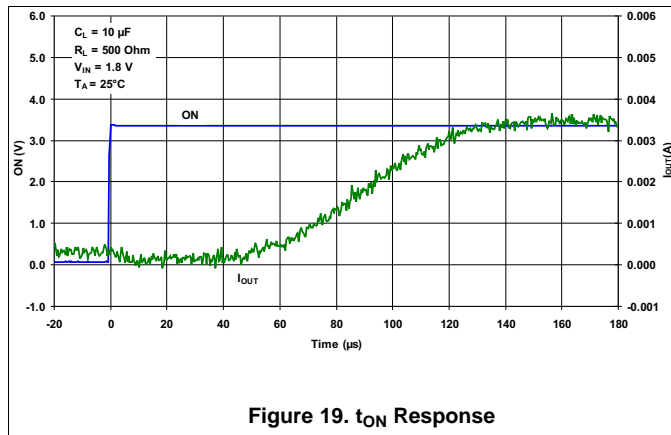

Figure 18. t<sub>OFF</sub> Response

Typical Characteristics (continued)



Typical Characteristics (continued)

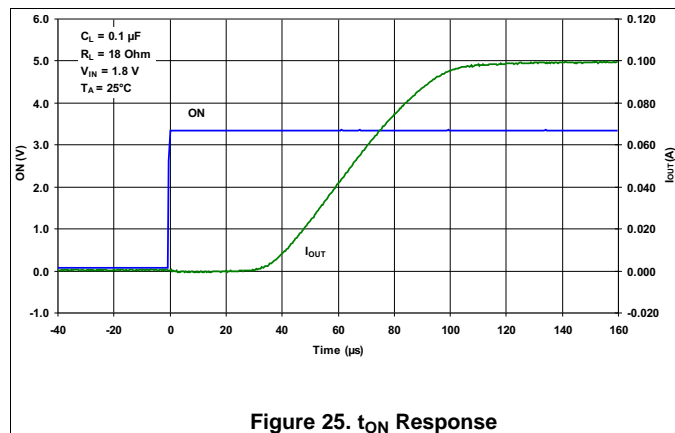

Figure 25.  $t_{ON}$  Response

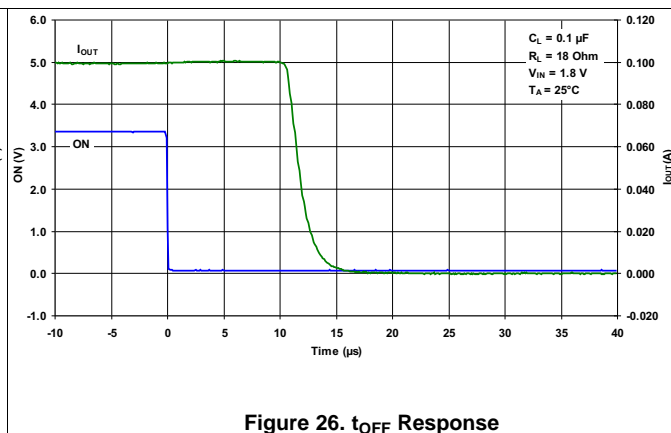

Figure 26.  $t_{OFF}$  Response

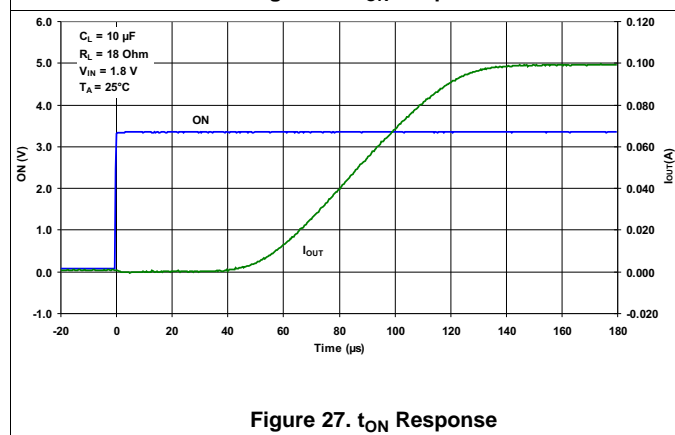

Figure 27.  $t_{ON}$  Response

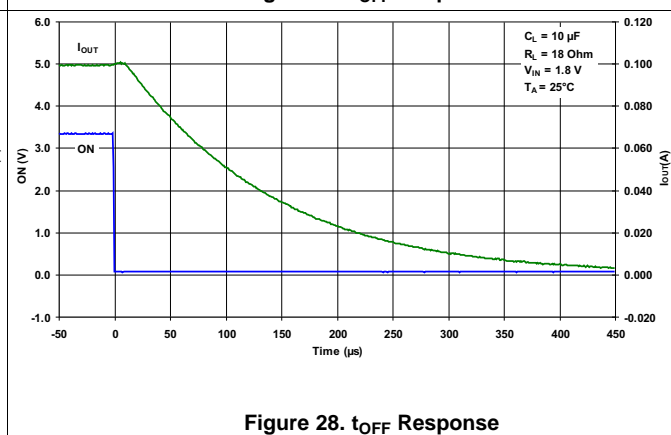
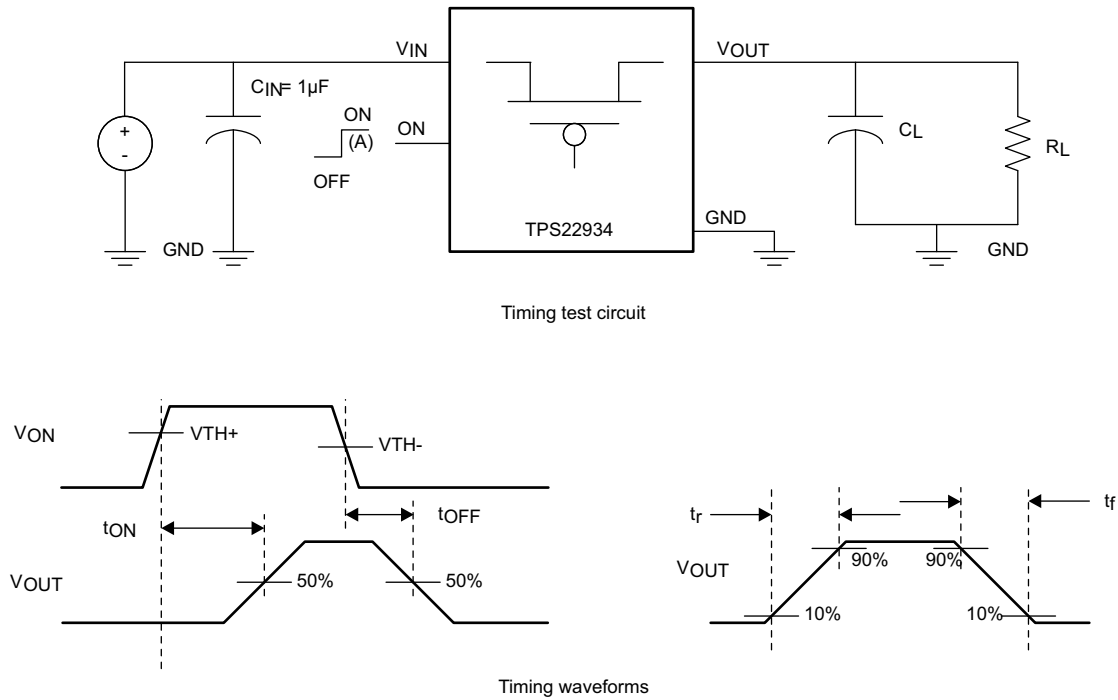

Figure 28.  $t_{OFF}$  Response

## 7 Parameter Measurement Information



- A. Rise and fall times of the control signal is 100 ns.

**Figure 29. Test Circuit and t<sub>ON</sub>/t<sub>OFF</sub> Waveforms**

## 8 Detailed Description

### 8.1 Overview

The TPS22934 is a single-channel, 1-A load switch in a small, space-saving DSBGA-4 package. These devices implement a P-channel MOSFET to provide a low ON-resistance for a low voltage drop across the device. A controlled rise time is used in applications to limit the inrush current. The switch is controlled by an ON/OFF input (ON), which has built-in hysteresis ( $V_{TH+}(typ) = 2.35\text{ V}$ ) allowing an easy use of TPS22934 in power-rail sequencing applications.

### 8.2 Functional Block Diagram

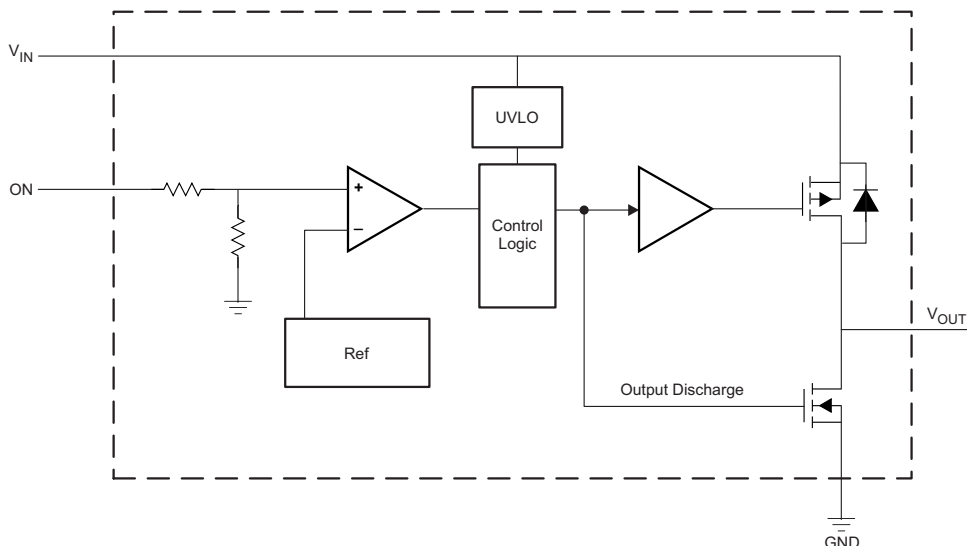

### 8.3 Feature Description

Table 2. Feature List

	$r_{ON}$ (TYP) AT 3.6 V	SLEW RATE (TYP) AT 3.6 V	QUICK OUTPUT DISCHARGE	MAXIMUM OUTPUT CURRENT	ENABLE
TPS22934	63 m $\Omega$	26 $\mu$ s	Yes	1 A	Hysteresis Input $V_{TH+}(typ) = 2.35\text{ V}$

#### 8.3.1 ON and OFF Control

The ON pin controls the state of the switch. The TPS22934 has built-in hysteresis on its control inputs. The load switch is active when the ON voltage is greater than the positive going voltage threshold ( $V_{TH+}$ ). If the ON voltage is lower than the negative going voltage threshold ( $V_{TH-}$ ), then the pass FET is deactivated and the active pulldown from VOUT to GND is activated.

This scenario is ideal for power-rail sequencing applications as shown in Figure 30 where the 2.8-V supply must be valid before the 1.8-V supply turnon.

#### 8.3.2 Undervoltage Lockout

The undervoltage lockout turns off the switch if the input voltage drops below the undervoltage lockout threshold. With the ON pin active, the input voltage rising above the undervoltage lockout threshold causes a controlled turnon of the switch, which limits current overshoots.

### 8.3.3 Quick Output Discharge

The TPS22934 includes the Quick Output Discharge (QOD) feature. When the switch is disabled, a discharge resistance with a typical value of 35  $\Omega$  is connected between the output and ground. This resistance pulls down the output and prevents it from floating when the device is disabled.

## 8.4 Device Functional Modes

**Table 3. Function Table**

ON (Control Signal)	VIN to VOUT	VOUT to GND
$V_{ON} < V_{TH-}$	OFF	ON
$V_{ON} > V_{TH+}$	ON	OFF

## 9 Applications and Implementation

### NOTE

Information in the following applications sections is not part of the TI component specification, and TI does not warrant its accuracy or completeness. TI's customers are responsible for determining suitability of components for their purposes. Customers should validate and test their design implementation to confirm system functionality.

### 9.1 Application Information

The TPS22934 device is a single channel, 1-A load switch supporting VIN in the range of 1.5 to 3.6 V. The ON pin controls the state of the switch. ON pin voltage can be between 0 and 3.6 V. The device has built-in hysteresis on its control input. The load switch is active when ON voltage is greater than the positive going voltage threshold (VTH+). If the ON voltage is lower than the negative going voltage threshold (VTH-), then the pass FET is deactivated and the active pulldown from VOUT to GND is activated.

#### 9.1.1 VIN to VOUT Voltage Drop

The VIN to VOUT voltage drop in the device is determined by the  $R_{ON}$  of the device and the load current. The  $R_{ON}$  of the device depends upon the VIN condition of the device. Refer to the  $R_{ON}$  specification of the device in the Electrical Characteristics table of this data sheet. Once the  $R_{ON}$  of the device is determined based upon the VIN conditions, use [Equation 1](#) to calculate the VIN to VOUT voltage drop:

$$\Delta V = I_{LOAD} \times R_{ON}$$

where

- $\Delta V$  = Voltage drop from VIN to VOUT
- $I_{LOAD}$  = Load current
- $R_{ON}$  = On-resistance of the device for a specific  $V_{IN}$
- An appropriate  $I_{LOAD}$  must be chosen such that the  $I_{MAX}$  specification of the device is not violated. (1)

#### 9.1.2 Input Capacitor

To limit the voltage drop on the input supply caused by transient inrush currents, when the switch turns on into a discharged load capacitor or short-circuit, a capacitor needs to be placed between VIN and GND. A 1- $\mu$ F ceramic capacitor,  $C_{IN}$ , placed close to the pins is usually sufficient. Higher values of  $C_{IN}$  can be used to further reduce the voltage drop.

#### 9.1.3 Output Capacitor

TI recommends a  $C_{IN}$  to  $C_L$  ratio of 10 to 1 for minimizing  $V_{IN}$  dip caused by inrush currents during start-up.

## 9.2 Typical Application

Figure 30 demonstrates how the TPS22934 can be used for power-rail sequencing.

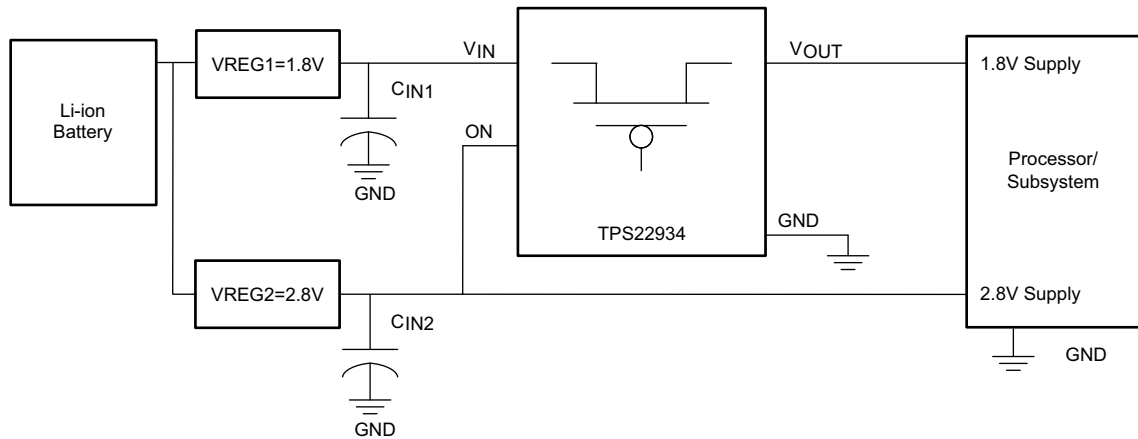

Figure 30. 1.8-V and 2.8-V Power-Rail Sequencing

### 9.2.1 Design Requirements

Table 4. Design Parameters

DESIGN PARAMETER	EXAMPLE VALUE
VREG1	1.8 V
VREG2	2.8 V

### 9.2.2 Detailed Design Procedure

#### 9.2.2.1 Input Capacitor

To limit the voltage drop on the input supply caused by transient in-rush currents when the switch turns on into a discharged load capacitor or short-circuit, a capacitor must be placed between  $V_{IN}$  and GND. A 1- $\mu$ F ceramic capacitor,  $C_{IN}$ , placed close to the pins is usually sufficient. Higher values of  $C_{IN}$  can be used to further reduce the voltage drop. A  $C_{IN}$  to  $C_L$  ratio of 10 to 1 is recommended.

#### 9.2.2.2 Output Capacitor

Due to the integral body diode in the PMOS switch, TI highly recommends a  $C_{IN}$  greater than  $C_L$ . A  $C_L$  greater than  $C_{IN}$  can cause  $V_{OUT}$  to exceed  $V_{IN}$  when the system supply is removed. This could result in current flow through the body diode from  $V_{OUT}$  to  $V_{IN}$ .

### 9.2.3 Application Curve

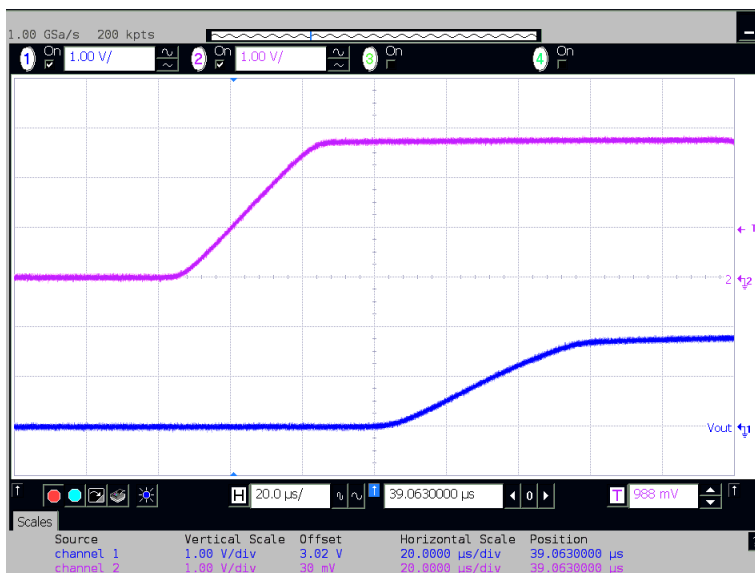

Figure 31. Power-Rail Sequencing of 2.8-V and 1.8-V Rail

## 10 Power Supply Recommendations

The device is designed to operate with a VIN range of 1.5 V to 3.6 V.

## 11 Layout

### 11.1 Layout Guidelines

For best performance, all traces should be as short as possible. To be most effective, the input and output capacitors should be placed close to the device to minimize the effects that parasitic trace inductances may have on normal operation. Using wide traces for VIN, VOUT, and GND helps minimize the parasitic electrical effects along with minimizing the case to ambient thermal impedance.

### 11.2 Layout Example

Figure 32 shows an example for these devices. Notice the connection to system ground between the VOUT Bypass Capacitor ground and the GND pin of the load switch, this creates a ground barrier which helps to reduce the ground noise seen by the device.

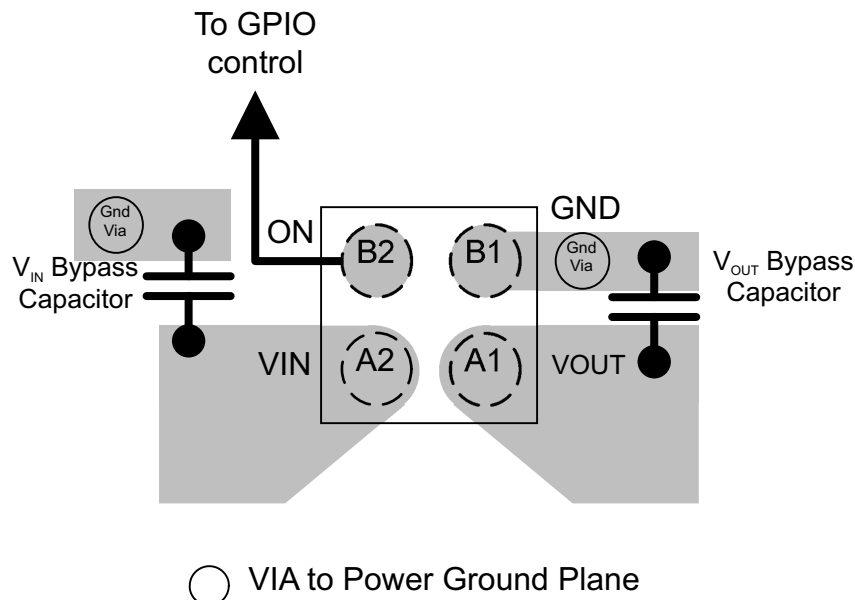
**Layout Example (continued)**

**Figure 32. Recommended Layout Example**
**11.3 Thermal Considerations**

The maximum IC junction temperature should be restricted to 125°C under normal operating conditions. To calculate the maximum allowable dissipation,  $P_{D(max)}$  for a given output current and ambient temperature, use the following equation as a guideline:

$$P_{D(max)} = \frac{T_{J(MAX)} - T_A}{R_{\theta JA}}$$

where

- $P_{D(max)}$  = maximum allowable power dissipation
- $T_{J(max)}$  = maximum allowable junction temperature
- $T_A$  = ambient temperature of the device
- $\theta_{JA}$  = junction to air thermal impedance. See the [Thermal Information](#) section. This parameter is highly dependent upon board layout.

(2)

## 12 Device and Documentation Support

### 12.1 Trademarks

All trademarks are the property of their respective owners.

### 12.2 Electrostatic Discharge Caution



These devices have limited built-in ESD protection. The leads should be shorted together or the device placed in conductive foam during storage or handling to prevent electrostatic damage to the MOS gates.

### 12.3 Glossary

[SLYZ022](#) — *TI Glossary*.

This glossary lists and explains terms, acronyms, and definitions.

## 13 Mechanical, Packaging, and Orderable Information

The following pages include mechanical, packaging, and orderable information. This information is the most current data available for the designated devices. This data is subject to change without notice and revision of this document. For browser-based versions of this data sheet, refer to the left-hand navigation.

**PACKAGING INFORMATION**

Orderable part number	Status (1)	Material type (2)	Package   Pins	Package qty   Carrier	RoHS (3)	Lead finish/ Ball material (4)	MSL rating/ Peak reflow (5)	Op temp (°C)	Part marking (6)
<a href="#">TPS22934YZVR</a>	Active	Production	DSBGA (YZV)   4	3000   LARGE T&R	Yes	SNAGCU	Level-1-260C-UNLIM	-40 to 85	62 N
TPS22934YZVR.A	Active	Production	DSBGA (YZV)   4	3000   LARGE T&R	Yes	SNAGCU	Level-1-260C-UNLIM	-40 to 85	62 N
TPS22934YZVR.B	Active	Production	DSBGA (YZV)   4	3000   LARGE T&R	Yes	SNAGCU	Level-1-260C-UNLIM	-40 to 85	62 N
<a href="#">TPS22934YZVT</a>	Active	Production	DSBGA (YZV)   4	250   SMALL T&R	Yes	SNAGCU	Level-1-260C-UNLIM	-40 to 85	62 N
TPS22934YZVT.A	Active	Production	DSBGA (YZV)   4	250   SMALL T&R	Yes	SNAGCU	Level-1-260C-UNLIM	-40 to 85	62 N
TPS22934YZVT.B	Active	Production	DSBGA (YZV)   4	250   SMALL T&R	Yes	SNAGCU	Level-1-260C-UNLIM	-40 to 85	62 N

<sup>(1)</sup> **Status:** For more details on status, see our [product life cycle](#).

<sup>(2)</sup> **Material type:** When designated, preproduction parts are prototypes/experimental devices, and are not yet approved or released for full production. Testing and final process, including without limitation quality assurance, reliability performance testing, and/or process qualification, may not yet be complete, and this item is subject to further changes or possible discontinuation. If available for ordering, purchases will be subject to an additional waiver at checkout, and are intended for early internal evaluation purposes only. These items are sold without warranties of any kind.

<sup>(3)</sup> **RoHS values:** Yes, No, RoHS Exempt. See the [TI RoHS Statement](#) for additional information and value definition.

<sup>(4)</sup> **Lead finish/Ball material:** Parts may have multiple material finish options. Finish options are separated by a vertical ruled line. Lead finish/Ball material values may wrap to two lines if the finish value exceeds the maximum column width.

<sup>(5)</sup> **MSL rating/Peak reflow:** The moisture sensitivity level ratings and peak solder (reflow) temperatures. In the event that a part has multiple moisture sensitivity ratings, only the lowest level per JEDEC standards is shown. Refer to the shipping label for the actual reflow temperature that will be used to mount the part to the printed circuit board.

<sup>(6)</sup> **Part marking:** There may be an additional marking, which relates to the logo, the lot trace code information, or the environmental category of the part.

Multiple part markings will be inside parentheses. Only one part marking contained in parentheses and separated by a "~" will appear on a part. If a line is indented then it is a continuation of the previous line and the two combined represent the entire part marking for that device.

**Important Information and Disclaimer:** The information provided on this page represents TI's knowledge and belief as of the date that it is provided. TI bases its knowledge and belief on information provided by third parties, and makes no representation or warranty as to the accuracy of such information. Efforts are underway to better integrate information from third parties. TI has taken and continues to take reasonable steps to provide representative and accurate information but may not have conducted destructive testing or chemical analysis on incoming materials and chemicals. TI and TI suppliers consider certain information to be proprietary, and thus CAS numbers and other limited information may not be available for release.

In no event shall TI's liability arising out of such information exceed the total purchase price of the TI part(s) at issue in this document sold by TI to Customer on an annual basis.

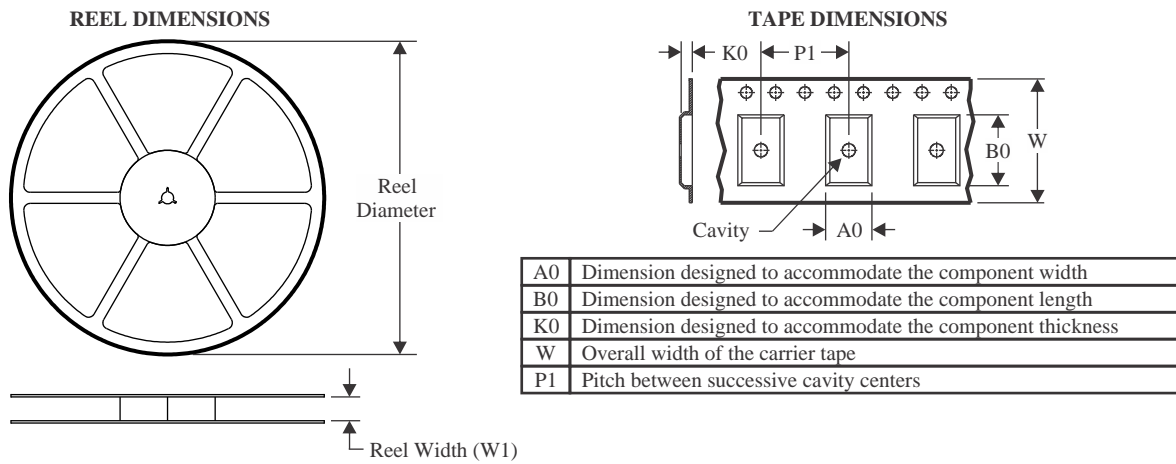
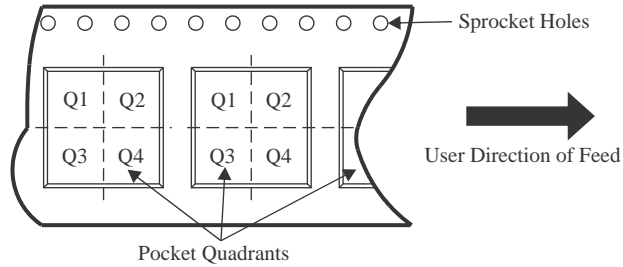
**TAPE AND REEL INFORMATION**

**QUADRANT ASSIGNMENTS FOR PIN 1 ORIENTATION IN TAPE**

\*All dimensions are nominal

Device	Package Type	Package Drawing	Pins	SPQ	Reel Diameter (mm)	Reel Width W1 (mm)	A0 (mm)	B0 (mm)	K0 (mm)	P1 (mm)	W (mm)	Pin1 Quadrant
TPS22934YZVR	DSBGA	YZV	4	3000	178.0	9.2	1.0	1.0	0.63	4.0	8.0	Q1
TPS22934YZVT	DSBGA	YZV	4	250	178.0	9.2	1.0	1.0	0.63	4.0	8.0	Q1

**TAPE AND REEL BOX DIMENSIONS**

\*All dimensions are nominal

Device	Package Type	Package Drawing	Pins	SPQ	Length (mm)	Width (mm)	Height (mm)
TPS22934YZVR	DSBGA	YZV	4	3000	220.0	220.0	35.0
TPS22934YZVT	DSBGA	YZV	4	250	220.0	220.0	35.0

YZV (S-XBGA-N4)

DIE-SIZE BALL GRID ARRAY

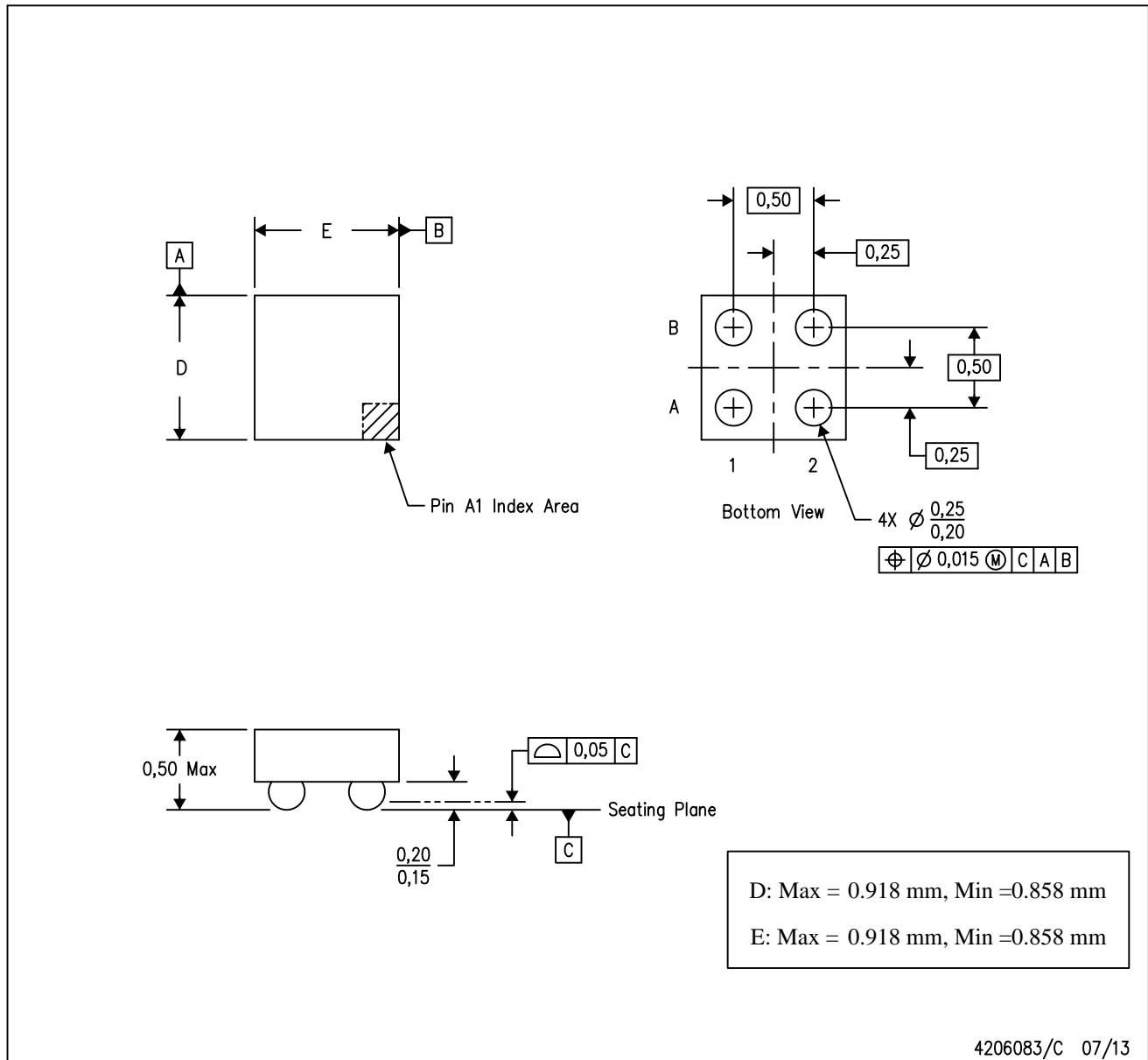

- NOTES:
- A. All linear dimensions are in millimeters. Dimensioning and tolerancing per ASME Y14.5M-1994.
  - B. This drawing is subject to change without notice.
  - C. NanoFree™ package configuration.

NanoFree is a trademark of Texas Instruments.

## IMPORTANT NOTICE AND DISCLAIMER

TI PROVIDES TECHNICAL AND RELIABILITY DATA (INCLUDING DATASHEETS), DESIGN RESOURCES (INCLUDING REFERENCE DESIGNS), APPLICATION OR OTHER DESIGN ADVICE, WEB TOOLS, SAFETY INFORMATION, AND OTHER RESOURCES "AS IS" AND WITH ALL FAULTS, AND DISCLAIMS ALL WARRANTIES, EXPRESS AND IMPLIED, INCLUDING WITHOUT LIMITATION ANY IMPLIED WARRANTIES OF MERCHANTABILITY, FITNESS FOR A PARTICULAR PURPOSE OR NON-INFRINGEMENT OF THIRD PARTY INTELLECTUAL PROPERTY RIGHTS.

These resources are intended for skilled developers designing with TI products. You are solely responsible for (1) selecting the appropriate TI products for your application, (2) designing, validating and testing your application, and (3) ensuring your application meets applicable standards, and any other safety, security, regulatory or other requirements.

These resources are subject to change without notice. TI grants you permission to use these resources only for development of an application that uses the TI products described in the resource. Other reproduction and display of these resources is prohibited. No license is granted to any other TI intellectual property right or to any third party intellectual property right. TI disclaims responsibility for, and you fully indemnify TI and its representatives against any claims, damages, costs, losses, and liabilities arising out of your use of these resources.

TI's products are provided subject to [TI's Terms of Sale](#), [TI's General Quality Guidelines](#), or other applicable terms available either on [ti.com](#) or provided in conjunction with such TI products. TI's provision of these resources does not expand or otherwise alter TI's applicable warranties or warranty disclaimers for TI products. Unless TI explicitly designates a product as custom or customer-specified, TI products are standard, catalog, general purpose devices.

TI objects to and rejects any additional or different terms you may propose.

Copyright © 2026, Texas Instruments Incorporated

Last updated 10/2025