

TLIN1027-Q1 不具有显性状态超时、LIN 收发器

1 特性

- 符合汽车应用要求的 AEC-Q100 标准
 - 温度等级 1：-40°C 至 125°C T_A
 - 器件 HBM 认证等级：±8kV
 - 器件 CDM 认证等级：±1.5kV
- 符合 LIN 2.0、LIN 2.1、LIN 2.2、LIN 2.2 A 和 ISO/DIS 17987 - 4.2 标准 (请参阅“开关特性”)
- 符合适用于 LIN 的 SAE J2602 推荐实践的要求
- 支持 ISO 9141 (K-Line)
- 支持 12V 应用
- LIN 传输数据速率高达 20kbps
- 宽工作范围
 - 4V 至 36V 电源电压
 - ±45V LIN 总线故障保护
- 休眠模式：超低电流消耗允许以下类型的唤醒事件：
 - LIN 总线
 - 通过 EN 引脚的本地唤醒
- 无显性状态超时
- 上电和断电无干扰运行
- 保护特性：
 - V_{SUP} 欠压保护
 - 热关断保护
 - 系统级未供电节点或接地断开失效防护。
- 采用 SOIC (8) 和无引线 VSON (8) 封装，提高了自动光学检测 (AOI) 能力

2 应用

- 车身电子装置和照明
- 信息娱乐系统与仪表盘
- 混合动力电动汽车和动力总成系统
- 被动安全
- 电器

3 说明

TLIN1027-Q1 是一款本地互连网络 (LIN) 物理层收发器，集成了唤醒和保护功能，兼容 LIN 2.0、LIN 2.1、LIN 2.2、LIN 2.2 A 和 ISO/DIS 17987 - 4.2 标准。LIN 是一种单线双向总线，通常用于数据传输速率高达 20kbps 的车载网络。TLIN1027-Q1 旨在为 12V 应用提供支持，具有更宽的工作电压和额外的总线故障保护。

LIN 接收器支持高达 100kbps 的数据传输速率，从而实现更快的内联编程。TLIN1027-Q1 使用一个可降低电磁辐射 (EME) 的限流波形整形驱动器将 TXD 输入上的数据流转化为 LIN 总线信号。接收器将数据流转化为逻辑电平信号，此信号通过开漏 RXD 引脚发送到微处理器。休眠模式可实现超低电流消耗，该模式允许通过 LIN 总线或 EN 引脚实现唤醒。

器件信息

器件型号	封装 ⁽¹⁾	封装尺寸 (标称值)
TLIN1027-Q1	SOIC (D) (8)	4.90mm x 3.91mm
	VSON (DRB) (8)	3.00mm x 3.00mm

(1) 如需了解所有可用封装，请参阅数据表末尾的可订购产品附录。

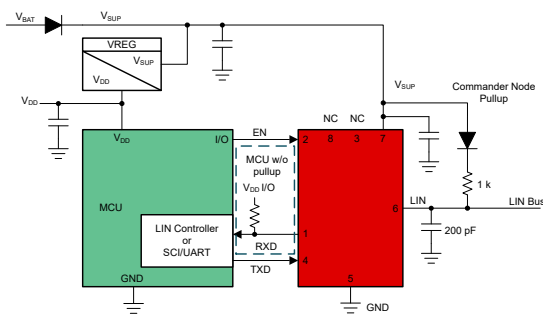

简化版原理图，指挥官模式^{(1)C}

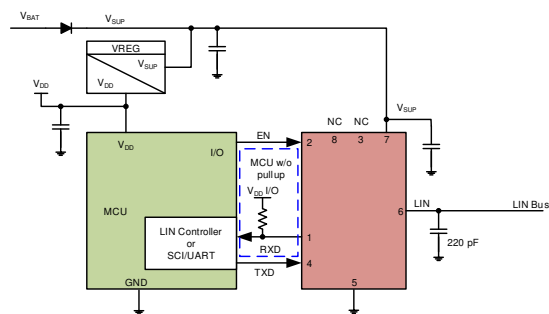

简化版原理图，响应者模式⁽²⁾

Table of Contents

1 特性	1	8.3 Feature Description.....	21
2 应用	1	8.4 Device Functional Modes.....	25
3 说明	1	9 Application and Implementation	27
4 Revision History	2	9.1 Application Information.....	27
5 Pin Configuration and Functions	3	9.2 Typical Application.....	27
6 Specifications	4	10 Power Supply Recommendations	28
6.1 Absolute Maximum Ratings	4	11 Layout	29
6.2 ESD Ratings	4	11.1 Layout Guidelines.....	29
6.3 ESD Ratings - IEC	4	11.2 Layout Example.....	30
6.4 Thermal Information	4	12 Device and Documentation Support	31
6.5 Recommended Operating Conditions	5	12.1 Documentation Support.....	31
6.6 Electrical Characteristics	5	12.2 Receiving Notification of Documentation Updates..	31
6.7 Switching Characteristics	8	12.3 支持资源.....	31
6.8 Timing Requirements	9	12.4 Trademarks.....	31
6.9 Typical Characteristics.....	10	12.5 Electrostatic Discharge Caution.....	32
7 Parameter Measurement Information	12	12.6 术语表.....	32
8 Detailed Description	21	13 Mechanical, Packaging, and Orderable Information	32
8.1 Overview.....	21		
8.2 Functional Block Diagram.....	21		

4 Revision History

注：以前版本的页码可能与当前版本的页码不同

Changes from Revision A (October 2020) to Revision B (May 2022)	Page
• 将提到的所有旧术语实例更改为“指挥官”和“响应者”。.....	1

Changes from Revision * (July 2020) to Revision A (October 2020)	Page
• Changed R_{EN} typical from 350 k Ω to 205 k Ω	5

5 Pin Configuration and Functions



图 5-1. D Package, 8-Pin (SOIC)
(Top View)



图 5-2. DRB Package, 8-Pin (VSON)
Top View

表 5-1. Pin Functions

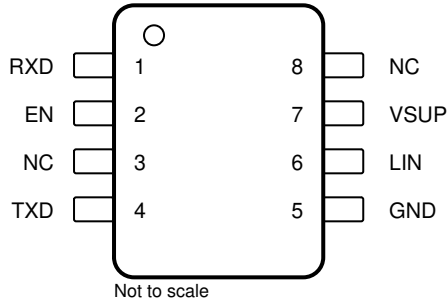
PIN		Type	DESCRIPTION
Name	No.		
RXD	1	DO	RXD output (open-drain) interface reporting state of LIN bus voltage
EN	2	DI	Enable input - High puts the device in normal operation mode and low puts the device in sleep mode
NC	3	-	Not connected
TXD	4	DI	TXD input interface to control state of LIN output - Internally pulled to ground
GND	5	GND	Ground
LIN	6	HV I/O	LIN bus single-wire transmitter and receiver
V _{SUP}	7	HV Supply	Device supply voltage (connected to battery in series with external reverse blocking diode)
NC	8	-	Not connected
Thermal Pad		-	No electrical connection. Can be connected to the PCB to improve thermal coupling (DRB package only)

6 Specifications

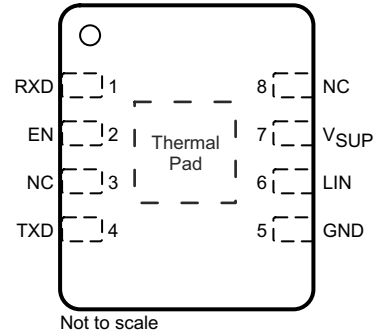
6.1 Absolute Maximum Ratings

parameters valid across $-40^{\circ}\text{C} \leq T_A \leq 125^{\circ}\text{C}$ (unless otherwise noted)⁽¹⁾

Symbol	Parameter	MIN	MAX	UNIT
V _{SUP}	Supply voltage range (ISO/DIS 17987 Param 10)	- 0.3	45	V
V _{LIN}	LIN bus input voltage (ISO/DIS 17987 Param 82)	- 45	45	V
V _{LOGIC}	Logic pin voltage (RXD, TXD, EN)	- 0.3	6	V
T _A	Ambient temperature range	- 40	125	°C
T _J	Junction temperature range	- 55	150	°C

- (1) Stresses beyond those listed under Absolute Maximum Ratings may cause permanent damage to the device. These are stress ratings only, which do not imply functional operation of the device at these or any other conditions beyond those indicated under Recommended Operating Conditions. Exposure to absolute-maximum-rated conditions for extended periods may affect device reliability.

6.2 ESD Ratings

ESD Ratings				VALUE	UNIT
V _(ESD)	Electrostatic discharge	Human body model (HBM) TXD, RXD, EN Pins, per AEC Q100-002 ⁽¹⁾		±4000	V
		Human body model (HBM) LIN and V _{SUP} Pin, per AEC Q100-002 ⁽²⁾		±8000	
		Charged device model (CDM), per AEC Q100-011	All terminals	±1500	

- (1) JEDEC document JEP155 states that 500-V HBM allows safe manufacturing with a standard ESD control process.
 (2) LIN bus is stressed with respect to GND.

6.3 ESD Ratings - IEC

ESD and Surge Protection Ratings			VALUE	UNIT
V _(ESD)	Electrostatic discharge	ISO 10605 per IEC 62228-3 Contact discharge	±8000	V
V _(ESD)	Powered ESD Performance, per SAEJ2962-1 ⁽¹⁾	contact discharge	±8000	V
		air-gap discharge	±25000	
ISO 7637-2 and IEC 62215-3 transients according to IBEE LIN EMC test specifications ⁽²⁾ (LIN and V _{SUP})		Pulse 1	- 100	V
		Pulse 2	75	V
		Pulse 3a	- 150	V
		Pulse 3b	100	V

- (1) SAEJ2962-1 Testing performed at 3rd party EMC test facility, test report available upon request.
 (2) ISO 7637 is a system level transient test. Different system level configurations may lead to different results.

6.4 Thermal Information

THERMAL METRIC ⁽¹⁾		TLIN1027D	TLIN1027DRB	UNIT
		D (SOIC)	DRB (VSON)	
		8-PINS	8-PINS	
R _{θJA}	Junction-to-ambient thermal resistance	115.5	48.5	°C/W
R _{θJC(top)}	Junction-to-case (top) thermal resistance	58.7	55.5	°C/W
R _{θJB}	Junction-to-board thermal resistance	58.9	22.2	°C/W
Ψ _{JT}	Junction-to-top characterization parameter	14.1	1.2	°C/W
Ψ _{JB}	Junction-to-board characterization parameter	58.2	22.2	°C/W

6.4 Thermal Information (continued)

THERMAL METRIC ⁽¹⁾		TLIN1027D	TLIN1027DRB	UNIT
		D (SOIC)	DRB (VSON)	
		8-PINS	8-PINS	
R _{θJC(bot)}	Junction-to-case (bottom) thermal resistance	-	4.8	°C/W

(1) For more information about traditional and new thermal metrics, see the Semiconductor and IC Package Thermal Metrics application report, SPRA953.

6.5 Recommended Operating Conditions

parameters valid across $-40^{\circ}\text{C} \leq T_A \leq 125^{\circ}\text{C}$ (unless otherwise noted)

PARAMETER - DEFINITION		MIN	NOM	MAX	UNIT
V _{SUP}	Supply voltage	4		36	V
V _{LIN}	LIN Bus input voltage	0		36	V
V _{LOGIC}	Logic Pin Voltage (RXD, TXD, EN)	0		5.25	V
TSD	Thermal shutdown temperature	165			°C
TSD _(HYS)	Thermal shutdown hysteresis		15		°C

6.6 Electrical Characteristics

parameters valid across $-40^{\circ}\text{C} \leq T_A \leq 125^{\circ}\text{C}$ (unless otherwise noted)

PARAMETER		TEST CONDITIONS	MIN	TYP	MAX	UNIT
Power Supply						
V _{SUP}	Operational supply voltage (ISO/DIS 17987 Param 10)	Device is operational beyond the LIN defined nominal supply voltage range. See 图 7-1 and 图 7-2	4		36	V
V _{SUP}	Nominal supply voltage (ISO/DIS 17987 Param 10)	Normal and Standby Modes: ramp V _{SUP} while LIN signal is a 10 kHz square wave with 50 % duty cycle and 18V swing. See 图 7-1 and 图 7-2	4		36	V
		Sleep Mode	4		36	V
UV _{SUP}	Under voltage V _{SUP} threshold	Min is falling edge and Max is rising edge	2.9		3.85	V
UV _{HYS}	Delta hysteresis voltage for V _{SUP} under voltage threshold			0.2		V
I _{SUP}	Supply current	Normal Mode: EN = high, bus dominant: total bus load where R _{LIN} > 500 Ω and C _{LIN} < 10 nF (See 图 7-7)			5	mA
		Standby Mode: EN = low, bus dominant: total bus load where R _{LIN} > 500 Ω and C _{LIN} < 10 nF (See 图 7-7)		1	2.1	mA
I _{SUP}	Supply current	Normal Mode: EN = high, bus recessive (LIN = V _{SUP})		300	650	μA
		Standby Mode: EN = low, bus recessive (LIN = V _{SUP})		10	30	μA
		Sleep Mode: 4.0 V < V _{SUP} ≤ 14 V, LIN = V _{SUP} , EN = 0 V, TXD and RXD floating		8	12	μA
		Sleep Mode: 14 V < V _{SUP} ≤ 36 V, LIN = V _{SUP} , EN = 0 V, TXD and RXD floating			20	μA
TSD	Thermal shutdown		165			°C
TSD _(HYS)	Thermal shutdown hysteresis			15		°C
RXD OUTPUT PIN (OPEN DRAIN)						
V _{OL}	Output low voltage	R _{PU} = 2.4 kΩ			0.6	V

6.6 Electrical Characteristics (continued)

parameters valid across $-40^{\circ}\text{C} \leq T_A \leq 125^{\circ}\text{C}$ (unless otherwise noted)

PARAMETER		TEST CONDITIONS	MIN	TYP	MAX	UNIT
I_{OL}	Low level output current, open drain	LIN = 0 V, RXD = 0.4 V	1.5			mA
I_{ILG}	Leakage current, high-level	LIN = V_{SUP} , RXD = 5 V	-5	0	5	μA
TXD INPUT PIN						
V_{IL}	Low level input voltage		-0.3		0.8	V
V_{IH}	High level input voltage		2		5.5	V
I_{ILG}	Low level input leakage current	TXD = low	-5	0	5	μA
R_{TXD}	Internal pull-down resistor value		125	350	800	$\text{k}\Omega$
LIN PIN						
V_{OH}	HIGH level output voltage	LIN recessive, TXD = high, $I_O = 0$ mA, $V_{SUP} = 7$ V to 36 V ⁽¹⁾	0.85			V_{SUP}
		LIN recessive, TXD = high, $I_O = 0$ mA, $V_{SUP} = 4$ V $\leq V_{SUP} < 7$ V ⁽¹⁾	3			V
V_{OL}	LOW level output voltage	LIN dominant, TXD = low, $V_{SUP} = 7$ V to 36 V ⁽¹⁾			0.2	V_{SUP}
		LIN dominant, TXD = low, $V_{SUP} = 4$ V $\leq V_{SUP} < 7$ V ⁽¹⁾			1.2	V
$V_{SUP_NON_OP}$	V_{SUP} where impact of recessive LIN bus < 5% (ISO/DIS 17987 Param 11)	TXD & RXD open LIN = 4 V to 45 V	-0.3		45	V
I_{BUS_LIM}	Limiting current (ISO/DIS 17987 Param 12)	TXD = 0 V, $V_{LIN} = 18$ V, $R_{MEAS} = 440 \Omega$, $V_{SUP} = 18$ V, $V_{BUSdom} < 4.518$ V See 图 7-6	40	90	200	mA
$I_{BUS_PAS_dom}$	Receiver leakage current, dominant (ISO/DIS 17987 Param 13)	LIN = 0 V, $V_{SUP} = 12$ V Driver off/recessive 图 7-7	-1			mA
$I_{BUS_PAS_rec1}$	Receiver leakage current, recessive (ISO/DIS 17987 Param 14)	LIN > V_{SUP} , 4 V $\leq V_{SUP} \leq 36$ V Driver off; 图 7-8			20	μA
$I_{BUS_PAS_rec2}$	Receiver leakage current, recessive (ISO/DIS 17987 Param 14)	LIN = V_{SUP} , Driver off; 图 7-8	-5		5	μA
$I_{BUS_NO_GND}$	Leakage current, loss of ground (ISO/DIS 17987 Param 15)	GND = V_{SUP} , $V_{SUP} = 18$ V, LIN = 0 V; 图 7-9	-1		1	mA
$I_{BUS_NO_BAT}$	Leakage current, loss of supply (ISO/DIS 17987 Param 16)	LIN = 18 V, $V_{SUP} = \text{GND}$; 图 7-10			5	μA
V_{BUSdom}	Low level input voltage (ISO/DIS 17987 Param 17)	LIN dominant (including LIN dominant for wake up) See 图 7-4 , 图 7-3			0.4	V_{SUP}
V_{BUSrec}	High level input voltage (ISO/DIS 17987 Param 18)	LIN recessive See 图 7-4 , 图 7-3	0.6			V_{SUP}
V_{BUS_CNT}	Receiver center threshold (ISO/DIS 17987 Param 19)	$V_{BUS_CNT} = (V_{IL} + V_{IH})/2$ See 图 7-4 , 图 7-3	0.475	0.5	0.525	V_{SUP}
V_{HYS}	Hysteresis voltage (ISO/DIS 17987 Param 20)	$V_{HYS} = (V_{IL} - V_{IH})$ See 图 7-4 , 图 7-3			0.175	V_{SUP}
V_{SERIAL_DIODE}	Serial diode LIN term pull-up path	By design and characterization	0.4	0.7	1	V
R_{PU_LIN}	Internal pull-up resistor to V_{SUP}	Normal and standby modes	20	45	60	$\text{k}\Omega$
I_{RSLEEP}	Pull-up current source to V_{SUP}	Sleep mode, $V_{SUP} = 14$ V, LIN = GND	-2		-20	μA
C_{LINPIN}	Capacitance of the LIN pin	$V_{SUP} = 14$ V			25	pF
EN INPUT PIN						
V_{IL}	Low level input voltage		-0.3		0.8	V
V_{IH}	High level input voltage		2		5.5	V
V_{IT}	Hysteresis voltage	By design and characterization		50	500	mV
I_{ILG}	Low level input current	EN = low	-5	0	5	μA

6.6 Electrical Characteristics (continued)

parameters valid across $-40^{\circ}\text{C} \leq T_A \leq 125^{\circ}\text{C}$ (unless otherwise noted)

PARAMETER		TEST CONDITIONS	MIN	TYP	MAX	UNIT
R _{EN}	Internal pull-down resistor		125	205	800	k Ω

(1) LIN driver bus load conditions (C_{LIN}, R_{LIN}): No external load

6.7 Switching Characteristics

parameters valid across $-40^{\circ}\text{C} \leq T_A \leq 125^{\circ}\text{C}$ (unless otherwise noted)

PARAMETER		TEST CONDITIONS	MIN	TYP	MAX	UNIT
D1 _{12V}	Duty Cycle 1 (ISO/DIS 17987 Param 27) ⁽¹⁾	$T_{H_{REC}(MAX)} = 0.744 \times V_{SUP}$, $T_{H_{DOM}(MAX)} = 0.581 \times V_{SUP}$, $V_{SUP} = 4\text{ V to }7.4\text{ V}$, $t_{BIT} = 50\ \mu\text{s}$ (20 kbps), $D1 = t_{BUS_rec(min)}/(2 \times t_{BIT})$ (See Fig 7-11 , Fig 7-12)	0.396			
D1 _{12V}	Duty Cycle 1	$T_{H_{REC}(MAX)} = 0.625 \times V_{SUP}$, $T_{H_{DOM}(MAX)} = 0.581 \times V_{SUP}$, $V_{SUP} = 7.4\text{ V to }9.4\text{ V}$, $t_{BIT} = 50\ \mu\text{s}$ (20 kbps), $D1 = t_{BUS_rec(min)}/(2 \times t_{BIT})$ (See Fig 7-11 , Fig 7-12)	0.368			
D1 _{12V}	Duty Cycle 1 (ISO/DIS 17987 Param 27)	$T_{H_{REC}(MAX)} = 0.744 \times V_{SUP}$, $T_{H_{DOM}(MAX)} = 0.581 \times V_{SUP}$, $V_{SUP} = 9.4\text{ V to }18\text{ V}$, $t_{BIT} = 50\ \mu\text{s}$ (20 kbps), $D1 = t_{BUS_rec(min)}/(2 \times t_{BIT})$ (See Fig 7-11 , Fig 7-12)	0.396			
D2 _{12V}	Duty Cycle 2 (ISO/DIS 17987 Param 28)	$T_{H_{REC}(MIN)} = 0.422 \times V_{SUP}$, $T_{H_{DOM}(MIN)} = 0.284 \times V_{SUP}$, $V_{SUP} = 4\text{ V to }7.4\text{ V}$, $t_{BIT} = 50\ \mu\text{s}$ (20 kbps), $D2 = t_{BUS_rec(MAX)}/(2 \times t_{BIT})$ (See Fig 7-11 , Fig 7-12)			0.581	
D2 _{12V}	Duty Cycle 2	$T_{H_{REC}(MIN)} = 0.422 \times V_{SUP}$, $T_{H_{DOM}(MIN)} = 0.284 \times V_{SUP}$, $V_{SUP} = 7.4\text{ V to }9.4\text{ V}$, $t_{BIT} = 50\ \mu\text{s}$ (20 kbps), $D2 = t_{BUS_rec(MAX)}/(2 \times t_{BIT})$ (See Fig 7-11 , Fig 7-12)			0.67	
D2 _{12V}	Duty Cycle 2 (ISO/DIS 17987 Param 28)	$T_{H_{REC}(MIN)} = 0.422 \times V_{SUP}$, $T_{H_{DOM}(MIN)} = 0.284 \times V_{SUP}$, $V_{SUP} = 9.4\text{ V to }18\text{ V}$, $t_{BIT} = 50\ \mu\text{s}$ (20 kbps), $D2 = t_{BUS_rec(MAX)}/(2 \times t_{BIT})$ (See Fig 7-11 , Fig 7-12)			0.581	
D3 _{12V}	Duty Cycle 3 (ISO/DIS 17987 Param 29)	$T_{H_{REC}(MAX)} = 0.778 \times V_{SUP}$, $T_{H_{DOM}(MAX)} = 0.616 \times V_{SUP}$, $V_{SUP} = 7\text{ V to }18\text{ V}$, $t_{BIT} = 96\ \mu\text{s}$ (10.4 kbps), $D3 = t_{BUS_rec(min)}/(2 \times t_{BIT})$ (See Fig 7-11 , Fig 7-12)	0.417			
D3 _{12V}	Duty Cycle 3	$T_{H_{REC}(MAX)} = 0.645 \times V_{SUP}$, $T_{H_{DOM}(MAX)} = 0.616 \times V_{SUP}$, $V_{SUP} = 4\text{ V to }7\text{ V}$, $t_{BIT} = 96\ \mu\text{s}$ (10.4 kbps), $D3 = t_{BUS_rec(min)}/(2 \times t_{BIT})$ (See Fig 7-11 , Fig 7-12)	0.417			
D4 _{12V}	Duty Cycle 4 (ISO/DIS 17987 Param 30)	$T_{H_{REC}(MIN)} = 0.389 \times V_{SUP}$, $T_{H_{DOM}(MIN)} = 0.251 \times V_{SUP}$, $V_{SUP} = 4.6\text{ V to }7.4\text{ V}$, $t_{BIT} = 96\ \mu\text{s}$ (10.4 kbps), $D4 = t_{BUS_rec(MAX)}/(2 \times t_{BIT})$ (See Fig 7-11 , Fig 7-12)			0.59	
D4 _{12V}	Duty Cycle 4	$T_{H_{REC}(MIN)} = 0.389 \times V_{SUP}$, $T_{H_{DOM}(MIN)} = 0.251 \times V_{SUP}$, $V_{SUP} = 7.4\text{ V to }9.4\text{ V}$, $t_{BIT} = 96\ \mu\text{s}$ (10.4 kbps), $D4 = t_{BUS_rec(MAX)}/(2 \times t_{BIT})$ (See Fig 7-11 , Fig 7-12)			0.6	
D4 _{12V}	Duty Cycle 4 (ISO/DIS 17987 Param 30)	$T_{H_{REC}(MIN)} = 0.389 \times V_{SUP}$, $T_{H_{DOM}(MIN)} = 0.251 \times V_{SUP}$, $V_{SUP} = 7.4\text{ V to }18\text{ V}$, $t_{BIT} = 96\ \mu\text{s}$ (10.4 kbps), $D4 = t_{BUS_rec(MAX)}/(2 \times t_{BIT})$ (See Fig 7-11 , Fig 7-12)			0.59	

- (1) Duty cycles: LIN driver bus load conditions (C_{LIN} , R_{LIN}): Load1 = 1 nF, 1 k Ω ; Load2 = 10 nF, 500 Ω , Load3 = 6.8 nF, 660 Ω . Duty cycles 3 and 4 are defined for 10.4-kbps operation. The TLIN1027 also meets these lower data rate requirements, while it is capable of the higher speed 20-kbps operation as specified by duty cycles 1 and 2. SAEJ2602 derives propagation delay equations from the LIN 2.0 duty cycle definitions, for details see the SAEJ2602 specification

6.8 Timing Requirements

SYMBOL	DESCRIPTION	TEST CONDITIONS	MIN	NOM	MAX	UNIT
t_{rx_pdr}, t_{rx_pdf}	Receiver rising and falling propagation delay time (ISO/DIS 17987 Param 31)	$R_{RXD} = 2.4\text{ k}\Omega$, $C_{RXD} = 20\text{ pF}$ (See 图 7-13 and 图 7-14)			6	μs
t_{rx_sym}	Symmetry of receiver propagation delay time	Rising edge with respect to falling edge, ($tr_{x_sym} = t_{rx_pdf} - t_{rx_pdr}$), $R_{RXD} = 2.4\text{ k}\Omega$, $C_{RXD} = 20\text{ pF}$ (See 图 7-13 and 图 7-14)	- 2		2	μs
t_{LINBUS}	LIN wakeup time (Minimum dominant time on LIN bus for wakeup)	See 图 7-17 , 图 8-2 , and 图 8-3	25	65	150	μs
t_{CLEAR}	Time to clear false wakeup prevention logic if LIN bus had a bus stuck dominant fault (recessive time on LIN bus to clear bus stuck dominant fault)	See 图 8-3	8	25	50	μs
t_{MODE_CHANGE}	Mode change delay time	Time to change from standby mode to normal mode or normal mode to sleep mode through EN pin (See 图 7-15 and 图 8-4)	2		15	μs
t_{NOMINT}	Normal mode initialization time	Time for normal mode to initialize and data on RXD pin to be valid (See 图 7-15)			35	μs
t_{PWR}	Power up time	Upon power up time it takes for valid data on RXD			1.5	ms

6.9 Typical Characteristics



图 6-1. V_{OH} vs V_{SUP} and Temperature

D001

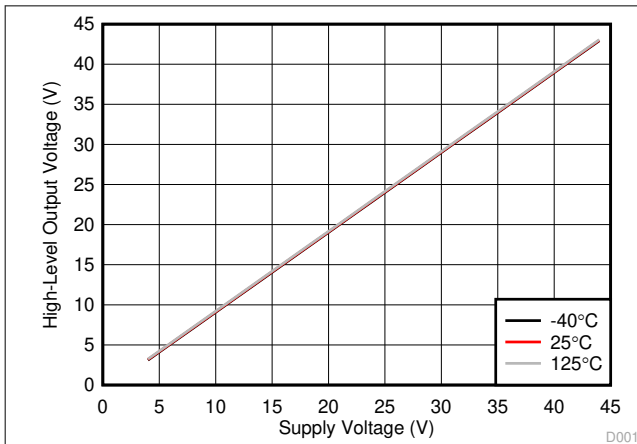

图 6-2. V_{OL} vs V_{SUP} and Temperature

D002

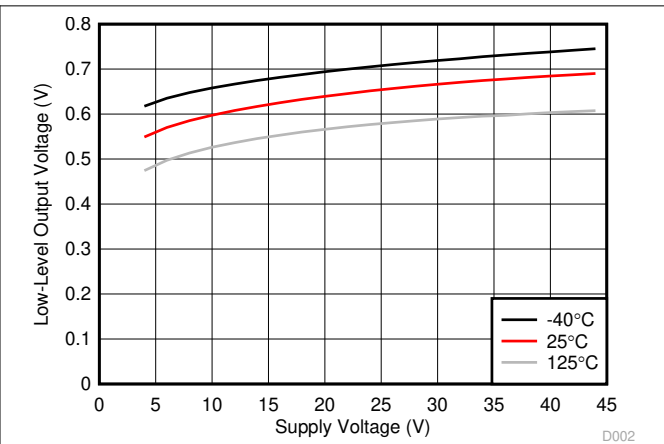

图 6-3. Dominant I_{SUP} vs V_{SUP} and Temperature

D003

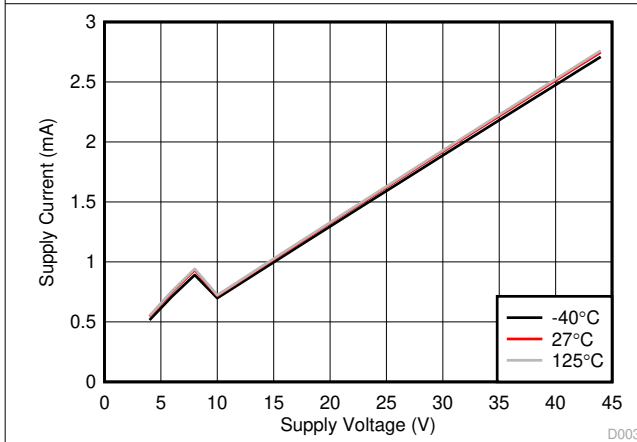

图 6-4. Recessive I_{SUP} vs V_{SUP} and Temperature

D004

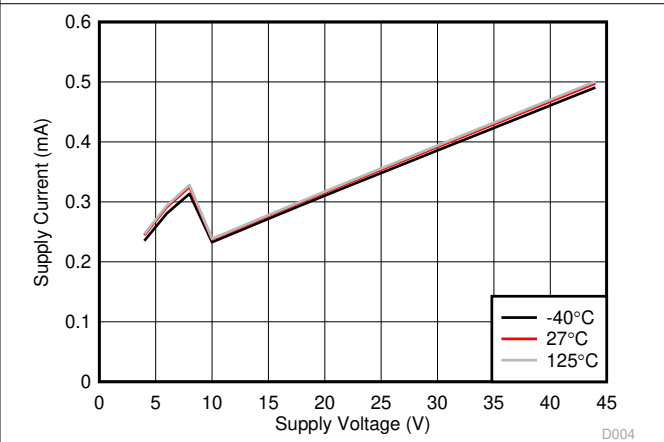

图 6-5. Standby Dominant I_{SUP} vs V_{SUP} and Temperature

D005

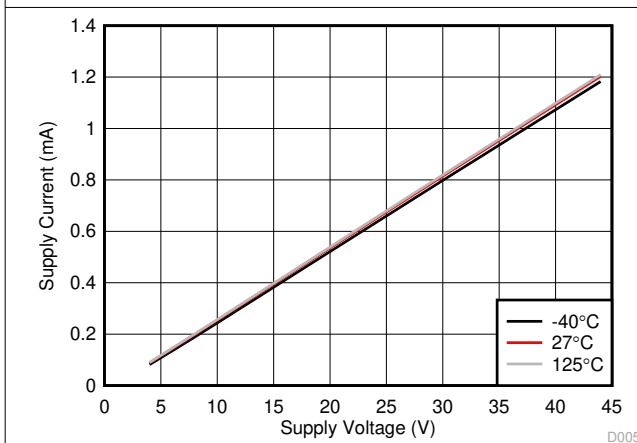

图 6-6. Standby Recessive I_{SUP} vs V_{SUP} and Temperature

D006

6.9 Typical Characteristics (continued)

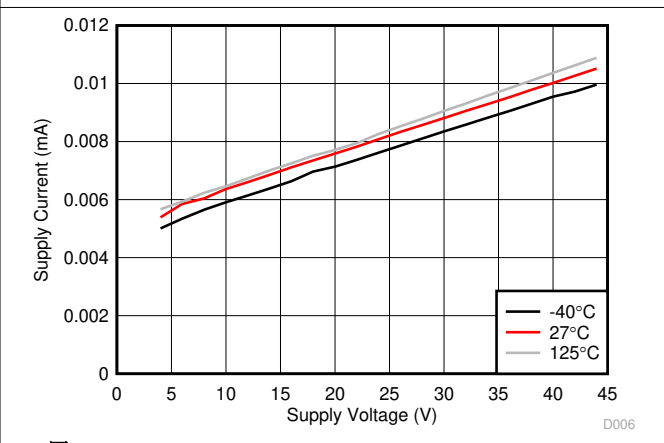

图 6-7. Sleep Current vs V_{SUP} and Temperature

7 Parameter Measurement Information



图 7-1. Test System: Operating Voltage Range with RX and TX Access: Parameters 9, 10

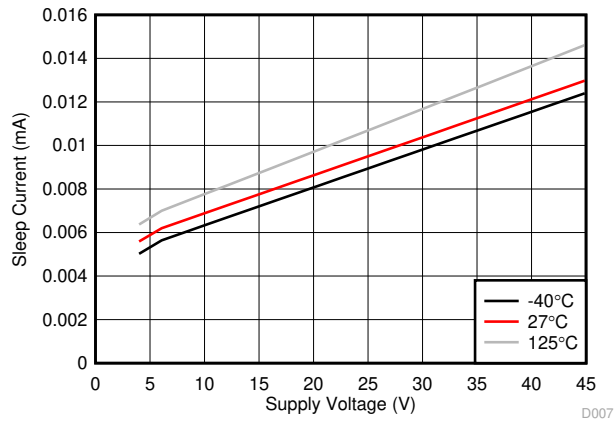

图 7-2. RX Response: Operating Voltage Range

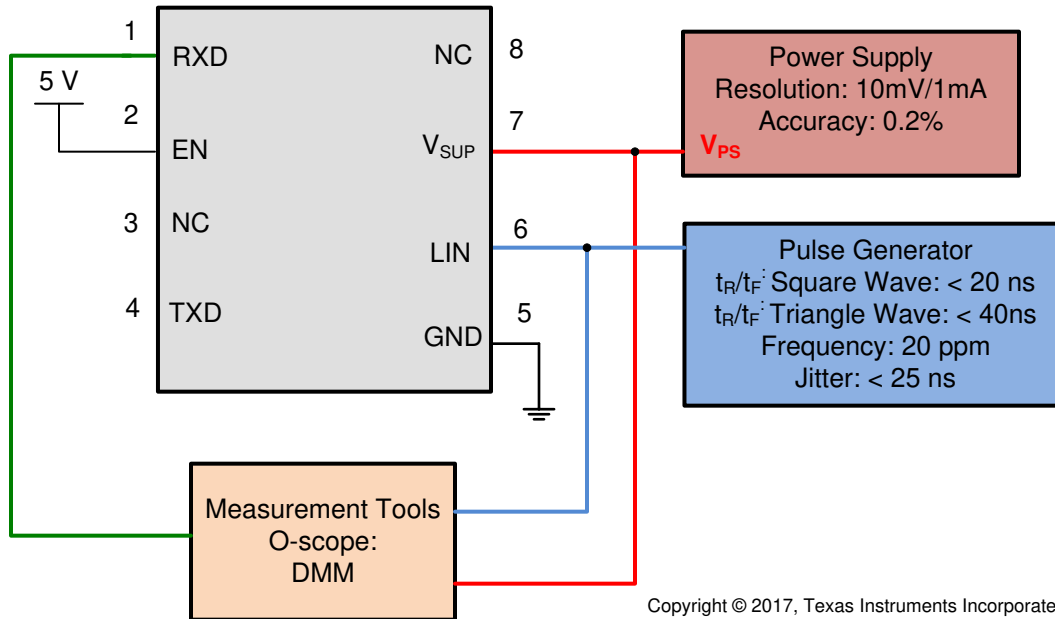

图 7-3. LIN Bus Input Signal

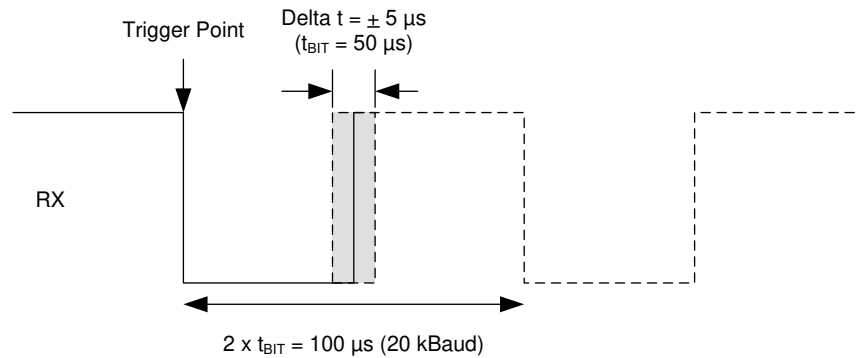

图 7-4. LIN Receiver Test with RX access Param 17, 18, 19, 20

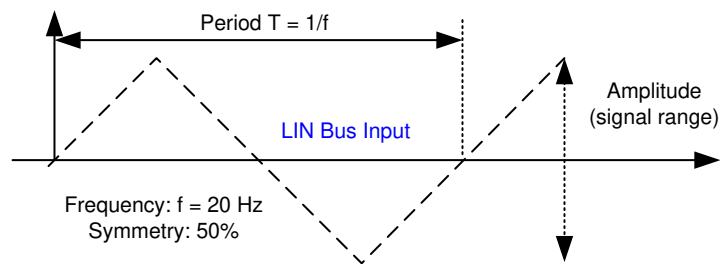

图 7-5. $V_{SUP_NON_OP}$ Param 11

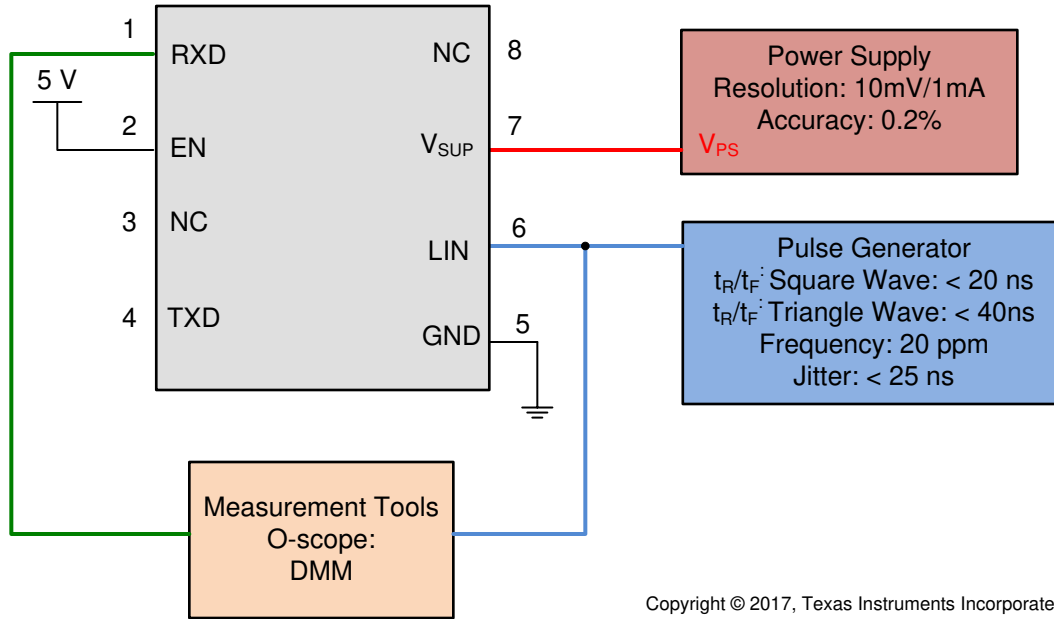

Copyright © 2017, Texas Instruments Incorporated

图 7-6. Test Circuit for I_{BUS_LIM} at Dominant State (Driver on) Param 12

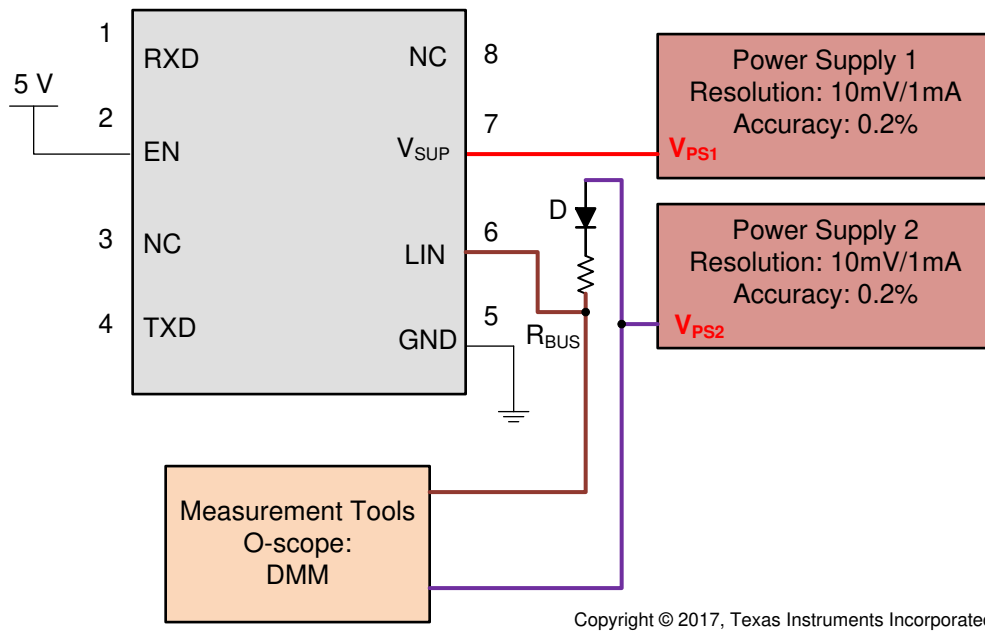
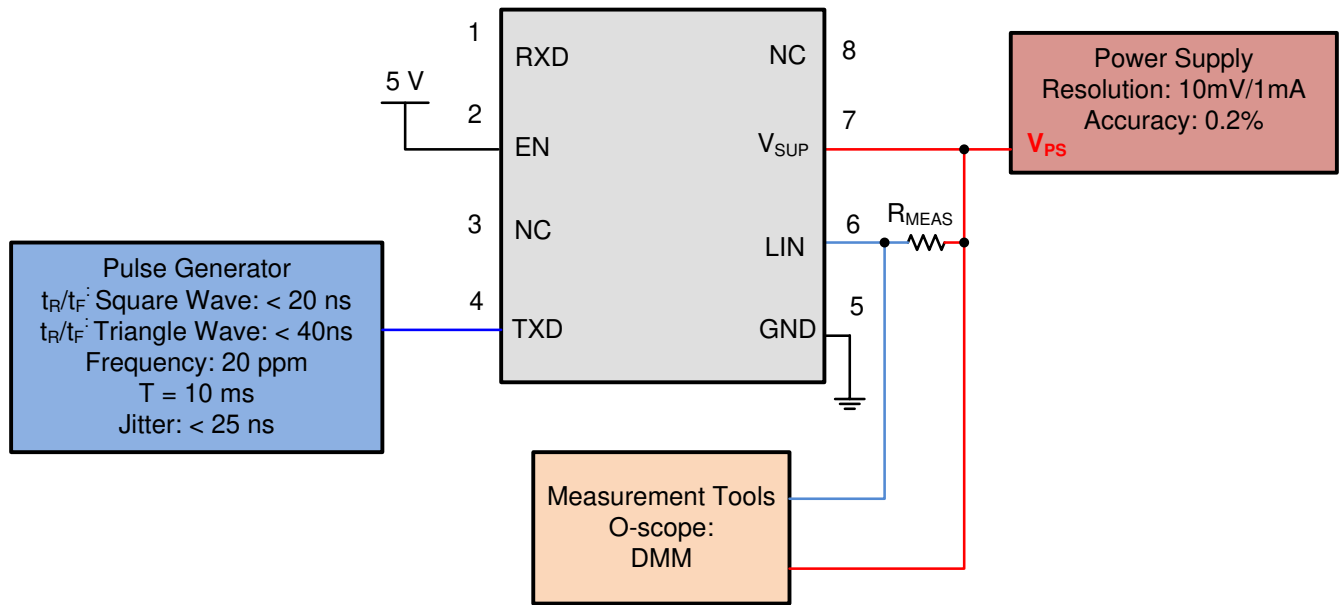
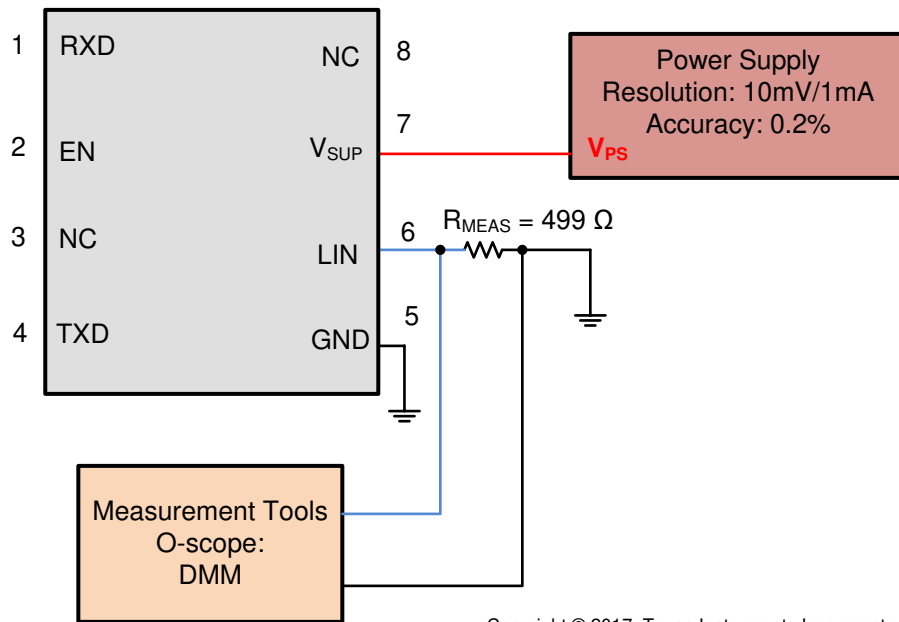

Copyright © 2017, Texas Instruments Incorporated

图 7-7. Test Circuit for $I_{BUS_PAS_dom}$; TXD = Recessive State $V_{BUS} = 0 V$, Param 13



图 7-8. Test Circuit for $I_{BUS_PAS_rec}$ Param 14



图 7-9. Test Circuit for $I_{BUS_NO_GND}$ Loss of GND

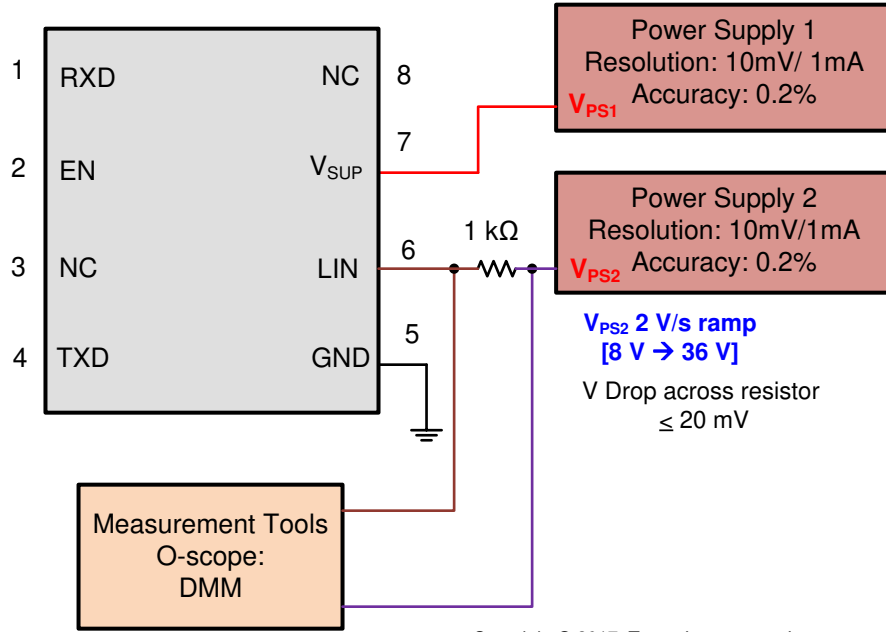

图 7-10. Test Circuit for $I_{BUS_NO_BAT}$ Loss of Battery

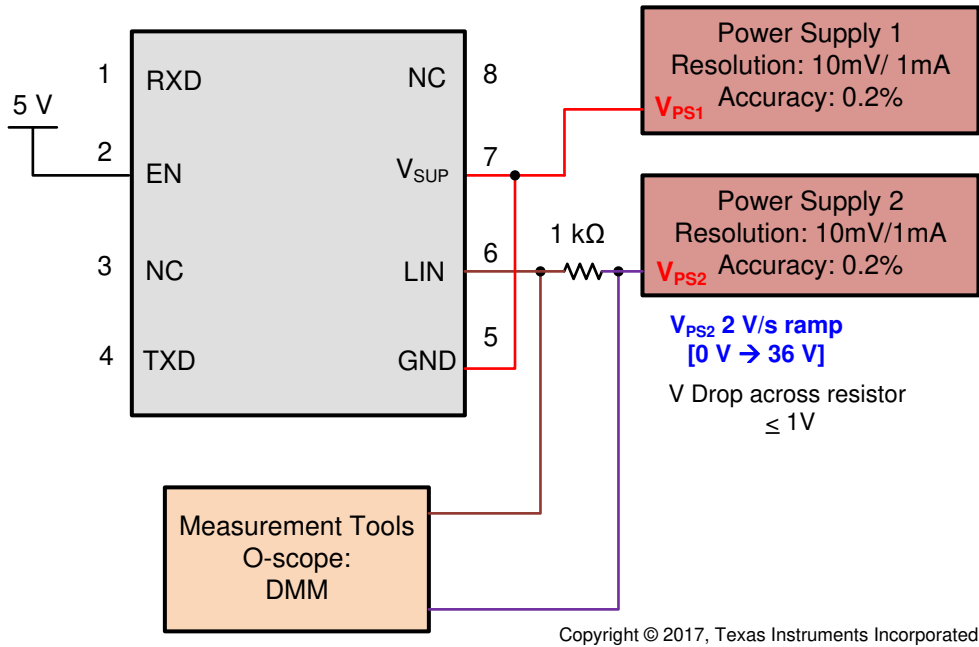

图 7-11. Test Circuit Slope Control and Duty Cycle Param 27, 28, 29, 30

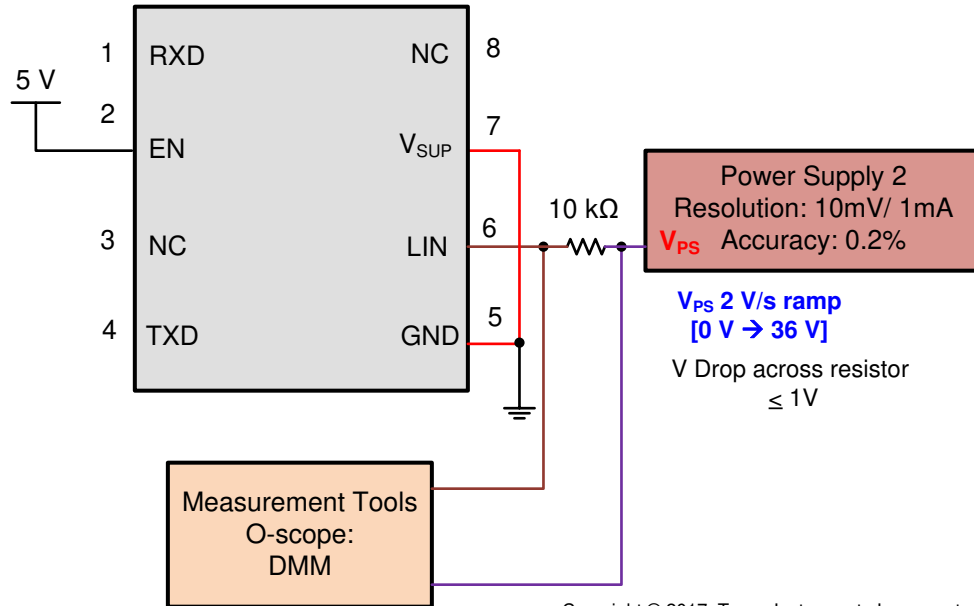

图 7-12. Definition of Bus Timing Parameters

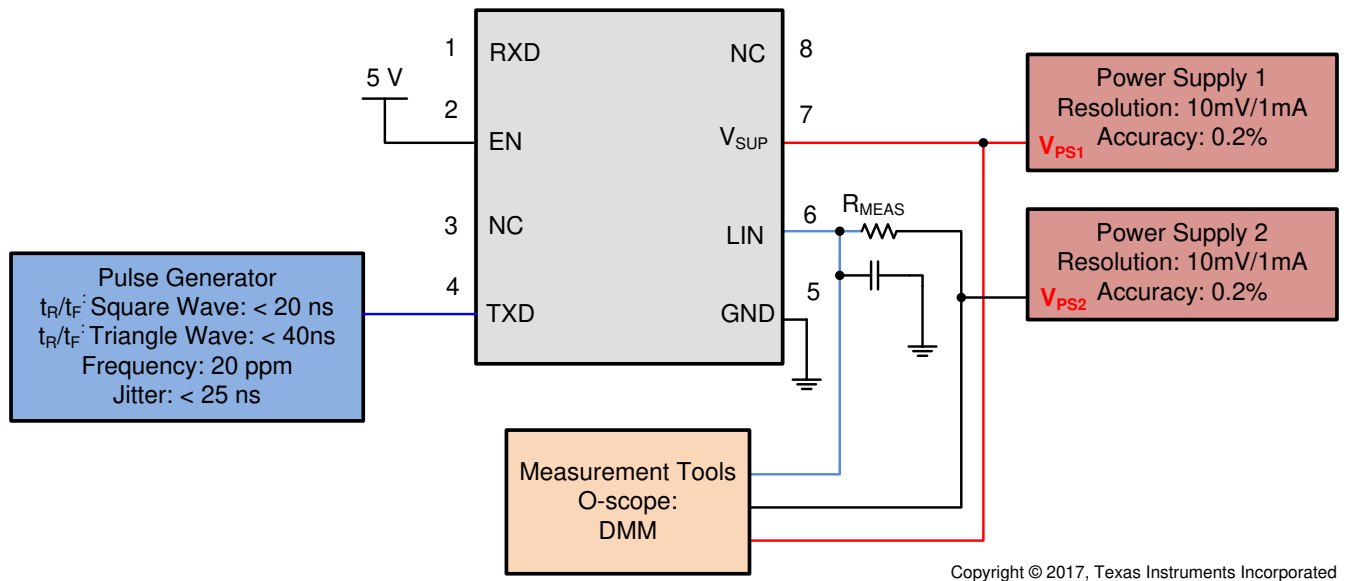

图 7-13. Propagation Delay Test Circuit; Param 31, 32

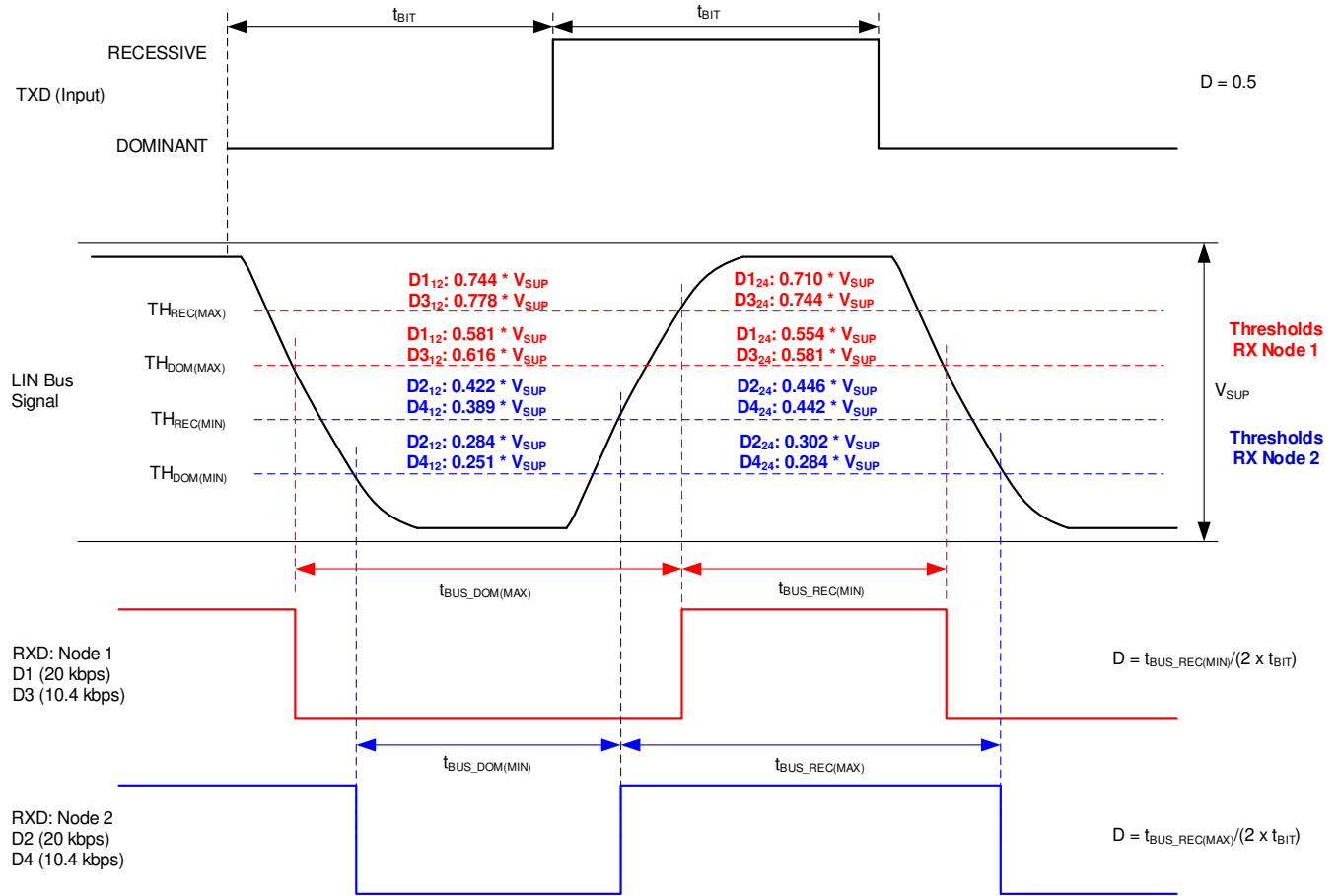

Copyright © 2017, Texas Instruments Incorporated

图 7-14. Propagation Delay

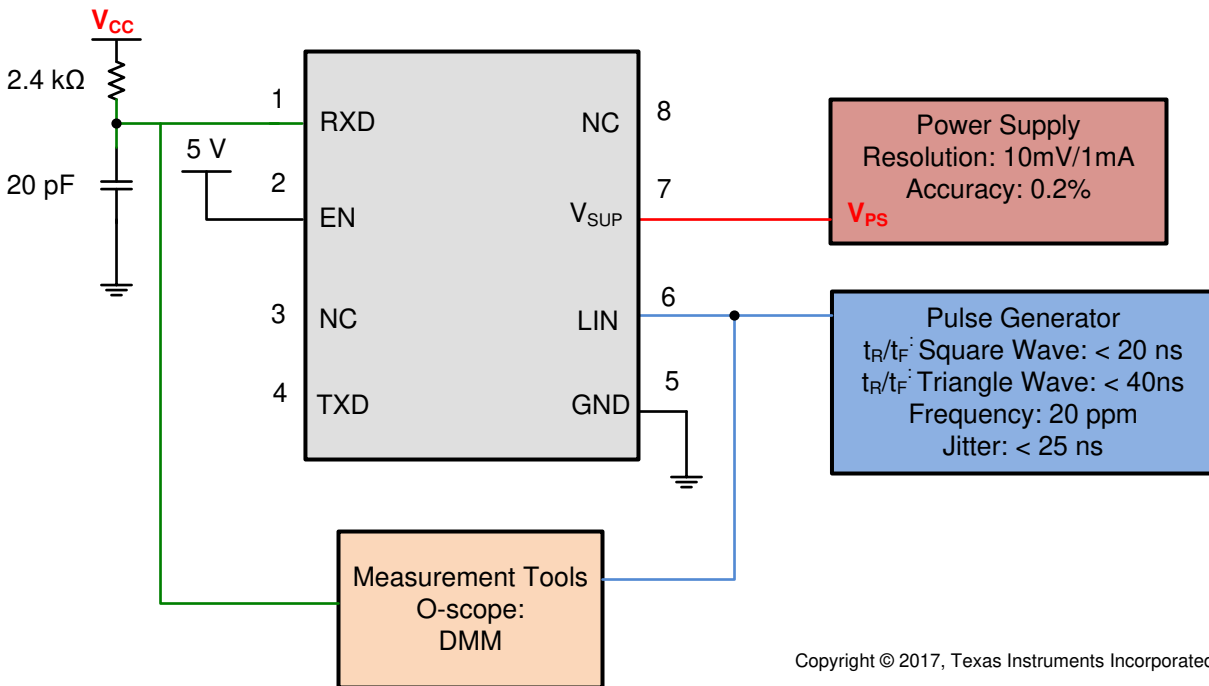
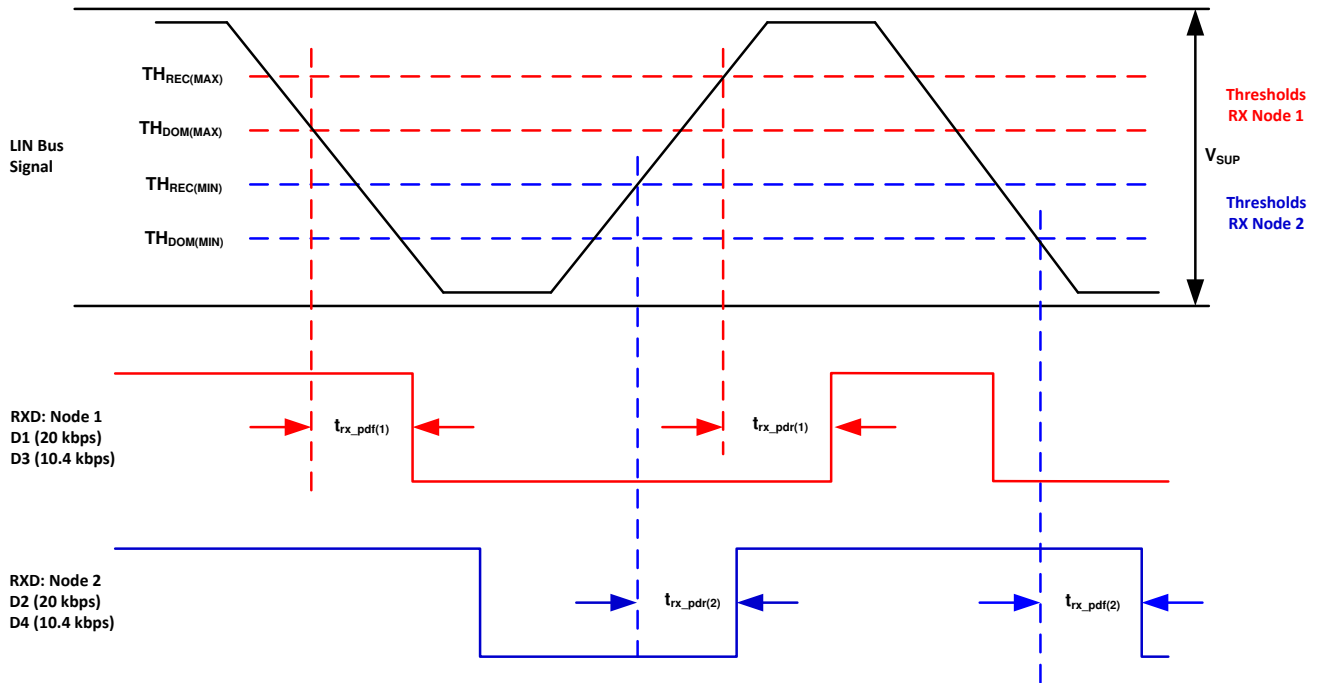

图 7-15. Mode Transitions



图 7-16. Wake-up Through EN

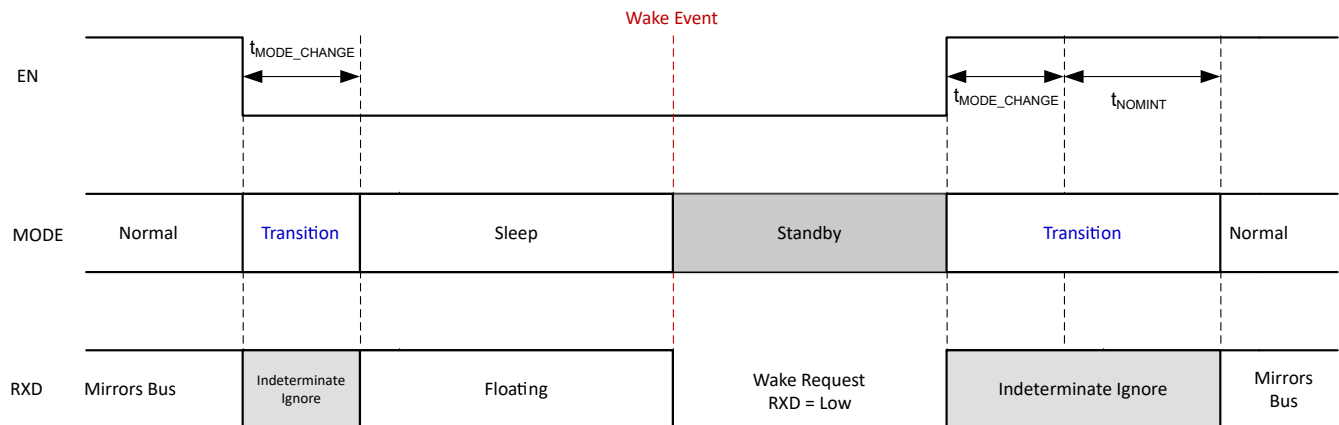

图 7-17. Wake-up through LIN

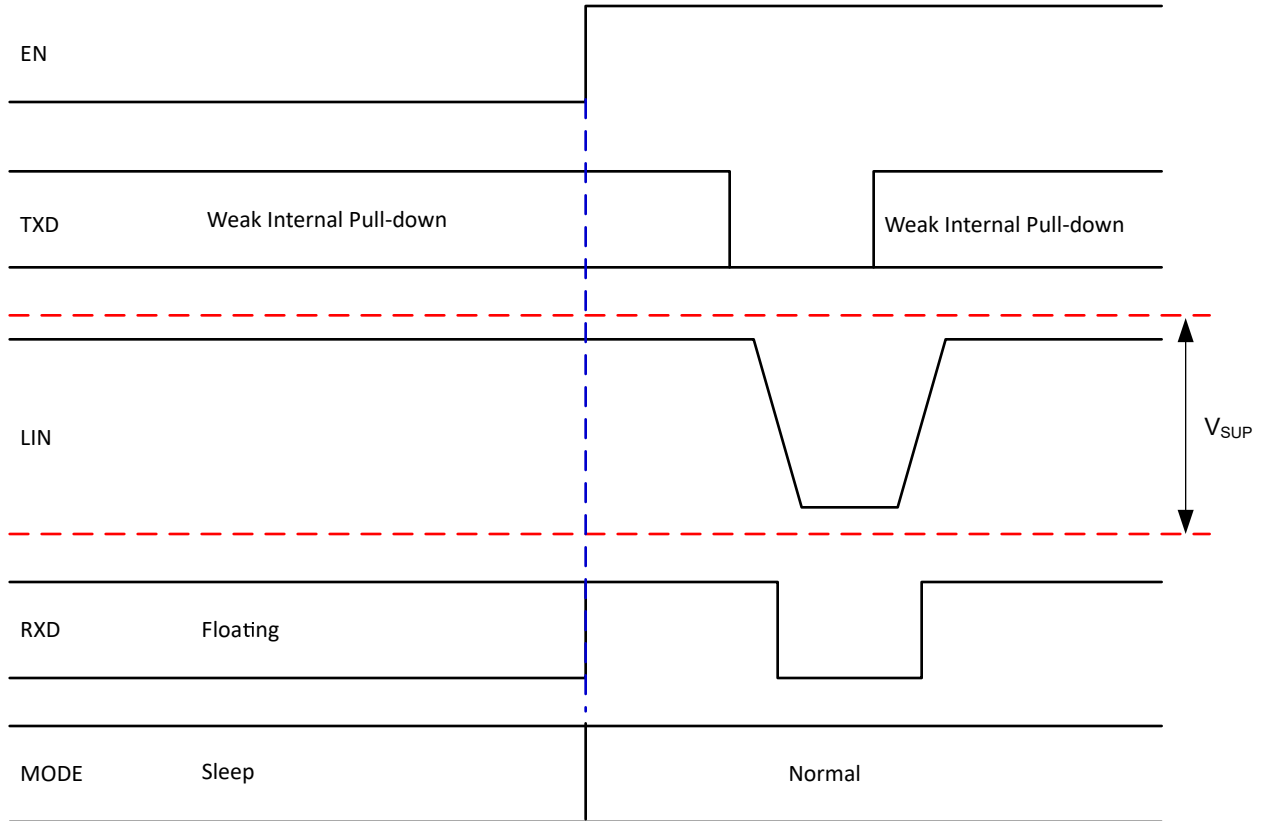

Copyright © 2017, Texas Instruments Incorporated

图 7-18. Test Circuit for AC Characteristics

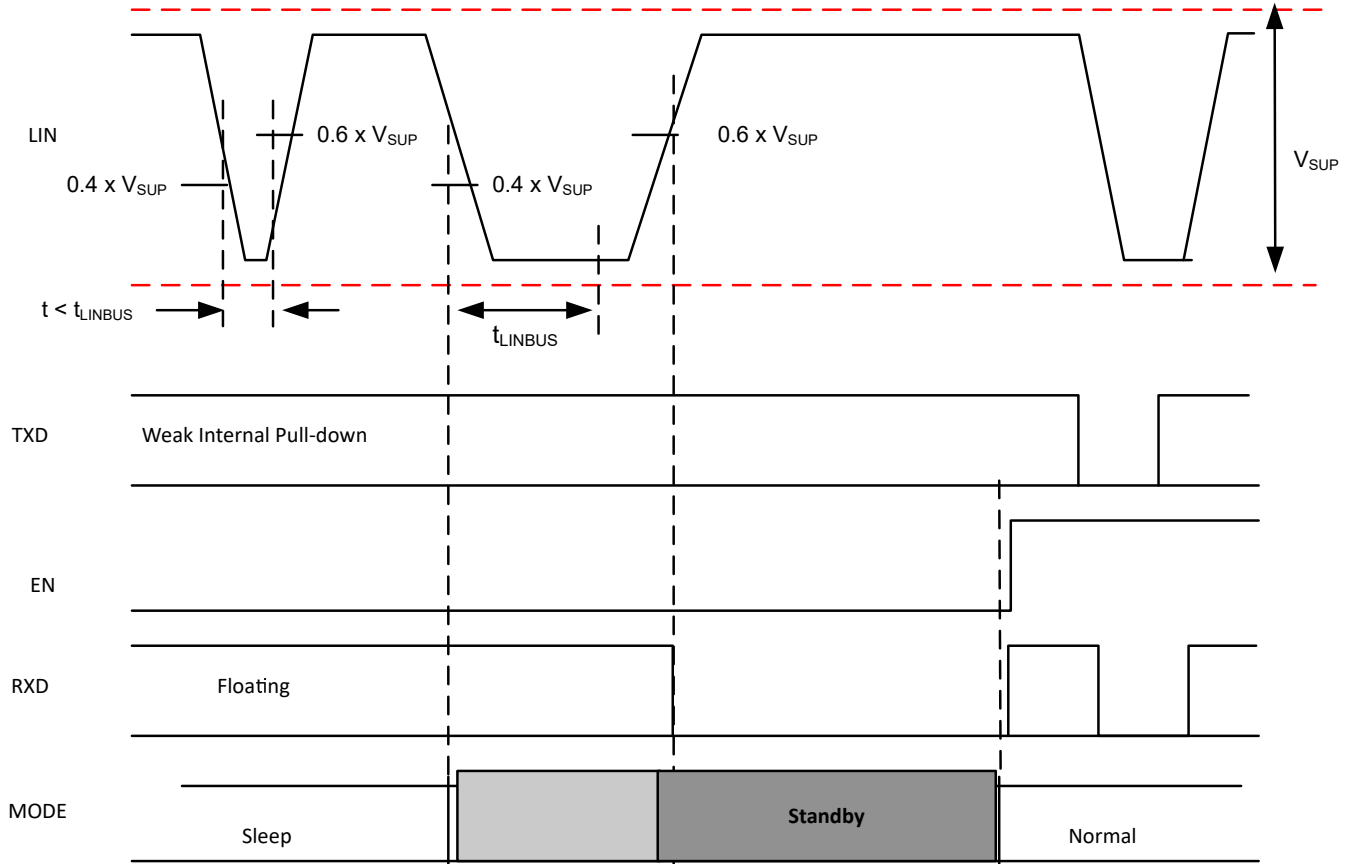
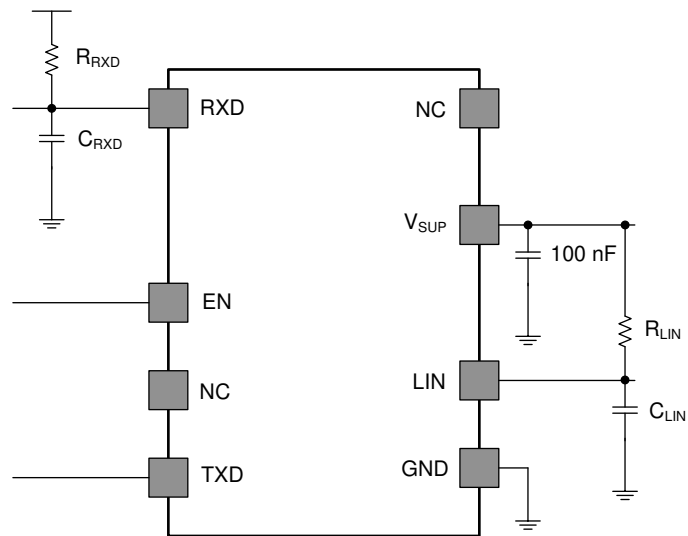
8 Detailed Description

8.1 Overview

The TLIN1027-Q1 is a Local Interconnect Network (LIN) physical layer transceiver, compatible with LIN 2.0, LIN 2.1, LIN 2.2, LIN 2.2A and ISO/DIS 17987 - 4 standards, with integrated wake-up and protection features. The LIN bus is a single-wire bidirectional bus typically used for low speed in-vehicle networks using data rates from 2.4 kbps to 20 kbps. The TLIN1027-Q1 LIN receiver works up to 100 kbps supporting in-line programming. The LIN protocol data stream on the TXD input is converted by the TLIN1027-Q1 into a LIN bus signal using a current-limited wave-shaping driver as outlined by the LIN physical layer specification. The receiver converts the data stream to logic-level signals that are sent to the microprocessor through the open-drain RXD pin. The LIN bus has two states: dominant state (voltage near ground) and recessive state (voltage near battery). In the recessive state, the LIN bus is pulled high by the internal pull-up resistor (45 k Ω) and a series diode. No external pull-up components are required for responder mode applications. Commander mode applications require an external pull-up resistor (1 k Ω) plus a series diode per the LIN specification. The TLIN1027-Q1 provides many protection features such as immunity to ESD and high bus standoff voltage. The device also provides two methods to wake up: EN pin and from the LIN bus.

8.2 Functional Block Diagram

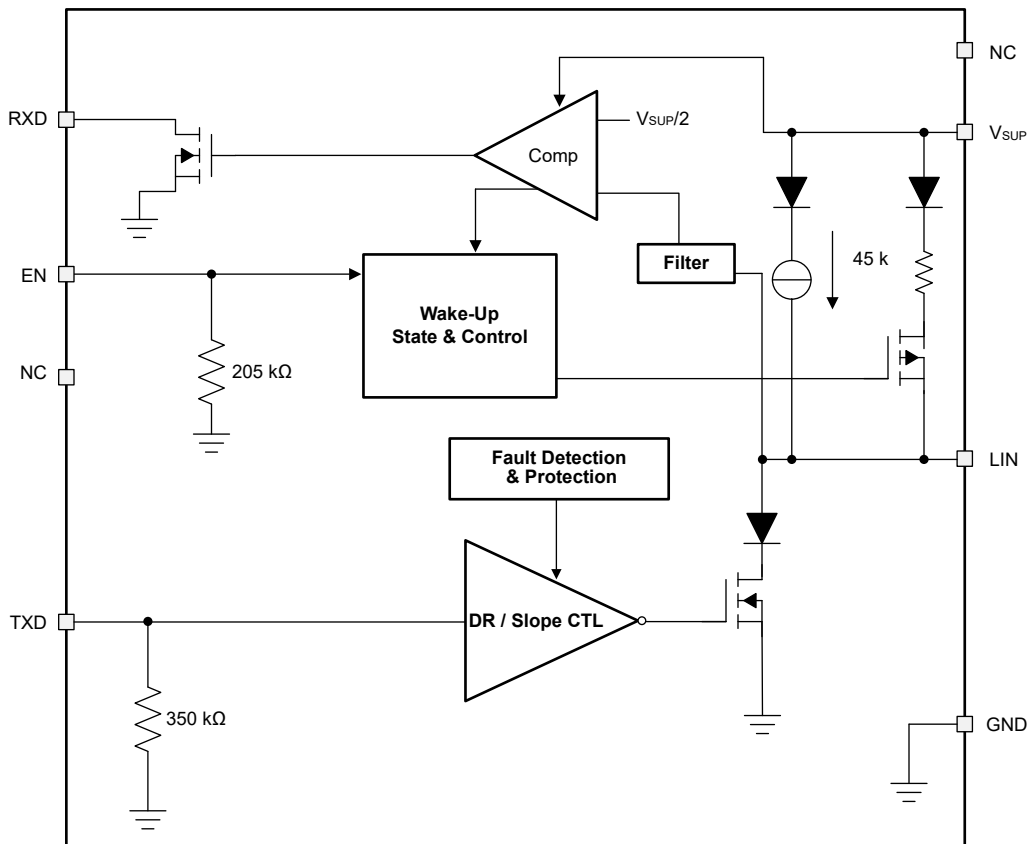

8.3 Feature Description

8.3.1 LIN (Local Interconnect Network) Bus

This high voltage input/output pin is a single-wire LIN bus transmitter and receiver. The LIN pin can survive transient voltages up to 45 V. Reverse currents from the LIN to supply (V_{SUP}) are minimized with blocking diodes, even in the event of a ground shift or loss of supply (V_{SUP}).

8.3.1.1 LIN Transmitter Characteristics

The transmitter has thresholds and AC parameters according to the LIN specification. The transmitter is a low-side transistor with internal current limitation and thermal shutdown. During a thermal shut-down condition, the

transmitter is disabled to protect the device. There is an internal pull-up resistor with a serial diode structure to V_{SUP} , so no external pull-up components are required for the LIN responder mode applications. An external pull-up resistor and series diode to V_{SUP} must be added when the device is used for a commander mode node application.

8.3.1.2 LIN Receiver Characteristics

The receiver's characteristic thresholds are proportional to the device supply pin in accordance to the LIN specification.

The receiver is capable of receiving higher data rates (> 100 kbps) than supported by LIN or SAEJ2602 specifications. This allows the TLIN1027-Q1 to be used for high speed downloads at the end-of-line production or other applications. The actual data rate achievable depends on system time constants (bus capacitance and pull-up resistance) and driver characteristics used in the system.

8.3.1.2.1 Termination

There is an internal pull-up resistor with a serial diode structure to V_{SUP} , so no external pull-up components are required for the LIN responder mode applications. An external pull-up resistor ($1\text{ k}\Omega$) and a series diode to V_{SUP} must be added when the device is used for com mode applications as per the LIN specification.

图 8-1 shows a commander node configuration and how the voltage levels are defined



图 8-1. Commander Node Configuration with Voltage Levels

8.3.2 TXD (Transmit Input and Output)

TXD is the interface to the MCU's LIN protocol controller or SCI and UART that is used to control the state of the LIN output. When TXD is low the LIN output is dominant (near ground). When TXD is high the LIN output is recessive (near $V_{Battery}$). See 图 8-1. The TXD input structure is compatible with microcontrollers with 3.3 V and 5 V I/O.

8.3.3 RXD (Receive Output)

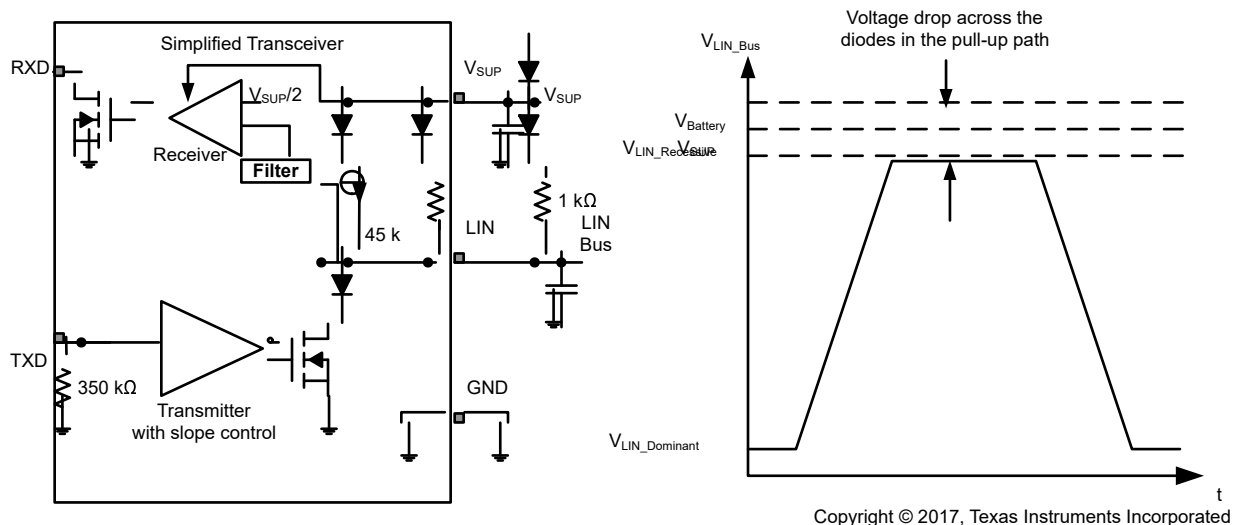
RXD is the interface to the MCU's LIN protocol controller or SCI and UART, which reports the state of the LIN bus voltage. LIN recessive (near $V_{Battery}$) is represented by a high level on the RXD and LIN dominant (near ground) is represented by a low level on the RXD pin. The RXD output structure is an open-drain output stage. This allows the device to be used with 3.3 V and 5 V I/O microcontrollers. If the microcontroller's RXD pin does not have an integrated pull-up, an external pull-up resistor to the microcontroller I/O supply voltage is required. In standby mode the RXD pin is driven low to indicate a wake-up request from the LIN bus.

8.3.4 V_{SUP} (Supply Voltage)

V_{SUP} is the power supply pin. V_{SUP} is connected to the battery through an external reverse-blocking diode (图 8-1). If there is a loss of power at the ECU level, the device has extremely low leakage from the LIN pin, which does not load the bus down. This is optimal for LIN systems in which some of the nodes are unpowered (ignition supplied) while the rest of the network remains powered (battery supplied).

8.3.5 GND (Ground)

GND is the device ground connection. The device can operate with a ground shift as long as the ground shift does not reduce the V_{SUP} below the minimum operating voltage, as well as ensuring the input and output voltages are within their appropriate thresholds. If there is a loss of ground at the ECU level, the device has extremely low leakage from the LIN pin, which does not load the bus down. This is optimal for LIN systems in which some of the nodes are unpowered (ignition supplied) while the rest of the network remains powered (battery supplied).

8.3.6 EN (Enable Input)

EN controls the operational modes of the device. When EN is high the device is in normal operating mode allowing a transmission path from TXD to LIN and from LIN to RXD. When EN is low the device is put into sleep mode and there are no transmission paths available. The device can enter normal mode only after wake-up. EN has an internal pull-down resistor to ensure the device remains in low-power mode even if EN floats.

8.3.7 Protection Features

The TLIN1027-Q1 has several protection features, described below.

8.3.8 Bus Stuck Dominant System Fault: False Wake-Up Lockout

The TLIN1027-Q1 contains logic to detect bus stuck dominant system faults and prevents the device from waking up falsely during the system fault. Upon entering sleep mode, the device detects the state of the LIN bus. If the bus is dominant, the wake-up logic is locked out until a valid recessive on the bus “clears” the bus stuck dominant, preventing excessive current consumption. 图 8-2 and 图 8-3 show the behavior of this protection.



图 8-2. No Bus Fault: Entering Sleep Mode with Bus Recessive Condition and Wake-Up



图 8-3. Bus Fault: Entering Sleep Mode with Bus Stuck Dominant Fault, Clearing, and Wake-Up

8.3.9 Thermal Shutdown

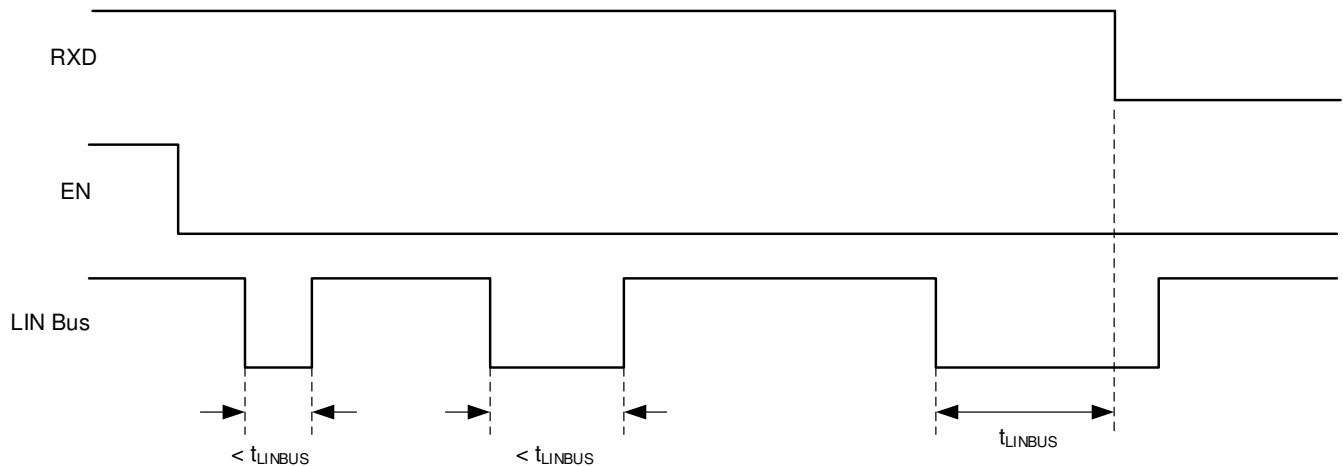
The LIN transmitter is protected by current limiting circuitry; however, if the junction temperature of the device exceeds the thermal shutdown threshold, the device puts the LIN transmitter into the recessive state. Once the over-temperature fault condition has been removed and the junction temperature has cooled beyond the hysteresis temperature, the transmitter is re-enabled, assuming the device remained in the normal operation mode. During this fault, the transceiver remains in normal mode (assuming no change of state request on EN), the transmitter is in recessive state, the RXD pin reflects the LIN bus and LIN bus pull-up termination remains on.

8.3.10 Under Voltage on V_{SUP}

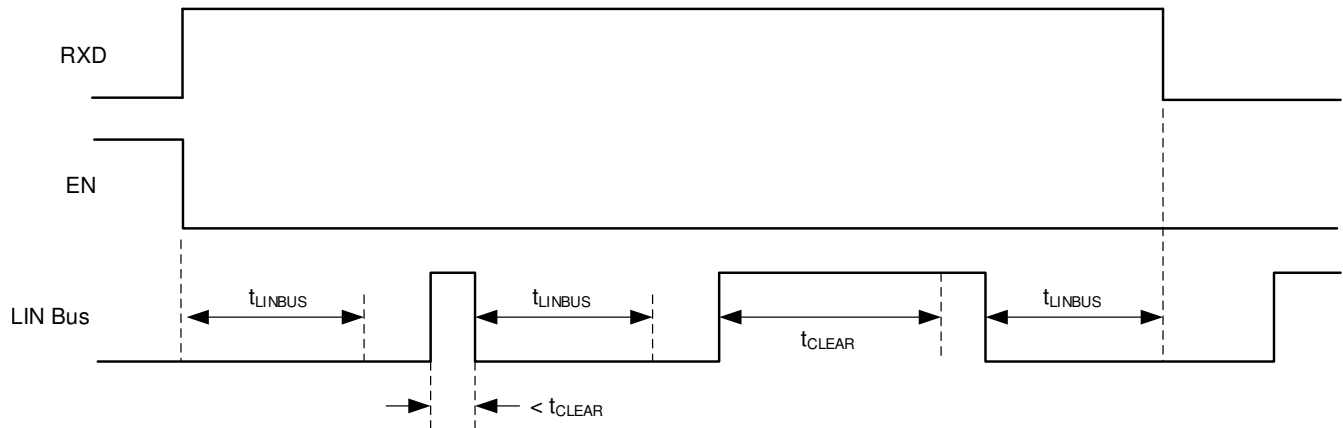
The TLIN1027-Q1 contains a power-on reset circuit to avoid false bus messages during under voltage conditions when V_{SUP} is less than UV_{SUP} .

8.3.11 Unpowered Device and LIN Bus

In automotive applications some LIN nodes in a system can be unpowered (ignition supplied) while others in the network remain powered by the battery. The TLIN1027-Q1 has extremely low unpowered leakage current from the bus so an unpowered node does not affect the network or load it down.

8.4 Device Functional Modes

The TLIN1027-Q1 has three functional modes of operation: normal, sleep, and standby. The next sections will describe these modes as well as how the device moves between the different modes. 图 8-4 graphically shows the relationship while 表 8-1 shows the state of pins.

表 8-1. Operating Modes

MODE	EN	RXD	LIN BUS TERMINATION	TRANSMITTER	COMMENT
Sleep	Low	Floating	Weak current pull-up	Off	
Standby	Low	Low	45 kΩ (typical)	Off	Wake-up event detected, waiting on MCU to set EN
Normal	High	LIN bus data	45 kΩ (typical)	On	LIN transmission up to 20 kbps

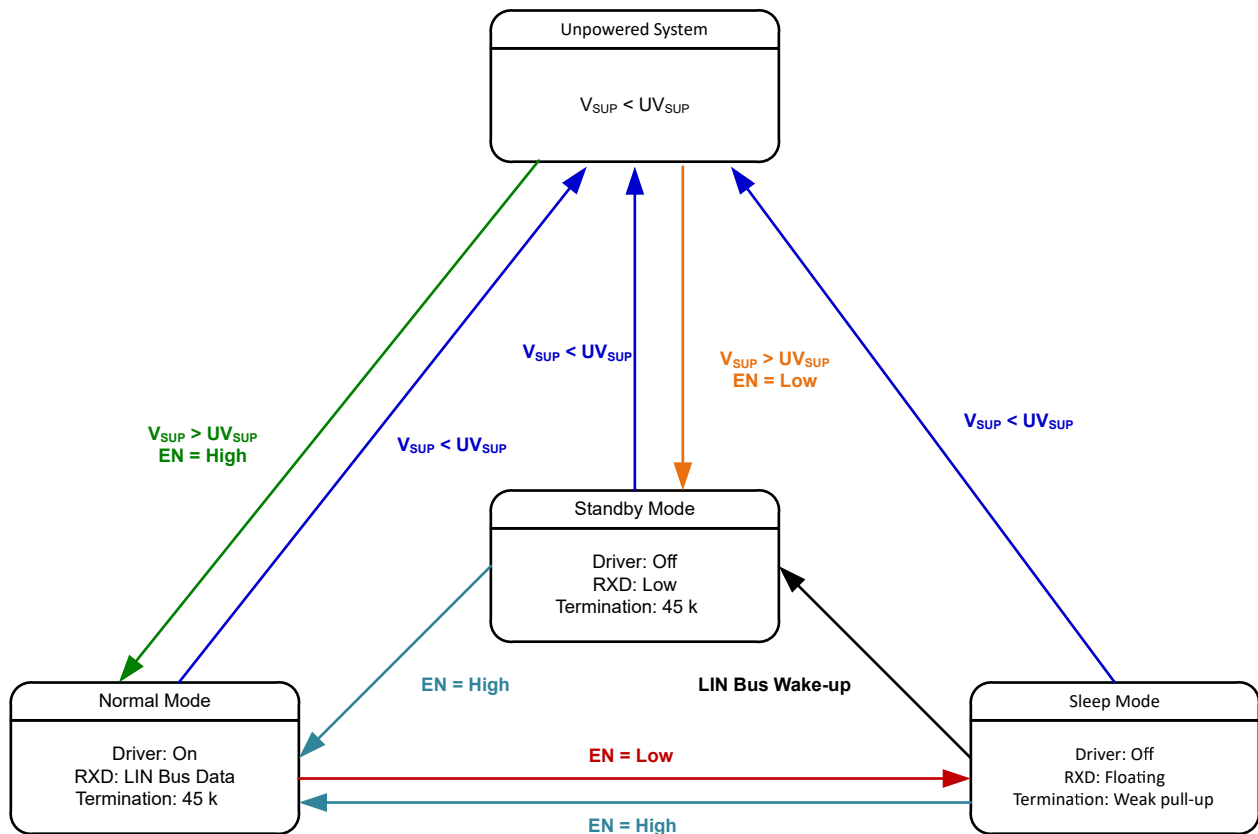

Copyright © 2017, Texas Instruments Incorporated

图 8-4. Operating State Diagram

8.4.1 Normal Mode

If the EN pin is high at power up the device will power up in normal mode. If the EN pin is low, it will power up in standby mode. The EN pin controls the mode of the device. In normal operational mode the receiver and transmitter are active and the LIN transmission up to the LIN specified maximum of 20 kbps is supported. The receiver detects the data stream on the LIN bus and outputs it on RXD for the LIN controller. A recessive signal on the LIN bus is a logic high and a dominant signal on the LIN bus is a logic low. The driver transmits input data from TXD to the LIN bus. Normal mode is entered as EN transitions high while the TLIN1027-Q1 is in sleep or standby mode for $> t_{MODE_CHANGE}$ plus t_{NOMINT} .

8.4.2 Sleep Mode

Sleep mode is the power saving mode for the TLIN1027-Q1. Sleep mode is only entered when the EN pin is low and from normal mode. Even with extremely low current consumption in this mode, the TLIN1027-Q1 can still wake up from LIN bus through a wake-up signal or if EN is set high for $\geq t_{\text{MODE_CHANGE}}$. The LIN bus is filtered to prevent false wake-up events. The wake-up events must be active for the respective time periods (t_{LINBUS}).

The sleep mode is entered by setting EN low for longer than $t_{\text{MODE_CHANGE}}$.

While the device is in sleep mode, the following conditions exist:

- The LIN bus driver is disabled and the internal LIN bus termination is switched off (to minimize power loss if LIN is short circuited to ground). However, the weak current pull-up is active to prevent false wake-up events in case an external connection to the LIN bus is lost.
- The normal receiver is disabled.
- EN input and LIN wake-up receiver are active.

8.4.3 Standby Mode

This mode is entered whenever a wake-up event occurs through LIN bus while the device is in sleep mode. The LIN bus responder mode termination circuit is turned on when standby mode is entered. Standby mode is signaled through a low level on RXD. See [# 9.2.2.2](#) for more application information.

When EN is set high for longer than $t_{\text{MODE_CHANGE}}$ while the device is in standby mode, the device returns to normal mode. The normal transmission paths from TXD to LIN bus and LIN bus to RXD are enabled.

8.4.4 Wake-Up Events

There are two ways to wake up from sleep mode:

- Remote wake-up initiated by the falling edge of a recessive (high) to dominant (low) state transition on LIN bus where the dominant state is held for t_{LINBUS} filter time. After this t_{LINBUS} filter time has been met and a rising edge on the LIN bus going from dominant state to recessive state initiates a remote wake-up event, eliminating false wake-ups from disturbances on the LIN bus or if the bus is shorted to ground.
- Local wake-up through EN being set high for longer than $t_{\text{MODE_CHANGE}}$.

8.4.4.1 Wake-Up Request (RXD)

When the TLIN1027-Q1 encounters a wake-up event from the LIN bus, RXD goes low and the device transitions to standby mode until EN is reasserted high and the device enters normal mode. Once the device enters normal mode, the RXD pin releases the wake-up request signal and the RXD pin then reflects the receiver output from the LIN bus.

8.4.4.2 Mode Transitions

When the TLIN1027-Q1 is transitioning from normal to sleep or standby modes the device needs the time $t_{\text{MODE_CHANGE}}$ to allow the change to fully propagate from the EN pin through the device into the new state. When transitioning from sleep or standby to normal mode the device needs $t_{\text{MODE_CHANGE}}$ plus t_{NOMINT} .

9 Application and Implementation

备注

Information in the following applications sections is not part of the TI component specification, and TI does not warrant its accuracy or completeness. TI's customers are responsible for determining suitability of components for their purposes. Customers should validate and test their design implementation to confirm system functionality.

9.1 Application Information

The TLIN1027-Q1 can be used as both a responder node device and a commander node device in a LIN network. The device comes with the ability to support both remote wake-up request and local wake-up request.

9.2 Typical Application

The device integrates a 45 kΩ pull-up resistor and series diode for responder node applications. For commander applications an external 1 kΩ pull-up resistor with series blocking diode can be used. 图 9-1 shows the device being used in both commander mode and responder mode applications.

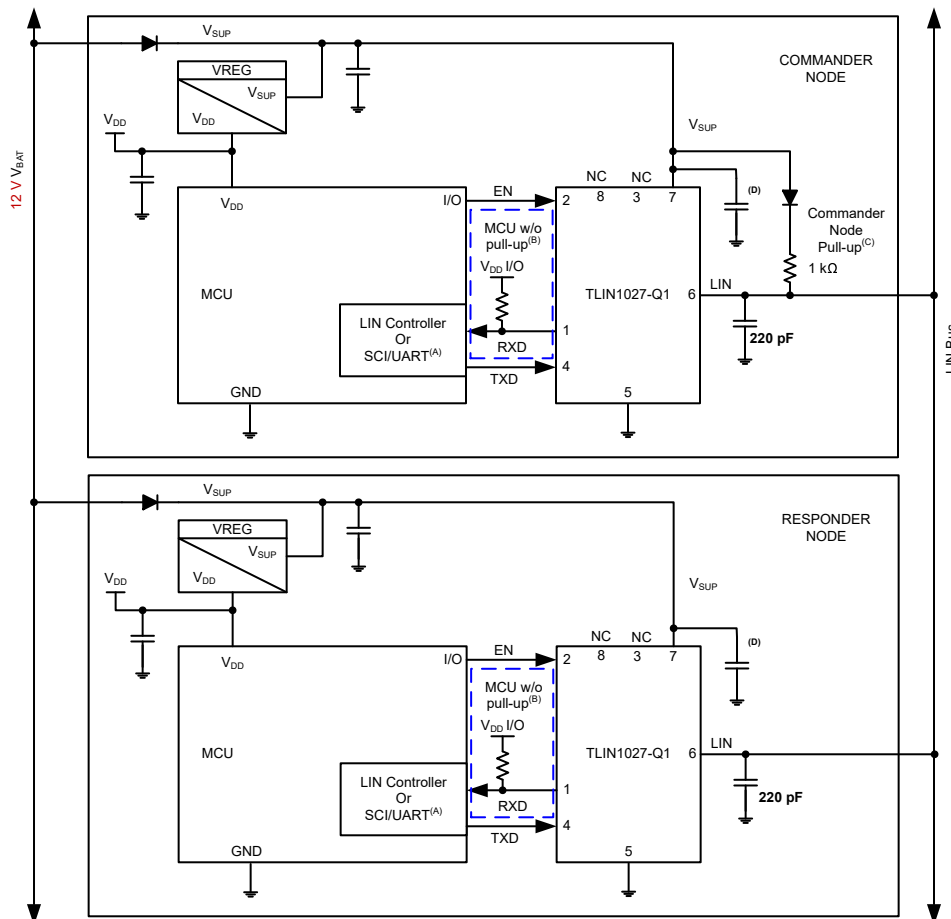

- A. If RXD on MCU on LIN responder node has internal pull-up, no external pull-up resistor is needed.
- B. If RXD on MCU on LIN responder node does not have an internal pull-up, requires external pull-up resistor.
- C. Commander node applications require an external 1 kΩ pull-up resistor and serial diode.
- D. Decoupling capacitor values are system dependent but usually have 100 nF, 1 μF and $\geq 10 \mu\text{F}$.

图 9-1. Typical LIN Bus

9.2.1 Design Requirements

The RXD output structure is an open-drain output stage. This allows the TLIN1027-Q1 to be used with 3.3-V and 5-V I/O processor. If the RXD pin of the processor does not have an integrated pull-up, an external pull-up resistor to the processor I/O supply voltage is required. The select external pull-up resistor value should be between 1 k Ω to 10 k Ω , depending on supply used (See I_{OL} in electrical characteristics). The V_{SUP} pin of the device should be decoupled with a 100-nF capacitor as close to the supply pin of the device as possible.

9.2.2 Detailed Design Procedures

9.2.2.1 Normal Mode Application Note

When using the TLIN1027-Q1 in systems which are monitoring the RXD pin for a wake-up request, special care should be taken during the mode transitions. The output of the RXD pin is indeterminate for the transition period between states as the receivers are switched. The application software should not look for an edge on the RXD pin indicating a wake-up request until t_{MODE_CHANGE}. This is shown in 图 7-15

9.2.2.2 Standby Mode Application Note

If the TLIN1027-Q1 detects an under voltage on V_{SUP} the RXD pin transitions low and would signal to the software that the TLIN1027-Q1 is in standby mode and should be returned to sleep mode for the lowest power state.

9.2.3 Application Curves

The below figures show the propagation delay from the TXD pin to the LIN pin for both dominant to recessive and recessive to dominant stated under lightly loaded conditions.



图 9-2. Recessive to Dominant Propagation



图 9-3. Dominant to Recessive Propagation

10 Power Supply Recommendations

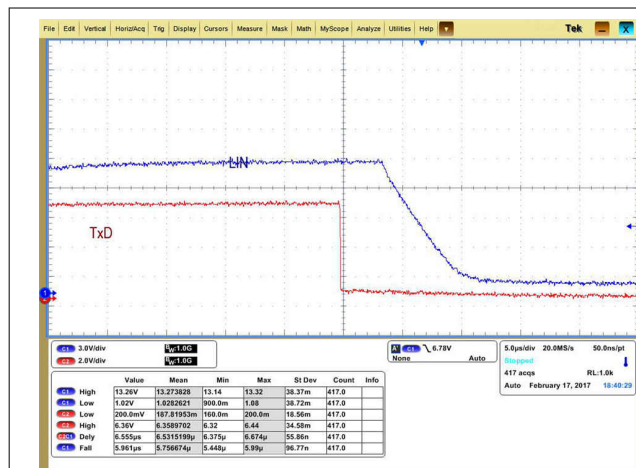
The TLIN1027-Q1 was designed to operate directly off a car battery, or any other DC supply ranging from 4 V to 36 V. A 100 nF decoupling capacitor should be placed as close to the V_{SUP} pin of the device as possible. It is good practice for some applications with noisier supplies to include 1 μ F and 10 μ F decoupling capacitor, as well.

11 Layout

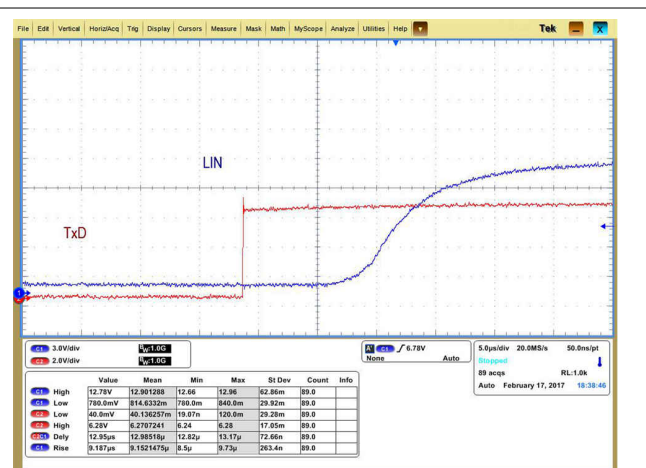
In order for your PCB design to be successful, start with design of the protection and filtering circuitry. Because ESD transients have a wide frequency bandwidth from approximately 3 MHz to 3 GHz, high frequency layout techniques must be applied during PCB design. Placement at the connector also prevents these noisy events from propagating further into the PCB and system.

11.1 Layout Guidelines

- **Pin 1 (RXD):** The pin is an open-drain output and requires an external pull-up resistor in the range of 1 k Ω to 10 k Ω to function properly. Note that the minimum value will depend on the VIO supply used. See I_{OL} in electrical specifications. If the microprocessor paired with the transceiver does not have an integrated pull-up, an external resistor should be placed between RXD and the regulated voltage supply for the microprocessor.
- **Pin 2 (EN):** EN is an input pin that is used to place the device in a low-power sleep mode. If this feature is not used the pin should be pulled high to the regulated voltage supply of the microprocessor through a series resistor between 1 k Ω and 10 k Ω . Additionally, a series resistor may be placed on the pin to limit current on the digital lines in the case of an over voltage fault.
- **Pin 3 (NC):** Not Connected.
- **Pin 4 (TXD):** The TXD pin is used to transmit the input signal from the microcontroller. A series resistor can be placed to limit the input current to the device in the case of an over-voltage on this pin. A capacitor to ground can be placed close to the input pin of the device to filter noise.
- **Pin 5 (GND):** This is the ground connection for the device. This pin should be tied to the ground plane through a short trace with the use of two vias to limit total return inductance.
- **Pin 6 (LIN):** This pin connects to the LIN bus. For responder mode applications, a 220 pF capacitor to ground is implemented. For commander mode applications, an additional series resistor and blocking diode should be placed between the LIN pin and the V_{SUP} pin. See [图 9-1](#).
- **Pin 7 (VSUP):** This is the supply pin for the device. A 100 nF decoupling capacitor should be placed as close to the device as possible.
- **Pin 8 (NC):** Not Connected.

备注

All ground and power connections should be made as short as possible and use at least two vias to minimize the total loop inductance.

11.2 Layout Example



图 11-1. Layout Example

12 Device and Documentation Support

12.1 Documentation Support

12.1.1 Related Documentation

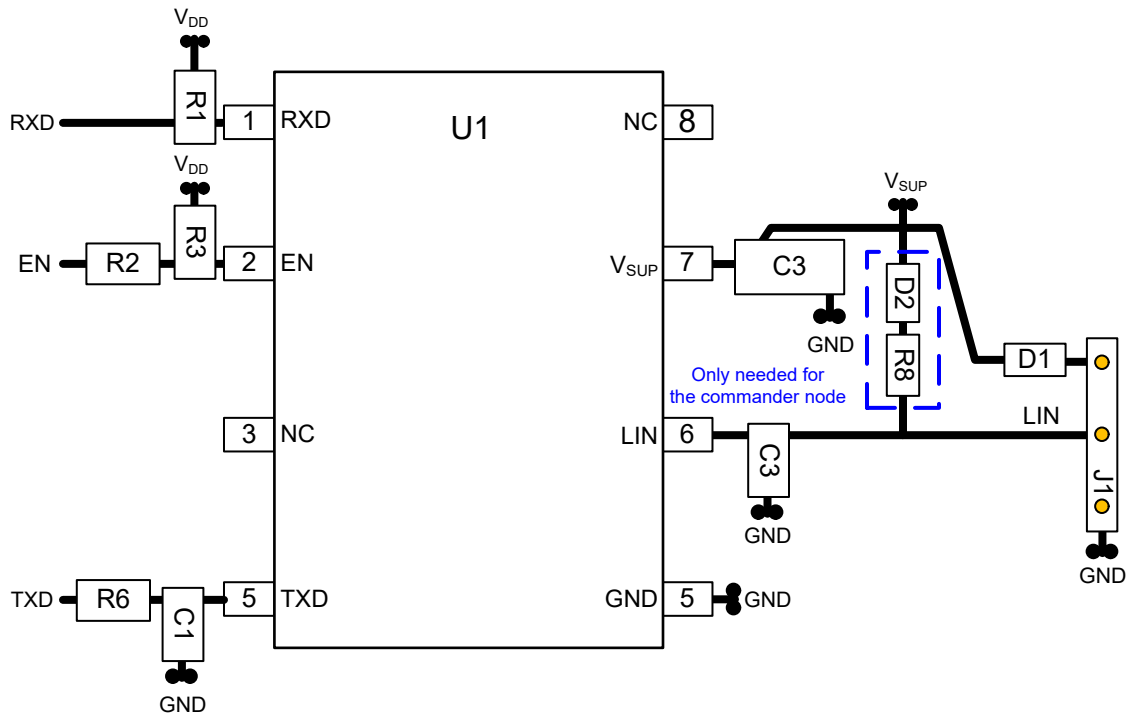
For related documentation see the following:

- LIN Standards:
 - ISO/DIS 17987-1: Road vehicles -- Local Interconnect Network (LIN) -- Part 1: General information and use case definition
 - ISO/DIS 17987-4: Road vehicles -- Local Interconnect Network (LIN) -- Part 4: Electrical Physical Layer (EPL) specification 12V/24V
 - SAEJ2602-1: LIN Network for Vehicle Applications
 - LIN Specifications LIN 2.0, LIN 2.1, LIN 2.2 and LIN 2.2A
- EMC requirements:
 - SAEJ2962-1: Communication Transceivers Qualification Requirements - LIN
 - ISO 10605: Road vehicles - Test methods for electrical disturbances from electrostatic discharge
 - ISO 11452-4:2011: Road vehicles - Component test methods for electrical disturbances from narrowband radiated electromagnetic energy - Part 4: Harness excitation methods
 - ISO 7637-1:2015: Road vehicles - Electrical disturbances from conduction and coupling - Part 1: Definitions and general considerations
 - ISO 7637-3: Road vehicles - Electrical disturbances from conduction and coupling - Part 3: Electrical transient transmission by capacitive and inductive coupling via lines other than supply lines
 - IEC 62132-4:2006: Integrated circuits - Measurement of electromagnetic immunity 150 kHz to 1 GHz - Part 4: Direct RF power injection method
 - IEC 61000-4-2
 - IEC 61967-4
 - CISPR25
- Conformance Test requirements:
 - ISO/DIS 17987-7.2: Road vehicles -- Local Interconnect Network (LIN) -- Part 7: Electrical Physical Layer (EPL) conformance test specification
 - SAEJ2602-2: LIN Network for Vehicle Applications Conformance Test
-

12.2 Receiving Notification of Documentation Updates

To receive notification of documentation updates, navigate to the device product folder on ti.com. In the upper right corner, click on *Alert me* to register and receive a weekly digest of any product information that has changed. For change details, review the revision history included in any revised document.

12.3 支持资源

[TI E2E™ 支持论坛](#)是工程师的重要参考资料，可直接从专家获得快速、经过验证的解答和设计帮助。搜索现有解答或提出自己的问题可获得所需的快速设计帮助。

链接的内容由各个贡献者“按原样”提供。这些内容并不构成 TI 技术规范，并且不一定反映 TI 的观点；请参阅 TI 的《[使用条款](#)》。

12.4 Trademarks

TI E2E™ is a trademark of Texas Instruments.
所有商标均为其各自所有者的财产。

12.5 Electrostatic Discharge Caution



This integrated circuit can be damaged by ESD. Texas Instruments recommends that all integrated circuits be handled with appropriate precautions. Failure to observe proper handling and installation procedures can cause damage.

ESD damage can range from subtle performance degradation to complete device failure. Precision integrated circuits may be more susceptible to damage because very small parametric changes could cause the device not to meet its published specifications.

12.6 术语表

TI 术语表

本术语表列出并解释了术语、首字母缩略词和定义。

13 Mechanical, Packaging, and Orderable Information

The following pages include mechanical, packaging, and orderable information. This information is the most current data available for the designated devices. This data is subject to change without notice and revision of this document. For browser-based versions of this data sheet, refer to the left-hand navigation.

PACKAGING INFORMATION

Orderable part number	Status (1)	Material type (2)	Package Pins	Package qty Carrier	RoHS (3)	Lead finish/ Ball material (4)	MSL rating/ Peak reflow (5)	Op temp (°C)	Part marking (6)
TLIN1027DRBRQ1	Active	Production	SON (DRB) 8	3000 LARGE T&R	Yes	NIPDAU	Level-2-260C-1 YEAR	-40 to 125	TL027
TLIN1027DRBRQ1.A	Active	Production	SON (DRB) 8	3000 LARGE T&R	Yes	NIPDAU	Level-2-260C-1 YEAR	-40 to 125	TL027
TLIN1027DRQ1	Active	Production	SOIC (D) 8	2500 LARGE T&R	Yes	NIPDAU NIPDAUAG	Level-1-260C-UNLIM	-40 to 125	TL027
TLIN1027DRQ1.A	Active	Production	SOIC (D) 8	2500 LARGE T&R	Yes	NIPDAU	Level-1-260C-UNLIM	-40 to 125	TL027

(1) **Status:** For more details on status, see our [product life cycle](#).

(2) **Material type:** When designated, preproduction parts are prototypes/experimental devices, and are not yet approved or released for full production. Testing and final process, including without limitation quality assurance, reliability performance testing, and/or process qualification, may not yet be complete, and this item is subject to further changes or possible discontinuation. If available for ordering, purchases will be subject to an additional waiver at checkout, and are intended for early internal evaluation purposes only. These items are sold without warranties of any kind.

(3) **RoHS values:** Yes, No, RoHS Exempt. See the [TI RoHS Statement](#) for additional information and value definition.

(4) **Lead finish/Ball material:** Parts may have multiple material finish options. Finish options are separated by a vertical ruled line. Lead finish/Ball material values may wrap to two lines if the finish value exceeds the maximum column width.

(5) **MSL rating/Peak reflow:** The moisture sensitivity level ratings and peak solder (reflow) temperatures. In the event that a part has multiple moisture sensitivity ratings, only the lowest level per JEDEC standards is shown. Refer to the shipping label for the actual reflow temperature that will be used to mount the part to the printed circuit board.

(6) **Part marking:** There may be an additional marking, which relates to the logo, the lot trace code information, or the environmental category of the part.

Multiple part markings will be inside parentheses. Only one part marking contained in parentheses and separated by a "~" will appear on a part. If a line is indented then it is a continuation of the previous line and the two combined represent the entire part marking for that device.

Important Information and Disclaimer: The information provided on this page represents TI's knowledge and belief as of the date that it is provided. TI bases its knowledge and belief on information provided by third parties, and makes no representation or warranty as to the accuracy of such information. Efforts are underway to better integrate information from third parties. TI has taken and continues to take reasonable steps to provide representative and accurate information but may not have conducted destructive testing or chemical analysis on incoming materials and chemicals. TI and TI suppliers consider certain information to be proprietary, and thus CAS numbers and other limited information may not be available for release.

In no event shall TI's liability arising out of such information exceed the total purchase price of the TI part(s) at issue in this document sold by TI to Customer on an annual basis.

TAPE AND REEL INFORMATION

QUADRANT ASSIGNMENTS FOR PIN 1 ORIENTATION IN TAPE

*All dimensions are nominal

Device	Package Type	Package Drawing	Pins	SPQ	Reel Diameter (mm)	Reel Width W1 (mm)	A0 (mm)	B0 (mm)	K0 (mm)	P1 (mm)	W (mm)	Pin1 Quadrant
TLIN1027DRBRQ1	SON	DRB	8	3000	330.0	12.4	3.3	3.3	1.1	8.0	12.0	Q2

TAPE AND REEL BOX DIMENSIONS

*All dimensions are nominal

Device	Package Type	Package Drawing	Pins	SPQ	Length (mm)	Width (mm)	Height (mm)
TLIN1027DRBRQ1	SON	DRB	8	3000	367.0	367.0	35.0

DRB 8

GENERIC PACKAGE VIEW

VSON - 1 mm max height

PLASTIC SMALL OUTLINE - NO LEAD



Images above are just a representation of the package family, actual package may vary.
Refer to the product data sheet for package details.

4203482/L

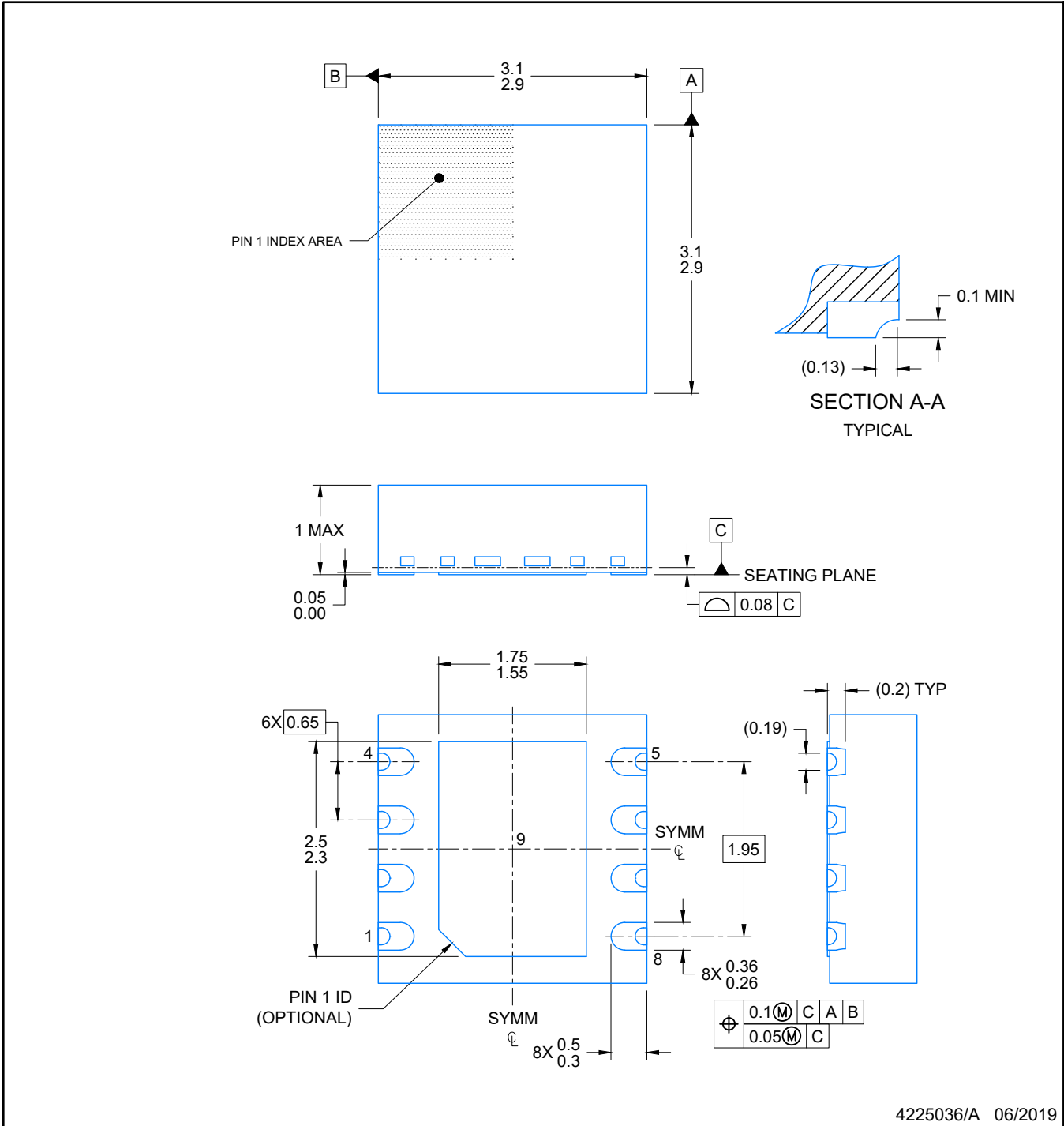

4225036/A 06/2019

NOTES:

1. All linear dimensions are in millimeters. Any dimensions in parenthesis are for reference only. Dimensioning and tolerancing per ASME Y14.5M.
2. This drawing is subject to change without notice.
3. The package thermal pad must be soldered to the printed circuit board for optimal thermal and mechanical performance.

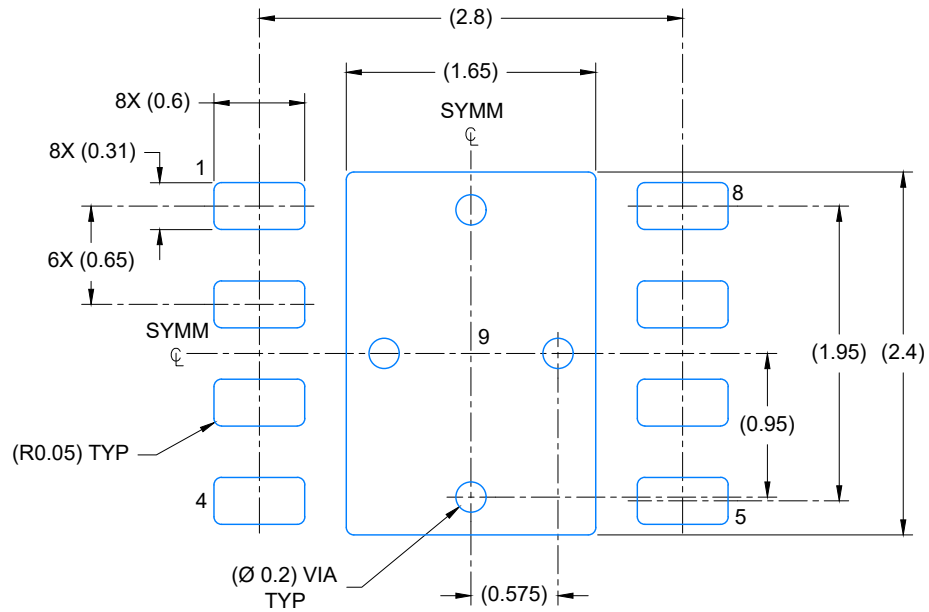

LAND PATTERN EXAMPLE
EXPOSED METAL SHOWN
SCALE: 20X

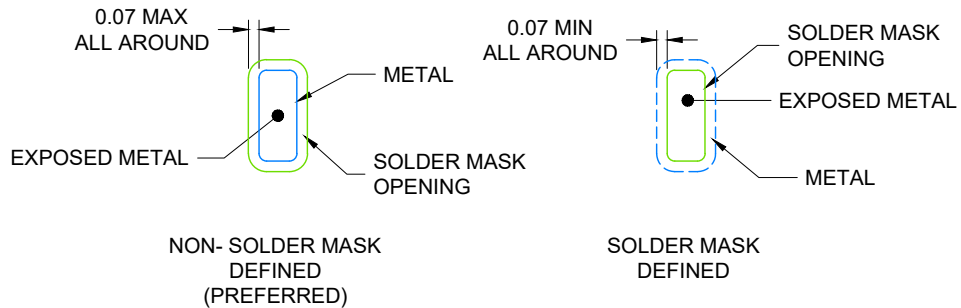

SOLDER MASK DETAILS

4225036/A 06/2019

NOTES: (continued)

4. This package is designed to be soldered to a thermal pad on the board. For more information, see Texas Instruments literature number SLUA271 (www.ti.com/lit/sluea271).
5. Vias are optional depending on application, refer to device data sheet. If any vias are implemented, refer to their locations shown on this view. It is recommended that vias under paste be filled, plugged or tented.

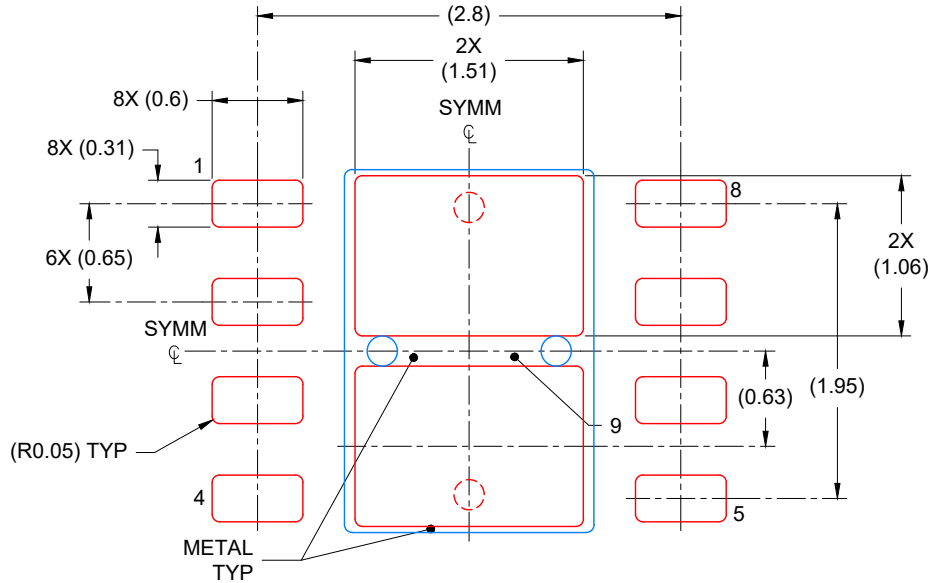

SOLDER PASTE EXAMPLE
 BASED ON 0.125 mm THICK STENCIL

EXPOSED PAD
 81% PRINTED COVERAGE BY AREA
 SCALE: 20X

4225036/A 06/2019

NOTES: (continued)

6. Laser cutting apertures with trapezoidal walls and rounded corners may offer better paste release. IPC-7525 may have alternate design recommendations.

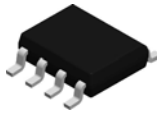

D0008A

PACKAGE OUTLINE

SOIC - 1.75 mm max height

SMALL OUTLINE INTEGRATED CIRCUIT

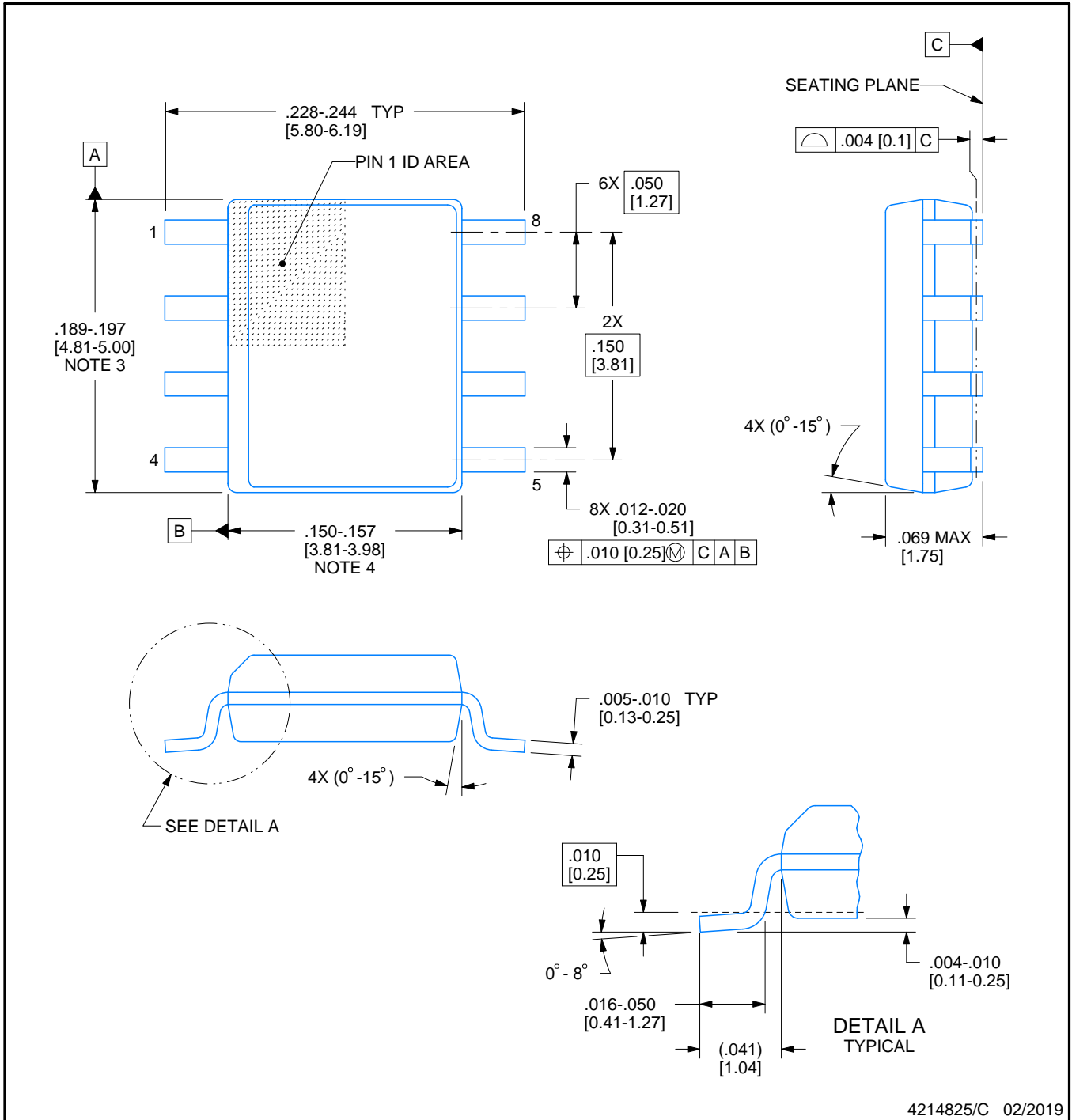

4214825/C 02/2019

NOTES:

1. Linear dimensions are in inches [millimeters]. Dimensions in parenthesis are for reference only. Controlling dimensions are in inches. Dimensioning and tolerancing per ASME Y14.5M.
2. This drawing is subject to change without notice.
3. This dimension does not include mold flash, protrusions, or gate burrs. Mold flash, protrusions, or gate burrs shall not exceed $.006$ [0.15] per side.
4. This dimension does not include interlead flash.
5. Reference JEDEC registration MS-012, variation AA.

EXAMPLE BOARD LAYOUT

D0008A

SOIC - 1.75 mm max height

SMALL OUTLINE INTEGRATED CIRCUIT



LAND PATTERN EXAMPLE
 EXPOSED METAL SHOWN
 SCALE:8X



SOLDER MASK DETAILS

4214825/C 02/2019

NOTES: (continued)

- 6. Publication IPC-7351 may have alternate designs.
- 7. Solder mask tolerances between and around signal pads can vary based on board fabrication site.

EXAMPLE STENCIL DESIGN

D0008A

SOIC - 1.75 mm max height

SMALL OUTLINE INTEGRATED CIRCUIT



SOLDER PASTE EXAMPLE
BASED ON .005 INCH [0.125 MM] THICK STENCIL
SCALE:8X

4214825/C 02/2019

NOTES: (continued)

8. Laser cutting apertures with trapezoidal walls and rounded corners may offer better paste release. IPC-7525 may have alternate design recommendations.
9. Board assembly site may have different recommendations for stencil design.

重要通知和免责声明

TI“按原样”提供技术和可靠性数据（包括数据表）、设计资源（包括参考设计）、应用或其他设计建议、网络工具、安全信息和其他资源，不保证没有瑕疵且不做任何明示或暗示的担保，包括但不限于对适销性、与某特定用途的适用性或不侵犯任何第三方知识产权的暗示担保。

这些资源可供使用 TI 产品进行设计的熟练开发人员使用。您将自行承担以下全部责任：(1) 针对您的应用选择合适的 TI 产品，(2) 设计、验证并测试您的应用，(3) 确保您的应用满足相应标准以及任何其他安全、安保法规或其他要求。

这些资源如有变更，恕不另行通知。TI 授权您仅可将这些资源用于研发本资源所述的 TI 产品的相关应用。严禁以其他方式对这些资源进行复制或展示。您无权使用任何其他 TI 知识产权或任何第三方知识产权。对于因您对这些资源的使用而对 TI 及其代表造成的任何索赔、损害、成本、损失和债务，您将全额赔偿，TI 对此概不负责。

TI 提供的产品受 [TI 销售条款](#)、[TI 通用质量指南](#) 或 [ti.com](#) 上其他适用条款或 TI 产品随附的其他适用条款的约束。TI 提供这些资源并不会扩展或以其他方式更改 TI 针对 TI 产品发布的适用的担保或担保免责声明。除非德州仪器 (TI) 明确将某产品指定为定制产品或客户特定产品，否则其产品均为按确定价格收入目录的标准通用器件。

TI 反对并拒绝您可能提出的任何其他或不同的条款。

版权所有 © 2025，德州仪器 (TI) 公司

最后更新日期：2025 年 10 月