

## SN75DP126 具有 TMDS 转换器的 DisplayPort™ 1:2 转接驱动器开关

### 1 特性

- 一个双模显示端口™(DP++) 输入；可切换至一个 DP++ 输出或者与一个高清多媒体接口 (HDMI) 1.4b 和数字视频接口 (DVI) 兼容的 TMDS 输出
- 支持包括 HBR2 数据速率达到 5.4 Gbps 在内的 DP v1.1a 和 DP v1.2 信令
- 支持线缆长度为 10 米且 TMDS 时钟频率高达 340 MHz 的 HDMI 1.4b
- 到 AMD, 英特尔, 和 NVIDIA 图形处理器的无粘逻辑接口
- 通过针对显示端口连接的链路协商的自动配置
- 针对 HDMI/DVI 接收端识别集成的可访问显示数据通道 (DDC) 的 DP-HDMI 适配器 ID
- 针对显示端口和 TMDS 输出的带有可调电压摆幅和预加重增益的输出信号调节
- 高可配置输入变量均衡器
- 两个含针对最低功率的双路电源配置的器件选项
- 2kV 静电放电 (ESD) 人体放电模式 (HBM) 保护
- 温度范围: 0°C 至 85°C
- 56 引脚 5mm x 11mm 四方扁平无引线 (QFN) 封装

### 2 应用

- 笔记本电脑
- 台式计算机
- 计算机扩展坞
- 计算机独立视频卡

### 3 说明

SN75DP126 将一个双模式显示端口 (DP++) 输入切换至一个双模式显示端口 (DP++) 接收端输出或者一个 HDMI/DVI 接收端输出。HDMI/DVI 输出有一个内置的与 DVI 1.0 和 HDMI 1.4b 标准 TMDS 信令兼容的电平转换器, 并且其最大额定数据速率高达 3.4Gbps, 从而支持大于 1920 x 1440 的分辨率以及 1080p 上的 HDTV 深色功能。当选择 HDMI/DVI 来表示支持 HDMI 信令的时候, 可访问一个集成的 DP-HDMI 适配器 ID 缓冲器。

此器件对与 PCB 相关的频率损失和切换相关的损失进行补偿以提供从源到接收端的最优的电气性能。DP++ 主链路信号输入到具有可选择升压设置的功能可配置均衡器。

在 SN75DP126 DP++ 主链路输出上, 可提供差分输出电压 ( $V_{OD}$ ) 摆幅的四个主级和预加重的四个主级以及升压调整的次级, 通过 I<sup>2</sup>C 编程, 用于对主链路输出的微调。此器件可监视 AUX 通道并自动调整输出信令电平和基于 DP 链路协商命令的输入均衡器。

器件信息<sup>(1)</sup>

| 器件型号      | 封装        | 封装尺寸 (标称值)       |
|-----------|-----------|------------------|
| SN75DP126 | WQFN (56) | 11.00mm x 5.00mm |

(1) 要了解所有可用封装, 请见数据表末尾的可订购产品附录。

### 典型应用

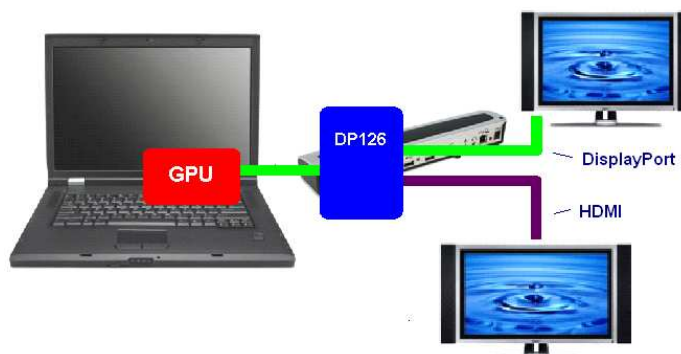

目录

|      |   |    |      |  |    |
|------|---|----|------|--|----|
| 1    | 特性 .....  | 1  | 7.15 | Typical Characteristics .....                                | 17 |
| 2    | 应用 .....  | 1  | 8    | <b>Detailed Description</b> .....                            | 19 |
| 3    | 说明 .....  | 1  | 8.1  | Overview .....   | 19 |
| 4    | 修订历史记录 .....  | 2  | 8.2  | Functional Block Diagram .....                               | 19 |
| 5    | 说明 (续) .....  | 3  | 8.3  | Feature Description .....                                    | 20 |
| 6    | <b>Pin Configuration and Functions</b> .....                  | 3  | 8.4  | Device Functional Modes .....                                | 26 |
| 7    | <b>Specifications</b> .....                                   | 6  | 8.5  | Register Maps .....  | 28 |
| 7.1  | Absolute Maximum Ratings .....                                | 6  | 9    | <b>Application and Implementation</b> .....                  | 36 |
| 7.2  | ESD Ratings .....   | 6  | 9.1  | Application Information .....                                | 36 |
| 7.3  | Recommended Operating Conditions .....                        | 7  | 9.2  | Typical Application .....                                    | 36 |
| 7.4  | Thermal Information .....                                     | 8  | 10   | <b>Power Supply Recommendations</b> .....                    | 40 |
| 7.5  | Power Supply Electrical Characteristics .....                 | 8  | 10.1 | Analog vs Digital vs High Power .....                        | 40 |
| 7.6  | Main Link Input Electrical Characteristics .....              | 9  | 10.2 | Analog Power-Supply Pins and Analog Reference Voltages ..... | 40 |
| 7.7  | DisplayPort Main Link Output Electrical Characteristics ..... | 9  | 11   | <b>Layout</b> .....  | 40 |
| 7.8  | HDMI/DVI Main Link Output Electrical Characteristics .....    | 10 | 11.1 | Layout Guidelines .....                                      | 40 |
| 7.9  | HPD/CAD/EN Electrical Characteristics .....                   | 10 | 11.2 | Layout Example .....   | 43 |
| 7.10 | AUX/DDC/I <sup>2</sup> C Electrical Characteristics .....     | 11 | 12   | <b>器件和文档支持</b> .....   | 45 |
| 7.11 | DisplayPort Main Link Output Switching Characteristics .....  | 11 | 12.1 | 社区资源 .....   | 45 |
| 7.12 | HDMI/DVI Main Link Switching Characteristics .....            | 12 | 12.2 | 商标 .....   | 45 |
| 7.13 | HPD/CAD Switching Characteristics .....                       | 12 | 12.3 | 静电放电警告 .....   | 45 |
| 7.14 | AUX/DDC/I <sup>2</sup> C Switching Characteristics .....      | 12 | 12.4 | Glossary .....   | 45 |
|      |   |    | 13   | <b>机械、封装和可订购信息</b> .....                                     | 45 |

4 修订历史记录

注：之前版本的页码可能与当前版本有所不同。

| Changes from Revision A (March 2012) to Revision B   | Page |
|--|------|
| • 已添加 引脚配置和功能部分, ESD 额定值表, 特性 描述 部分, 器件功能模式, 应用和 实施部分, 电源相关建议部分, 布局部分, 器件和文档支持部分以及机械、封装和可订购信息部分 .....        | 1    |
| • Changed the location of the illustrations within the Elec Spec section to the very end of the tables. .... | 11   |

| Changes from Original (February 2012) to Revision A | Page |
|---|------|
| • 已将器件状态从“产品预览”更改为“量产数据” .....                      | 1    |

## 5 说明 (续)

SN75DP126 提供了连接至显示端口 AUX 接收端通道和 HDMI DDC 接收端通道的独立 AUX 和 DDC 源接口，可无缝连接至包含独立 DDC 和 AUX 接口的图形处理器以及组合有 DDC/AUX 的 GPU。其它诸如热插拔检测 (HPD) 的边频带电路进行了优化以减少到英特尔、AMD、和 NVIDIA 图形处理器无缝连接所需的外部组件数量。

SN75DP126 针对移动应用进行了优化，在 DP++ 主链路输入端配有一个活动检测电路，当不存在有效输入信号时会切换至低功耗输出禁用模式。还支持其它低功耗模式，其中包括一个典型耗散为大约 2mW 的待机模式，当没有检测到连接的视频接收（例如，监视器）的时候进入此模式。

此器件特有一个介于 0°C 至 85°C 之间的扩展运行温度范围。

在 SN75DP126 HDMI/DVI 输出端上，可配置差分输出电压摆幅和预加重电平。SN75DP126 输出信号调节和均衡 (EQ) 参数可通过 I<sup>2</sup>C 接口、VSadj 终端、和 I2C\_CTL\_EN 终端进行编程。HDMI/DVI 接收端 TMDS 输出转换率由源 (SRC) 控制输入控制。

## 6 Pin Configuration and Functions

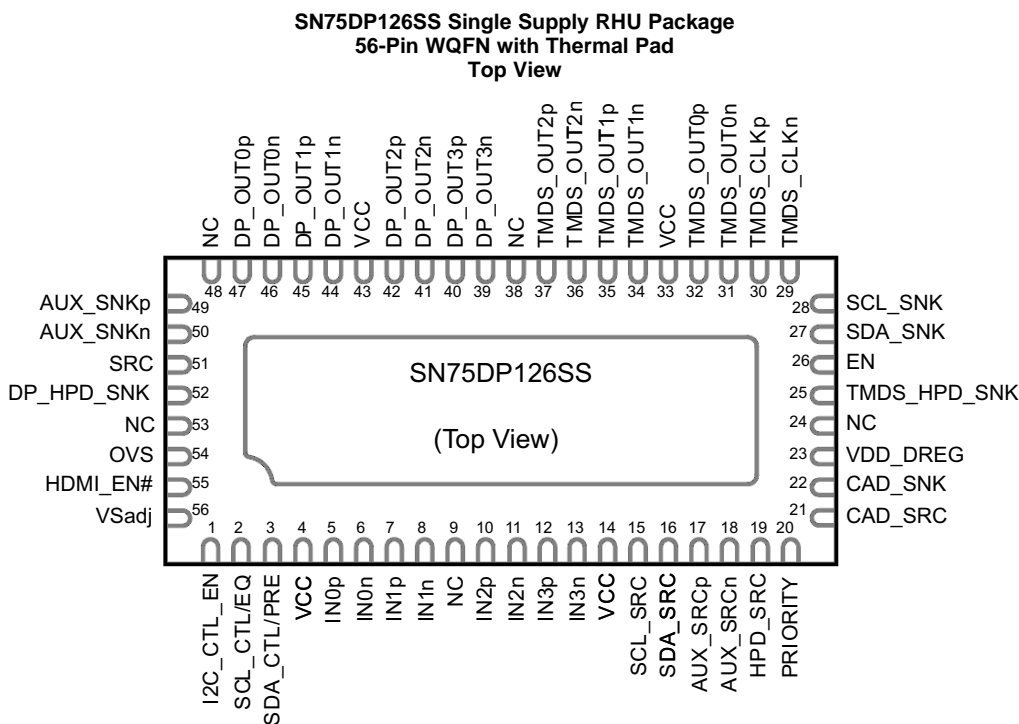

**SN75DP126DS Dual Supply RHU Package  
56-Pin WQFN with Thermal Pad  
Top View**

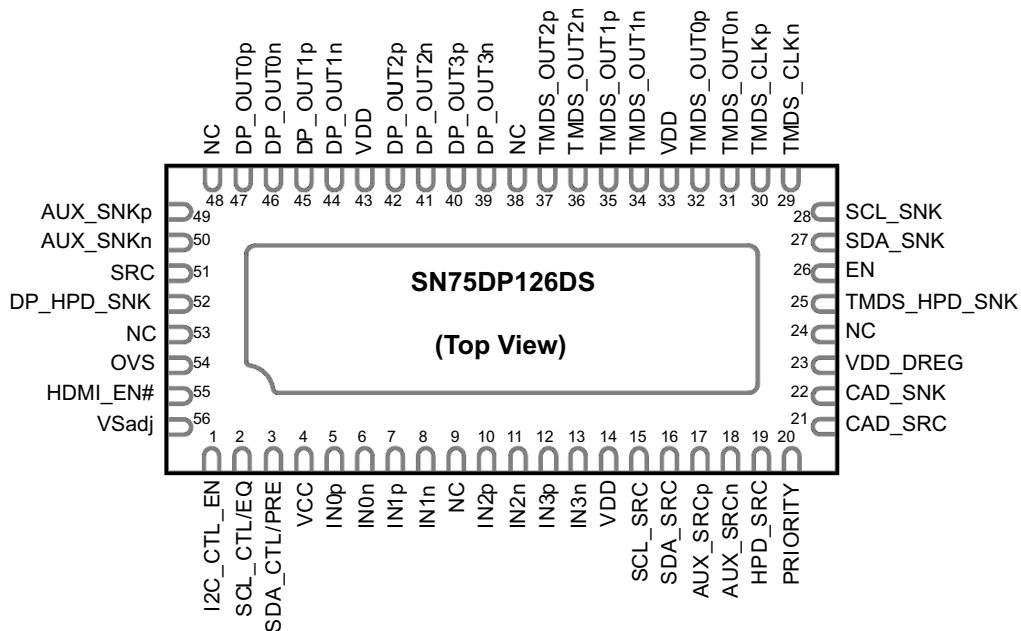

**Pin Functions**

| PIN   |        | I/O  | DESCRIPTION                                      |
|---|--------|--|--|
| SIGNAL  | NO.    |  |  |
| <b>DISPLAYPORT AND HDMI MAIN LINK TERMINALS</b> |        |  |  |
| IN0p, IN0n                                      | 5, 6   | 100Ω<br>Differential<br>Input                | DisplayPort Main Link Lane 0 Differential Input  |
| IN1p, IN1n                                      | 7, 8   |  | DisplayPort Main Link Lane 1 Differential Input  |
| IN2p, IN2n                                      | 10, 11 |  | DisplayPort Main Link Lane 2 Differential Input  |
| IN3p, IN3n                                      | 12, 13 |  | DisplayPort Main Link Lane 3 Differential Input  |
| DP_OUT0p,<br>DP_OUT0n                           | 47, 46 | 100Ω<br>Differential<br>Output               | DisplayPort Main Link Lane 0 Differential Output |
| DP_OUT1p,<br>DP_OUT1n                           | 45, 44 |  | DisplayPort Main Link Lane 1 Differential Output |
| DP_OUT2p,<br>DP_OUT2n                           | 42, 41 |  | DisplayPort Main Link Lane 2 Differential Output |
| DP_OUT3p,<br>DP_OUT3n                           | 40, 39 |  | DisplayPort Main Link Lane 3 Differential Output |
| TMDS_CLKp,<br>TMDS_CLKn                         | 30, 29 | 100Ω<br>Differential<br>Output<br>(Failsafe) | HDMI/DVI Clock TMDS Differential Output          |
| TMDS_OUT0p,<br>TMDS_OUT0n                       | 32, 31 |  | HDMI/DVI Data Lane 0 TMDS Differential Output    |
| TMDS_OUT1p,<br>TMDS_OUT1n                       | 35, 34 |  | HDMI/DVI Data Lane 1 TMDS Differential Output    |
| TMDS_OUT2p,<br>TMDS_OUT2n                       | 37, 36 |  | HDMI/DVI Data Lane 2 TMDS Differential Output    |

### Pin Functions (continued)

| PIN                                       |        | I/O                         | DESCRIPTION   |
|---|--------|-----------------------------|---|
| SIGNAL                                    | NO.    |                             |   |
| <b>AUX CHANNEL AND DDC DATA TERMINALS</b> |        |                             |   |
| AUX_SRCp,<br>AUX_SRCn                     | 17, 18 | I/O<br>(Failsafe)           | Source Side Bidirectional DisplayPort Auxiliary Data Channel. These signals are connected to the AUX_SNK channel when the DisplayPort sink is selected; AC coupling should be implemented.  |
| AUX_SNKp,<br>AUX_SNKn                     | 49, 50 |                             | Sink Side Bidirectional DisplayPort Auxiliary Data Channel.   |
| SCL_SRC,<br>SDA_SRC                       | 15, 16 |                             | Source Side Bidirectional I <sup>2</sup> C Display Data Channel (DDC) for TMDS modes. These terminals include integrated 60 kΩ pull-up resistors.   |
| SCL_SNK,<br>SDA_SNK                       | 28, 27 |                             | HDMI/DVI Sink Side Bidirectional I <sup>2</sup> C Display Data Channel (DDC).   |
| <b>HOT PLUG DETECT AND CAD TERMINALS</b>  |        |                             |   |
| HPD_SRC                                   | 19     | Output                      | Hot Plug Detect Output to the Source.<br>This output shall be driven high when the source shall be connected to either the HDMI/DVI sink or the DisplayPort sink, and driven low when no sink is selected. This output will be asserted for a fixed period of time during active (PRIORITY based) transition from one sink to the other.  |
| CAD_SRC                                   | 21     |                             | Source Side Cable Adapter Detect Output. When the DisplayPort sink is selected, this output represents the condition of the CAD_SNK input, active high as default; polarity may be programmed through the local I <sup>2</sup> C interface. When the HDMI/DVI sink is selected, this output is driven high.   |
| DP_HPD_SNK                                | 52     | Input<br>(Failsafe)         | DisplayPort Hot Plug Detect Input from Sink. This device input is 5-V tolerant, and includes an integrated 130 kΩ pull-down resistor.<br><i>Note: pull this input high during compliance testing or use I<sup>2</sup>C control interface to go into compliance test mode and control DP_HPD_SNK and HPD_SRC by software.</i>  |
| TMDS_HPD_SNK                              | 25     |                             | HDMI/DVI Hot Plug Detect Input from Sink. This device input is 5-V tolerant, and includes an integrated 130 kΩ pull-down resistor.  |
| CAD_SNK                                   | 22     | Input                       | DisplayPort Cable Adapter Detect Input. An external 1MΩ resistor to GND is recommended. This terminal is used to select DP mode (low input) or TMDS mode (high input) when the DisplayPort sink is selected.  |
| <b>CONTROL TERMINALS</b>                  |        |                             |   |
| VSadj                                     | 56     | Input                       | HDMI/DVI Sink Differential Voltage Swing Control. An external resistor connecting this pin to GND determines the output voltage swing. A value of 4.7 kΩ is recommended to provide a typical swing of 1000 mV. VSadj resistor values of 4.7 kΩ ± 1 kΩ control the output voltage swing in a near-linear function of approximately 2 mV/100 Ω.<br><i>Note: this input does not impact the output when a DisplayPort sink is selected and operating in TMDS mode (as supported by the DP++ source)</i>  |
| HDMI_EN#                                  | 55     |                             | HDMI/DVI Sink Type Control. When this input is low, the output is HDMI 1.4b compliant when the HDMI/DVI sink is selected. When this input is high, the output is DVI 1.0 compliant when the HDMI/DVI sink is selected.  |
| PRIORITY                                  | 20     |                             | Output Select Priority. Selects the priority for the output in the case both DP_HPD_SNK and TMDS_HPD_SNK are high indicating two sinks are connected. When low, the DisplayPort sink has priority selection. When high, the HDMI/DVI sink has priority.<br><i>Note: An external RC circuit should be connected to the PRIORITY pin to insure that the SN75DP126 functions properly with some non-compliant monitors. See the SN75DP126 Reference Schematics for more information.</i>   |
| SRC                                       | 51     | 3-Level Input               | TMDS Slew Rate Control. When the HDMI/DVI sink is selected, the slew rate is controlled by the HDMI_EN# input and by the SRC control input:<br>V <sub>IL</sub> = TMDS rise and fall times meet t <sub>T1</sub> specifications<br>V <sub>IM</sub> (between V <sub>IL</sub> and V <sub>IH</sub> ) = TMDS rise and fall times meet t <sub>T2</sub> specifications (Recommended setting)<br>V <sub>IH</sub> = TMDS rise and fall times meet t <sub>T3</sub> specifications<br><i>Note: this input does not impact the output when a DisplayPort sink is selected and operating in TMDS mode (as supported by the DP++ source)</i> |
| OVS                                       | 54     | 3-Level Input               | Source Side DDC Input/Output Buffer Control Input. When the HDMI/DVI sink is selected, the DDC V <sub>OL</sub> and V <sub>IL</sub> is controlled by the OVS control input:<br>V <sub>IL</sub> = Source DDC interface meets V <sub>OL(3)</sub> and V <sub>IL(3)</sub> specifications<br>V <sub>IM</sub> (between V <sub>IL</sub> and V <sub>IH</sub> ) = Source DDC interface meets V <sub>OL(2)</sub> and V <sub>IL(2)</sub> specifications<br>V <sub>IH</sub> = Source DDC interface meets V <sub>OL(1)</sub> and V <sub>IL(1)</sub> specifications  |
| I2C_CTL_EN                                | 1      | 3-Level Input               | Local I <sup>2</sup> C Interface Enable Control and Target Address Select. When low, the local I <sup>2</sup> C interface is disabled; when input is between V <sub>IL</sub> and V <sub>IH</sub> levels, the local I <sup>2</sup> C interface is enabled and is addressed at 0x58h (Write) and 0x59h (Read); when input is high, the local I <sup>2</sup> C interface is enabled and is addressed at 0x5Ah (Write) and 0x5Bh (Read).  |
| SCL_CTL/EQ                                | 2      | 3-Level Input<br>(Failsafe) | Local I <sup>2</sup> C Interface Clock, or Equalizer Setting Control Input. When I2C_CTL_EN is input high or floating, this terminal is the local I <sup>2</sup> C interface clock used to configure SN75DP126.<br>When I2C_CTL_EN is low, this terminal can be used to configure the input EQ.   |

**Pin Functions (continued)**

| PIN                                |                              | I/O                                   | DESCRIPTION   |
|------------------------------------|------------------------------|---------------------------------------|---|
| SIGNAL                             | NO.                          |                                       |   |
| SDA_CTL/PRE                        | 3                            | I/O<br>3-Level<br>Input<br>(Failsafe) | Local I <sup>2</sup> C Interface Data, or TMDS Pre-emphasis Control Input. When I2C_CTL_EN is input high or floating, this terminal is the local I <sup>2</sup> C interface data signal.<br>When I2C_CTL_EN is low, this terminal configures the HDMI/DVI sink TMDS output pre-emphasis as:<br>$V_{IL} = 0$ dB pre-emphasis applied to TMDS output<br>$V_{IM} =$ Not Recommended<br>$V_{IH} = 2$ dB pre-emphasis applied to TMDS output<br>When 2 dB pre-emphasis is enabled, the steady state TMDS output swing is reduced from that selected by VSadj, and the transition time is reduced from that selected by SRC.<br><i>Note: this input does not impact the output when a DisplayPort sink is selected and operating in TMDS mode (as supported by the DP++ source), whereas no pre-emphasis is applied to the output signal in this condition.</i> |
| EN                                 | 26                           | Low-Voltage<br>Input<br>(Failsafe)    | Device Enable / Reset (Power Down). This input incorporates internal pullup of 150 k $\Omega$ , and only 1.2-V tolerant (the high level shall be limited to 1.2 V).<br>When high, the device is enabled for normal operation.<br>When low, the device is in power down mode; all outputs excluding HPD_SRC and CAD_SRC are high-impedance, and inputs excluding DP_HPD_SNK, TMDS_HPD_SNK, and CAD_SNK are ignored; all local I <sup>2</sup> C and DPCD registers are reset to their default values when this input is low.<br>At power up, the EN input must not be de-asserted until the V <sub>CC</sub> supply has reached at least the minimum recommended supply voltage level.   |
| <b>SUPPLY AND GROUND TERMINALS</b> |                              |                                       |   |
| V <sub>CC</sub>                    | SN75DP126SS<br>4, 14, 33, 43 | 3.3-V Supply                          |   |
|                                    | SN75DP126DS<br>4             |                                       |   |
| V <sub>DD</sub>                    | SN75DP126DS<br>14, 33, 43    | 1.05-V Supply                         |   |
| V <sub>DD_DREG</sub>               | 23                           |                                       | SN75DP126SS: Digital voltage regulator decoupling; install 1 $\mu$ F to GND.<br>SN75DP126DS: Treat same as V <sub>DD</sub> ; this pin will be most noisy of all V <sub>DD</sub> terminals and needs a de-coupling capacitor nearby.   |
| GND                                | Exposed Thermal Pad          |                                       | Ground. Reference GND connection shall be made to the exposed thermal pad.  |
| NC                                 | 9, 53, 38, 48, 24            |                                       | No connect. These terminals may be left unconnected, or connect to GND.   |

## 7 Specifications

### 7.1 Absolute Maximum Ratings

 over operating free-air temperature range (unless otherwise noted)<sup>(1)</sup>

|                      |  | MIN  | MAX | UNIT |
|----------------------|--|------|-----|------|
| Supply voltage range | V <sub>CC</sub>                            | -0.3 | 4   | V    |
|                      | V <sub>DD</sub> , V <sub>DD_DREG</sub>     | -0.3 | 1.3 | V    |
| Voltage range        | Main Link I/O Differential Voltage         | -0.3 | 1.4 | V    |
|                      | DP_HPD_SNK, TMDS_HPD_SNK, SCL_SNK, SDA_SNK | -0.3 | 5.5 | V    |
|                      | EN   | -0.3 | 1.3 | V    |
|                      | All other terminals                        | -0.3 | 4   | V    |
| T <sub>stg</sub>     | Storage temperature                        | -55  | 150 | °C   |

(1) Stresses beyond those listed under *Absolute Maximum Ratings* may cause permanent damage to the device. These are stress ratings only, which do not imply functional operation of the device at these or any other conditions beyond those indicated under *Recommended Operating Conditions*. Exposure to absolute-maximum-rated conditions for extended periods may affect device reliability.

### 7.2 ESD Ratings

|                    |                         | VALUE  | UNIT  |
|--------------------|-------------------------|--|-------|
| V <sub>(ESD)</sub> | Electrostatic discharge | Human body model (HBM), per ANSI/ESDA/JEDEC JS-001 <sup>(1)</sup>              | ±2000 |
|                    |                         | Charged-device model (CDM), per JEDEC specification JESD22-C101 <sup>(2)</sup> | ±1000 |

(1) JEDEC document JEP155 states that 500-V HBM allows safe manufacturing with a standard ESD control process.

(2) JEDEC document JEP157 states that 250-V CDM allows safe manufacturing with a standard ESD control process.

### 7.3 Recommended Operating Conditions

over operating free-air temperature range (unless otherwise noted)

|   |  | MIN  | NOM  | MAX                    | UNIT             |   |
|---|--|--|------|------------------------|------------------|---|
| V <sub>CC</sub>   | Supply voltage   | 3  | 3.3  | 3.6                    | V                |   |
| V <sub>DD</sub>   | Digital core and Main Link supply voltage  | 1.0  | 1.05 | 1.2                    | V                |   |
| T <sub>A</sub>  | Operating free-air temperature   | 0  |      | 85                     | °C               |   |
| T <sub>S</sub>  | Storage temperature  | -65  |      | 150                    | °C               |   |
| T <sub>CASE</sub>                                       | Case temperature   |  | 97.1 |                        | °C               |   |
| <b>DP++ MAIN LINK TERMINALS</b>                         |  |  |      |                        |                  |   |
| V <sub>ID</sub>   | Peak-to-peak input differential voltage; RBR, HBR, HBR2                            | 0.3  |      | 1.40                   | V <sub>pp</sub>  |   |
| d <sub>R(DP)</sub>                                      | Data rate; DisplayPort sink  |  | 5.4  |                        | Gbps             |   |
| d <sub>R(HDMI)</sub>                                    | Data rate; HDMI sink   |  | 3.4  |                        | Gbps             |   |
| C <sub>AC</sub>   | AC coupling capacitance (each DP input and each DP output line)                    | 75   |      | 200                    | nF               |   |
| R <sub>tdiff</sub>                                      | Differential output termination resistance; DisplayPort sink and HDMI sink         | 80   | 100  | 120                    | Ω                |   |
| V <sub>Oterm</sub>                                      | Output termination voltage (AC coupled)  | 0  |      | 2                      | V                |   |
| t <sub>SK(HBR2)</sub>                                   | Intra-pair skew at the input at 5.4 Gbps   |  | 20   |                        | ps               |   |
| t <sub>SK(HBR)</sub>                                    | Intra-pair skew at the input at 2.7 Gbps   |  | 100  |                        | ps               |   |
| t <sub>SK(RBR)</sub>                                    | Intra-pair skew at the input at 1.62 Gbps  |  | 300  |                        | ps               |   |
| <b>AUX CHANNEL DATA TERMINALS</b>                       |  |  |      |                        |                  |   |
| V <sub>I-DC</sub>                                       | DC Input Voltage, AUX_SRCp/n and AUX_SNKp/n (DP and TMDS modes)                    | -0.5   |      | 3.6                    | V                |   |
| V <sub>ID</sub>   | Differential input voltage amplitude (DP mode only)                                | 300  |      | 1400                   | mV <sub>PP</sub> |   |
| d <sub>R(AUX)</sub>                                     | Data rate (before Manchester encoding)   | 0.8  | 1    | 1.2                    | Mbps             |   |
| d <sub>R(AUX)</sub>                                     | Data rate Fast AUX (300ppm frequency tolerance)                                    |  | 720  |                        | Mbps             |   |
| t <sub>jccin_adj</sub>                                  | Cycle-to-cycle AUX input jitter adjacent cycle (DP mode only)                      |  |      | 0.05                   | UI               |   |
| t <sub>jccin</sub>                                      | Cycle-to-cycle AUX input jitter within one cycle (DP mode only)                    |  |      | 0.1                    | UI               |   |
| C <sub>AC</sub>   | AUX AC coupling capacitance  | 75   |      | 200                    | nF               |   |
| <b>DDC, LOCAL I<sup>2</sup>C, AND CONTROL TERMINALS</b> |  |  |      |                        |                  |   |
| V <sub>I-DC</sub>                                       | DC Input Voltage   | DP_HPD_SNK, TMDS_HPD_SNK, SCL/SDA_SNK                        |      | -0.3                   | 5.5              | V |
|   |  | All other DDC, local I <sup>2</sup> C, and control terminals |      | -0.3                   | 3.6              |   |
| V <sub>IH</sub>   | High-level input voltage   | SCL/SDA_SRC  |      | 2.1                    |                  | V |
|   |  | All other DDC, Local I <sup>2</sup> C, and control terminals |      | V <sub>CC</sub> -0.5   |                  |   |
| V <sub>IL</sub>   | Low-level input voltage <sup>(1)</sup>   |  | 0.5  |                        | V                |   |
| V <sub>IM</sub>   | Mid-level input voltage <sup>(2)</sup>   | V <sub>CC</sub> /2-0.3                                       |      | V <sub>CC</sub> /2+0.3 |                  |   |
| d <sub>R</sub>  | Data rate  |  | 100  |                        | kbps             |   |
| V <sub>TH(EN)</sub>                                     | EN input threshold voltage   | 280  |      | 800                    | mV               |   |
| f <sub>SCL</sub>  | SCL clock frequency standard I <sup>2</sup> C mode                                 |  | 100  |                        | kHz              |   |
| t <sub>w(L)</sub>                                       | SCL clock low period standard I <sup>2</sup> C mode                                | 4.7  |      |                        | μs               |   |
| t <sub>w(H)</sub>                                       | SCL clock high period standard I <sup>2</sup> C mode                               | 4.0  |      |                        | μs               |   |
| C <sub>bus</sub>  | Total capacitive load for each bus line (DDC and local I <sup>2</sup> C terminals) |  | 400  |                        | pF               |   |

(1) V<sub>IL</sub> for SCL\_SRC and SDA\_SRC are listed in the AUX/DDC/I<sup>2</sup>C Electrical Characteristics Table.

(2) V<sub>IM</sub> is only applicable for 3-Level control pins.



## 7.4 Thermal Information

| THERMAL METRIC <sup>(1)</sup> |  | SN75DP126  |      |
|-------------------------------|--|------------|------|
|                               |  | RHU (WQFN) |      |
|                               |  | 56 PINS    |      |
| Symbol                        | Description                                  | Value      | Unit |
| $R_{\theta JA}$               | Junction-to-ambient thermal resistance       | 35         | °C/W |
| $R_{\theta JC(top)}$          | Junction-to-case (top) thermal resistance    | 25         | °C/W |
| $R_{\theta JB}$               | Junction-to-board thermal resistance         | 15         | °C/W |
| $\Psi_{JT}$                   | Junction-to-top characterization parameter   | 2          | °C/W |
| $\Psi_{JB}$                   | Junction-to-board characterization parameter | 10         | °C/W |
| $R_{\theta JC(bot)}$          | Junction-to-case (bottom) thermal resistance | 8          | °C/W |

(1) For more information about traditional and new thermal metrics, see the *Semiconductor and IC Package Thermal Metrics* application report, [SPRA953](#).

## 7.5 Power Supply Electrical Characteristics

over recommended operating conditions (unless otherwise noted)

| PARAMETER <sup>(1)</sup> |                                       | TEST CONDITIONS  | MIN | TYP  | MAX  | UNIT |
|--------------------------|---------------------------------------|--|-----|------|------|------|
| $I_{CC}$                 | Device current under normal operation | 4 DP Lanes; DP Sink<br>Maximum Conditions: DP at 5.4-Gbps PRBS, $V_{OD} = 510$ mV <sub>pp</sub> ,<br>PRE = 6 dB; AUX at 1-Mbps PRBS, $V_{ID} = 1000$ mVpp; EQ = 6 dB<br>Typical Conditions: DP at 5.4-Gbps PRBS, $V_{OD} = 510$ mVpp,<br>PRE = 0 dB AUX and I <sup>2</sup> C Idle; EQ = 3 dB |     | 138  | 242  | mA   |
|                          |                                       | 2 DP Lanes; DP Sink<br>Maximum Conditions: DP at 5.4-Gbps PRBS, $V_{OD} = 510$ mVpp,<br>PRE = 6 dB; AUX at 1-Mbps PRBS, $V_{ID} = 1000$ mVpp; EQ = 6 dB<br>Typical Conditions: DP at 5.4-Gbps PRBS, $V_{OD} = 510$ mVpp,<br>PRE = 0 dB AUX and I <sup>2</sup> C Idle; EQ = 3 dB              |     | 73   | 125  | mA   |
|                          |                                       | 1 DP Lanes; DP Sink<br>Maximum Conditions: DP at 5.4-Gbps PRBS, $V_{OD} = 510$ mVpp,<br>PRE = 6 dB; AUX at 1-Mbps PRBS, $V_{ID} = 1000$ mVpp; EQ = 6 dB<br>Typical Conditions: DP at 5.4-Gbps PRBS, $V_{OD} = 510$ mVpp,<br>PRE = 0 dB AUX and I <sup>2</sup> C Idle; EQ = 3 dB              |     | 42   | 70   | mA   |
|                          |                                       | 4 DP Lanes; HDMI Sink<br>Maximum Conditions: TMDS at 3.4 Gbps, $V_{OD} = 1200$ mVpp,<br>$V_{ID} = 1000$ mVpp<br>Typical Conditions: TMDS at 3.4 Gbps, $V_{OD} = 1000$ mVpp,<br>DDC and I <sup>2</sup> C Idle   |     | 130  | 160  | mA   |
| $I_{SD}$                 | Shutdown mode current                 | 4 DP Lanes   |     | 0.55 | 4.00 | mA   |
| $I_{SBY}$                | Standby mode current                  | 4 DP Lanes.  |     | 0.85 | 4.00 | mA   |
| $I_{D3}$                 | D3 power down mode current            | 4 DP Lanes.  |     | 10   | 15   | mA   |
| $I_{OD}$                 | Output disable (squelch) mode current | 4 DP Lanes.  |     | 53   | 75   | mA   |

(1) Values are  $V_{CC}$  supply measurements for SN75DP126SS and  $V_{DD}$  supply measurements for the SN75DP126DS; the maximum  $V_{CC}$  supply measurement for the SN75DP126DS is 8 mA during normal operation and 0.5 mA during shutdown, standby, and D3 power down modes.



## 7.6 Main Link Input Electrical Characteristics

over recommended operating conditions (unless otherwise noted)

| PARAMETER         |   | TEST CONDITIONS  | MIN | TYP | MAX | UNIT             |
|-------------------|---|--|-----|-----|-----|------------------|
| $A_{EQ(HBR)}$     | Equalizer gain for RBR/HBR                          | See Table 4 for EQ setting details; Max value represents the typical value for the maximum configurable EQ setting |     |     | 9   | dB               |
| $A_{EQ(HBR2)}$    | Equalizer gain for HBR2                             |  |     |     | 18  | dB               |
| $A_{EQ(TMDS\_D)}$ | Equalizer gain for DP sink in TMDS mode; data lanes |  |     |     | 9   | dB               |
| $A_{EQ(TMDS\_C)}$ | Equalizer gain for DP sink in TMDS mode; clock lane |  |     |     | 3   | dB               |
| $A_{EQ(HDMI\_D)}$ | EQ gain, HDMI sink; data lanes                      |  |     |     | 9   | dB               |
| $A_{EQ(HDMI\_C)}$ | EQ gain, HDMI sink; clock lane                      |  |     |     | 3   | dB               |
| RIN               | Input termination impedance                         |  | 40  | 50  | 60  | $\Omega$         |
| Vterm             | Input termination voltage                           | AC coupled; self-biased  | 0   |     | 2   | V                |
| $V_{SQUELCH}$     | Squelch threshold voltage                           | SQUELCH_SENSITIVITY = 00   |     | 60  |     | mV <sub>PP</sub> |
|                   |   | SQUELCH_SENSITIVITY = 01 (default)   |     | 115 |     |                  |
|                   |   | SQUELCH_SENSITIVITY = 10   |     | 160 |     |                  |
|                   |   | SQUELCH_SENSITIVITY = 11   |     | 200 |     |                  |

## 7.7 DisplayPort Main Link Output Electrical Characteristics

over recommended operating conditions (unless otherwise noted)

| PARAMETER              |  | TEST CONDITIONS  | MIN                                     | TYP  | MAX  | UNIT              |
|------------------------|--|--|---|------|------|-------------------|
| $V_{OD(L0)}$           | Output Differential Voltage Swing              | $V_{PRE(L0)}$ ; 675 Mbps D10.2 Test Pattern; BOOST = 01; 100- $\Omega$ $R_{tdiff}$ Termination | 238                                     | 340  | 442  | mV <sub>PP</sub>  |
| $V_{OD(L1)}$           |  |  | 357                                     | 510  | 663  |                   |
| $V_{OD(L2)}$           |  |  | 484                                     | 690  | 897  |                   |
| $V_{OD(L3)}$           |  |  | 700                                     | 1000 | 1300 |                   |
| $V_{OD(TMDS)}$         |  |  | 675 Mbps D10.2 Test Pattern; BOOST = 01 | 420  | 600  |                   |
| $\Delta V_{OD(L0L1)}$  | Output Peak-to-Peak Differential Voltage Delta | $\Delta V_{ODn} = 20 \times \log(V_{ODL(n+1)} / V_{ODL(n)})$<br>Per PHY_CTS section 3.2 at TP2 | 1.7                                     | 3.5  | 5.3  | dB                |
| $\Delta V_{OD(L1L2)}$  |  |  | 1.6                                     | 2.5  | 3.5  |                   |
| $\Delta V_{OD(L2L3)}$  |  |  | 0.8                                     | 3.5  | 6.0  |                   |
| $V_{PRE(L0)}$          | Driver output pre-emphasis                     | All $V_{OD}$ options; Any BOOST setting  |   | 0    | 0.25 | dB                |
| $V_{PRE(L1)}$          |  | $V_{OD} = V_{OD(L0)}$ , $V_{OD(L1)}$ , or $V_{OD(L2)}$ ; BOOST = 01                            |   | 3.5  |      |                   |
| $V_{PRE(L2)}$          |  | $V_{OD} = V_{OD(L0)}$ or $V_{OD(L1)}$ ; BOOST = 01   |   | 6.0  |      |                   |
| $V_{PRE(L3)}$          |  | $V_{OD} = V_{OD(L0)}$ ; BOOST = 01   |   | 9.5  |      |                   |
| $V_{PRE(BOOST)}$       | Output $V_{PRE}$ Boost                         | BOOST = 10   |   | +15  |      | %dB               |
|                        |  | BOOST = 00   |   | -15  |      |                   |
| $\Delta V_{PRE(L1L0)}$ | Pre-emphasis Delta                             | Per PHY_CTS section 3.3 at TP2   | 2.0                                     |      |      | dB                |
| $\Delta V_{PRE(L2L1)}$ |  |  | 1.6                                     |      |      |                   |
| $\Delta V_{PRE(L3L2)}$ |  |  | 1.6                                     |      |      |                   |
| $\Delta V_{ConsBit}$   | Non-transition bit voltage variation           | Per PHY_CTS section 3.3.5  |   |      | 30   | %V                |
| $R_{OUT}$              | Driver output impedance                        |  | 40                                      | 50   | 60   | $\Omega$          |
| $V_{OCM(SS)}$          | Steady state output common mode voltage        |  | 0                                       |      | 2    | V                 |
| $V_{OCM(PP)}$          | Output common mode noise                       | Per PHY_CTS section 3.10   |   | 20   |      | mV <sub>RMS</sub> |
|                        |  |  | RBR, HBR                                |      | 30   |                   |
| $I_{OS}$               | Short circuit current limit                    | Main Link outputs shorted to GND   |   |      | 50   | mA                |

## 7.8 HDMI/DVI Main Link Output Electrical Characteristics

over recommended operating conditions (unless otherwise noted)

| PARAMETER            |   | TEST CONDITIONS  | MIN            | TYP  | MAX            | UNIT             |
|----------------------|---|--|----------------|------|----------------|------------------|
| $V_{OH}$             | Single-end high level output voltage  | $V_{Sadj} = 4.7\text{ k}\Omega$                              | $V_{CC} - 10$  |      | $V_{CC} + 10$  | mV               |
| $V_{OL}$             | Single-end low level output voltage   | $V_{Sadj} = 4.7\text{ k}\Omega$                              | $V_{CC} - 600$ |      | $V_{CC} - 400$ | mV               |
| $V_{SWING}$          | Single-end output voltage swing   | $V_{Sadj} = 4.7\text{ k}\Omega$ ; $SDA\_CTL/PRE \leq V_{IL}$ | 400            |      | 600            | mV               |
| $\Delta V_{SWING}$   | Change in single-end output voltage swing per $100\Omega$ $\Delta V_{Sadj}$ |  |                | 20   |                | mV               |
| $V_{OCM(SS)}$        | Steady state output common mode voltage                                     |  | $V_{CC} - 300$ |      | $V_{CC} - 200$ | mV               |
| $\Delta V_{OCM(SS)}$ | Change in steady state output common mode voltage between logic levels      |  | -5             |      | 5              | mV               |
| $V_{OD(PP)}$         | Peak-to-peak output differential voltage                                    | $V_{Sadj} = 4.7\text{ k}\Omega$ ; $SDA\_CTL/PRE \leq V_{IL}$ | 800            |      | 1200           | mV <sub>PP</sub> |
|                      |   | $V_{Sadj} = 4.7\text{ k}\Omega$ ; $SDA\_CTL/PRE \geq V_{IH}$ |                | 640  |                |                  |
| $V_{OD(SS)}$         | Steady state output differential voltage                                    | $V_{Sadj} = 4.7\text{ k}\Omega$ ; $SDA\_CTL/PRE \leq V_{IL}$ |                | 1000 |                | mV <sub>PP</sub> |
|                      |   | $V_{Sadj} = 4.7\text{ k}\Omega$ ; $SDA\_CTL/PRE \geq V_{IH}$ |                | 630  |                |                  |
| $I_{OS}$             | Short circuit current limit   | $V_{ID} = 500\text{ mV}$                                     |                |      | 15             | mA               |

## 7.9 HPD/CAD/EN Electrical Characteristics

over recommended operating conditions (unless otherwise noted)

| PARAMETER    |  | TEST CONDITIONS   | MIN | TYP | MAX   | UNIT          |
|--------------|--|---|-----|-----|-------|---------------|
| $V_{IH}$     | High-level input voltage                                       | HPD_SNK, CAD_SNK  | 2.1 |     |       | V             |
|              |  | EN  | 0.8 |     |       |               |
| $V_{IL}$     | Low-level input voltage  | HPD_SNK, CAD_SNK  |     |     | 1.08  | V             |
|              |  | EN  |     |     | 0.285 |               |
| $V_{OH}$     | High-level output voltage                                      | $I_{OH} = 500\text{ }\mu\text{A}$ ; HPD_SRC, CAD_SRC  | 2.7 |     | 3.6   | V             |
| $V_{OL}$     | Low-level output voltage                                       | $I_{OH} = 500\text{ }\mu\text{A}$ ; HPD_SRC, CAD_SRC  | 0   |     | 0.1   | V             |
| $R_{outCAD}$ | CAD series output resistance (1)                               | DP_HPDP_SNK = CAD_SNK = $V_{CC}$  |     | 150 |       | $\Omega$      |
| $R_{outHPD}$ | HPD series output resistance                                   | DP_HPDP_SNK = TMDS_HPDP_SNK = $V_{CC}$  |     | 150 |       | $\Omega$      |
| $I_{LEAK}$   | Failsafe condition leakage current                             | $V_{CC} = 0\text{ V}$ ; $V(\text{pin}) = 1.2\text{ V}$ ; EN                                     |     |     | 20    | $\mu\text{A}$ |
|              |  | $V_{CC} = 0\text{ V}$ ; $V(\text{pin}) = 3.3\text{ V}$ ; DP_HPDP_SNK, TMDS_HPDP_SNK             |     |     | 40    |               |
| $I_{H\_HPD}$ | High level input current                                       | Device powered; $V_{IH} = 1.9\text{ V}$ ;<br>$I_{H\_HPD}$ includes $R_{pdHPD}$ resistor current |     |     | 30    | $\mu\text{A}$ |
| $I_{H\_CAD}$ |  |   |     |     | 1     |               |
| $I_{L\_HPD}$ | Low level input current  | Device powered; $V_{IL} = 0.8\text{ V}$ ;<br>$I_{L\_HPD}$ includes $R_{pdHPD}$ resistor current |     |     | 30    | $\mu\text{A}$ |
| $I_{L\_CAD}$ |  |   |     |     | 1     |               |
| $R_{pdHPD}$  | HPD input termination to GND;<br>DP_HPDP_SNK and TMDS_HPDP_SNK | $V_{CC} = 0\text{ V}$   | 100 | 130 | 160   | k $\Omega$    |
| $R_{EN}$     | EN terminal pull-up resistor                                   |   | 120 | 150 | 180   | k $\Omega$    |

## 7.10 AUX/DDC/I<sup>2</sup>C Electrical Characteristics

over recommended operating conditions (unless otherwise noted)

| PARAMETER               |   | TEST CONDITIONS  | MIN | TYP | MAX | UNIT |
|-------------------------|---|--|-----|-----|-----|------|
| C <sub>IO</sub>         | I/O capacitance   | V <sub>IO</sub> = 0 V; f(test) = 1 MHz   |     | 10  |     | pF   |
| r <sub>ON</sub>         | On resistance AUX_SRCn to AUX_SNKn in DP mode                       | V <sub>CC</sub> = 3.0 V w/ V <sub>I</sub> = 2.6 V or V <sub>CC</sub> = 3.6 V w/ V <sub>I</sub> = 3.4 V; I <sub>O</sub> = 5 mA                                    |     |     | 10  | Ω    |
|                         | On resistance AUX_SRCp to AUX_SNKp in DP mode                       | V <sub>CC</sub> = 3.0 V w/ V <sub>I</sub> = 0.3 V or V <sub>CC</sub> = 3.6 V w/ V <sub>I</sub> = 0.4 V; I <sub>O</sub> = 500 mA                                  |     |     | 10  | Ω    |
|                         | On resistance SCL/SDA_SRC to AUX_SNK in TMDS mode                   | V <sub>I</sub> = 0.4 V; I <sub>O</sub> = 3 mA  |     |     | 30  | Ω    |
| Δr <sub>ON</sub>        | On resistance variation with input signal voltage change in DP mode | V <sub>CC</sub> = 3.6 V, I <sub>O</sub> = 5 mA, V <sub>I</sub> = 2.6 V to 3.4 V<br>V <sub>CC</sub> = 3.0 V, I <sub>O</sub> = 5 mA, V <sub>I</sub> = 0 V to 0.4 V |     |     | 5   | Ω    |
| V <sub>ID(HYS)</sub>    | Differential input hysteresis                                       | By design (simulation only)  |     | 50  |     | mV   |
| I <sub>LEAK</sub>       | Failsafe condition leakage current                                  | V <sub>CC</sub> = 0 V; V(pin) = 3.3 V; SCL/SDA_SNK   |     |     | 40  | μA   |
|                         |   | V <sub>CC</sub> = 0 V; V(pin) = 3.3 V; AUX_SNK p/n   |     |     | 20  |      |
|                         |   | V <sub>CC</sub> = 0 V; V(pin) = 3.3 V; SCL_CTL/EQ, SDA_CTL/PRE, AUX_SRCp   |     |     | 5   |      |
|                         |   | V <sub>CC</sub> = 0 V; V(pin) = 3.3 V; AUX_SRCn, SCL/SDA_SRC   |     |     | 60  |      |
| I <sub>H_AUX_DD C</sub> | AUX/DDC High level input current                                    | Device powered; V <sub>I</sub> = V <sub>CC</sub>   |     |     | 5   | μA   |
| I <sub>H_I2C</sub>      | I <sup>2</sup> C High level input current                           |  |     |     | 20  |      |
| I <sub>L_AUX</sub>      | AUX Low level input current   |  |     |     | 5   | μA   |
| I <sub>L_I2C</sub>      | I <sup>2</sup> C Low level input current                            | Device powered; V <sub>I</sub> = GND ;<br>I <sub>L_DDCSRC</sub> includes R <sub>DDC</sub> resistor current   |     |     | 40  |      |
| I <sub>L_DDCSRC C</sub> | DDC Low level input current   |  |     |     | 80  |      |
| V <sub>AUX+</sub>       | AUX_SNKp voltage  | Per PHY_CTS section 3.19   | 0   |     | 0.4 | V    |
| V <sub>AUX-</sub>       | AUX_SNKn voltage  | Per PHY_CTS section 3.18   | 2.4 |     | 3.6 | V    |
| S <sub>1122</sub>       | AC coupled AUX line insertion loss                                  | V <sub>ID</sub> = 400 mV, 360 MHz sine wave  |     |     | 3   | dB   |
| R <sub>DDC</sub>        | Switchable pullup resistor on DDC at source side (SCL_DDC, SDA_DDC) | CAD_SNK = V <sub>IH</sub>  | 48  | 60  | 72  | kΩ   |
| V <sub>IL1</sub>        | SCL/SDA_SRC low-level input voltage                                 | OVS ≥ V <sub>IH</sub>  |     |     | 0.4 | V    |
| V <sub>IL2</sub>        |   | OVS at V <sub>IM</sub>   |     |     | 0.4 |      |
| V <sub>IL3</sub>        |   | OVS ≤ V <sub>IL</sub>  |     |     | 0.3 |      |
| V <sub>OL1</sub>        | SCL/SDA_SRC low-level output voltage                                | OVS ≥ V <sub>IH</sub>  | 0.6 |     | 0.7 | V    |
| V <sub>OL2</sub>        |   | OVS at V <sub>IM</sub>   | 0.5 |     | 0.6 |      |
| V <sub>OL3</sub>        |   | OVS ≤ V <sub>IL</sub>  | 0.4 |     | 0.5 |      |
| V <sub>OL4</sub>        | SCL/SDA_SNK and SCL/SDA_CTL low-level output voltage                | I <sub>O</sub> = 3 mA  |     |     | 0.4 | V    |

## 7.11 DisplayPort Main Link Output Switching Characteristics

over recommended operating conditions (unless otherwise noted) [Figure 1](#) and [Figure 2](#)

| PARAMETER             |                                    | TEST CONDITIONS   | MIN | TYP | MAX | UNIT |
|-----------------------|------------------------------------|---|-----|-----|-----|------|
| t <sub>PD</sub>       | Propagation delay time             |   |     | 350 |     | ps   |
| t <sub>SK1</sub>      | Intra-pair output skew             | Signal input skew = 0 ps; dR = 2.7 Gbps, V <sub>PRE</sub> = 0 dB, 800 mVpp, D10.2 clock pattern at device input; see <a href="#">Figure 2</a>                 |     |     | 20  | ps   |
| t <sub>SK2</sub>      | Inter-pair output skew             |   |     |     | 70  | ps   |
| Δt <sub>jitter</sub>  | Total peak to peak residual jitter | V <sub>OD(L0)</sub> ; V <sub>PRE(L0)</sub> ; EQ = 8 dB; clean source; minimum input and output cabling; 1.62 Gbps, 2.7 Gbps, and 5.4-Gbps PRBS7 data pattern. |     |     | 15  | ps   |
| t <sub>sq_enter</sub> | Squelch Entry Time                 | Time from active DP signal turned off to ML output off with noise floor minimized   | 10  |     | 120 | μs   |
| t <sub>sq_exit</sub>  | Squelch Exit Time                  | Time from DP signal on to ML output on  | 0   |     | 1   | μs   |

## 7.12 HDMI/DVI Main Link Switching Characteristics

 over recommended operating conditions (unless otherwise noted) [Figure 3](#), [Figure 4](#), and [Figure 5](#)

| PARAMETER        |  | TEST CONDITIONS   | MIN | TYP  | MAX       | UNIT    |
|------------------|--|---|-----|------|-----------|---------|
| $t_{PLH}$        | Propagation delay time (low to high)                                 |   | 250 |      | 600       | ps      |
| $t_{PHL}$        | Propagation delay time (high to low)                                 |   | 250 |      | 800       | ps      |
| $t_{T1}$         | Transition time (rise and fall time); measured at 20% and 80% levels | SRC $\leq V_{IL}$ ; SDA_CTL/PRE $\leq V_{IL}$ ; 340 MHz         | 75  |      | 140       | ps      |
| $t_{T2}$         |  | SRC at $V_{IM}$ ; SDA_CTL/PRE $\leq V_{IL}$ ; 340 MHz           | 85  |      | 160       |         |
| $t_{T3}$         |  | SRC $\geq V_{IH}$ ; SDA_CTL/PRE $\leq V_{IL}$ ; 340 MHz         | 100 |      | 200       |         |
| $t_{SK1(T)}$     | Intra-pair output skew   |   |     | 0.15 | $t_{bit}$ | ps      |
| $t_{SK2(T)}$     | Inter-pair output skew   |   |     | 30   |           | ps      |
| $\Delta t_{JIT}$ | Total peak to peak residual jitter; clock and data lanes             | SRC at $V_{IM}$ ; $d_R = 3.4$ Gbps; 0 dB $V_{PRE}$ ; EQ = 13 dB |     |      | 30        | ps      |
| $t_{sq\_enter}$  | Squelch Entry Time   | $d_R = 3.4$ Gbps  | 10  |      | 120       | $\mu s$ |
| $t_{sq\_exit}$   | Squelch Exit Time  |   | 0   |      | 1         |         |

## 7.13 HPD/CAD Switching Characteristics

 over recommended operating conditions (unless otherwise noted) [Figure 6](#)

| PARAMETER          |   | TEST CONDITIONS   | MIN | TYP | MAX | UNIT |
|--------------------|---|---|-----|-----|-----|------|
| $t_{PD(HPD)}$      | Propagation delay DP/TMDS_HPD_SNK to HPD_SRC; rising edge and falling edge                  | See <a href="#">Figure 7</a> ; not valid during switching time $t_{S(HPD)}$ |     |     | 120 | ns   |
| $t_{PD(CAD)}$      | Propagation delay CAD_SNK to CAD_SRC; rising edge and falling edge                          | See <a href="#">Figure 10</a>   |     |     | 50  | ns   |
| $t_{SK(HPD\_CAD)}$ | Output skew HPD_SRC to CAD_SRC when HDMI/DVI sink is selected; rising edge and falling edge | See <a href="#">Figure 10</a>   |     |     | 50  | ns   |
| $t_T(HPD1)$        | HPD logic switch time   | See <a href="#">Figure 8</a>  |     | 350 |     | ms   |
| $t_T(HPD2)$        | HPD logic switch pause time   | See <a href="#">Figure 8</a>  |     | 4.1 |     | ms   |
| $t_T(HPD3)$        | HPD logical disconnect timeout  | See <a href="#">Figure 9</a>  |     | 350 |     | ms   |

## 7.14 AUX/DDC/I<sup>2</sup>C Switching Characteristics

over recommended operating conditions (unless otherwise noted)

| PARAMETER  |   | TEST CONDITIONS   | MIN | TYP | MAX | UNIT    |
|--|---|---|-----|-----|-----|---------|
| $t_{sk(AUX)}$  | AUX intra-pair skew                               | $V_{ID} = 400$ mV, see <a href="#">Figure 11</a>                        |     |     | 400 | ps      |
| $t_{PLH(AUX)}$   | AUX propagation delay, low to high                | CAD_SNK $\leq V_{IL}$ ; 1-Mbps pattern; see <a href="#">Figure 12</a>   |     |     | 3   | ns      |
| $t_{PHL(AUX)}$   | AUX propagation delay, high to low                |   |     |     | 3   | ns      |
| $t_{PLH1(DDC)}$  | DDC propagation delay, low to high <sup>(1)</sup> | Source to Sink; CAD_SNK $\geq V_{IH}$ ; 100-kbps pattern;               |     | 360 |     | ns      |
| $t_{PHL1(DDC)}$  | DDC propagation delay, high to low <sup>(1)</sup> | $C_L$ (Sink) = 400 pF; see <a href="#">Figure 13</a>                    |     | 230 |     | ns      |
| $t_{PLH2(DDC)}$  | DDC propagation delay, low to high <sup>(1)</sup> | Sink to Source; CAD_SNK $\geq V_{IH}$ ; 100-kbps pattern;               |     | 250 |     | ns      |
| $t_{PHL2(DDC)}$  | DDC propagation delay, high to low <sup>(1)</sup> | $C_L$ (Source) = 100 pF; see <a href="#">Figure 14</a>                  |     | 200 |     | ns      |
| $t_{PU(AUX)}$  | Main link D3 wakeup time                          | $V_{ID} = 0.1$ V, $V_{ICM} = 2$ V source side (before AC coupling caps) |     |     | 50  | $\mu s$ |
| <b>Local I<sup>2</sup>C</b>  |   |   |     |     |     |         |
| Refer to the I <sup>2</sup> C-Bus Specification, Version 2.1 (January 2000); SN75DP126 meets the switching characteristics for standard mode transfers up to 100 kbps. |   |   |     |     |     |         |

(1) Applies to DDC pass through to DisplayPort sink and the HDMI/DVI sink.

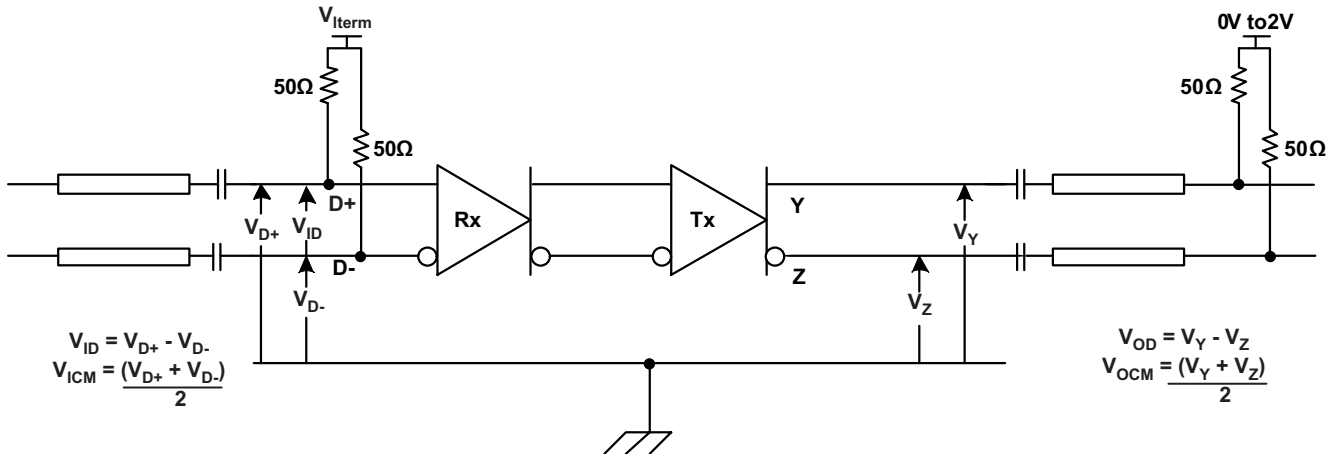

Figure 1. DisplayPort Sink Main Link Test Circuit

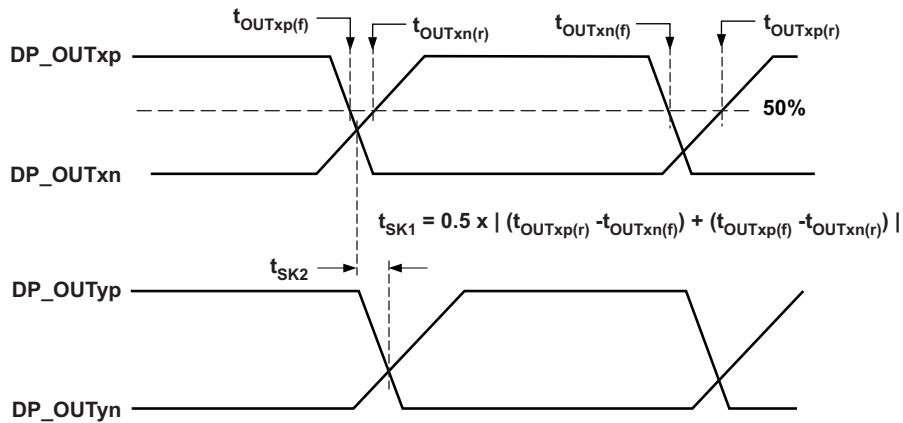

Figure 2. DisplayPort Sink Main Link Skew Measurements

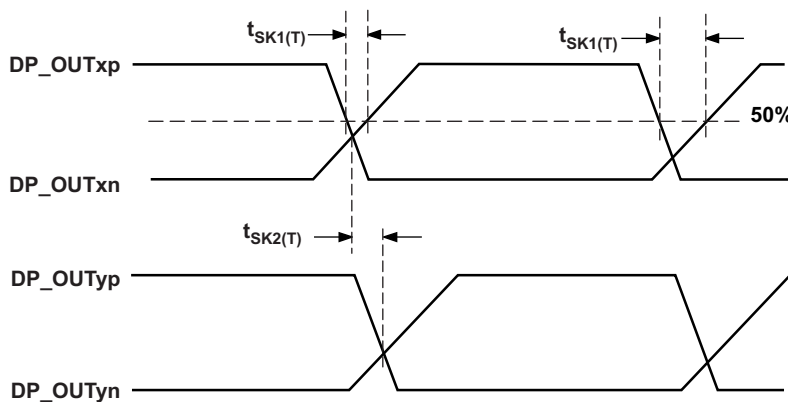

Figure 3. HDMI/DVI Sink TMDS Output Skew Measurements

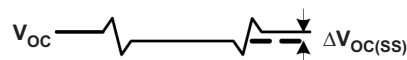
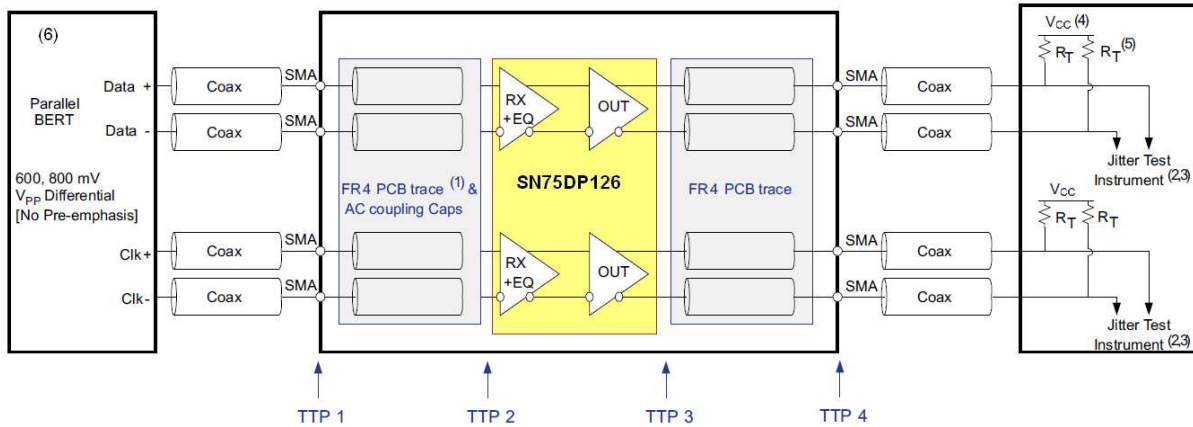

Figure 4. HDMI/DVI TMDS Output Common Mode Measurement



- (1) The FR4 trace between TTP1 and TTP2 is designed to emulate 1-8" of FR4, AC coupling cap and connector. Trace width –4 mils.
- (2) All Jitter is measured at a BER of  $10^{-9}$
- (3) Residual jitter reflects the total jitter measured at TTP4 minus the jitter measured at TTP1
- (4)  $V_{CC} = 3.3\text{ V}$
- (5)  $R_T = 50\Omega$
- (6) The input signal from parallel Bert does not have any pre-emphasis. Refer to recommended operating conditions.

Figure 5. HDMI/DVI TMD5 Output Jitter Measurement

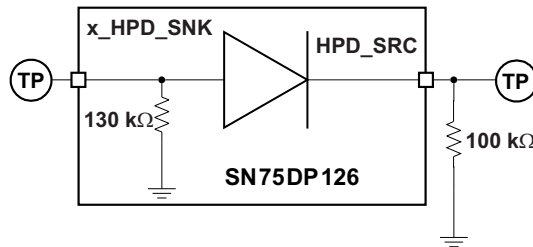

Figure 6. HPD Test Circuit

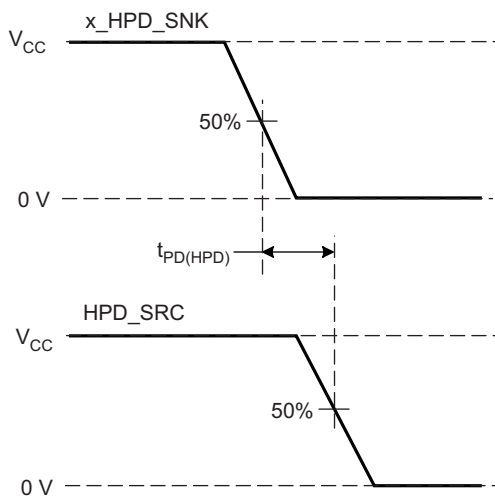

Figure 7. HPD Timing Diagram #1

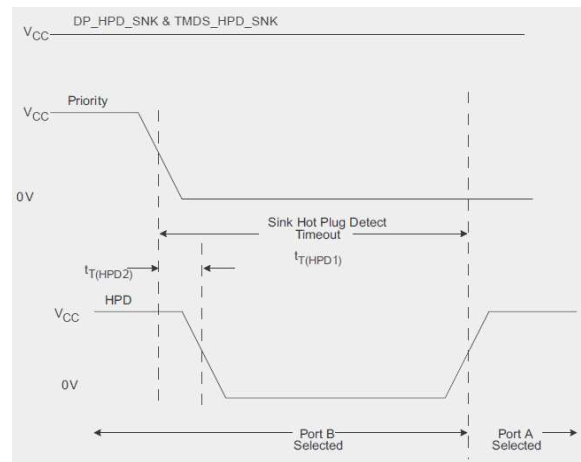

Figure 8. HPD Timing Diagram #2

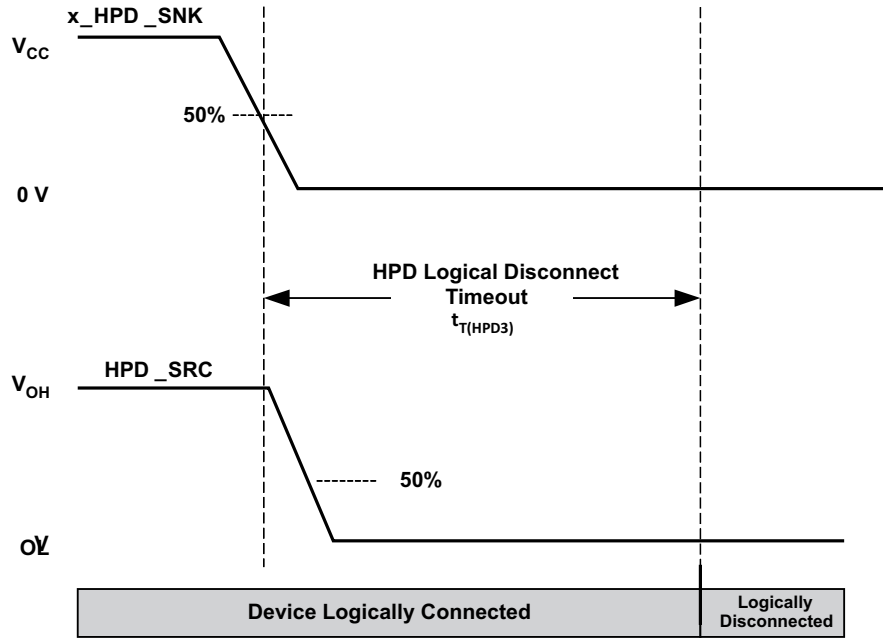

Figure 9. HPD Logic Disconnect Timeout

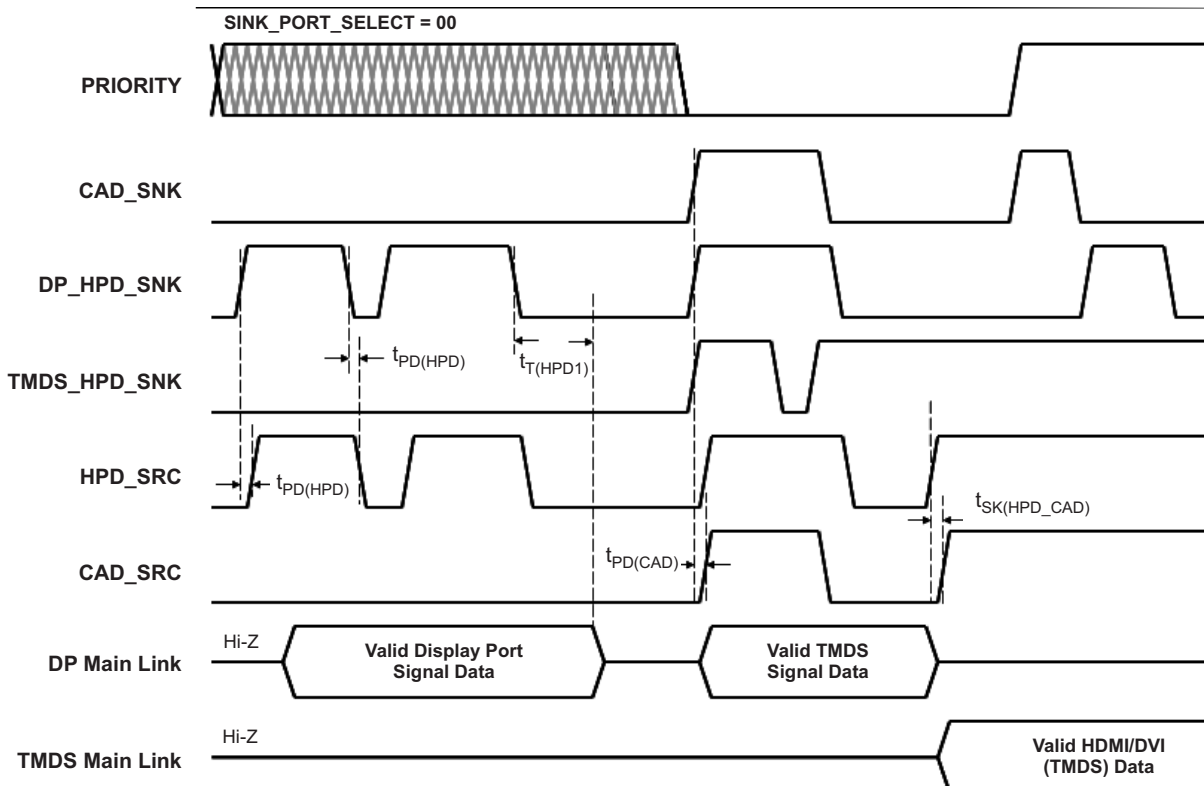

Figure 10. HPD and CAD Logic Description and Timing Diagram



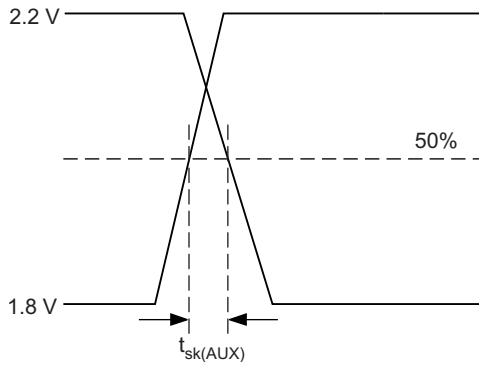

Figure 11. AUX Skew Measurement

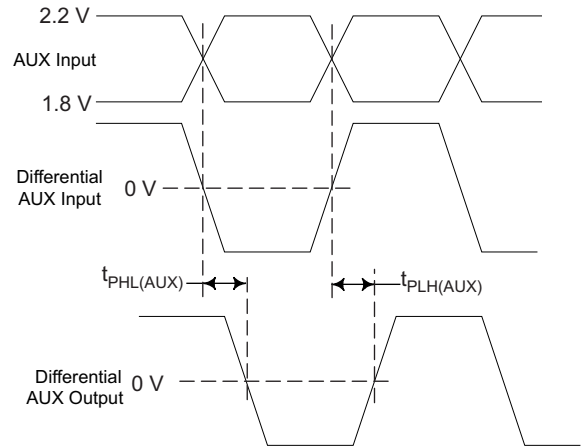

Figure 12. AUX Delay Measurement

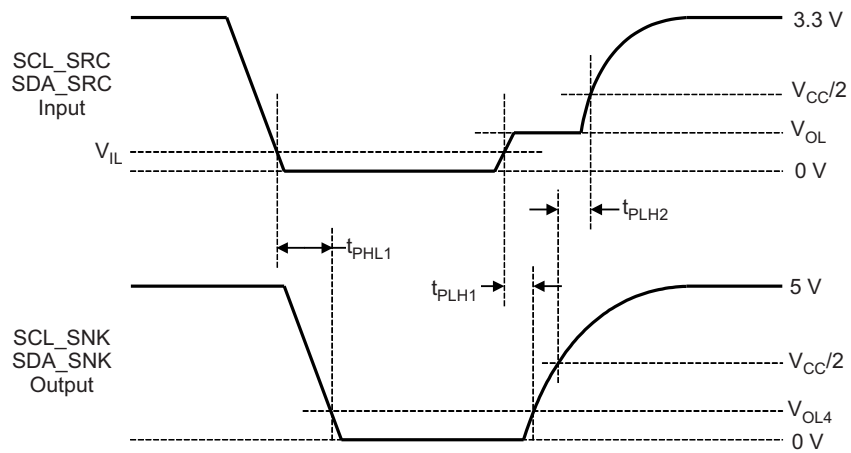

Figure 13. DDC Propagation Delay – Source to Sink

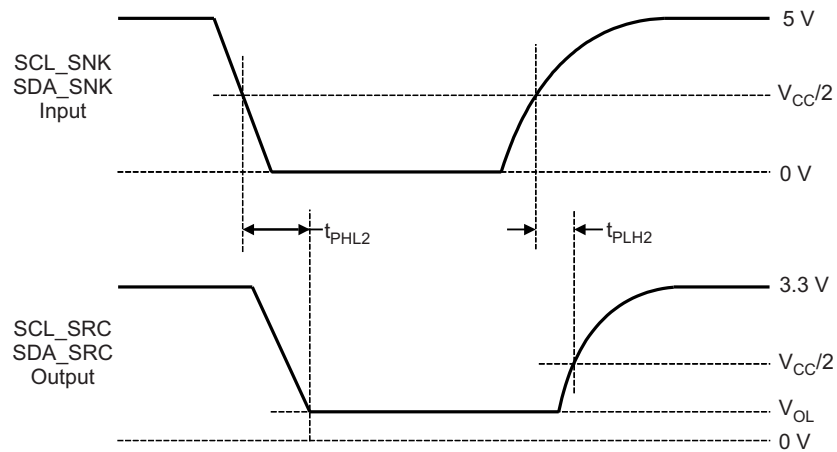

Figure 14. DDC Propagation Delay – Sink to Source

### 7.15 Typical Characteristics

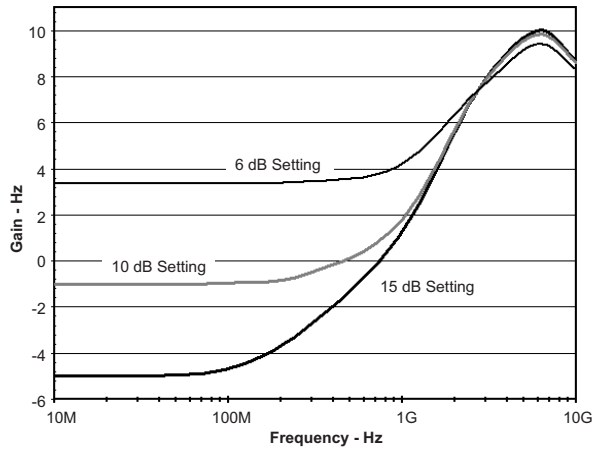
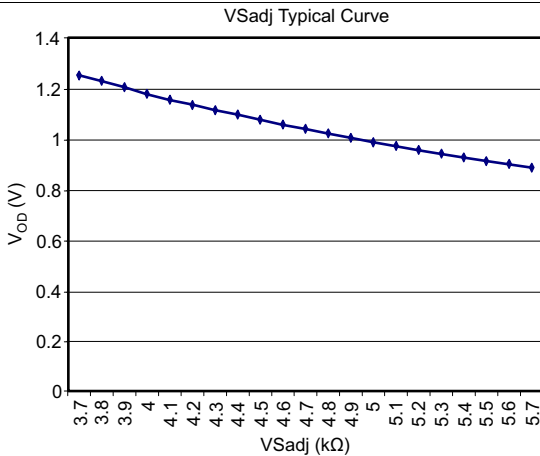

Figure 15. Typical EQ Gain Curves

| Input Mode          | Trace Length (inches) | Recommended Fixed EQ Setting |
|---------------------|-----------------------|------------------------------|
| DisplayPort<br>HBR2 | 2                     | 10dB                         |
|                     | 6                     | 10dB                         |
|                     | 10                    | 10dB                         |
|                     | 14                    | 13dB                         |
|                     | 18                    | 15dB                         |
| TMD5<br>3.4 Gbps    | 2                     | 13dB                         |
|                     | 6                     | 13dB                         |
|                     | 10                    | 13dB                         |
|                     | 14                    | 13dB                         |
|                     | 18                    | 15dB                         |
|                     | 22                    | 15dB                         |

Figure 16. Characterization Test Board Trace Lengths vs EQ Setting



Gain represents SN75DP126 design simulation.

Figure 17.  $V_{OD}$  vs.  $V_{Sadj}$

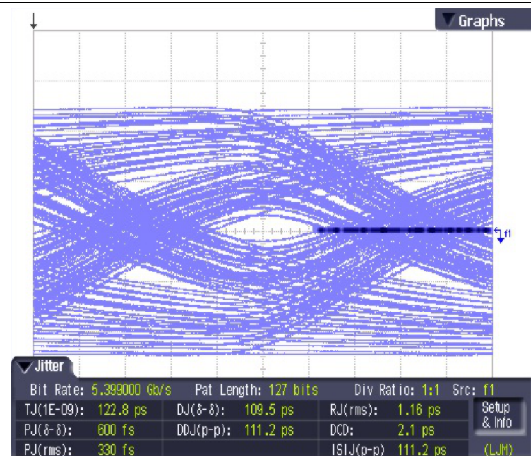

Figure 18. Main Link Input with 22-inch Trace; DisplayPort Sink

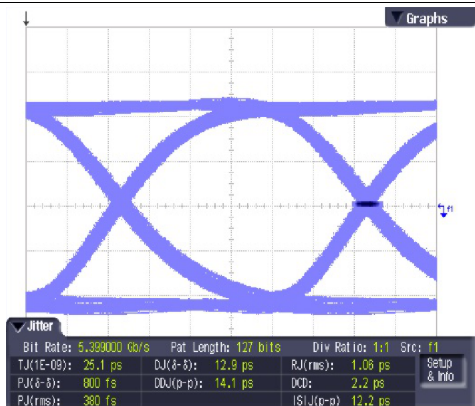

Figure 19. SN75DP126 Output; 22-inch Input Trace; 15 dB EQ Setting; DP Sink

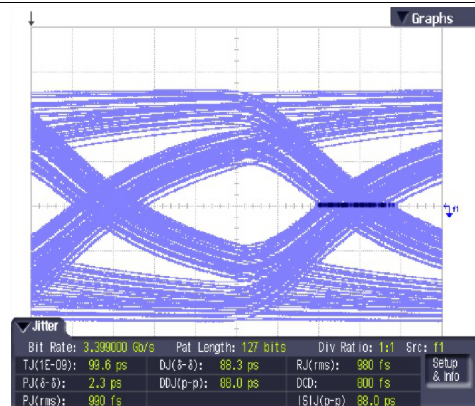
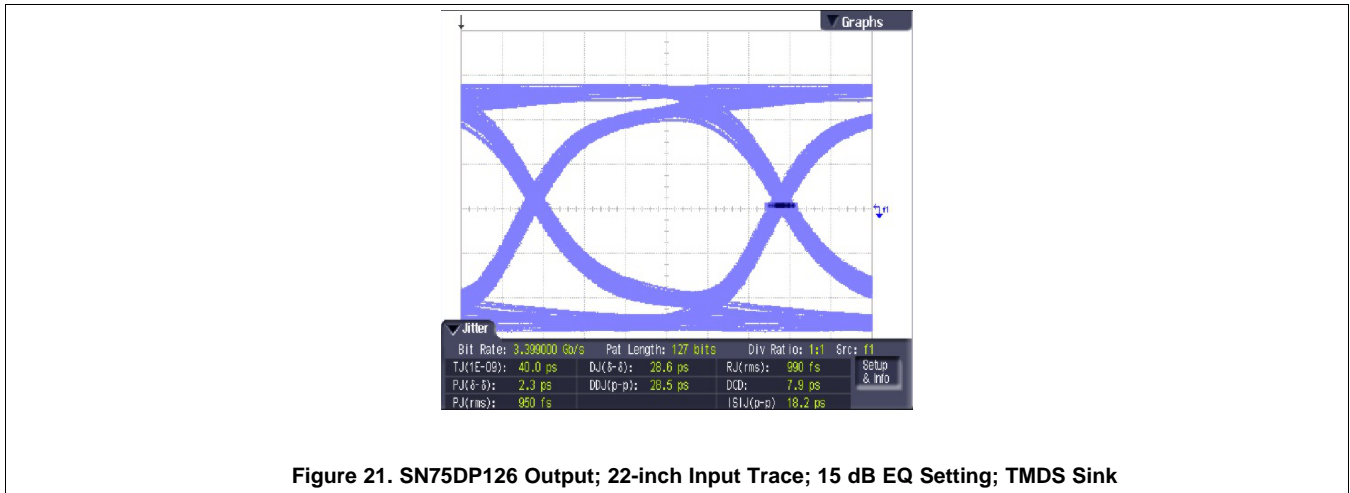

Figure 20. Main Link Input with 22-inch Trace; TMD5 Sink

**Typical Characteristics (continued)**



**Figure 21. SN75DP126 Output; 22-inch Input Trace; 15 dB EQ Setting; TMD5 Sink**

## 8 Detailed Description

### 8.1 Overview

The SN75DP126 compensates for PCB related frequency loss and switching related loss to provide the optimum electrical performance from source to SINK. THE DP++ main link signal inputs feature configurable equalizers with selectable boost settings.

The SN75DP126 switches one dual-mode Displayport (DP++) input to one Dual-mode Displayport (DP++) sink output or one HDMI/DVI sink output. The HDMI/DVI output has a built in level translator compliant with DVI 1.0 and HDMI 1.4A standard TMDS signaling, and is specified up to a maximum data rate of 3.5GBPS, supporting resolutions greater than 1920 x 1440 and HDTV deep color at 1080P. An integrated DP-HDMI adaptor ID buffer can be accessed when the HDMI/DVI sink is selected to indicate support for HDMI signaling.

### 8.2 Functional Block Diagram

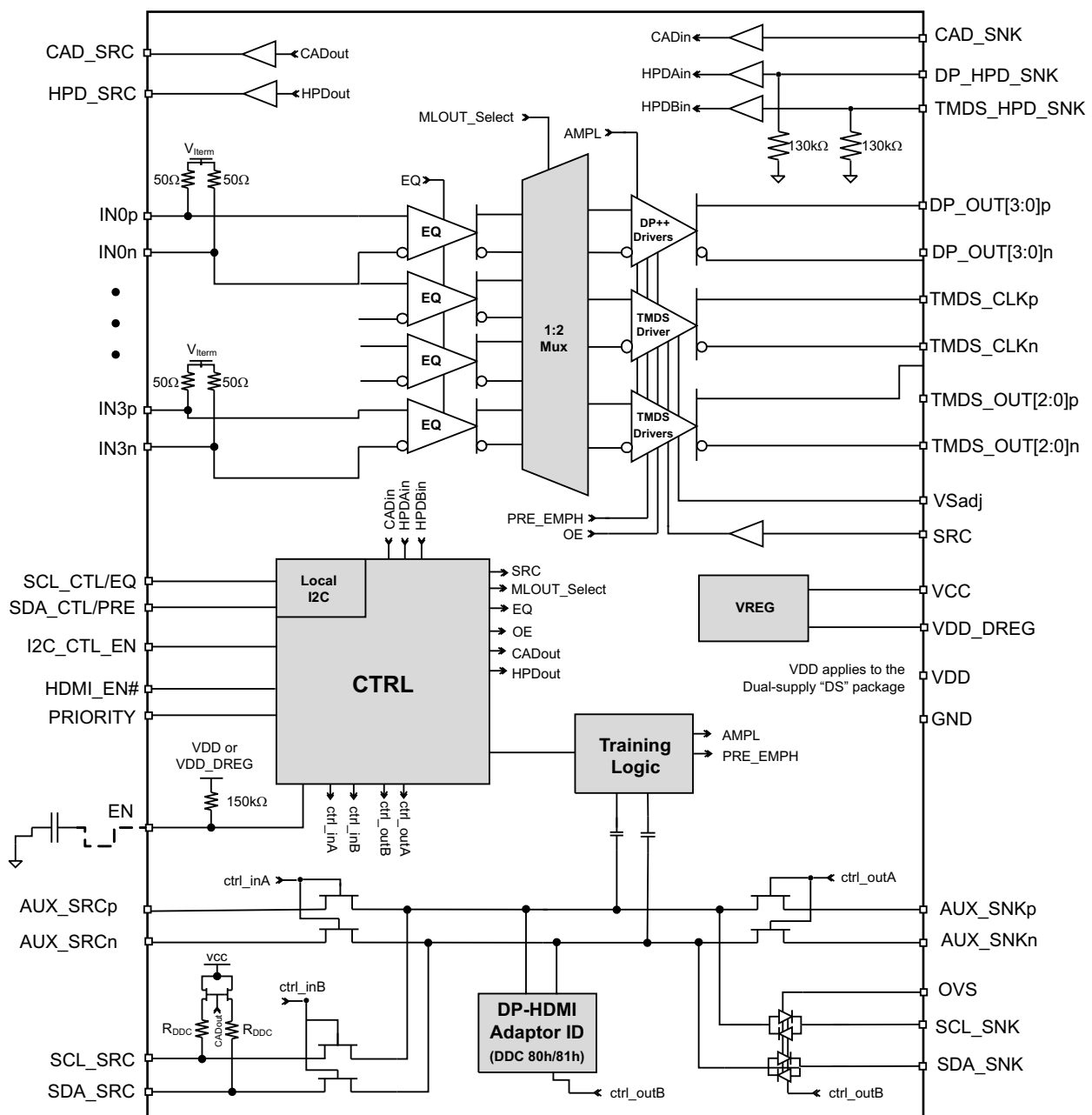

## 8.3 Feature Description

### 8.3.1 Implementing the EN Signal

The SN75DP126 EN input gives control over the device reset and to place the device into Shutdown mode. When EN is low, all DPCD and local I<sup>2</sup>C registers are reset to their default values, and all Main Link lanes are disabled.

It is critical to reset the digital logic of the SN75DP126 after the V<sub>CC</sub> supply (and V<sub>DD</sub> supply for SN75DP126DS) is stable (that is, the power supply has reached the minimum recommended operating voltage). To reset the digital logic, transition the EN input from a low level to a high level. This method is shown in Figure 22. A system may provide a control signal to the EN signal that transitions low to high after the power supply is (or supplies are) stable. An alternate implementation is to use an external capacitor connected between EN and GND to allow delaying the EN signal during power up, as shown in Figure 23.

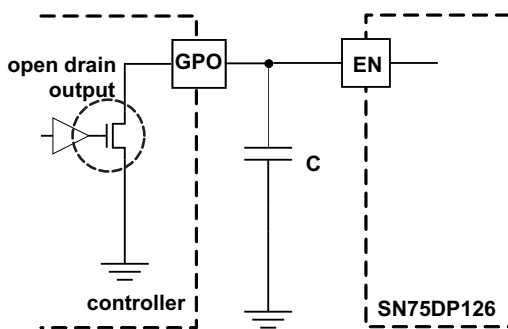

Figure 22. EN Input from Active Controller

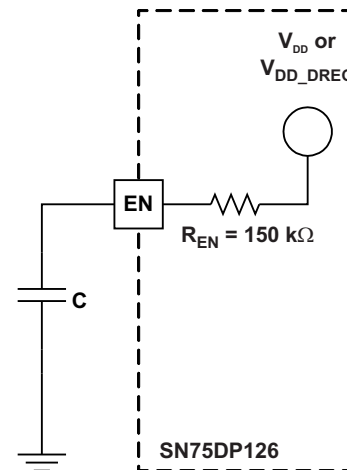

Figure 23. External Capacitor Controlled EN

When implementing the external capacitor, the size of the external capacitor depends on the power up ramp of the V<sub>CC</sub> (and V<sub>DD</sub> when applicable) supply, where a slower ramp-up results in a larger value external capacitor.

Refer to the latest reference schematic for the SN75DP126 device and/or consider approximately 200nF capacitor as a reasonable first estimate for the size of the external capacitor.

When implementing an EN input from an active controller, it is recommended to use an open drain driver if the EN input is driven. This protects the EN input from damage of an input voltage greater than V<sub>DD\_DREG</sub> (or V<sub>DD</sub>).

### 8.3.2 Hot Plug Detect (HPD) and Cable Adapter Detect (CAD) Description

The SN75DP126 drives the source-side Hot Plug Detect (HPD\_SRC) signal output high to indicate to the GPU or graphics source that at least one sink has been detected and selected for connectivity; when no sink is selected the HPD\_SRC is driven low. A high-level DP\_HP\_D\_SNK input indicates a DisplayPort sink device is connected, and a high-level TMDS\_HP\_D\_SNK input indicates a HDMI/DVI sink device is connected.

When DP\_HP\_D\_SNK is high, the DisplayPort sink is selected if the TMDS\_HP\_D\_SNK input is low. When TMDS\_HP\_D\_SNK is high, the HDMI/DVI sink is selected if the DP\_HP\_D\_SNK input is low. If both DP\_HP\_D\_SNK and TMDS\_HP\_D\_SNK inputs are high, then the PRIORITY input determines which sink is selected.

When the DisplayPort sink is selected, the CAD\_SNK input indicates whether a DP sink (CAD\_SNK = low) or a TMDS sink (CAD\_SNK = high) is connected. The level of CAD\_SNK is passed to the CAD\_SRC output when the DisplayPort sink is selected. When the HDMI/DVI sink is selected, the CAD\_SRC output is driven high regardless of the value input on CAD\_SRC.

A sink is determined to be disconnected when the corresponding HPD\_SNK input goes low for a duration of  $t_{T(HPD)}$ . When switching from one sink to the other based on the PRIORITY selection, that is, both sinks are connected and either PRIORITY has changed or the sink with higher PRIORITY was connected after the sink with lower PRIORITY, the SN75DP126 asserts HPD\_SRC for a duration at least  $t_{T(HPD)}$  before the switchover connection is established.

Through the local I<sup>2</sup>C interface it is possible to force the device to ignore DP\_HPDP\_SNK, TMDS\_HPDP\_SNK, and CAD\_SNK, and control HPD\_SRC and CAD\_SRC directly.

When the EN pin is de-asserted (device is in power down mode), the HPD path from DP\_HPDP\_SNK and/or TMDS\_HPDP\_SNK to HPD\_SRC is not reset. As a result, the source may need to retrain the link once EN is asserted (device is in active mode).

See [Figure 10](#) and [Table 1](#) for more information about the HPD and CAD functions.

### 8.3.3 OVS Function Description

The SN75DP126 provides an output-voltage select (OVS) control for the source side buffers on the DDC I<sup>2</sup>C lines. When the sink side is driven low, the corresponding source side driver turns on and drives the source side down to a low-level output voltage,  $V_{OL}$ . The value of  $V_{OL}$  and  $V_{IL}$  on the source side of the SN75DP126 depends on setting of the OVS pin.  $V_{OL}$  is always higher than  $V_{IL}$  on the source side to prevent lockup of the buffers on the DDC I<sup>2</sup>C lines. When the sink side is pulled up, the source side driver turns off and the sink side pin is high-impedance.

When the source side is driven below  $V_{IL}$  by an external I<sup>2</sup>C driver, both the sink and source side drivers are turned on. The sink side driver drives the sink side to near 0V, and the source side driver is on, but is overridden by the external I<sup>2</sup>C driver. When the source side is released by the external I<sup>2</sup>C driver, the source side driver is still on, so the source side is only able to rise to  $V_{OL}$ . However, the sink side driver turns off because the source side is above the  $V_{IL}$  threshold. If no external I<sup>2</sup>C driver is keeping the sink side low, the sink side rises causing the source side driver to turn off. See [Figure 13](#) and [Figure 14](#) for more information.

It is important that any external I<sup>2</sup>C driver on the source side is able to drive the bus below  $V_{IL}$  to achieve full operation. If the source side cannot be driven below  $V_{IL}$ , the sink side driver may not recognize and transmit the low value to the sink side.

### 8.3.4 AUX and DDC Configuration Details

The SN75DP126 connectivity between source-side AUX and DDC channels and the sink-side AUX and DDC channels is described in [Table 3](#). Refer to the BLOCK DIAGRAM for more information about the AUX and DDC switches, buffers, and logic elements represented in [Table 1](#).

Note that the DDC interface incorporates 60k $\Omega$  pull-up resistors on SDA\_SRC and SCL\_SRC which are enabled when CAD\_SRC is driven high, and disabled (turned off) when CAD\_SRC is driven low.

**Table 1. AUX and DDC Switch, Buffers, and Logic Element Control**

| INPUTS       |            |          |         | OUTPUTS AND CONTROLS         |                |                |                   |                                      |                             |   | COMMENTS   |
|--------------|------------|----------|---------|------------------------------|----------------|----------------|-------------------|--------------------------------------|-----------------------------|---|--|
| TMDS_HPD_SNK | DP_HPD_SNK | PRIORITY | CAD_SNK | CAD_SRC (Source-Side Output) | AUX_SRC SWITCH | DDC_SRC SWITCH | DP AUX_SNK SWITCH | HDMI/DVI DDC LEVEL-SHIFT I/O BUFFERS | AUX MONITOR (Link Training) | 14DP-HDMI ADAPTOR ID12 (1580h/81h DDC Buffer) |  |
| 0            | 0          | X        | 0       | 0 <sup>(1)</sup>             | OFF            | OFF            | OFF               | OFF                                  | OFF                         | OFF   | no sink selected; low power mode   |
|              |            |          | 1       | 1 <sup>(1)</sup>             |                |                |                   |                                      |                             |   |  |
| 0            | 1          | X        | 0       | 0                            | ON             | OFF            | ON                | OFF                                  | ON                          | OFF   | DisplayPort sink selected; operating in DP mode; AUX_SNK connects to AUX_SRC and Link Training enabled                                 |
| 1            | 1          | 0        |         |                              |                |                |                   |                                      |                             |   |  |
| 0            | 1          | X        | 1       | 1                            | OFF            | ON             | ON                | OFF                                  | OFF                         | OFF   | DisplayPort sink selected; operating in TMDS mode; AUX_SNK connects to source-side DDC (SCL/SDA_SRC)                                   |
| 1            | 1          | 0        |         |                              |                |                |                   |                                      |                             |   |  |
| 1            | 0          | X        | X       | 1                            | OFF            | ON             | OFF               | ON                                   | OFF                         | ON  | HDMI/DVI sink selected; connect the source-side DDC to sink-side DDC; enable the DP-HDMI Adaptor ID accessed via DDC addresses 80h/81h |
| 1            | 1          | 1        |         |                              |                |                |                   |                                      |                             |   |  |

(1) After transitioning from HDMI/DVI mode to low power mode, CAD\_SRC will remain high regardless of the status of CAD\_SNK



### 8.3.5 Source-Side Main Link EQ Configuration Details

A variety of EQ settings are available through external pin configuration to accommodate for different PCB loss and GPU settings. The I<sup>2</sup>C interface is utilized to fully customize EQ configuration, lane-by-lane, beyond the input pin configuration options, as described in [Table 2](#).

**Table 2. Source-Side Main Link EQ Configurations**

| INPUTS        |                 |               |                 |            |                 |                      | EQ SETTINGS     |   |   |   |   |   |                                 |                  |                   |                  |
|---------------|-----------------|---------------|-----------------|------------|-----------------|----------------------|-----------------|---|---|---|---|---|---------------------------------|------------------|-------------------|------------------|
| EQ_I2C_ENABLE | (Register 05.7) | I2C_CTL_EN    | (3-Level Input) | SCL_CTL/EQ | (3-Level Input) | LINK_TRAINING_ENABLE | (Register 04.2) | DISPLAYPORT SIGNAL MODE <sup>(1)(2)</sup>   | SOURCE LANES IN[3:0]  | TMDS SIGNAL MODE <sup>(3)</sup>   | (TMDS DATA)   | SOURCE LANES IN[2:0]  | TMDS SIGNAL MODE <sup>(3)</sup> | (TMDS CLOCK)     | SOURCE LANE IN[3] |                  |
| 0             | $\leq V_{IL}$   | $\leq V_{IL}$ | X               | 1          | 1               | 1                    | 1               | AEQ(L0) = 8 dB at 2.7 GHz<br>AEQ(L1) = 6 dB at 2.7 GHz<br>AEQ(L2) = 3.5 dB at 2.7 GHz<br>AEQ(L3) = 0 dB at 2.7 GHz            | 6 dB at 2.7 GHz   | 6 dB at 2.7 GHz   | 6 dB at 2.7 GHz   | 13 dB at 2.7 GHz  | 13 dB at 2.7 GHz                | 3 dB at 1.35 GHz | 3 dB at 1.35 GHz  |                  |
|               |                 |               |                 |            |                 |                      |                 |   |   |   |   |   |                                 |                  |                   | 0                |
|               |                 | $\geq V_{IH}$ | X               | X          | 1               | 1                    | 1               | 1   | AEQ(L0) = 15 dB at 2.7 GHz<br>AEQ(L1) = 13 dB at 2.7 GHz<br>AEQ(L2) = 10 dB at 2.7 GHz<br>AEQ(L3) = 6 dB at 2.7 GHz                             | 13 dB at 2.7 GHz  | 13 dB at 2.7 GHz  | 13 dB at 2.7 GHz  | 18 dB at 2.7 GHz                | 18 dB at 2.7 GHz | 3 dB at 1.35 GHz  | 3 dB at 1.35 GHz |
|               |                 |               |                 |            |                 |                      |                 |   |   |   |   |   |                                 |                  |                   |                  |
|               | $\geq V_{IH}$   | X             | X               | X          | 1               | 1                    | 1               | AEQ(Lx) = 0 dB at 2.7 GHz (default)<br>EQ settings for each link training level<br>can be selected via local I <sup>2</sup> C | 0 dB at 2.7 GHz (default)<br>EQ settings selected via local I <sup>2</sup> C,<br>training level L1<br>(AEQ_L1_LANE <sub>x</sub> _SET registers) | 0 dB at 2.7 GHz (default)<br>EQ settings selected via local I <sup>2</sup> C,<br>training level L1<br>(AEQ_L1_LANE <sub>x</sub> _SET registers) | 0 dB at 2.7 GHz (default)<br>EQ settings selected via local I <sup>2</sup> C,<br>training level L1<br>(AEQ_L1_LANE <sub>x</sub> _SET registers) | 0 dB at 2.7 GHz (default)<br>EQ settings selected via local I <sup>2</sup> C,<br>training level L1<br>(AEQ_L1_LANE <sub>x</sub> _SET registers) | 18 dB at 2.7 GHz                | 18 dB at 2.7 GHz | 3 dB at 1.35 GHz  | 3 dB at 1.35 GHz |
|               |                 |               |                 |            |                 |                      |                 |   |   |   |   |   |                                 |                  |                   |                  |

(1) DisplayPort mode is active when the DisplayPort sink is selected and the CAD\_SNK input is low

(2) In DisplayPort signaling mode, the EQ gain may be applied after the Link Training is complete

(3) TMDS mode is active when the DisplayPort sink is selected and the CAD\_SNK input is high, or when the HDMI/DVI sink is selected

### 8.3.6 DP-HDMI Adaptor ID Buffer

The SN75DP126 includes the DP-HDMI adapter ID buffer for HDMI/DVI adaptor recognition, defined by the VESA DisplayPort Interoperability Guidelines Version 1.1a, accessible by standard I<sup>2</sup>C protocols through the DDC interface when the HDMI/DVI sink is selected. The DP-HDMI adapter buffer is accessed at target addresses 80h (Write) and 81h (Read).

The DP-HDMI adapter buffer contains a read-only phrase DP-HDMI ADAPTOR<EOT> converted to ASCII characters as illustrated in [Table 3](#), and supports the Write command procedures (accessed at target address 80h) to select the sub-address, as recommended in the VESA DisplayPort Interoperability Guideline Adaptor Checklist Version 1.0 section 2.3.

**Table 3. SN75DP126 DP-HDMI Adaptor ID Buffer**

| Address | 0x00 | 0x01 | 0x02 | 0x03 | 0x04 | 0x05 | 0x06 | 0x07 | 0x08 | 0x09 | 0x0A | 0x0B | 0x0C | 0x0D | 0x0E | 0x0F | 0x10 |
|---------|------|------|------|------|------|------|------|------|------|------|------|------|------|------|------|------|------|
| Data    | 44   | 50   | 2D   | 48   | 44   | 4D   | 49   | 20   | 41   | 44   | 41   | 50   | 54   | 4F   | 52   | 04   | FF   |

### 8.3.7 GPU with a Unified AUX/DDC Configuration

The SN75DP126 supports graphics processors with unified AUX/DDC configurations, where the source AUX channel is multiplexed with the source DDC channel, as illustrated in Figure 24.

Graphics processors with separate AUX and DDC channels (ie. non-unified) are also supported, where the separate channels are directly routed to the separate channels on the the SN75DP126, maintaining the AC coupling on the AUX channel. In the non-unified configuration, it is recommended to implement 2-k $\Omega$  pull-up resistors on the source-side DDC channel. See Figure 25.

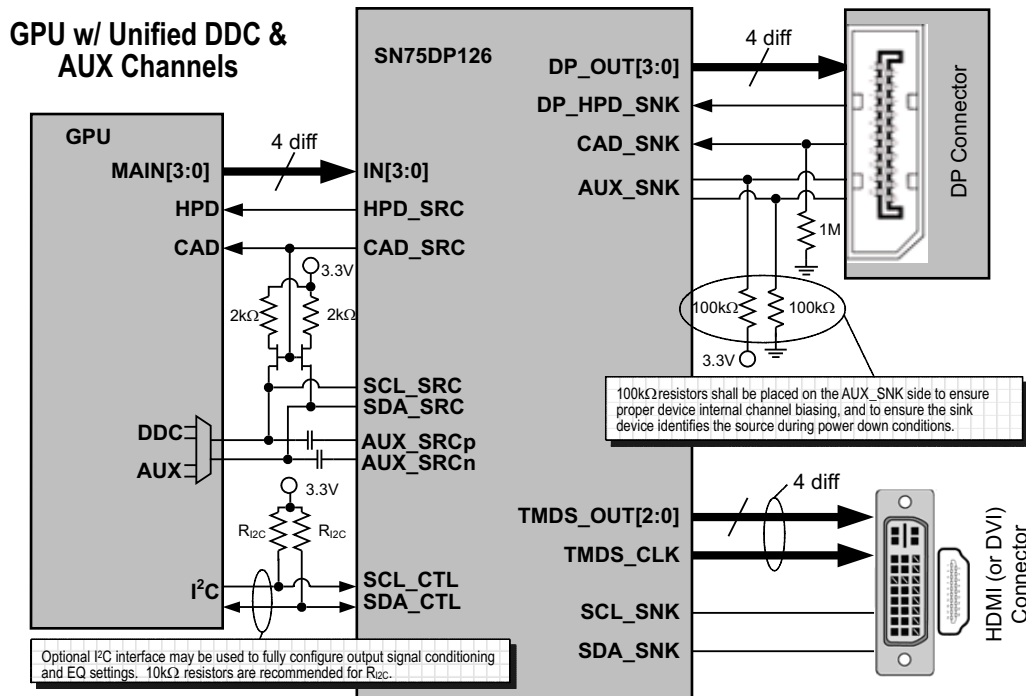

**Figure 24. GPU with a Unified AUX/DDC Configuration**

### 8.3.8 GPU with Separate DDC and AUX Channels

Graphics processors with separate AUX and DDC channels (ie. non-unified) are also supported, where the separate channels are directly routed to the separate channels on the the SN75DP126, maintaining the AC coupling on the AUX channel. In the non-unified configuration, it is recommended to implement 2-k $\Omega$  pull-up resistors on the source-side DDC channel. See Figure 25.

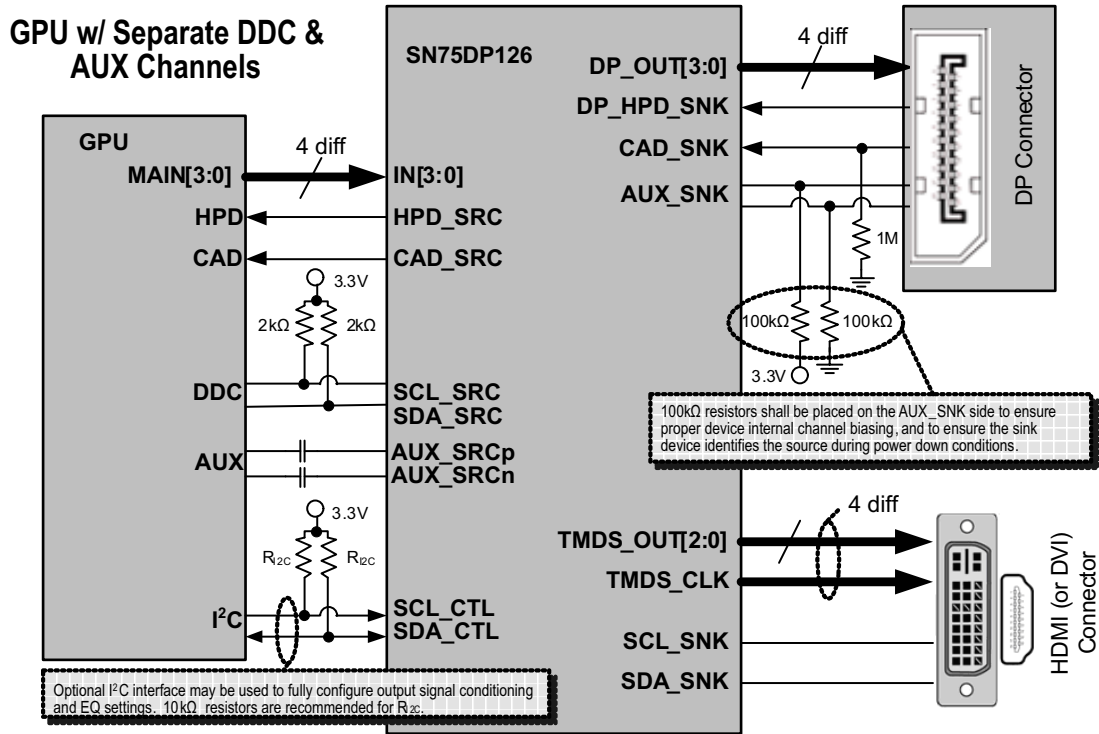

Figure 25. GPU with Separate DDC and AUX Channels

## 8.4 Device Functional Modes

### 8.4.1 Operating Modes Overview

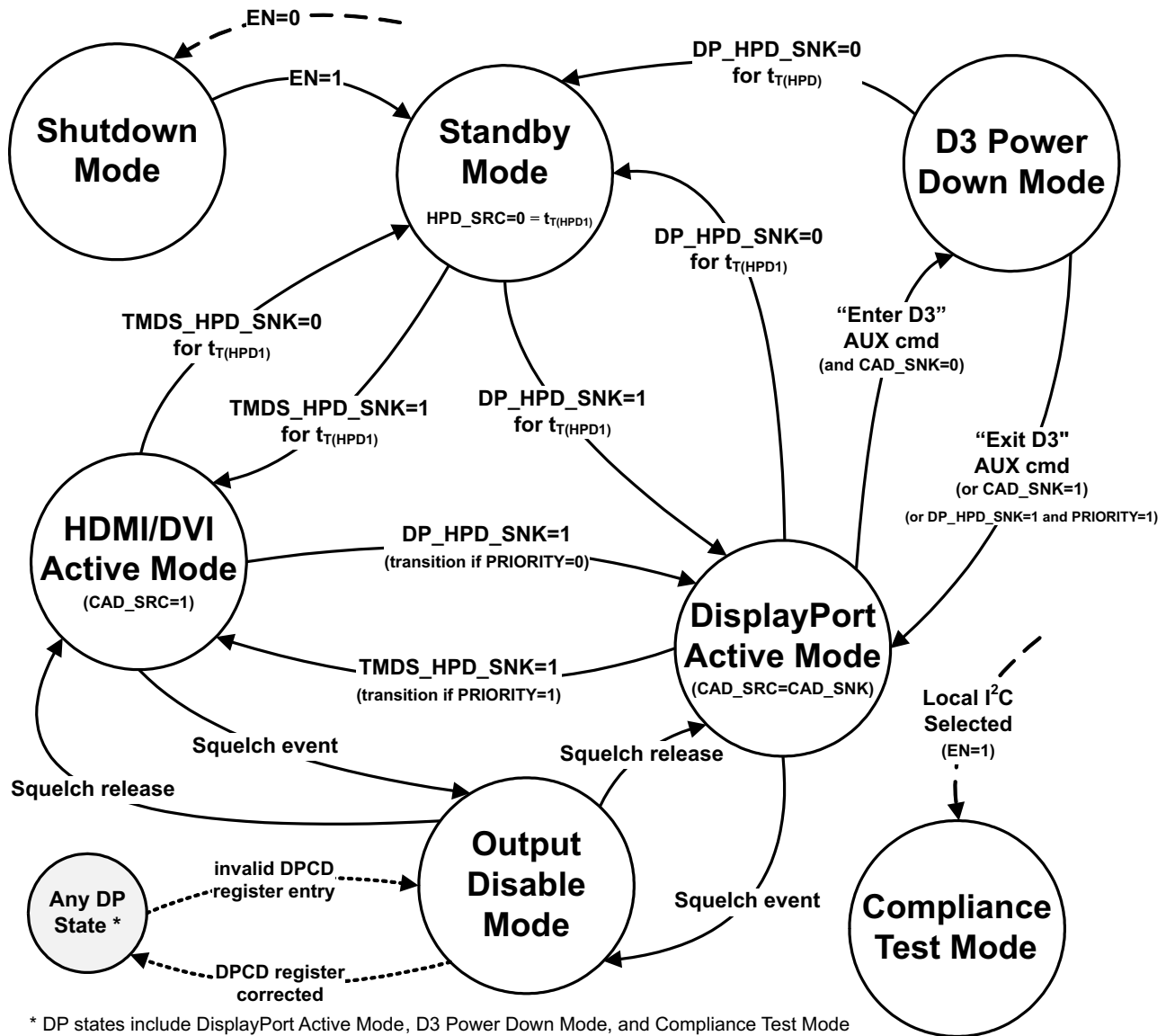

Figure 26. SN75DP126 Operating Modes Flow Diagram

**Device Functional Modes (continued)**
**Table 4. Description of SN75DP126 Operating Modes**

| MODE                    | CHARACTERISTICS  | CONDITIONS   |
|-------------------------|--|--|
| Shutdown Mode           | Least amount of power consumption (most circuitry turned off); HPD_SRC output is asserted if either DP_HPD_SNK or TMDS_HPD_SNK are input active (high); all other outputs are high-impedance; all other inputs are ignored; the local I <sup>2</sup> C interface is inactive; in this state all local I <sup>2</sup> C registers and DPCD registers are set to default values.   | EN is low  |
| Standby Mode            | Main Link outputs are disabled; the local I <sup>2</sup> C interface is active; in this state, the HPD_SRC (and CAD_SRC) outputs are driven low for at least t <sub>T(HPD)</sub> to indicate no sink connectivity to the source; the SN75DP126 passes through this state when transitioning from one active sink to the other for reasons of PRIORITY selection, where the HPD_SRC de-assertion for at least t <sub>T(HPD)</sub> communicates the sink plug event to the source.   | EN is high;<br>Either no sink is connected, or both sinks are connected and PRIORITY causes a transition from one sink to the other sink   |
| DisplayPort Active Mode | The DisplayPort sink is selected and data transfer is enabled (normal operation); the Main Link output is either TMDS mode (CAD_SNK = 1) or DisplayPort mode (CAD_SNK = 0).  | EN is high;<br>DP_HPD_SNK is high, but after entering this state, DP_HPD_SNK can be low for less than t <sub>T(HPD)</sub> (for example, sink interrupt request to source);<br>If both TMDS_HPD_SNK and DP_HPD_SNK are high, then a low input on PRIORITY causes the DisplayPort sink selection |
|                         | In TMDS mode, the DDC source-side channel (SCL/SDA_SRC) is connected to the sink DDC channel (AUX_SNK p/n) through a low-resistance circuit; and the CAD_SRC output is driven high. In TMDS mode the output signal swing is 600 mVpp unless this setting is adjusted through local I <sup>2</sup> C interface programming; the Main Link input equalizer settings depend on device control inputs and local I <sup>2</sup> C settings.<br><br>In DisplayPort mode the AUX source-side channel is connected to the sink AUX channel through a low-resistance circuit; and the CAD_SRC output is driven low. The AUX monitor is active for Link Training, which automatically updates the DPCD registers to enable the Main Link outputs (this Link Training operation may be de-activated and overridden by direct local I <sup>2</sup> C programming); transactions other than Link Training and D3 power management commands are ignored on the AUX interface; the Main Link output signal conditioning (pre-emphasis and V <sub>OD</sub> ) and Main Link input equalizer settings depend on the Link Training, device control inputs, and local I <sup>2</sup> C settings. |  |
| D3 Power Down Mode      | DisplayPort D3 low-power mode; DisplayPort sink Main Link outputs are disabled; local I <sup>2</sup> C interface is active; AUX monitor is active.   | EN is high;<br>DisplayPort sink is selected, and operating in DisplayPort mode (CAD_SNK = 0); "Enter D3" AUX command has been performed  |
| HDMI/DVI Active Mode    | The HDMI/DVI sink is selected and data transfer is enabled (normal operation); the HDMI/DVI Main Link output (TMDS signaling) is enabled.  | EN is high;<br>TMDS_HPD_SNK is high;<br>If both TMDS_HPD_SNK and DP_HPD_SNK are high, then a high input on PRIORITY causes the HDMI/DVI sink selection   |
|                         | The DDC source-side channel (SCL/SDA_SRC) is connected to the HDMI/DVI sink DDC channel (SCL/SDA_SNK) through an I <sup>2</sup> C buffer that separates the capacitive load between the source and sink; the DP-HDMI Adapter ID buffer containing a read-only phrase DP-HDMI ADAPTOR<EOT> converted to ASCII characters at DDC (I <sup>2</sup> C target) addresses 80h(Write)/81h(Read) per the VESA DisplayPort Interoperability Guidelines Version 1.1a  |  |
|                         | The HDMI/DVI Main Link output signal conditioning (pre-emphasis and V <sub>OD</sub> ) and Main Link input equalizer settings depend on the device control inputs and local I <sup>2</sup> C settings.  |  |
| Output Disable Mode     | When low-signal levels on the source Main Link input are sensed (a squelch event) when in either sink-side is selected for active mode, a transition to this state occurs and the sink-side Main Link outputs are disabled; when the source Main Link input signal levels are above a pre-determined threshold, a transition back to the appropriate active mode occurs.   | EN is high;<br>DPCD register 101h or 103h entry is invalid   |
|                         | Other than a disabled Main Link output, this state characteristics are identical to the active state from where the transition occurred.   |  |
|                         | A transition to this state may occur from DisplayPort Active Mode, D3 Power Down Mode, or Compliance Test Mode when DPCD writes (from the local I <sup>2</sup> C or the AUX channel) update the DPCD 101h or 103h registers with invalid values; this action causes the DP sink to issue an interrupt and re-train the link.   |  |
| Compliance Test Mode    | Through local I <sup>2</sup> C registers the device can be forced into ignoring TMDS_HPD_SNK, DP_HPD_SNK, and CAD_SNK; HPD_SRC and CAD_SRC outputs are programmed through local I <sup>2</sup> C registers (default output low); all other configurations (such as output signal conditioning and EQ settings) are programmable through the local I <sup>2</sup> C registers in this state.  | EN is high;<br>Local I <sup>2</sup> C programming selects the this mode  |

## 8.5 Register Maps

### 8.5.1 Link Training and DPCD Description

The SN75DP126 can monitor the auxiliary interface access to DisplayPort Configuration Data (DPCD) registers during Link Training in DisplayPort mode, to select the output voltage swing  $V_{OD}$ , output pre-emphasis, and the EQ setting of the Main Link. The AUX monitor for SN75DP126 supports Link Training in 1-Mbps Manchester mode, and is disabled during TMDS modes of operation.

The DPCD registers monitored by SN75DP126 are listed below. Bit fields not listed are reserved and values written to reserved fields are ignored.

**Table 5. DPCD Registers Utilized by the SN75DP126 AUX Monitor**

| ADDRESS | NAME               | DESCRIPTION   |
|---------|--------------------|---|
| 00100h  | LINK_BW_SET        | Bits 7:0 = Link Bandwidth Setting<br>Write Values:<br>06h – 1.62 Gbps per lane<br>0Ah – 2.7 Gbps per lane (default)<br>14h – 5.4 Gbps per lane<br><i>Note: any other value is reserved; the SN75DP126 will revert to 5.4 Gbps operation when any other value is written</i><br>Read Values:<br>00h – 1.62 Gbps per lane<br>01h – 2.7 Gbps per lane (default)<br>02h – 5.4 Gbps per lane   |
| 00101h  | LANE_COUNT_SET     | Bits 4:0 = Lane Count<br>Write Values:<br>0h – All lanes disabled (default)<br>1h – One lane enabled<br>2h – Two lanes enabled<br>4h – Four lanes enabled<br><i>Note: any other value is invalid and disables all Main Link output lanes</i><br>Read Values:<br>0h – All lanes disabled (default)<br>1h – One lane enabled<br>3h – Two lanes enabled<br>Fh – Four lanes enabled   |
| 00103h  | TRAINING_LANE0_SET | Write Values:<br>Bits 1:0 = Output Voltage $V_{OD}$ Level<br>00 – Voltage swing level 0 (default)<br>01 – Voltage swing level 1<br>10 – Voltage swing level 2<br>11 – Voltage swing level 3<br>Bits 4:3 = Pre-emphasis Level<br>00 – Pre-emphasis level 0 (default)<br>01 – Pre-emphasis level 1<br>10 – Pre-emphasis level 2<br>11 – Pre-emphasis level 3<br><i>Note: the following combinations are not allowed for bits [1:0]/[4:3]: 01/11, 10/10, 10/11, 11/01, 11/10, 11/11; setting to any of these invalid combinations disables all Main Link lanes until the register value is changed back to a valid entry</i><br>Read Values:<br>Bits 1:0 = Output Voltage $V_{OD}$ Level<br>00 – Voltage swing level 0 (default)<br>01 – Voltage swing level 1<br>10 – Voltage swing level 2<br>11 – Voltage swing level 3<br>Bits 3:2 = Pre-emphasis Level<br>00 – Pre-emphasis level 0 (default)<br>01 – Pre-emphasis level 1<br>110 – Pre-emphasis level 2<br>11 – Pre-emphasis level 3 |
| 00104h  | TRAINING_LANE1_SET | Sets the $V_{OD}$ and pre-emphasis levels for lane 1  |
| 00105h  | TRAINING_LANE2_SET | Sets the $V_{OD}$ and pre-emphasis levels for lane 2  |
| 00106h  | TRAINING_LANE3_SET | Sets the $V_{OD}$ and pre-emphasis levels for lane 3  |

**Register Maps (continued)**
**Table 5. DPCD Registers Utilized by the SN75DP126 AUX Monitor (continued)**

| ADDRESS | NAME                  | DESCRIPTION   |
|---------|-----------------------|---|
| 0010F   | TRAINING_LANE0_1_SET2 | Write Values:<br>Bits 1:0 = Lane 0 Post Cursor 2<br>00 – IN0 expects post cursor2 level 0; OUT0 transmits at post cursor 2 level 0<br>01 – IN0 expects post cursor2 level 1; OUT0 transmits at post cursor 2 level 0<br>10 – IN0 expects post cursor2 level 2; OUT0 transmits at post cursor 2 level 0<br>11 – IN0 expects post cursor2 level 3; OUT0 transmits at post cursor 2 level 0<br>Bits 5:4 = Lane 1 Post Cursor 2<br>00 – IN1 expects post cursor2 level 0; OUT1 transmits at post cursor 2 level 0<br>01 – IN1 expects post cursor2 level 1; OUT1 transmits at post cursor 2 level 0<br>10 – IN1 expects post cursor2 level 2; OUT1 transmits at post cursor 2 level 0<br>11 – IN1 expects post cursor2 level 3; OUT1 transmits at post cursor 2 level 0<br>Read Values:<br>Bits 1:0 = Lane 0 Post Cursor 2<br>00 – IN0 expects post cursor2 level 0; OUT0 transmits at post cursor 2 level 0<br>01 – IN0 expects post cursor2 level 1; OUT0 transmits at post cursor 2 level 0<br>10 – IN0 expects post cursor2 level 2; OUT0 transmits at post cursor 2 level 0<br>11 – IN0 expects post cursor2 level 3; OUT0 transmits at post cursor 2 level 0<br>Bits 3:2 = Lane 1 Post Cursor 2<br>00 – IN1 expects post cursor2 level 0; OUT1 transmits at post cursor 2 level 0<br>01 – IN1 expects post cursor2 level 1; OUT1 transmits at post cursor 2 level 0<br>10 – IN1 expects post cursor2 level 2; OUT1 transmits at post cursor 2 level 0<br>11 – IN1 expects post cursor2 level 3; OUT1 transmits at post cursor 2 level 0 |
| 0110F   | TRAINING_LANE2_3_SET2 | Bit definition identical to that of TRAINING_LANE_0_1_SET2 but for lanes 2 (IN2/OUT2) and lane 3 (IN3/OUT3)   |
| 00600h  | SET_POWER             | Bits 1:0 = Power Mode<br>Write Values:<br>01 – Normal mode (default)<br>10 – Power down mode; D3 Standby Mode<br>The Main Link and all analog circuits are shut down and the AUX channel is monitored during the D3 Standby Mode. The device exits D3 Standby Mode by access to this register, when CAD_SNK goes high, or if DP_HPD_SNK goes low for longer than $t_{\text{THPD}}$ , which indicates that the DP sink was disconnected, or that the PRIORITY control has selected the HDMI/DVI sink.<br><i>Note: setting the register to the invalid combination 0600h[1:0] = 00 or 11 is ignored by the device and the device remains in normal mode</i><br>Read Values:<br>00 – Normal mode (default)<br>01 – Power-down mode; D3 Standby Mode  |

**8.5.2 Local I<sup>2</sup>C Interface Overview**

The SN75DP126 local I<sup>2</sup>C interface is enabled when EN is input high, and the I2C\_CTL\_EN control input is not input low. The SCL\_CTL and SDA\_CTL terminals are used for I<sup>2</sup>C clock and I<sup>2</sup>C data respectively. The SN75DP126 I<sup>2</sup>C interface conforms to the two-wire serial interface defined by the I<sup>2</sup>C Bus Specification, Version 2.1 (January 2000), and supports the standard mode transfer up to 100 kbps.

The device address byte is the first byte received following the START condition from the master device. The 7 bit device address for SN75DP126 is factory preset to 010110x with the least significant bit being determined by the I2C\_CTL\_EN 3-level control input. [Table 6](#) clarifies the SN75DP126 target address.

**Table 6. SN75DP126 I<sup>2</sup>C Target Address Description**

| SN75DP126 I <sup>2</sup> C TARGET ADDRESS |       |       |       |       |       |       |             |
|---|-------|-------|-------|-------|-------|-------|-------------|
| BIT 7 (MSB)                               | BIT 6 | BIT 5 | BIT 4 | BIT 3 | BIT 2 | BIT 1 | BIT 0 (W/R) |
| 0   | 1     | 0     | 1     | 1     | 0     | X     | 0/1         |

I2C\_CTL\_EN = Low : Local I<sup>2</sup>C interface is disabled.  
 I2C\_CTL\_EN = Between V<sub>IL</sub> and V<sub>IH</sub>: X = 0, Address Cycle is 0x58 (Write) and 0x59 (Read).  
 I2C\_CTL\_EN = High: X = 1, Address Cycle is 0x5A (Write) and 0x5B (Read).

The following procedure is followed to write to the SN75DP126 I<sup>2</sup>C registers:

1. The master initiates a write operation by generating a start condition (S), followed by the SN75DP126 7-bit address and a zero-value “W/R” bit to indicate a write cycle
2. The SN75DP126 acknowledges the address cycle



3. The master presents the sub-address (I<sup>2</sup>C register within SN75DP126) to be written, consisting of one byte of data, MSB-first
4. The SN75DP126 acknowledges the sub-address cycle
5. The master presents the first byte of data to be written to the I<sup>2</sup>C register
6. The SN75DP126 acknowledges the byte transfer
7. The master may continue presenting additional bytes of data to be written, with each byte transfer completing with an acknowledge from the SN75DP126
8. The master terminates the write operation by generating a stop condition (P)

The following procedure is followed to read the SN75DP126 I<sup>2</sup>C registers.

1. The master initiates a read operation by generating a start condition (S), followed by the SN75DP126 7-bit address and a one-value “W/R” bit to indicate a read cycle
2. The SN75DP126 acknowledges the address cycle
3. The SN75DP126 transmit the contents of the memory registers MSB-first starting at register 00h
4. The SN75DP126 will wait for either an acknowledge (ACK) or a not-acknowledge (NACK) from the master after each byte transfer; the I<sup>2</sup>C master acknowledges reception of each data byte transfer
5. If an ACK is received, the SN75DP126 transmits the next byte of data
6. The master terminates the read operation by generating a stop condition (P)

Note that no sub-addressing is included for the read procedure, and reads start at register offset 00h and continue byte by byte through the registers until the I<sup>2</sup>C master terminates the read operation.

Refer to [Table 7](#) for SN75DP126 local I<sup>2</sup>C register descriptions. Reads from reserved fields not described return zeros, and writes are ignored.

**Table 7. SN75DP126 Local I<sup>2</sup>C Control and Status Registers**

| ADDRESS | BIT(S) | DESCRIPTION  | ACCESS |
|---------|--------|--|--------|
| 01h     | 3:2    | SINK_PORT_SELECT<br>00 – DP_HPD_SNK and TMDS_HPD_SNK select the sink; when both are asserted, the PRIORITY control input is used where PRIORITY = LOW selects the DisplayPort sink (default)<br>01 – DP_HPD_SNK and TMDS_HPD_SNK select the sink; when both are asserted, the PRIORITY control input is used where PRIORITY = LOW selects the HDMI/DVI sink<br>10 – Force DisplayPort sink selection regardless of device HPD and control inputs<br>11 – Force HDMI/DVI sink selection regardless of device HPD and control inputs | RW     |
|         | 1      | FORCE_HPD_SRC<br>0 – Enter Standby mode when DP_HPD_SNK and TMDS_HPD_SNK are input low, and drive HPD_SRC high when DP_HPD_SNK or TMDS_HPD_SNK are input high (default)<br>1 – Drive HPD_SRC output high regardless of DP_HPD_SNK and TMDS_HPD_SNK inputs  | RW     |
|         | 0      | FORCE_SHUTDOWN_MODE<br>0 – SN75DP126 is forced to Shutdown mode<br>1 – Shutdown mode is determined by EN input, normal operation (default)   | RW     |
| 02h     | 7:0    | TI_TEST. This field defaults to zero value, and should not be modified.  | RW     |
| 03h     | 5:4    | SQUELCH_SENSITIVITY. Input Main Link squelch sensitivity is selected by this field, and determines the transitions to and from the Output Disable mode.<br>00 – Main Link IN0p/n squelch detection threshold set to 60 mVpp<br>01 – Main Link IN0p/n squelch detection threshold set to 115 mVpp (default)<br>10 – Main Link IN0p/n squelch detection threshold set to 160 mVpp<br>11 – Main Link IN0p/n squelch detection threshold set to 200 mVpp   | RW     |
|         | 3      | SQUELCH_ENABLE<br>0 – Main Link IN0p/n squelch detection enabled (default)<br>1 – Main Link IN0p/n squelch detection disabled  | RW     |

**Table 7. SN75DP126 Local I<sup>2</sup>C Control and Status Registers (continued)**

| ADDRESS | BIT(S) | DESCRIPTION  | ACCESS |
|---------|--------|--|--------|
| 04h     | 3      | TI_TEST. This field defaults to zero value, and should not be modified.  | RW     |
|         | 2      | LINK_TRAINING_ENABLE<br>0 – DisplayPort sink Link Training is disabled. V <sub>OD</sub> and Pre-emphasis are configured through the I <sup>2</sup> C register interface; the EQ is fixed when this bit is zero.<br>1 – DisplayPort sink Link Training is enabled (default)   | RW     |
|         | 1      | Reserved - Do not change this value  | R/W    |
| 05h     | 7      | EQ_I2C_ENABLE<br>0 – EQ settings controlled by device inputs only (default)<br>1 – EQ settings controlled by I <sup>2</sup> C register settings  | RW     |
|         | 6:4    | AEQ_L0_LANE0_SET. This field selects the EQ setting for Lane 0 when I2C_EQ_ENABLE is set, the DisplayPort sink is selected, Link Training is enabled, and the Link Training results in Level 0 pre-emphasis.<br>000 – 0 dB EQ gain (default)                      100 – 5 dB (HBR); 10 dB (HBR2)<br>001 – 1.5 dB (HBR); 3.5 dB (HBR2)              101 – 6 dB (HBR); 13 dB (HBR2)<br>010 – 3 dB (HBR); 6 dB (HBR2)                    110 – 7 dB (HBR); 15 dB (HBR2)<br>011 – 4 dB (HBR); 8 dB (HBR2)                    111 – 9 dB (HBR); 18 dB (HBR2)  | RW     |
|         | 2:0    | AEQ_L1_LANE0_SET. This field selects the EQ setting for Lane 0 when I2C_EQ_ENABLE is set, the DisplayPort sink is selected, Link Training is enabled, and the Link Training results in Level 1 pre-emphasis. This field also selects the fixed EQ setting for the following non-AEQ modes:<br><ul style="list-style-type: none"> <li>• I2C_EQ_ENABLE is set, the DisplayPort sink is selected, and Link Training is disabled</li> <li>• I2C_EQ_ENABLE is set and the TMDS sink is selected.</li> </ul> 000 – 0 dB EQ gain (default)                      100 – 5 dB (HBR); 10 dB (HBR2)<br>001 – 1.5 dB (HBR); 3.5 dB (HBR2)              101 – 6 dB (HBR); 13 dB (HBR2)<br>010 – 3 dB (HBR); 6 dB (HBR2)                    110 – 7 dB (HBR); 15 dB (HBR2)<br>011 – 4 dB (HBR); 8 dB (HBR2)                    111 – 9 dB (HBR); 18 dB (HBR2) | RW     |
|         | 6:4    | AEQ_L2_LANE0_SET. This field selects the EQ setting for Lane 0 when I2C_EQ_ENABLE is set, the DisplayPort sink is selected, Link Training is enabled, and the Link Training results in Level 2 pre-emphasis.<br>000 – 0 dB EQ gain (default)                      100 – 5 dB (HBR); 10 dB (HBR2)<br>001 – 1.5 dB (HBR); 3.5 dB (HBR2)              101 – 6 dB (HBR); 13 dB (HBR2)<br>010 – 3 dB (HBR); 6 dB (HBR2)                    110 – 7 dB (HBR); 15 dB (HBR2)<br>011 – 4 dB (HBR); 8 dB (HBR2)                    111 – 9 dB (HBR); 18 dB (HBR2)  | RW     |
| 06h     | 2:0    | AEQ_L3_LANE0_SET. This field selects the EQ setting for Lane 0 when I2C_EQ_ENABLE is set, the DisplayPort sink is selected, Link Training is enabled, and the Link Training results in Level 3 pre-emphasis.<br>000 – 0 dB EQ gain (default)                      100 – 5 dB (HBR); 10 dB (HBR2)<br>001 – 1.5 dB (HBR); 3.5 dB (HBR2)              101 – 6 dB (HBR); 13 dB (HBR2)<br>010 – 3 dB (HBR); 6 dB (HBR2)                    110 – 7 dB (HBR); 15 dB (HBR2)<br>011 – 4 dB (HBR); 8 dB (HBR2)                    111 – 9 dB (HBR); 18 dB (HBR2)  | RW     |

**Table 7. SN75DP126 Local I<sup>2</sup>C Control and Status Registers (continued)**

| ADDRESS | BIT(S) | DESCRIPTION   | ACCESS |
|---------|--------|---|--------|
| 07h     | 6:4    | AEQ_L0_LANE1_SET. This field selects the EQ setting for Lane 1 when I2C_EQ_ENABLE is set, the DisplayPort sink is selected, Link Training is enabled, and the Link Training results in Level 0 pre-emphasis.<br><br>000 – 0 dB EQ gain (default)                      100 – 5 dB (HBR); 10 dB (HBR2)<br>001 – 1.5 dB (HBR); 3.5 dB (HBR2)                      101 – 6 dB (HBR); 13 dB (HBR2)<br>010 – 3 dB (HBR); 6 dB (HBR2)                      110 – 7 dB (HBR); 15 dB (HBR2)<br>011 – 4 dB (HBR); 8 dB (HBR2)                      111 – 9 dB (HBR); 18 dB (HBR2)   | RW     |
|         | 2:0    | AEQ_L1_LANE1_SET. This field selects the EQ setting for Lane 1 when I2C_EQ_ENABLE is set, the DisplayPort sink is selected, Link Training is enabled, and the Link Training results in Level 1 pre-emphasis. This field also selects the fixed EQ setting for the following non-AEQ modes: <ul style="list-style-type: none"> <li>• I2C_EQ_ENABLE is set, the DisplayPort sink is selected, and Link Training is disabled</li> <li>• I2C_EQ_ENABLE is set and the TMDS sink is selected.</li> </ul> 000 – 0 dB EQ gain (default)                      100 – 5 dB (HBR); 10 dB (HBR2)<br>001 – 1.5 dB (HBR); 3.5 dB (HBR2)                      101 – 6 dB (HBR); 13 dB (HBR2)<br>010 – 3 dB (HBR); 6 dB (HBR2)                      110 – 7 dB (HBR); 15 dB (HBR2)<br>011 – 4 dB (HBR); 8 dB (HBR2)                      111 – 9 dB (HBR); 18 dB (HBR2) | RW     |
| 08h     | 6:4    | AEQ_L2_LANE1_SET. This field selects the EQ setting for Lane 1 when I2C_EQ_ENABLE is set, the DisplayPort sink is selected, Link Training is enabled, and the Link Training results in Level 2 pre-emphasis.<br><br>000 – 0 dB EQ gain (default)                      100 – 5 dB (HBR); 10 dB (HBR2)<br>001 – 1.5 dB (HBR); 3.5 dB (HBR2)                      101 – 6 dB (HBR); 13 dB (HBR2)<br>010 – 3 dB (HBR); 6 dB (HBR2)                      110 – 7 dB (HBR); 15 dB (HBR2)<br>011 – 4 dB (HBR); 8 dB (HBR2)                      111 – 9 dB (HBR); 18 dB (HBR2)   | RW     |
|         | 2:0    | AEQ_L3_LANE1_SET. This field selects the EQ setting for Lane 1 when I2C_EQ_ENABLE is set, the DisplayPort sink is selected, Link Training is enabled, and the Link Training results in Level 3 pre-emphasis.<br><br>000 – 0 dB EQ gain (default)                      100 – 5 dB (HBR); 10 dB (HBR2)<br>001 – 1.5 dB (HBR); 3.5 dB (HBR2)                      101 – 6 dB (HBR); 13 dB (HBR2)<br>010 – 3 dB (HBR); 6 dB (HBR2)                      110 – 7 dB (HBR); 15 dB (HBR2)<br>011 – 4 dB (HBR); 8 dB (HBR2)                      111 – 9 dB (HBR); 18 dB (HBR2)   | RW     |
| 09h     | 6:4    | AEQ_L0_LANE2_SET. This field selects the EQ setting for Lane 2 when I2C_EQ_ENABLE is set, the DisplayPort sink is selected, Link Training is enabled, and the Link Training results in Level 0 pre-emphasis.<br><br>000 – 0 dB EQ gain (default)                      100 – 5 dB (HBR); 10 dB (HBR2)<br>001 – 1.5 dB (HBR); 3.5 dB (HBR2)                      101 – 6 dB (HBR); 13 dB (HBR2)<br>010 – 3 dB (HBR); 6 dB (HBR2)                      110 – 7 dB (HBR); 15 dB (HBR2)<br>011 – 4 dB (HBR); 8 dB (HBR2)                      111 – 9 dB (HBR); 18 dB (HBR2)   | RW     |
|         | 2:0    | AEQ_L1_LANE2_SET. This field selects the EQ setting for Lane 2 when I2C_EQ_ENABLE is set, the DisplayPort sink is selected, Link Training is enabled, and the Link Training results in Level 1 pre-emphasis. This field also selects the fixed EQ setting for the following non-AEQ modes: <ul style="list-style-type: none"> <li>• I2C_EQ_ENABLE is set, the DisplayPort sink is selected, and Link Training is disabled</li> <li>• I2C_EQ_ENABLE is set and the TMDS sink is selected.</li> </ul> 000 – 0 dB EQ gain (default)                      100 – 5 dB (HBR); 10 dB (HBR2)<br>001 – 1.5 dB (HBR); 3.5 dB (HBR2)                      101 – 6 dB (HBR); 13 dB (HBR2)<br>010 – 3 dB (HBR); 6 dB (HBR2)                      110 – 7 dB (HBR); 15 dB (HBR2)<br>011 – 4 dB (HBR); 8 dB (HBR2)                      111 – 9 dB (HBR); 18 dB (HBR2) | RW     |

**Table 7. SN75DP126 Local I<sup>2</sup>C Control and Status Registers (continued)**

| ADDRESS                           | BIT(S)  | DESCRIPTION  | ACCESS                         |                                   |                                   |                                |                                |                                |                                |                                |    |
|-----------------------------------|---|--|--------------------------------|-----------------------------------|-----------------------------------|--------------------------------|--------------------------------|--------------------------------|--------------------------------|--------------------------------|----|
| 0Ah                               | 6:4   | <p>AEQ_L2_LANE2_SET. This field selects the EQ setting for Lane 2 when I2C_EQ_ENABLE is set, the DisplayPort sink is selected, Link Training is enabled, and the Link Training results in Level 2 pre-emphasis.</p> <table border="0"> <tr> <td>000 – 0 dB EQ gain (default)</td> <td>100 – 5 dB (HBR); 10 dB (HBR2)</td> </tr> <tr> <td>001 – 1.5 dB (HBR); 3.5 dB (HBR2)</td> <td>101 – 6 dB (HBR); 13 dB (HBR2)</td> </tr> <tr> <td>010 – 3 dB (HBR); 6 dB (HBR2)</td> <td>110 – 7 dB (HBR); 15 dB (HBR2)</td> </tr> <tr> <td>011 – 4 dB (HBR); 8 dB (HBR2)</td> <td>111 – 9 dB (HBR); 18 dB (HBR2)</td> </tr> </table> | 000 – 0 dB EQ gain (default)   | 100 – 5 dB (HBR); 10 dB (HBR2)    | 001 – 1.5 dB (HBR); 3.5 dB (HBR2) | 101 – 6 dB (HBR); 13 dB (HBR2) | 010 – 3 dB (HBR); 6 dB (HBR2)  | 110 – 7 dB (HBR); 15 dB (HBR2) | 011 – 4 dB (HBR); 8 dB (HBR2)  | 111 – 9 dB (HBR); 18 dB (HBR2) | RW |
|                                   | 000 – 0 dB EQ gain (default)  | 100 – 5 dB (HBR); 10 dB (HBR2)   |                                |                                   |                                   |                                |                                |                                |                                |                                |    |
| 001 – 1.5 dB (HBR); 3.5 dB (HBR2) | 101 – 6 dB (HBR); 13 dB (HBR2)  |  |                                |                                   |                                   |                                |                                |                                |                                |                                |    |
| 010 – 3 dB (HBR); 6 dB (HBR2)     | 110 – 7 dB (HBR); 15 dB (HBR2)  |  |                                |                                   |                                   |                                |                                |                                |                                |                                |    |
| 011 – 4 dB (HBR); 8 dB (HBR2)     | 111 – 9 dB (HBR); 18 dB (HBR2)  |  |                                |                                   |                                   |                                |                                |                                |                                |                                |    |
| 2:0                               | <p>AEQ_L3_LANE2_SET. This field selects the EQ setting for Lane 2 when I2C_EQ_ENABLE is set, the DisplayPort sink is selected, Link Training is enabled, and the Link Training results in Level 3 pre-emphasis.</p> <table border="0"> <tr> <td>000 – 0 dB EQ gain (default)</td> <td>100 – 5 dB (HBR); 10 dB (HBR2)</td> </tr> <tr> <td>001 – 1.5 dB (HBR); 3.5 dB (HBR2)</td> <td>101 – 6 dB (HBR); 13 dB (HBR2)</td> </tr> <tr> <td>010 – 3 dB (HBR); 6 dB (HBR2)</td> <td>110 – 7 dB (HBR); 15 dB (HBR2)</td> </tr> <tr> <td>011 – 4 dB (HBR); 8 dB (HBR2)</td> <td>111 – 9 dB (HBR); 18 dB (HBR2)</td> </tr> </table>  | 000 – 0 dB EQ gain (default)   | 100 – 5 dB (HBR); 10 dB (HBR2) | 001 – 1.5 dB (HBR); 3.5 dB (HBR2) | 101 – 6 dB (HBR); 13 dB (HBR2)    | 010 – 3 dB (HBR); 6 dB (HBR2)  | 110 – 7 dB (HBR); 15 dB (HBR2) | 011 – 4 dB (HBR); 8 dB (HBR2)  | 111 – 9 dB (HBR); 18 dB (HBR2) | RW                             |    |
| 000 – 0 dB EQ gain (default)      | 100 – 5 dB (HBR); 10 dB (HBR2)  |  |                                |                                   |                                   |                                |                                |                                |                                |                                |    |
| 001 – 1.5 dB (HBR); 3.5 dB (HBR2) | 101 – 6 dB (HBR); 13 dB (HBR2)  |  |                                |                                   |                                   |                                |                                |                                |                                |                                |    |
| 010 – 3 dB (HBR); 6 dB (HBR2)     | 110 – 7 dB (HBR); 15 dB (HBR2)  |  |                                |                                   |                                   |                                |                                |                                |                                |                                |    |
| 011 – 4 dB (HBR); 8 dB (HBR2)     | 111 – 9 dB (HBR); 18 dB (HBR2)  |  |                                |                                   |                                   |                                |                                |                                |                                |                                |    |
| 0Bh                               | 6:4   | <p>AEQ_L0_LANE3_SET. This field selects the EQ setting for Lane 3 when I2C_EQ_ENABLE is set, the DisplayPort sink is selected, Link Training is enabled, and the Link Training results in Level 0 pre-emphasis.</p> <table border="0"> <tr> <td>000 – 0 dB EQ gain (default)</td> <td>100 – 5 dB (HBR); 10 dB (HBR2)</td> </tr> <tr> <td>001 – 1.5 dB (HBR); 3.5 dB (HBR2)</td> <td>101 – 6 dB (HBR); 13 dB (HBR2)</td> </tr> <tr> <td>010 – 3 dB (HBR); 6 dB (HBR2)</td> <td>110 – 7 dB (HBR); 15 dB (HBR2)</td> </tr> <tr> <td>011 – 4 dB (HBR); 8 dB (HBR2)</td> <td>111 – 9 dB (HBR); 18 dB (HBR2)</td> </tr> </table> | 000 – 0 dB EQ gain (default)   | 100 – 5 dB (HBR); 10 dB (HBR2)    | 001 – 1.5 dB (HBR); 3.5 dB (HBR2) | 101 – 6 dB (HBR); 13 dB (HBR2) | 010 – 3 dB (HBR); 6 dB (HBR2)  | 110 – 7 dB (HBR); 15 dB (HBR2) | 011 – 4 dB (HBR); 8 dB (HBR2)  | 111 – 9 dB (HBR); 18 dB (HBR2) | RW |
|                                   | 000 – 0 dB EQ gain (default)  | 100 – 5 dB (HBR); 10 dB (HBR2)   |                                |                                   |                                   |                                |                                |                                |                                |                                |    |
| 001 – 1.5 dB (HBR); 3.5 dB (HBR2) | 101 – 6 dB (HBR); 13 dB (HBR2)  |  |                                |                                   |                                   |                                |                                |                                |                                |                                |    |
| 010 – 3 dB (HBR); 6 dB (HBR2)     | 110 – 7 dB (HBR); 15 dB (HBR2)  |  |                                |                                   |                                   |                                |                                |                                |                                |                                |    |
| 011 – 4 dB (HBR); 8 dB (HBR2)     | 111 – 9 dB (HBR); 18 dB (HBR2)  |  |                                |                                   |                                   |                                |                                |                                |                                |                                |    |
| 2:0                               | <p>AEQ_L1_LANE3_SET. This field selects the EQ setting for Lane 3 when I2C_EQ_ENABLE is set, the DisplayPort sink is selected, Link Training is enabled, and the Link Training results in Level 1 pre-emphasis. This field also selects the fixed EQ setting for the following non-AEQ mode:</p> <ul style="list-style-type: none"> <li>• I2C_EQ_ENABLE is set, the DisplayPort sink is selected, and Link Training is disabled</li> </ul> <table border="0"> <tr> <td>000 – 0 dB EQ gain (default)</td> <td>100 – 5 dB (HBR); 10 dB (HBR2)</td> </tr> <tr> <td>001 – 1.5 dB (HBR); 3.5 dB (HBR2)</td> <td>101 – 6 dB (HBR); 13 dB (HBR2)</td> </tr> <tr> <td>010 – 3 dB (HBR); 6 dB (HBR2)</td> <td>110 – 7 dB (HBR); 15 dB (HBR2)</td> </tr> <tr> <td>011 – 4 dB (HBR); 8 dB (HBR2)</td> <td>111 – 9 dB (HBR); 18 dB (HBR2)</td> </tr> </table> | 000 – 0 dB EQ gain (default)   | 100 – 5 dB (HBR); 10 dB (HBR2) | 001 – 1.5 dB (HBR); 3.5 dB (HBR2) | 101 – 6 dB (HBR); 13 dB (HBR2)    | 010 – 3 dB (HBR); 6 dB (HBR2)  | 110 – 7 dB (HBR); 15 dB (HBR2) | 011 – 4 dB (HBR); 8 dB (HBR2)  | 111 – 9 dB (HBR); 18 dB (HBR2) | RW                             |    |
| 000 – 0 dB EQ gain (default)      | 100 – 5 dB (HBR); 10 dB (HBR2)  |  |                                |                                   |                                   |                                |                                |                                |                                |                                |    |
| 001 – 1.5 dB (HBR); 3.5 dB (HBR2) | 101 – 6 dB (HBR); 13 dB (HBR2)  |  |                                |                                   |                                   |                                |                                |                                |                                |                                |    |
| 010 – 3 dB (HBR); 6 dB (HBR2)     | 110 – 7 dB (HBR); 15 dB (HBR2)  |  |                                |                                   |                                   |                                |                                |                                |                                |                                |    |
| 011 – 4 dB (HBR); 8 dB (HBR2)     | 111 – 9 dB (HBR); 18 dB (HBR2)  |  |                                |                                   |                                   |                                |                                |                                |                                |                                |    |
| 0Ch                               | 6:4   | <p>AEQ_L2_LANE3_SET. This field selects the EQ setting for Lane 3 when I2C_EQ_ENABLE is set, the DisplayPort sink is selected, Link Training is enabled, and the Link Training results in Level 2 pre-emphasis.</p> <table border="0"> <tr> <td>000 – 0 dB EQ gain (default)</td> <td>100 – 5 dB (HBR); 10 dB (HBR2)</td> </tr> <tr> <td>001 – 1.5 dB (HBR); 3.5 dB (HBR2)</td> <td>101 – 6 dB (HBR); 13 dB (HBR2)</td> </tr> <tr> <td>010 – 3 dB (HBR); 6 dB (HBR2)</td> <td>110 – 7 dB (HBR); 15 dB (HBR2)</td> </tr> <tr> <td>011 – 4 dB (HBR); 8 dB (HBR2)</td> <td>111 – 9 dB (HBR); 18 dB (HBR2)</td> </tr> </table> | 000 – 0 dB EQ gain (default)   | 100 – 5 dB (HBR); 10 dB (HBR2)    | 001 – 1.5 dB (HBR); 3.5 dB (HBR2) | 101 – 6 dB (HBR); 13 dB (HBR2) | 010 – 3 dB (HBR); 6 dB (HBR2)  | 110 – 7 dB (HBR); 15 dB (HBR2) | 011 – 4 dB (HBR); 8 dB (HBR2)  | 111 – 9 dB (HBR); 18 dB (HBR2) | RW |
|                                   | 000 – 0 dB EQ gain (default)  | 100 – 5 dB (HBR); 10 dB (HBR2)   |                                |                                   |                                   |                                |                                |                                |                                |                                |    |
| 001 – 1.5 dB (HBR); 3.5 dB (HBR2) | 101 – 6 dB (HBR); 13 dB (HBR2)  |  |                                |                                   |                                   |                                |                                |                                |                                |                                |    |
| 010 – 3 dB (HBR); 6 dB (HBR2)     | 110 – 7 dB (HBR); 15 dB (HBR2)  |  |                                |                                   |                                   |                                |                                |                                |                                |                                |    |
| 011 – 4 dB (HBR); 8 dB (HBR2)     | 111 – 9 dB (HBR); 18 dB (HBR2)  |  |                                |                                   |                                   |                                |                                |                                |                                |                                |    |
| 2:0                               | <p>AEQ_L3_LANE3_SET. This field selects the EQ setting for Lane 3 when I2C_EQ_ENABLE is set, the DisplayPort sink is selected, Link Training is enabled, and the Link Training results in Level 3 pre-emphasis.</p> <table border="0"> <tr> <td>000 – 0 dB EQ gain (default)</td> <td>100 – 5 dB (HBR); 10 dB (HBR2)</td> </tr> <tr> <td>001 – 1.5 dB (HBR); 3.5 dB (HBR2)</td> <td>101 – 6 dB (HBR); 13 dB (HBR2)</td> </tr> <tr> <td>010 – 3 dB (HBR); 6 dB (HBR2)</td> <td>110 – 7 dB (HBR); 15 dB (HBR2)</td> </tr> <tr> <td>011 – 4 dB (HBR); 8 dB (HBR2)</td> <td>111 – 9 dB (HBR); 18 dB (HBR2)</td> </tr> </table>  | 000 – 0 dB EQ gain (default)   | 100 – 5 dB (HBR); 10 dB (HBR2) | 001 – 1.5 dB (HBR); 3.5 dB (HBR2) | 101 – 6 dB (HBR); 13 dB (HBR2)    | 010 – 3 dB (HBR); 6 dB (HBR2)  | 110 – 7 dB (HBR); 15 dB (HBR2) | 011 – 4 dB (HBR); 8 dB (HBR2)  | 111 – 9 dB (HBR); 18 dB (HBR2) | RW                             |    |
| 000 – 0 dB EQ gain (default)      | 100 – 5 dB (HBR); 10 dB (HBR2)  |  |                                |                                   |                                   |                                |                                |                                |                                |                                |    |
| 001 – 1.5 dB (HBR); 3.5 dB (HBR2) | 101 – 6 dB (HBR); 13 dB (HBR2)  |  |                                |                                   |                                   |                                |                                |                                |                                |                                |    |
| 010 – 3 dB (HBR); 6 dB (HBR2)     | 110 – 7 dB (HBR); 15 dB (HBR2)  |  |                                |                                   |                                   |                                |                                |                                |                                |                                |    |
| 011 – 4 dB (HBR); 8 dB (HBR2)     | 111 – 9 dB (HBR); 18 dB (HBR2)  |  |                                |                                   |                                   |                                |                                |                                |                                |                                |    |

**Table 7. SN75DP126 Local I<sup>2</sup>C Control and Status Registers (continued)**

| ADDRESS   | BIT(S) | DESCRIPTION   | ACCESS |
|-----------|--------|---|--------|
| 15h       | 4:3    | <p>DP_BOOST. Controls the output pre-emphasis amplitude when the DisplayPort sink is selected; allows to reduce or increase all pre-emphasis settings by ~10%. Setting this field will impact V<sub>OD</sub> when pre-emphasis is disabled.</p> <p>This setting also impacts the output in TMDS mode for the DisplayPort sink connection when the DisplayPort sink CAD_SNK input is high.</p> <p>00 – Pre-emphasis reduced by ~10%; V<sub>OD</sub> reduced by 10% if pre-emphasis is disabled.</p> <p>01 – Pre-emphasis nominal (default)</p> <p>10 – Pre-emphasis increased by ~10%; V<sub>OD</sub> increased by 10% if pre-emphasis is disabled.</p> <p>11 – Reserved</p> | RW     |
|           | 2      | <p>DP_TMDS_VOD. Sets the target output swing in TMDS mode when the DisplayPort sink is selected, where CAD_SNK input is high.</p> <p>0 – Low TMDS output swing for DisplayPort sink channel (default)</p> <p>1 – High TMDS output swing for DisplayPort sink channel</p>  | RW     |
|           | 1:0    | <p>DP_TMDS_VPRE. Controls the output pre-emphasis in TMDS mode when the DisplayPort sink is selected, where CAD_SNK input is high.</p> <p>00 – No TMDS pre-emphasis for DisplayPort sink channel (default)</p> <p>01 – Low TMDS pre-emphasis for DisplayPort sink channel</p> <p>10 – High TMDS pre-emphasis for DisplayPort sink channel</p> <p>11 – Reserved</p>  | RW     |
| 17h       | 3      | <p>DP_HPD_TEST_MODE</p> <p>0 – Normal HPD operating mode. (default)</p> <p>1 – DisplayPort sink compliance test mode. DP_HPD_SNK is pulled high internally, the TMDS_HPD_SNK is pulled low internally, and the HPD_SRC output is driven high and the Main Link is activated depending on the squelch setting.</p>   | RW     |
|           | 1      | <p>CAD_OUTPUT_INVERT</p> <p>0 – CAD_SRC output high means TMDS cable adapter detected when the DisplayPort sink is selected (default)</p> <p>1 – CAD_SRC output low means TMDS cable adapter detected when the DisplayPort sink is selected</p>   | RW     |
|           | 0      | <p>CAD_TEST_MODE</p> <p>0 – Normal CAD mode. CAD_SRC reflects the status of CAD_SNK, based on the value of CAD_OUTPUT_INVERT, when the DisplayPort sink is selected (default)</p> <p>1 – Test mode. CAD_SRC indicates TMDS mode when the DisplayPort sink is selected, depending on the value of CAD_OUTPUT_INVERT; CAD_SNK input is ignored. This mode allows execution of certain tests on SN75DP126 without a connected TMDS display sink.</p>   | RW     |
| 18h       | 3:2    | <p>HDMI/DVI_PRE</p> <p>00 – 0 dB Pre-emphasis applied to the HDMI/DVI sink TMDS output</p> <p>01 – Reserved</p> <p>10 – Reserved</p> <p>11 – 2 dB Pre-emphasis applied to the HDMI/DVI sink TMDS output</p>   | RW     |
| 19h – 1Ah | 7:0    | TI_TEST. These registers shall not be modified.   | RW     |
| 1Bh       | 7      | I2C_SOFT_RESET. Writing a one to this register resets all I <sup>2</sup> C registers to default values. Writing a zero to this register has no effect. Reads from this register return zero.  | WO     |
|           | 6      | DPCD_RESET. Writing a one to this register resets the DPCD register bits (corresponding to DPCD addresses 103h – 10Fh). Writing a zero to this register has no effect. Reads from this register return zero.  | WO     |
| 1Ch       | 3:0    | DPCD_ADDR_HIGH. This value maps to bits 19:16 of the 20-bit DPCD register address accessed through the DPCD_DATA register.  | RW     |
| 1Dh       | 7:0    | DPCD_ADDR_MID. This value maps to bits 15:8 of the 20-bit DPCD register address accessed through the DPCD_DATA register.  | RW     |
| 1Eh       | 7:0    | DPCD_ADDR_LOW. This value maps to bits 7:0 of the 20-bit DPCD register address accessed through the DPCD_DATA register.   | RW     |

**Table 7. SN75DP126 Local I<sup>2</sup>C Control and Status Registers (continued)**

| ADDRESS   | BIT(S) | DESCRIPTION  | ACCESS |
|-----------|--------|--|--------|
| 1Fh       | 7:0    | DPCD_DATA. This register contains the data to write into or read from the DPCD register addressed by DPCD_ADDR_HIGH, DPCD_ADDR_MID, and DPCD_ADDR_LOW. | RW     |
| 20h       | 7:1    | DEV_ID_REV. This field identifies the device and revision.<br>0000000 – SN75DP126 Revision 0   | RO     |
|           | 0      | BIT_INVERT. The value read from this field is the inverse of that written.<br>Default read value is '1'.   | RW     |
| 21h       | 7:0    | TI_TEST. These registers shall not be modified.  | RW     |
| 22h – 27h | 7:0    | TI_TEST_RESERVED. These read only registers are reserved for test; writes are ignored.   | RO     |

## 9 Application and Implementation

### NOTE

Information in the following applications sections is not part of the TI component specification, and TI does not warrant its accuracy or completeness. TI's customers are responsible for determining suitability of components for their purposes. Customers should validate and test their design implementation to confirm system functionality.

### 9.1 Application Information

The SN75DP126 switches one Dual-Mode DisplayPort (DP++) input to one DP++ sink output or one HDMI/DVI sink output. The HDMI/DVI output has a built-in level translator compliant with DVI 1.0 and HDMI 1.4b and supports resolutions greater than 1920 x 1440 and HDTV deep color at 1080p.

### 9.2 Typical Application

The SN75DP126 can be used in a dongle implementation to switch from one DP++ Source to one DP++ Sink or one HDMI/DVI Sink.

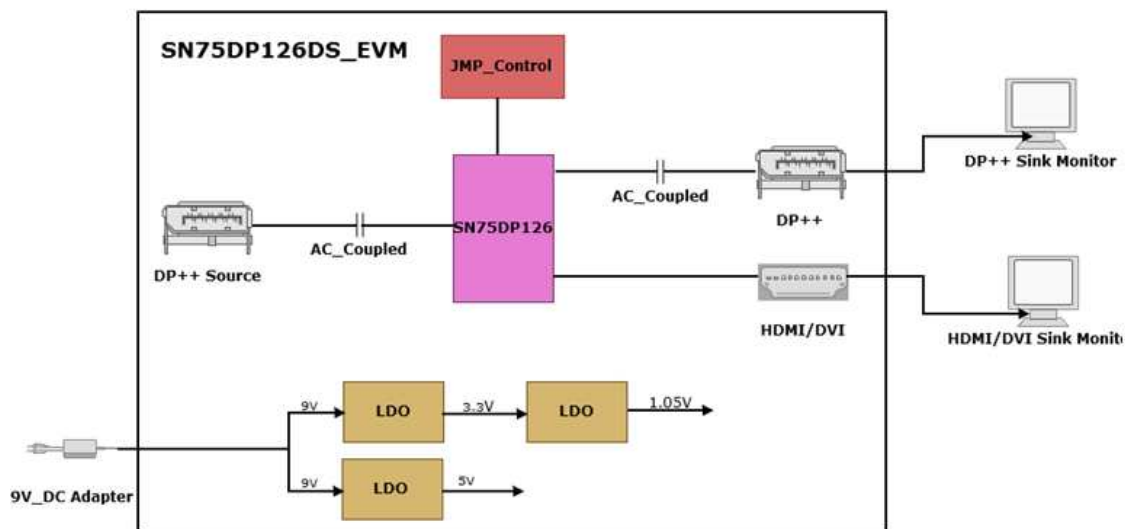

Figure 27. Typical Dongle Implementation

#### 9.2.1 Design Requirements

The design requirements for this application are listed in [Table 8](#).

Table 8. Design Requirements

| Design Parameter | Example Value |
|------------------|---------------|
| Source           | DP++          |
| Sink             | DP++          |
| Sink Priority    | High (DP)     |
| OVS              | Low           |
| PRE              | Low           |
| EQ               | Low           |
| SLEW             | Low           |
| VCC              | 9 V           |



## 9.2.2 Detailed Design Procedure

### 9.2.2.1 AC Coupling Capacitors

The DP link is an AC-coupled interface. AC coupling capacitors must be placed between the Source and the DP126.

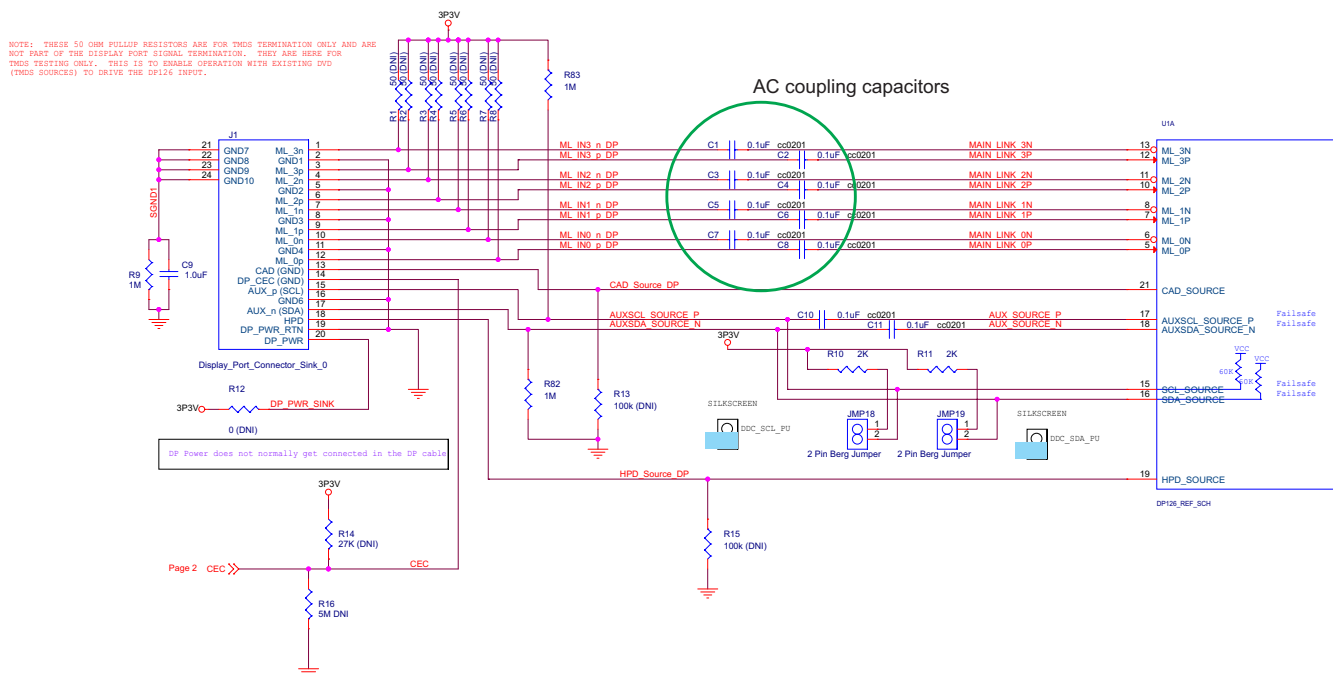

Figure 28. Source-to-DP126 AC Coupling Capacitors

AC coupling capacitors are required from the DP126 output to the DP Sink as well.

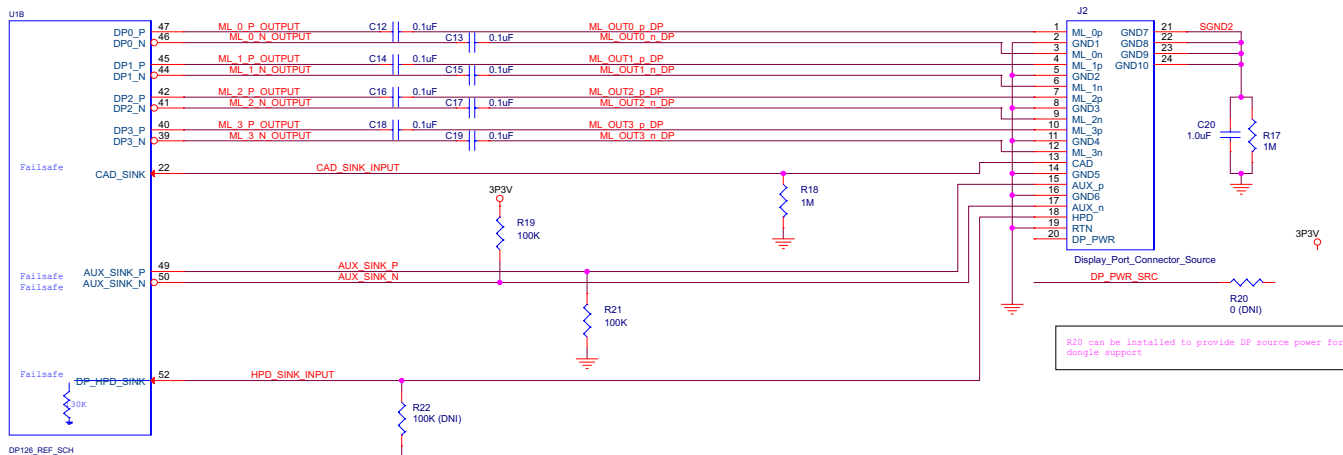

Figure 29. DP126 Output to the DP Sink AC Coupling Capacitors

SN75DP126

ZHCS794B –FEBRUARY 2012–REVISED AUGUST 2015

www.ti.com.cn

9.2.2.2 Configuration Options

It is recommended to leave place holders on the Configuration I/O for further fine tuning.

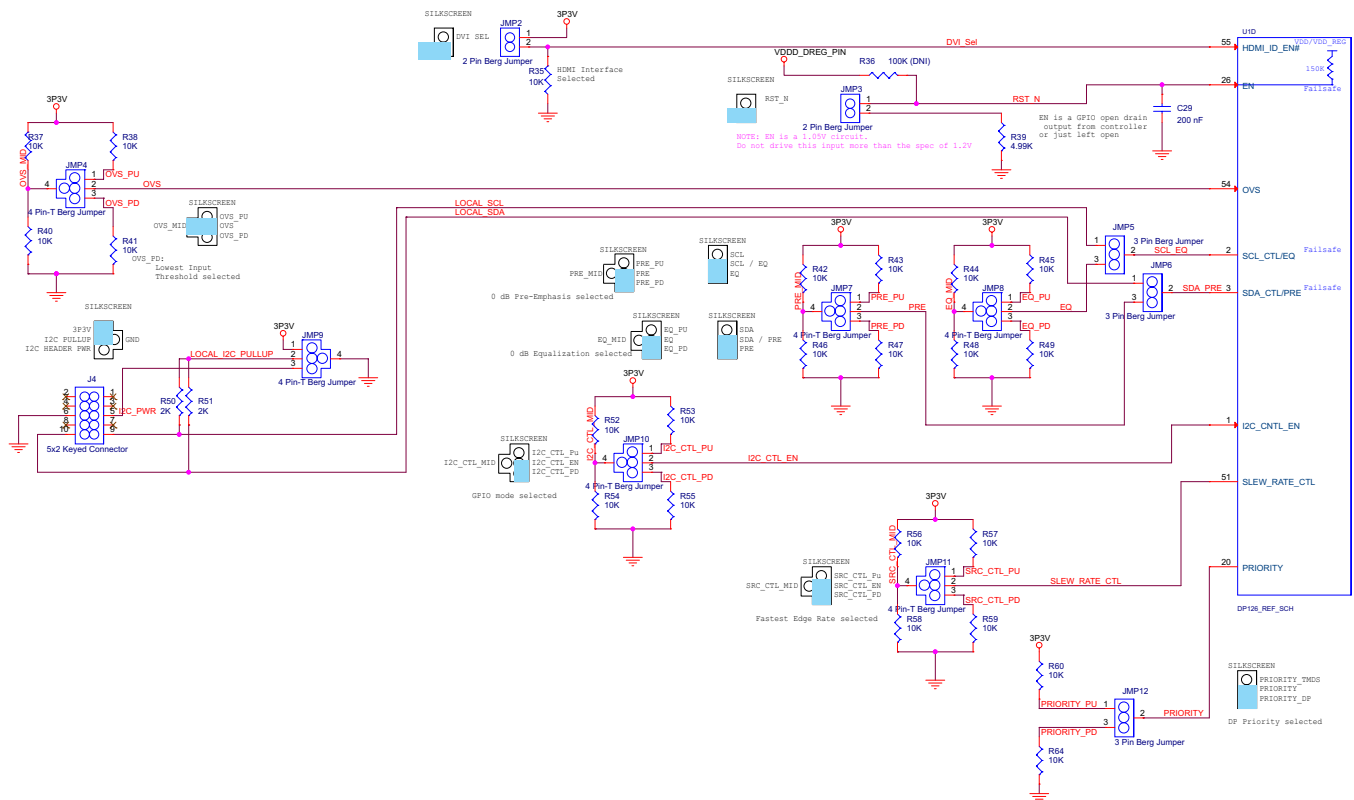

Figure 30. Configuration Options

9.2.2.3 Dual Layout for Single or Dual Power Supply

The SN75DP126DS requires dual power supply whereas the DP126SS requires only one power supply. The design can have options to use either one with minor hardware changes

DP126SS:  
 Vcc (3.3V) is connected to pins 4, 14, 33, 43  
 Pin 23 (VDD\_DREG) is an internal regulator requiring a 1uF cap to ground for bypassing  
 (DO NOT connect Pin 23 to external power source)

DP126DS:  
 Vcc (3.3V) is connected to pins 4 only  
 Vdd (1.05V) is connected to pins 14, 33, 43  
 Vdd (1.05V) is connected to 23 (VDD\_DREG) with bypass

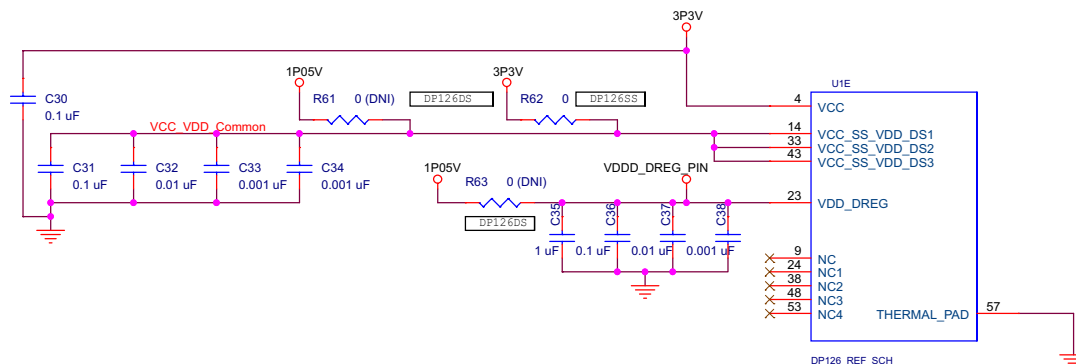

Figure 31. Power Supply Layout

### 9.2.3 Application Curves

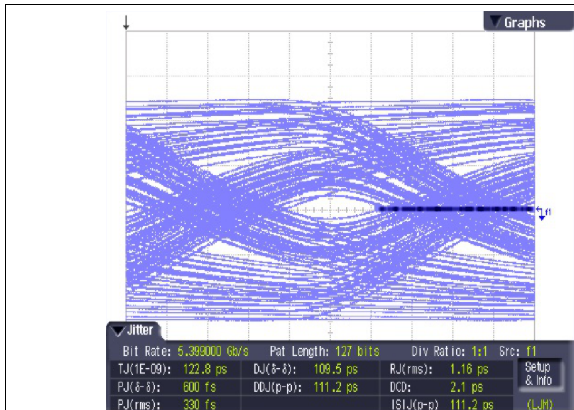

Figure 32. Main Link Input with 22-inch Trace; DisplayPort Sink

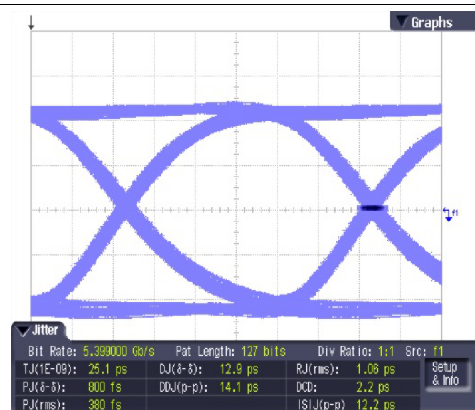

Figure 33. SN75DP126 Output; 22-inch Input Trace; 15 dB EQ Setting; DP Sink

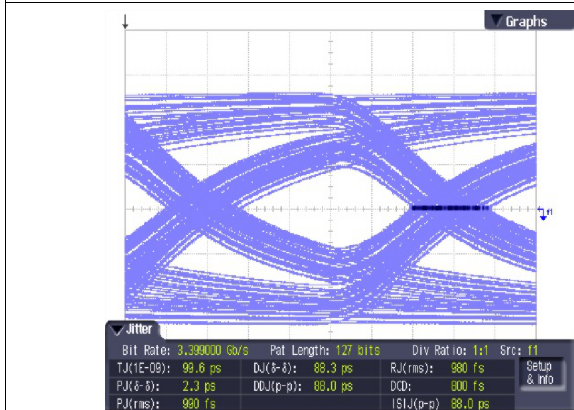

Figure 34. Main Link Input with 22-inch Trace; TMD5 Sink

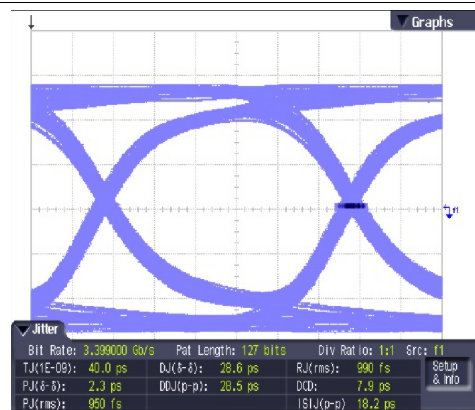

Figure 35. SN75DP126 Output; 22-inch Input Trace; 15 dB EQ Setting; TMD5 Sink

## 10 Power Supply Recommendations

### 10.1 Analog vs Digital vs High Power

Digital ground and power carry the RF energy that needs to be contained, so it is best to isolate it from any other power and ground, either analog, high power, or other unrelated trace. If noise from the microcomputer or any other circuit gets on an isolated ground, it can be returned by careful placement of a small RF capacitor in the 470 – 1000 pF range. Choosing the location of the capacitor is by trial and error, and is best done in the screen room.

### 10.2 Analog Power-Supply Pins and Analog Reference Voltages

The reference voltage of an analog-to-digital (A/D) converter integrated into a microcomputer does supply a very small amount of clocked current; however, it is not enough to be concerned about from a noise-emissions standpoint. Most applications have the analog  $V_{SS}$  /  $V_{CC}$  tied to the digital  $V_{SS1}$  /  $V_{CC1}$  pins, which does not change significantly the noise characteristics of the A/D nor the radiated emissions

## 11 Layout

### 11.1 Layout Guidelines

- Decoupling with small current loops is recommended.
- It is recommended to place the de-coupling cap as close as possible to the device and on the same side of the PCB.
- Choose the capacitor such that the resonant frequency of the capacitor does not align closely with 5.4 GHz.
- Also provide several GND vias to the thermal pad to minimize the area of current loops.

#### 11.1.1 Layer Stack

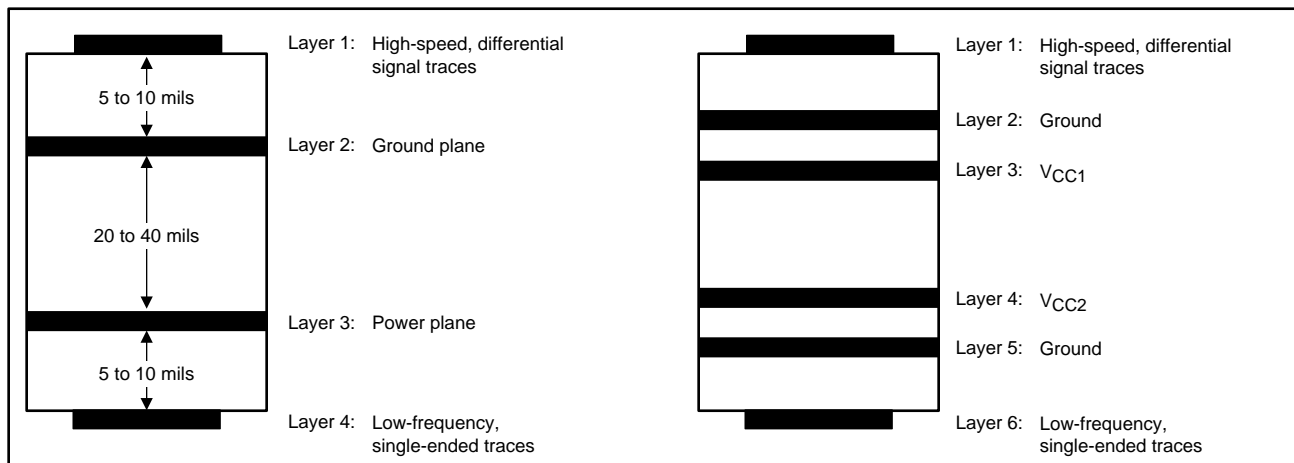

**Figure 36. Recommended 4- or 6-Layer (0.062") Stack for a Receiver PCB Design**

Routing the high-speed differential signal traces on the top layer avoids the use of vias (and the introduction of their inductances) and allows for clean interconnects from the DisplayPort connectors to the repeater inputs and from the repeater output to the subsequent receiver circuit.

Placing a solid ground plane next to the high-speed signal layer establishes controlled impedance for transmission line interconnects and provides an excellent low-inductance path for the return current flow.

Placing the power plane next to the ground plane creates additional high-frequency bypass capacitance.

Routing the fast-edged control signals on the bottom layer by prevents them from cross-talking into the high-speed signal traces and minimizes EMI.

**Layout Guidelines (continued)**

If the receiver requires a supply voltage different from the one of the repeater, add a second power/ground plane system to the stack to keep it symmetrical. This makes the stack mechanically stable and prevents it from warping. Also, the power and ground plane of each power system can be placed closer together, thus increasing the high-frequency bypass capacitance significantly. Finally, a second power/ground system provides added isolation between the signal layers.

**11.1.2 Power Plane Do's and Don'ts for Four-Layer Boards**

Reducing noise in four-layer board configurations is of paramount concern. The following guidelines should maintain the advantages gained in the four-layer board layout.

- Pay utmost attention to how the holes and cutouts in the planes are done. They break up the plane and, therefore, cause increased loop areas (see A and B in [Figure 37](#)).
- Avoid buried traces in the ground plane. If you have to use them, put them in the +V plane.
- When making through holes for 100-mil-center-spacing leads in the plane, place a small trace between each pin. Breaking up the plane with a row of holes is much better than having a long slot (see C and D in [Figure 37](#)).
- When splitting up the ground plane to make a digital and power ground for example, make sure that the signals connected to the microcomputer are still located entirely over the digital ground. Extending signal traces beyond the power ground is detrimental because the power ground does not work to reduce the loop area for digital noise signals.

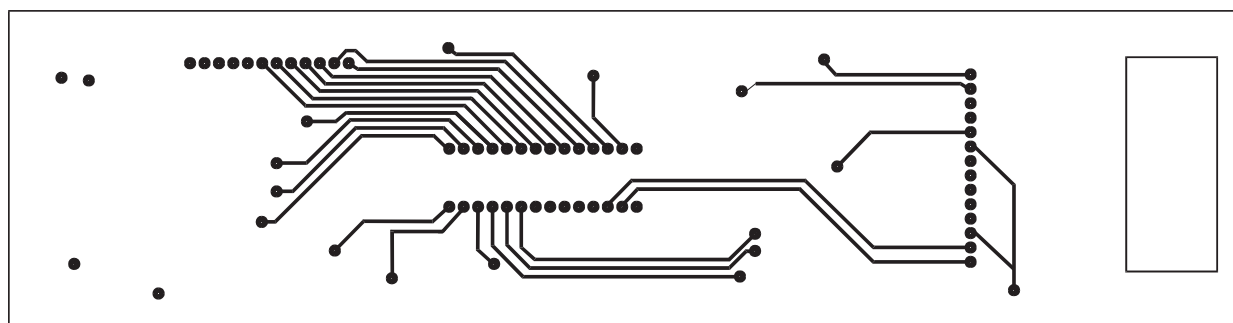

Ground Plane

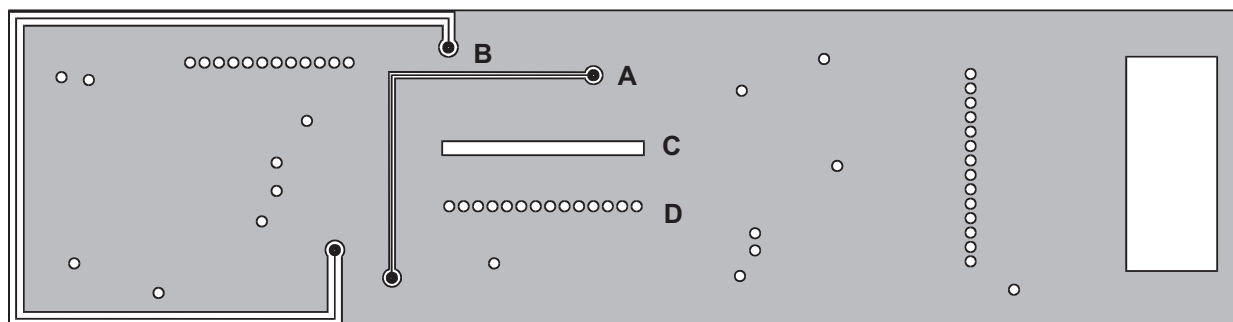

- |   |   |
|---|---|
| <b>A</b> POOR – Buried trace cuts ground plane into two parts   | <b>C</b> POOR – Slot formed by 100-mil spacing cuts up ground plane and focuses slot antenna radiation into that connection |
| <b>B</b> BETTER – Buried trace around the perimeter<br>Best solution is no trace at all in the ground plane | <b>D</b> BETTER – Ground plane extends between 100-mil centers  |

**Figure 37. Four-Layer Board Layout Considerations**

## Layout Guidelines (continued)

### 11.1.3 Differential Traces

Guidelines for routing PCB traces are necessary when trying to maintain signal integrity and lower EMI. Although there seems to be an endless number of precautions to be taken, this section provides only a few main recommendations as layout guidance.

1. Reduce intra-pair skew in a differential trace by introducing small meandering corrections at the point of mismatch.
2. Reduce inter-pair skew, caused by component placement and IC pinouts, by making larger meandering correction along the signal path. Use chamfered corners with a length-to-trace width ratio of between 3 and 5. The distance between bends should be 8 to 10 times the trace width.
3. Use 45 degree bends (chamfered corners), instead of right-angle (90°) bends. Right-angle bends increase the effective trace width, which changes the differential trace impedance creating large discontinuities. A 45° bend is seen as a smaller discontinuity.
4. When routing around an object, route both trace of a pair in parallel. Splitting the traces changes the line-to-line spacing, thus causing the differential impedance to change and discontinuities to occur.
5. Place passive components within the signal path, such as source-matching resistors or ac-coupling capacitors, next to each other. Routing as in case a) creates wider trace spacing than in b), the resulting discontinuity, however, is limited to a far narrower area.
6. When routing traces next to a via or between an array of vias, make sure that the via clearance section does not interrupt the path of the return current on the ground plane below.
7. Avoid metal layers and traces underneath or between the pads off the DisplayPort connectors for better impedance matching. Otherwise they will cause the differential impedance to drop below 75  $\Omega$  and fail the board during TDR testing.
8. Use the smallest size possible for signal trace vias and DisplayPort connector pads as they have less impact on the 100  $\Omega$  differential impedance. Large vias and pads can cause the impedance to drop below 85  $\Omega$ .
9. Use solid power and ground planes for 100  $\Omega$  impedance control and minimum power noise.
10. For 100  $\Omega$  differential impedance, use the smallest trace spacing possible, which is usually specified by the PCB vendor.
11. Keep the trace length between the DisplayPort connector and the DisplayPort device as short as possible to minimize attenuation.
12. Use good DisplayPort connectors whose impedances meet the specifications.
13. Place bulk capacitors (for example, 10  $\mu\text{F}$ ) close to power sources, such as voltage regulators or where the power is supplied to the PCB.
14. Place smaller 0.1  $\mu\text{F}$  or 0.01  $\mu\text{F}$  capacitors at the device.



## 11.2 Layout Example

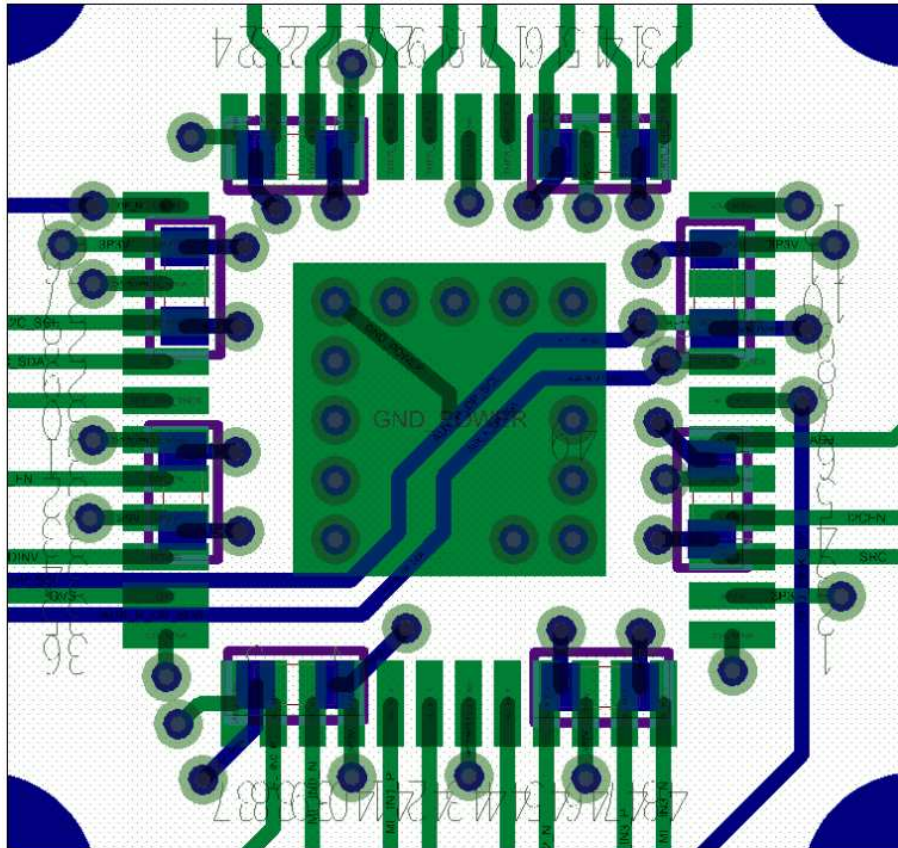

Figure 38. Thermal PAD Grounding

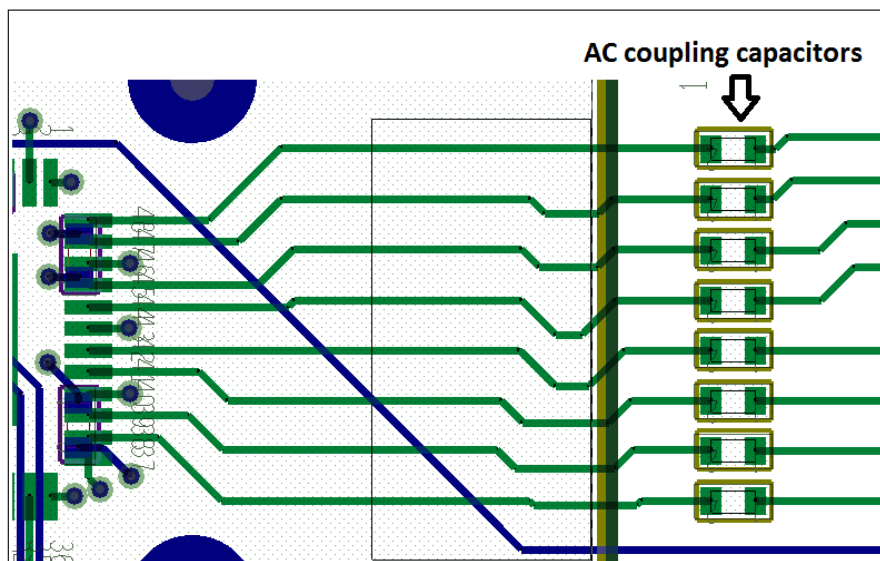

Figure 39. AC Capacitors Placement and Routing Example

SN75DP126

ZHCS794B –FEBRUARY 2012–REVISED AUGUST 2015

www.ti.com.cn

Layout Example (continued)

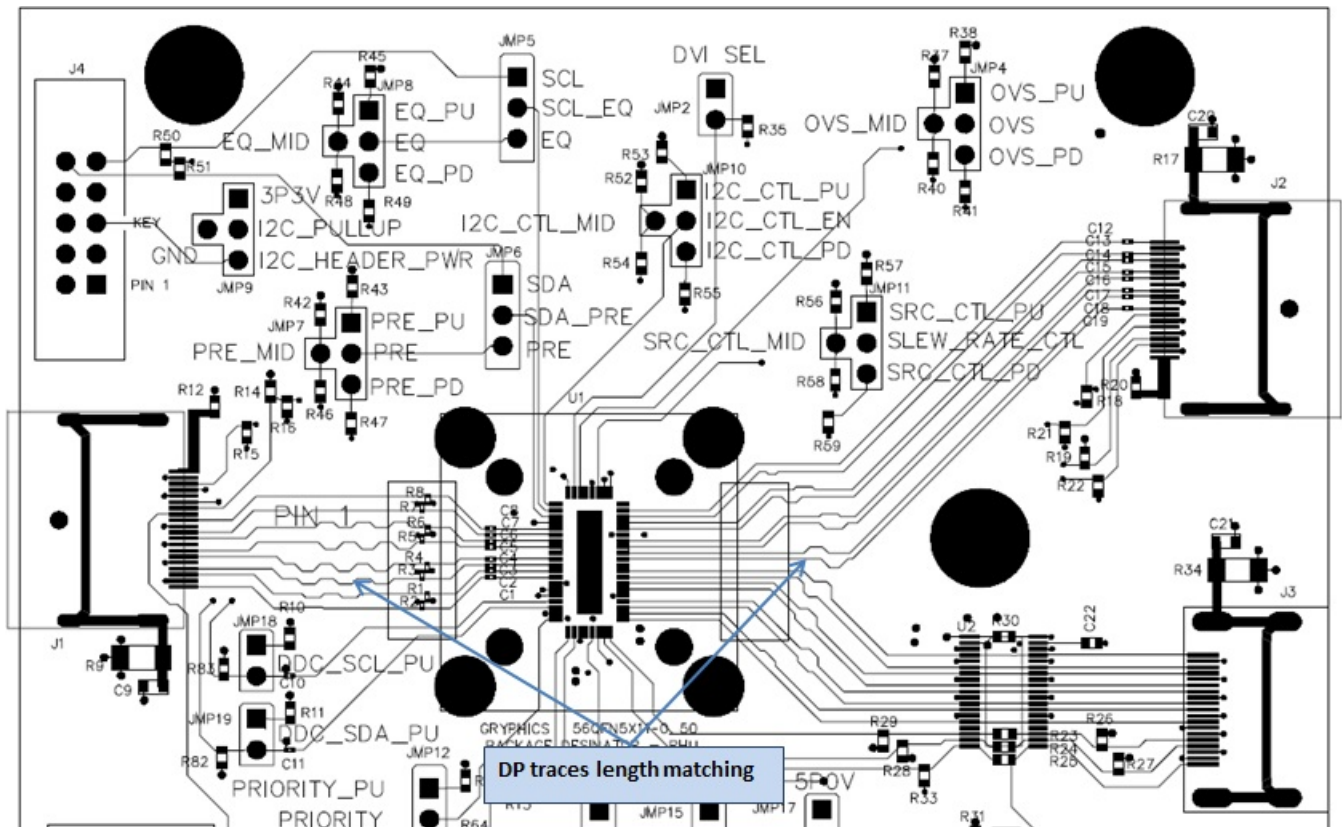

Figure 40. SN75DP126 Layout



## 12 器件和文档支持

### 12.1 社区资源

The following links connect to TI community resources. Linked contents are provided "AS IS" by the respective contributors. They do not constitute TI specifications and do not necessarily reflect TI's views; see TI's [Terms of Use](#).

**TI E2E™ Online Community** *TI's Engineer-to-Engineer (E2E) Community*. Created to foster collaboration among engineers. At [e2e.ti.com](http://e2e.ti.com), you can ask questions, share knowledge, explore ideas and help solve problems with fellow engineers.

**Design Support** *TI's Design Support* Quickly find helpful E2E forums along with design support tools and contact information for technical support.

### 12.2 商标

E2E is a trademark of Texas Instruments.

显示端口 is a trademark of VESA Standards Association.

All other trademarks are the property of their respective owners.

### 12.3 静电放电警告



这些装置包含有限的内置 ESD 保护。存储或装卸时，应将导线一起截短或将装置放置于导电泡棉中，以防止 MOS 门极遭受静电损伤。

### 12.4 Glossary

[SLYZ022](#) — *TI Glossary*.

This glossary lists and explains terms, acronyms, and definitions.

## 13 机械、封装和可订购信息

以下页中包括机械、封装和可订购信息。这些信息是针对指定器件可提供的最新数据。这些数据会在无通知且不对本文档进行修订的情况下发生改变。欲获得该数据表的浏览器版本，请查阅左侧的导航栏。

**PACKAGING INFORMATION**

| Orderable part number           | Status<br>(1) | Material type<br>(2) | Package   Pins  | Package qty   Carrier | RoHS<br>(3) | Lead finish/<br>Ball material<br>(4) | MSL rating/<br>Peak reflow<br>(5) | Op temp (°C) | Part marking<br>(6) |
|---------------------------------|---------------|----------------------|-----------------|-----------------------|-------------|--------------------------------------|-----------------------------------|--------------|---------------------|
| <a href="#">SN75DP126SSRHUR</a> | Active        | Production           | WQFN (RHU)   56 | 2000   LARGE T&R      | Yes         | NIPDAU                               | Level-2-260C-1 YEAR               | 0 to 85      | DP126SS             |
| SN75DP126SSRHUR.B               | Active        | Production           | WQFN (RHU)   56 | 2000   LARGE T&R      | Yes         | NIPDAU                               | Level-2-260C-1 YEAR               | 0 to 85      | DP126SS             |

(1) **Status:** For more details on status, see our [product life cycle](#).

(2) **Material type:** When designated, preproduction parts are prototypes/experimental devices, and are not yet approved or released for full production. Testing and final process, including without limitation quality assurance, reliability performance testing, and/or process qualification, may not yet be complete, and this item is subject to further changes or possible discontinuation. If available for ordering, purchases will be subject to an additional waiver at checkout, and are intended for early internal evaluation purposes only. These items are sold without warranties of any kind.

(3) **RoHS values:** Yes, No, RoHS Exempt. See the [TI RoHS Statement](#) for additional information and value definition.

(4) **Lead finish/Ball material:** Parts may have multiple material finish options. Finish options are separated by a vertical ruled line. Lead finish/Ball material values may wrap to two lines if the finish value exceeds the maximum column width.

(5) **MSL rating/Peak reflow:** The moisture sensitivity level ratings and peak solder (reflow) temperatures. In the event that a part has multiple moisture sensitivity ratings, only the lowest level per JEDEC standards is shown. Refer to the shipping label for the actual reflow temperature that will be used to mount the part to the printed circuit board.

(6) **Part marking:** There may be an additional marking, which relates to the logo, the lot trace code information, or the environmental category of the part.

Multiple part markings will be inside parentheses. Only one part marking contained in parentheses and separated by a "-" will appear on a part. If a line is indented then it is a continuation of the previous line and the two combined represent the entire part marking for that device.

**Important Information and Disclaimer:**The information provided on this page represents TI's knowledge and belief as of the date that it is provided. TI bases its knowledge and belief on information provided by third parties, and makes no representation or warranty as to the accuracy of such information. Efforts are underway to better integrate information from third parties. TI has taken and continues to take reasonable steps to provide representative and accurate information but may not have conducted destructive testing or chemical analysis on incoming materials and chemicals. TI and TI suppliers consider certain information to be proprietary, and thus CAS numbers and other limited information may not be available for release.

In no event shall TI's liability arising out of such information exceed the total purchase price of the TI part(s) at issue in this document sold by TI to Customer on an annual basis.

## TAPE AND REEL INFORMATION



### QUADRANT ASSIGNMENTS FOR PIN 1 ORIENTATION IN TAPE



\*All dimensions are nominal

| Device          | Package Type | Package Drawing | Pins | SPQ  | Reel Diameter (mm) | Reel Width W1 (mm) | A0 (mm) | B0 (mm) | K0 (mm) | P1 (mm) | W (mm) | Pin1 Quadrant |
|-----------------|--------------|-----------------|------|------|--------------------|--------------------|---------|---------|---------|---------|--------|---------------|
| SN75DP126SSRHUR | WQFN         | RHU             | 56   | 2000 | 330.0              | 24.4               | 5.3     | 11.3    | 1.0     | 8.0     | 24.0   | Q1            |

TAPE AND REEL BOX DIMENSIONS



\*All dimensions are nominal

| Device          | Package Type | Package Drawing | Pins | SPQ  | Length (mm) | Width (mm) | Height (mm) |
|-----------------|--------------|-----------------|------|------|-------------|------------|-------------|
| SN75DP126SSRHUR | WQFN         | RHU             | 56   | 2000 | 367.0       | 367.0      | 45.0        |



# EXAMPLE BOARD LAYOUT

RHU0056A

WQFN - 0.8 mm max height

PLASTIC QUAD FLATPACK - NO LEAD

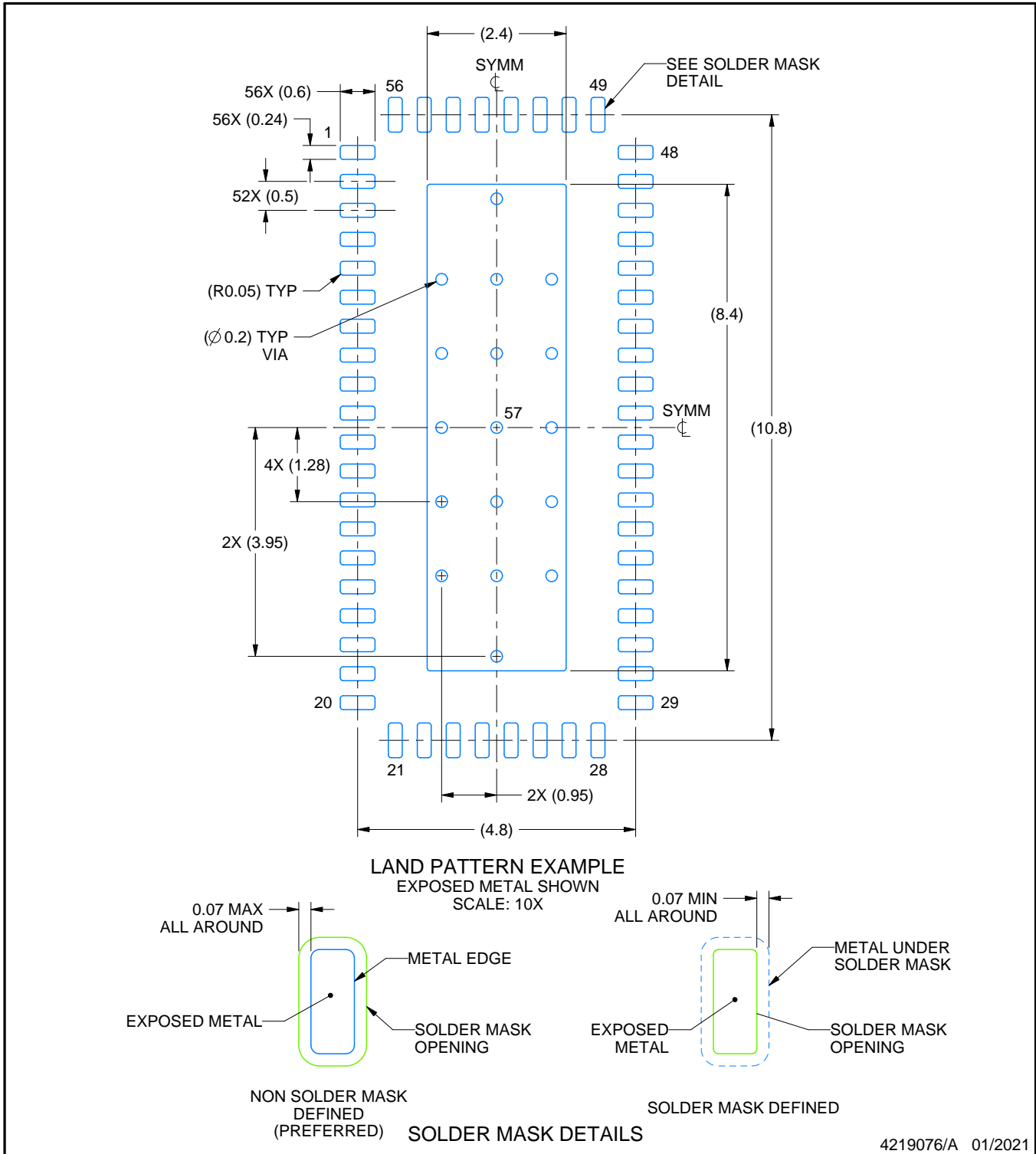

4219076/A 01/2021

NOTES: (continued)

4. This package is designed to be soldered to a thermal pad on the board. For more information, see Texas Instruments literature number SLUA271 ([www.ti.com/lit/sluea271](http://www.ti.com/lit/sluea271)).
5. Vias are optional depending on application, refer to device data sheet. If any vias are implemented, refer to their locations shown on this view. It is recommended that vias under paste be filled, plugged or tented.

# EXAMPLE STENCIL DESIGN

RHU0056A

WQFN - 0.8 mm max height

PLASTIC QUAD FLATPACK - NO LEAD

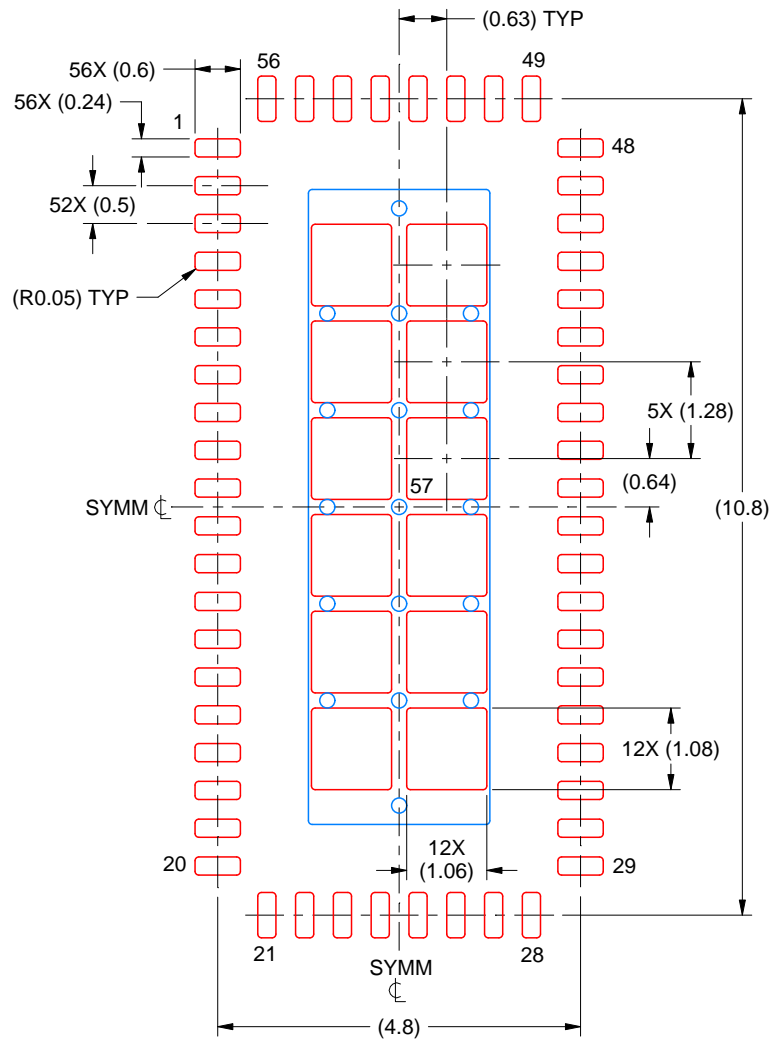

SOLDER PASTE EXAMPLE  
BASED ON 0.125 MM THICK STENCIL  
SCALE: 10X

EXPOSED PAD 57  
68% PRINTED SOLDER COVERAGE BY AREA UNDER PACKAGE

4219076/A 01/2021

NOTES: (continued)

6. Laser cutting apertures with trapezoidal walls and rounded corners may offer better paste release. IPC-7525 may have alternate design recommendations.

## 重要通知和免责声明

TI“按原样”提供技术和可靠性数据（包括数据表）、设计资源（包括参考设计）、应用或其他设计建议、网络工具、安全信息和其他资源，不保证没有瑕疵且不做任何明示或暗示的担保，包括但不限于对适销性、与某特定用途的适用性或不侵犯任何第三方知识产权的暗示担保。

这些资源可供使用 TI 产品进行设计的熟练开发人员使用。您将自行承担以下全部责任：(1) 针对您的应用选择合适的 TI 产品，(2) 设计、验证并测试您的应用，(3) 确保您的应用满足相应标准以及任何其他安全、安保法规或其他要求。

这些资源如有变更，恕不另行通知。TI 授权您仅可将这些资源用于研发本资源所述的 TI 产品的相关应用。严禁以其他方式对这些资源进行复制或展示。您无权使用任何其他 TI 知识产权或任何第三方知识产权。对于因您对这些资源的使用而对 TI 及其代表造成的任何索赔、损害、成本、损失和债务，您将全额赔偿，TI 对此概不负责。

TI 提供的产品受 [TI 销售条款](#)、[TI 通用质量指南](#) 或 [ti.com](#) 上其他适用条款或 TI 产品随附的其他适用条款的约束。TI 提供这些资源并不会扩展或以其他方式更改 TI 针对 TI 产品发布的适用的担保或担保免责声明。除非德州仪器 (TI) 明确将某产品指定为定制产品或客户特定产品，否则其产品均为按确定价格收入目录的标准通用器件。

TI 反对并拒绝您可能提出的任何其他或不同的条款。

版权所有 © 2025，德州仪器 (TI) 公司

最后更新日期：2025 年 10 月