

## SN74HC165B-EP 5V、并行负载 8 位移位寄存器（增强型产品）

### 1 特性

- 2 V 至 6 V  $V_{CC}$  运行
- 闩锁性能超过 250mA，符合 JESD 17 规范
- 工作环境温度：-55°C 至 +125°C
- 支持国防、航空航天和医疗应用：
  - 受控基线
  - 一个封装测试厂
  - 一个制造基地
  - 延长了产品生命周期
  - 产品可追溯性

### 2 应用

- 增加微控制器上的输入数量

### 3 说明

SN74HC165B-EP 器件是一款 8 位并行负载移位寄存器，旨在 2V 至 6V  $V_{CC}$  下运行。

器件计时时，数据通过串行输出  $Q_H$  传输。当移位/负载 (SH/LD) 输入为低电平时，可支持八个单独的直接数据输入，从而实现在每个级的并行输入。SN74HC165B-EP 器件具有时钟抑制功能和补充串行输出  $\bar{Q}_H$ 。

#### 封装信息

器件型号	封装 <sup>(1)</sup>	封装尺寸 <sup>(2)</sup>
SN74HC165B-EP	PW ( TSSOP, 16 )	5mm × 6.4mm

(1) 如需了解所有可用封装，请参阅数据表末尾的可订购产品附录。

(2) 封装尺寸 (长 × 宽) 为标称值，并包括引脚 (如适用)。

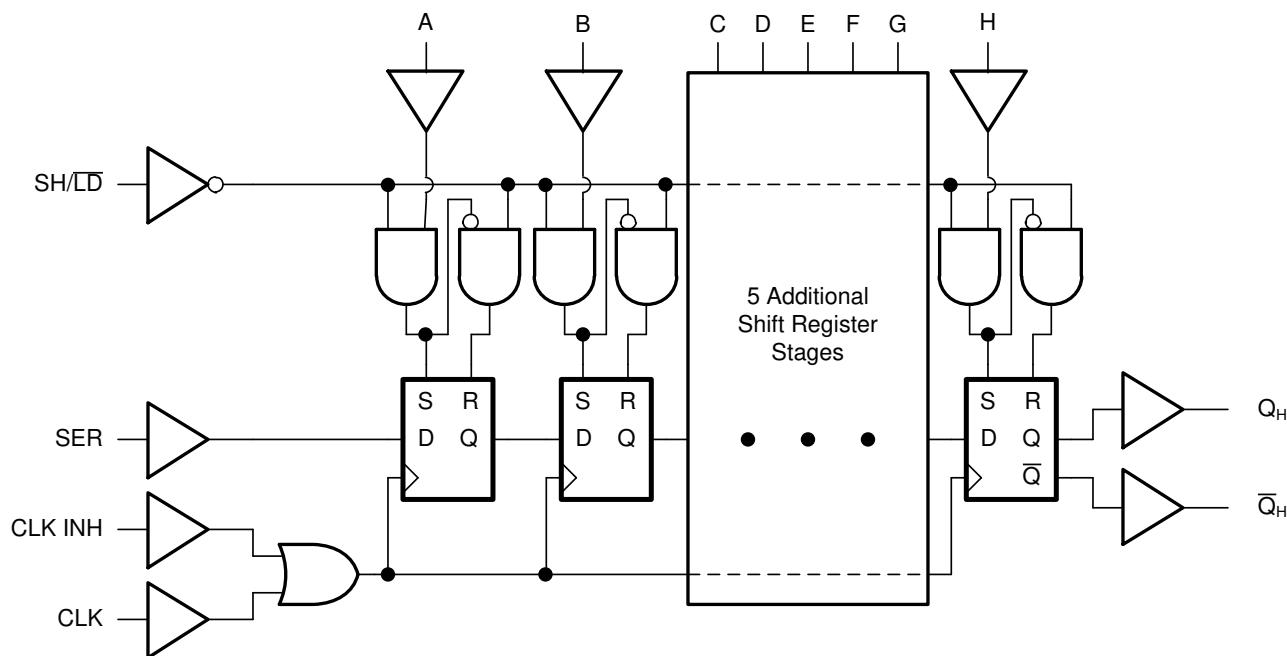

逻辑图 (正逻辑)



## Table of Contents

<b>1 特性</b> .....	1	<b>8 Detailed Description</b> .....	10
<b>2 应用</b> .....	1	8.1 Overview.....	10
<b>3 说明</b> .....	1	8.2 Functional Block Diagram.....	10
<b>4 Revision History</b> .....	2	8.3 Feature Description.....	10
<b>5 Pin Configuration and Functions</b> .....	3	8.4 Device Functional Modes.....	11
<b>6 Specifications</b> .....	4	<b>9 Application and Implementation</b> .....	12
6.1 Absolute Maximum Ratings.....	4	9.1 Application Information.....	12
6.2 ESD Ratings.....	4	9.2 Typical Application.....	12
6.3 Recommended Operating Conditions.....	5	9.3 Power Supply Recommendations.....	14
6.4 Thermal Information.....	5	9.4 Layout.....	15
6.5 Electrical Characteristics.....	6	<b>10 Device and Documentation Support</b> .....	16
6.6 Timing Requirements, $V_{CC} = 2\text{ V}$ .....	6	10.1 Related Documentation.....	16
6.7 Timing Requirements, $V_{CC} = 4.5\text{ V}$ .....	6	10.2 Receiving Notification of Documentation Updates..	16
6.8 Timing Requirements, $V_{CC} = 6\text{ V}$ .....	7	10.3 支持资源.....	16
6.9 Switching Characteristics, $V_{CC} = 2\text{ V}$ .....	8	10.4 Trademarks.....	16
6.10 Switching Characteristics, $V_{CC} = 4.5\text{ V}$ .....	8	10.5 静电放电警告.....	16
6.11 Switching Characteristics, $V_{CC} = 6\text{ V}$ .....	8	10.6 术语表.....	16
6.12 Operating Characteristics.....	8	<b>11 Mechanical, Packaging, and Orderable Information</b> .....	16
6.13 Typical Characteristics.....	8		
<b>7 Parameter Measurement Information</b> .....	9		

## 4 Revision History

DATE	REVISION	NOTES
August 2023	*	Initial Release

## 5 Pin Configuration and Functions



图 5-1. SN74HC165B-EP: PW Package, 16-Pin TSSOP (Top View)

表 5-1. Pin Functions

PIN		TYPE <sup>(1)</sup>	DESCRIPTION
NAME	NO.		
A	11	I	Serial input A
B	12	I	Serial input B
C	13	I	Serial input C
CLK	2	I	Storage clock
CLK INH	15	I	Storage clock
D	14	I	Serial input D
E	3	I	Serial input E
F	4	I	Serial input F
G	5	I	Serial input G
GND	8	—	Ground pin
H	6	I	Serial input H
$\bar{Q}_H$	7	O	Output H, inverted
$Q_H$	9	O	Output H
SH/ LD	1	I	Load Input
SER	10	I	Serial input
V <sub>CC</sub>	16	—	Power pin

(1) I = Input, O = Output, I/O = Input or Output, G = Ground, P = Power.

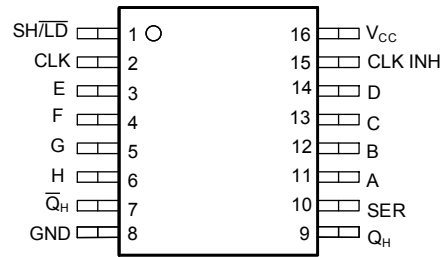
## 6 Specifications

### 6.1 Absolute Maximum Ratings

Over operating free-air temperature range (unless otherwise noted)<sup>(1)</sup>

		MIN	MAX	UNIT
V <sub>CC</sub>	Supply voltage	- 0.5	7	V
V <sub>I</sub>	Input voltage <sup>(2)</sup>	- 0.5	7	V
V <sub>O</sub>	Voltage range applied to any output in the high-impedance or power-off state <sup>(2)</sup>	- 0.5	7	V
V <sub>O</sub>	Output voltage <sup>(2) (3)</sup>	- 0.5	V <sub>CC</sub> + 0.5	V
I <sub>IK</sub>	Input clamp current	V <sub>I</sub> < 0	±20	mA
I <sub>OK</sub>	Output clamp current	V <sub>O</sub> < 0	±20	mA
I <sub>O</sub>	Continuous output current	V <sub>O</sub> = 0 to V <sub>CC</sub>	±25	mA
	Continuous current through V <sub>CC</sub> or GND		±50	mA
T <sub>stg</sub>	Storage temperature	- 65	150	°C

- (1) Operation outside the *Absolute Maximum Ratings* may cause permanent device damage. *Absolute Maximum Ratings* do not imply functional operation of the device at these or any other conditions beyond those listed under *Recommended Operating Conditions*. If used outside the *Recommended Operating Conditions* but within the *Absolute Maximum Ratings*, the device may not be fully functional, and this may affect device reliability, functionality, performance, and shorten the device lifetime.
- (2) The input and output negative-voltage ratings may be exceeded if the input and output current ratings are observed.
- (3) This value is limited to 5.5 V maximum.

### 6.2 ESD Ratings

		VALUE	UNIT
V <sub>(ESD)</sub>	Electrostatic discharge	Human-body model (HBM), per ANSI/ESDA/JEDEC JS-001 <sup>(1)</sup>	±2000
		Charged-device model (CDM), per ANSI/ESDA/JEDEC JS-002 <sup>(2)</sup>	±1000

- (1) JEDEC document JEP155 states that 500-V HBM allows safe manufacturing with a standard ESD control process.
- (2) JEDEC document JEP157 states that 250-V CDM allows safe manufacturing with a standard ESD control process

### 6.3 Recommended Operating Conditions

over operating free-air temperature range (unless otherwise noted)<sup>(1)</sup>

		MIN	MAX	UNIT
V <sub>CC</sub>	Supply voltage	2	6	V
V <sub>IH</sub>	High-level input voltage	V <sub>CC</sub> = 2 V	1.5	V
		V <sub>CC</sub> = 4.5 V	3.15	
		V <sub>CC</sub> = 6 V	4.2	
V <sub>IL</sub>	Low-level input voltage	V <sub>CC</sub> = 2 V	0.5	V
		V <sub>CC</sub> = 4.5 V	1.35	
		V <sub>CC</sub> = 6 V	1.8	
V <sub>I</sub>	Input voltage	0	V <sub>CC</sub>	V
V <sub>O</sub>	Output voltage	0	V <sub>CC</sub>	V
Δt/Δv	Input transition rise or fall rate	V <sub>CC</sub> = 2 V	1000	ns/V
		V <sub>CC</sub> = 4.5 V	500	
		V <sub>CC</sub> = 6 V	400	
T <sub>A</sub>	Operating free-air temperature	- 55	125	°C

(1) All unused inputs of the device must be held at V<sub>CC</sub> or GND for proper device operation. See [Implications of Slow or Floating CMOS Inputs](#).

### 6.4 Thermal Information

THERMAL METRIC <sup>(1)</sup>		SN74HC165B-EP	UNIT
		PW (TSSOP)	
		16 PINS	
R <sub>θJA</sub>	Junction-to-ambient thermal resistance	131.2	°C/W
R <sub>θJC(top)</sub>	Junction-to-case (top) thermal resistance	69.4	°C/W
R <sub>θJB</sub>	Junction-to-board thermal resistance	75.8	°C/W
ψ <sub>JT</sub>	Junction-to-top characterization parameter	21.0	°C/W
ψ <sub>JB</sub>	Junction-to-board characterization parameter	75.4	°C/W
R <sub>θJC(bot)</sub>	Junction-to-case (bottom) thermal resistance	—	°C/W

(1) For more information about traditional and new thermal metrics, see [Semiconductor and IC Package Thermal Metrics](#).

## 6.5 Electrical Characteristics

over operating free-air temperature range (unless otherwise noted).

PARAMETER		V <sub>CC</sub>	MIN	TYP	MAX	UNIT
V <sub>OH</sub>	I <sub>OH</sub> = -20 μA	2 V to 6 V	V <sub>CC</sub> - 0.1			V
	I <sub>OH</sub> = -4 mA	4.5 V	3.7	4.3		
	I <sub>OH</sub> = -5.2 mA	6 V	5.2	5.8		
V <sub>OL</sub>	I <sub>OL</sub> = 20 μA	2 V to 6 V			0.1	V
	I <sub>OL</sub> = 4 mA	4.5 V		0.17	0.4	
	I <sub>OL</sub> = 5.2 mA	6 V		0.15	0.4	
I <sub>I</sub>	V <sub>I</sub> = V <sub>CC</sub> or GND	6 V		±0.1	±1	μA
I <sub>CC</sub>	V <sub>I</sub> = V <sub>CC</sub> or GND, I <sub>O</sub> = 0	6 V			160	μA
C <sub>i</sub>	V <sub>I</sub> = V <sub>CC</sub> or GND	2 V to 6 V		3	10	pF

## 6.6 Timing Requirements, V<sub>CC</sub> = 2 V

over recommended operating free-air temperature range (unless otherwise noted) (see 节 7)

PARAMETER	TEST CONDITION	25°C		-55°C to 125°C		UNIT
		MIN	MAX	MIN	MAX	
f <sub>clock</sub>	Clock frequency	6		4.2		MHz
t <sub>w</sub>	Pulse duration	CLK high or low	80	120		ns
		SH/ $\overline{\text{LD}}$ low	80	120		
t <sub>su</sub>	Setup time	SH/ $\overline{\text{LD}}$ high before CLK ↑	80	120		ns
		SER before CLK ↑	40	60		
		CLK INH before CLK ↑	100	150		
		Data before SH/ $\overline{\text{LD}}$ ↑	100	150		
t <sub>h</sub>	Hold time	SER data after CLK ↑	5	5		ns
		Parallel data after SH/ $\overline{\text{LD}}$ ↑	5	5		
		SH/ $\overline{\text{LD}}$ high after CLK ↑	5	5		

## 6.7 Timing Requirements, V<sub>CC</sub> = 4.5 V

over recommended operating free-air temperature range (unless otherwise noted) (see 节 7)

PARAMETER	TEST CONDITION	25°C		-55°C to 125°C		UNIT
		MIN	MAX	MIN	MAX	
f <sub>clock</sub>	Clock frequency	31		21		MHz
t <sub>w</sub>	Pulse duration	CLK high or low	16	24		ns
		SH/ $\overline{\text{LD}}$ low	16	24		
t <sub>su</sub>	Setup time	SH/ $\overline{\text{LD}}$ high before CLK ↑	16	24		ns
		SER before CLK ↑	8	12		
		CLK INH before CLK ↑	20	30		
		Data before SH/ $\overline{\text{LD}}$ ↑	20	30		
t <sub>h</sub>	Hold time	SER data after CLK ↑	5	5		ns
		Parallel data after SH/ $\overline{\text{LD}}$ ↑	5	5		
		SH/ $\overline{\text{LD}}$ high after CLK ↑	5	5		

### 6.8 Timing Requirements, $V_{CC} = 6 V$

over recommended operating free-air temperature range (unless otherwise noted) (see 节 7)

PARAMETER	TEST CONDITION	25°C		- 55°C to 125°C		UNIT
		MIN	MAX	MIN	MAX	
$f_{clock}$	Clock frequency	36		25		MHz
$t_w$	Pulse duration	CLK high or low	14	20	ns	
		SH/ $\overline{LD}$ low	14	20		
$t_{su}$	Setup time	SH/ $\overline{LD}$ high before CLK $\uparrow$	14	20	ns	
		SER before CLK $\uparrow$	7	10		
		CLK INH before CLK $\uparrow$	17	25		
		Data before SH/ $\overline{LD}$ $\uparrow$	17	26		
$t_h$	Hold time	SER data after CLK $\uparrow$	5	5	ns	
		Parallel data after SH/ $\overline{LD}$ $\uparrow$	5	5		
		SH/ $\overline{LD}$ high after CLK $\uparrow$	5	5		



图 6-1. Typical Shift, Load, and Inhibit Sequences

### 6.9 Switching Characteristics, $V_{CC} = 2\text{ V}$

over operating free-air temperature range (unless otherwise noted), (see 节 7)

PARAMETER	FROM (INPUT)	TO (OUTPUT)	LOAD CAP	25°C			- 55°C to 125°C			UNIT
				MIN	TYP	MAX	MIN	TYP	MAX	
$t_{pd}$	CLK	$Q_H$ or $\bar{Q}$	$C_L = 50\text{ pF}$		75	150			225	ns
	SH/ $\bar{LD}$			80	150			225		
	H			75	150			225		

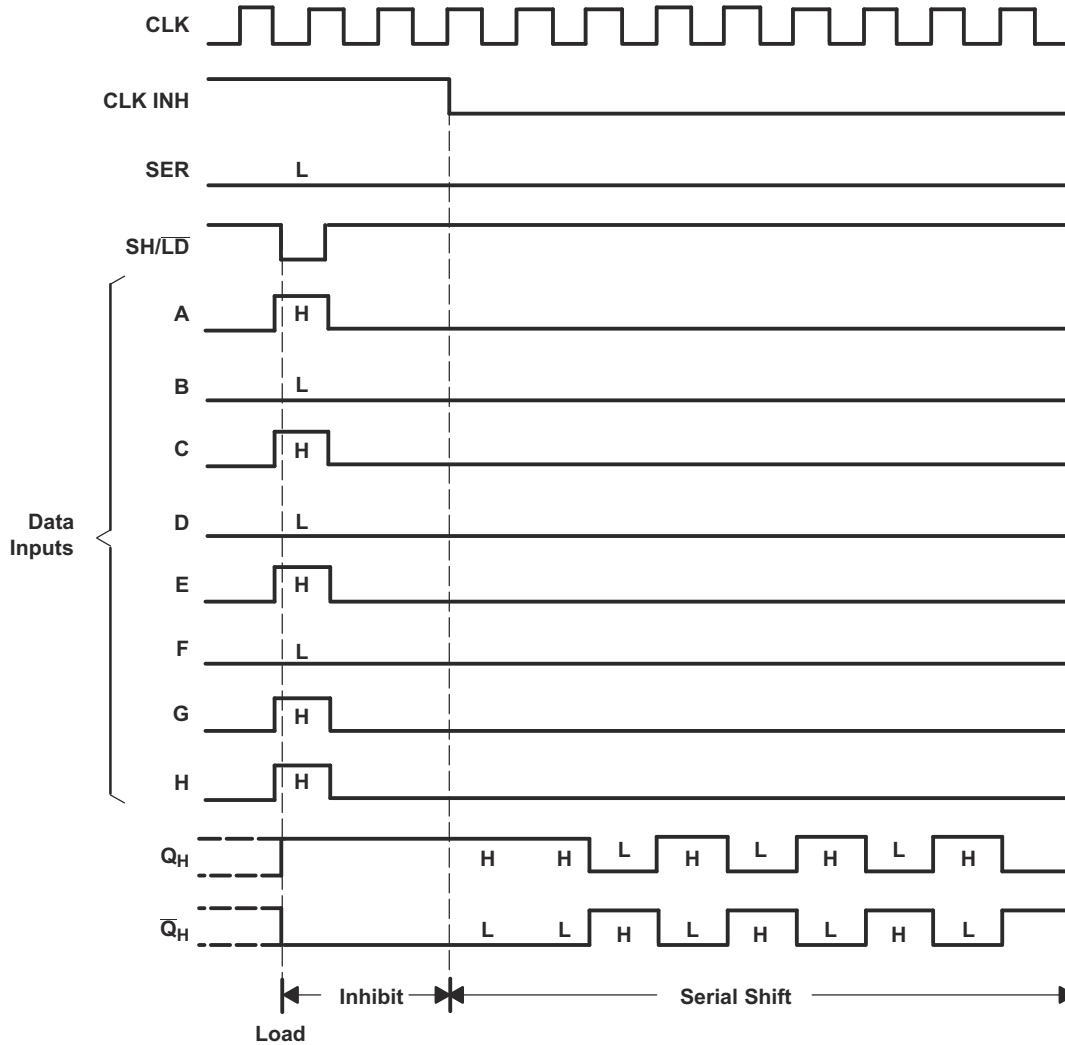
### 6.10 Switching Characteristics, $V_{CC} = 4.5\text{ V}$

over operating free-air temperature range (unless otherwise noted), (see 节 7)

PARAMETER	FROM (INPUT)	TO (OUTPUT)	LOAD CAP	25°C			- 55°C to 125°C			UNIT
				MIN	TYP	MAX	MIN	TYP	MAX	
$t_{pd}$	CLK	$Q_H$ or $\bar{Q}$	$C_L = 50\text{ pF}$		15	30			45	ns
	SH/ $\bar{LD}$			20	30			45		
	H			15	30			45		

### 6.11 Switching Characteristics, $V_{CC} = 6\text{ V}$

over recommended operating free-air temperature range (unless otherwise noted), (see 节 7)

PARAMETER	FROM (INPUT)	TO (OUTPUT)	LOAD CAP	25°C			- 55°C to 125°C			UNIT
				MIN	TYP	MAX	MIN	TYP	MAX	
$t_{pd}$	CLK	$Q_H$ or $\bar{Q}$	$C_L = 50\text{ pF}$		13	26			38	ns
	SH/ $\bar{LD}$			16	26			38		
	H			13	26			38		

### 6.12 Operating Characteristics

$T_A = 25^\circ\text{C}$

PARAMETER		TEST CONDITIONS	$V_{CC}$	TYP	UNIT
$C_{pd}$	Power dissipation capacitance	No load	6 V	75	pF

### 6.13 Typical Characteristics

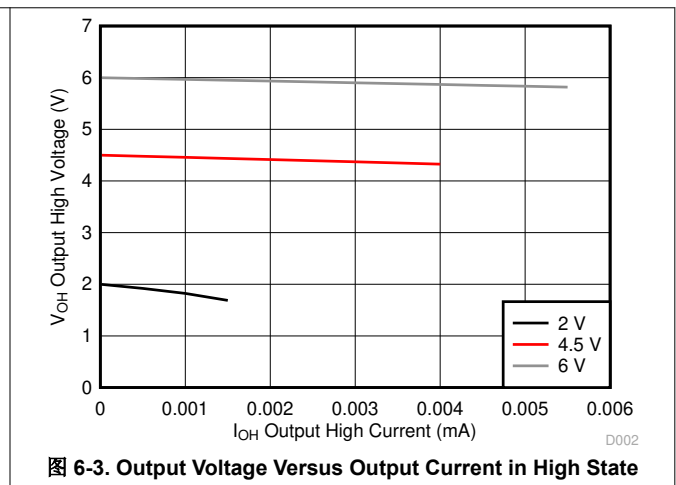
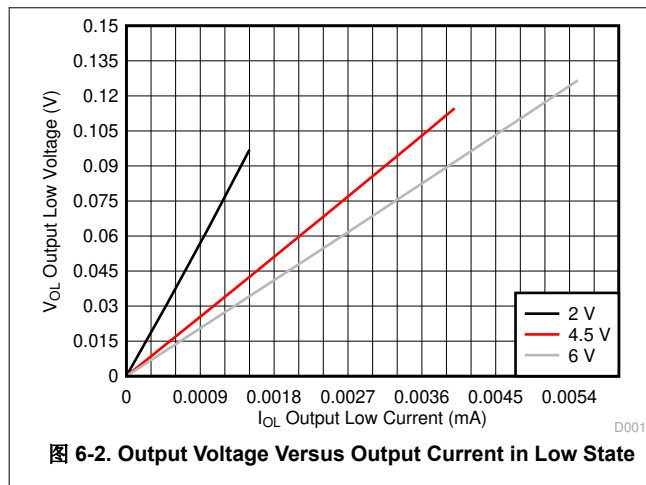

## 7 Parameter Measurement Information

- Phase relationships between waveforms were chosen arbitrarily. All input pulses are supplied by generators having the following characteristics:  $PRR \leq 1 \text{ MHz}$ ,  $Z_O = 50 \Omega$ ,  $t_t < 6 \text{ ns}$ .
- The outputs are measured one at a time, with one input transition per measurement.

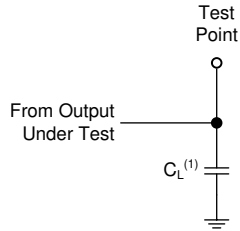

A.  $C_L = 50 \text{ pF}$  and includes probe and jig capacitance.

图 7-1. Load Circuit



图 7-3. Voltage Waveforms Setup and Hold Times



A. The maximum between  $t_r$  and  $t_f$  is used for  $t_t$ .

图 7-2. Voltage Waveforms Transition Times

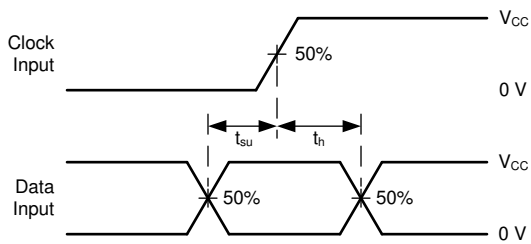
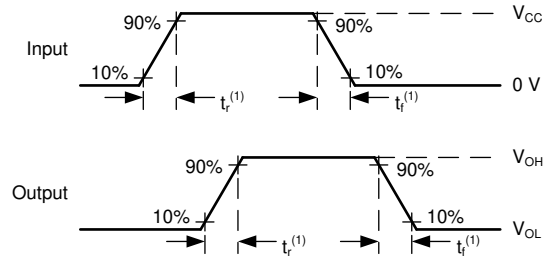

图 7-4. Voltage Waveforms Pulse Width



A. The maximum between  $t_{PLH}$  and  $t_{PHL}$  is used for  $t_{pd}$ .

图 7-5. Voltage Waveforms Propagation Delays

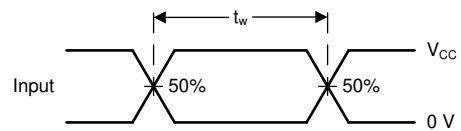
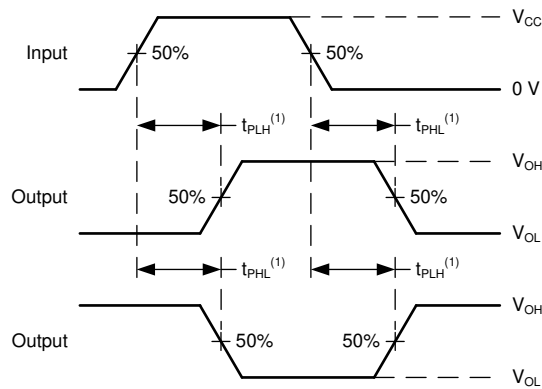
## 8 Detailed Description

### 8.1 Overview

The SN74HC165B-EP device is a parallel-load, 8-bit shift registers designed for 2 V to 6 V  $V_{CC}$  operation.

When the device is clocked, data is shifted toward the serial output  $Q_H$ . Parallel-in access to each stage is provided by eight individual direct data inputs that are enabled by a low level at the shift/load ( $SH/\overline{LD}$ ) input. The SN74HC165B-EP features a clock-inhibit function and a complemented serial output,  $\overline{Q}_H$ .

Clocking is accomplished by a low-to-high transition of the clock (CLK) input while  $SH/\overline{LD}$  is held high and clock inhibit (CLK INH) is held low. The functions of CLK and CLK INH are interchangeable. Since a low CLK and a low-to-high transition of CLK INH accomplishes clocking, CLK INH must be changed to the high level only while CLK is high. Parallel loading is inhibited when  $SH/\overline{LD}$  is held high. The parallel inputs to the register are enabled while  $SH/\overline{LD}$  is held low, independently of the levels of CLK, CLK INH, or SER.

### 8.2 Functional Block Diagram

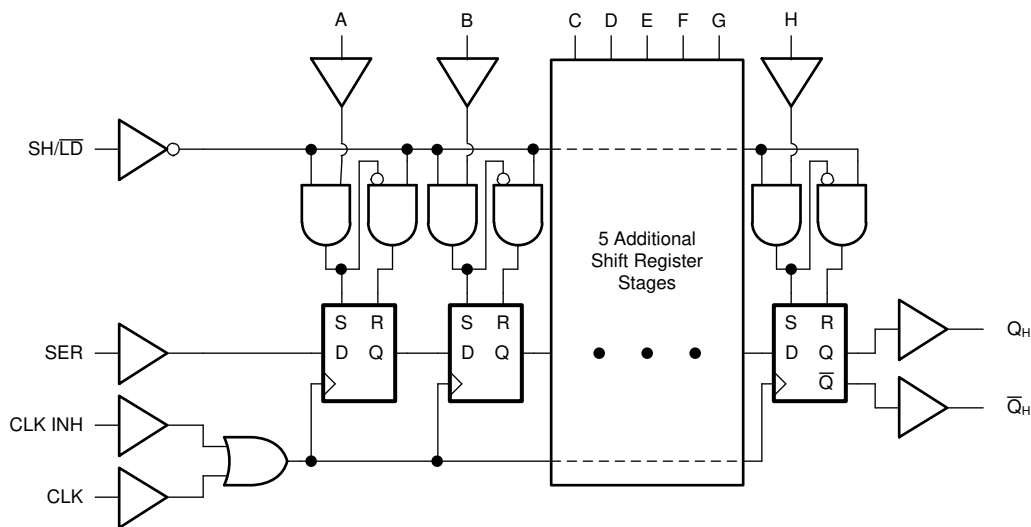

### 8.3 Feature Description

#### 8.3.1 Balanced CMOS Push-Pull Outputs

This device includes balanced CMOS push-pull outputs. The term *balanced* indicates that the device can sink and source similar currents. The drive capability of this device may create fast edges into light loads, so routing and load conditions should be considered to prevent ringing. Additionally, the outputs of this device are capable of driving larger currents than the device can sustain without being damaged. It is important for the output power of the device to be limited to avoid damage due to overcurrent. The electrical and thermal limits defined in the *Absolute Maximum Ratings* must be followed at all times.

Unused push-pull CMOS outputs should be left disconnected.

#### 8.3.2 Latching Logic

This device includes latching logic circuitry. Latching circuits commonly include D-type latches and D-type flip-flops, but include all logic circuits that act as volatile memory.

When the device is powered on, the state of each latch is unknown. There is no default state for each latch at start-up.

The output state of each latching logic circuit only remains stable as long as power is applied to the device within the supply voltage range specified in the *Recommended Operating Conditions* table.

### 8.3.3 Clamp Diode Structure

图 8-1 shows the inputs and outputs to this device have negative clamping diodes only.

小心

Voltages beyond the values specified in the *Absolute Maximum Ratings* table can cause damage to the device. The input and output voltage ratings may be exceeded if the input and output clamp-current ratings are observed.



图 8-1. Electrical Placement of Clamping Diodes for Each Input and Output

### 8.4 Device Functional Modes

表 8-1 和 表 8-2 list the functional modes of the SN74HC165B-EP.

表 8-1. Operating Mode Table

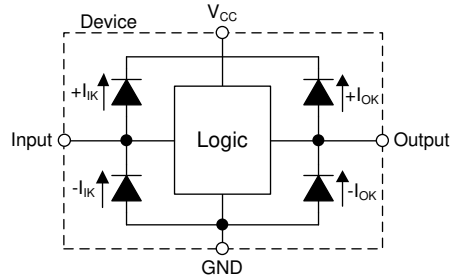
INPUTS <sup>(1)</sup>			FUNCTION
SH/LD	CLK	CLK INH	
L	X	X	Parallel load
H	H	X	No change
H	X	H	No change
H	L	↑	Shift <sup>(2)</sup>
H	↑	L	Shift <sup>(2)</sup>

- (1) H = High Voltage Level, L = Low Voltage Level, X = Do Not Care, ↑ = Low to High transition
- (2) Shift: content of each internal register shifts towards serial output  $Q_H$ . Data at SER is shifted into the first register.

表 8-2. Output Function Table

INTERNAL REGISTERS <sup>(1) (2)</sup>		OUTPUTS <sup>(2)</sup>	
A — G	H	Q	$\bar{Q}$
X	L	L	H
X	H	H	L

- (1) Internal registers refer to the shift registers inside the device. These values are set by either loading data from the parallel inputs, or by clocking data in from the serial input.
- (2) H = High Voltage Level, L = Low Voltage Level, X = Do Not Care

## 9 Application and Implementation

### 备注

Information in the following applications sections is not part of the TI component specification, and TI does not warrant its accuracy or completeness. TI's customers are responsible for determining suitability of components for their purposes, as well as validating and testing their design implementation to confirm system functionality.

### 9.1 Application Information

The SN74HC165B-EP is a low drive CMOS device that can be used for a multitude of bus interface type applications where output ringing is a concern. The low-drive and slow-edge rates minimize overshoot and undershoot on the outputs.

### 9.2 Typical Application



图 9-1. Input Expansion with Shift Registers

### 9.2.1 Power Considerations

Ensure the desired supply voltage is within the range specified in the *Recommended Operating Conditions*. The supply voltage sets the device's electrical characteristics as described in the *Electrical Characteristics* section.

The positive voltage supply must be capable of sourcing current equal to the total current to be sourced by all outputs of the SN74HC165B-EP plus the maximum static supply current,  $I_{CC}$ , listed in the *Electrical Characteristics*, and any transient current required for switching. The logic device can only source as much current that is provided by the positive supply source. Be sure to not exceed the maximum total current through  $V_{CC}$  listed in the *Absolute Maximum Ratings*.

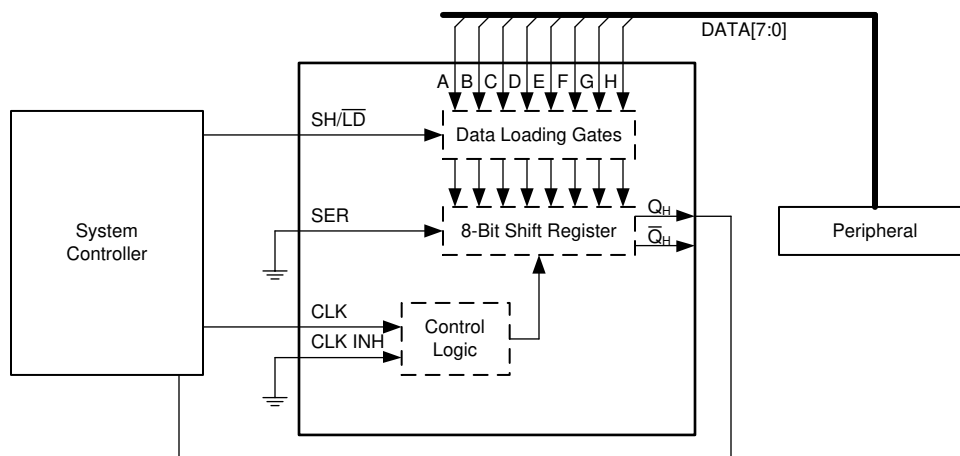
The ground must be capable of sinking current equal to the total current to be sunk by all outputs of the SN74HC165B-EP plus the maximum supply current,  $I_{CC}$ , listed in the *Electrical Characteristics*, and any transient current required for switching. The logic device can only sink as much current that can be sunk into its ground connection. Be sure to not exceed the maximum total current through GND listed in the *Absolute Maximum Ratings*.

The SN74HC165B-EP can drive a load with a total capacitance less than or equal to 50 pF while still meeting all of the data sheet specifications. Larger capacitive loads can be applied; however, it is not recommended to exceed 50 pF.

The SN74HC165B-EP can drive a load with total resistance described by  $R_L \geq V_O / I_O$ , with the output voltage and current defined in the *Electrical Characteristics* table with  $V_{OH}$  and  $V_{OL}$ . When outputting in the HIGH state, the output voltage in the equation is defined as the difference between the measured output voltage and the supply voltage at the  $V_{CC}$  pin.

Total power consumption can be calculated using the information provided in [CMOS Power Consumption and Cpd Calculation](#).

Thermal increase can be calculated using the information provided in [Thermal Characteristics of Standard Linear and Logic \(SLL\) Packages and Devices](#).

#### 小心

The maximum junction temperature,  $T_{J(max)}$  listed in the *Absolute Maximum Ratings*, is an additional limitation to prevent damage to the device. Do not violate any values listed in the *Absolute Maximum Ratings*. These limits are provided to prevent damage to the device.

### 9.2.2 Input Considerations

Input signals must cross  $V_{IL(max)}$  to be considered a logic LOW, and  $V_{IH(min)}$  to be considered a logic HIGH. Do not exceed the maximum input voltage range found in the *Absolute Maximum Ratings*.

Unused inputs must be terminated to either  $V_{CC}$  or ground. The unused inputs can be directly terminated if the input is completely unused, or they can be connected with a pull-up or pull-down resistor if the input will be used sometimes, but not always. A pull-up resistor is used for a default state of HIGH, and a pull-down resistor is used for a default state of LOW. The drive current of the controller, leakage current into the SN74HC165B-EP (as specified in the *Electrical Characteristics*), and the desired input transition rate limits the resistor size. A 10-k $\Omega$  resistor value is often used due to these factors.

The SN74HC165B-EP has CMOS inputs and thus requires fast input transitions to operate correctly, as defined in the *Recommended Operating Conditions* table. Slow input transitions can cause oscillations, additional power consumption, and reduction in device reliability.

Refer to the *Feature Description* section for additional information regarding the inputs for this device.

### 9.2.3 Output Considerations

The positive supply voltage is used to produce the output HIGH voltage. Drawing current from the output will decrease the output voltage as specified by the  $V_{OH}$  specification in the *Electrical Characteristics*. The ground voltage is used to produce the output LOW voltage. Sinking current into the output will increase the output voltage as specified by the  $V_{OL}$  specification in the *Electrical Characteristics*.

Push-pull outputs that could be in opposite states, even for a very short time period, should never be connected directly together. This can cause excessive current and damage to the device.

Two channels within the same device with the same input signals can be connected in parallel for additional output drive strength.

Unused outputs can be left floating. Do not connect outputs directly to  $V_{CC}$  or ground.

Refer to the *Feature Description* section for additional information regarding the outputs for this device.

### 9.2.4 Detailed Design Procedure

1. Add a decoupling capacitor from  $V_{CC}$  to GND. The capacitor needs to be placed physically close to the device and electrically close to both the  $V_{CC}$  and GND pins. An example layout is shown in the *Layout* section.
2. Ensure the capacitive load at the output is  $\leq 50$  pF. This is not a hard limit; by design, however, it will optimize performance. This can be accomplished by providing short, appropriately sized traces from the SN74HC165B-EP to one or more of the receiving devices.
3. Ensure the resistive load at the output is larger than  $(V_{CC} / I_{O(max)}) \Omega$ , which will not violate the maximum output current from the *Absolute Maximum Ratings*. Most CMOS inputs have a resistive load measured in  $M\Omega$ ; much larger than the minimum calculated previously.
4. Thermal issues are rarely a concern for logic gates; the power consumption and thermal increase, however, can be calculated using the steps provided in the application report, [CMOS Power Consumption and Cpd Calculation](#).

### 9.2.5 Application Curves



图 9-2. Application Timing Diagram

## 9.3 Power Supply Recommendations

The power supply can be any voltage between the minimum and maximum supply voltage rating located in the *Absolute Maximum Ratings* section. Each  $V_{CC}$  terminal must have a good bypass capacitor to prevent power disturbance. For devices with a single supply, TI recommends a 0.1- $\mu$ F capacitor; if there are multiple  $V_{CC}$  terminals, then TI recommends a 0.01- $\mu$ F or 0.022- $\mu$ F capacitor for each power terminal. Multiple bypass capacitors can be paralleled to reject different frequencies of noise. Frequencies of 0.1  $\mu$ F and 1  $\mu$ F are commonly used in parallel. The bypass capacitor must be installed as close as possible to the power terminal for best results.

## 9.4 Layout

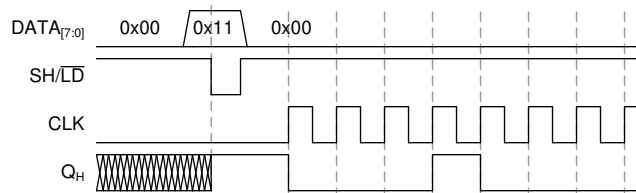
### 9.4.1 Layout Guidelines

When using multiple bit logic devices, inputs should not float. In many cases, functions or parts of functions of digital logic devices are unused. Some examples are when only two inputs of a triple-input AND gate are used, or when only 3 of the 4-buffer gates are used. Such unused input pins must not be left unconnected because the undefined voltages at the outside connections result in undefined operational states. All unused inputs of digital logic devices must be connected to a logic high or logic low voltage, as defined by the input voltage specifications, to prevent them from floating. The logic level that must be applied to any particular unused input depends on the function of the device. Generally, the inputs are tied to GND or  $V_{CC}$ , whichever makes more sense for the logic function or is more convenient.

### 9.4.2 Layout Example



图 9-3. Layout Example for the SN74HC165B-EP in the PW Package

## 10 Device and Documentation Support

### 10.1 Related Documentation

For related documentation, see the following:

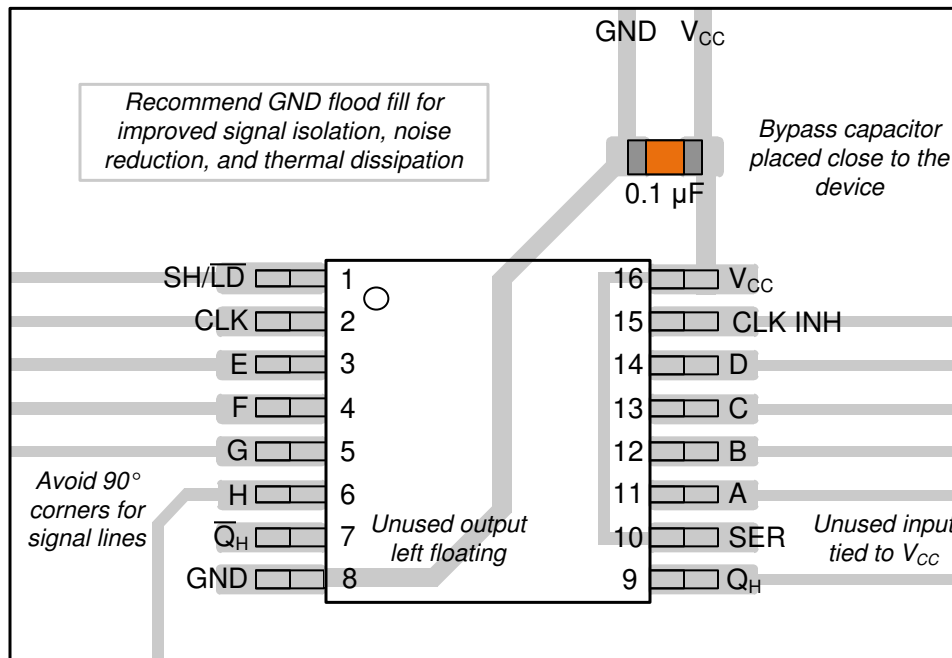
- Texas Instruments, [Power-Up Behavior of Clocked Devices](#)
- Texas Instruments, [Introduction to Logic](#)

### 10.2 Receiving Notification of Documentation Updates

To receive notification of documentation updates—including silicon errata—go to the product folder for your device on [ti.com](#). In the upper right-hand corner, click the *Alert me* button. This registers you to receive a weekly digest of product information that has changed (if any). For change details, check the revision history of any revised document.

### 10.3 支持资源

TI E2E™ 支持论坛是工程师的重要参考资料，可直接从专家获得快速、经过验证的解答和设计帮助。搜索现有解答或提出自己的问题可获得所需的快速设计帮助。

链接的内容由各个贡献者“按原样”提供。这些内容并不构成 TI 技术规范，并且不一定反映 TI 的观点；请参阅 TI 的《使用条款》。

### 10.4 Trademarks

TI E2E™ is a trademark of Texas Instruments.

所有商标均为其各自所有者的财产。

### 10.5 静电放电警告



静电放电 (ESD) 会损坏这个集成电路。德州仪器 (TI) 建议通过适当的预防措施处理所有集成电路。如果不遵守正确的处理和安装程序，可能会损坏集成电路。

ESD 的损坏小至导致微小的性能降级，大至整个器件故障。精密的集成电路可能更容易受到损坏，这是因为非常细微的参数更改都可能会导致器件与其发布的规格不相符。

### 10.6 术语表

TI 术语表 本术语表列出并解释了术语、首字母缩略词和定义。

## 11 Mechanical, Packaging, and Orderable Information

The following pages include mechanical, packaging, and orderable information. This information is the most current data available for the designated devices. This data is subject to change without notice and revision of this document. For browser-based versions of this data sheet, refer to the left-hand navigation.

## PACKAGING INFORMATION

Orderable part number	Status (1)	Material type (2)	Package   Pins	Package qty   Carrier	RoHS (3)	Lead finish/ Ball material (4)	MSL rating/ Peak reflow (5)	Op temp (°C)	Part marking (6)
<a href="#">SN74HC165BMPWREP</a>	Active	Production	TSSOP (PW)   16	3000   LARGE T&R	Yes	NIPDAU	Level-1-260C-UNLIM	-55 to 125	HC165EP
SN74HC165BMPWREP.A	Active	Production	TSSOP (PW)   16	3000   LARGE T&R	Yes	NIPDAU	Level-1-260C-UNLIM	-55 to 125	HC165EP
<a href="#">V62/23621-01XE</a>	Active	Production	TSSOP (PW)   16	3000   LARGE T&R	Yes	NIPDAU	Level-1-260C-UNLIM	-55 to 125	HC165EP

(1) **Status:** For more details on status, see our [product life cycle](#).

(2) **Material type:** When designated, preproduction parts are prototypes/experimental devices, and are not yet approved or released for full production. Testing and final process, including without limitation quality assurance, reliability performance testing, and/or process qualification, may not yet be complete, and this item is subject to further changes or possible discontinuation. If available for ordering, purchases will be subject to an additional waiver at checkout, and are intended for early internal evaluation purposes only. These items are sold without warranties of any kind.

(3) **RoHS values:** Yes, No, RoHS Exempt. See the [TI RoHS Statement](#) for additional information and value definition.

(4) **Lead finish/Ball material:** Parts may have multiple material finish options. Finish options are separated by a vertical ruled line. Lead finish/Ball material values may wrap to two lines if the finish value exceeds the maximum column width.

(5) **MSL rating/Peak reflow:** The moisture sensitivity level ratings and peak solder (reflow) temperatures. In the event that a part has multiple moisture sensitivity ratings, only the lowest level per JEDEC standards is shown. Refer to the shipping label for the actual reflow temperature that will be used to mount the part to the printed circuit board.

(6) **Part marking:** There may be an additional marking, which relates to the logo, the lot trace code information, or the environmental category of the part.

Multiple part markings will be inside parentheses. Only one part marking contained in parentheses and separated by a "-" will appear on a part. If a line is indented then it is a continuation of the previous line and the two combined represent the entire part marking for that device.

**Important Information and Disclaimer:** The information provided on this page represents TI's knowledge and belief as of the date that it is provided. TI bases its knowledge and belief on information provided by third parties, and makes no representation or warranty as to the accuracy of such information. Efforts are underway to better integrate information from third parties. TI has taken and continues to take reasonable steps to provide representative and accurate information but may not have conducted destructive testing or chemical analysis on incoming materials and chemicals. TI and TI suppliers consider certain information to be proprietary, and thus CAS numbers and other limited information may not be available for release.

In no event shall TI's liability arising out of such information exceed the total purchase price of the TI part(s) at issue in this document sold by TI to Customer on an annual basis.

**TAPE AND REEL INFORMATION**

**QUADRANT ASSIGNMENTS FOR PIN 1 ORIENTATION IN TAPE**



\*All dimensions are nominal

Device	Package Type	Package Drawing	Pins	SPQ	Reel Diameter (mm)	Reel Width W1 (mm)	A0 (mm)	B0 (mm)	K0 (mm)	P1 (mm)	W (mm)	Pin1 Quadrant
SN74HC165BMPWREP	TSSOP	PW	16	3000	330.0	12.4	6.9	5.6	1.6	8.0	12.0	Q1

**TAPE AND REEL BOX DIMENSIONS**

\*All dimensions are nominal

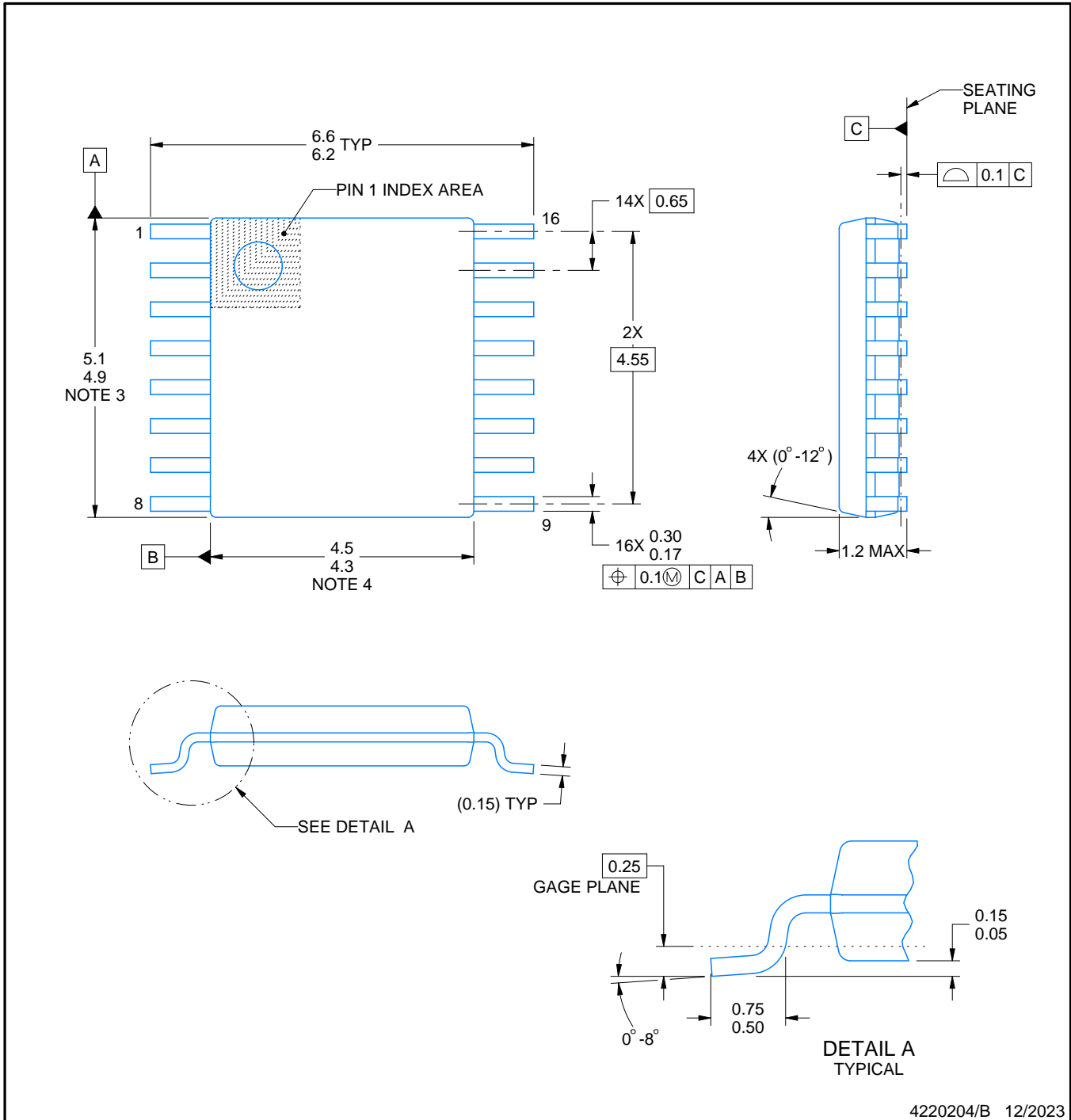
Device	Package Type	Package Drawing	Pins	SPQ	Length (mm)	Width (mm)	Height (mm)
SN74HC165BMPWREP	TSSOP	PW	16	3000	353.0	353.0	32.0



4220204/B 12/2023

NOTES:

1. All linear dimensions are in millimeters. Any dimensions in parenthesis are for reference only. Dimensioning and tolerancing per ASME Y14.5M.
2. This drawing is subject to change without notice.
3. This dimension does not include mold flash, protrusions, or gate burrs. Mold flash, protrusions, or gate burrs shall not exceed 0.15 mm per side.
4. This dimension does not include interlead flash. Interlead flash shall not exceed 0.25 mm per side.
5. Reference JEDEC registration MO-153.

# EXAMPLE BOARD LAYOUT

PW0016A

TSSOP - 1.2 mm max height

SMALL OUTLINE PACKAGE



LAND PATTERN EXAMPLE  
EXPOSED METAL SHOWN  
SCALE: 10X



SOLDER MASK DETAILS

4220204/B 12/2023

NOTES: (continued)

6. Publication IPC-7351 may have alternate designs.
7. Solder mask tolerances between and around signal pads can vary based on board fabrication site.

# EXAMPLE STENCIL DESIGN

PW0016A

TSSOP - 1.2 mm max height

SMALL OUTLINE PACKAGE

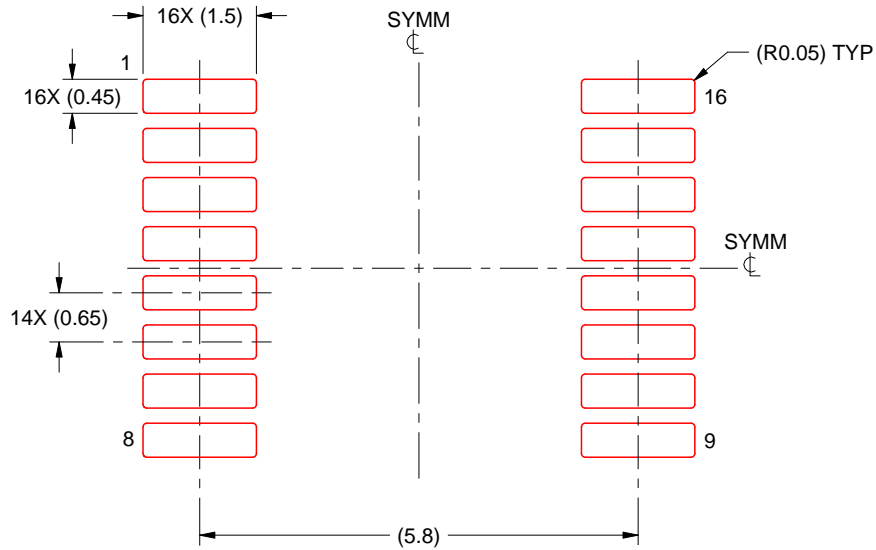

SOLDER PASTE EXAMPLE  
BASED ON 0.125 mm THICK STENCIL  
SCALE: 10X

4220204/B 12/2023

NOTES: (continued)

8. Laser cutting apertures with trapezoidal walls and rounded corners may offer better paste release. IPC-7525 may have alternate design recommendations.
9. Board assembly site may have different recommendations for stencil design.

## 重要通知和免责声明

TI“按原样”提供技术和可靠性数据（包括数据表）、设计资源（包括参考设计）、应用或其他设计建议、网络工具、安全信息和其他资源，不保证没有瑕疵且不做任何明示或暗示的担保，包括但不限于对适销性、与某特定用途的适用性或不侵犯任何第三方知识产权的暗示担保。

这些资源可供使用 TI 产品进行设计的熟练开发人员使用。您将自行承担以下全部责任：(1) 针对您的应用选择合适的 TI 产品，(2) 设计、验证并测试您的应用，(3) 确保您的应用满足相应标准以及任何其他安全、安保法规或其他要求。

这些资源如有变更，恕不另行通知。TI 授权您仅可将这些资源用于研发本资源所述的 TI 产品的相关应用。严禁以其他方式对这些资源进行复制或展示。您无权使用任何其他 TI 知识产权或任何第三方知识产权。对于因您对这些资源的使用而对 TI 及其代表造成的任何索赔、损害、成本、损失和债务，您将全额赔偿，TI 对此概不负责。

TI 提供的产品受 [TI 销售条款](#)、[TI 通用质量指南](#) 或 [ti.com](#) 上其他适用条款或 TI 产品随附的其他适用条款的约束。TI 提供这些资源并不会扩展或以其他方式更改 TI 针对 TI 产品发布的适用的担保或担保免责声明。除非德州仪器 (TI) 明确将某产品指定为定制产品或客户特定产品，否则其产品均为按确定价格收入目录的标准通用器件。

TI 反对并拒绝您可能提出的任何其他或不同的条款。

版权所有 © 2026，德州仪器 (TI) 公司

最后更新日期：2025 年 10 月