

# SN54AS885, SN74AS885 8-BIT MAGNITUDE COMPARATORS

SDAS236A – DECEMBER 1982 – REVISED JANUARY 1995

- Latchable P-Input Ports With Power-Up Clear
- Choice of Logical or Arithmetic (Two's Complement) Comparison
- Data and PLE Inputs Utilize pnp Input Transistors to Reduce dc Loading Effects
- Approximately 35% Improvement in ac Performance Over Schottky TTL While Performing More Functions
- Cascadable to n Bits While Maintaining High Performance
- 10% Less Power Than STTL for an 8-Bit Comparison
- Package Options Include Plastic Small-Outline (DW) Packages, Ceramic Chip Carriers (FK), and Standard Plastic (NT) and Ceramic (JT) 300-mil DIPs

## description

These advanced Schottky devices are capable of performing high-speed arithmetic or logic comparisons on two 8-bit binary or two's complement words. Two fully decoded decisions about words P and Q are externally available at two outputs. These devices are fully expandable to any number of bits without external gates. To compare words of longer lengths, the P > QOUT and P < QOUT outputs of a stage handling less significant bits can be connected to the P > QIN and P < QIN inputs of the next stage handling more significant bits. The cascading paths are implemented with only a two-gate-level delay to reduce overall comparison times for long words. Two alternative methods of cascading are shown in *application information*.

The latch is transparent when P latch-enable (PLE) input is high; the P-input port is latched when PLE is low. This provides the designer with temporary storage for the P-data word. The enable circuitry is implemented with minimal delay times to enhance performance when cascaded for longer words. The PLE, P, and Q data inputs utilize pnp input transistors to reduce the low-level current input requirement to typically -0.25 mA, which minimizes dc loading effects.

The SN54AS885 is characterized for operation over the full military temperature range of -55°C to 125°C. The SN74AS885 is characterized for operation from 0°C to 70°C.

SN54AS885 . . . JT PACKAGE  
SN74AS885 . . . DW OR NT PACKAGE  
(TOP VIEW)

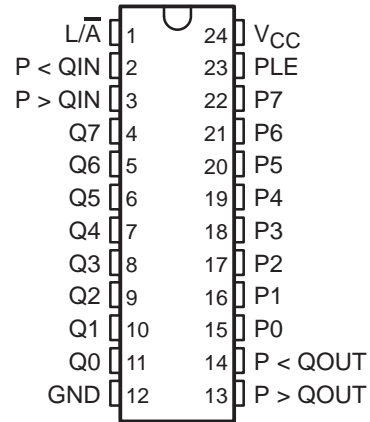

SN54AS885 . . . FK PACKAGE  
(TOP VIEW)

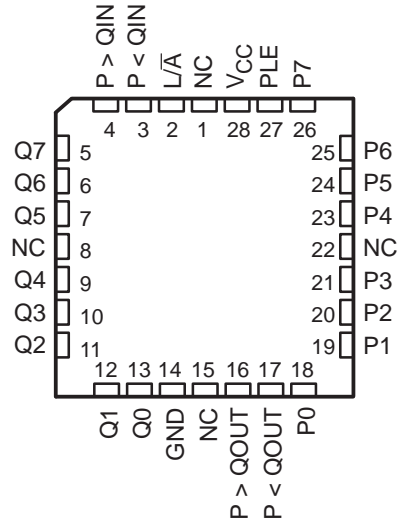

NC – No internal connection

# SN54AS885, SN74AS885 8-BIT MAGNITUDE COMPARATORS

SDAS236A – DECEMBER 1982 – REVISED JANUARY 1995

FUNCTION TABLE

COMPARISON	INPUTS				OUTPUTS	
	$\overline{L/A}$	DATA P0–P7, Q0–Q7	P > QIN	P < QIN	P > QOUT	P < QOUT
Logical	H	P > Q	X	X	H	L
Logical	H	P < Q	X	X	L	H
Logical†	H	P = Q	H or L	H or L	H or L	H or L
Arithmetic	L	P AG Q	X	X	H	L
Arithmetic	L	Q AG P	X	X	L	H
Arithmetic†	L	P = Q	H or L	H or L	H or L	H or L

† In these cases, P > QOUT follows P > QIN and P < QOUT follows P < QIN.  
AG = arithmetically greater than

## logic symbol‡

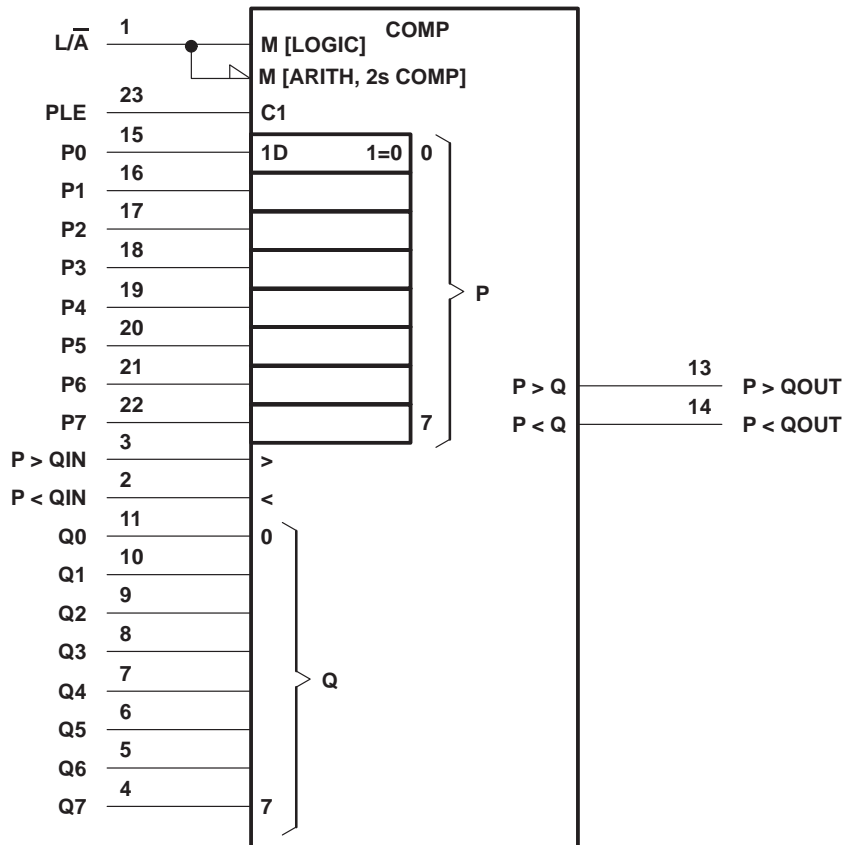

‡ This symbol is in accordance with ANSI/IEEE Std 91-1984 and IEC Publication 617-12.  
Pin numbers shown are for the DW, JT, and NT packages.

# SN54AS885, SN74AS885 8-BIT MAGNITUDE COMPARATORS

SDAS236A – DECEMBER 1982 – REVISED JANUARY 1995

## logic diagram (positive logic)

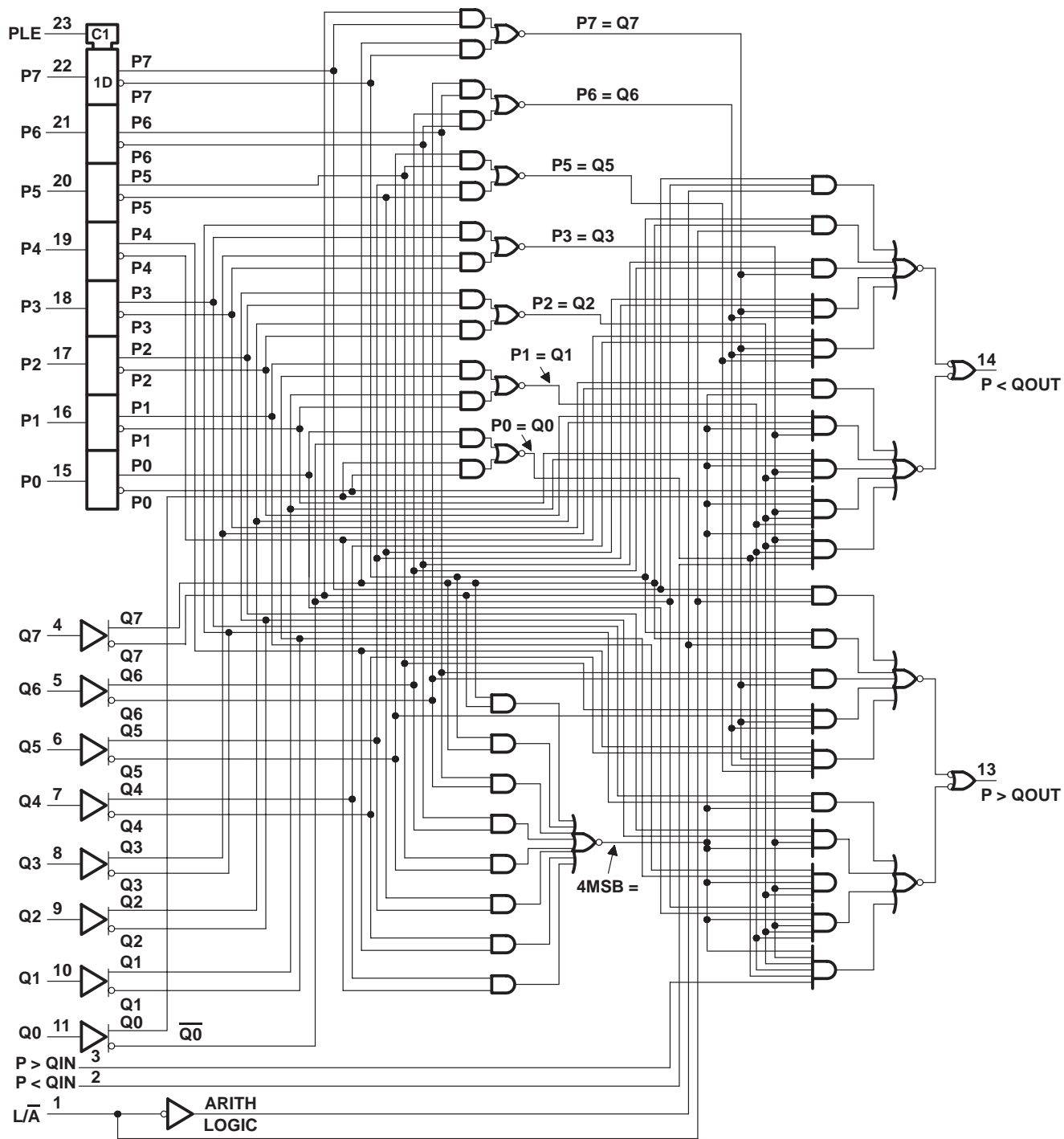

Pin numbers shown are for the DW, JT, and NT packages.



# SN54AS885, SN74AS885 8-BIT MAGNITUDE COMPARATORS

SDAS236A – DECEMBER 1982 – REVISED JANUARY 1995

## absolute maximum ratings over operating free-air temperature range (unless otherwise noted)†

Supply voltage, $V_{CC}$	7 V
Input voltage, $V_I$	7 V
Operating free-air temperature range, $T_A$ : SN54AS885	-55°C to 125°C
SN74AS885	0°C to 70°C
Storage temperature range	-65°C to 150°C

† Stresses beyond those listed under “absolute maximum ratings” may cause permanent damage to the device. These are stress ratings only, and functional operation of the device at these or any other conditions beyond those indicated under “recommended operating conditions” is not implied. Exposure to absolute-maximum-rated conditions for extended periods may affect device reliability.

## recommended operating conditions

		SN54AS885			SN74AS885			UNIT
		MIN	NOM	MAX	MIN	NOM	MAX	
$V_{CC}$	Supply voltage	4.5	5	5.5	4.5	5	5.5	V
$V_{IH}$	High-level input voltage	2			2			V
$V_{IL}$	Low-level input voltage			0.8			0.8	V
$I_{OH}$	High-level output current			-2			-2	mA
$I_{OL}$	Low-level output current			20			20	mA
$t_{su}^*$	Setup time, data before PLE↓	2			2			ns
$t_h^*$	Hold time, data after PLE↓	4.5			4			ns
$T_A$	Operating free-air temperature	-55		125	0		70	°C

\* On products compliant to MIL-STD-883, Class B, this parameter is based on characterization data but is not production tested.

## electrical characteristics over recommended operating free-air temperature range (unless otherwise noted)

PARAMETER	TEST CONDITIONS	SN54AS885			SN74AS885			UNIT
		MIN	TYP‡	MAX	MIN	TYP‡	MAX	
$V_{IK}$	$V_{CC} = 4.5 V$ , $I_I = -18 mA$			-1.2			-1.2	V
$V_{OH}$	$V_{CC} = 4.5 V$ to $5.5 V$ , $I_{OH} = -2 mA$	$V_{CC} - 2$			$V_{CC} - 2$			V
$V_{OL}$	$V_{CC} = 4.5 V$ , $I_{OL} = 20 mA$	0.35	0.5		0.35	0.5		V
$I_I$	$V_{CC} = 5.5 V$ , $V_I = 7 V$		0.1			0.1		mA
$I_{IH}$	$L/\bar{A}$		40			40		$\mu A$
	Others		20			20		
$I_{IL}$	$L/\bar{A}$		-4			-4		mA
	$P > QIN, P < QIN$		-2			-2		
	$P, Q, PLE$		-1			-1		
$I_{O}^{\S}$	$V_{CC} = 5.5 V$ , $V_O = 2.25 V$	-20		-112	-20		-112	mA
$I_{CC}$	$V_{CC} = 5.5 V$ , See Note 1		130	210		130	210	mA

‡ All typical values are at  $V_{CC} = 5 V$ ,  $T_A = 25^\circ C$ .

§ The output conditions have been chosen to produce a current that closely approximates one half of the true short-circuit output current,  $I_{OS}$ .

NOTE 1:  $I_{CC}$  is measured with all inputs high except  $L/\bar{A}$ , which is low.



**switching characteristics (see Figure 3)**

PARAMETER	FROM (INPUT)	TO (OUTPUT)	V <sub>CC</sub> = 4.5 V to 5.5 V, C <sub>L</sub> = 50 pF, R <sub>L</sub> = 500 Ω, T <sub>A</sub> = MIN to MAX						UNIT
			SN54AS885			SN74AS885			
			MIN	TYP†	MAX	MIN	TYP†	MAX	
t <sub>PLH</sub>	L/ $\bar{A}$	P < QOUT, P > QOUT	2	8.5	14	1	8.5	13	ns
t <sub>PHL</sub>			2	7.5	14	1	7.5	13	
t <sub>PLH</sub>	P < QIN, P > QIN	P < QOUT, P > QOUT	2	5	10	1	5	8	ns
t <sub>PHL</sub>			2	5.5	10	1	5.5	8	
t <sub>PLH</sub>	Any P or Q data input	P < QOUT, P > QOUT	2	13.5	21	1	13.5	17.5	ns
t <sub>PHL</sub>			2	10	17	1	10	15	

† All typical values are at V<sub>CC</sub> = 5 V, T<sub>A</sub> = 25°C.

**APPLICATION INFORMATION**

The 'AS885 can be cascaded to compare words longer than eight bits. Figure 1 shows the comparison of two 32-bit words; however, the design is expandable to n bits. Figure 1 shows the optimum cascading arrangement for comparing words of 32 bits or greater. Typical delay times shown are at V<sub>CC</sub> = 5 V, T<sub>A</sub> = 25°C and use the standard advanced Schottky load of R<sub>L</sub> = 500 Ω, C<sub>L</sub> = 50 pF.

Figure 2 shows the fastest cascading arrangement for comparing 16-bit or 24-bit words. Typical delay times shown are at V<sub>CC</sub> = 5 V, T<sub>A</sub> = 25°C and use the standard advanced Schottky load of R<sub>L</sub> = 500 Ω, C<sub>L</sub> = 50 pF.

# SN54AS885, SN74AS885 8-BIT MAGNITUDE COMPARATORS

SDAS236A – DECEMBER 1982 – REVISED JANUARY 1995

## APPLICATION INFORMATION

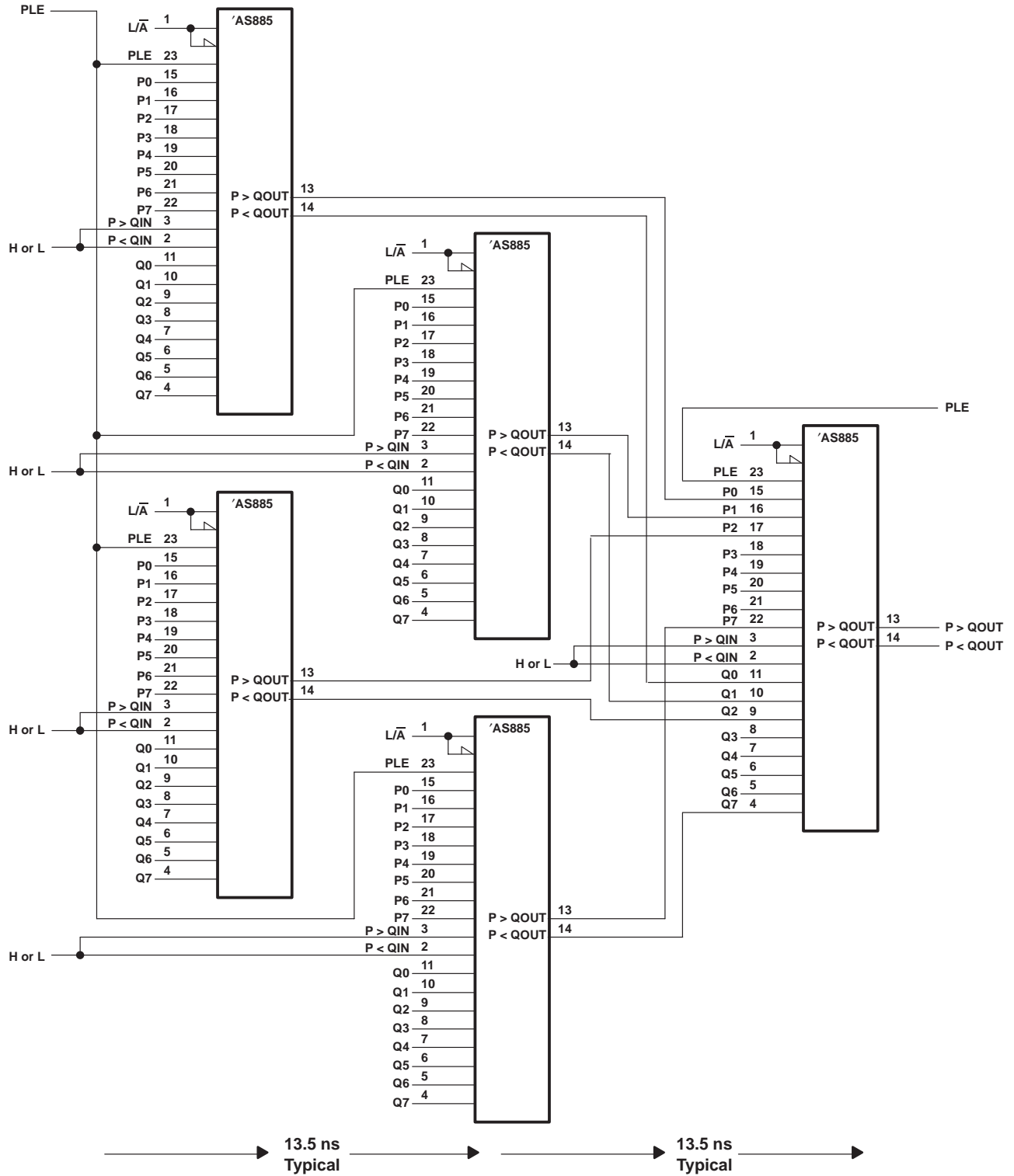

Figure 1. 32-Bit to 72 (n)-Bit Magnitude Comparator

APPLICATION INFORMATION

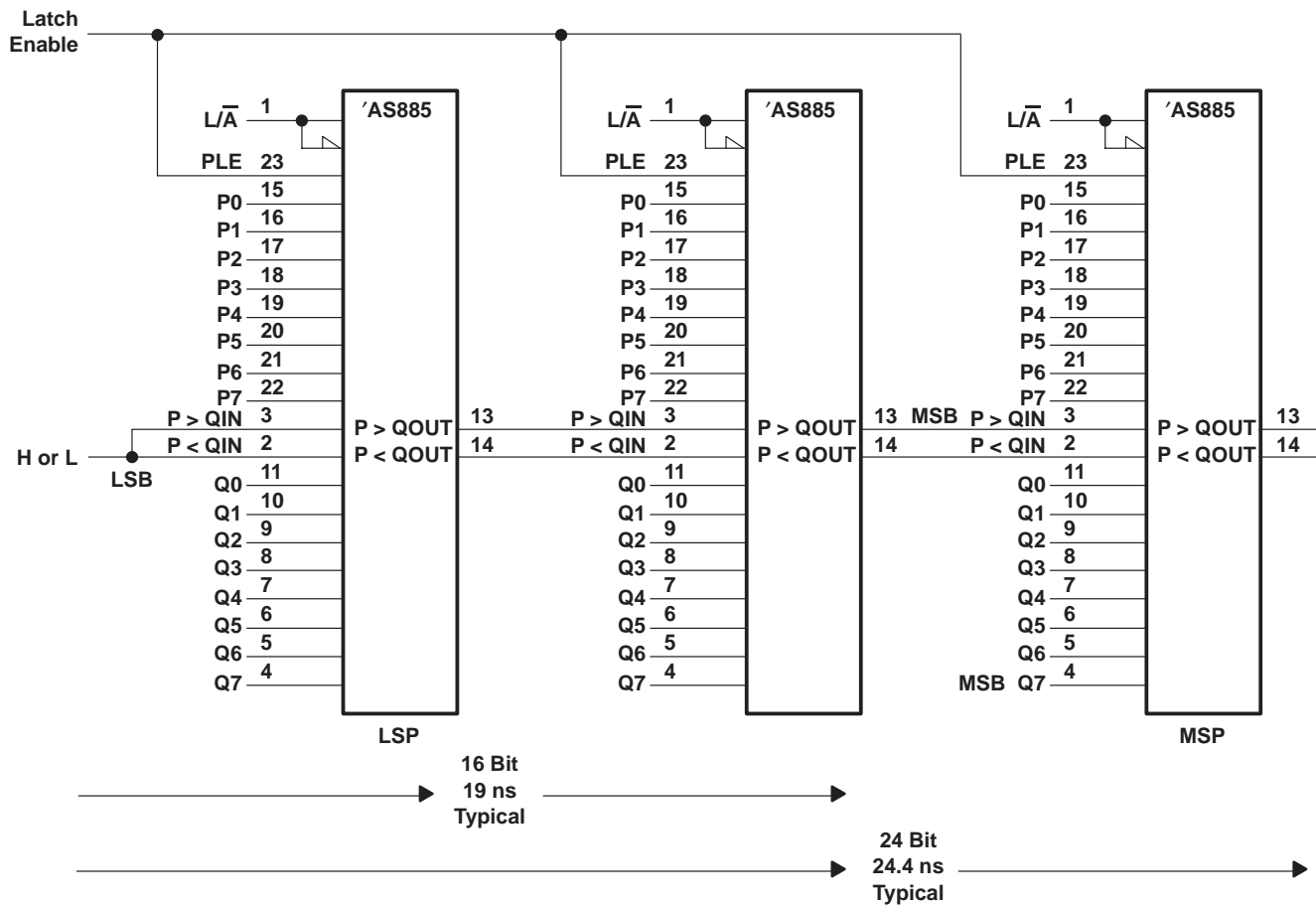
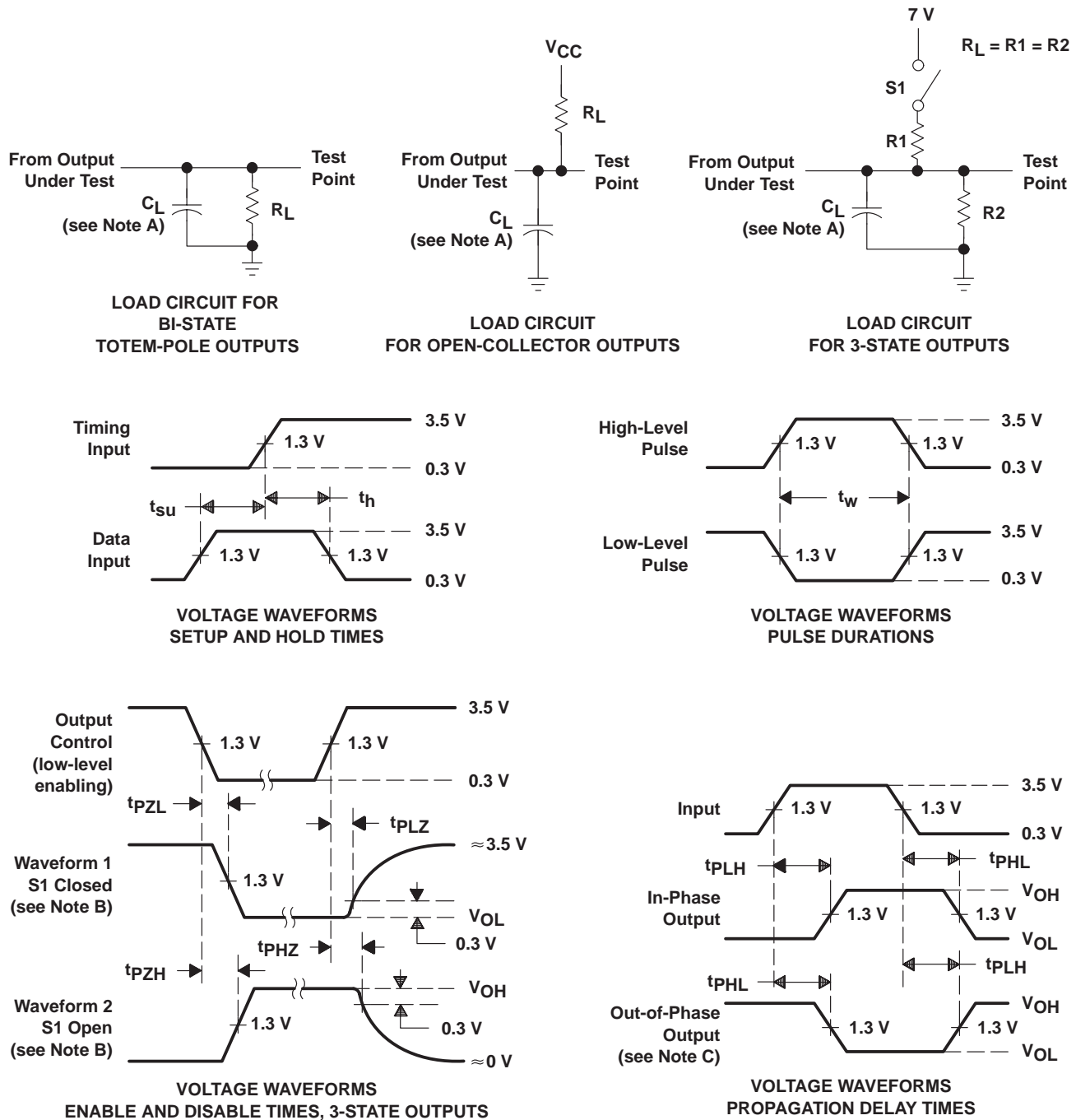

Figure 2. Fastest Cascading Arrangement for Comparing 16-Bit or 24-Bit Words

# SN54AS885, SN74AS885 8-BIT MAGNITUDE COMPARATORS

SDAS236A – DECEMBER 1982 – REVISED JANUARY 1995

## PARAMETER MEASUREMENT INFORMATION SERIES 54ALS/74ALS AND 54AS/74AS DEVICES



- NOTES: A.  $C_L$  includes probe and jig capacitance.  
 B. Waveform 1 is for an output with internal conditions such that the output is low except when disabled by the output control. Waveform 2 is for an output with internal conditions such that the output is high except when disabled by the output control.  
 C. When measuring propagation delay items of 3-state outputs, switch S1 is open.  
 D. All input pulses have the following characteristics:  $PRR \leq 1$  MHz,  $t_r = t_f = 2$  ns, duty cycle = 50%.  
 E. The outputs are measured one at a time with one transition per measurement.

Figure 3. Load Circuits and Voltage Waveforms

**PACKAGING INFORMATION**

Orderable part number	Status (1)	Material type (2)	Package   Pins	Package qty   Carrier	RoHS (3)	Lead finish/ Ball material (4)	MSL rating/ Peak reflow (5)	Op temp (°C)	Part marking (6)
<a href="#">5962-89757013A</a>	Active	Production	LCCC (FK)   28	42   TUBE	No	SNPB	N/A for Pkg Type	-55 to 125	5962- 89757013A SNJ54AS 885FK
<a href="#">5962-8975701LA</a>	Active	Production	CDIP (JT)   24	15   TUBE	No	SNPB	N/A for Pkg Type	-55 to 125	5962-8975701LA SNJ54AS885JT
<a href="#">SN54AS885JT</a>	Active	Production	CDIP (JT)   24	15   TUBE	No	SNPB	N/A for Pkg Type	-55 to 125	SN54AS885JT
SN54AS885JT.A	Active	Production	CDIP (JT)   24	15   TUBE	No	SNPB	N/A for Pkg Type	-55 to 125	SN54AS885JT
<a href="#">SN74AS885DW</a>	Active	Production	SOIC (DW)   24	25   TUBE	Yes	NIPDAU	Level-1-260C-UNLIM	0 to 70	AS885
SN74AS885DW.A	Active	Production	SOIC (DW)   24	25   TUBE	Yes	NIPDAU	Level-1-260C-UNLIM	0 to 70	AS885
<a href="#">SNJ54AS885FK</a>	Active	Production	LCCC (FK)   28	42   TUBE	No	SNPB	N/A for Pkg Type	-55 to 125	5962- 89757013A SNJ54AS 885FK
SNJ54AS885FK.A	Active	Production	LCCC (FK)   28	42   TUBE	No	SNPB	N/A for Pkg Type	-55 to 125	5962- 89757013A SNJ54AS 885FK
<a href="#">SNJ54AS885JT</a>	Active	Production	CDIP (JT)   24	15   TUBE	No	SNPB	N/A for Pkg Type	-55 to 125	5962-8975701LA SNJ54AS885JT
SNJ54AS885JT.A	Active	Production	CDIP (JT)   24	15   TUBE	No	SNPB	N/A for Pkg Type	-55 to 125	5962-8975701LA SNJ54AS885JT

(1) **Status:** For more details on status, see our [product life cycle](#).

(2) **Material type:** When designated, preproduction parts are prototypes/experimental devices, and are not yet approved or released for full production. Testing and final process, including without limitation quality assurance, reliability performance testing, and/or process qualification, may not yet be complete, and this item is subject to further changes or possible discontinuation. If available for ordering, purchases will be subject to an additional waiver at checkout, and are intended for early internal evaluation purposes only. These items are sold without warranties of any kind.

(3) **RoHS values:** Yes, No, RoHS Exempt. See the [TI RoHS Statement](#) for additional information and value definition.

(4) **Lead finish/Ball material:** Parts may have multiple material finish options. Finish options are separated by a vertical ruled line. Lead finish/Ball material values may wrap to two lines if the finish value exceeds the maximum column width.

<sup>(5)</sup> **MSL rating/Peak reflow:** The moisture sensitivity level ratings and peak solder (reflow) temperatures. In the event that a part has multiple moisture sensitivity ratings, only the lowest level per JEDEC standards is shown. Refer to the shipping label for the actual reflow temperature that will be used to mount the part to the printed circuit board.

<sup>(6)</sup> **Part marking:** There may be an additional marking, which relates to the logo, the lot trace code information, or the environmental category of the part.

Multiple part markings will be inside parentheses. Only one part marking contained in parentheses and separated by a "~" will appear on a part. If a line is indented then it is a continuation of the previous line and the two combined represent the entire part marking for that device.

**Important Information and Disclaimer:** The information provided on this page represents TI's knowledge and belief as of the date that it is provided. TI bases its knowledge and belief on information provided by third parties, and makes no representation or warranty as to the accuracy of such information. Efforts are underway to better integrate information from third parties. TI has taken and continues to take reasonable steps to provide representative and accurate information but may not have conducted destructive testing or chemical analysis on incoming materials and chemicals. TI and TI suppliers consider certain information to be proprietary, and thus CAS numbers and other limited information may not be available for release.

In no event shall TI's liability arising out of such information exceed the total purchase price of the TI part(s) at issue in this document sold by TI to Customer on an annual basis.

**OTHER QUALIFIED VERSIONS OF SN54AS885, SN74AS885 :**

- Catalog : [SN74AS885](#)
- Military : [SN54AS885](#)

NOTE: Qualified Version Definitions:

- Catalog - TI's standard catalog product
- Military - QML certified for Military and Defense Applications

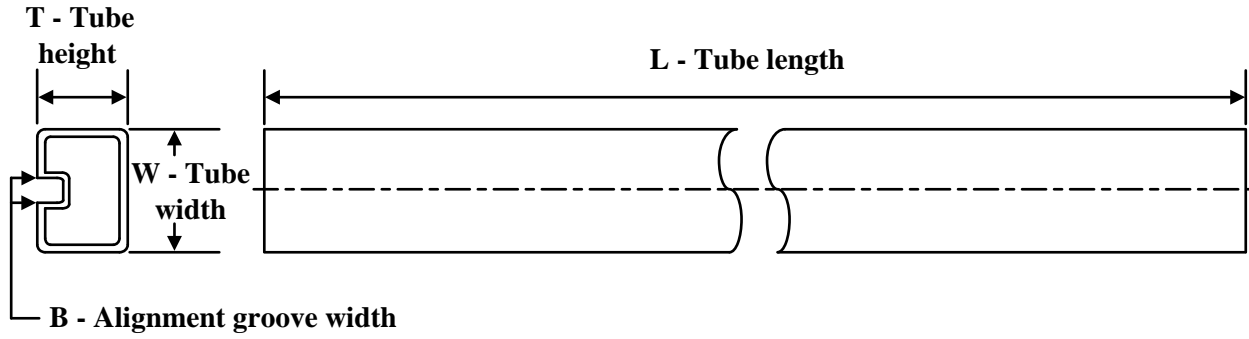
**TUBE**

\*All dimensions are nominal

Device	Package Name	Package Type	Pins	SPQ	L (mm)	W (mm)	T (μm)	B (mm)
SN74AS885DW	DW	SOIC	24	25	506.98	12.7	4826	6.6
SN74AS885DW.A	DW	SOIC	24	25	506.98	12.7	4826	6.6

JT (R-GDIP-T\*\*)

CERAMIC DUAL-IN-LINE

24 LEADS SHOWN



- NOTES: A. All linear dimensions are in inches (millimeters).  
 B. This drawing is subject to change without notice.  
 C. This package can be hermetically sealed with a ceramic lid using glass frit.  
 D. Index point is provided on cap for terminal identification.  
 E. Falls within MIL STD 1835 GDIP3-T24, GDIP4-T28, and JEDEC MO-058 AA, MO-058 AB

FK (S-CQCC-N\*\*)

LEADLESS CERAMIC CHIP CARRIER

28 TERMINAL SHOWN



NO. OF TERMINALS **	A		B	
	MIN	MAX	MIN	MAX
20	0.342 (8,69)	0.358 (9,09)	0.307 (7,80)	0.358 (9,09)
28	0.442 (11,23)	0.458 (11,63)	0.406 (10,31)	0.458 (11,63)
44	0.640 (16,26)	0.660 (16,76)	0.495 (12,58)	0.560 (14,22)
52	0.740 (18,78)	0.761 (19,32)	0.495 (12,58)	0.560 (14,22)
68	0.938 (23,83)	0.962 (24,43)	0.850 (21,6)	0.858 (21,8)
84	1.141 (28,99)	1.165 (29,59)	1.047 (26,6)	1.063 (27,0)



4040140/D 01/11

- NOTES:
- All linear dimensions are in inches (millimeters).
  - This drawing is subject to change without notice.
  - This package can be hermetically sealed with a metal lid.
  - Falls within JEDEC MS-004

DW (R-PDSO-G24)

PLASTIC SMALL OUTLINE



- NOTES:
- A. All linear dimensions are in inches (millimeters). Dimensioning and tolerancing per ASME Y14.5M-1994.
  - B. This drawing is subject to change without notice.
  - C. Body dimensions do not include mold flash or protrusion not to exceed 0.006 (0,15).
  - D. Falls within JEDEC MS-013 variation AD.

## IMPORTANT NOTICE AND DISCLAIMER

TI PROVIDES TECHNICAL AND RELIABILITY DATA (INCLUDING DATASHEETS), DESIGN RESOURCES (INCLUDING REFERENCE DESIGNS), APPLICATION OR OTHER DESIGN ADVICE, WEB TOOLS, SAFETY INFORMATION, AND OTHER RESOURCES "AS IS" AND WITH ALL FAULTS, AND DISCLAIMS ALL WARRANTIES, EXPRESS AND IMPLIED, INCLUDING WITHOUT LIMITATION ANY IMPLIED WARRANTIES OF MERCHANTABILITY, FITNESS FOR A PARTICULAR PURPOSE OR NON-INFRINGEMENT OF THIRD PARTY INTELLECTUAL PROPERTY RIGHTS.

These resources are intended for skilled developers designing with TI products. You are solely responsible for (1) selecting the appropriate TI products for your application, (2) designing, validating and testing your application, and (3) ensuring your application meets applicable standards, and any other safety, security, regulatory or other requirements.

These resources are subject to change without notice. TI grants you permission to use these resources only for development of an application that uses the TI products described in the resource. Other reproduction and display of these resources is prohibited. No license is granted to any other TI intellectual property right or to any third party intellectual property right. TI disclaims responsibility for, and you fully indemnify TI and its representatives against any claims, damages, costs, losses, and liabilities arising out of your use of these resources.

TI's products are provided subject to [TI's Terms of Sale](#), [TI's General Quality Guidelines](#), or other applicable terms available either on [ti.com](http://ti.com) or provided in conjunction with such TI products. TI's provision of these resources does not expand or otherwise alter TI's applicable warranties or warranty disclaimers for TI products. Unless TI explicitly designates a product as custom or customer-specified, TI products are standard, catalog, general purpose devices.

TI objects to and rejects any additional or different terms you may propose.

Copyright © 2026, Texas Instruments Incorporated

Last updated 10/2025