

## SNx4AHCT126 具有三态输出的四路总线缓冲门

### 1 特性

- 输入兼容 TTL 电压
- 闩锁性能超过 250mA，符合 JESD 17 规范
- ESD 保护性能超过 JESD 22 规范要求：
  - 2000V 人体放电模型 (A114-A)
  - 200V 机器放电模型 (A115-A)
- 对于符合 MIL-PRF-38535 标准的产品，所有参数均经过测试，除非另有说明。对于所有其他产品，生产流程不一定包含对所有参数的测试。

### 2 应用

- 服务器
- PC 和笔记本电脑
- 网络交换机
- 可穿戴保健和健身设备
- 电信基础设施
- 电子销售终端

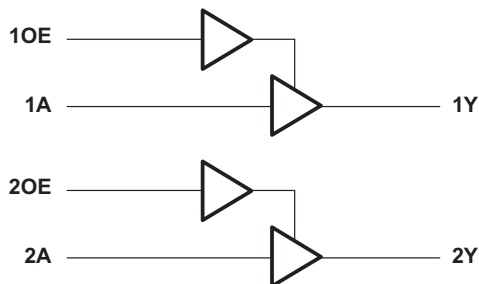

### 3 说明

SNxAHCT126 器件是四通道总线缓冲门，采用具有三态输出的独立线路驱动器。

器件信息

器件型号	等级	封装尺寸 <sup>(1)</sup>
SN54AHCT126	军用级	D ( SOIC , 14 )
		DB ( SSOP , 14 )
		DGV ( TVSOP , 14 )
SN74AHCT126	商用级	NS ( PDIP , 14 )
		N ( SOP , 14 )
		PW ( TSSOP , 14 )
		J ( CDIP , 14 )
		W ( CFP , 14 )
		BQA ( WQFN , 14 )
FK ( LCCC , 20 )		

(1) 更多相关信息，请参阅第 11 节。

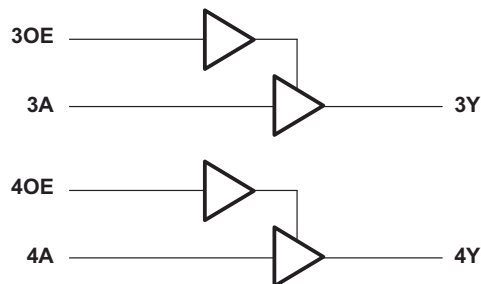

简化原理图



## Table of Contents

<b>1 特性</b> .....	<b>1</b>	7.2 Functional Block Diagram.....	<b>10</b>
<b>2 应用</b> .....	<b>1</b>	7.3 Feature Description.....	<b>10</b>
<b>3 说明</b> .....	<b>1</b>	7.4 Device Functional Modes.....	<b>10</b>
<b>4 Pin Configuration and Functions</b> .....	<b>3</b>	<b>8 Application and Implementation</b> .....	<b>11</b>
<b>5 Specifications</b> .....	<b>5</b>	8.1 Application Information.....	<b>11</b>
5.1 Absolute Maximum Ratings.....	<b>5</b>	8.2 Typical Application.....	<b>11</b>
5.2 ESD Ratings.....	<b>5</b>	8.3 Power Supply Recommendations.....	<b>12</b>
5.3 Recommended Operating Conditions.....	<b>5</b>	8.4 Layout.....	<b>12</b>
5.4 Thermal Information.....	<b>6</b>	<b>9 Device and Documentation Support</b> .....	<b>13</b>
5.5 Electrical Characteristics.....	<b>6</b>	9.1 接收文档更新通知.....	<b>13</b>
5.6 Switching Characteristics, $V_{CC} = 5\text{ V} \pm 0.5\text{ V}$ .....	<b>7</b>	9.2 支持资源.....	<b>13</b>
5.7 Noise Characteristics.....	<b>7</b>	9.3 Trademarks.....	<b>13</b>
5.8 Operating Characteristics.....	<b>7</b>	9.4 静电放电警告.....	<b>13</b>
5.9 Typical Characteristics.....	<b>8</b>	9.5 术语表.....	<b>13</b>
<b>6 Parameter Measurement Information</b> .....	<b>9</b>	<b>10 Revision History</b> .....	<b>13</b>
<b>7 Detailed Description</b> .....	<b>10</b>	<b>11 Mechanical, Packaging, and Orderable Information</b> .....	<b>13</b>
7.1 Overview.....	<b>10</b>		

## 4 Pin Configuration and Functions



图 4-1. SN54AHCT126 J or W Packages, CDIP or CFP

SN74AHCT126 D, DB, DGV, N, NS, or PW Packages, 14-Pin SOIC, SSOP, TVSOP, PDIP, SOP or TSSOP (Top View)

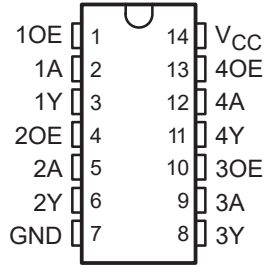
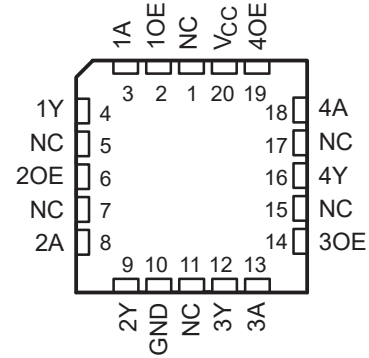

NC - No internal connection

图 4-2. SN54AHCT126 FK Package, 20-Pin LCCC (Top View)



图 4-3. SNx4AHCT126 BQA Package, 14-Pin WQFN (Top View)

表 4-1. Pin Functions

NAME	PIN			TYPE <sup>(1)</sup>	DESCRIPTION
	SN74AHCT126 D, DB, DGV, N, NS, PW, BQA	SN54AHCT126 J, W	FK		
1A	2	2	3	I	1A Input
1OE	1	1	2	I	Output Enable 1
1Y	3	3	4	O	1Y Output
2A	5	5	8	I	2A Input
2OE	4	4	6	I	Output Enable 2
2Y	6	6	9	O	2Y Output
3A	9	9	13	I	3A Input
3OE	10	10	14	I	Output Enable 3
3Y	8	8	12	O	3Y Output
4A	12	12	18	I	4A Input
4OE	13	13	19	I	Output Enable 4
4Y	11	11	16	O	4Y Output
GND	7	7	10	—	Ground Pin

表 4-1. Pin Functions (续)

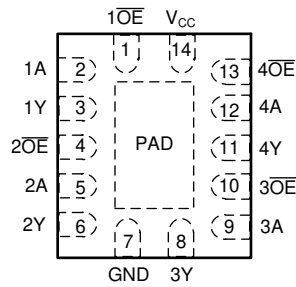
NAME	PIN		TYPE <sup>(1)</sup>	DESCRIPTION
	SN74AHCT126 D, DB, DGV, N, NS, PW, BQA	SN54AHCT126 J, W FK		
NC		—	1	— No Connection
			5	
			7	
			11	
			15	
			17	
V <sub>CC</sub>	14	14	20	— Power Pin
Thermal Pad <sup>(2)</sup>				— Thermal Pad

- (1) I = input, O = output
- (2) For BQA package only

## 5 Specifications

### 5.1 Absolute Maximum Ratings

over operating free-air temperature range (unless otherwise noted)<sup>(1)</sup>

		MIN	MAX	UNIT
V <sub>CC</sub>	Supply voltage range	- 0.5	7	V
V <sub>I</sub>	Input voltage range <sup>(2)</sup>	- 0.5	7	V
V <sub>O</sub>	Output voltage range <sup>(2)</sup>	- 0.5	V <sub>CC</sub> + 0.5	V
I <sub>IK</sub>	Input clamp current	V <sub>I</sub> < 0	- 20	mA
I <sub>OK</sub>	Output clamp current	V <sub>O</sub> < 0 or V <sub>O</sub> > V <sub>CC</sub>	±20	mA
I <sub>O</sub>	Continuous output current	V <sub>O</sub> = 0 to V <sub>CC</sub>	±25	mA
Continuous current through V <sub>CC</sub> or GND			±50	mA

- (1) Stresses beyond those listed under *Absolute Maximum Ratings* may cause permanent damage to the device. These are stress ratings only, which do not imply functional operation of the device at these or any other conditions beyond those indicated under *Recommended Operating Conditions*. Exposure to absolute-maximum-rated conditions for extended periods may affect device reliability.
- (2) The input and output voltage ratings may be exceeded if the input and output current ratings are observed.

### 5.2 ESD Ratings

		MIN	MAX	UNIT
T <sub>stg</sub>	Storage temperature range	- 65	150	°C
V <sub>(ESD)</sub>	Electrostatic discharge	Human body model (HBM), per ANSI/ESDA/JEDEC JS-001, all pins <sup>(1)</sup>		V

- (1) JEDEC document JEP155 states that 500-V HBM allows safe manufacturing with a standard ESD control process.

### 5.3 Recommended Operating Conditions

over operating free-air temperature range (unless otherwise noted)<sup>(2)</sup>

		SN54AHCT126 <sup>(1)</sup>		SN74AHCT126		UNIT
		MIN	MAX	MIN	MAX	
V <sub>CC</sub>	Supply voltage	4.5	5.5	4.5	5.5	V
V <sub>IH</sub>	High-level input voltage	2		2		V
V <sub>IL</sub>	Low-level input voltage		0.8		0.8	V
V <sub>I</sub>	Input voltage	0	5.5	0	5.5	V
V <sub>O</sub>	Output voltage	0	V <sub>CC</sub>	0	V <sub>CC</sub>	V
I <sub>OH</sub>	High-level output current		- 8		- 8	mA
I <sub>OL</sub>	Low-level output current		8		8	mA
Δt / Δv	Input transition rise or fall rate		20		20	ns/V
T <sub>A</sub>	Operating free-air temperature	- 55	125	- 40	125	°C

- (1) Product Preview.
- (2) All unused inputs of the device must be held at V<sub>CC</sub> or GND for proper device operation. Refer to the TI Application Report, *Implications of Slow or Floating CMOS Inputs (SCBA004)*.

## 5.4 Thermal Information

THERMAL METRIC <sup>(1)</sup>		SN74AHCT126							UNIT
		D	DB	DGV	N	NS	PW	BQA	
		14 PINS							
$R_{\theta JA}$	Junction-to-ambient thermal resistance	124.5	107.1	129.0	57.4	120.9	147.7	88.3	°C/W
$R_{\theta JC(top)}$	Junction-to-case (top) thermal resistance	78.8	59.6	52.1	44.9	78.2	77.4	90.9	
$R_{\theta JB}$	Junction-to-board thermal resistance	81	54.4	62.0	37.2	81.6	90.9	56.8	
$\psi_{JT}$	Junction-to-top characterization parameter	37	20.5	6.5	30.1	42.8	27.2	9.9	
$\psi_{JB}$	Junction-to-board characterization parameter	80.6	53.8	61.3	37.1	81.1	90.2	56.7	
$R_{\theta JC(bot)}$	Junction-to-case (bottom) thermal resistance	N/A	N/A	N/A	N/A	N/A	N/A	33.4	

(1) For more information about traditional and new thermal metrics, see the *IC Package Thermal Metrics* application report (SPRA953).

## 5.5 Electrical Characteristics

over recommended operating free-air temperature range (unless otherwise noted)

PARAMETER	TEST CONDITIONS	$V_{CC}$	$T_A = 25^\circ\text{C}$			SN54AHCT126		SN74AHCT126		SN74AHCT126 - 40 to 125°C		UNIT
			MIN	TYP	MAX	MIN	MAX	MIN	MAX	MIN	MAX	
$V_{OH}$	$I_{OH} = -50 \mu\text{A}$	4.5 V	4.4	4.5		4.4		4.4		4.4	V	
	$I_{OH} = -8 \text{ mA}$		3.94			3.8		3.8		3.8		
$V_{OL}$	$I_{OL} = 50 \mu\text{A}$	4.5 V			0.1		0.1		0.1		0.1	V
	$I_{OL} = 8 \text{ mA}$				0.36		0.44		0.44		0.44	
$I_I$	$V_I = 5.5 \text{ V or GND}$	0 V to 5.5 V			$\pm 0.1$		$\pm 1^{(1)}$		$\pm 1$		$\pm 1$	$\mu\text{A}$
$I_{OZ}$	$V_O = V_{CC} \text{ or GND}$	5.5 V			$\pm 0.25$		$\pm 2.5$		$\pm 2.5$		$\pm 2.5$	$\mu\text{A}$
$I_{CC}$	$V_I = V_{CC} \text{ or GND } I_O = 0$	5.5 V			2		20		20		20	$\mu\text{A}$
$\Delta I_{CC}^{(2)}$	One input at 3.4 V, Other inputs at $V_{CC}$ or GND	5.5 V			1.35		1.5		1.5		1.5	mA
$C_i$	$V_I = V_{CC} \text{ or GND}$	5 V			4				10			pF
$C_o$	$V_O = V_{CC} \text{ or GND}$	5 V			15							pF

(1) On products compliant to MIL-PRF-38535, this parameter is not production tested at  $V_{CC} = 0 \text{ V}$ .

(2) This is the increase in supply current for each input at one of the specified TTL voltage levels, rather than 0 V or  $V_{CC}$ .

## 5.6 Switching Characteristics, $V_{CC} = 5\text{ V} \pm 0.5\text{ V}$

over recommended operating free-air temperature range (unless otherwise noted) (see [图 6-1](#))

PARAMETER	FROM (OUTPUT)	TO (INPUT)	LOAD CAPACITANCE	$T_A = 25^\circ\text{C}$			SN54AHCT126 - 55°C to 125°C		SN74AHCT126 - 40°C to 85°C		SN74AHCT126 - 40°C to 125°C		UNIT
				MIN	TYP	MAX	MIN	MAX	MIN	MAX	MIN	MAX	
$t_{PLH}$	A	Y	$C_L = 15\text{ pF}$		3.8 <sup>(1)</sup>	5.5 <sup>(1)</sup>	1 <sup>(1)</sup>	6.5 <sup>(1)</sup>	1	6.5	1	7	ns
$t_{PHL}$				3.8 <sup>(1)</sup>	5.5 <sup>(1)</sup>	1 <sup>(1)</sup>	6.5 <sup>(1)</sup>	1	6.5	1	7		
$t_{PZH}$	OE	Y	$C_L = 15\text{ pF}$		3.6 <sup>(1)</sup>	5.1 <sup>(1)</sup>	1 <sup>(1)</sup>	6 <sup>(1)</sup>	1	6	1	6.5	ns
$t_{PZL}$				3.6 <sup>(1)</sup>	5.1 <sup>(1)</sup>	1 <sup>(1)</sup>	6 <sup>(1)</sup>	1	6	1	6.5		
$t_{PHZ}$	OE	Y	$C_L = 15\text{ pF}$		4.6 <sup>(1)</sup>	6.8 <sup>(1)</sup>	1 <sup>(1)</sup>	8 <sup>(1)</sup>	1	8	1	8.5	ns
$t_{PLZ}$				4.6 <sup>(1)</sup>	6.8 <sup>(1)</sup>	1 <sup>(1)</sup>	8 <sup>(1)</sup>	1	8	1	8.5		
$t_{PLH}$	A	Y	$C_L = 50\text{ pF}$		5.3	7.5	1	8.5	1	8.5	1	9.5	ns
$t_{PHL}$				5.3	7.5	1	8.5	1	8.5	1	9.5		
$t_{PZH}$	OE	Y	$C_L = 50\text{ pF}$		5.1	7.1	1	8	1	8	1	9	ns
$t_{PZL}$				5.1	7.1	1	8	1	8	1	9		
$t_{PHZ}$	OE	Y	$C_L = 50\text{ pF}$		6.1	8.8	1	10	1	10	1	11	ns
$t_{PLZ}$				6.1	8.8	1	10	1	10	1	11		
$t_{sk(o)}$			$C_L = 50\text{ pF}$			1 <sup>(2)</sup>			1		1	ns	

(1) On products compliant to MIL-PRF-38535, this parameter is not production tested.

(2) On products compliant to MIL-PRF-38535, this parameter does not apply.

## 5.7 Noise Characteristics

$V_{CC} = 5\text{ V}$ ,  $C_L = 50\text{ pF}$ ,  $T_A = 25^\circ\text{C}$ <sup>(1)</sup>

PARAMETER		SN74AHCT126		UNIT
		MIN	MAX	
$V_{OL(P)}$	Quiet output, maximum dynamic $V_{OL}$		0.8	V
$V_{OL(V)}$	Quiet output, minimum dynamic $V_{OL}$		- 0.8	V
$V_{OH(V)}$	Quiet output, minimum dynamic $V_{OH}$	4.4		V
$V_{IH(D)}$	High-level dynamic input voltage	2		V
$V_{IL(D)}$	Low-level dynamic input voltage		0.8	V

(1) Characteristics are for surface-mount packages only.

## 5.8 Operating Characteristics

$V_{CC} = 5\text{ V}$ ,  $T_A = 25^\circ\text{C}$

PARAMETER	TEST CONDITIONS	TYP	UNIT
$C_{pd}$	Power dissipation capacitance No load, $f = 1\text{ MHz}$	14	pF

## 5.9 Typical Characteristics



图 5-1. TPD vs Temperature

## 6 Parameter Measurement Information

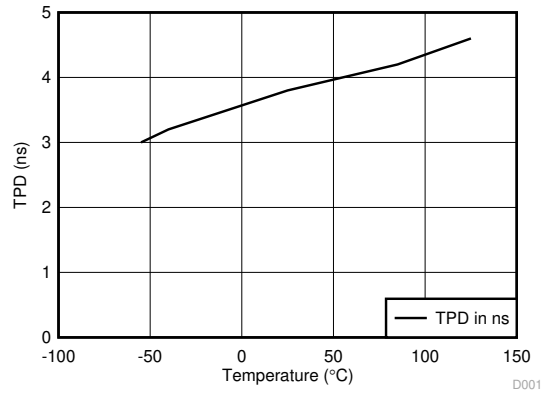
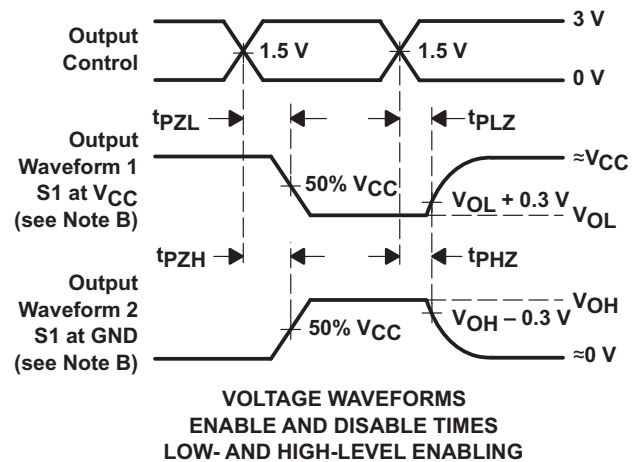
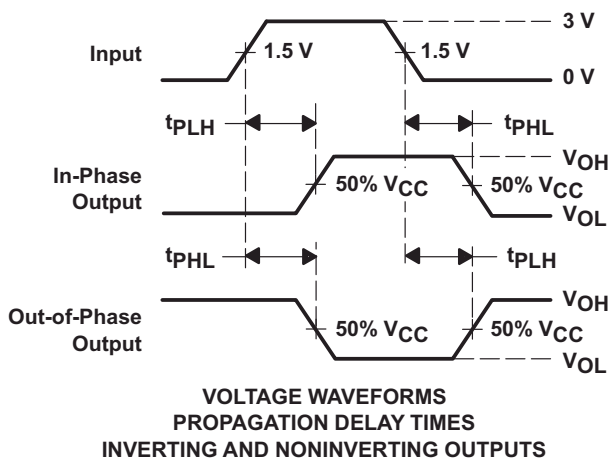
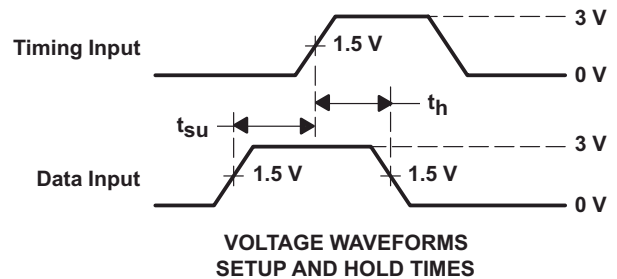
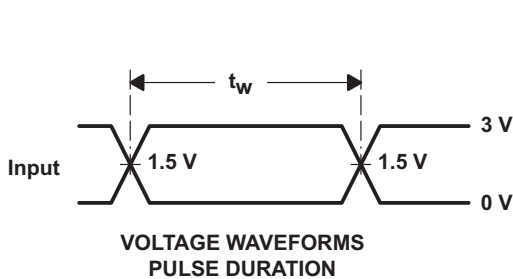
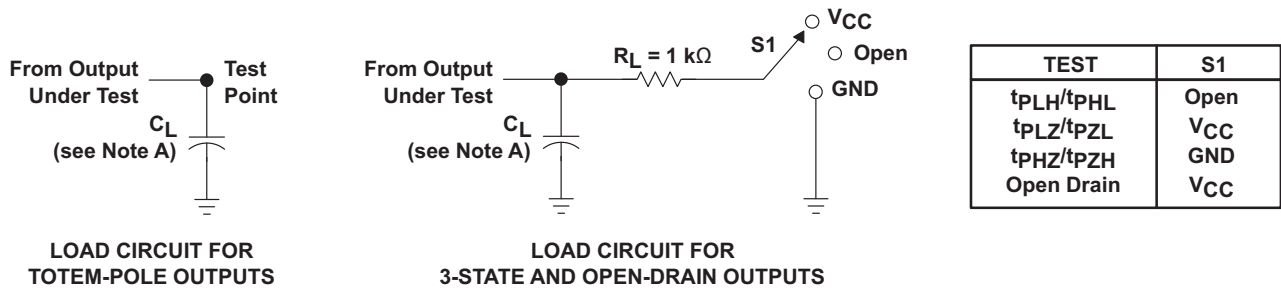

- NOTES: A.  $C_L$  includes probe and jig capacitance.  
 B. Waveform 1 is for an output with internal conditions such that the output is low except when disabled by the output control. Waveform 2 is for an output with internal conditions such that the output is high except when disabled by the output control.  
 C. All input pulses are supplied by generators having the following characteristics:  $PRR \leq 1\text{ MHz}$ ,  $Z_O = 50\ \Omega$ ,  $t_r \leq 3\text{ ns}$ ,  $t_f \leq 3\text{ ns}$ .  
 D. The outputs are measured one at a time with one input transition per measurement.  
 E. All parameters and waveforms are not applicable to all devices.

图 6-1. Load Circuit and Voltage and Waveforms

## 7 Detailed Description

### 7.1 Overview

The SNxAHCT126 devices are quadruple-bus buffer gates featuring independent line drivers with 3-state outputs.

Each output is disabled when the associated output-enable (OE) input is low. When OE is high, the respective gate passes the data from the A input to the Y output. For the high-impedance state during power up or power down, tie OE to GND through a pull-down resistor; the minimum value of the resistor is determined by the current-sourcing capability of the driver.

### 7.2 Functional Block Diagram

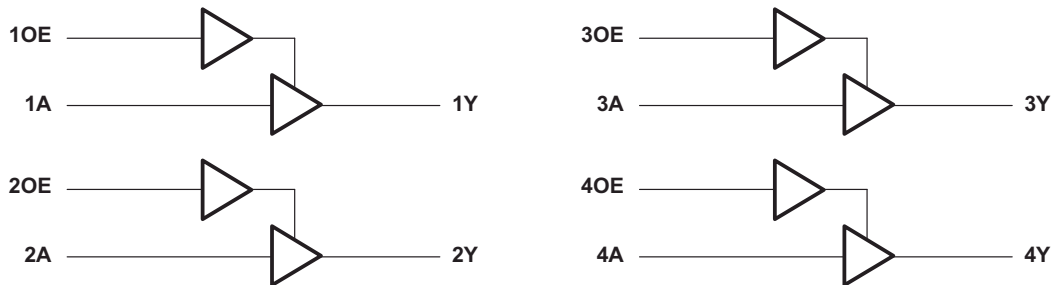

### 7.3 Feature Description

- TTL inputs
  - Lowered switching threshold allows up translation from 3.3 V to 5 V
- Slow edges reduce output ringing

### 7.4 Device Functional Modes

表 7-1. Function Table  
(Each Buffer)

INPUTS		OUTPUT Y
OE	A	
H	H	H
H	L	L
L	X	Z

## 8 Application and Implementation

### 备注

以下应用部分中的信息不属于 TI 器件规格的范围，TI 不担保其准确性和完整性。TI 的客户应负责确定器件是否适用于其应用。客户应验证并测试其设计，以确保系统功能。

### 8.1 Application Information

The SNx4AHCT126 is a low-drive CMOS device that can be used for a multitude of bus interface type applications where output ringing is a concern. The low drive and slow edge rates will minimize overshoot and undershoot on the outputs. The input switching levels have been lowered to accommodate TTL inputs of 0.8-V  $V_{IL}$  and 2-V  $V_{IH}$ . This feature makes it ideal for translating up from 3.3 V to 5 V. 图 8-2 shows this type of translation.

### 8.2 Typical Application



图 8-1. Typical Application Schematic

#### 8.2.1 Design Requirements

This device uses CMOS technology and has balanced output drive. Care should be taken to avoid bus contention because it can drive currents that would exceed maximum limits. The high drive will also create fast edges into light loads; therefore, routing and load conditions should be considered to prevent ringing.

#### 8.2.2 Detailed Design Procedure

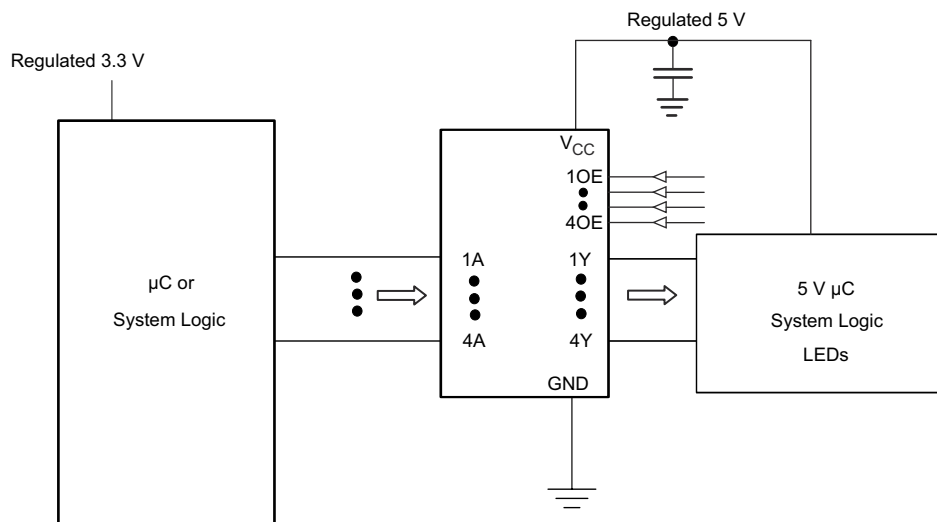
- Recommended input conditions:
  - Rise time and fall time specs: See ( $\Delta t / \Delta V$ ) in the [Recommended Operating Conditions](#) table.
  - Specified High and low levels: See ( $V_{IH}$  and  $V_{IL}$ ) in the [Recommended Operating Conditions](#) table.
  - Inputs are overvoltage tolerant allowing them to go as high as 5.5 V at any valid  $V_{CC}$
- Recommended output conditions:
  - Load currents should not exceed 25 mA per output and 50 mA total for the part
  - Outputs should not be pulled above  $V_{CC}$

### 8.2.3 Application Curves



图 8-2. Up Translation

### 8.3 Power Supply Recommendations

The power supply can be any voltage between the MIN and MAX supply voltage rating located in the [Recommended Operating Conditions](#) table.

Each  $V_{CC}$  pin should have a good bypass capacitor to prevent power disturbance. For devices with a single supply,  $0.1 \mu\text{F}$  is recommended. If there are multiple  $V_{CC}$  pins,  $0.01 \mu\text{F}$  or  $0.022 \mu\text{F}$  is recommended for each power pin. It is acceptable to parallel multiple bypass caps to reject different frequencies of noise. A  $0.1 \mu\text{F}$  and  $1 \mu\text{F}$  are commonly used in parallel. The bypass capacitor should be installed as close to the power pin as possible for best results.

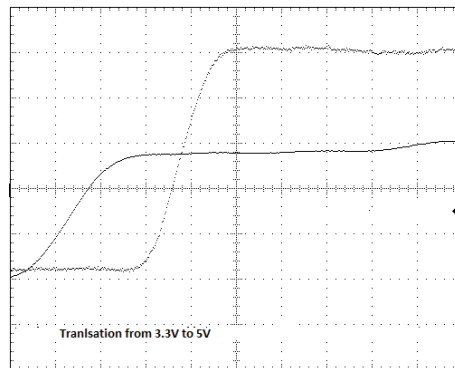
### 8.4 Layout

#### 8.4.1 Layout Guidelines

When using multiple bit logic devices inputs should not ever float.

In many cases, functions or parts of functions of digital logic devices are unused, for example, when only two inputs of a triple-input AND gate are used or only 3 of the 4 buffer gates are used. Such input pins should not be left unconnected because the undefined voltages at the outside connections result in undefined operational states. 图 8-3 shows the rules that must be observed under all circumstances. All unused inputs of digital logic devices must be connected to a high or low bias to prevent them from floating. The logic level that should be applied to any particular unused input depends on the function of the device. Generally they will be tied to GND or  $V_{CC}$ ; whichever makes more sense or is more convenient. It is generally acceptable to float outputs unless the part is a transceiver. If the transceiver has an output enable pin, it will disable the outputs section of the part when asserted. This will not disable the input section of the IO's so they cannot float when disabled.

#### 8.4.2 Layout Example



图 8-3. Layout Diagram

## 9 Device and Documentation Support

### 9.1 接收文档更新通知

要接收文档更新通知，请导航至 [ti.com](https://www.ti.com) 上的器件产品文件夹。点击 [订阅更新](#) 进行注册，即可每周接收产品信息更改摘要。有关更改的详细信息，请查看任何已修订文档中包含的修订历史记录。

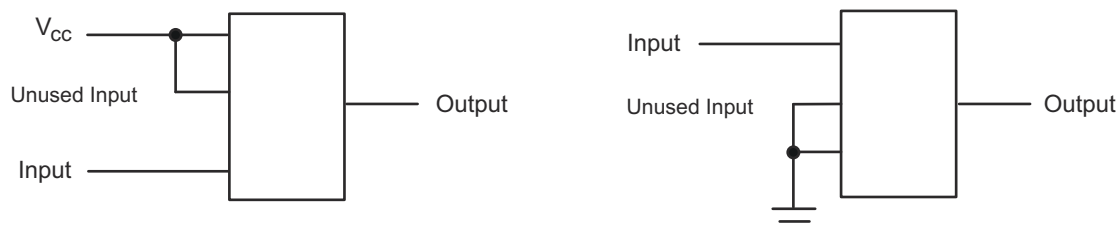
### 9.2 支持资源

[TI E2E™ 中文支持论坛](#) 是工程师的重要参考资料，可直接从专家处获得快速、经过验证的解答和设计帮助。搜索现有解答或提出自己的问题，获得所需的快速设计帮助。

链接的内容由各个贡献者“按原样”提供。这些内容并不构成 TI 技术规范，并且不一定反映 TI 的观点；请参阅 TI 的 [使用条款](#)。

### 9.3 Trademarks

TI E2E™ is a trademark of Texas Instruments.

所有商标均为其各自所有者的财产。

### 9.4 静电放电警告



静电放电 (ESD) 会损坏这个集成电路。德州仪器 (TI) 建议通过适当的预防措施处理所有集成电路。如果不遵守正确的处理和安装程序，可能会损坏集成电路。

ESD 的损坏小至导致微小的性能降级，大至整个器件故障。精密的集成电路可能更容易受到损坏，这是因为非常细微的参数更改都可能会导致器件与其发布的规格不相符。

### 9.5 术语表

[TI 术语表](#) 本术语表列出并解释了术语、首字母缩略词和定义。

## 10 Revision History

注：以前版本的页码可能与当前版本的页码不同

Changes from Revision R (October 2023) to Revision S (February 2024)	Page
<ul style="list-style-type: none"> <li>Updated thermal values for NS package from <math>R^{\theta}_{JA} = 90.7</math> to <math>120.9</math>, <math>R^{\theta}_{JC(top)} = 48.3</math> to <math>78.2</math>, <math>R^{\theta}_{JB} = 49.4</math> to <math>81.6</math>, <math>\Psi_{JT} = 14.6</math> to <math>42.8</math>, <math>\Psi_{JB} = 49.1</math> to <math>81.1</math>, <math>R^{\theta}_{JC(bot)} = N/A</math>, all values in <math>^{\circ}C/W</math> .....</li> </ul>	6
Changes from Revision Q (May 2023) to Revision R (October 2023)	Page
<ul style="list-style-type: none"> <li>Updated <math>R^{\theta}_{JA}</math> values: <math>D = 90.6</math> to <math>124.5</math>, <math>PW = 122.6</math> to <math>147.7</math>; Updated D and PW packages for <math>R^{\theta}_{JC(top)}</math>, <math>R^{\theta}_{JB}</math>, <math>\Psi_{JT}</math>, <math>\Psi_{JB}</math>, and <math>R^{\theta}_{JC(bot)}</math>, all values in <math>^{\circ}C/W</math> .....</li> </ul>	6

## 11 Mechanical, Packaging, and Orderable Information

The following pages include mechanical, packaging, and orderable information. This information is the most current data available for the designated devices. This data is subject to change without notice and revision of this document. For browser-based versions of this data sheet, refer to the left-hand navigation.

**PACKAGING INFORMATION**

Orderable part number	Status (1)	Material type (2)	Package   Pins	Package qty   Carrier	RoHS (3)	Lead finish/ Ball material (4)	MSL rating/ Peak reflow (5)	Op temp (°C)	Part marking (6)
<a href="#">5962-9686301QDA</a>	NRND	Production	CFP (W)   14	25   TUBE	No	SNPB	N/A for Pkg Type	-55 to 125	5962-9686301QD A SNJ54AHCT126W
<a href="#">SN74AHCT126BQAR</a>	Active	Production	WQFN (BQA)   14	3000   LARGE T&R	Yes	SN	Level-1-260C-UNLIM	-40 to 125	AHT126
SN74AHCT126BQAR.A	Active	Production	WQFN (BQA)   14	3000   LARGE T&R	Yes	SN	Level-1-260C-UNLIM	-40 to 125	AHT126
<a href="#">SN74AHCT126D</a>	Obsolete	Production	SOIC (D)   14	-	-	Call TI	Call TI	-40 to 85	AHCT126
<a href="#">SN74AHCT126DBR</a>	Active	Production	SSOP (DB)   14	2000   LARGE T&R	Yes	NIPDAU	Level-1-260C-UNLIM	-40 to 125	HB126
SN74AHCT126DBR.A	Active	Production	SSOP (DB)   14	2000   LARGE T&R	Yes	NIPDAU	Level-1-260C-UNLIM	-40 to 125	HB126
<a href="#">SN74AHCT126DGVR</a>	Active	Production	TVSOP (DGV)   14	2000   LARGE T&R	Yes	NIPDAU	Level-1-260C-UNLIM	-40 to 125	HB126
SN74AHCT126DGVR.A	Active	Production	TVSOP (DGV)   14	2000   LARGE T&R	Yes	NIPDAU	Level-1-260C-UNLIM	-40 to 125	HB126
<a href="#">SN74AHCT126DR</a>	Active	Production	SOIC (D)   14	2500   LARGE T&R	Yes	NIPDAU	Level-1-260C-UNLIM	-40 to 125	AHCT126
SN74AHCT126DR.A	Active	Production	SOIC (D)   14	2500   LARGE T&R	Yes	NIPDAU	Level-1-260C-UNLIM	-40 to 125	AHCT126
<a href="#">SN74AHCT126N</a>	Active	Production	PDIP (N)   14	25   TUBE	Yes	NIPDAU	N/A for Pkg Type	-40 to 125	SN74AHCT126N
SN74AHCT126N.A	Active	Production	PDIP (N)   14	25   TUBE	Yes	NIPDAU	N/A for Pkg Type	-40 to 125	SN74AHCT126N
<a href="#">SN74AHCT126NSR</a>	Active	Production	SOP (NS)   14	2000   LARGE T&R	Yes	NIPDAU	Level-1-260C-UNLIM	-40 to 125	AHCT126
SN74AHCT126NSR.A	Active	Production	SOP (NS)   14	2000   LARGE T&R	Yes	NIPDAU	Level-1-260C-UNLIM	-40 to 125	AHCT126
<a href="#">SN74AHCT126PW</a>	Obsolete	Production	TSSOP (PW)   14	-	-	Call TI	Call TI	-40 to 125	HB126
<a href="#">SN74AHCT126PWR</a>	Active	Production	TSSOP (PW)   14	2000   LARGE T&R	Yes	NIPDAU   SN	Level-1-260C-UNLIM	-40 to 125	HB126
SN74AHCT126PWR.A	Active	Production	TSSOP (PW)   14	2000   LARGE T&R	Yes	NIPDAU	Level-1-260C-UNLIM	-40 to 125	HB126
<a href="#">SNJ54AHCT126W</a>	NRND	Production	CFP (W)   14	25   TUBE	No	SNPB	N/A for Pkg Type	-55 to 125	5962-9686301QD A SNJ54AHCT126W
SNJ54AHCT126W.A	NRND	Production	CFP (W)   14	25   TUBE	No	SNPB	N/A for Pkg Type	-55 to 125	5962-9686301QD A SNJ54AHCT126W

(1) **Status:** For more details on status, see our [product life cycle](#).

(2) **Material type:** When designated, preproduction parts are prototypes/experimental devices, and are not yet approved or released for full production. Testing and final process, including without limitation quality assurance, reliability performance testing, and/or process qualification, may not yet be complete, and this item is subject to further changes or possible discontinuation. If available for ordering, purchases will be subject to an additional waiver at checkout, and are intended for early internal evaluation purposes only. These items are sold without warranties of any kind.

(3) **RoHS values:** Yes, No, RoHS Exempt. See the [TI RoHS Statement](#) for additional information and value definition.

(4) **Lead finish/Ball material:** Parts may have multiple material finish options. Finish options are separated by a vertical ruled line. Lead finish/Ball material values may wrap to two lines if the finish value exceeds the maximum column width.

(5) **MSL rating/Peak reflow:** The moisture sensitivity level ratings and peak solder (reflow) temperatures. In the event that a part has multiple moisture sensitivity ratings, only the lowest level per JEDEC standards is shown. Refer to the shipping label for the actual reflow temperature that will be used to mount the part to the printed circuit board.

(6) **Part marking:** There may be an additional marking, which relates to the logo, the lot trace code information, or the environmental category of the part.

Multiple part markings will be inside parentheses. Only one part marking contained in parentheses and separated by a "~" will appear on a part. If a line is indented then it is a continuation of the previous line and the two combined represent the entire part marking for that device.

**Important Information and Disclaimer:** The information provided on this page represents TI's knowledge and belief as of the date that it is provided. TI bases its knowledge and belief on information provided by third parties, and makes no representation or warranty as to the accuracy of such information. Efforts are underway to better integrate information from third parties. TI has taken and continues to take reasonable steps to provide representative and accurate information but may not have conducted destructive testing or chemical analysis on incoming materials and chemicals. TI and TI suppliers consider certain information to be proprietary, and thus CAS numbers and other limited information may not be available for release.

In no event shall TI's liability arising out of such information exceed the total purchase price of the TI part(s) at issue in this document sold by TI to Customer on an annual basis.

**OTHER QUALIFIED VERSIONS OF SN54AHCT126, SN74AHCT126 :**

- Catalog : [SN74AHCT126](#)
- Automotive : [SN74AHCT126-Q1](#), [SN74AHCT126-Q1](#)
- Enhanced Product : [SN74AHCT126-EP](#), [SN74AHCT126-EP](#)
- Military : [SN54AHCT126](#)

NOTE: Qualified Version Definitions:

- Catalog - TI's standard catalog product
- Automotive - Q100 devices qualified for high-reliability automotive applications targeting zero defects
- Enhanced Product - Supports Defense, Aerospace and Medical Applications

- Military - QML certified for Military and Defense Applications

**TAPE AND REEL INFORMATION**

**QUADRANT ASSIGNMENTS FOR PIN 1 ORIENTATION IN TAPE**

\*All dimensions are nominal

Device	Package Type	Package Drawing	Pins	SPQ	Reel Diameter (mm)	Reel Width W1 (mm)	A0 (mm)	B0 (mm)	K0 (mm)	P1 (mm)	W (mm)	Pin1 Quadrant
SN74AHCT126BQAR	WQFN	BQA	14	3000	180.0	12.4	2.8	3.3	1.1	4.0	12.0	Q1
SN74AHCT126DBR	SSOP	DB	14	2000	330.0	16.4	8.35	6.6	2.4	12.0	16.0	Q1
SN74AHCT126DGVR	TVSOP	DGV	14	2000	330.0	12.4	6.8	4.0	1.6	8.0	12.0	Q1
SN74AHCT126DR	SOIC	D	14	2500	330.0	16.4	6.5	9.0	2.1	8.0	16.0	Q1
SN74AHCT126NSR	SOP	NS	14	2000	330.0	16.4	8.45	10.55	2.5	12.0	16.2	Q1
SN74AHCT126NSR	SOP	NS	14	2000	330.0	16.4	8.1	10.4	2.5	12.0	16.0	Q1
SN74AHCT126PWR	TSSOP	PW	14	2000	330.0	12.4	6.9	5.6	1.6	8.0	12.0	Q1

**TAPE AND REEL BOX DIMENSIONS**

\*All dimensions are nominal

Device	Package Type	Package Drawing	Pins	SPQ	Length (mm)	Width (mm)	Height (mm)
SN74AHCT126BQAR	WQFN	BQA	14	3000	210.0	185.0	35.0
SN74AHCT126DBR	SSOP	DB	14	2000	353.0	353.0	32.0
SN74AHCT126DGVR	TVSOP	DGV	14	2000	353.0	353.0	32.0
SN74AHCT126DR	SOIC	D	14	2500	353.0	353.0	32.0
SN74AHCT126NSR	SOP	NS	14	2000	353.0	353.0	32.0
SN74AHCT126NSR	SOP	NS	14	2000	353.0	353.0	32.0
SN74AHCT126PWR	TSSOP	PW	14	2000	353.0	353.0	32.0

**TUBE**

\*All dimensions are nominal

Device	Package Name	Package Type	Pins	SPQ	L (mm)	W (mm)	T (μm)	B (mm)
5962-9686301QDA	W	CFP	14	25	506.98	26.16	6220	NA
SN74AHCT126N	N	PDIP	14	25	506	13.97	11230	4.32
SN74AHCT126N	N	PDIP	14	25	506	13.97	11230	4.32
SN74AHCT126N.A	N	PDIP	14	25	506	13.97	11230	4.32
SN74AHCT126N.A	N	PDIP	14	25	506	13.97	11230	4.32
SNJ54AHCT126W	W	CFP	14	25	506.98	26.16	6220	NA
SNJ54AHCT126W.A	W	CFP	14	25	506.98	26.16	6220	NA

W (R-GDFP-F14)

CERAMIC DUAL FLATPACK

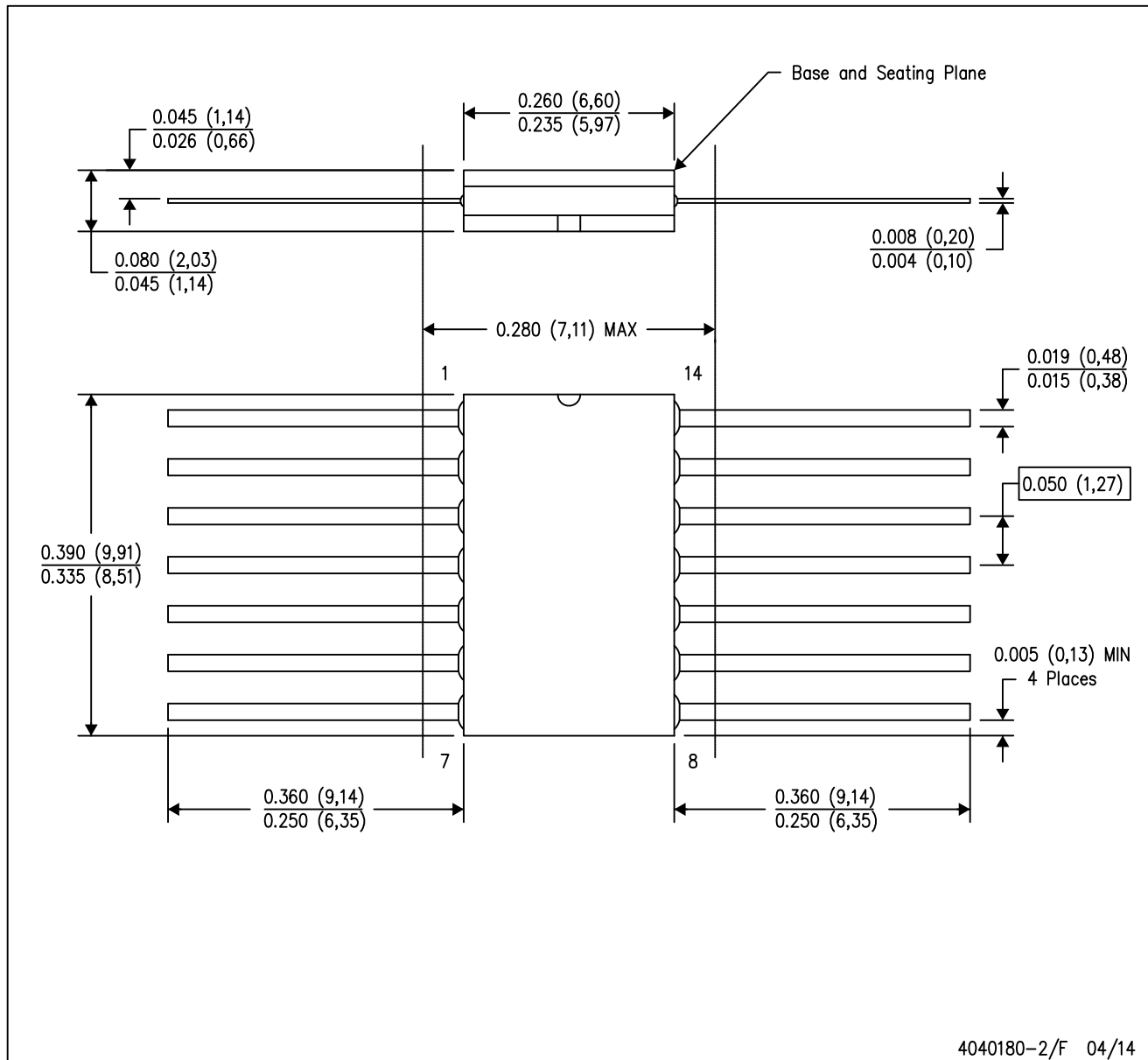

- NOTES:
- All linear dimensions are in inches (millimeters).
  - This drawing is subject to change without notice.
  - This package can be hermetically sealed with a ceramic lid using glass frit.
  - Index point is provided on cap for terminal identification only.
  - Falls within MIL STD 1835 GDFP1-F14

# DB0014A



# PACKAGE OUTLINE

## SSOP - 2 mm max height

SMALL OUTLINE PACKAGE

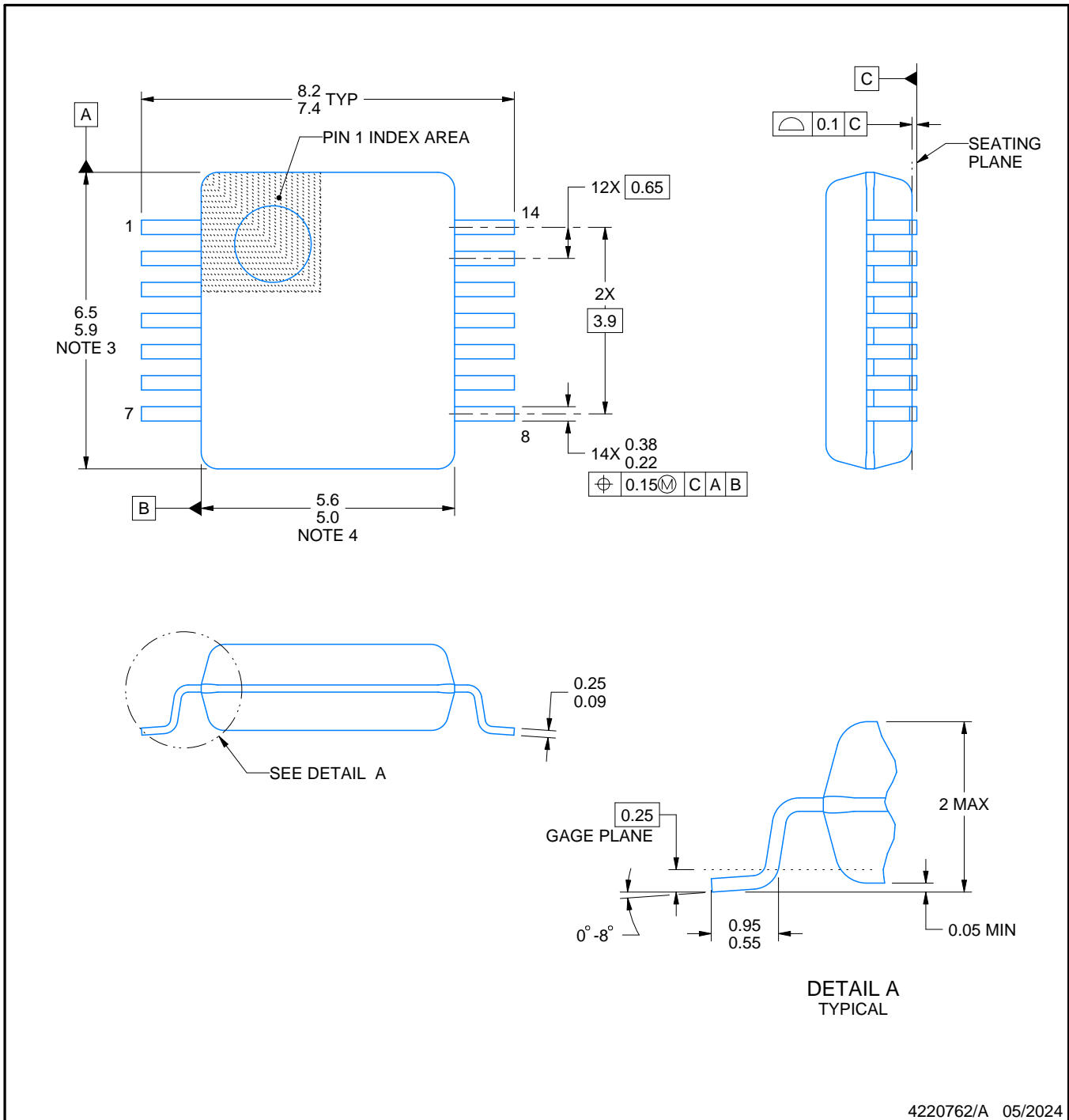

### NOTES:

1. All linear dimensions are in millimeters. Any dimensions in parenthesis are for reference only. Dimensioning and tolerancing per ASME Y14.5M.
2. This drawing is subject to change without notice.
3. This dimension does not include mold flash, protrusions, or gate burrs. Mold flash, protrusions, or gate burrs shall not exceed 0.15 mm per side.
4. Reference JEDEC registration MO-150.

# EXAMPLE BOARD LAYOUT

DB0014A

SSOP - 2 mm max height

SMALL OUTLINE PACKAGE

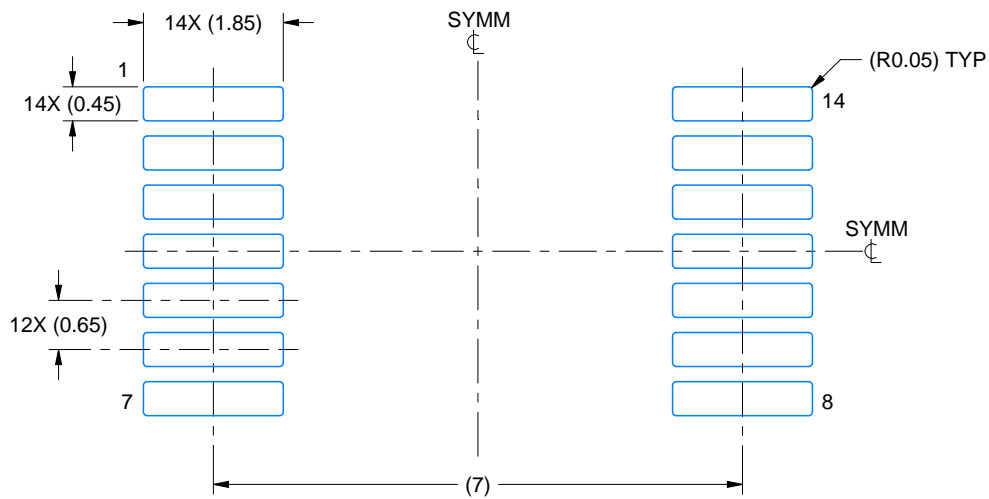

LAND PATTERN EXAMPLE  
EXPOSED METAL SHOWN  
SCALE: 10X

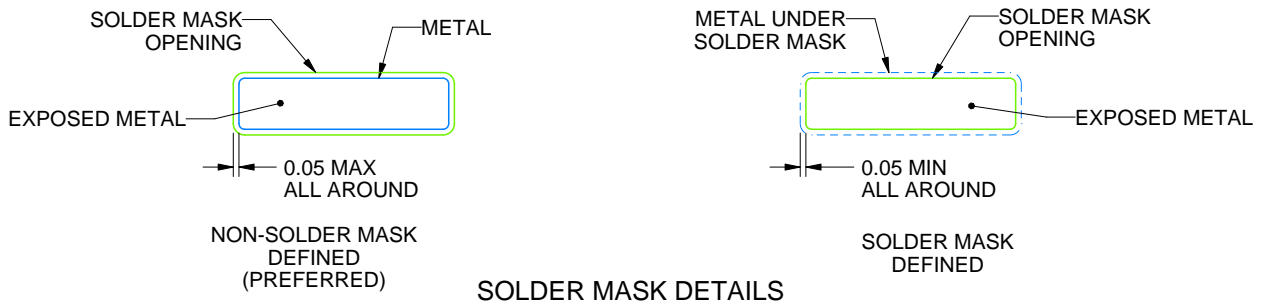

4220762/A 05/2024

NOTES: (continued)

5. Publication IPC-7351 may have alternate designs.
6. Solder mask tolerances between and around signal pads can vary based on board fabrication site.

# EXAMPLE STENCIL DESIGN

DB0014A

SSOP - 2 mm max height

SMALL OUTLINE PACKAGE

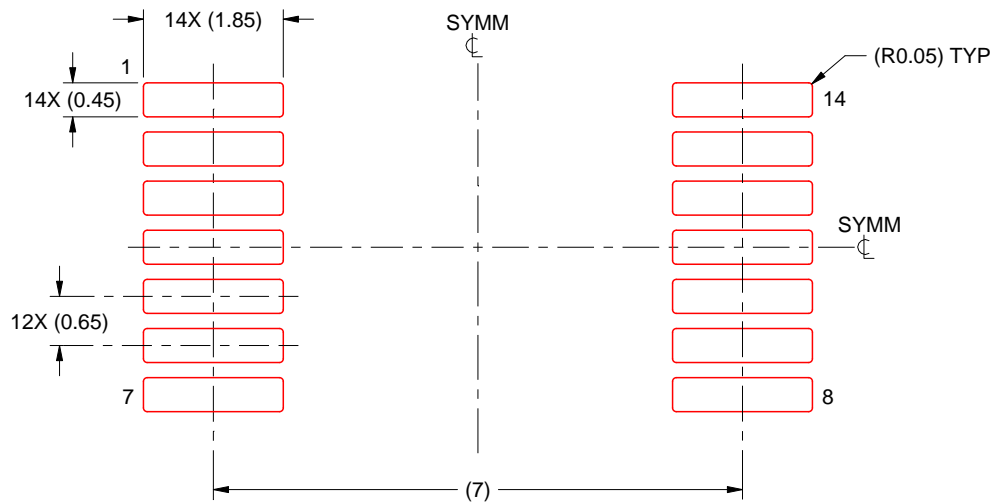

SOLDER PASTE EXAMPLE  
BASED ON 0.125 mm THICK STENCIL  
SCALE: 10X

4220762/A 05/2024

NOTES: (continued)

7. Laser cutting apertures with trapezoidal walls and rounded corners may offer better paste release. IPC-7525 may have alternate design recommendations.
8. Board assembly site may have different recommendations for stencil design.

N (R-PDIP-T\*\*)

PLASTIC DUAL-IN-LINE PACKAGE

16 PINS SHOWN



- NOTES:
- A. All linear dimensions are in inches (millimeters).
  - B. This drawing is subject to change without notice.
  - Falls within JEDEC MS-001, except 18 and 20 pin minimum body length (Dim A).
  - The 20 pin end lead shoulder width is a vendor option, either half or full width.

PW0014A



**PACKAGE OUTLINE**  
**TSSOP - 1.2 mm max height**

SMALL OUTLINE PACKAGE



4220202/B 12/2023

NOTES:

1. All linear dimensions are in millimeters. Any dimensions in parenthesis are for reference only. Dimensioning and tolerancing per ASME Y14.5M.
2. This drawing is subject to change without notice.
3. This dimension does not include mold flash, protrusions, or gate burrs. Mold flash, protrusions, or gate burrs shall not exceed 0.15 mm per side.
4. This dimension does not include interlead flash. Interlead flash shall not exceed 0.25 mm per side.
5. Reference JEDEC registration MO-153.

# EXAMPLE BOARD LAYOUT

PW0014A

TSSOP - 1.2 mm max height

SMALL OUTLINE PACKAGE



LAND PATTERN EXAMPLE  
EXPOSED METAL SHOWN  
SCALE: 10X



4220202/B 12/2023

NOTES: (continued)

- 6. Publication IPC-7351 may have alternate designs.
- 7. Solder mask tolerances between and around signal pads can vary based on board fabrication site.

# EXAMPLE STENCIL DESIGN

PW0014A

TSSOP - 1.2 mm max height

SMALL OUTLINE PACKAGE



SOLDER PASTE EXAMPLE  
BASED ON 0.125 mm THICK STENCIL  
SCALE: 10X

4220202/B 12/2023

NOTES: (continued)

- 8. Laser cutting apertures with trapezoidal walls and rounded corners may offer better paste release. IPC-7525 may have alternate design recommendations.
- 9. Board assembly site may have different recommendations for stencil design.



# D0014A

# PACKAGE OUTLINE

## SOIC - 1.75 mm max height

SMALL OUTLINE INTEGRATED CIRCUIT



4220718/A 09/2016

### NOTES:

1. All linear dimensions are in millimeters. Dimensions in parenthesis are for reference only. Dimensioning and tolerancing per ASME Y14.5M.
2. This drawing is subject to change without notice.
3. This dimension does not include mold flash, protrusions, or gate burrs. Mold flash, protrusions, or gate burrs shall not exceed 0.15 mm, per side.
4. This dimension does not include interlead flash. Interlead flash shall not exceed 0.43 mm, per side.
5. Reference JEDEC registration MS-012, variation AB.

# EXAMPLE BOARD LAYOUT

D0014A

SOIC - 1.75 mm max height

SMALL OUTLINE INTEGRATED CIRCUIT



LAND PATTERN EXAMPLE  
SCALE:8X



SOLDER MASK DETAILS

4220718/A 09/2016

NOTES: (continued)

- 6. Publication IPC-7351 may have alternate designs.
- 7. Solder mask tolerances between and around signal pads can vary based on board fabrication site.

# EXAMPLE STENCIL DESIGN

D0014A

SOIC - 1.75 mm max height

SMALL OUTLINE INTEGRATED CIRCUIT



SOLDER PASTE EXAMPLE  
BASED ON 0.125 mm THICK STENCIL  
SCALE:8X

4220718/A 09/2016

NOTES: (continued)

8. Laser cutting apertures with trapezoidal walls and rounded corners may offer better paste release. IPC-7525 may have alternate design recommendations.
9. Board assembly site may have different recommendations for stencil design.

## GENERIC PACKAGE VIEW

**BQA 14**

**WQFN - 0.8 mm max height**

2.5 x 3, 0.5 mm pitch

PLASTIC QUAD FLATPACK - NO LEAD

This image is a representation of the package family, actual package may vary.  
Refer to the product data sheet for package details.

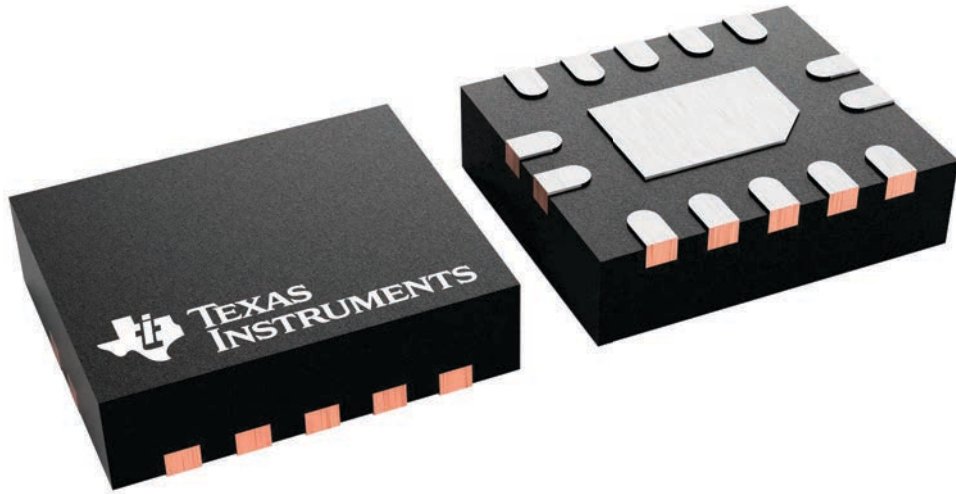

4227145/A

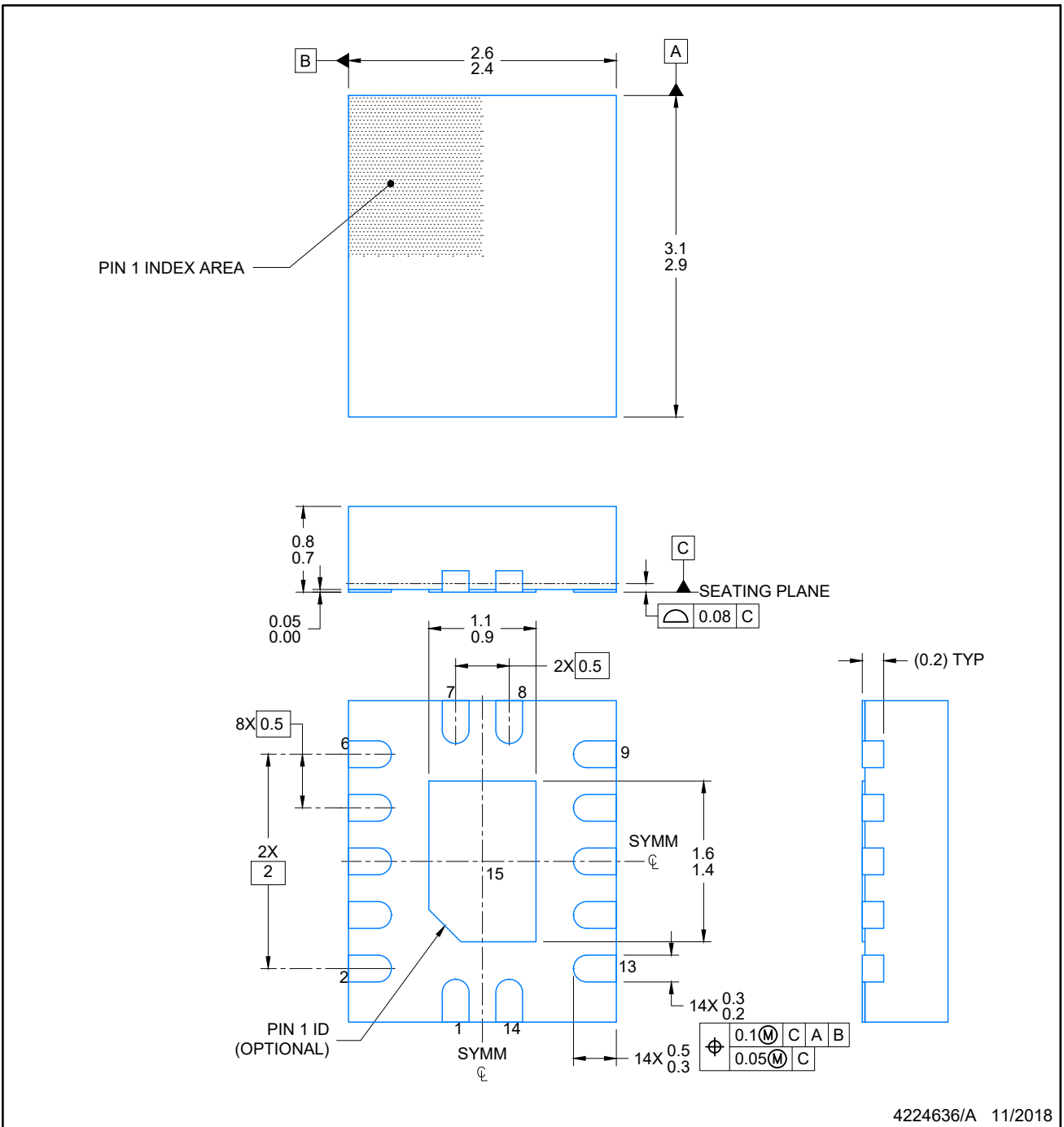

NOTES:

1. All linear dimensions are in millimeters. Any dimensions in parenthesis are for reference only. Dimensioning and tolerancing per ASME Y14.5M.
2. This drawing is subject to change without notice.
3. The package thermal pad must be soldered to the printed circuit board for optimal thermal and mechanical performance.

# EXAMPLE BOARD LAYOUT

WQFN - 0.8 mm max height

BQA0014A

PLASTIC QUAD FLAT PACK-NO LEAD



LAND PATTERN EXAMPLE  
EXPOSED METAL SHOWN  
SCALE: 20X

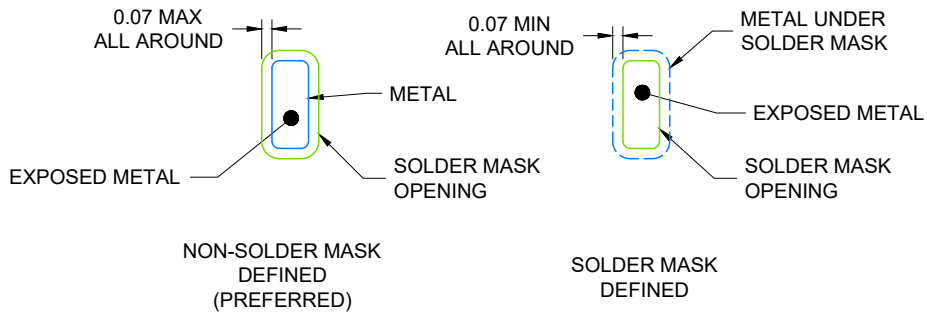

4224636/A 11/2018

NOTES: (continued)

4. This package is designed to be soldered to a thermal pad on the board. For more information, see Texas Instruments literature number SLUA271 ([www.ti.com/lit/sluea271](http://www.ti.com/lit/sluea271)).
5. Vias are optional depending on application, refer to device data sheet. If any vias are implemented, refer to their locations shown on this view. It is recommended that vias under paste be filled, plugged or tented.

**EXAMPLE STENCIL DESIGN**

**BQA0014A**

**WQFN - 0.8 mm max height**

PLASTIC QUAD FLAT PACK-NO LEAD

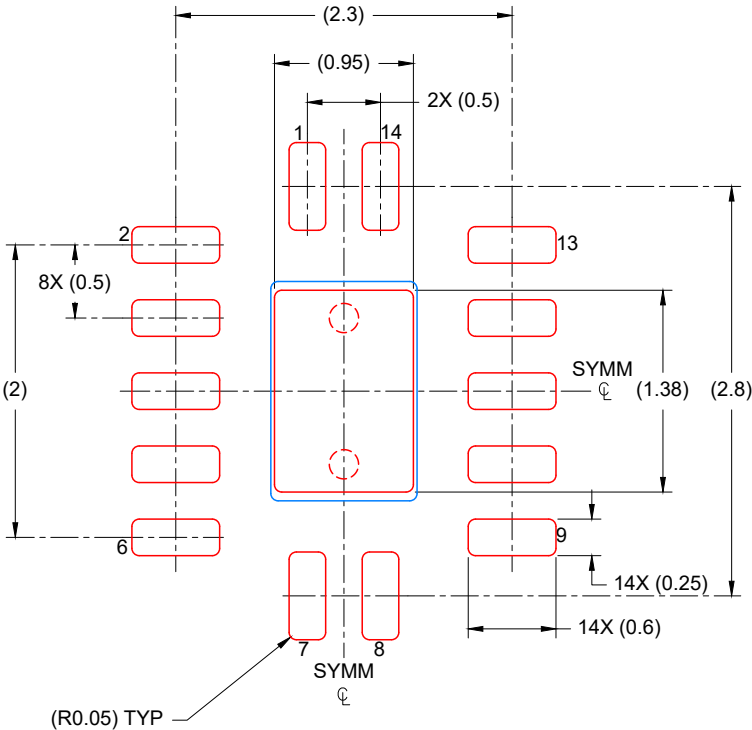

**SOLDER PASTE EXAMPLE**  
 BASED ON 0.125 mm THICK STENCIL

EXPOSED PAD  
 88% PRINTED COVERAGE BY AREA  
 SCALE: 20X

4224636/A 11/2018

NOTES: (continued)

- 6. Laser cutting apertures with trapezoidal walls and rounded corners may offer better paste release. IPC-7525 may have alternate design recommendations.



## 重要通知和免责声明

TI“按原样”提供技术和可靠性数据（包括数据表）、设计资源（包括参考设计）、应用或其他设计建议、网络工具、安全信息和其他资源，不保证没有瑕疵且不做任何明示或暗示的担保，包括但不限于对适销性、与某特定用途的适用性或不侵犯任何第三方知识产权的暗示担保。

这些资源可供使用 TI 产品进行设计的熟练开发人员使用。您将自行承担以下全部责任：(1) 针对您的应用选择合适的 TI 产品，(2) 设计、验证并测试您的应用，(3) 确保您的应用满足相应标准以及任何其他安全、安保法规或其他要求。

这些资源如有变更，恕不另行通知。TI 授权您仅可将这些资源用于研发本资源所述的 TI 产品的相关应用。严禁以其他方式对这些资源进行复制或展示。您无权使用任何其他 TI 知识产权或任何第三方知识产权。对于因您对这些资源的使用而对 TI 及其代表造成的任何索赔、损害、成本、损失和债务，您将全额赔偿，TI 对此概不负责。

TI 提供的产品受 [TI 销售条款](#)、[TI 通用质量指南](#) 或 [ti.com](#) 上其他适用条款或 TI 产品随附的其他适用条款的约束。TI 提供这些资源并不会扩展或以其他方式更改 TI 针对 TI 产品发布的适用的担保或担保免责声明。除非德州仪器 (TI) 明确将某产品指定为定制产品或客户特定产品，否则其产品均为按确定价格收入目录的标准通用器件。

TI 反对并拒绝您可能提出的任何其他或不同的条款。

版权所有 © 2026，德州仪器 (TI) 公司

最后更新日期：2025 年 10 月