

## SNx4AHC08 四路双输入正与门

### 1 特性

- 2V 至 5.5V 的工作范围
- 闩锁性能超过 250mA，符合 JESD 17 规范
- ESD 保护性能超过 JESD 22 规范要求

### 2 应用

- 服务器
- 网络交换机
- PC 和笔记本电脑
- 电子销售终端

### 3 说明

SNx4AHC08 器件是四路双输入正与门。此类器件以正逻辑执行布尔函数  $Y = A \cdot B$  或  $Y = \overline{A + B}$ 。

#### 器件信息

器件型号	封装 <sup>(1)</sup>	封装尺寸 <sup>(2)</sup>
SN74AHC08	D ( SOIC , 14 )	8.65mm × 3.90mm
	DB ( SSOP , 14 )	6.20mm × 5.30mm
	DGV ( TVSOP , 14 )	3.60mm × 4.40mm
	N ( PDIP , 14 )	19.30mm × 6.35mm
	NS ( SO , 14 )	10.30mm × 5.30mm
	PW ( TSSOP , 14 )	5.00mm × 4.40mm
	RGY ( VQFN , 14 )	3.50mm × 3.50mm
	BQA ( WQFN , 14 )	3mm × 2.5mm
SN54AHC08	FK ( LCCC , 20 )	8.89mm × 8.89mm

(1) 更多相关信息，请参阅第 11 节。

(2) 封装尺寸 (长 × 宽) 为标称值，不包括引脚。

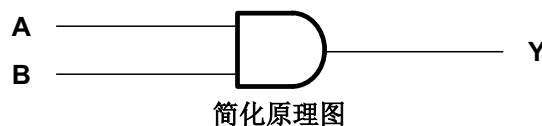

## Table of Contents

<b>1 特性</b> .....	<b>1</b>	7.1 Overview.....	<b>12</b>
<b>2 应用</b> .....	<b>1</b>	7.2 Functional Block Diagram.....	<b>12</b>
<b>3 说明</b> .....	<b>1</b>	7.3 Feature Description.....	<b>12</b>
<b>4 Pin Configuration and Functions</b> .....	<b>3</b>	7.4 Device Functional Modes.....	<b>12</b>
<b>5 Specifications</b> .....	<b>5</b>	<b>8 Application and Implementation</b> .....	<b>13</b>
5.1 Absolute Maximum Ratings.....	<b>5</b>	8.1 Application Information.....	<b>13</b>
5.2 ESD Ratings.....	<b>5</b>	8.2 Typical Application.....	<b>13</b>
5.3 Recommended Operating Conditions.....	<b>5</b>	8.3 Layout.....	<b>15</b>
5.4 Thermal Information.....	<b>6</b>	<b>9 Device and Documentation Support</b> .....	<b>16</b>
5.5 Electrical Characteristics, $T_A = 25^\circ\text{C}$ .....	<b>6</b>	9.1 Documentation Support.....	<b>16</b>
5.6 Electrical Characteristics, $T_A = -55^\circ\text{C}$ to $125^\circ\text{C}$ .....	<b>7</b>	9.2 接收文档更新通知.....	<b>16</b>
5.7 Electrical Characteristics, $T_A = -40^\circ\text{C}$ to $125^\circ\text{C}$ .....	<b>7</b>	9.3 支持资源.....	<b>16</b>
5.8 Switching Characteristics, $V_{CC} = 3.3\text{ V} \pm 0.3\text{ V}$ .....	<b>8</b>	9.4 Trademarks.....	<b>16</b>
5.9 Switching Characteristics, $V_{CC} = 5\text{ V} \pm 0.5\text{ V}$ .....	<b>8</b>	9.5 静电放电警告.....	<b>16</b>
5.10 Noise Characteristics.....	<b>9</b>	9.6 术语表.....	<b>16</b>
5.11 Operating Characteristics.....	<b>9</b>	<b>10 Revision History</b> .....	<b>16</b>
5.12 Typical Characteristics.....	<b>10</b>	<b>11 Mechanical, Packaging, and Orderable Information</b> .....	<b>17</b>
<b>6 Parameter Measurement Information</b> .....	<b>11</b>		
<b>7 Detailed Description</b> .....	<b>12</b>		

### 4 Pin Configuration and Functions



图 4-1. D, DB, DGV, N, NS, PW, or W Package 14-Pin SOIC, SSOP, TVSOP, PDIP, SO, or TSSOP (Top View)

图 4-2. FK Package 20-Pin LCCC (Top View)

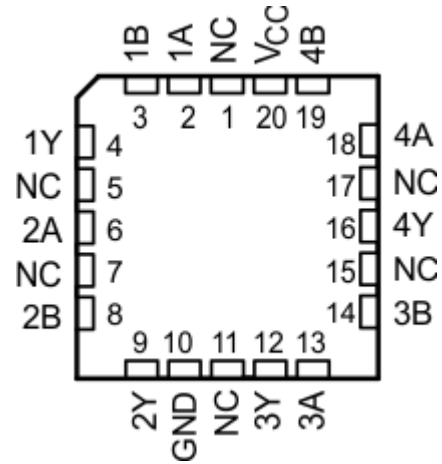
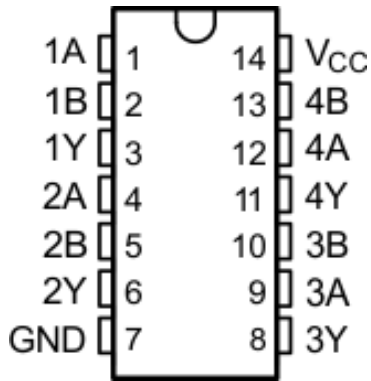

图 4-3. RGY or BQA Package 14-Pin VQFN or WQFN (Top View)

表 4-1. Pin Functions

NAME	PIN			I/O	DESCRIPTION
	SOIC, SSOP, TVSOP, PDIP, SO, TSSOP	VQFN, WQFN	LCSS		
1A	1	1	2	I	1A Input
1B	2	2	3	I	1B Input
1Y	3	3	4	O	1Y Output
2A	4	4	6	I	2A Input
2B	5	5	8	I	2B Input
2Y	6	6	9	O	2Y Output
3Y	8	8	12	O	3Y Output
3A	9	9	13	I	3A Input
3B	10	10	14	I	3B Input
4Y	11	11	16	O	4Y Output
4A	12	12	18	I	4A Input
4B	13	13	19	I	4B Input
GND	7	7	10	—	Ground Pin
NC	—	—	1, 5, 7, 11, 15, 17	—	No Connection
V <sub>CC</sub>	14	14	20	—	Power Pin

## 5 Specifications

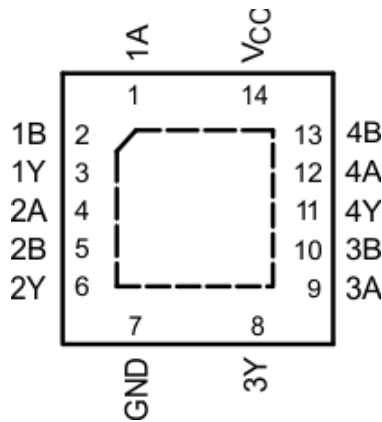
### 5.1 Absolute Maximum Ratings

over operating free-air temperature range (unless otherwise noted)<sup>(1)</sup>

		MIN	MAX	UNIT
V <sub>CC</sub>	Supply voltage	- 0.5	7	V
V <sub>I</sub>	Input voltage <sup>(2)</sup>	- 0.5	7	V
V <sub>O</sub>	Output voltage, V <sub>O</sub> <sup>(2)</sup>	- 0.5	V <sub>CC</sub> + 0.5	V
I <sub>IK</sub>	Input clamp current	V <sub>I</sub> < 0	-20	mA
I <sub>OK</sub>	Output clamp current	V <sub>O</sub> < 0 or V <sub>O</sub> > V <sub>CC</sub>	±20	mA
I <sub>O</sub>	Continuous output current	V <sub>O</sub> = 0 to V <sub>CC</sub>	±25	mA
Continuous current through V <sub>CC</sub> or GND			±50	mA
T <sub>J</sub>	Junction temperature		150	°C
T <sub>stg</sub>	Storage temperature	- 65	150	°C

- (1) Stresses beyond those listed under *Absolute Maximum Ratings* may cause permanent damage to the device. These are stress ratings only, which do not imply functional operation of the device at these or any other conditions beyond those indicated under *Recommended Operating Conditions*. Exposure to absolute-maximum-rated conditions for extended periods may affect device reliability.
- (2) The input and output voltage ratings may be exceeded if the input and output current ratings are observed.

### 5.2 ESD Ratings

		VALUE	UNIT
V <sub>(ESD)</sub>	Electrostatic discharge	Human body model (HBM), per ANSI/ESDA/JEDEC JS-001 <sup>(1)</sup>	±2000
		Charged device model (CDM), per JEDEC specification JESD22-C101 <sup>(2)</sup>	±1000

- (1) JEDEC document JEP155 states that 500-V HBM allows safe manufacturing with a standard ESD control process. Manufacturing with less than 500-V HBM is possible with the necessary precautions.
- (2) JEDEC document JEP157 states that 250-V CDM allows safe manufacturing with a standard ESD control process. Manufacturing with less than 250-V CDM is possible with the necessary precautions.

### 5.3 Recommended Operating Conditions

over operating free-air temperature range (unless otherwise noted)<sup>(1)</sup>

		MIN	MAX	UNIT
V <sub>CC</sub>	Supply voltage	2	5.5	V
V <sub>IH</sub>	High-level input voltage	V <sub>CC</sub> = 2 V	1.5	V
		V <sub>CC</sub> = 3 V	2.1	
		V <sub>CC</sub> = 5.5 V	3.85	
V <sub>IL</sub>	Low-level Input voltage	V <sub>CC</sub> = 2 V	0.5	V
		V <sub>CC</sub> = 3 V	0.9	
		V <sub>CC</sub> = 5.5 V	1.65	
V <sub>I</sub>	Input voltage	0	5.5	V
V <sub>O</sub>	Output voltage	0	V <sub>CC</sub>	V
I <sub>OH</sub>	High-level output current	V <sub>CC</sub> = 2 V	- 50	mA
		V <sub>CC</sub> = 3.3 V ± 0.3 V	- 4	
		V <sub>CC</sub> = 5 V ± 0.5 V	- 8	
I <sub>OL</sub>	Low-level output current	V <sub>CC</sub> = 2 V	50	mA
		V <sub>CC</sub> = 3.3 V ± 0.3 V	4	
		V <sub>CC</sub> = 5 V ± 0.5 V	8	
Δt / Δv	Input Transition rise or fall rate	V <sub>CC</sub> = 3.3 V ± 0.3 V	100	ns/V
		V <sub>CC</sub> = 5 V ± 0.5 V	20	

over operating free-air temperature range (unless otherwise noted)<sup>(1)</sup>

			MIN	MAX	UNIT
T <sub>A</sub>	Operating free-air temperature	SN54AHC08	- 55	125	°C
		SN74AHC08	- 40	125	

- (1) All unused inputs of the device must be held at V<sub>CC</sub> or GND to ensure proper device operation. Refer to the TI application report, *Implications of Slow or Floating CMOS Inputs*, [SCBA004](#).

## 5.4 Thermal Information

THERMAL METRIC <sup>(1)</sup>	SN74AHC08								UNIT	
	D (SOIC)	DB (SSOP)	DGV (TVSOP)	N (PDIP)	NS (SO)	PW (TSSOP)	RGY (VQFN)	BQA (WQFN)		
	14 PINS	14 PINS	14 PINS	14 PINS	14 PINS	14 PINS	14 PINS	14 PINS		
R <sub>θJA</sub>	Junction-to-ambient thermal resistance	124.5	96	127	80	76	147.7	87.1	88.3	°C/W

- (1) For more information about traditional and new thermal metrics, see the *Semiconductor and IC Package Thermal Metrics* application report, [SPRA953](#).

## 5.5 Electrical Characteristics, T<sub>A</sub> = 25°C

over operating free-air temperature range (unless otherwise noted)

PARAMETER	TEST CONDITIONS	V <sub>CC</sub>	MIN	TYP	MAX	UNIT
V <sub>OH</sub>	I <sub>OH</sub> = - 50 μA	2 V	1.9	2	V	
		3 V	2.9	3		
		4.5 V	4.4	4.5		
V <sub>OH</sub>	I <sub>OH</sub> = - 4 mA	3 V	2.58			
	I <sub>OH</sub> = - 8 mA	4.5 V	3.94			
V <sub>OL</sub>	I <sub>OL</sub> = 50 μA	2 V			0.1	V
		3 V			0.1	
		4.5 V			0.1	
	I <sub>OH</sub> = 4 mA	3 V			0.36	
	I <sub>OH</sub> = 8 mA	4.5 V			0.36	
I <sub>I</sub>	V <sub>I</sub> = 5.5 V or GND	0 V to 5.5 V			±0.1	μA
I <sub>CC</sub>	V <sub>I</sub> = V <sub>CC</sub> or GND, I <sub>O</sub> = 0	5.5 V			2	μA
C <sub>i</sub>	V <sub>I</sub> = V <sub>CC</sub> or GND	5 V		4	10	pF

## 5.6 Electrical Characteristics, $T_A = -55^\circ\text{C}$ to $125^\circ\text{C}$

over operating free-air temperature range (unless otherwise noted)

PARAMETER	TEST CONDITIONS	$V_{CC}$	SN54AHC08		UNIT
			MIN	MAX	
$V_{OH}$	$I_{OH} = -50\ \mu\text{A}$	2 V	1.9		V
		3 V	2.9		
		4.5 V	4.4		
	$I_{OH} = -4\ \text{mA}$	3 V	2.48		
		4.5 V	3.8		
$V_{OL}$	$I_{OL} = 50\ \mu\text{A}$	2 V		0.1	V
		3 V		0.1	
		4.5 V		0.1	
	$I_{OH} = 4\ \text{mA}$	3 V		0.5	
		4.5 V		0.5	
$I_I$	$V_I = 5.5\ \text{V}$ or GND	0 V to 5.5 V		$\pm 1^{(1)}$	$\mu\text{A}$
$I_{CC}$	$V_I = V_{CC}$ or GND, $I_O = 0$	5.5 V		20	$\mu\text{A}$
$C_i$	$V_I = V_{CC}$ or GND	5 V			pF

 (1) On products compliant to MIL-PRF-38535, this parameter is not production tested at  $V_{CC} = 0\ \text{V}$ .

## 5.7 Electrical Characteristics, $T_A = -40^\circ\text{C}$ to $125^\circ\text{C}$

over operating free-air temperature range (unless otherwise noted)

PARAMETER	TEST CONDITIONS	$V_{CC}$	$T_A$	SN74AHC08		UNIT
				MIN	MAX	
$V_{OH}$	$I_{OH} = -50\ \mu\text{A}$	2 V		1.9		V
		3 V		2.9		
		4.5 V		4.4		
	$I_{OH} = -4\ \text{mA}$	3 V		2.48		
		4.5 V		3.8		
$V_{OL}$	$I_{OL} = 50\ \mu\text{A}$	2 V			0.1	V
		3 V			0.1	
		4.5 V			0.1	
	$I_{OH} = 4\ \text{mA}$	3 V	$T_A = -40^\circ\text{C}$ to $85^\circ\text{C}$		0.44	
			$T_A = -40^\circ\text{C}$ to $125^\circ\text{C}$ Recommended		0.5	
	$I_{OH} = 8\ \text{mA}$	4.5 V	$T_A = -40^\circ\text{C}$ to $85^\circ\text{C}$		0.44	
			$T_A = -40^\circ\text{C}$ to $125^\circ\text{C}$ Recommended		0.5	
$I_I$	$V_I = 5.5\ \text{V}$ or GND	0 V to 5.5 V			$\pm 1$	$\mu\text{A}$
$I_{CC}$	$V_I = V_{CC}$ or GND, $I_O = 0$	5.5 V			20	$\mu\text{A}$
$C_i$	$V_I = V_{CC}$ or GND	5 V	$T_A = -40^\circ\text{C}$ to $85^\circ\text{C}$		10	pF

### 5.8 Switching Characteristics, $V_{CC} = 3.3 V \pm 0.3 V$

over recommended operating free-air temperature range (unless otherwise noted) (see [Load Circuit and Voltage Waveforms](#))

PARAMETER	FROM (INPUT)	TO (OUTPUT)	LOAD CAPACITANCE	$T_A$	MIN	TYP	MAX	UNIT
$t_{PLH}, t_{PHL}$	A or B	Y	$C_L = 15 \text{ pF}$	$T_A = 25^\circ\text{C}$		6.2 <sup>(1)</sup>	8.8 <sup>(1)</sup>	ns
				$T_A = -55^\circ\text{C to } 125^\circ\text{C, SN54AHC08}$		1 <sup>(1)</sup>	10.5 <sup>(1)</sup>	
				$T_A = -40^\circ\text{C to } 85^\circ\text{C, SN74AHC08}$		1	10.5	
				$T_A = -40^\circ\text{C to } 125^\circ\text{C Recommended, SN74AHC08}$		1	10.5	
$t_{PLH}, t_{PHL}$	A or B	Y	$C_L = 50 \text{ pF}$	$T_A = 25^\circ\text{C}$		8.7	12.3	ns
				$T_A = -55^\circ\text{C to } 125^\circ\text{C, SN54AHC08}$		1	14	
				$T_A = -40^\circ\text{C to } 85^\circ\text{C, SN74AHC08}$		1	14	
				$T_A = -40^\circ\text{C to } 125^\circ\text{C Recommended, SN74AHC08}$		1	14	

(1) On products compliant to MIL-PRF-38535, this parameter is not production tested.

### 5.9 Switching Characteristics, $V_{CC} = 5 V \pm 0.5 V$

over recommended operating free-air temperature range (unless otherwise noted) (see [Load Circuit and Voltage Waveforms](#))

PARAMETER	FROM (INPUT)	TO (OUTPUT)	LOAD CAPACITANCE	$T_A$	MIN	TYP	MAX	UNIT
$t_{PLH}, t_{PHL}$	A or B	Y	$C_L = 15 \text{ pF}$	$T_A = 25^\circ\text{C}$		4.3 <sup>(1)</sup>	5.9 <sup>(1)</sup>	ns
				$T_A = -55^\circ\text{C to } 125^\circ\text{C, SN54AHC08}$		1 <sup>(1)</sup>	7 <sup>(1)</sup>	
				$T_A = -40^\circ\text{C to } 85^\circ\text{C, SN74AHC08}$		1	7	
				$T_A = -40^\circ\text{C to } 125^\circ\text{C Recommended, SN74AHC08}$		1	7	
$t_{PLH}, t_{PHL}$	A or B	Y	$C_L = 50 \text{ pF}$	$T_A = 25^\circ\text{C}$		5.8	7.9	ns
				$T_A = -55^\circ\text{C to } 125^\circ\text{C, SN54AHC08}$		1	9	
				$T_A = -40^\circ\text{C to } 85^\circ\text{C, SN74AHC08}$		1	9	
				$T_A = -40^\circ\text{C to } 125^\circ\text{C Recommended, SN74AHC08}$		1	9	

(1) On products compliant to MIL-PRF-38535, this parameter is not production tested.

## 5.10 Noise Characteristics

 $V_{CC} = 5\text{ V}$ ,  $C_L = 50\text{ pF}$ ,  $T_A = 25^\circ\text{C}$ <sup>(1)</sup>

		SN74AHC08		UNIT
		MIN	MAX	
$V_{OL(P)}$	Quiet output, maximum dynamic $V_{OL}$		0.8	V
$V_{OL(V)}$	Quiet output, minimum dynamic $V_{OL}$		- 0.8	V
$V_{OH(V)}$	Quiet output, minimum dynamic $V_{OH}$	4.4		V
$V_{IH(D)}$	High-level dynamic input voltage	3.5		V
$V_{IL(D)}$	Low-level dynamic input voltage		1.5	V

(1) Characteristics are for surface-mount packages only.

## 5.11 Operating Characteristics

 $V_{CC} = 5\text{ V}$ ,  $T_A = 25^\circ\text{C}$ 

PARAMETER		TEST CONDITIONS	TYP	UNIT
$C_{pd}$	Power dissipation capacitance	No load, $f = 1\text{ MHz}$	18	pF

### 5.12 Typical Characteristics



图 5-1. AHC Family  $V_{OL}$  vs  $I_{OL}$

## 6 Parameter Measurement Information

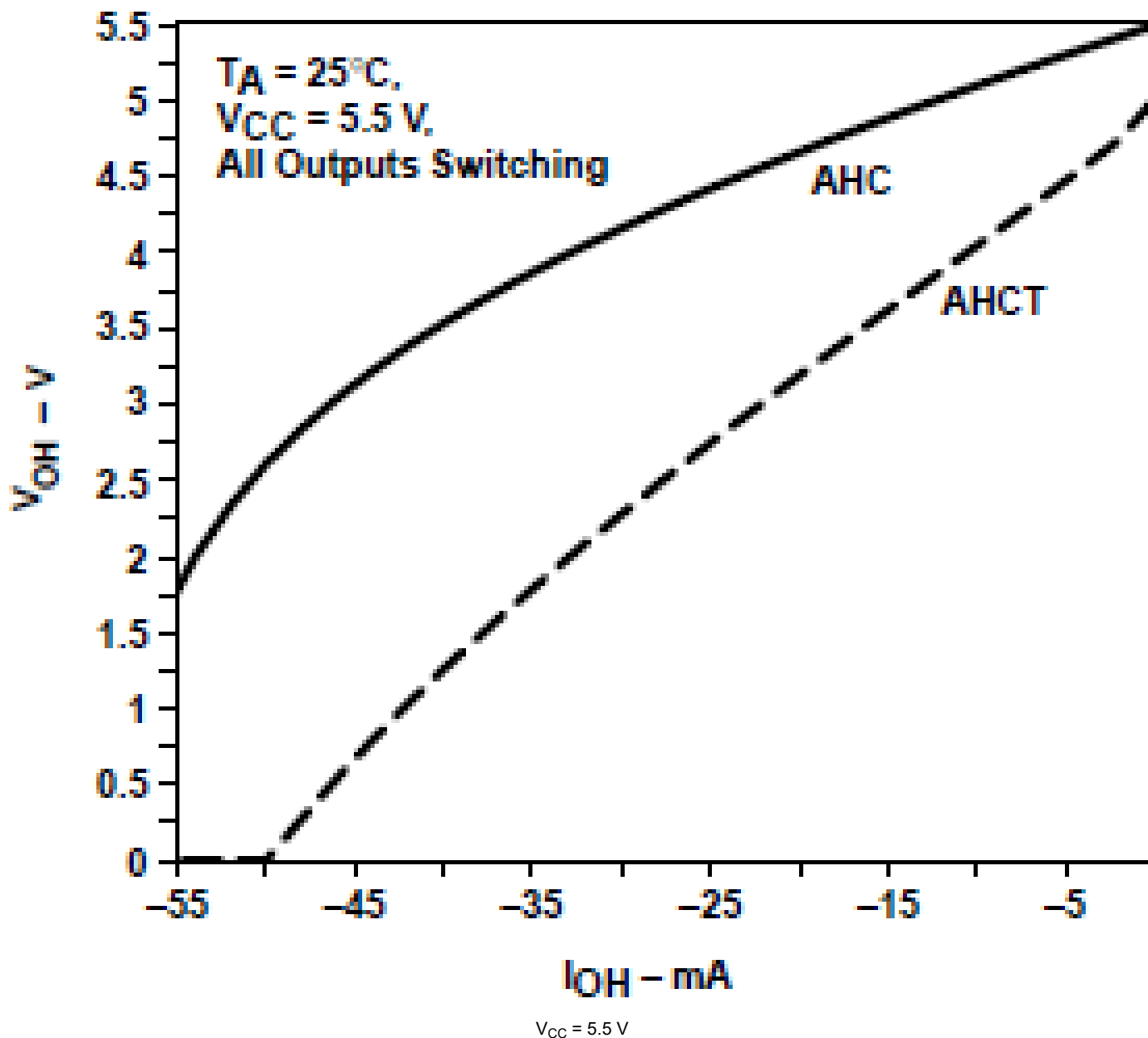
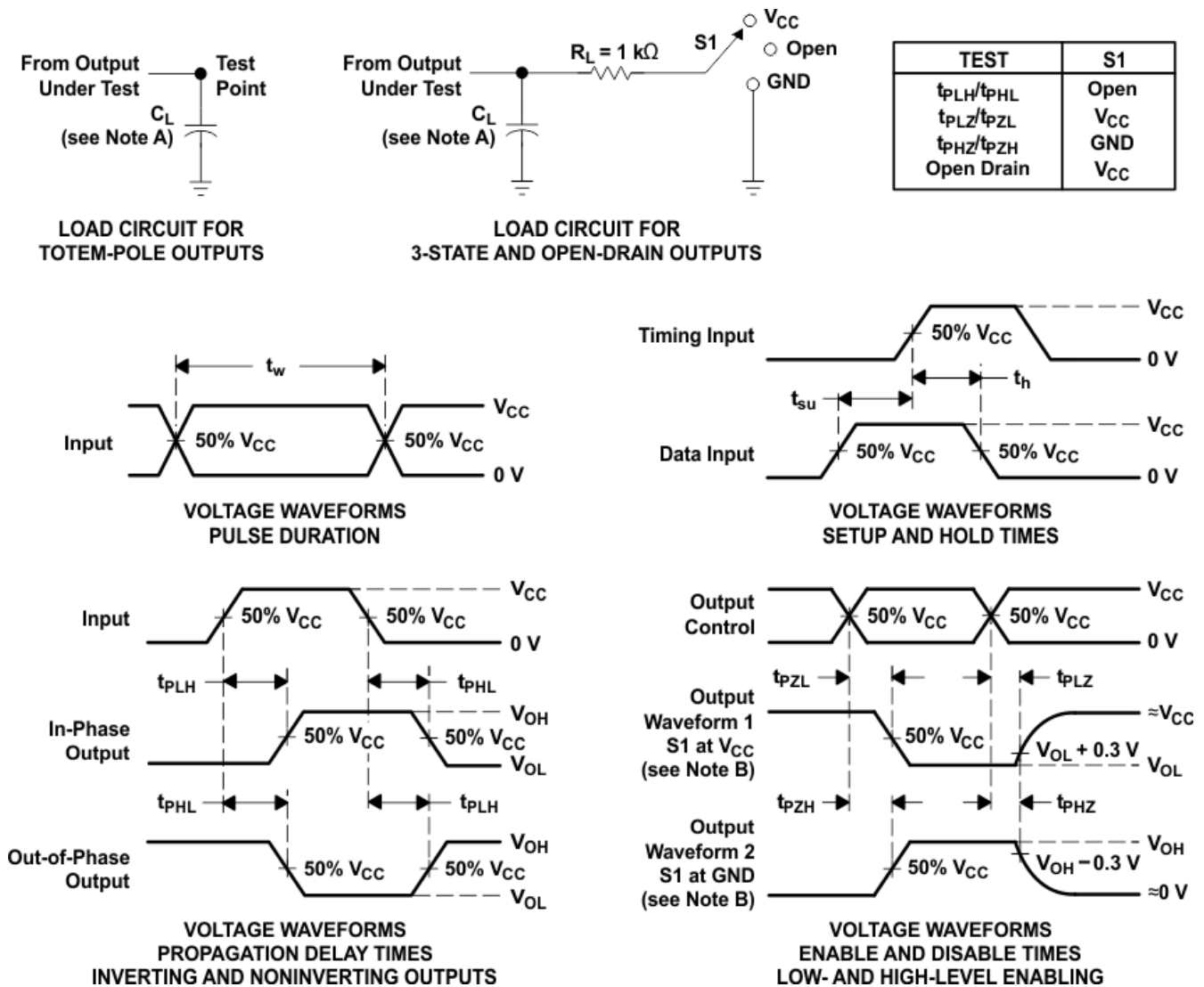

- A.  $C_L$  includes probe and jig capacitance.
- B. Waveform 1 is for an output with internal conditions such that the output is low except when disabled by the output control. Waveform 2 is for an output with internal conditions such that the output is high except when disabled by the output control.
- C. All input pulses are supplied by generators having the following characteristics:  $PRR \leq 1$  MHz,  $Z_O = 50 \Omega$ ,  $t_r \leq 3$  ns,  $t_f \leq 3$  ns.
- D. The outputs are measured one at a time with one input transition per measurement.
- E. All parameters and waveforms are not applicable to all devices.

图 6-1. Load Circuit and Voltage Waveforms

## 7 Detailed Description

### 7.1 Overview

The SNx4AHC08 devices are quadruple 2-input positive-AND gates with low drive that will produce slow rise and fall times. This slow transition reduces ringing on the output signal. The inputs are high impedance when  $V_{CC} = 0$  V.

### 7.2 Functional Block Diagram

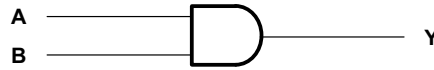

### 7.3 Feature Description

Slow rise and fall time on outputs allow for low-noise outputs.

### 7.4 Device Functional Modes

表 7-1 is the function table for the SNx4AHC08.

表 7-1. Function Table  
(Each Gate)

INPUTS		OUTPUT Y
A	B	
H	H	H
L	X	L
X	L	L

## 8 Application and Implementation

### 备注

以下应用部分中的信息不属于 TI 器件规格的范围，TI 不担保其准确性和完整性。TI 的客户应负责确定器件是否适用于其应用。客户应验证并测试其设计，以确保系统功能。

### 8.1 Application Information

A common application for AND gates is the use in power sequencing. Power sequencing is often employed in applications that require a processor or other delicate device with specific voltage timing requirements in order to protect the device from malfunctioning. Using the SN74AHC08 to verify that the processor has turned on can protect it from harmful signals.

### 8.2 Typical Application



图 8-1. Typical Application Diagram

#### 8.2.1 Design Requirements

This device uses CMOS technology and has balanced output drive. Take care to avoid bus contention because it can drive currents that would exceed maximum limits. The high drive will also create fast edges into light loads, so routing and load conditions must be considered to prevent ringing.

#### 8.2.2 Detailed Design Procedure

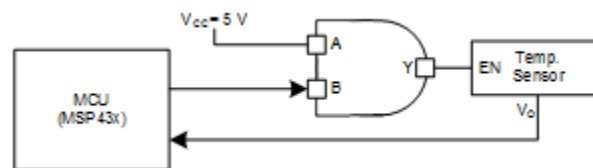
- Recommended input conditions
  - Rise time and fall time specs: See ( $\Delta t / \Delta v$ ) in the [节 5.3](#) table.
  - Specified High and low levels: See ( $V_{IH}$  and  $V_{IL}$ ) in the [节 5.3](#) table.
  - Inputs are overvoltage tolerant allowing them to go as high as 5.5 V at any valid  $V_{CC}$
- Recommend output conditions
  - Load currents should not exceed 25 mA per output and 50 mA total for the part
  - Outputs should not be pulled above  $V_{CC}$

### 8.2.3 Application Curve



图 8-2. AHC Family  $V_{OH}$  vs  $I_{OH}$

#### Power Supply Recommendations

The power supply can be any voltage between the minimum and maximum supply voltage rating located in the [节 5.1](#) table.

Each  $V_{CC}$  pin should have a good bypass capacitor to prevent power disturbance. For devices with a single supply,  $0.1\ \mu\text{F}$  is recommended. If there are multiple  $V_{CC}$  pins,  $0.01\ \mu\text{F}$  or  $0.022\ \mu\text{F}$  is recommended for each power pin. It is acceptable to parallel multiple bypass caps to reject different frequencies of noise. A  $0.1\ \mu\text{F}$  and

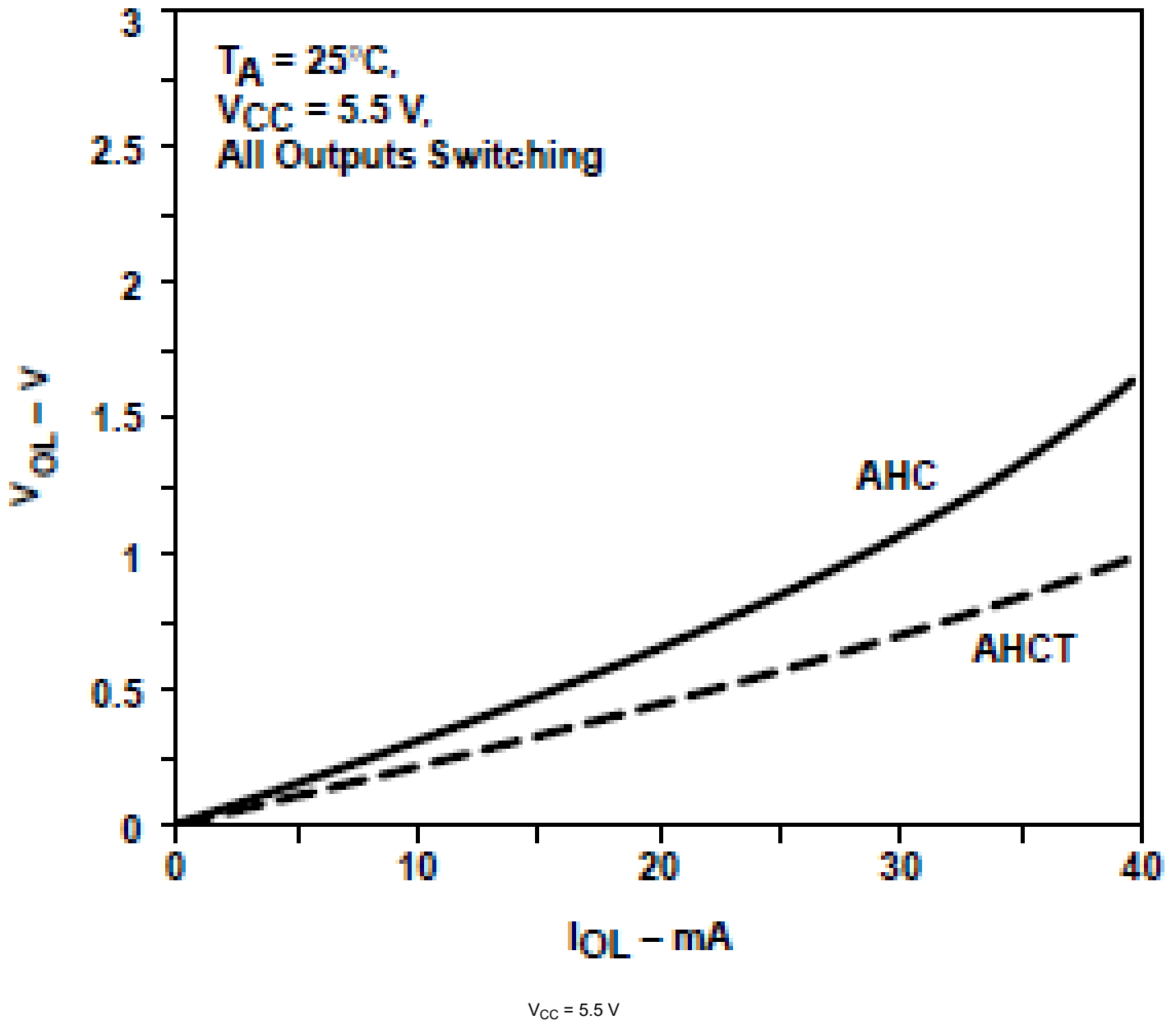
1  $\mu\text{F}$  are commonly used in parallel. The bypass capacitor should be installed as close to the power pin as possible for best results.

### 8.3 Layout

#### 8.3.1 Layout Guidelines

When using multiple bit logic devices inputs should not ever float.

In many cases, functions or parts of functions of digital logic devices are unused, for example, when only two inputs of a triple-input AND gate are used or only 3 of the 4 buffer gates are used. Such input pins should not be left unconnected because the undefined voltages at the outside connections result in undefined operational states. Specified in [图 8-3](#) are the rules that must be observed under all circumstances. All unused inputs of digital logic devices must be connected to a high or low bias to prevent them from floating. The logic level that must be applied to any particular unused input depends on the function of the device. Generally they will be tied to GND or  $V_{CC}$ ; whichever makes more sense or is more convenient. It is generally acceptable to float outputs unless the part is a transceiver. If the transceiver has an output enable pin, it will disable the outputs section of the part when asserted. This will not disable the input section of the IOs, so they cannot float when disabled.

##### 8.3.1.1 Layout Example

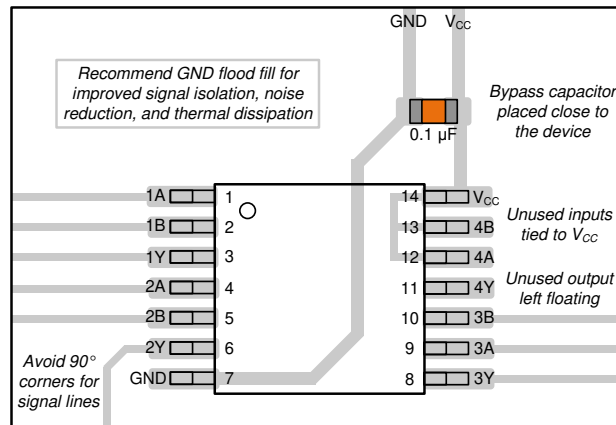

**图 8-3. Layout Example for the SNx4AHC08**

## 9 Device and Documentation Support

### 9.1 Documentation Support

#### 9.1.1 Related Documentation

The table below lists quick access links. Categories include technical documents, support and community resources, tools and software, and quick access to sample or buy.

表 9-1. Related Links

PARTS	PRODUCT FOLDER	SAMPLE & BUY	TECHNICAL DOCUMENTS	TOOLS & SOFTWARE	SUPPORT & COMMUNITY
SN54AHC08	<a href="#">Click here</a>	<a href="#">Click here</a>	<a href="#">Click here</a>	<a href="#">Click here</a>	<a href="#">Click here</a>
SN74AHC08	<a href="#">Click here</a>	<a href="#">Click here</a>	<a href="#">Click here</a>	<a href="#">Click here</a>	<a href="#">Click here</a>

### 9.2 接收文档更新通知

要接收文档更新通知，请导航至 [ti.com](http://ti.com) 上的器件产品文件夹。点击 [通知](#) 进行注册，即可每周接收产品信息更改摘要。有关更改的详细信息，请查看任何已修订文档中包含的修订历史记录。

### 9.3 支持资源

TI E2E™ [中文支持论坛](#) 是工程师的重要参考资料，可直接从专家处获得快速、经过验证的解答和设计帮助。搜索现有解答或提出自己的问题，获得所需的快速设计帮助。

链接的内容由各个贡献者“按原样”提供。这些内容并不构成 TI 技术规范，并且不一定反映 TI 的观点；请参阅 TI 的 [使用条款](#)。

### 9.4 Trademarks

TI E2E™ is a trademark of Texas Instruments.

所有商标均为其各自所有者的财产。

### 9.5 静电放电警告



静电放电 (ESD) 会损坏这个集成电路。德州仪器 (TI) 建议通过适当的预防措施处理所有集成电路。如果不遵守正确的处理和安装程序，可能会损坏集成电路。

ESD 的损坏小至导致微小的性能降级，大至整个器件故障。精密的集成电路可能更容易受到损坏，这是因为非常细微的参数更改都可能会导致器件与其发布的规格不相符。

### 9.6 术语表

[TI 术语表](#) 本术语表列出并解释了术语、首字母缩略词和定义。

## 10 Revision History

注：以前版本的页码可能与当前版本的页码不同

Changes from Revision K (June 2023) to Revision L (February 2024)	Page
• Updated R <sup>θ</sup> JA value: RGY = 47 to 87.1, all values in °C/W .....	6

Changes from Revision J (December 2015) to Revision K (June 2023)	Page
• 向 <a href="#">器件信息</a> 表中添加了 BQA 封装.....	1
• Updated R <sup>θ</sup> JA values: D = 86 to 124.5, PW = 113 to 147.7 .....	6
• Added thermal value for R <sup>θ</sup> JA: BQA = 88.3, all values in °C/W.....	6

## 11 Mechanical, Packaging, and Orderable Information

The following pages include mechanical, packaging, and orderable information. This information is the most current data available for the designated devices. This data is subject to change without notice and revision of this document. For browser-based versions of this data sheet, refer to the left-hand navigation.

**PACKAGING INFORMATION**

Orderable part number	Status (1)	Material type (2)	Package   Pins	Package qty   Carrier	RoHS (3)	Lead finish/ Ball material (4)	MSL rating/ Peak reflow (5)	Op temp (°C)	Part marking (6)
<a href="#">5962-9682001Q2A</a>	Active	Production	LCCC (FK)   20	55   TUBE	No	SNPB	N/A for Pkg Type	-55 to 125	5962-9682001Q2A SNJ54AHC 08FK
<a href="#">SN74AHC08BQAR</a>	Active	Production	WQFN (BQA)   14	3000   LARGE T&R	Yes	SN	Level-1-260C-UNLIM	-40 to 125	AHC08
SN74AHC08BQAR.A	Active	Production	WQFN (BQA)   14	3000   LARGE T&R	Yes	SN	Level-1-260C-UNLIM	-40 to 125	AHC08
<a href="#">SN74AHC08D</a>	Obsolete	Production	SOIC (D)   14	-	-	Call TI	Call TI	-40 to 125	AHC08
<a href="#">SN74AHC08DBR</a>	Active	Production	SSOP (DB)   14	2000   LARGE T&R	Yes	NIPDAU	Level-1-260C-UNLIM	-40 to 125	HA08
SN74AHC08DBR.A	Active	Production	SSOP (DB)   14	2000   LARGE T&R	Yes	NIPDAU	Level-1-260C-UNLIM	-40 to 125	HA08
<a href="#">SN74AHC08DGVR</a>	NRND	Production	TVSOP (DGV)   14	2000   LARGE T&R	Yes	NIPDAU	Level-1-260C-UNLIM	-40 to 125	HA08
SN74AHC08DGVR.A	NRND	Production	TVSOP (DGV)   14	2000   LARGE T&R	Yes	NIPDAU	Level-1-260C-UNLIM	-40 to 125	HA08
<a href="#">SN74AHC08DR</a>	Active	Production	SOIC (D)   14	2500   LARGE T&R	Yes	NIPDAU	Level-1-260C-UNLIM	-40 to 125	AHC08
SN74AHC08DR.A	Active	Production	SOIC (D)   14	2500   LARGE T&R	Yes	NIPDAU	Level-1-260C-UNLIM	-40 to 125	AHC08
SN74AHC08DR1G4	Active	Production	SOIC (D)   14	2500   LARGE T&R	Yes	NIPDAU	Level-1-260C-UNLIM	-40 to 125	AHC08
SN74AHC08DR1G4.A	Active	Production	SOIC (D)   14	2500   LARGE T&R	Yes	NIPDAU	Level-1-260C-UNLIM	-40 to 125	AHC08
<a href="#">SN74AHC08N</a>	Active	Production	PDIP (N)   14	25   TUBE	Yes	NIPDAU	N/A for Pkg Type	-40 to 125	SN74AHC08N
SN74AHC08N.A	Active	Production	PDIP (N)   14	25   TUBE	Yes	NIPDAU	N/A for Pkg Type	-40 to 125	SN74AHC08N
<a href="#">SN74AHC08NSR</a>	NRND	Production	SOP (NS)   14	2000   LARGE T&R	Yes	NIPDAU	Level-1-260C-UNLIM	-40 to 125	AHC08
SN74AHC08NSR.A	NRND	Production	SOP (NS)   14	2000   LARGE T&R	Yes	NIPDAU	Level-1-260C-UNLIM	-40 to 125	AHC08
<a href="#">SN74AHC08PW</a>	Obsolete	Production	TSSOP (PW)   14	-	-	Call TI	Call TI	-40 to 125	HA08
<a href="#">SN74AHC08PWR</a>	Active	Production	TSSOP (PW)   14	2000   LARGE T&R	Yes	NIPDAU   SN	Level-1-260C-UNLIM	-40 to 125	HA08
SN74AHC08PWR.A	Active	Production	TSSOP (PW)   14	2000   LARGE T&R	Yes	NIPDAU	Level-1-260C-UNLIM	-40 to 125	HA08
<a href="#">SN74AHC08PWRG4</a>	Active	Production	TSSOP (PW)   14	2000   LARGE T&R	Yes	NIPDAU	Level-1-260C-UNLIM	-40 to 125	HA08
SN74AHC08PWRG4.A	Active	Production	TSSOP (PW)   14	2000   LARGE T&R	Yes	NIPDAU	Level-1-260C-UNLIM	-40 to 125	HA08
<a href="#">SN74AHC08RGYR</a>	Active	Production	VQFN (RGY)   14	3000   LARGE T&R	Yes	NIPDAU	Level-1-260C-UNLIM	-40 to 125	HA08
SN74AHC08RGYR.A	Active	Production	VQFN (RGY)   14	3000   LARGE T&R	Yes	NIPDAU	Level-1-260C-UNLIM	-40 to 125	HA08
SN74AHC08RGYRG4	Active	Production	VQFN (RGY)   14	3000   LARGE T&R	Yes	NIPDAU	Level-1-260C-UNLIM	-40 to 125	HA08
SN74AHC08RGYRG4.A	Active	Production	VQFN (RGY)   14	3000   LARGE T&R	Yes	NIPDAU	Level-1-260C-UNLIM	-40 to 125	HA08

Orderable part number	Status (1)	Material type (2)	Package   Pins	Package qty   Carrier	RoHS (3)	Lead finish/ Ball material (4)	MSL rating/ Peak reflow (5)	Op temp (°C)	Part marking (6)
SNJ54AHC08FK	Active	Production	LCCC (FK)   20	55   TUBE	No	SNPB	N/A for Pkg Type	-55 to 125	5962- 9682001Q2A SNJ54AHC 08FK

<sup>(1)</sup> **Status:** For more details on status, see our [product life cycle](#).

<sup>(2)</sup> **Material type:** When designated, preproduction parts are prototypes/experimental devices, and are not yet approved or released for full production. Testing and final process, including without limitation quality assurance, reliability performance testing, and/or process qualification, may not yet be complete, and this item is subject to further changes or possible discontinuation. If available for ordering, purchases will be subject to an additional waiver at checkout, and are intended for early internal evaluation purposes only. These items are sold without warranties of any kind.

<sup>(3)</sup> **RoHS values:** Yes, No, RoHS Exempt. See the [TI RoHS Statement](#) for additional information and value definition.

<sup>(4)</sup> **Lead finish/Ball material:** Parts may have multiple material finish options. Finish options are separated by a vertical ruled line. Lead finish/Ball material values may wrap to two lines if the finish value exceeds the maximum column width.

<sup>(5)</sup> **MSL rating/Peak reflow:** The moisture sensitivity level ratings and peak solder (reflow) temperatures. In the event that a part has multiple moisture sensitivity ratings, only the lowest level per JEDEC standards is shown. Refer to the shipping label for the actual reflow temperature that will be used to mount the part to the printed circuit board.

<sup>(6)</sup> **Part marking:** There may be an additional marking, which relates to the logo, the lot trace code information, or the environmental category of the part.

Multiple part markings will be inside parentheses. Only one part marking contained in parentheses and separated by a "~" will appear on a part. If a line is indented then it is a continuation of the previous line and the two combined represent the entire part marking for that device.

**Important Information and Disclaimer:**The information provided on this page represents TI's knowledge and belief as of the date that it is provided. TI bases its knowledge and belief on information provided by third parties, and makes no representation or warranty as to the accuracy of such information. Efforts are underway to better integrate information from third parties. TI has taken and continues to take reasonable steps to provide representative and accurate information but may not have conducted destructive testing or chemical analysis on incoming materials and chemicals. TI and TI suppliers consider certain information to be proprietary, and thus CAS numbers and other limited information may not be available for release.

In no event shall TI's liability arising out of such information exceed the total purchase price of the TI part(s) at issue in this document sold by TI to Customer on an annual basis.

**OTHER QUALIFIED VERSIONS OF SN54AHC08, SN74AHC08 :**

- Catalog : [SN74AHC08](#)

- Enhanced Product : [SN74AHC08-EP](#), [SN74AHC08-EP](#)

- Military : [SN54AHC08](#)

NOTE: Qualified Version Definitions:

- Catalog - TI's standard catalog product
- Enhanced Product - Supports Defense, Aerospace and Medical Applications
- Military - QML certified for Military and Defense Applications

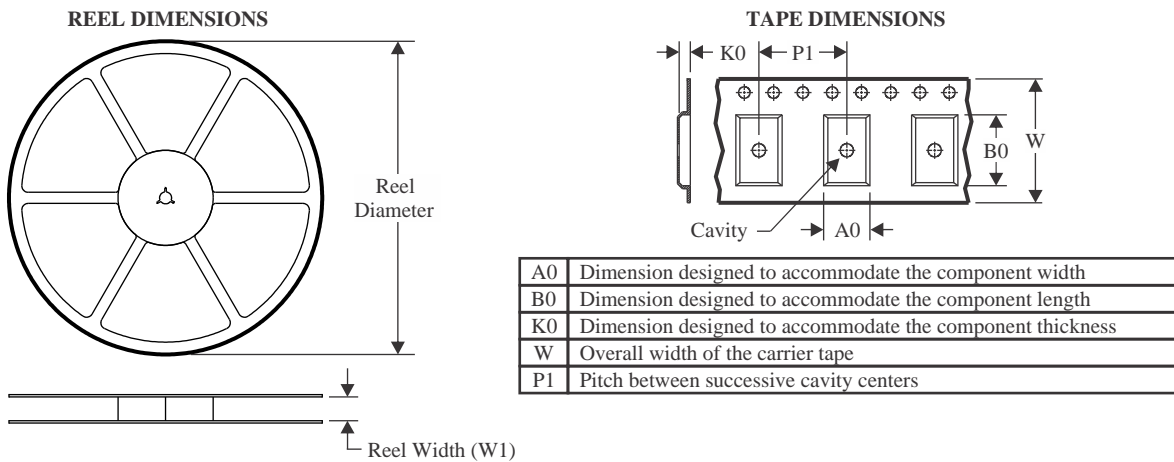
**TAPE AND REEL INFORMATION**

**QUADRANT ASSIGNMENTS FOR PIN 1 ORIENTATION IN TAPE**

\*All dimensions are nominal

Device	Package Type	Package Drawing	Pins	SPQ	Reel Diameter (mm)	Reel Width W1 (mm)	A0 (mm)	B0 (mm)	K0 (mm)	P1 (mm)	W (mm)	Pin1 Quadrant
SN74AHC08BQAR	WQFN	BQA	14	3000	180.0	12.4	2.8	3.3	1.1	4.0	12.0	Q1
SN74AHC08DBR	SSOP	DB	14	2000	330.0	16.4	8.35	6.6	2.4	12.0	16.0	Q1
SN74AHC08DGVR	TVSOP	DGV	14	2000	330.0	12.4	6.8	4.0	1.6	8.0	12.0	Q1
SN74AHC08DR	SOIC	D	14	2500	330.0	12.4	3.75	3.75	1.15	8.0	12.0	Q1
SN74AHC08DR1G4	SOIC	D	14	2500	330.0	16.4	6.5	9.0	2.1	8.0	16.0	Q1
SN74AHC08NSR	SOP	NS	14	2000	330.0	16.4	8.1	10.4	2.5	12.0	16.0	Q1
SN74AHC08PWR	TSSOP	PW	14	2000	330.0	12.4	6.9	5.6	1.6	8.0	12.0	Q1
SN74AHC08PWRG4	TSSOP	PW	14	2000	330.0	12.4	6.9	5.6	1.6	8.0	12.0	Q1
SN74AHC08PWRG4	TSSOP	PW	14	2000	330.0	12.4	6.9	5.3	1.6	8.0	12.0	Q1
SN74AHC08RGYR	VQFN	RGY	14	3000	330.0	12.4	3.75	3.75	1.15	8.0	12.0	Q1
SN74AHC08RGYRG4	VQFN	RGY	14	3000	330.0	12.4	3.75	3.75	1.15	8.0	12.0	Q1

**TAPE AND REEL BOX DIMENSIONS**

\*All dimensions are nominal

Device	Package Type	Package Drawing	Pins	SPQ	Length (mm)	Width (mm)	Height (mm)
SN74AHC08BQAR	WQFN	BQA	14	3000	210.0	185.0	35.0
SN74AHC08DBR	SSOP	DB	14	2000	353.0	353.0	32.0
SN74AHC08DGVR	TVSOP	DGV	14	2000	353.0	353.0	32.0
SN74AHC08DR	SOIC	D	14	2500	340.5	336.1	32.0
SN74AHC08DR1G4	SOIC	D	14	2500	353.0	353.0	32.0
SN74AHC08NSR	SOP	NS	14	2000	353.0	353.0	32.0
SN74AHC08PWR	TSSOP	PW	14	2000	356.0	356.0	35.0
SN74AHC08PWRG4	TSSOP	PW	14	2000	353.0	353.0	32.0
SN74AHC08PWRG4	TSSOP	PW	14	2000	367.0	367.0	35.0
SN74AHC08RGYR	VQFN	RGY	14	3000	360.0	360.0	36.0
SN74AHC08RGYRG4	VQFN	RGY	14	3000	360.0	360.0	36.0

**TUBE**

\*All dimensions are nominal

Device	Package Name	Package Type	Pins	SPQ	L (mm)	W (mm)	T (μm)	B (mm)
5962-9682001Q2A	FK	LCCC	20	55	506.98	12.06	2030	NA
SN74AHC08N	N	PDIP	14	25	506	13.97	11230	4.32
SN74AHC08N	N	PDIP	14	25	506	13.97	11230	4.32
SN74AHC08N.A	N	PDIP	14	25	506	13.97	11230	4.32
SN74AHC08N.A	N	PDIP	14	25	506	13.97	11230	4.32
SNJ54AHC08FK	FK	LCCC	20	55	506.98	12.06	2030	NA

## GENERIC PACKAGE VIEW

**RGY 14**

**VQFN - 1 mm max height**

3.5 x 3.5, 0.5 mm pitch

PLASTIC QUAD FLATPACK - NO LEAD

This image is a representation of the package family, actual package may vary.  
Refer to the product data sheet for package details.

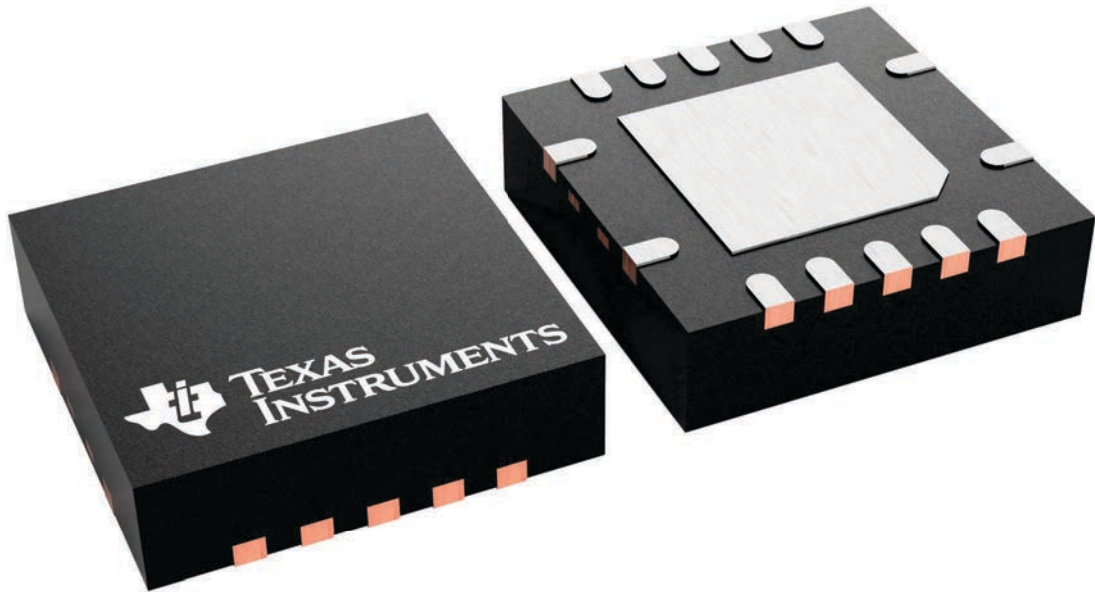

4231541/A

RGY0014A

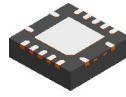

PACKAGE OUTLINE

VQFN - 1 mm max height

PLASTIC QUAD FLATPACK - NO LEAD

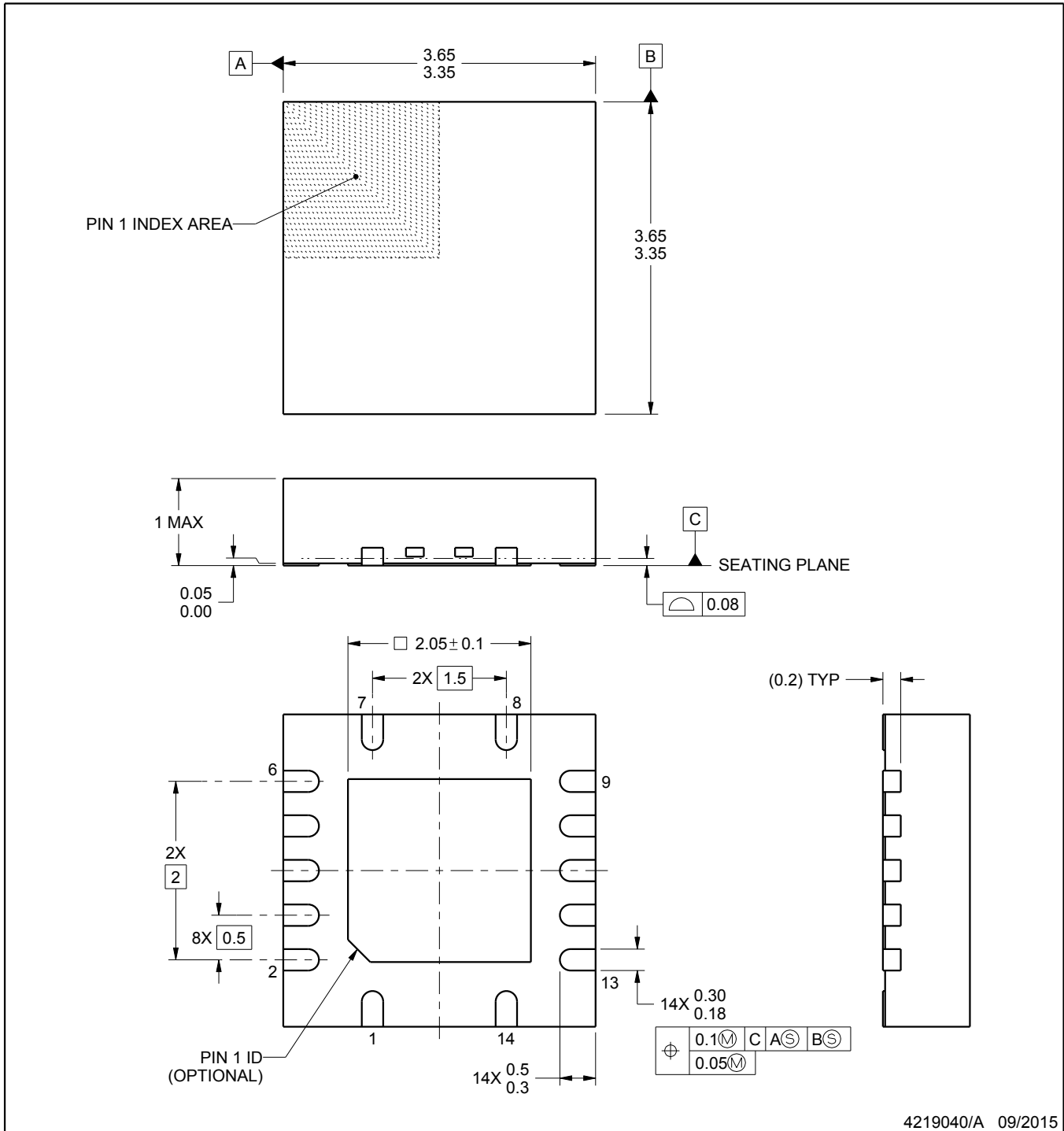

4219040/A 09/2015

NOTES:

1. All linear dimensions are in millimeters. Any dimensions in parenthesis are for reference only. Dimensioning and tolerancing per ASME Y14.5M.
2. This drawing is subject to change without notice.
3. The package thermal pad must be soldered to the printed circuit board for thermal and mechanical performance.

# EXAMPLE BOARD LAYOUT

RGY0014A

VQFN - 1 mm max height

PLASTIC QUAD FLATPACK - NO LEAD

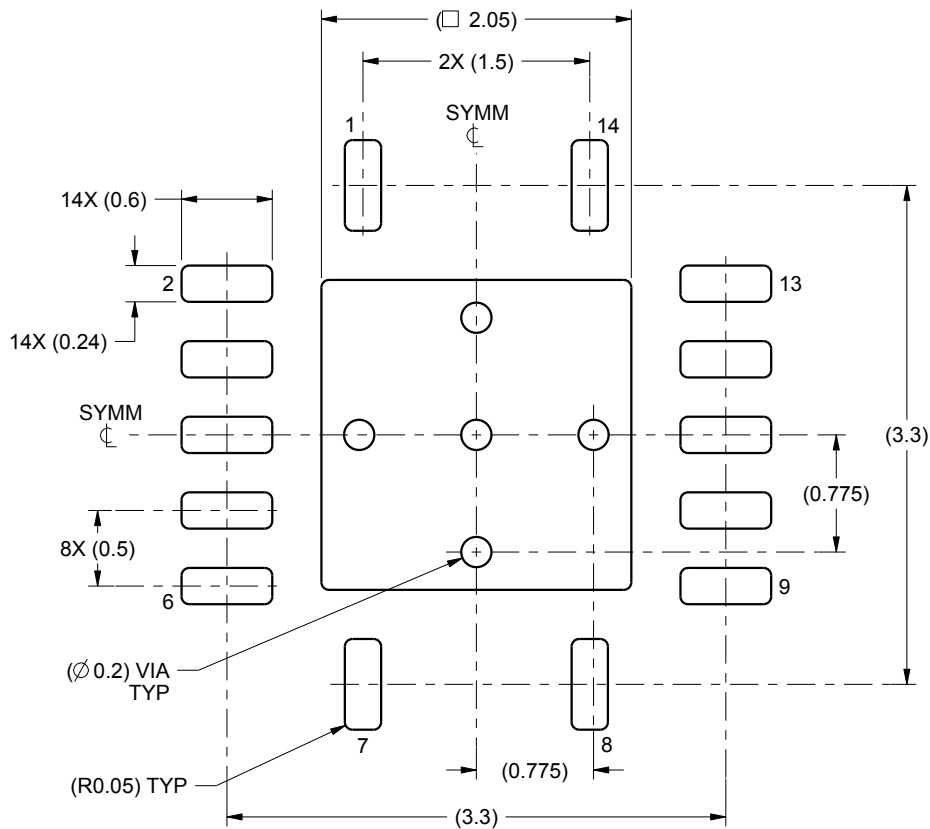

LAND PATTERN EXAMPLE  
SCALE:20X

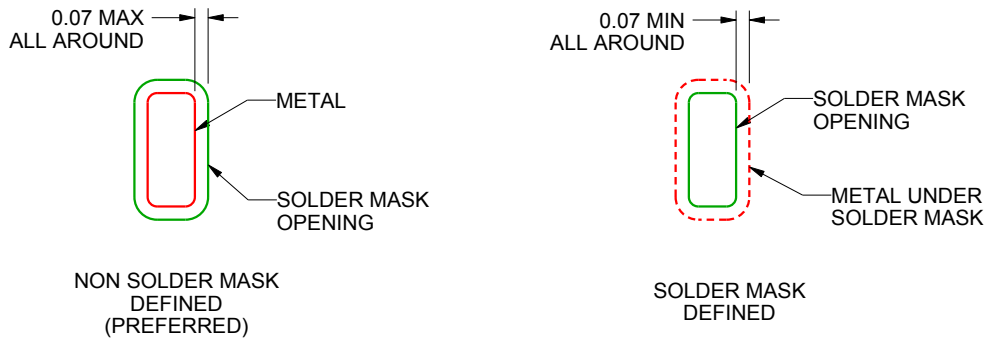

SOLDER MASK DETAILS

4219040/A 09/2015

NOTES: (continued)

4. This package is designed to be soldered to a thermal pad on the board. For more information, see Texas Instruments literature number SLUA271 ([www.ti.com/lit/sluea271](http://www.ti.com/lit/sluea271)).

# EXAMPLE STENCIL DESIGN

RGY0014A

VQFN - 1 mm max height

PLASTIC QUAD FLATPACK - NO LEAD

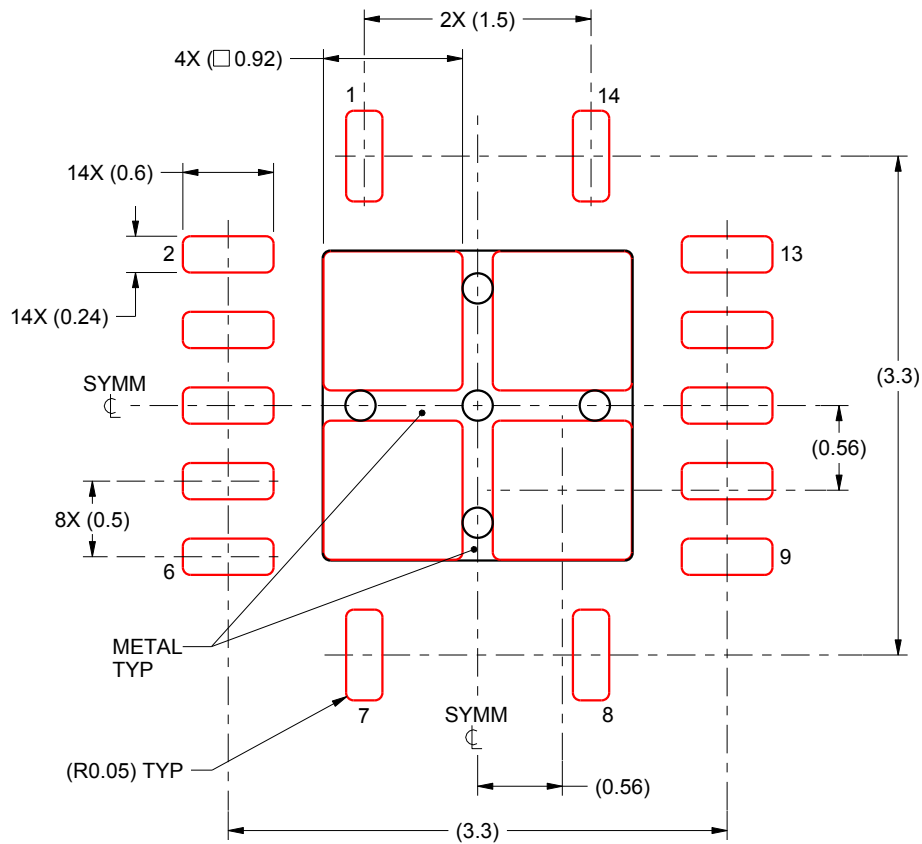

**SOLDER PASTE EXAMPLE**  
BASED ON 0.125 mm THICK STENCIL

EXPOSED PAD  
80% PRINTED SOLDER COVERAGE BY AREA  
SCALE:20X

4219040/A 09/2015

NOTES: (continued)

5. Laser cutting apertures with trapezoidal walls and rounded corners may offer better paste release. IPC-7525 may have alternate design recommendations.

D0014A



# PACKAGE OUTLINE

## SOIC - 1.75 mm max height

SMALL OUTLINE INTEGRATED CIRCUIT

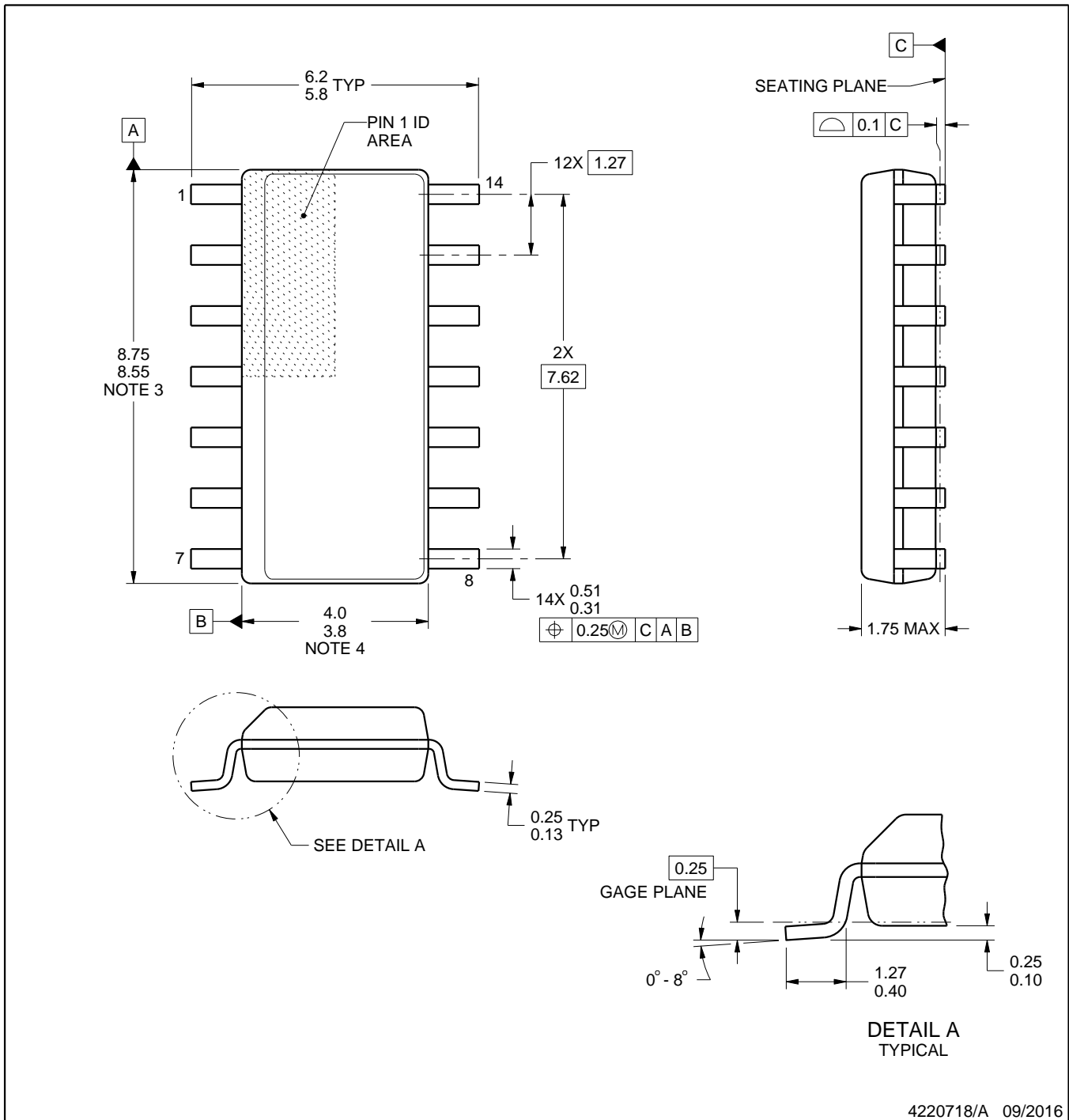

4220718/A 09/2016

NOTES:

1. All linear dimensions are in millimeters. Dimensions in parenthesis are for reference only. Dimensioning and tolerancing per ASME Y14.5M.
2. This drawing is subject to change without notice.
3. This dimension does not include mold flash, protrusions, or gate burrs. Mold flash, protrusions, or gate burrs shall not exceed 0.15 mm, per side.
4. This dimension does not include interlead flash. Interlead flash shall not exceed 0.43 mm, per side.
5. Reference JEDEC registration MS-012, variation AB.

# EXAMPLE BOARD LAYOUT

D0014A

SOIC - 1.75 mm max height

SMALL OUTLINE INTEGRATED CIRCUIT



LAND PATTERN EXAMPLE  
SCALE:8X



SOLDER MASK DETAILS

4220718/A 09/2016

NOTES: (continued)

- 6. Publication IPC-7351 may have alternate designs.
- 7. Solder mask tolerances between and around signal pads can vary based on board fabrication site.

# EXAMPLE STENCIL DESIGN

D0014A

SOIC - 1.75 mm max height

SMALL OUTLINE INTEGRATED CIRCUIT



SOLDER PASTE EXAMPLE  
BASED ON 0.125 mm THICK STENCIL  
SCALE:8X

4220718/A 09/2016

NOTES: (continued)

8. Laser cutting apertures with trapezoidal walls and rounded corners may offer better paste release. IPC-7525 may have alternate design recommendations.
9. Board assembly site may have different recommendations for stencil design.

## GENERIC PACKAGE VIEW

**BQA 14**

**WQFN - 0.8 mm max height**

2.5 x 3, 0.5 mm pitch

PLASTIC QUAD FLATPACK - NO LEAD

This image is a representation of the package family, actual package may vary.  
Refer to the product data sheet for package details.

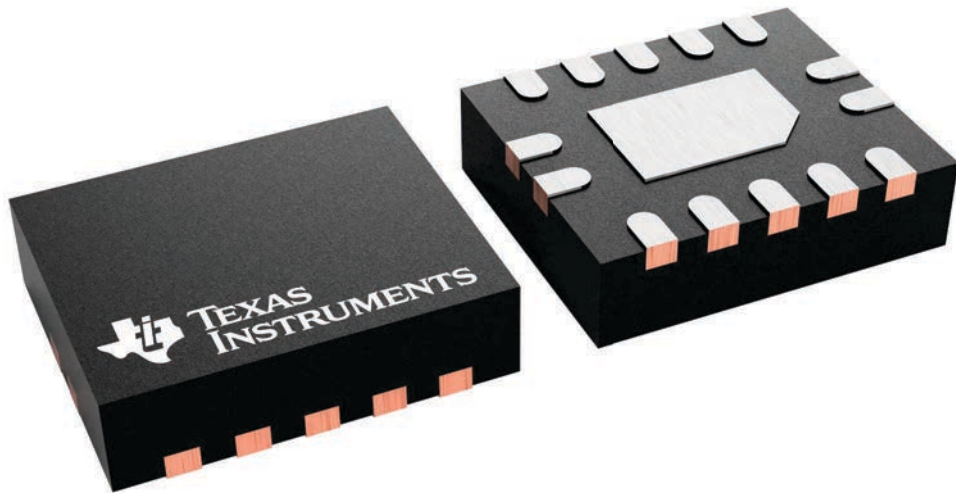

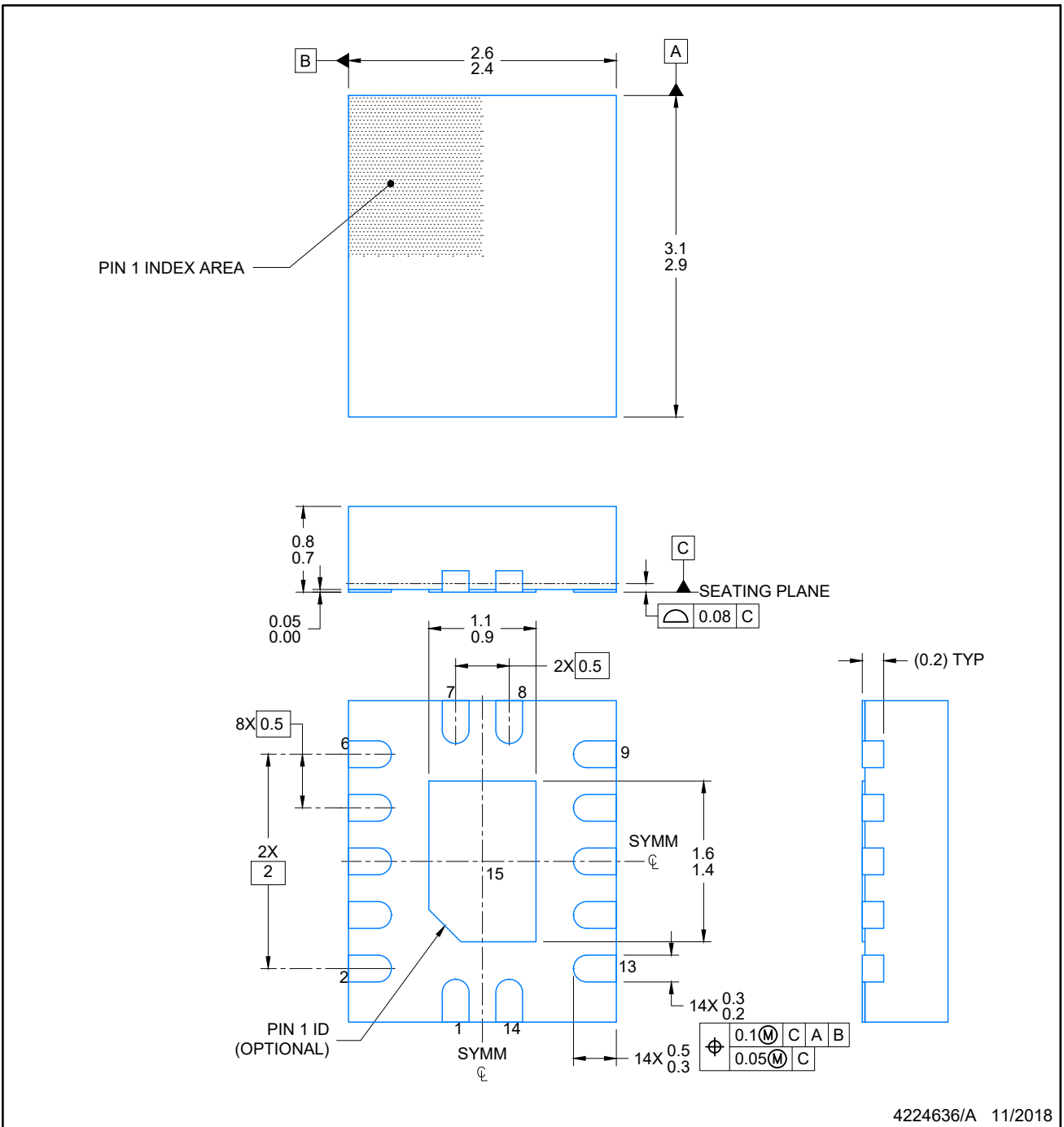

**NOTES:**

1. All linear dimensions are in millimeters. Any dimensions in parenthesis are for reference only. Dimensioning and tolerancing per ASME Y14.5M.
2. This drawing is subject to change without notice.
3. The package thermal pad must be soldered to the printed circuit board for optimal thermal and mechanical performance.

# EXAMPLE BOARD LAYOUT

WQFN - 0.8 mm max height

BQA0014A

PLASTIC QUAD FLAT PACK-NO LEAD



LAND PATTERN EXAMPLE  
EXPOSED METAL SHOWN  
SCALE: 20X

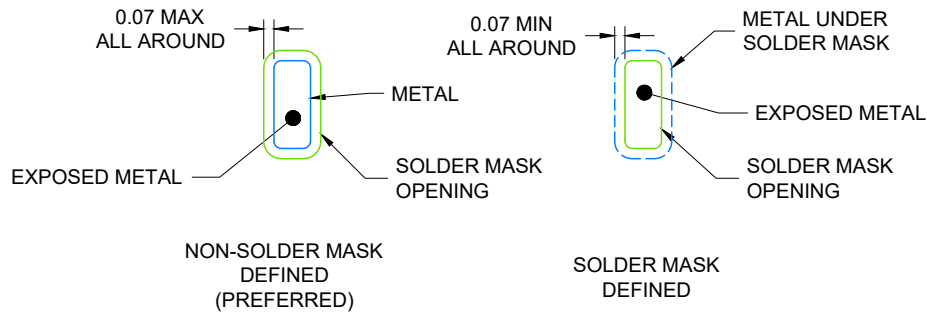

4224636/A 11/2018

NOTES: (continued)

4. This package is designed to be soldered to a thermal pad on the board. For more information, see Texas Instruments literature number SLUA271 ([www.ti.com/lit/slua271](http://www.ti.com/lit/slua271)).
5. Vias are optional depending on application, refer to device data sheet. If any vias are implemented, refer to their locations shown on this view. It is recommended that vias under paste be filled, plugged or tented.

# EXAMPLE STENCIL DESIGN

BQA0014A

WQFN - 0.8 mm max height

PLASTIC QUAD FLAT PACK-NO LEAD



SOLDER PASTE EXAMPLE  
BASED ON 0.125 mm THICK STENCIL

EXPOSED PAD  
88% PRINTED COVERAGE BY AREA  
SCALE: 20X

4224636/A 11/2018

NOTES: (continued)

- 6. Laser cutting apertures with trapezoidal walls and rounded corners may offer better paste release. IPC-7525 may have alternate design recommendations.

## MECHANICAL DATA

NS (R-PDSO-G\*\*)

PLASTIC SMALL-OUTLINE PACKAGE

14-PINS SHOWN

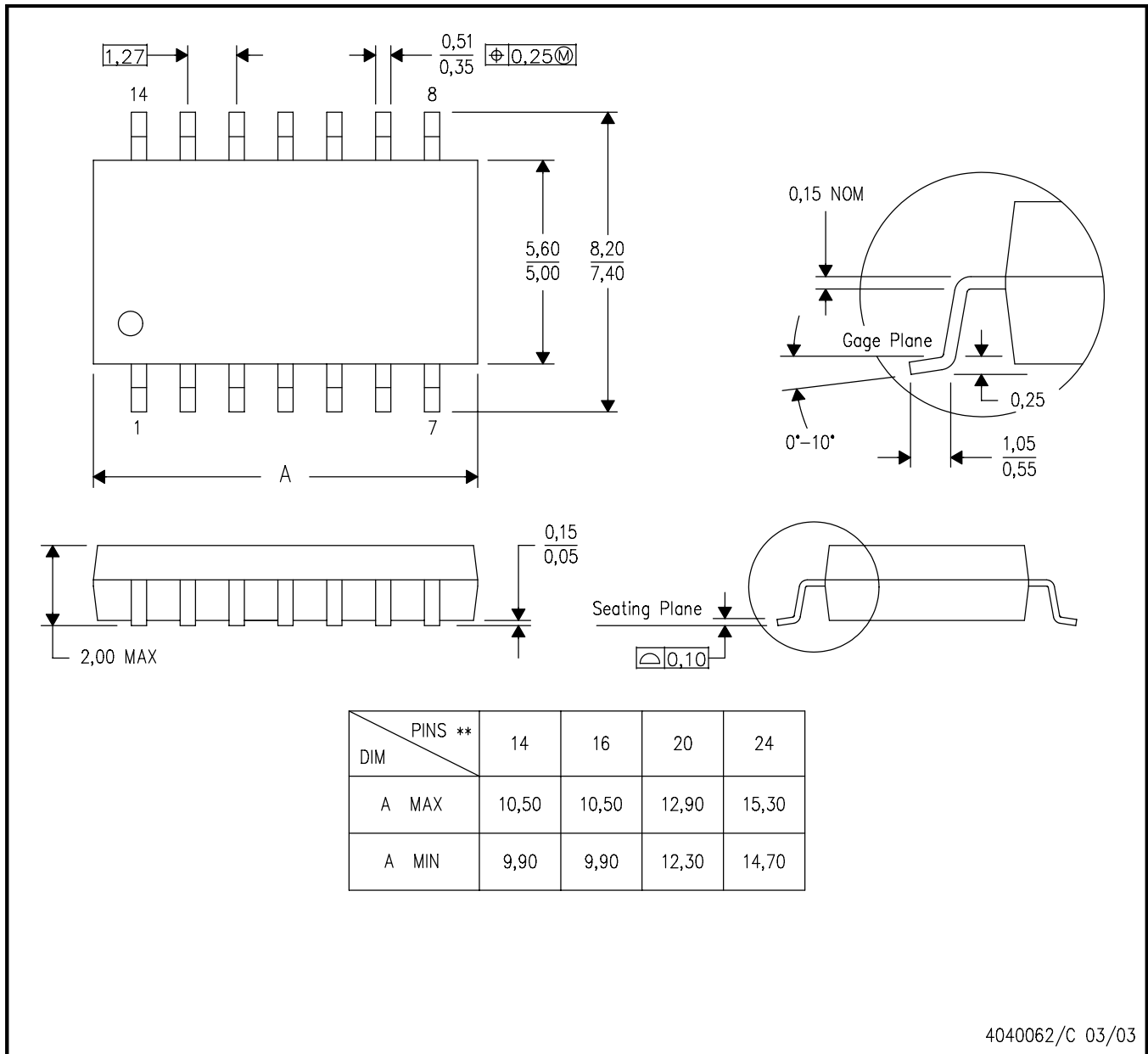

- NOTES:
- A. All linear dimensions are in millimeters.
  - B. This drawing is subject to change without notice.
  - C. Body dimensions do not include mold flash or protrusion, not to exceed 0,15.

DGV (R-PDSO-G\*\*)

PLASTIC SMALL-OUTLINE

24 PINS SHOWN



- NOTES: A. All linear dimensions are in millimeters.  
 B. This drawing is subject to change without notice.  
 C. Body dimensions do not include mold flash or protrusion, not to exceed 0,15 per side.  
 D. Falls within JEDEC: 24/48 Pins – MO-153  
 14/16/20/56 Pins – MO-194

# DB0014A



# PACKAGE OUTLINE

## SSOP - 2 mm max height

SMALL OUTLINE PACKAGE

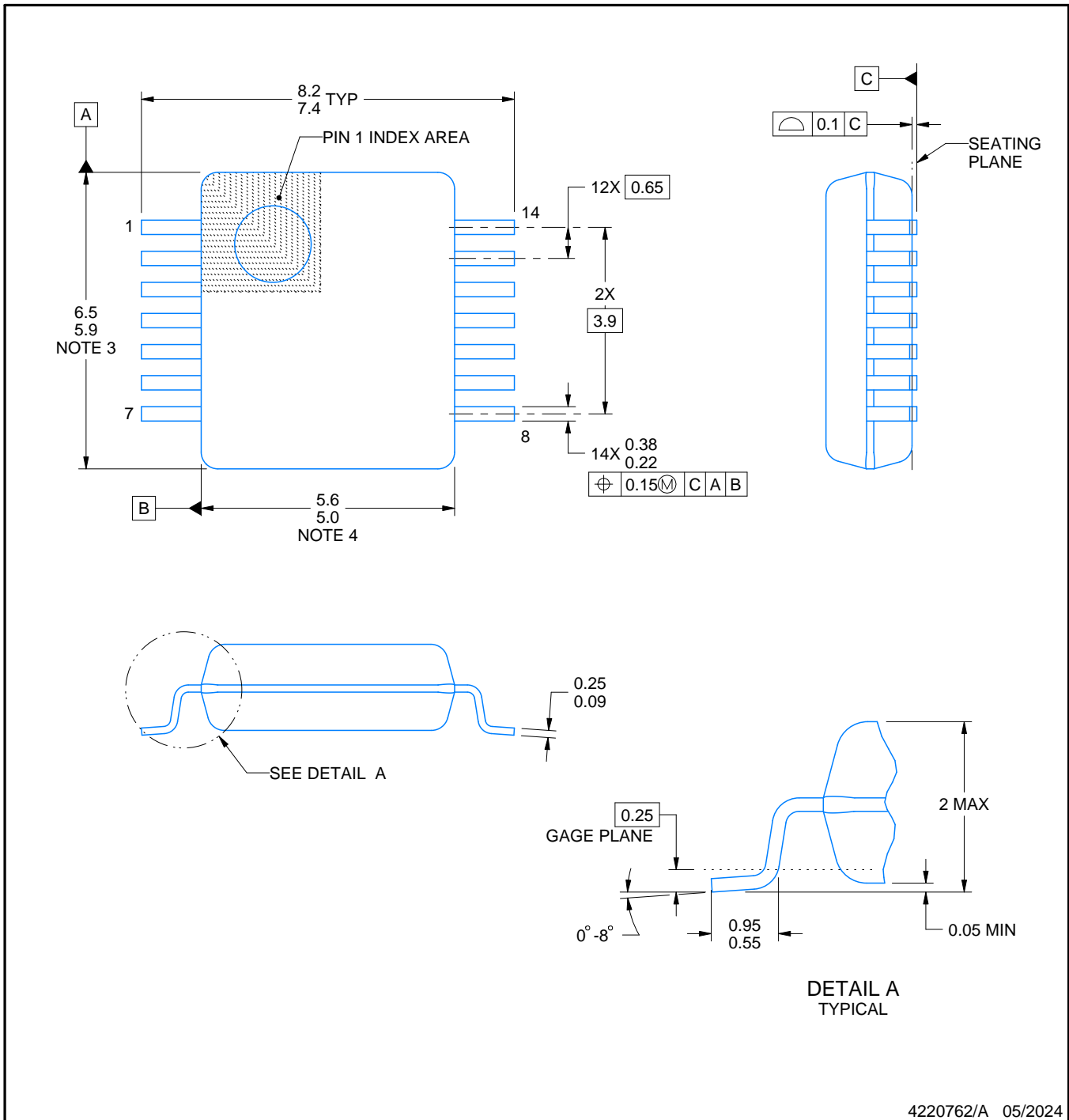

**NOTES:**

1. All linear dimensions are in millimeters. Any dimensions in parenthesis are for reference only. Dimensioning and tolerancing per ASME Y14.5M.
2. This drawing is subject to change without notice.
3. This dimension does not include mold flash, protrusions, or gate burrs. Mold flash, protrusions, or gate burrs shall not exceed 0.15 mm per side.
4. Reference JEDEC registration MO-150.

# EXAMPLE BOARD LAYOUT

DB0014A

SSOP - 2 mm max height

SMALL OUTLINE PACKAGE

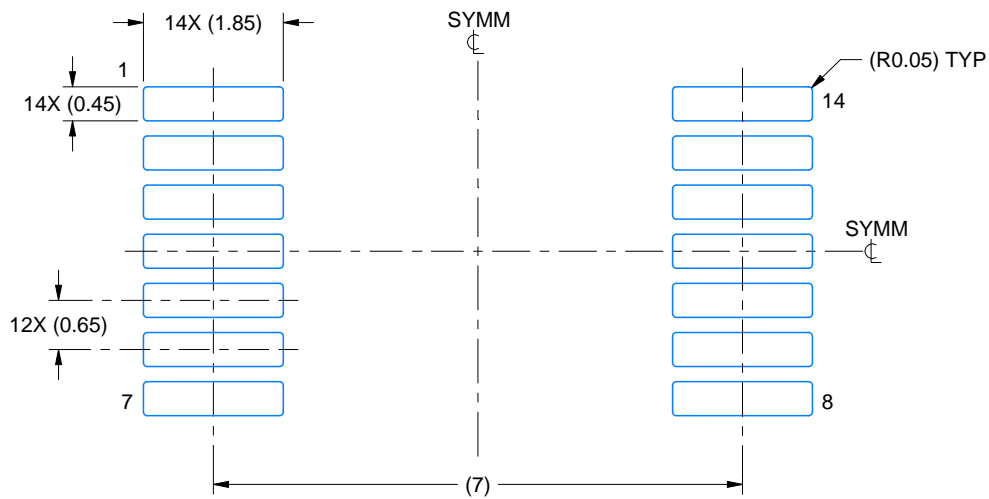

LAND PATTERN EXAMPLE  
EXPOSED METAL SHOWN  
SCALE: 10X

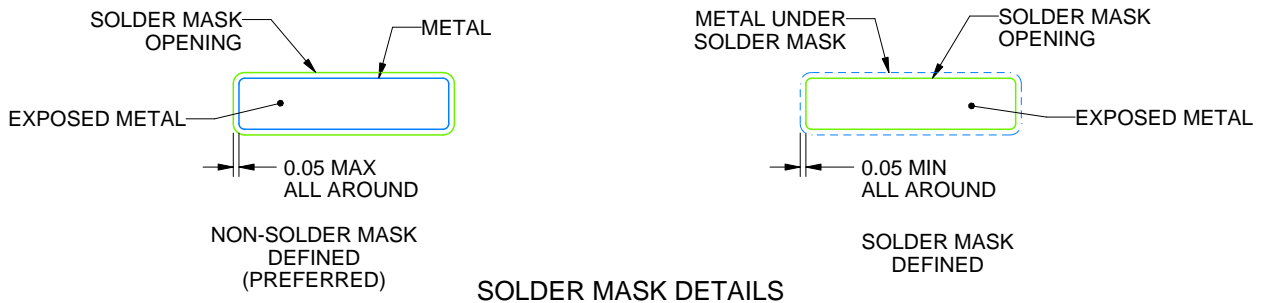

4220762/A 05/2024

NOTES: (continued)

- 5. Publication IPC-7351 may have alternate designs.
- 6. Solder mask tolerances between and around signal pads can vary based on board fabrication site.

# EXAMPLE STENCIL DESIGN

DB0014A

SSOP - 2 mm max height

SMALL OUTLINE PACKAGE

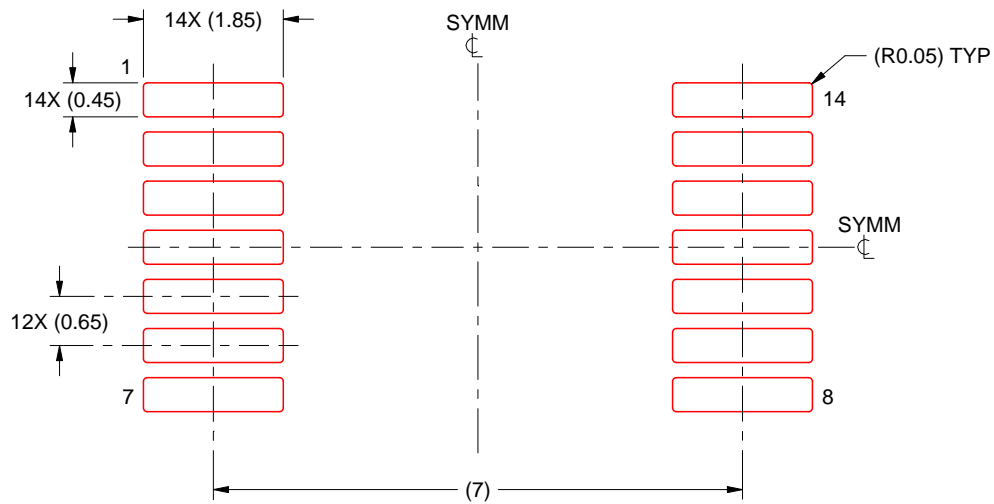

SOLDER PASTE EXAMPLE  
BASED ON 0.125 mm THICK STENCIL  
SCALE: 10X

4220762/A 05/2024

NOTES: (continued)

7. Laser cutting apertures with trapezoidal walls and rounded corners may offer better paste release. IPC-7525 may have alternate design recommendations.
8. Board assembly site may have different recommendations for stencil design.

## GENERIC PACKAGE VIEW

**FK 20**

**LCCC - 2.03 mm max height**

8.89 x 8.89, 1.27 mm pitch

LEADLESS CERAMIC CHIP CARRIER

This image is a representation of the package family, actual package may vary.  
Refer to the product data sheet for package details.

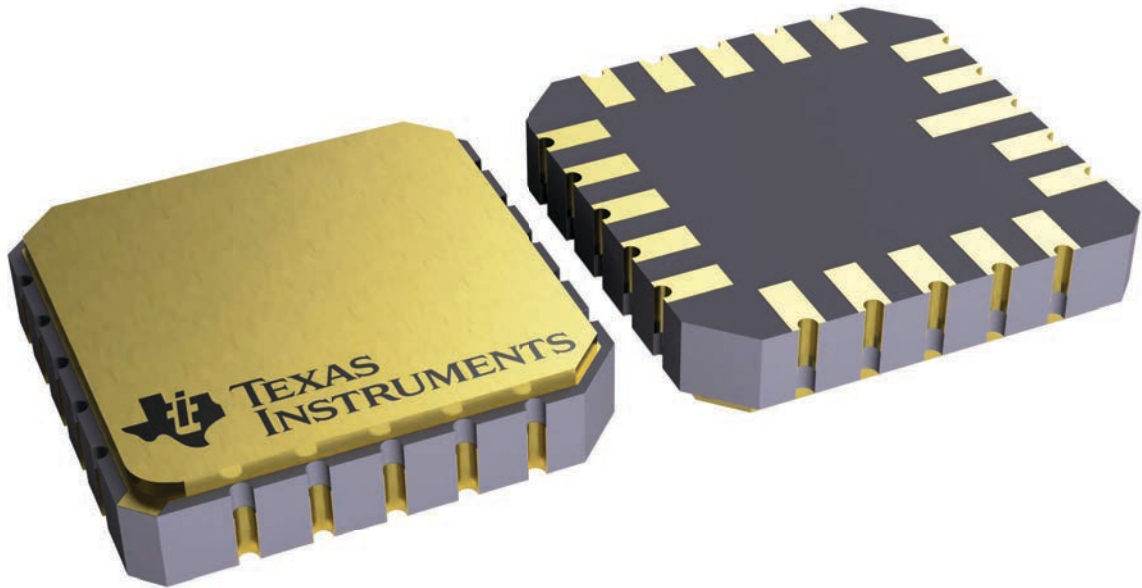

4229370VA\

N (R-PDIP-T\*\*)

PLASTIC DUAL-IN-LINE PACKAGE

16 PINS SHOWN

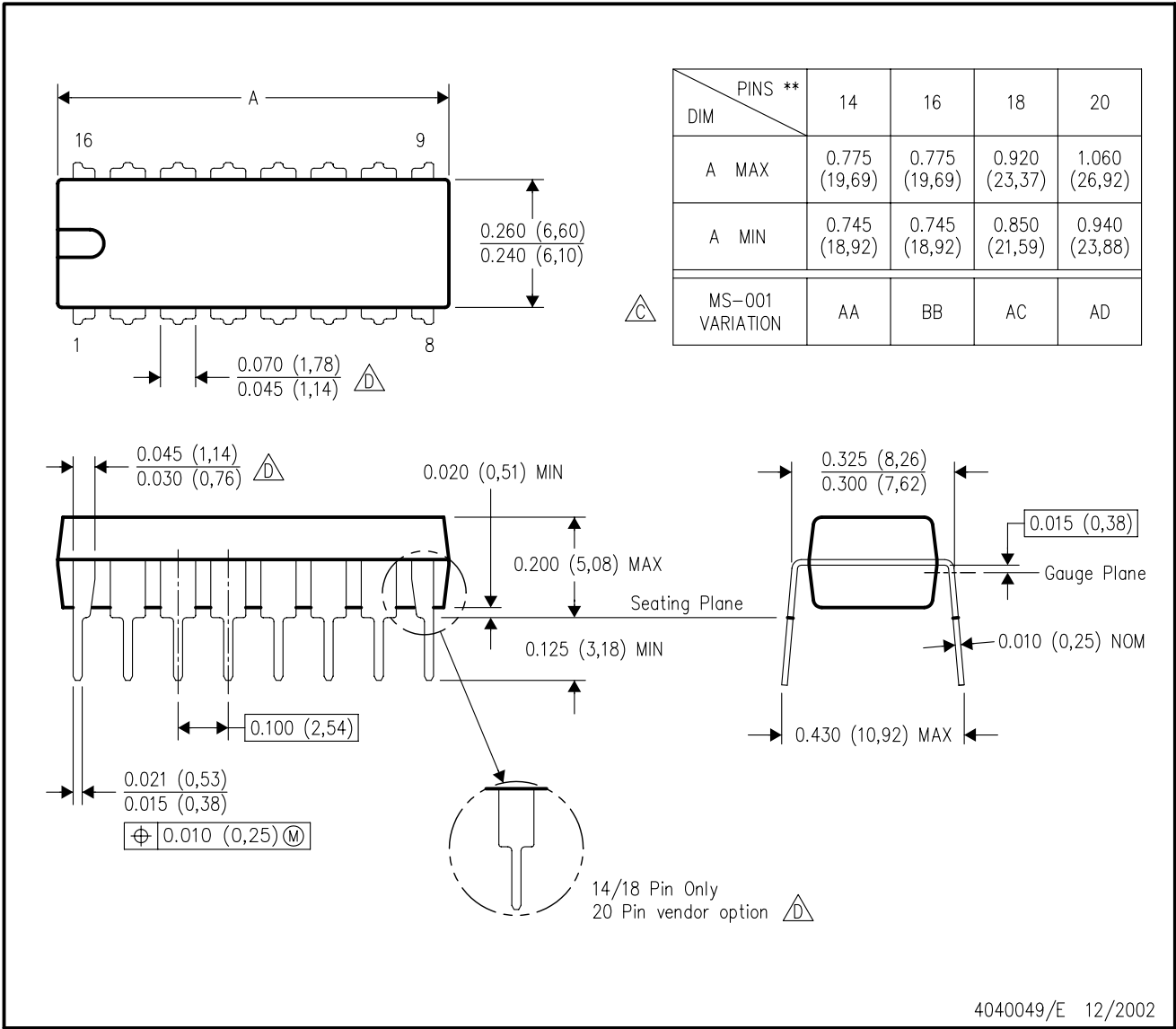

- NOTES:
- A. All linear dimensions are in inches (millimeters).
  - B. This drawing is subject to change without notice.
  - Falls within JEDEC MS-001, except 18 and 20 pin minimum body length (Dim A).
  - The 20 pin end lead shoulder width is a vendor option, either half or full width.

PW0014A



# PACKAGE OUTLINE

## TSSOP - 1.2 mm max height

SMALL OUTLINE PACKAGE



4220202/B 12/2023

NOTES:

1. All linear dimensions are in millimeters. Any dimensions in parenthesis are for reference only. Dimensioning and tolerancing per ASME Y14.5M.
2. This drawing is subject to change without notice.
3. This dimension does not include mold flash, protrusions, or gate burrs. Mold flash, protrusions, or gate burrs shall not exceed 0.15 mm per side.
4. This dimension does not include interlead flash. Interlead flash shall not exceed 0.25 mm per side.
5. Reference JEDEC registration MO-153.

# EXAMPLE BOARD LAYOUT

PW0014A

TSSOP - 1.2 mm max height

SMALL OUTLINE PACKAGE

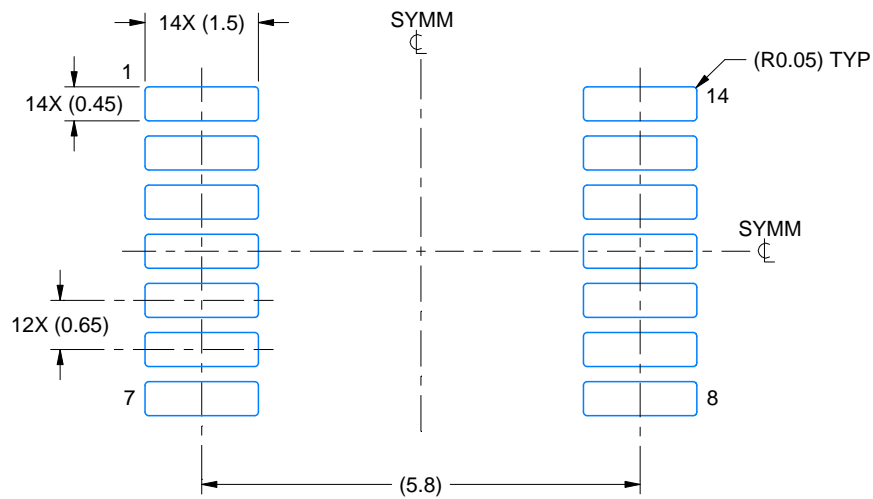

LAND PATTERN EXAMPLE  
EXPOSED METAL SHOWN  
SCALE: 10X



4220202/B 12/2023

NOTES: (continued)

- 6. Publication IPC-7351 may have alternate designs.
- 7. Solder mask tolerances between and around signal pads can vary based on board fabrication site.

# EXAMPLE STENCIL DESIGN

PW0014A

TSSOP - 1.2 mm max height

SMALL OUTLINE PACKAGE

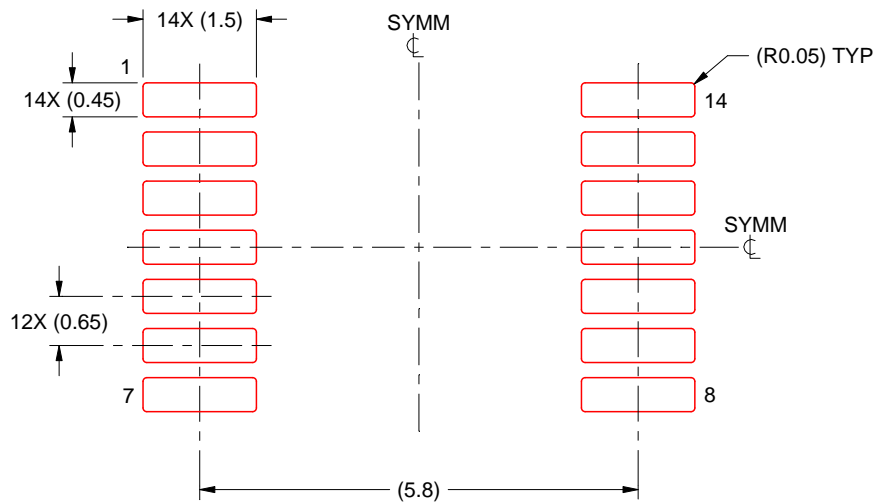

SOLDER PASTE EXAMPLE  
BASED ON 0.125 mm THICK STENCIL  
SCALE: 10X

4220202/B 12/2023

NOTES: (continued)

8. Laser cutting apertures with trapezoidal walls and rounded corners may offer better paste release. IPC-7525 may have alternate design recommendations.
9. Board assembly site may have different recommendations for stencil design.

## 重要通知和免责声明

TI“按原样”提供技术和可靠性数据（包括数据表）、设计资源（包括参考设计）、应用或其他设计建议、网络工具、安全信息和其他资源，不保证没有瑕疵且不做任何明示或暗示的担保，包括但不限于对适销性、与某特定用途的适用性或不侵犯任何第三方知识产权的暗示担保。

这些资源可供使用 TI 产品进行设计的熟练开发人员使用。您将自行承担以下全部责任：(1) 针对您的应用选择合适的 TI 产品，(2) 设计、验证并测试您的应用，(3) 确保您的应用满足相应标准以及任何其他安全、安保法规或其他要求。

这些资源如有变更，恕不另行通知。TI 授权您仅可将这些资源用于研发本资源所述的 TI 产品的相关应用。严禁以其他方式对这些资源进行复制或展示。您无权使用任何其他 TI 知识产权或任何第三方知识产权。对于因您对这些资源的使用而对 TI 及其代表造成的任何索赔、损害、成本、损失和债务，您将全额赔偿，TI 对此概不负责。

TI 提供的产品受 [TI 销售条款](#)、[TI 通用质量指南](#) 或 [ti.com](#) 上其他适用条款或 TI 产品随附的其他适用条款的约束。TI 提供这些资源并不会扩展或以其他方式更改 TI 针对 TI 产品发布的适用的担保或担保免责声明。除非德州仪器 (TI) 明确将某产品指定为定制产品或客户特定产品，否则其产品均为按确定价格收入目录的标准通用器件。

TI 反对并拒绝您可能提出的任何其他或不同的条款。

版权所有 © 2026，德州仪器 (TI) 公司

最后更新日期：2025 年 10 月